



CITY OF PROVIDENCE
Jorge O. Elorza, Mayor

Joseph Williams Park Playground Improvements

Addenda # 1

October 02, 2020

(4 Pages)

Acknowledge Addenda on Bid Form

**** BID DATE REMAINS On October 13, 2020****

Attachments:

1. Pre-bid sign in sheet (1 page)
2. Pre-bid meeting minutes (1 page)
3. Sheet L-5 (1 page)

Questions/Clarifications:

1. Can you please clarify what material should be used for pavement markings?

Pavement markings are to be solvent-borne paint.

2. Please clarify dimensions of entry signage.

The sign panel shall be 24"x18".

3. Are the footings for the GIANT play structure the same as other Kompan equipment?

The GIANT line uses the same footing types as the PCM (Moments) line.

PROVIDENCE PARKS DEPARTMENT

1000 Elmwood Avenue, Providence, Rhode Island 02907

Phone: 401-785-9450 | Fax: 401-941-5920

www.providenceri.gov

Sign-In Sheet
Pre-Bid Meeting

Tuesday – September 29, 2020 at 11:00 AM – Site

Project: Joe Williams Park Improvements

<u>Name</u>	<u>Company</u>	<u>E-Mail</u>	<u>Phone</u>
MATT JESUS	CARDT CORPORATION	MJESUS@CARDT.COM	401-739-8300
Peter Benjamin	Robit Designs	RobitUSA@Yahoo.com	1-781-837-8738
MIKE HEDLEY	B B INC	JHEDLEY127@Gmail.com	781-7750
Tom Trakas	WARR. IMP. Co.	Jtrakas@nicori.com	331-7420
NATE GAGNON	WARD WORKS INC	Wwardworks.chris@qgwil.com	401-243-5168



CITY OF PROVIDENCE
Jorge O. Elorza, Mayor

Pre-Bid Meeting – Non-Mandatory

Date: Tuesday, September 29, 2020 @ 11:00 AM (999 Elmwood Avenue, Providence RI, 02907– Site)

Project: Joseph Williams Park Improvements

Bid Due: October 13, 2020: by 2:15 PM – Board of Contract Meeting

Agenda:

1. Bid Documents, Plans & Specifications
2. Funding – **CIP**
3. MBE/WBE Utilization – 10% MBE / 10% WBE - If Sub-Contracts are to be utilized - Forms Must be Completed and Signed by MBE/WBE Coordinator for Providence. If no sub-contractors are being used – no forms are required.
4. Retainage of 5% will be held from Pay Requests until project completion
5. Insurance Certificates – Shall Include the Project Name and shall list the City of Providence as ‘Additionally Insured on a primary but non-contributing basis for General Liability Insurance per Written Contract or Agreement’ (Not Needed with Bid – After Award – GC and Sub-Contractors)
6. Performance / Payment Bond – **Required**
7. Permits – Contractor’s Responsibility to Seek Out if Permit is Needed
8. Prevailing Wage Requirements – Certified Payroll Submitted with Pay Requests – Wage Decision included in RFP
9. Sub-Contractor Utilization Form needs to be submitted with Pay Requests (If Applicable)
10. Submittals – Need Written Approval prior to purchase of Materials
11. Schedule of Values / Sequence of Work – Submitted prior to mobilization
12. Questions Need to be Submitted in Writing (5) Working Days Prior to the Opening – Sent Via E-mail to Brian Byrnes at bbyrnes@providenceri.gov and Patti Jordan at pjordan@providenceri.gov

Parks Department Contact Information

Brian Byrnes 401-660-9308 Deputy Superintendent (Primary Contact)
E-Mail: bbyrnes@providenceri.gov

PROVIDENCE PARKS DEPARTMENT
1000 Elmwood Avenue, Providence, Rhode Island 02907
Phone: 401-785-9450 | Fax: 401-941-5920
www.providenceri.gov

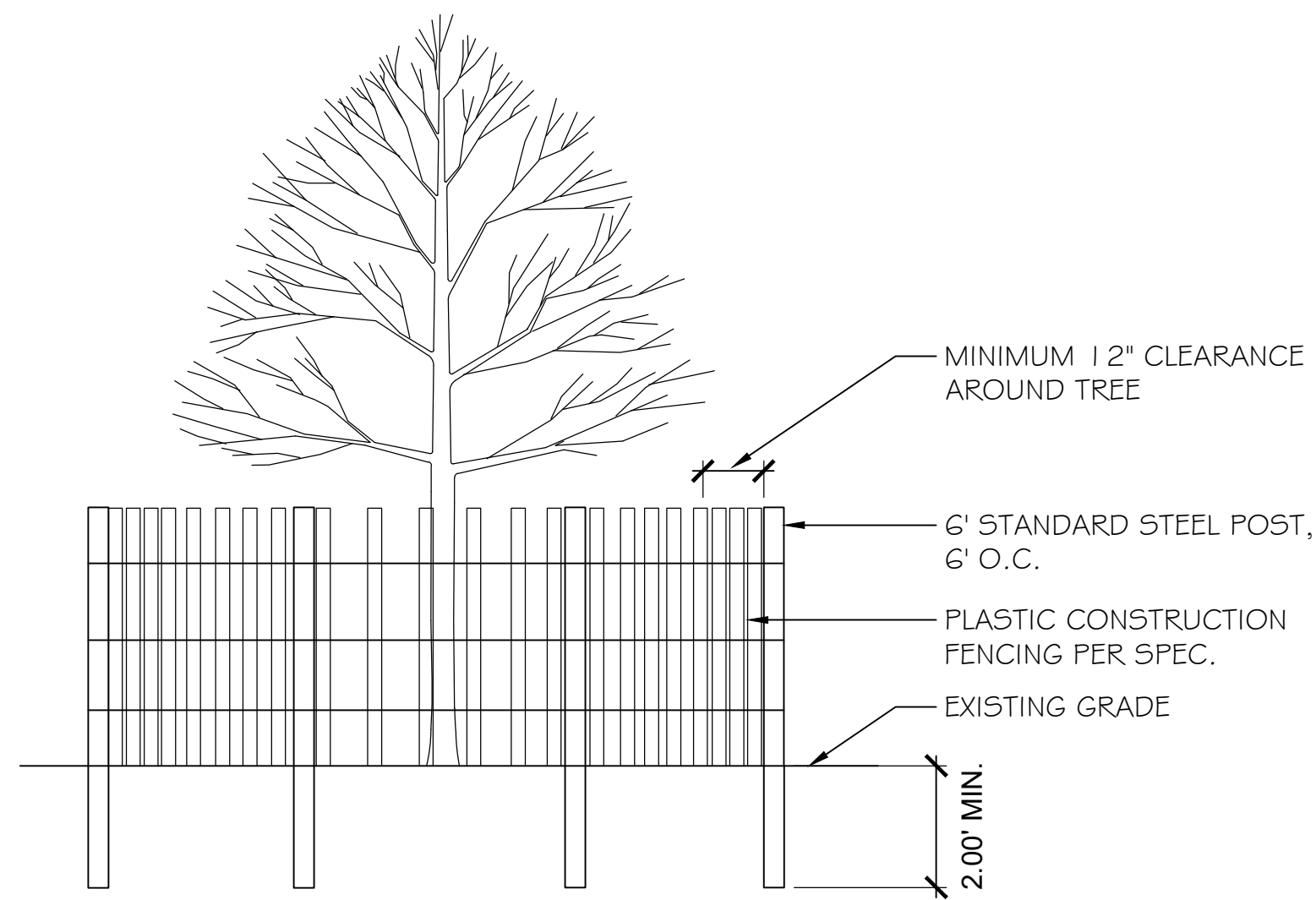

1 TREE PROTECTION
L-5 3/8" = 1'-0"

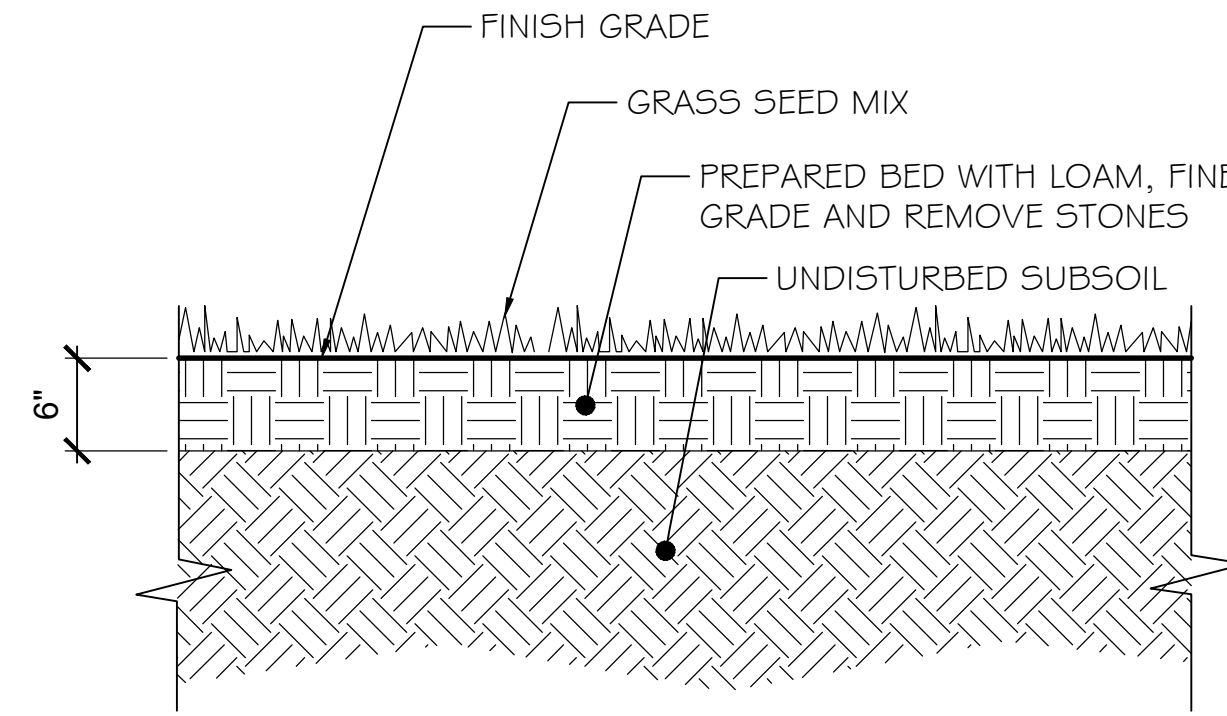

2 LOAM AND SEED
L-5 NOT TO SCALE

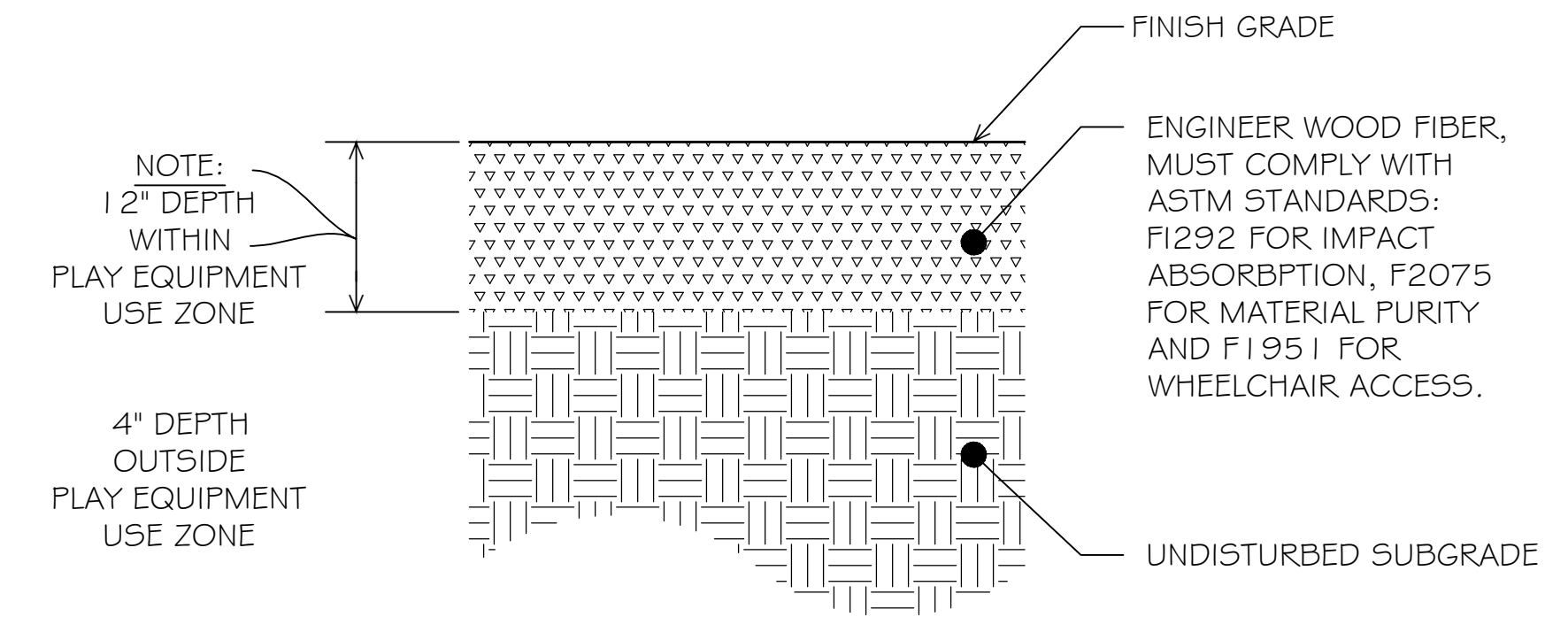

3 ENGINEERED WOOD FIBER MULCH
L-5 NOT TO SCALE

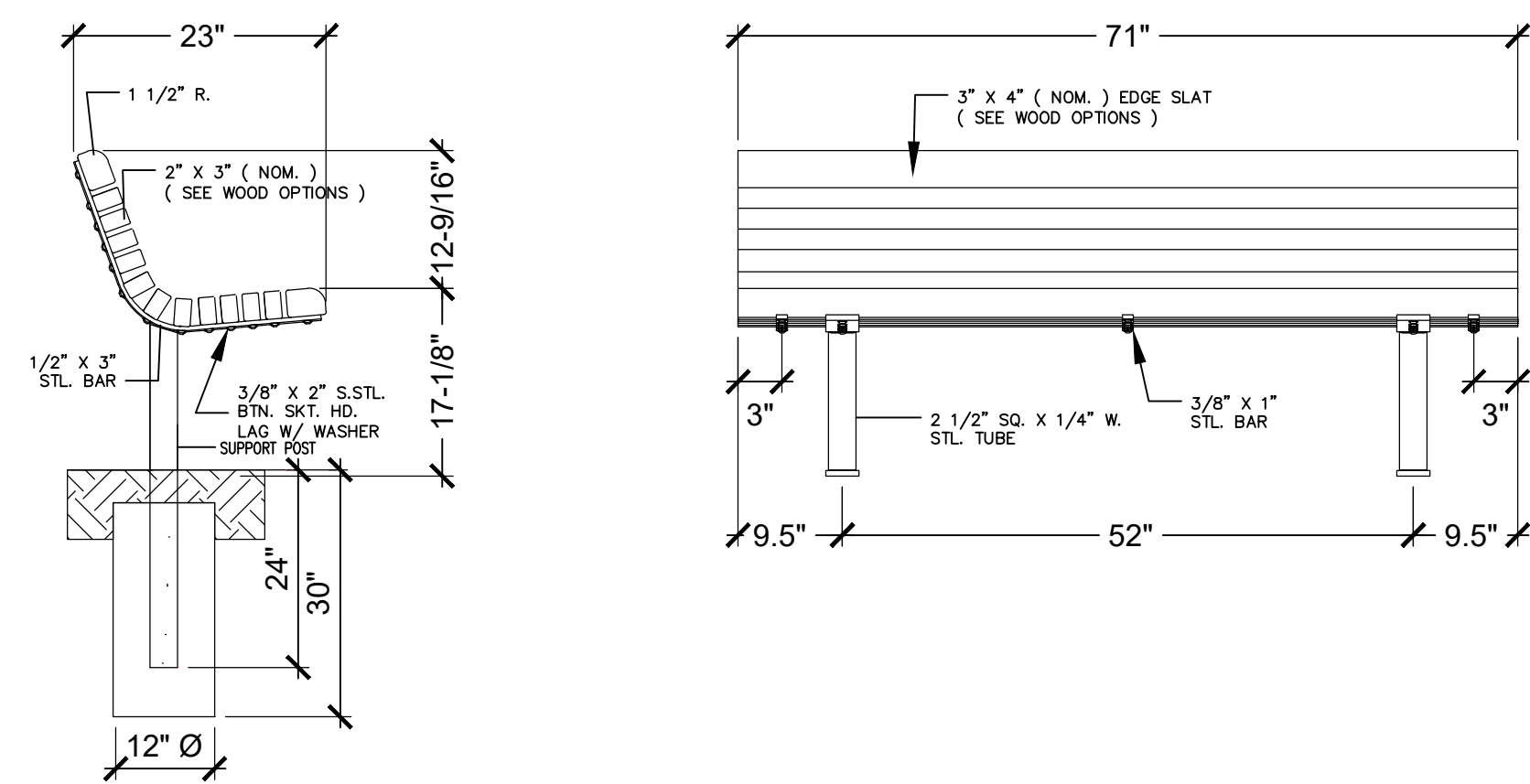

4 INGROUND MOUNT BENCH
L-5 1" = 1'-0"

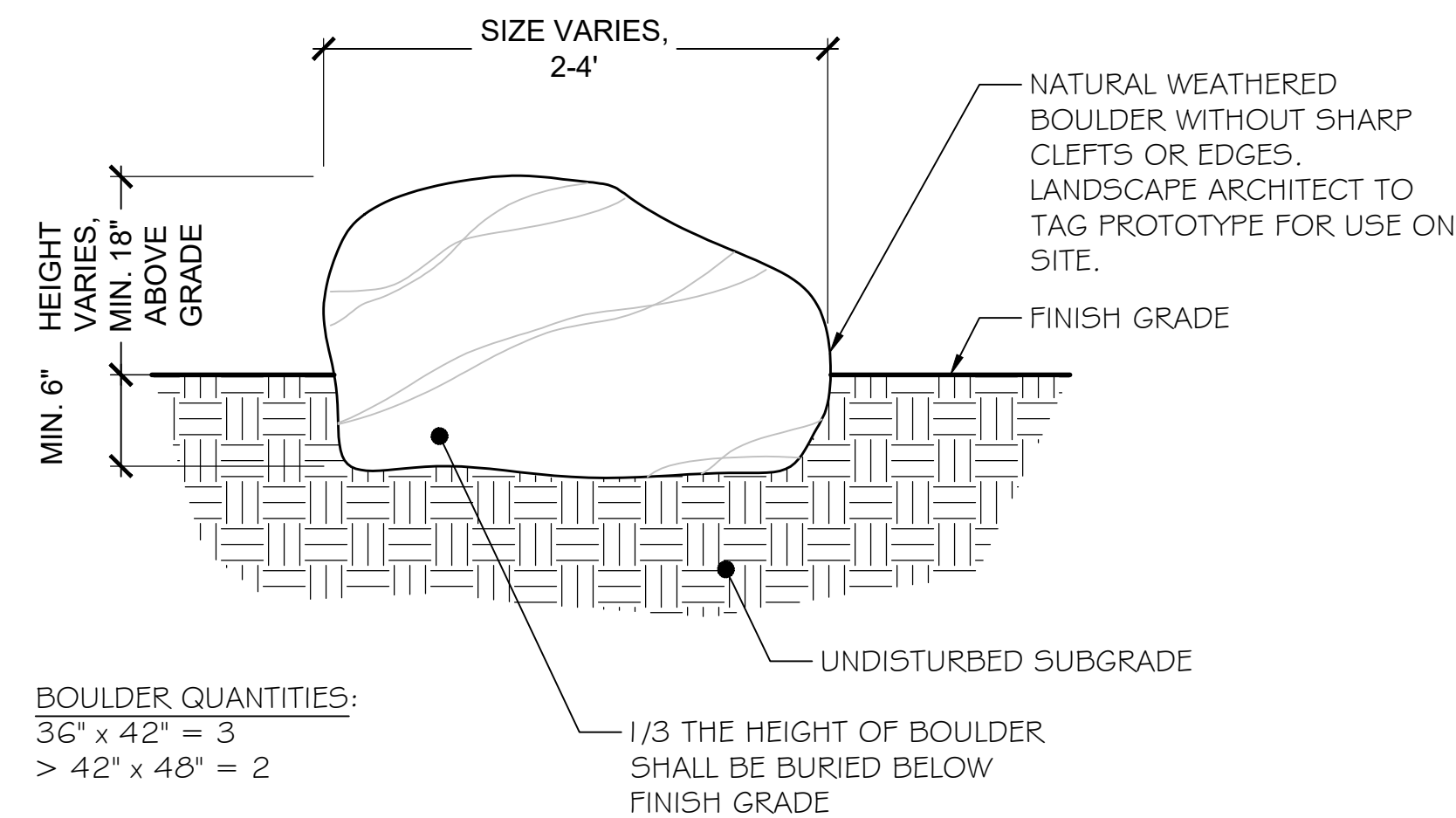

5 LANDSCAPE BOULDER
L-5 NOT TO SCALE

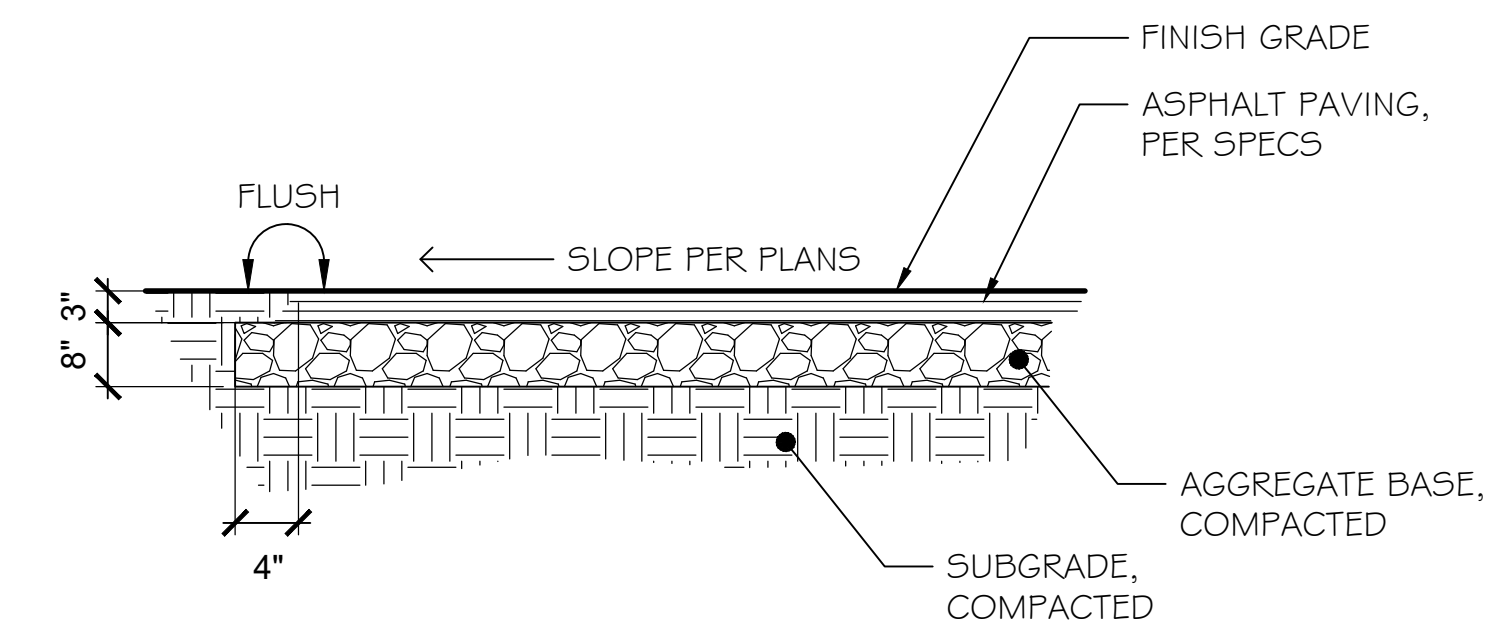

6 BITUMINOUS CONCRETE WALKWAY
L-5 NOT TO SCALE

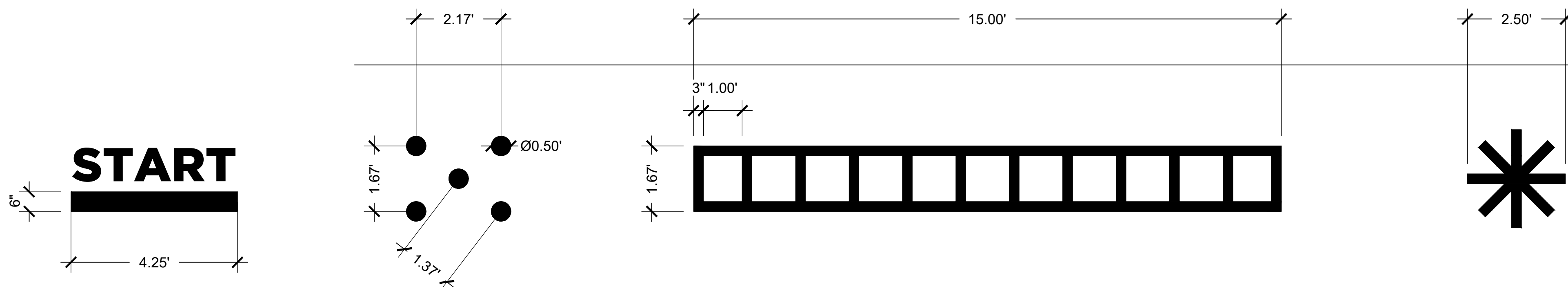

NOTE:
1. WHITE PAVEMENT MARKING PAINT, SOLVENT-BORNE
2. AGILITY LADDER AND STAR MARKINGS TO BE 3\"/>

7 PAVEMENT MARKINGS
L-5 NOT TO SCALE

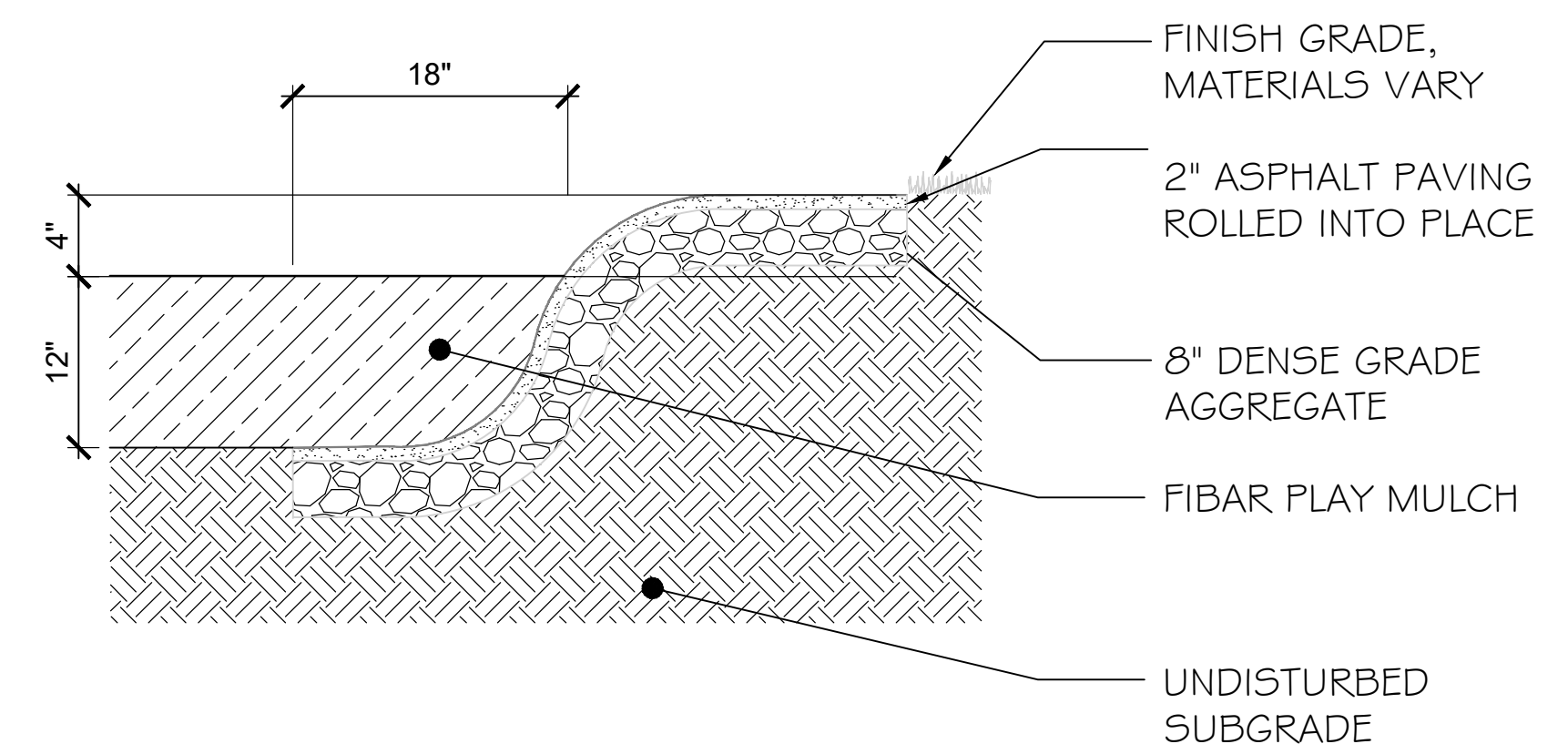

8 BITUMINOUS CONCRETE ROLL DOWN EDGE
L-5 NOT TO SCALE

COPYRIGHT (C) CITY OF PROVIDENCE PARKS DEPARTMENT, ALL RIGHTS RESERVED 2020.
NO PART OF THIS DOCUMENT MAY BE REPRODUCED, STORED IN A RETRIEVAL SYSTEM OR TRANSMITTED IN ANY FORM OR BY ANY MEANS, ELECTRONIC, MECHANICAL, PHOTOCOPYING, RECORDING OR OTHERWISE WITHOUT THE PRIOR WRITTEN PERMISSION OF THE CITY OF PROVIDENCE PARKS DEPARTMENT. ANY MODIFICATIONS TO THIS DOCUMENT WITHOUT THE WRITTEN PERMISSION OF THE CITY OF PROVIDENCE PARKS DEPARTMENT SHALL RENDER IT INVALID AND UNUSABLE.

NO.	REVISION	DATE
1	ADDENDUM #1	10/01/20

DATE:	09/14/20
SCALE:	AS SHOWN
DRAWN BY:	SHEET NO.
LL	L-5
CHECKED/ APPROVED:	OF 06
MG	