



**BOARD OF CONTRACT AND SUPPLY
CITY OF PROVIDENCE, RHODE ISLAND**

REQUEST FOR PROPOSALS

Item Description: COLLYER PARK IMPROVEMENTS

Date to be opened: NOVEMBER 8, 2021

Issuing Department: PARKS DEPARTMENT

QUESTIONS

- Please direct questions relative to the bidding process, how to fill out forms, and how to submit a bid (Pages 1-8) to Purchasing Agent Patti Jordan.
 - Phone: (401) 680-5264
 - Email: pjordan@providenceri.gov
 - Please use the subject line “**RFP Question**”
- Please direct questions relative to the Minority and Women’s Business Enterprise Program and the corresponding forms (Pages 9-13) to the MBE/WBE Outreach Director for the City of Providence, Grace Diaz
 - Phone: (401) 680-5766
 - Email: gdiaz@providenceri.gov
 - Please use subject line “**MBE WBE Forms**”
- Please direct questions relative to the specifications outlined (beginning on page 14) to the issuing department’s subject matter expert:
 - **Sam Greenwood**
 - **401-680-7299**
 - **sgreenwood@providenceri.Gov**

Pre-bid Conference (NON-MANDATORY)

October 25, 2021 at 10 AM

Meeting on-site at 35 Collyer St Providence, RI



**BOARD OF CONTRACT AND SUPPLY
CITY OF PROVIDENCE, RHODE ISLAND**

INSTRUCTIONS FOR SUBMISSION

Bids may be submitted up to **2:15 P.M.** on the above meeting date at the **Department of the City Clerk, Room 311, City Hall, 25 Dorrance Street, Providence.** At 2:15 P.M. all bids will be publicly opened and read at the Board of Contract Meeting in the City Council Chambers, on the 3rd floor of City Hall.

- Bidders must submit **2 copies** of their bid in sealed envelopes or packages labeled with the captioned **Item Description** and the **City Department to which the RFP and bid are related.** (On page 1)
- Communications to the Board of Contract and Supply that are not competitive sealed bids (i.e. product information/samples) should have “**NOT A BID**” written on the envelope or wrapper.
- Only use form versions and templates included in this RFP. If you have an old version of a form do not recycle it for use in this bid.
- The bid envelope and information relative to the bid must be addressed to:

**Board of Contract and Supply
Department of the City Clerk – City Hall, Room 311
25 Dorrance Street
Providence, RI 02903**

****PLEASE NOTE:** This bid may include details regarding information that you will need to provide (such as proof of licenses) to the issuing department before the formalization of an award.

This information is NOT requested to be provided in your initial bid by design.

All bids submitted to the City Clerk become public record. Failure to follow instructions could result in information considered private being posted to the city’s Open Meetings Portal and made available as a public record. The City has made a conscious effort to avoid the posting of sensitive information on the City’s Open Meetings Portal, by requesting that such sensitive information be submitted to the issuing department only at their request.



**BOARD OF CONTRACT AND SUPPLY
CITY OF PROVIDENCE, RHODE ISLAND**

BID PACKAGE CHECKLIST

Digital forms are available in the City of Providence Purchasing Department Office or online at <http://www.providenceri.gov/purchasing/how-to-submit-a-bid/>

The bid package **MUST** include the following, in this order:

- Bid Form 1: Bidder's Blank as the cover page/ 1st page (*see page 6 of this document*)
- Bid Form 2: Certification of Bidder as 2nd page (*see page 7 of this document*)
- Bid Form 3: Certificate Regarding Public Records (*see page 8 of this document*)
- Forms from the Minority and Women Business Enterprise Program: Based on Bidder Category. *See forms and instructions enclosed (pages 9-13) or on: <https://www.providenceri.gov/purchasing/minority-women-owned-business-mbewbe-procurement-program/>*

***Please note: MBE/WBE forms must be completed for EVERY bid submitted and must be inclusive of ALL required signatures. Forms without all required signatures will be considered incomplete.**

- Bidder's Proposal/Packet: Formal response to the specifications outlined in this RFP, including pricing information and details related to the good(s) or service(s) being provided. Please be mindful of formatting responses as requested to ensure clarity.
- Financial Assurance, *if requested* (as indicated on page 5 of this document under "Bid Terms")

All of the above listed documents are REQUIRED. (With the exception of financial assurances, which are only required if specified on page 5.)

*****Failure to meet specified deadlines, follow specific submission instructions, or enclose all required documents with all applicable signatures will result in disqualification, or in an inability to appropriately evaluate bids.**



BOARD OF CONTRACT AND SUPPLY
CITY OF PROVIDENCE, RHODE ISLAND

NOTICE TO VENDORS

1. The Board of Contract and Supply will make the award to the lowest qualified and responsible bidder.
2. In determining the lowest responsible bidder, cash discounts based on preferable payment terms will not be considered.
3. Where prices are the same, the Board of Contract and Supply reserves the right to award to one bidder, or to split the award.
4. No proposal will be accepted if the bid is made in collusion with any other bidder.
5. Bids may be submitted on an “equal in quality” basis. The City reserves the right to decide equality. Bidders must indicate brand or the make being offered and submit detailed specifications if other than brand requested.
6. A bidder who is an out-of-state corporation shall qualify or register to transact business in this State, in accordance with the Rhode Island Business Corporation Act, RIGL Sec. 7-1.2-1401, et seq.
7. The Board of Contract and Supply reserves the right to reject any and all bids.
8. Competing bids may be viewed in person at the Department of the City Clerk, City Hall, Providence, immediately upon the conclusion of the formal Board of Contract and Supply meeting during which the bids were unsealed/opened. Bids may also be accessed electronically on the internet via the City’s [Open Meetings Portal](#).
9. As the City of Providence is exempt from the payment of Federal Excise Taxes and Rhode Island Sales Tax, prices quoted are not to include these taxes.
10. In case of error in the extension of prices quoted, the unit price will govern.
11. The contractor will **NOT** be permitted to: a) assign or underlet the contract, or b) assign either legally or equitably any monies or any claim thereto without the previous written consent of the City Purchasing Director.
12. Delivery dates must be shown in the bid. If no delivery date is specified, it will be assumed that an immediate delivery from stock will be made.
13. A certificate of insurance will normally be required of a successful vendor.
14. For many contracts involving construction, alteration and/or repair work, State law provisions concerning payment of prevailing wage rates apply ([RIGL Sec. 37-13-1 et seq.](#))
15. No goods should be delivered or work started without a Purchase Order.
16. **Submit 2 copies of the bid to the City Clerk, unless the specification section of this document indicates otherwise.**
17. Bidder must certify that it does not unlawfully discriminate on the basis of race, color, national origin, gender, gender identity or expression, sexual orientation and/or religion in its business and hiring practices and that all of its employees are lawfully employed under all applicable federal, state and local laws, rules and regulations. (See Bid Form 2.)



BOARD OF CONTRACT AND SUPPLY
CITY OF PROVIDENCE, RHODE ISLAND

BID TERMS

1. Financial assurances may be required in order to be a successful bidder for Commodity or Construction and Service contracts. If either of the first two checkboxes below is checked, the specified assurance must accompany a bid, or the bid will not be considered by the Board of Contract and Supply. The third checkbox indicates the lowest responsible bidder will be contacted and required to post a bond to be awarded the contract.
 - a) A certified check for \$_____ must be deposited with the City Clerk as a guarantee that the Contract will be signed and delivered by the bidder.
 - b) A bid bond in the amount of 5 per centum (%) of the proposed total price, must be deposited with the City Clerk as a guarantee that the contract will be signed and delivered by the bidder; and the amount of such bid bond shall be retained for the use of the City as liquidated damages in case of default.
 - c) A performance and payment bond with a satisfactory surety company will be posted by the bidder in a sum equal to one hundred per centum (100%) of the awarded contract.
 - d) No financial assurance is necessary for this item.
2. Awards will be made within **sixty (60) days of bid opening**. All bid prices will be considered firm, unless qualified otherwise. Requests for price increases will not be honored.
3. Failure to deliver within the time quoted or failure to meet specifications may result in default in accordance with the general specifications. It is agreed that deliveries and/or completion are subject to strikes, lockouts, accidents and Acts of God.

The following entry applies only for COMMODITY BID TERMS:

4. Payment for partial delivery will not be allowed except when provided for in blanket or term contracts.

The following entries apply only for CONSTRUCTION AND SERVICE BID TERMS:

5. Only one shipping charge will be applied in the event of partial deliveries for blanket or term contracts.
6. Prior to commencing performance under the contract, the successful bidder shall attest to compliance with the provisions of the Rhode Island Worker's Compensation Act, RIGL 28-29-1, et seq. If exempt from compliance, the successful bidder shall submit a sworn Affidavit by a corporate officer to that effect, which shall accompany the signed contract.
7. Prior to commencing performance under the contract, the successful bidder shall, submit a certificate of insurance, in a form and in an amount satisfactory to the City.



**BOARD OF CONTRACT AND SUPPLY
CITY OF PROVIDENCE, RHODE ISLAND**

BID FORM 1: Bidders Blank

1. Bids must meet the attached specifications. Any exceptions or modifications must be noted and fully explained.
2. Bidder's responses must be in ink or typewritten, and all blanks on the bid form should be completed.
3. The price or prices proposed should be stated both in **WRITING** and in **FIGURES**, and any proposal not so stated may be rejected. **Contracts exceeding twelve months must specify annual costs for each year.**
4. Bids **SHOULD BE TOTALED** so that the final cost is clearly stated (unless submitting a unit price bid), however **each item should be priced individually**. Do not group items. Awards may be made on the basis of *total* bid or by *individual items*.
5. All bids **MUST BE SIGNED IN INK.**

Name of Bidder (Firm or Individual): _____

Contact Name: _____

Business Address: _____

Business Phone #: _____

Contact Email Address: _____

Agrees to bid on (Write the "Item Description" here): _____

If the bidder's company is based in a state *other than Rhode Island*, list name and contact information for a local agent for service of process that is *located within Rhode Island* _____

Delivery Date (if applicable): _____

Name of Surety Company (if applicable): _____

Total Amount in Writing*: _____

Total Amount in Figures*: _____

**** If you are submitting a unit price bid, please insert "Unit Price Bid"***

Use additional pages if necessary for additional bidding details.

Signature of Representation

Title



BOARD OF CONTRACT AND SUPPLY
CITY OF PROVIDENCE, RHODE ISLAND

BID FORM 2: Certification of Bidder
(Non-Discrimination/Hiring)

Upon behalf of _____ (Firm or Individual Bidding),

I, _____ (Name of Person Making Certification),

being its _____ (Title or "Self"), hereby certify that:

1. Bidder does not unlawfully discriminate on the basis of race, color, national origin, gender, sexual orientation and/or religion in its business and hiring practices.
2. All of Bidder's employees have been hired in compliance with all applicable federal, state and local laws, rules and regulations.

I affirm by signing below that I am duly authorized on behalf of Bidder, on
this _____ day of _____, 20_____.

Signature of Representation

Printed Name



BOARD OF CONTRACT AND SUPPLY
CITY OF PROVIDENCE, RHODE ISLAND

BID FORM 3: Certificate Regarding Public Records

Upon behalf of _____ (Firm or Individual Bidding),

I, _____ (Name of Person Making Certification),

being its _____ (Title or "Self"), hereby certify an

understanding that:

1. All bids submitted in response to Requests for Proposals (RFP's) and Requests for Qualification (RFQ's), documents contained within, and the details outlined on those documents become public record upon receipt by the City Clerk's office and opening at the corresponding Board of Contract and Supply (BOCS) meeting.
2. The Purchasing Department and the issuing department for this RFP/RFQ have made a conscious effort to request that sensitive/personal information be submitted directly to the issuing department and only at request if verification of specific details is critical the evaluation of a vendor's bid.
3. The requested supplemental information may be crucial to evaluating bids. Failure to provide such details may result in disqualification, or an inability to appropriately evaluate bids.
4. If sensitive information that has not been requested is enclosed or if a bidder opts to enclose the defined supplemental information prior to the issuing department's request in the bidding packet submitted to the City Clerk, the City of Providence has no obligation to redact those details and bears no liability associated with the information becoming public record.
5. The City of Providence observes a public and transparent bidding process. Information required in the bidding packet may not be submitted directly to the issuing department at the discretion of the bidder in order to protect other information, such as pricing terms, from becoming public. Bidders who make such an attempt will be disqualified.

I affirm by signing below that I am duly authorized on behalf of Bidder, on

this _____ day of _____ 20_____.

Signature of Representation

Printed Name



**BOARD OF CONTRACT AND SUPPLY
CITY OF PROVIDENCE, RHODE ISLAND**

WBE/MBE Form Instructions

The City of Providence actively seeks Minority and Women business enterprises to participate in bids to meet the City's procurement needs. Pursuant to the City of Providence Code of Ordinances, Chapter 21, Article II, Sec. 21-52 (Minority and Women's Business Enterprise) and Rhode Island General Laws (as amended), Chapter 31-14, et seq. (Minority Business Enterprise), Minority Business Enterprise (MBE) and Women's Business Enterprise (WBE) participation goals apply to contracts.

The goal for Minority Business Enterprise (MBE) participation is **10%** of the total bid value.

The goal for Women's Business Enterprise (WBE) participation is **10%** of the total bid value.

The goal for combined MBE/WBE participation is **20%** of the total bid value.

Only businesses certified with the State of Rhode Island as minority and/or women business enterprises are counted towards the City's goals. Eligible minority or women-owned businesses are encouraged to seek certification from the State of Rhode Island Minority Business Enterprise Compliance Office at: <http://odeo.ri.gov/offices/mbeco/>

Note: MBE certification with the State of Rhode Island on the basis of Portuguese heritage is not currently recognized by the City of Providence's MBE program.

Bid Requirements:

All Bidders: All bidders must complete and submit the **MBE/WBE Participation Affidavit** indicating whether or not they are a state-certified MBE/WBE and acknowledging the City's participation goals. Submission of this form is required with **every bid**. Your bid will not be accepted without an affidavit.

Bidders who will be subcontracting: Bidders who will be subcontracting must submit the **Subcontractor Disclosure Form** as part of their bid submission. All subcontractors, regardless of MBE/WBE status, must be listed on this form. Business NAICS codes can be found at <https://www.naics.com/search/>. Awarded bidders are required to submit **Subcontractor Utilization and Payment Reports** with each invoice.

Waiver Requests:

If the percentage of the total amount of the bid being awarded to MBE or WBE vendors is less than 20% (Box F on the Subcontractor Disclosure Form) and the prime contractor is not a Rhode Island State-certified MBE or WBE, the Bidder must complete the **MBE/WBE Waiver Request Form** for review. Waivers will be considered on a case by case basis.

No waiver will be granted unless the waiver request includes documentation that demonstrates that the Bidder has made good faith efforts to achieve the City's stated participation goals. Waivers must be reviewed and signed by the City of Providence's MBE/WBE Outreach Director, Grace Diaz, or her designee. Department Directors cannot recommend a bidder for award if this form is applicable and absent. If the bid does not meet the participation goals of the City of Providence and a waiver is not filed with the signature of the MBE/WBE Outreach Director or her designee, the bid will not be accepted.

Verifying MBE/WBE Certification

It is the responsibility of the bidder to confirm that every MBE/WBE named in a proposal and included in a contract is certified by the Rhode Island Minority Business Enterprise Compliance office. The current MBE/WBE directory is available at the State of RI MBE Office, One Capitol Hill, 2nd Floor, Providence, RI, or online at <http://odeo.ri.gov/offices/mbeco/mbe-wbe.php>. You can also call (401) 574-8670 to verify certification, expiration dates, and services that the MBE/WBE is certified to provide. Note: MBE certification with the State of Rhode Island on the basis of Portuguese heritage is not currently recognized by the City of Providence's MBE program.



BOARD OF CONTRACT AND SUPPLY
CITY OF PROVIDENCE, RHODE ISLAND

Form Instructions:

Access all bid forms from <http://www.providenceri.gov/oeo/> or <http://www.providenceri.gov/purchasing/minority-women-owned-business-mbewbe-procurement-program/>. **Download** the forms as blank PDFs. Once saved on your computer, fill them out using the Adobe program. The fillable PDFs must be completed in Adobe in order to be saved properly. Google Chrome and similar platforms do not allow for the forms to be saved as filled PDFs. Therefore, please download the blank forms to your computer, then fill them out and save.

Assistance with Form Requirements

Examples of completed forms can be found on the City of Providence website at <http://www.providenceri.gov/oeo/> or <http://www.providenceri.gov/purchasing/minority-women-owned-business-mbewbe-procurement-program/>.

Contract Requirements:

Prime contractors engaging subcontractors must submit the *Subcontractor Utilization and Payment Report* to the City Department's Fiscal Agent with every invoice and with request for final payment. This form is not submitted as a part of the initial bid package.

For contracts with duration of less than 3 months, this form must be submitted along with the contractor's request for final payment. The form must include all subcontractors utilized on the contract, both MBE/WBE and non- MBE/WBE, the total amount paid to each subcontractor for the given period and to date. During the term of the contract, any unjustified failure to comply with the MBE/WBE participation requirements is a material breach of contract.

Questions?

For more information or for assistance with MBE/WBE Forms, contact the City of Providence MBE/WBE Outreach Director, Grace Diaz, at mbe-wbe@providenceri.com or (401) 680-5766.



**BOARD OF CONTRACT AND SUPPLY
CITY OF PROVIDENCE, RHODE ISLAND**

MBE/WBE PARTICIPATION AFFIDAVIT

Item Discussion (as seen on RFP):

Prime Bidder: _____

Prime Bidder (Company) Phone Number: _____

Which one of the following describes your business' status in terms of Minority and/or Woman-Owned Business Enterprise certification with the State of Rhode Island? MBE WBE Neither MBE nor WBE

By initialing the following sections and signing the bottom of this document in my capacity as the contractor or an authorized representative of contractor, I make this Affidavit:

It is the policy of the City of Providence that minority business enterprises (MBEs) and women business enterprises (WBEs) should have the maximum opportunity to participate in procurements and projects as prime contractors and vendors. Pursuant to Sec. 21-52 of the Providence Code of Ordinances and Chapter 31-14 *et seq.* of the Rhode Island General Laws (as amended), MBE and WBE participation goals apply to contracts.

The goal for Minority Business Enterprise (MBE) participation is 10% of the total bid value.
The goal for Women's Business Enterprise (WBE) participation is 10% of the total bid value.
The goal for combined MBE/WBE participation is 20% of the total bid value.

I acknowledge the City of Providence's goals of supporting MBE/WBE certified businesses. Initial _____

If awarded the contract, I understand that my company must submit to the Minority and Women's Business Coordinator at the City of Providence (MBE/WBE Office), copies of all executed agreements with the subcontractor(s) being utilized to achieve the participation goals and other requirements of the RI General Laws. **I understand that these documents must be submitted prior to the issuance of a notice to proceed.** Initial _____

I understand that, if awarded the contract, my firm must submit to the MBE/WBE Office canceled checks and reports required by the MBE/WBE Office on a quarterly basis verifying payments to the subcontractors(s) utilized on the contract.
Initial _____

If I am awarded this contract and find that I am unable to utilize the subcontractor(s) identified in my Statement of Intent, I understand that I must substitute another certified MBE and WBE firm(s) to meet the participation goals. **I understand that I may not make a substitution until I have obtained the written approval of the MBE/WBE Office.**
Initial _____

If awarded this contract, I understand that authorized representatives of the City of Providence may examine the books, records and files of my firm from time to time, to the extent that such material is relevant to a determination of whether my firm is complying with the City's MBE/WBE participation requirements.
Initial _____

I do solemnly declare and affirm under the penalty of perjury that the contents of the foregoing Affidavit are true and correct to the best of my knowledge, information and belief.

Signature of Bidder

Printed Name

Company Name

Date



**BOARD OF CONTRACT AND SUPPLY
CITY OF PROVIDENCE, RHODE ISLAND**

SUBCONTRACTOR DISCLOSURE FORM

Fill out this form only if you WILL SUBCONTRACT with other parties. If you will not subcontract any portion of the proposed bid, do not fill out this form.

Prime Bidder: _____ Primary NAICS _____

Code: _____

Item Description (as seen on RFP): _____

Please list all Subcontractors below. Include the total dollar value that you propose to share with each subcontractor and the dollar amount to be subcontracted. Please check off MBE and WBE where applicable. The directory of all state-certified MBE/WBE firms is located at www.mbe.ri.gov. Business NAICS codes can be found at <https://www.naics.com/search/>

| Proposed Subcontractor | MBE | WBE | Primary NAICS Code | Date of Mobilization | \$ Value of Subcontract |
|--|-----|-----|--------------------|----------------------|-------------------------|
| | | | | | \$ |
| | | | | | \$ |
| | | | | | \$ |
| | | | | | \$ |
| | | | | | \$ |
| | | | | | \$ |
| A. MBE SUBCONTRACTED AMOUNT: | | | | | \$ |
| B. WBE SUBCONTRACTED AMOUNT: | | | | | \$ |
| C. NON MBE WBE SUBCONTRACTED AMOUNT: | | | | | \$ |
| D. DOLLAR AMOUNT OF WORK DONE BY THE PRIME CONTRACTOR: | | | | | \$ |
| E. TOTAL AMOUNT OF BID (SUM OF A, B, C, & D): | | | | | \$ |
| F. PERCENTAGE OF BID SUBCONTRACTED TO MBEs AND WBEs. (Divide the sum of A and B by E and multiply result by 100). | | | | | % |

Please read and initial the following statement acknowledging you understand. If the percentage of the total amount of the bid being awarded to MBE or WBE vendors is less than 20% (Box F) and the prime contractor is NOT a Rhode Island State-certified MBE or WBE, you must fill out the MBE/WBE WAIVER REQUEST FORM for consideration by City of Providence MBE/WBE Outreach Director. Initial _____

Signature of Bidder

Printed Name



**BOARD OF CONTRACT AND SUPPLY
CITY OF PROVIDENCE, RHODE ISLAND**

MBE/WBE Waiver Request Form

Fill out this form only if you are subcontracting and did not meet the 20% MBE/WBE participation goal. State-certified MBE or WBE Prime Bidders are NOT REQUIRED to fill out this form.

Submit this form to the City of Providence MBE/WBE Outreach Director, Grace Diaz, at mbe-wbe@providenceri.gov, for review **prior to bid submission**. This waiver applies only to the current bid which you are submitting to the City of Providence and does not apply to other bids your company may submit in the future.

Prime Bidder: _____

Company Trade: _____

Item Discussion (as seen on RFP):

To receive a waiver, you must list the certified MBE and/or WBE companies you contacted, the name of the primary individual with whom you interacted, and the reason the MBE/WBE company could not participate on this project.

| MBE/WBE Company Name | Individual's Name | Company Trade | Why did you choose not to work with this company? |
|----------------------|-------------------|---------------|---|
| | | | |
| | | | |
| | | | |
| | | | |
| | | | |
| | | | |
| | | | |

I acknowledge the City of Providence's goal of a combined MBE/WBE participation is 20% of the total bid value. I am requesting a waiver of _____ % MBE/WBE (20% minus the value of **Box F** on the Subcontractor Disclosure Form). If an opportunity is identified to subcontract any task associated with the fulfillment of this contract, a good faith effort will be made to select MBE/WBE certified businesses as partners.

Signature of Prime Contractor

Printed Name

Date Signed

Signature of City of Providence
MBE/WBE Outreach Director

Printed Name of City of Providence
MBE/WBE Outreach Director

Date Signed



**BOARD OF CONTRACT AND SUPPLY
CITY OF PROVIDENCE, RHODE ISLAND**

SUPPLEMENTAL INFORMATION

If the issuing department for this RFP determines that your firm's bid is best suited to accommodate their need, you will be asked to provide proof of the following prior to formalizing an award.

An inability to provide the outlined items at the request of the department may lead to the disqualification of your bid.

*This information is **NOT** requested to be provided in your initial bid that you will submit to the City Clerk's office by the "date to be opened" noted on page 1. This list only serves as a list of items that your firm should be ready to provide on request.*

All bids submitted to the City Clerk become public record. Failure to follow instructions could result in information considered private being posted to the city's Open Meetings Portal and made available as a public record.

You must be able to provide:

- Business Tax ID will be requested after an award is approved by the Board of Contract and Supply.
- Proof of Insurance



**BOARD OF CONTRACT AND SUPPLY
CITY OF PROVIDENCE, RHODE ISLAND**

BID FORM 3: Supplemental Bid Form

To whom it may concern:

1. The undersigned, having familiarized (himself) (themselves) (itself) with the **Collyer Park Improvements** bid affecting the cost of work, and with the Contract Documents (which includes the Invitation for Bids, Instructions to Bidders, Form of Bid Bond, Form of Agreements, form of Non-Collusive Affidavit, Addenda (if any), Drawings, Technical Specification, Form of Surety Bond(s); as prepared by the Providence Parks Department, and on file in the office of the City Clerk 3rd Floor, City Hall, Providence, RI 02903, hereby proposes to furnish all supervision, technical personnel, labor, materials, machinery, tools, equipment and services including utility and transportation services, and to perform such other required work for the **Collyer Park Improvements** and such other required and incidental work, complete, all in accordance with the above listed documents and for the unit prices for work in-place for the following items and quantities.

2. In submitting this Bid, the bidder understands that the right is reserved by The Providence Parks Department to reject any and all Bids, If written notice of acceptance of this Bid is mailed, telegraphed or delivered to the undersigned within (90) days after the opening thereof, or at any time thereafter before this Bid is withdrawn, the undersigned agrees to execute and deliver an Agreement in the prescribed form and furnish the required bond within (10) days after the Agreement is presented to him/her for signature.

Herewith in accordance with the instructions to Bidders.

3. Attached hereto is an affidavit in proof that the undersigned has not colluded with any person in respect to this. Bid or any bids for the Contractor for which this Bid is submitted. Also attached is a Statement of Bidder's Qualifications.

4. Application unit prices are contained in the Agreement (established as the result of either a Unit Price Bid or a Supplemental Schedule of Unit Prices), the City of Providence may order the Contractor to proceed with desired changes in the work, the value of such changes to be determined by the measured quantities involved and the application unit prices specified in the Contract.

5. The City of Providence reserves the right to determine the lowest responsible Bidder based on past experience with the City and/or recommendations by City and/or state agencies with an interest in this procurement. The City reserves the right to award the project to the appropriate bidder in the best interest of the City of Providence.

CERTIFICATION OF NON-SEGREGATED FACILITIES

The Bidder certifies that he/she does not maintain or provide for his/her employees any segregated facilities at any of his establishments, and that he/she does not permit his/her employees to perform their services at any location, under his/her control, where segregation facilities are maintained. The Bidder agrees that a breach of this certification will be a violation of the Equal Opportunity Clause in any contract resulting from acceptance of this Bid. As used in this certification, term "segregation facilities" means any waiting rooms, work rooms, rest rooms and wash rooms, restaurants and other eating areas, time clocks, locker rooms and other storage or dressing areas, parking lots, drinking fountains, recreation or entertainment areas, transportation and housing facilities provided for employee which are segregated by explicit directive or are in fact segregated on basis of race, color, religion, or national origin, because of habit, local custom, or otherwise. The Bidder agrees that (except where he/she has obtained identical certification from proposed subcontractors for specific time periods) he/she will obtain identical certification from proposed subcontractor prior to the award of subcontracts exceeding \$10,000.00 which are not exempt from provisions of the Equal Opportunity Clause, and that he /she will retain such certifications in his/her files.

NOTE: The penalty for making false statements in offers is prescribed in 18 U.S.C. & 1001.

DATE _____, 20__



**BOARD OF CONTRACT AND SUPPLY
CITY OF PROVIDENCE, RHODE ISLAND**

Name of Bidder and Official Address:

Name of Authorized Representative (Contact):

By _____
(Signature)
Title _____

E-Mail: _____

Phone: _____

Bidder shall indicate, in space provided,
the earliest possible Project Start-up Date: _____, 20 _____

ADDENDA: The undersigned acknowledges receipt of the following Addenda, if any, and has included the provisions thereof in this Bid (If Any):

| <u>Addendum No.</u> | <u>Date</u> | <u>Addendum No.</u> | <u>Date</u> |
|---------------------|----------------|---------------------|----------------|
| _____ | _____, 20 ____ | _____ | _____, 20 ____ |
| _____ | _____, 20 ____ | _____ | _____, 20 ____ |

Sub-Contractors (If Any):

Name: _____ **Scope of Work:** _____ **MBE / WBE**

Name: _____ **Scope of Work:** _____ **MBE / WBE**

Name: _____ **Scope of Work:** _____ **MBE / WBE**



**BOARD OF CONTRACT AND SUPPLY
CITY OF PROVIDENCE, RHODE ISLAND**

SUPPLEMENTAL BID FORM

COLLYER PARK IMPROVEMENTS

BASE BID: PROJECT DESCRIPTION

Collyer Park is located at the intersection of Collyer St and Cemetery St in Providence RI. The park consists of a baseball field, small playground, & wooded area. The primary focus of this project is to provide irrigation for the baseball field.

The Providence Parks Department is seeking qualified contractors to provide construction services for installing irrigation and re-seeding. Proposed work will include but is not limited to: site clearing, irrigation, chain link fence installation/repair, fence top protection, tree planting, bituminous concrete work, fine grading, & seeding.

All Contractors shall possess substantial credentials in good standing and be able to perform tasks as describe in this Bid. Contractor shall be familiar with all Local and State Regulations to ensure public health and safety.

BASE BID: The Base Bid scope of work for this project shall include, but not be limited to the following:

All Work Included in this Project Shall be Completed for the lump sum of:

_____ Dollars
(\$ _____), TOTAL BASE BID

ADD ALTERNATES:

1. Add Alt # 1 – Repair & Replace Chain Link Fence & Service Gate as Noted on Plan - Per Lump Sum

_____ LS \$ _____
price in writing

2. Add Alt # 2 – Furnish & Install Yellow Fence Top Protection along Cemetery St- Per Lump Sum

_____ LS \$ _____
price in writing

3. Add Alt # 3 –Relocate Storage Container to Location Shown on Plan- Per Lump Sum

_____ LS \$ _____
price in writing

BIDDER: _____



**BOARD OF CONTRACT AND SUPPLY
CITY OF PROVIDENCE, RHODE ISLAND**

4. Add Alt # 4 – Furnish and Install Existing Foul Poles (2) - Per Lump Sum

_____ LS \$ _____
price in writing

5. Add Alt # 5 – Furnish & Install Concrete Pad and Bleachers- Per Lump Sum

_____ LS \$ _____
price in writing

6. Add Alt # 7 – Furnish & Install Flag Pole and Base- Per Lump Sum

_____ LS \$ _____
price in writing

7. Add Alt # 7 – Furnish & Install 1 (one) Cedrus atlantica ‘Blue Cascade’ – 8-10’ B&B- Per Lump Sum

_____ LS \$ _____
price in writing

UNIT PRICES:

1. F&I Temporary Tree And Plant Protection - Per linear Foot

_____ LF \$ _____
price in writing

2. Remove & Dispose Vegetation Behind Outfield Fence - Per Lump Sum

_____ LS \$ _____
price in writing

3. Remove & Dispose Stump - Per Lump Sum

_____ LS \$ _____
price in writing

4. F&I Irrigation System per Plan & Details Complete - Per Lump Sum

_____ LS \$ _____
price in writing

BIDDER: _____



**BOARD OF CONTRACT AND SUPPLY
CITY OF PROVIDENCE, RHODE ISLAND**

5. F&I 2 (Two) 6' height 10' Sections of Chain Link Fence at Existing Openings Complete - Per Linear Foot

_____ LF \$ _____
price in writing

6. F&I Bituminous Concrete at Collyer St Entrance Complete – Per Square Foot

_____ SF \$ _____
price in writing

7. Sand & Paint 2 (Two) Existing Foul Poles – Lump Sum

_____ LS \$ _____
price in writing

8. F&I Yellow Fence Top Protection on Outfield Fence & Backstop - Per Linear Foot

_____ LF \$ _____
price in writing

9. F&I ¾" Screened Loam Installed Complete - Per Cubic Yard

_____ CY \$ _____
price in writing

10. Fine Grade ¼" Hydro Seed Complete - Per Square Foot

_____ SF \$ _____
price in writing

Please note that the list above is not intended to include all items required to complete the base bid scope of work but can and shall be used to adjust the contract prior to or after award – in the best interest of the City of Providence.

BIDDER: _____



**BOARD OF CONTRACT AND SUPPLY
CITY OF PROVIDENCE, RHODE ISLAND**

BID DOCUMENTS:

The complete set of Bid Documents consists of the Bid Form, Technical Specifications, Minority Participation Forms, and the following Drawings:

DRAWINGS:

COLLYER PARK IMPROVEMENTS

- **COVER SHEET**
- **E-1 EXISTING CONDITIONS**
- **L-1 DEMOLITION PLAN**
- **L-2 MATERIALS PLAN**
- **I-1 IRRIGATION PLAN**
- **L-3 CONSTRUCTION DETAILS**
- **I-2 IRRIGATION DETAILS**

TECHNICAL SPECIFICATION:

- **010000 General Requirements**
- **015639 Temporary Tree and Plant Protection**
- **024119 Selective Demolition**
- **107516 Ground-Set Flagpoles**
- **312316.13 Trenching**
- **321216 Asphalt Paving**
- **323133 Chain Link Fences & Gates**
- **328400 Planting Irrigation**
- **329119 Landscape Grading**
- **329200 Turf and Grasses**
- **329300 Plants**

ADDITIONAL INFORMATION REQUIRED WITH BID:

- Qualifications to Perform Work – See Form Below for Information Required
- Minority Participation Forms – 10% MBE / 10 % WBE Goal on this Project
- Addenda (If Any) - Must Be Acknowledged on Bid Form
- Product Information for Items Submitted as ‘Or Equal’ to Specified Materials

PROVISIONS OF THIS PROJECT:

- Upon the Issuance of the Award from the Board of Contract – the City shall issue a Contract to be executed by the City and the vendor incorporating the bid specifications. All Provisions of the Specifications are binding.
- Any Permits Required by the City of Providence and/or State of Rhode Island Shall be Obtained by the Vendor – Permit Fees by the City of Providence Shall be Waived – the State ADA Fee Must be Paid
- The Davis Bacon Act Applies (**HUD Projects**) – Prevailing Wages Must Be Paid for On Site Hours – On-Site Interviews will be Conducted During the Project – Employees Shall be Advised of the Prevailing Wage Rates Prior to Mobilization on Site



**BOARD OF CONTRACT AND SUPPLY
CITY OF PROVIDENCE, RHODE ISLAND**

- Certified payrolls Must be Submitted With Pay Requests Including Monthly Utilizations Form
- Performance and Payment Bonds (If Required) Must be Submitted within 10 Days of Award or Bid Bond Will be Forfeited
- An Insurance Certificate Shall be Submitted to the City Within 10 Days of Award
- A Copy of the Vendors Contractor's License Must be Submitted within 10 Days of Award
- All On-Site Personnel Shall be Licensed (If Required) and Shall have Proof of All Licenses Required by the State of Rhode Island to Perform the Work Required
- Pay Requests Must be Submitted on Approved AIA Billing Documents (City will Provide if Needed)
- All Subcontractors Shall be Listed on the Bid Form – All Insurance & Payroll Requirements Apply
 - General Contractor Shall be the Insurance Certificate Holder and the City Shall be Named as 'Additionally Insured' with Respect to Liability Insurance
- A Submittal Log Must be Submitted within 10 Days of Award

CLOSE OUT DOCUMENTS:

- Prior to Final Payment the Vendor Shall Provide the Following:
 - Copies of Permits Signed off and Approved (If Any)
 - Operating Manuals and Warranties Shall Be Transferred and/or Delivered
 - Full and Completed As-Built Drawings Shall be Submitted for Approval
 - Training Shall be Provided to City Personnel (If Required)
 - Certification by Manufactures Representative (If Required)

QUALIFICATIONS:

Qualifications will be evaluated on the basis of similar project experience for:

- a. Completion of at least 3 similar projects within the past five years.
- b. Size and dollar value of similar completed projects.
- c. Contractor's performance with similar projects. (references will be checked)
- d.. Relevant experience of individuals assigned to the project.

Questions regarding this bid package shall be submitted via e-mail to **Patti Jordan** at pjordan@providenceri.gov and **Megan Gardner, Parks Design Team Manager** at mgardner@providenceri.gov , no later than five (5) working days before the bid opening date.

Sam Greenwood is the project contact and can be reached at 401-680-7299.

This project qualifies for prevailing wages per the **Prevailing Wages Statute or the Davis Bacon Act (HUD). Certified payrolls will need to be submitted to the owner for all hours worked on site for this project. The Wage Decision for this project shall be as recorded on the Bid Date and is available on the RI Department of Labor website.**

"General Decision Number: RI20210001 09/17/2021

Superseded General Decision Number: RI20200001

State: Rhode Island

Construction Types: Building, Heavy (Heavy and Marine) and Highway

Counties: Rhode Island Statewide.

BUILDING CONSTRUCTION PROJECTS (does not include residential construction consisting of single family homes and apartments up to and including 4 stories) HEAVY, HIGHWAY AND MARINE CONSTRUCTION PROJECTS

Note: Under Executive Order (EO) 13658, an hourly minimum wage of \$10.95 for calendar year 2021 applies to all contracts subject to the Davis-Bacon Act for which the contract is awarded (and any solicitation was issued) on or after January 1, 2015. If this contract is covered by the EO, the contractor must pay all workers in any classification listed on this wage determination at least \$10.95 per hour (or the applicable wage rate listed on this wage determination, if it is higher) for all hours spent performing on the contract in calendar year 2021. If this contract is covered by the EO and a classification considered necessary for performance of work on the contract does not appear on this wage determination, the contractor must pay workers in that classification at least the wage rate determined through the conformance process set forth in 29 CFR 5.5(a)(1)(ii) (or the EO minimum wage rate, if it is higher than the conformed wage rate). The EO minimum wage rate will be adjusted annually. Please note that this EO applies to the above-mentioned types of contracts entered into by the federal government that are subject to the Davis-Bacon Act itself, but it does not apply to contracts subject only to the Davis-Bacon Related Acts, including those set forth at 29 CFR 5.1(a)(2)-(60). Additional information on contractor requirements and worker protections under the EO is available at www.dol.gov/whd/govcontracts.

| Modification Number | Publication Date |
|---------------------|------------------|
| 0 | 01/01/2021 |
| 1 | 01/22/2021 |
| 2 | 03/05/2021 |
| 3 | 04/09/2021 |
| 4 | 04/23/2021 |
| 5 | 06/18/2021 |
| 6 | 07/30/2021 |
| 7 | 09/10/2021 |
| 8 | 09/17/2021 |

ASBE0006-006 12/01/2019

Rates Fringes

HAZARDOUS MATERIAL HANDLER
(Includes preparation, wetting, stripping, removal scrapping, vacuuming, bagging & disposing of all insulation materials, whether they

contain asbestos or not, from
mechanical systems).....\$ 36.60 22.40

* ASBE0006-008 09/01/2021

Rates Fringes

Asbestos Worker/Insulator
Includes application of
all insulating materials,
protective coverings,
coatings & finishes to all
types of mechanical systems.\$ 45.00 32.89

* BOIL0029-001 01/01/2021

Rates Fringes

BOILERMAKER.....\$ 45.87 29.02

BRRIO003-001 06/01/2020

Rates Fringes

Bricklayer, Stonemason,
Pointer, Caulker & Cleaner.....\$ 42.55 28.02

BRRIO003-002 03/01/2020

Rates Fringes

Marble Setter, Terrazzo
Worker & Tile Setter.....\$ 40.78 28.92

BRRIO003-003 03/01/2020

Rates Fringes

Marble, Tile & Terrazzo
Finisher.....\$ 34.10 27.88

CARP0330-001 01/01/2021

Rates Fringes

CARPENTER (Includes Soft
Floor Layer).....\$ 39.72 28.66
Diver Tender.....\$ 40.72 28.66
DIVER.....\$ 51.47 28.66
Piledriver.....\$ 39.72 28.66
WELDER.....\$ 40.72 28.66

FOOTNOTES:

When not diving or tending the diver, the diver and diver tender shall receive the piledriver rate. Diver tenders shall receive \$1.00 per hour above the pile driver rate when tending the diver.

Work on free-standing stacks, concrete silos & public utility electrical power houses, which are over 35 ft. in height when constructed: \$.50 per hour additional.

Work on exterior concrete shear wall gang forms, 45 ft. or more above ground elevation or on setback: \$.50 per hour

additional.

The designated piledriver, known as the ""monkey"": \$1.00 per hour additional.

 CARP1121-002 01/06/2020

| | Rates | Fringes |
|-----------------|----------|---------|
| MILLWRIGHT..... | \$ 39.07 | 29.15 |

 * ELEC0099-002 06/02/2021

| | Rates | Fringes |
|--------------------------------|----------|--------------|
| ELECTRICIAN..... | \$ 43.61 | 54.71% |
| Teledata System Installer..... | \$ 32.71 | 12.57%+14.93 |

FOOTNOTES:

Work of a hazardous nature, or where the work height is 30 ft. or more from the floor, except when working OSHA-approved lifts: 20% per hour additional.

Work in tunnels below ground level in combined sewer outfall: 20% per hour additional.

 ELEV0039-001 01/01/2021

| | Rates | Fringes |
|------------------------|----------|------------|
| ELEVATOR MECHANIC..... | \$ 55.03 | 35.825+A+B |

FOOTNOTES:

A. PAID HOLIDAYS: New Years Day; Memorial Day; Independence Day; Labor Day; Veterans' Day; Thanksgiving Day; the Friday after Thanksgiving Day; and Christmas Day.

B. Employer contributes 8% basic hourly rate for 5 years or more of service of 6% basic hourly rate for 6 months to 5 years of service as vacation pay credit.

 ENGI0057-001 12/01/2020

| | Rates | Fringes |
|--|----------|---------|
| Operating Engineer: (power plants, sewer treatment plants, pumping stations, tunnels, caissons, piers, docks, bridges, wind turbines, subterranean & other marine and heavy construction work) | | |
| GROUP 1..... | \$ 42.55 | 27.70+a |
| GROUP 2..... | \$ 40.55 | 27.70+a |
| GROUP 3..... | \$ 36.17 | 27.70+a |
| GROUP 4..... | \$ 33.32 | 27.70+a |
| GROUP 5..... | \$ 39.60 | 27.70+a |
| GROUP 6..... | \$ 30.40 | 27.70+a |
| GROUP 7..... | \$ 24.40 | 27.70+a |

| | | |
|--------------|----------|---------|
| GROUP 8..... | \$ 36.25 | 27.70+a |
| GROUP 9..... | \$ 40.17 | 27.70+a |

a. BOOM LENGTHS, INCLUDING JIBS:

- 150 feet and over + \$ 2.00
- 180 feet and over + \$ 3.00
- 210 feet and over + \$ 4.00
- 240 feet and over + \$ 5.00
- 270 feet and over + \$ 7.00
- 300 feet and over + \$ 8.00
- 350 feet and over + \$ 9.00
- 400 feet and over + \$10.00

a. PAID HOLIDAYS:

New Year's Day, President's Day, Memorial Day, July Fourth, Victory Day, Labor Day, Columbus Day, Veterans Day, Thanksgiving Day, Christmas Day. a: Any employee who works 3 days in the week in which a holiday falls shall be paid for the holiday.

a. FOOTNOTES:

Hazmat work: \$2.00 per hour additional.
Tunnel/Shaft work: \$5.00 per hour additional.

POWER EQUIPMENT OPERATORS CLASSIFICATIONS

GROUP 1: Cranes, lighters, boom trucks and derricks

GROUP 2: Digging machine, Ross Carrier, locomotive, hoist, elevator, bidwell-type machine, shot & water blasting machine, paver, spreader, graders, front end loader (3 yds. and over), vibratory hammer & vacuum truck, roadheaders, forklifts, econobile type equipment, tunnel boring machines, concrete pump and on site concrete plants.

GROUP 3: Oilers on cranes.

GROUP 4: Oiler on crawler backhoe.

GROUP 5: Bulldozer, bobcats, skid steer loader, tractor, scraper, combination loader backhoe, roller, front end loader (less than 3 yds.), street and mobile-powered sweeper (3-yd. capacity), 8-ft. sweeper minimum 65 HP).

GROUP 6: Well-point installation crew.

GROUP 7: Utility Engineers and Signal Persons

GROUP 8: Heater, concrete mixer, stone crusher, welding machine, generator and light plant, gas and electric driven pump and air compressor.

GROUP 9: Boat & tug operator.

ENGI0057-002 11/01/2020

Rates Fringes

Power Equipment Operator
(highway construction projects; water and sewerline projects which are incidental

to highway construction projects; and bridge projects that do not span water)

| | | |
|--------------|----------|---------|
| GROUP 1..... | \$ 35.70 | 27.70+a |
| GROUP 2..... | \$ 30.40 | 27.70+a |
| GROUP 3..... | \$ 24.40 | 27.70+a |
| GROUP 4..... | \$ 30.98 | 27.70+a |
| GROUP 5..... | \$ 34.68 | 27.70+a |
| GROUP 6..... | \$ 34.30 | 27.70+a |
| GROUP 7..... | \$ 29.95 | 27.70+a |
| GROUP 8..... | \$ 31.33 | 27.70+a |
| GROUP 9..... | \$ 33.28 | 27.70+a |

a. FOOTNOTE: a. Any employee who works three days in the week in which a holiday falls shall be paid for the holiday.

a. PAID HOLIDAYS: New Year's Day, President's Day, Memorial Day, July Fourth, Victory Day, Labor Day, Columbus Day, Veterans Day, Thanksgiving Day & Christmas Day.

POWER EQUIPMENT OPERATOR CLASSIFICATIONS

GROUP 1: Digging machine, crane, piledriver, lighter, locomotive, derrick, hoist, boom truck, John Henry's, directional drilling machine, cold planer, reclaimer, paver, spreader, grader, front end loader (3 yds. and over), vacuum truck, test boring machine operator, veemere saw, water blaster, hydro-demolition robot, forklift, economobile, Ross Carrier, concrete pump operator and boats

GROUP 2: Well point installation crew

GROUP 3: Utlity engineers and signal persons

GROUP 4: Oiler on cranes

GROUP 5: Combination loader backhoe, front end loader (less than 3 yds.), forklift, bulldozers & scrapers and boats

GROUP 6: Roller,skid steer loaders, street sweeper

GROUP 7: Gas and electric drive heater, concrete mixer, light plant, welding machine, pump & compressor

GROUP 8: Stone crusher

GROUP 9: Mechanic & welder

 ENGI0057-003 12/01/2020

BUILDING CONSTRUCTION

| | Rates | Fringes |
|--------------------------|----------|---------|
| Power Equipment Operator | | |
| GROUP 1..... | \$ 41.82 | 27.70+a |
| GROUP 2..... | \$ 39.82 | 27.70+a |
| GROUP 3..... | \$ 39.60 | 27.70+a |
| GROUP 4..... | \$ 35.60 | 27.70+a |
| GROUP 5..... | \$ 32.75 | 27.70+a |
| GROUP 6..... | \$ 38.90 | 27.70+a |
| GROUP 7..... | \$ 38.47 | 27.70+a |
| GROUP 8..... | \$ 35.79 | 27.70+a |

a. BOOM LENGTHS, INCLUDING JIBS:

- 150 ft. and over: + \$ 2.00
- 180 ft. and over: + \$ 3.00
- 210 ft. and over: + \$ 4.00
- 240 ft. and over: + \$ 5.00
- 270 ft. and over: + \$ 7.00
- 300 ft. and over: + \$ 8.00
- 350 ft. and over: + \$ 9.00
- 400 ft. and over: + \$10.00

a. PAID HOLIDAYS: New Year's Day, President's Day, Memorial Day, July Fourth, Victory Day, Labor Day, Columbus Day, Veterans Day, Thanksgiving Day & Christmas Day. a: Any employee who works 3 days in the week in which a holiday falls shall be paid for the holiday.

- a. FOOTNOTE: Hazmat work: \$2.00 per hour additional.
Tunnel/Shaft work: \$5.00 per hour additional.

POWER EQUIPMENT OPERATORS CLASSIFICATIONS

GROUP 1: Cranes, lighters, boom trucks and derricks.

GROUP 2: Digging machine, Ross carrier, locomotive, hoist, elevator, bidwell-type machine, shot & water blasting machine, paver, spreader, front end loader (3 yds. and over), vibratory hammer and vacuum truck

GROUP 3: Telehandler equipment, forklift, concrete pump & on-site concrete plant

GROUP 4: Fireman & oiler on cranes

GROUP 5: Oiler on crawler backhoe

GROUP 6: Bulldozer, skid steer loaders, bobcats, tractor, grader, scraper, combination loader backhoe, roller, front end loader (less than 3 yds.), street and mobile powered sweeper (3 yds. capacity), 8-ft. sweeper (minimum 65 hp)

GROUP 7: Well point installation crew

GROUP 8: Heater, concrete mixer, stone crusher, welding machine, generator for light plant, gas and electric driven pump & air compressor

* IRON0037-001 09/16/2021

| | Rates | Fringes |
|-----------------|----------|---------|
| IRONWORKER..... | \$ 38.21 | 30.58 |

LABO0271-001 05/30/2021

BUILDING CONSTRUCTION

| | Rates | Fringes |
|--------------|----------|---------|
| LABORER | | |
| GROUP 1..... | \$ 33.55 | 26.15 |
| GROUP 2..... | \$ 33.80 | 26.15 |
| GROUP 3..... | \$ 34.30 | 26.15 |

| | | |
|--------------|----------|-------|
| GROUP 4..... | \$ 34.55 | 26.15 |
| GROUP 5..... | \$ 35.55 | 26.15 |

LABORERS CLASSIFICATIONS

GROUP 1: Laborer, Carpenter Tender, Mason Tender, Cement Finisher Tender, Scaffold Erector, Wrecking Laborer, Asbestos Removal [Non-Mechanical Systems]

GROUP 2: Asphalt Raker, Adzemen, Pipe Trench Bracer, Demolition Burner, Chain Saw Operator, Fence & Guard Rail Erector, Setter of Metal Forms for Roadways, Mortar Mixer, Pipelayer, Riprap & Dry Stonewall Builder, Highway Stone Spreader, Pneumatic Tool Operator, Wagon Drill Operator, Tree Trimmer, Barco-Type Jumping Tamper, Mechanical Grinder Operator

GROUP 3: Pre-Cast Floor & Roof Plank Erectors

GROUP 4: Air Track Operator, Hydraulic & Similar Self-Powered Drill, Block Paver, Rammer, Curb Setter, Powderman & Blaster

GROUP 5: Toxic Waste Remover

LAB00271-002 05/30/2021

HEAVY AND HIGHWAY CONSTRUCTION

| | Rates | Fringes |
|---|----------|---------|
| LABORER | | |
| COMPRESSED AIR | | |
| Group 1..... | \$ 53.45 | 24.15 |
| Group 2..... | \$ 50.98 | 24.15 |
| Group 3..... | \$ 40.50 | 24.15 |
| FREE AIR | | |
| Group 1..... | \$ 44.05 | 24.15 |
| Group 2..... | \$ 43.05 | 24.15 |
| Group 3..... | \$ 40.50 | 24.15 |
| LABORER | | |
| Group 1..... | \$ 33.55 | 24.15 |
| Group 2..... | \$ 33.80 | 24.15 |
| Group 3..... | \$ 34.55 | 24.15 |
| Group 4..... | \$ 27.05 | 24.15 |
| Group 5..... | \$ 35.55 | 24.15 |
| OPEN AIR CAISSON, UNDERPINNING WORK AND BORING CREW | | |
| Bottom Man..... | \$ 39.55 | 24.15 |
| Top Man & Laborer..... | \$ 38.60 | 24.15 |
| TEST BORING | | |
| Driller..... | \$ 40.00 | 24.15 |
| Laborer..... | \$ 38.60 | 24.15 |

LABORER CLASSIFICATIONS

GROUP 1: Laborer; Carpenter tender; Cement finisher tender; Wrecking laborer; Asbestos removers [non-mechanical systems]; Plant laborer; Driller in quarries

GROUP 2: Adzeperson; Asphalt raker; Barcotype jumping tamper; Chain saw operators; Concrete and power buggy operator; Concrete saw operator; Demolition burner; Fence and guard rail erector; Highway stone spreader; Laser beam

operator; Mechanical grinder operator; Mason tender; Mortar mixer; Pneumatic tool operator; Riprap and dry stonewall builder; Scaffold erector; Setter of metal forms for roadways; Wagon drill operator; Wood chipper operator; Pipelayer; Pipe trench bracer

GROUP 3: Air track drill operator; Hydraulic and similar powered drills; Brick paver; Block paver; Rammer and curb setter; Powderperson and blaster

GROUP 4: Flagger & signaler

GROUP 5: Toxic waste remover

LABORER - COMPRESSED AIR CLASSIFICATIONS

GROUP 1: Mucking machine operator, tunnel laborer, brake person, track person, miner, grout person, lock tender, gauge tender, miner: motor person & all others in compressed air

GROUP 2: Change house attendant, powder watchperson, top person on iron

GROUP 3: Hazardous waste work within the ""HOT"" zone

LABORER - FREE AIR CLASSIFICATIONS

GROUP 1: Grout person - pumps, brake person, track person, form mover & stripper (wood & steel), shaft laborer, laborer topside, outside motorperson, miner, conveyor operator, miner welder, heading motorperson, erecting operator, mucking machine operator, nozzle person, rodperson, safety miner, shaft & tunnel, steel & rodperson, mole nipper, concrete worker, form erector (wood, steel and all accessories), cement finisher (this type of work only), top signal person, bottom person (when heading is 50' from shaft), burner, shield operator and TBM operator

GROUP 2: Change house attendant, powder watchperson

GROUP 3: Hazardous waste work within the ""HOT"" zone

PAIN0011-005 06/01/2021

| | Rates | Fringes |
|---|----------|---------|
| PAINTER | | |
| Brush and Roller..... | \$ 36.42 | 22.90 |
| Epoxy, Tanks, Towers, Swing Stage & Structural Steel..... | \$ 38.42 | 22.90 |
| Spray, Sand & Water Blasting..... | \$ 39.42 | 22.90 |
| Taper..... | \$ 37.17 | 22.90 |
| Wall Coverer..... | \$ 36.92 | 22.90 |

PAIN0011-006 06/01/2021

| | Rates | Fringes |
|--------------|----------|---------|
| GLAZIER..... | \$ 39.98 | 22.90 |

FOOTNOTES:

SWING STAGE: \$1.00 per hour additional.

PAID HOLIDAYS: Labor Day & Christmas Day.

PAIN0011-011 06/01/2021

| | Rates | Fringes |
|----------------------------|----------|---------|
| Painter (Bridge Work)..... | \$ 54.00 | 22.90 |

PAIN0035-008 06/01/2011

| | Rates | Fringes |
|-------------------|----------|---------|
| Sign Painter..... | \$ 24.79 | 13.72 |

PLAS0040-001 06/03/2019

BUILDING CONSTRUCTION

| | Rates | Fringes |
|-----------------------------------|----------|---------|
| CEMENT MASON/CONCRETE FINISHER... | \$ 36.00 | 27.15 |

FOOTNOTE: Cement Mason: Work on free swinging scaffolds under 3 planks width and which is 20 or more feet above ground and any offset structure: \$.30 per hour additional.

PLAS0040-002 07/01/2019

HEAVY AND HIGHWAY CONSTRUCTION

| | Rates | Fringes |
|-----------------------------------|----------|---------|
| CEMENT MASON/CONCRETE FINISHER... | \$ 32.85 | 22.20 |

PLAS0040-003 07/01/2019

| | Rates | Fringes |
|----------------|----------|---------|
| PLASTERER..... | \$ 37.55 | 27.50 |

PLUM0051-002 08/30/2021

| | Rates | Fringes |
|-------------------------------|----------|---------|
| Plumbers and Pipefitters..... | \$ 46.49 | 31.40 |

ROOF0033-004 06/01/2021

| | Rates | Fringes |
|-------------|----------|---------|
| ROOFER..... | \$ 39.40 | 29.06 |

SFRI0669-001 04/01/2021

| | Rates | Fringes |
|-----------------------|----------|---------|
| SPRINKLER FITTER..... | \$ 47.55 | 26.60 |

SHEE0017-002 12/01/2020

| | Rates | Fringes |
|-------------------------|----------|---------|
| Sheet Metal Worker..... | \$ 38.58 | 36.73 |

TEAM0251-001 05/01/2019

HEAVY AND HIGHWAY CONSTRUCTION

| | Rates | Fringes |
|---------------|----------|---------------|
| TRUCK DRIVER | | |
| GROUP 1..... | \$ 27.96 | 26.8525+A+B+C |
| GROUP 2..... | \$ 27.61 | 26.8525+A+B+C |
| GROUP 3..... | \$ 27.66 | 26.8525+A+B+C |
| GROUP 4..... | \$ 27.71 | 26.8525+A+B+C |
| GROUP 5..... | \$ 27.81 | 26.8525+A+B+C |
| GROUP 6..... | \$ 28.21 | 26.8525+A+B+C |
| GROUP 7..... | \$ 28.41 | 26.8525+A+B+C |
| GROUP 8..... | \$ 27.91 | 26.8525+A+B+C |
| GROUP 9..... | \$ 28.16 | 26.8525+A+B+C |
| GROUP 10..... | \$ 27.96 | 26.8525+A+B+C |

FOOTNOTES:

A. Paid Holidays: New Year's Day, Memorial Day, Independence Day, Labor Day, Thanksgiving Day and Christmas Day, plus Presidents' Day, Columbus Day, Veteran's Day & V-J Day, providing the employee has worked at least one day in the calendar week in which the holiday falls.

B. Employee who has been on the payroll for 1 year or more but less than 5 years and has worked 150 Days during the last year of employment shall receive 1 week's paid vacation; 5 to 10 years - 2 weeks' paid vacation; 10 or more years - 3 week's paid vacation.

C. Employees on the seniority list shall be paid a one hundred dollar (\$100.00) bonus for every four hundred (400) hours worked, up to a maximum of five hundred dollars (\$500.00)

All drivers working on a defined hazard material job site shall be paid a premium of \$2.00 per hour over applicable rate.

TRUCK DRIVER CLASSIFICATIONS

GROUP 1: Pick-up trucks, station wagons, & panel trucks

GROUP 2: Two-axle on low beds

GROUP 3: Two-axle dump truck

GROUP 4: Three-axle dump truck

GROUP 5: Four- and five-axle equipment

GROUP 6: Low-bed or boom trailer.

GROUP 7: Trailers when used on a double hook up (pulling 2 trailers)

GROUP 8: Special earth-moving equipment, under 35 tons

GROUP 9: Special earth-moving equipment, 35 tons or over

GROUP 10: Tractor trailer

WELDERS - Receive rate prescribed for craft performing operation to which welding is incidental.

=====
Note: Executive Order (EO) 13706, Establishing Paid Sick Leave for Federal Contractors applies to all contracts subject to the Davis-Bacon Act for which the contract is awarded (and any solicitation was issued) on or after January 1, 2017. If this contract is covered by the EO, the contractor must provide employees with 1 hour of paid sick leave for every 30 hours they work, up to 56 hours of paid sick leave each year. Employees must be permitted to use paid sick leave for their own illness, injury or other health-related needs, including preventive care; to assist a family member (or person who is like family to the employee) who is ill, injured, or has other health-related needs, including preventive care; or for reasons resulting from, or to assist a family member (or person who is like family to the employee) who is a victim of, domestic violence, sexual assault, or stalking. Additional information on contractor requirements and worker protections under the EO is available at www.dol.gov/whd/govcontracts.

Unlisted classifications needed for work not included within the scope of the classifications listed may be added after award only as provided in the labor standards contract clauses (29CFR 5.5 (a) (1) (ii)).

The body of each wage determination lists the classification and wage rates that have been found to be prevailing for the cited type(s) of construction in the area covered by the wage determination. The classifications are listed in alphabetical order of "identifiers" that indicate whether the particular rate is a union rate (current union negotiated rate for local), a survey rate (weighted average rate) or a union average rate (weighted union average rate).

Union Rate Identifiers

A four letter classification abbreviation identifier enclosed in dotted lines beginning with characters other than "SU" or "UAVG" denotes that the union classification and rate were prevailing for that classification in the survey. Example: PLUM0198-005 07/01/2014. PLUM is an abbreviation identifier of the union which prevailed in the survey for this classification, which in this example would be Plumbers. 0198 indicates the local union number or district council number where applicable, i.e., Plumbers Local 0198. The next number, 005 in the example, is an internal number used in processing the wage determination. 07/01/2014 is the effective date of the most current negotiated rate, which in this example is July 1, 2014.

Union prevailing wage rates are updated to reflect all rate changes in the collective bargaining agreement (CBA) governing

this classification and rate.

Survey Rate Identifiers

Classifications listed under the ""SU"" identifier indicate that no one rate prevailed for this classification in the survey and the published rate is derived by computing a weighted average rate based on all the rates reported in the survey for that classification. As this weighted average rate includes all rates reported in the survey, it may include both union and non-union rates. Example: SULA2012-007 5/13/2014. SU indicates the rates are survey rates based on a weighted average calculation of rates and are not majority rates. LA indicates the State of Louisiana. 2012 is the year of survey on which these classifications and rates are based. The next number, 007 in the example, is an internal number used in producing the wage determination. 5/13/2014 indicates the survey completion date for the classifications and rates under that identifier.

Survey wage rates are not updated and remain in effect until a new survey is conducted.

Union Average Rate Identifiers

Classification(s) listed under the UAVG identifier indicate that no single majority rate prevailed for those classifications; however, 100% of the data reported for the classifications was union data. EXAMPLE: UAVG-OH-0010 08/29/2014. UAVG indicates that the rate is a weighted union average rate. OH indicates the state. The next number, 0010 in the example, is an internal number used in producing the wage determination. 08/29/2014 indicates the survey completion date for the classifications and rates under that identifier.

A UAVG rate will be updated once a year, usually in January of each year, to reflect a weighted average of the current negotiated/CBA rate of the union locals from which the rate is based.

WAGE DETERMINATION APPEALS PROCESS

1.) Has there been an initial decision in the matter? This can be:

- * an existing published wage determination
- * a survey underlying a wage determination
- * a Wage and Hour Division letter setting forth a position on a wage determination matter
- * a conformance (additional classification and rate) ruling

On survey related matters, initial contact, including requests for summaries of surveys, should be with the Wage and Hour Regional Office for the area in which the survey was conducted because those Regional Offices have responsibility for the Davis-Bacon survey program. If the response from this initial contact is not satisfactory, then the process described in 2.) and 3.) should be followed.

With regard to any other matter not yet ripe for the formal process described here, initial contact should be with the Branch of Construction Wage Determinations. Write to:

Branch of Construction Wage Determinations
Wage and Hour Division
U.S. Department of Labor
200 Constitution Avenue, N.W.
Washington, DC 20210

2.) If the answer to the question in 1.) is yes, then an interested party (those affected by the action) can request review and reconsideration from the Wage and Hour Administrator (See 29 CFR Part 1.8 and 29 CFR Part 7). Write to:

Wage and Hour Administrator
U.S. Department of Labor
200 Constitution Avenue, N.W.
Washington, DC 20210

The request should be accompanied by a full statement of the interested party's position and by any information (wage payment data, project description, area practice material, etc.) that the requestor considers relevant to the issue.

3.) If the decision of the Administrator is not favorable, an interested party may appeal directly to the Administrative Review Board (formerly the Wage Appeals Board). Write to:

Administrative Review Board
U.S. Department of Labor
200 Constitution Avenue, N.W.
Washington, DC 20210

4.) All decisions by the Administrative Review Board are final.

=====

END OF GENERAL DECISION"

Collyer Park Improvements

35 Collyer St
Providence, Rhode Island 02904

Table of Contents Generated by SpecBuilder: 9/30/2021

| Division | Section Title | Pages |
|----------|---------------|-------|
|----------|---------------|-------|

SPECIFICATIONS GROUP
General Requirements Subgroup

DIVISION 01 - GENERAL REQUIREMENTS

| | | |
|--------|-------------------------------------|----|
| 010000 | GENERAL REQUIREMENTS | 16 |
| 015639 | TEMPORARY TREE AND PLANT PROTECTION | 5 |

Facility Construction Subgroup

DIVISION 02 - EXISTING CONDITIONS

| | | |
|--------|----------------------|---|
| 024119 | SELECTIVE DEMOLITION | 5 |
|--------|----------------------|---|

DIVISION 10 - SPECIALTIES

| | | |
|--------|----------------------|---|
| 107516 | GROUND-SET FLAGPOLES | 4 |
|--------|----------------------|---|

Site and Infrastructure Subgroup

DIVISION 31 - EARTHWORK

| | | |
|-----------|-----------|---|
| 312316.13 | TRENCHING | 4 |
|-----------|-----------|---|

DIVISION 32 - EXTERIOR IMPROVEMENTS

| | | |
|--------|-----------------------------|----|
| 321216 | ASPHALT PAVING | 5 |
| 323113 | CHAIN LINK FENCES AND GATES | 6 |
| 328400 | PLANTING IRRIGATION | 15 |
| 329119 | LANDSCAPE GRADING | 3 |
| 329200 | TURF AND GRASSES | 7 |
| 329300 | PLANTS | 11 |

END OF TABLE OF CONTENTS



SECTION 010000 - GENERAL REQUIREMENTS

PART 1 - GENERAL

1.1 All work done under this Contract shall also be in conformance with the Drawings and these Supplemental Technical Specifications.

A. SCOPE OF WORK

1. The general summary of work to be done under this contract consists of, but shall not be limited, to the following as shown in the Contract Documents:

B. WORK COVERED BY CONTRACT DOCUMENTS

C. The Contractor shall execute the scope of work indicated on Plans and Specifications to enhance the use and operations of the site as shown within the project limits.

D. Work shall be as specifically indicated, shown or described in the Drawings, Technical Specifications, and other Contract Documents.

E. PROJECT INFORMATION

1. OWNER

a. City of Providence Parks Department Roger Williams Park Dalrymple Boathouse, 1000 Elmwood Avenue, Providence, RI 02907, Telephone: 401.680.7200

b. Superintendent of Parks: Wendy Nilsson

2. OWNER'S REPRESENTATIVE

a. Project Manager: Sam Greenwood - 401.680.7299

1.2 PROJECT LOCATION

A. Collyer Park - 35 Collyer St - Providence, RI - 02904

PART 2 - PRODUCTS

2.1 CONTRACTOR USE OF PREMISES

A. The Contractor's use of premises shall be within the limits shown on the Drawings and as defined in the Standard Form of Agreement, for the performance of the Work.

1. The Contractor shall maintain vehicular access and utility service to the abutting properties at all times throughout the course of the construction.

2. The Contractor shall assume full responsibility for security of all materials and equipment on the site, including those of the subcontractors.



3. If directed by the Owner's Representative, the Contractor shall relocate or move any stored items that interfere with operations of the Owner.
4. The Contractor may elect to obtain (at no cost to the Owner) additional storage or work areas off-site if needed to perform the work.

2.2 OWNER OCCUPANCY REQUIREMENTS

- A. The Owner (City) anticipates that site inclusive of all on-site amenities beyond the Limit of Work will remain open throughout the course of construction.
- B. Contractor shall provide the Owner's Representative with a written plan describing the sequences and durations anticipated for the execution of the Work.

2.3 MOBILIZATION, SITE PREPARATION, & DEMOLITION

- A. THE WORK SPECIFIED IN THIS SECTION INCLUDES:
 1. Mobilization of all personnel and equipment;
 2. Preparing the construction site for construction operations;
 3. Materials to be removed and legally disposed of off site.
 4. When applicable, verifying and utilizing survey control points as shown on the Drawings
 5. Protecting existing site features to remain, such as fences, trees, shrubs and grassed areas outside the limit of work.
 6. Protecting underground and overhead utilities and other existing facilities from damage.
 7. Where applicable, provisions for site access and of traffic control.
 8. At cessation of site improvement operations: Site clean-up
 9. De-mobilization of all personnel and equipment.

2.4 CONSTRUCTION STAGING/STOCKPILE AREAS

- A. Staging areas within the Park is permitted as shown on the Plans with the prior consent of and coordination with the Owner.
- B. Restoration of the site to pre-existing condition shall be the sole responsibility of the Contractor.

2.5 MATERIALS AND EQUIPMENT:

- A. Materials to be Removed and Stockpiled.
 1. Materials directed to be removed and stockpiled shall be removed, transported to and stacked in a location directed by the Owner's Representative. All materials shall be neatly stacked as directed.
 2. If the Owner's Representative determines that any part of the materials identified to be stockpiled are unsuitable for re use on the site or by the Owner elsewhere, such materials shall be evaluated for legal disposal by Owner's Representative and Contractor.
- B. Signs: Conform to requirements of Temporary Facilities and Controls.



- C. Temporary Site Protection: Temporary chain-link fence, if so desired shall be furnished, installed and maintained at no additional cost to the Owner. At the completion of all work at the site, the Contractor shall remove all temporary fencing and restore the site to its original condition at no additional cost to the Owner.

2.6 TEMPORARY CONSTRUCTION FACILITIES AND UTILITIES

- A. Make arrangements with the Owner's Representative for storage of materials and equipment in designated locations at the construction site. If staged on site, materials shall be secured from vandalism and or theft.
- B. Plastic construction fence or snow fencing if installed shall be maintained in good condition. Provide barricades, barrels, fencing and/or other barriers around excavations and trenches as required for safety. Upon completion, temporary fencing shall be removed and the affected area restored to the existing condition.

2.7 SITE MAINTENANCE

- A. Control dust from Contractor operations in accordance with specified dust control measures.
- B. Maintain the Site during construction in a manner that will not obstruct use on neighborhood streets. Proceed with the work in an orderly manner, maintaining the construction site free of debris and unnecessary equipment or materials.
- C. Legally dispose of all debris, rubbish, hazardous materials, oil, and grease in accordance with local ordinances.
- D. Maintain safety and security of the construction site and any stockpiled or staged materials or equipment if left on site.

2.8 TRAFFIC CONTROL

- A. For all of his operations, the Contractor shall provide appropriate traffic control in accordance with, TEMPORARY FACILITIES AND CONTROLS. The purposes of the traffic control are 1) to ensure that operations in the project area are performed in a safe and orderly manner, and 2) to minimize the impact of truck and equipment traffic and noise on adjacent homes near the project area. The Contractor shall be responsible for obtaining any and all required permits and approvals.
- B. Police Details, if required by the City, shall be paid directly to and coordinated with Providence Public Safety by the Owner.

2.9 DEMOBILIZATION

- A. Contractor shall be responsible for site security and safety at all times. Upon substantial completion of the work, Contractor shall remove all excess materials, equipment, construction debris, temporary facilities and construction measures (fencing, signs, barriers, etc.) from the project area, and shall leave the site in suitable condition for full occupancy and use by the Owner.



The sedimentation and erosion controls installed as part of the Work may not necessarily be removed at this time (see below).

- B. The Owner's Representative shall be the sole judge of whether the site has been suitably cleaned.
- C. Upon suitable stabilization of all disturbed "erodible" areas (e.g. acceptable level of grass growth in loamed and seeded areas, mulch applied and stable in planting areas, etc.), contractor shall remove and legally dispose of all sedimentation and erosion control measures (silt fence, hay bales, catch basin inserts, etc.). See Section 024119 Selective Demolition and 329200 Turf and Grasses for directives and procedures.

PART 3 - EXECUTION

3.1 GENERAL REQUIREMENTS

- A. The construction site entrance shall be as indicated on the plans. The Owner will provide access to any locked gate. Any tracked debris from the site present on adjacent roadways shall be removed and the roads swept daily to remove any excess mud, dirt, or rock originating from the site. Trucks hauling material shall be covered and equipped with gates that prevent material from falling out. If present, catch basins within 100 feet of site entry and exit locations shall be protected with inlet sediment control devices and maintained for the duration of the work.
- B. Identify, clearly mark and protect all survey monuments, temporary bench marks as well as any adjacent contractors' work and facilities (if applicable). Repair or replacement shall be at Contractor's sole expense if damaged by Contractor.
- C. Protect existing culverts, sewers, and all other utilities including gas, telecommunications, electricity, and water. Repair or replace at Contractor's sole expense if damaged by Contractor.
- D. Utilize or install drum or sawhorse barricades or backfill all open excavations, holes, trenches, and depressions occurring at construction sites or occurring as part of this work.

3.2 CHANGE ORDER PROCEDURE

A. DESCRIPTION

- 1. The Contractor shall comply with this procedure in the process of giving notification of change and preparing and submitting a proposal for adjustment due to a desired, perceived, or actual change in the work. Changes in the work, or period of performance of the work, may be directed in writing by the Owner's Representative or may be requested by the Contractor. In either case, payment for work accomplished under a modification may not be made until a formal contract modification, incorporating the change into the contract, has been issued and executed. Therefore, it is incumbent upon the Contractor to comply fully with this procedure and to expedite the resolution of changes.



3.3 CHANGE SUBMITTALS

- A. When requested, the Contractor shall submit the following to the Owner's Representative in accordance with the Submittals procedures described in these specifications:
 - 1. Proposal cover letter on Contractor's letterhead;
 - 2. Detailed price proposal;
 - 3. Drawings or other explanatory data; and
 - 4. Time extension statement with justification if any time extension is requested.

3.4 COMPLIANCE

- A. The Contractor shall take such measures as needed to assure familiarity and compliance by its staff with these procedures. If change proposals are incomplete, unclear, or ambiguous or are not supported by adequate documentation, the data will be returned and the Contractor shall resubmit or supplement the proposal as requested by the Owner's Representative. Delay resulting from the Contractor's noncompliance with this procedure shall not in itself constitute the basis for an extension in the time of performance under the contract.

3.5 PROCESSING CHANGES INITIATED BY THE OWNER'S REPRESENTATIVE

- A. The Owner's Representative will initiate changes only in writing. The Owner will sign any Request for Proposal (RFP). This will establish an Extra Work Order (EWO) number, by which the change will be identified until such time as it may be incorporated into the contract by formal Change Order (CO).
- B. The Contractor may or may not be authorized to proceed with the changed work pending resolution of changes in the contract price or time of performance. If the work described in the RFP becomes critical to the timely performance of the Contractor's work, a written request for a Notice to Proceed must be forwarded to the Owner immediately. The Owner will issue any Notice to Proceed. This unilateral modification to the contract may be subject to further negotiation regarding price and time for completion.
- C. Payment for changed work, covered by an authorized modification, will not be made until a notice to proceed covering the changed work has been executed.
- D. The Contractor shall prepare and submit its proposal for change to include at a minimum:
 - 1. A cover letter referencing the EWO number and citing the attachments, if any, which constitute the Contractor's total proposal.
 - 2. A detailed price proposal showing labor, construction equipment, and material quantities and prices at the lowest practical level of each element of the work.
 - 3. Any drawings, sketches, catalog cuts, samples, certifications, or other data required to be submitted by the Owner's Representative that is required to fully document
 - 4. A statement of the proposed change in the time of completion of the contract, together with all required justification for such a change.
 - 5. A statement to the effect that there is "no change in price and/or time of completion of the work under this contract as a result of this proposed change", if that is the case.



- E. The Owner may accept the Contractor's proposal without negotiation. Alternatively, upon receipt of a proposal which is satisfactory in form, the Owner's Representative may require negotiation with the Contractor to arrive at a fair and equitable change in the contract price and time of completion. Upon agreement, a contract modification will be issued by the Owner for Contractor's execution.

3.6 PROCESSING CHANGES INITIATED BY THE CONTRACTOR

- A. Should the Contractor feel that a change to the work under the contract, or to the contract itself, is necessary or desirable, it shall propose such a change to the Owner's Representative. This proposed change shall include a clear and concise description of the proposed change, along with that information cited in above.
- B. Within a reasonable time, the Owner's Representative will review the Contractor's proposal and determine if the proposed change is in the Owner's best interest. If so, Contractor will be advised of this and a an EWO number will be assigned to Contractor's proposal.

3.7 EXECUTING CHANGED WORK

- A. The Contractor is cautioned not to proceed with the work described in a proposed change until it is authorized to do so in writing by the Owner's Representative.

3.8 TERMINATIONS AND DELAYS

- A. Termination of Contract: If the Contractor or any of his/her subcontractors refuses or fails to prosecute the work with such diligence as will insure its completion within the time specified in these Contract Documents, or as modified, as provided for in these Contract Drawings, or violates any other Provisions of this Contract, the Local Public Agency, Local Public Agency, City, by written notice to the Contractor, may terminate the Contractor's right to proceed with the Work. Upon such termination, the City of Providence may take over the work and prosecute the same to completion, by contract or otherwise, and the Contractor and his/her sureties shall be liable to the City of Providence for any additional cost incurred by the City of Providence in its completion of the work and they shall also be liable to the City of Providence for liquidated damages for any delay in the completion of the work as provided below. work and they shall also be liable to the City of Providence for liquidated damages for any delay work. in the completion of the work as provided below. work. If the Contractor's right to proceed is so terminated, the Local Public Agency Local Public Agency City may take possession of and utilize in completing the work such materials, tools, equipment, and plants as may be on the site of the work and necessary thereof. Project work must commence 30 days after award of Contract or as mutually agreed upon by the Contractor and the Owner. The Contractor is required to submit a Work Schedule including all items included in the scope of work. The Work Schedule shall mirror the Schedule of Values which should be in chronological order. Both items are identified in the standard Pre-Bid and Pre-Construction Meeting Minutes as required. The work shall be continuous and the Contractor shall staff the project appropriately to meet the agreed upon work schedule. De- Mobilization from the project, prior to completion, must be agreed upon in writing by the Owner.



3.9 INSPECTION OF WORK

A. DESCRIPTION

1. Work included in this Section consists of periodic observation of construction of the project. The Contractor's work shall be monitored periodically by the Owner's Representative
2. The Owner's Representative presence on site or construction observation work is inspectional in nature and will not include supervision or direction of the actual work of the contractor.
3. In no event will the Owner's Representative be responsible or liable for the contractor's use or administration of personnel, machinery, staging, or other temporary or precautionary construction, safety precautions or procedures, or for compliance by the contractor with the provisions, terms, or specifications of the contract. Observation services provided by the Owner's Representative are solely for the benefit of the Owner.
4. The Contractor shall keep the Owner's Representative informed concerning the work status and projected work schedule through regular communications.
5. The Contractor shall not cover any work related to the required field visits until one of the following occurs:
 - a. The Contractor is authorized by the Owner's Representative to proceed after the field visit.
 - b. The field visit is re-scheduled by the Owner's Representative to a later construction event
 - c. The field visit is waived in writing by the Owner's Representative
6. The Contractor shall request a Final Inspection seven calendar days in advance of the planned completion date. After review of the Notice of Completion, the Owner's Representative may reject the Notice for cause or schedule the Final Inspection. The Owner's Representative will perform its Final Inspection on all phases of the work and develop a comprehensive punch list, which will be provided to the Contractor.
7. The Final Inspection will be scheduled when the punch list items discovered during the Final Inspection have been corrected. If discovered, the Owner's Representative may add new items to the punch list at this inspection.
8. The Contractor is advised that the Owner's Representative will not accept the work until the Owner's Representative determines Substantial Completion has been achieved. Therefore, to minimize its risk, the Contractor should schedule its work to be substantially complete in time to allow the Final Inspection and punch list work to occur in advance of the Project Close Out Date. Due to the construction time period and the anticipated weather conditions, substantially complete will be defined as the completion of construction for all item and the temporary stabilization of all disturbed areas, excluding planting and final seeding. Planting and final seeding is to occur during the time periods specified..
9. Nothing in this Section shall be construed to limit the Owner's Representative right to inspect the work at any time.

3.10 CONSTRUCTION SCHEDULES

A. DESCRIPTION

1. Work included in this Section consists of preparation, submittal, and updating of the project.



3.11 CONSTRUCTION SCHEDULE

- A. Submit the following to the Owner's Representative in accordance with the Submittals Section. Submittals are for the record or approval as indicated.
 - 1. The proposed construction schedule shall be submitted for approval within five (5) calendar days after receipt of Notice to Proceed.
 - 2. Submit contract Weekly Summary Reports to the Owner's Representative for the record at weekly site meeting at request by the Owner.
 - 3. Submit construction progress schedule including a three week look ahead as back up to progress invoices.
- B. The construction schedule shall show all work activities for completion of the work to be performed under this contract and will reflect Contractor's general sequential approach to the work. The construction schedule will be in a bar chart format. The minimum level of detail (number of activities) shall include the activities described in the Schedule of Values and the Scope of the Work. The construction schedule shall demonstrate completion of all work within the period of performance of the contract in a reasonable and achievable manner.

3.12 PERIODIC SCHEDULE UPDATES

- A. The Contractor shall support monthly payment requests with an approved construction schedule marked to indicate progress. Submit updated schedule as necessary.
- B. When in the opinion of the Owner's Representative changes in the work occur that significantly affect the schedule, the Contractor shall submit a revised construction schedule for approval. The revised construction schedule shall be submitted within 10 calendar days after it is requested by the Owner's Representative. The current approved construction schedule shall be used as a baseline for progress reporting.
- C. Acts of God: Claims for additional compensation for 'Acts of God' will be reviewed by the Owner. It is the Contractor's responsibility to secure the work site daily and failure to provide adequate provisions to do so may result in repairs to the site at the Contractor's expense. Documented 'Acts of God' such as the state issuing a 'State of Emergency' may result in the Owner's authorization to proceed repair funded by the Owner. No work shall proceed without written authorization by the Owner.

3.13 SUBMITTAL PROCEDURES

- A. DESCRIPTION
 - 1. This Specification Section covers the preparation and submission of all work plans, drawings, samples, manufacturer's literature and brochures, installation instructions, and operation and maintenance manuals as specified herein and in the various sections of these Specifications.
 - 2. A Submittal Schedule shall be submitted for approval within five (5) calendar days after receipt of Notice to Proceed.



3.14 DRAWINGS

- A. The term "drawings" as used herein includes 'Shop Drawings' as required for fabrication, erection and installation, layout, and setting of proposed improvements; lists or schedules of materials and catalogues and brochures; performance and test data; and all other drawings and descriptive data pertaining to materials and methods of construction as may be required to show that the materials, equipment, or systems and the positions thereof conform to the requirements of the Contract Documents.
- B. Where specified and if so directed by the Owner's Representative provide shop drawings that are accompanied by design computations.
- C. Sheet sizes of drawings shall not exceed 24 in. by 36 in. The title block on all drawings shall bear the name of the Owner, the name of the project, and the project location.
- D. The Contractor's drawings shall be submitted electronically in PDF format to the Owner's Representative for review and approval.
- E. The Contractor shall maintain a complete set of construction drawings at the jobsite, clearly marked to reflect as-built conditions. Upon completion of the work, the Contractor shall submit these Record Drawings to the Owner's Representative.
- F. The Owner's Representative will review drawings and schedules only for conformance with the design of the Project and for compliance with the Contract Documents and Contract Drawings. The Contractor shall make any and all updates and corrections required by the Owner's Representative
- G. Drawings shall be reviewed and returned within ten (10) working days of receipt of drawings at jobsite. Drawings and all supporting data, catalogs, or similar information shall be prepared by the Contractor or his suppliers and subcontractors but shall be submitted as instruments of the Contractor.
- H. The Owner's Representative review of drawings will be of a general nature and shall not relieve the Contractor from responsibility for errors and omissions of any sort, for deviations from Drawings or Specifications, or for conflict with the work of others that may result from such deviations. The Owner's Representative review of drawings will not relieve the Contractor of responsibility to complete the work in accordance with the requirements of the Contract Documents.
- I. After Notice of Award, the Contractor shall submit a Submittal Schedule to the Owner's Representative. The Contractor's schedule shall be brought up to date from time to time to show the latest changes, omissions, and additions. The Schedule will be based on the Contractor's Construction Schedule and will show when the Contractor will submit the drawings and when he/she expects them to be returned so that construction activities shown on the Construction Schedule are not interrupted. There will be a minimum of three weeks between these two activities. Specific methods and routines for handling drawing reviews shall be established in advance within the general framework of the Contract Documents.
- J. Work for which the Contractor's submittals are required shall not be started until the submittals have been reviewed and accepted in writing by the Owner's Representative. Any revision by the



Contractor of a previously accepted submittal must be accepted in writing by the Owner's Representative before implementation.

3.15 SAMPLES

- A. The Contractor shall, at his or her expense, furnish the Owner's Representative with samples of the various materials as specified in these Specification and Drawings. Samples shall be delivered to the office of the Owner's Representative at the Contractor's expense.

3.16 PRODUCT DATA

- A. The Contractor shall submit to the Owner's Representative all required Material Safety Data Sheets (MSDS) and all Product Data Sheets and any other relevant product information for all items identified in the Technical Specifications and Drawings. All data shall be furnished by the Contractor in accordance with the approved schedule.

B. SUBMITTAL LOG

- 1. Contractor to provided the following information:
 - a. An I.D. number for each item
 - b. Specification Section, Paragraph Number and Line Item Number (ie. 321313 / 1.3 / A)
 - c. Item Name
 - d. Description of the Item
 - e. Date Submitted
 - f. Status: Approved / Approved As Noted / Rejected
 - g. Sub-Contractor (If any) providing the material
 - h. Comments

3.17 QUALITY CONTROL DESCRIPTION

- A. This Section provides the requirements for Contract quality control (QC) pertaining to the Work, including:
 - 1. QC of products and workmanship;
 - 2. Manufacturer's instructions; and
 - 3. Manufacturer's certificates and field services.

3.18 WORKMANSHIP

- A. The Contractor shall comply with industry standards of the region, except when more restrictive tolerances or specified requirements indicate more rigid standards or more precise workmanship.
- B. The Contractor shall provide suitably-qualified personnel to produce work of specified quality.
- C. The Contractor shall secure products in place with positive anchorage devices designed and sized to withstand stresses, vibration, and racking.



- D. The Contractor shall provide materials to match approved samples.

3.19 MANUFACTURER'S INSTRUCTIONS

- A. The Contractor shall require compliance with instructions in full detail, including each step in sequence. Should instructions conflict with the Contract Documents, the Contractor shall request clarification from the Owner's Representative before proceeding.

3.20 MANUFACTURER'S CERTIFICATES

- A. When required in individual Specifications sections, the Contractor shall submit manufacturer's certificates, in duplicate, certifying that products meet or exceed specified requirements.

3.21 TESTING LABORATORY SERVICES (NIC)

- A. Not Utilized in this Contract
- B. (Modify as Required)

3.22 MANUFACTURER'S FIELD SERVICES

- A. When required by the manufacturer or Owner's Representative, the Contractor shall have the manufacturer provide a qualified representative to observe field conditions, conditions of surfaces and installation, and quality of workmanship as applicable and to make written report of observations and recommendations to the Owner's Representative

3.23 AUTHORITY OF OWNER'S REPRESENTATIVE

- A. The Owner's Representative will decide all questions that may arise as to the quality and acceptability of materials furnished. All questions that may arise as to the interpretation of the Contract Drawing and Specifications shall be determined by the Owner's Representative.
- B. The Owner and Owner's Representative shall not be responsible for the Contractor's means, methods, techniques, sequences, or procedures of construction or the safety precautions and programs incident thereto, and the Owner's Representative will not be responsible for the Contractor's failure to perform the work in accordance with the Contract Documents.
- C. The Owner's Representative will not be responsible for the acts or omissions of the Contractor or any subcontractors, of the agents or employees of any Contractor or subcontractor, or of any other persons at the site or otherwise performing any of the work.

3.24 COORDINATION OF DRAWINGS AND SPECIFICATIONS

- A. The Contractor shall take no advantage of any apparent error or omission in the Contract Drawings or Specifications. In the event the Contractor discovers such a discrepancy, error or



omission, he shall immediately notify the Owner's Representative. After review and consultation with the Owner's Representative the Owner's Representative will issue clarifications, provide interpretations and make such corrections as may be deemed necessary for the Contractor to proceed with fulfilling the intent of the Contract Drawings and Specifications.

- B. When general reference is made on the Contract Drawings or within the Specifications to any cited Standard Specifications, it shall refer to the current edition of such Specifications or the latest revision thereof or interim Specifications adopted and in effect on the date of Effective Date of Agreement. In the event of a conflict between the Contract Drawings and the specifications, the Owner's Representative shall be notified to provide a clarification to the Contractor.

3.25 COOPERATION WITH UTILITIES

- A. The Contractor will notify all utility companies, all pipeline owners, or other parties affected and endeavor to have all necessary adjustments of the public or private utility fixtures, pipelines, and other appurtenances within or adjacent to the limits of construction made as soon as practical.
- B. Water lines, gas lines, wire lines, service connections, water and gas meter boxes, water and gas valve boxes, light standards, cableways, signals, and all other utility appurtenances within the limits of the proposed construction which are to be crossed, relocated or adjusted are to be moved by the Contractor or its designated agents, except as otherwise noted on the Contract Drawings. In the case of utility lines, the Contractor shall coordinate with the respective utilities for their removal and relocation.
- C. Attention is directed to the possible existence of underground facilities not known to the Owner's Representative or in a location different from that which is shown on the Contract Drawings. The Contractor shall take steps to ascertain the exact location of all underground facilities prior to doing work that may damage such facilities or interfere with their service.

3.26 INDEPENDENT TESTING AND INSPECTION (NIC)

- A. Not Applicable under this Contract

3.27 REQUIREMENTS

- A. The requirements for sampling and testing or inspection are specified in the Specifications and Drawings. The Contractor shall maintain a complete and up-to-date file of all quality control documentation at the jobsite.

3.28 MATERIAL AND EQUIPMENT

A. DESCRIPTION

- 1. This Specification Section includes the requirements for the transportation, handling, storage, and protection of materials and equipment as specified herein and in the various Sections of these Specifications. This Section also addresses the procedure for Contractor-proposed product substitutions.



3.29 MANUFACTURER REQUIREMENTS

- A. In general, the Contractor shall receive, handle, and store materials and equipment in accordance with manufacturer's recommendations and in a manner which will protect such items from damage or deterioration.
- B. GENERAL
- C. Products include the material, equipment, and systems used on this Project. Comply with the Specifications, Drawings and referenced standards as minimum requirements.

3.30 TRANSPORTATION AND HANDLING

- A. The Contractor shall receive, handle, and store materials and equipment supplied by him/her in a manner that will protect such items from damage or deterioration in accordance with procedures provided by product manufacturers and the Owner.
- B. Promptly inspect the shipments to assure that the products comply with requirements, the quantities are correct, and the products are undamaged.

3.31 STORAGE AND PROTECTION

- A. Materials and equipment shall be stored off the ground on blocking or pallets and shall be covered for protection from vandalism and weather damage.
- B. Materials and equipment shall be stored, tested, and cleaned prior to use, in accordance with the Specification and all specific manufacturers' requirements. Damaged or nonconforming items shall be removed immediately to a separated storage area for expeditious removal from site.
- C. The Contractor shall provide a secure outside storage area in the vicinity of the site.

3.32 SUBSTITUTIONS

- A. Substitutions will be considered only when a product becomes unavailable due to no fault of the Contractor or when deemed appropriate by the Owner's Representative
- B. Document each request with complete data substantiating the compliance of the proposed substitution with the Contract Documents.
- C. The requested substitution proposed constitutes a representation that the Contractor:
 - 1. Has investigated the proposed product and determined that it meets or exceeds, in all respects, the specified product.
 - 2. Will provide the same warranty for substitution as for the specified product.
 - 3. Will coordinate installation and make other changes which may be required for the Work to be complete in all respects.
 - 4. Waives claims for additional costs which may subsequently become apparent.



- D. Substitutions will be considered when they are indicated or implied on shop drawings or product data submittals without separate written request, or when acceptance will require substantial revision of the Contract Documents.
- E. The Owner's Representative will determine acceptability of the proposed substitution, and will notify the Contractor of acceptance or rejection in writing within a reasonable time. Only one request for the substitution will be considered for each product. When substitution is not accepted, the Contractor shall provide the specified product.

3.33 REJECTED MATERIALS AND DEFECTIVE WORK

- A. Materials furnished by the Contractor and rejected by the Owner's Representative as unsuitable or not in conformity with the specifications shall forthwith be removed from the job-site and work area by the Contractor, and shall not be made use of elsewhere in the work.
- B. Any errors, defects, or omissions in the execution of work or in the materials furnished by the Contractor, even though they may have been passed or overlooked or have appeared after the completion of the work, discovered at any time before the final payment is made hereunder, shall be forthwith rectified and made good by and at the expense of the Contractor and in a manner satisfactory to the Owner or Owner's Representative.
- C. The Contractor shall reimburse the Owner for any expense, losses or damages incurred in consequence of any defect error, omission or act of the Contractor or his employees, as determined by the Owner's Representative, occurring previous to the final payment.

3.34 PROJECT CLOSEOUT

A. DESCRIPTION

- 1. This Section specifies administrative and procedural requirements for the project closeout including, but not limited to:
 - a. Project record document (As-Built drawings) submittal. Maintain a clean, undamaged set of blue or black line white-prints of Contract Drawings and Shop Drawings. Mark the set to show the actual installation where the installation varies substantially from the Work as originally shown. Mark whichever drawing is most capable of showing conditions fully and accurately; where Shop Drawings are used, record a cross-reference at the corresponding location on the Contract Drawings. Give particular attention to concealed elements that would be difficult to measure and record at a later date.
 - b. Organize record drawing sheets into manageable sets, bind with durable paper cover sheets, and print suitable titles, dates and other identification on the cover of each set. Upon completion of work, submit record drawings to the Owner's Representative.
- 2. Record Specifications
 - a. Maintain one complete copy of the Project Manual, including addenda. Mark these documents to show substantial variations in actual Work performed in comparison with the Specifications and modifications. Give particular attention to substitutions, selection of options and similar information on elements that are concealed or cannot



otherwise be readily discerned later by direct observation. Note related record drawing information and Product Data. Upon completion of the Work, submit record Specifications.

3. Test Results
 - a. Not Applicable this project
4. REMOVAL OF PROTECTION
 - a. Remove temporary protection and facilities installed for protection of the Work during construction. Fencing and erosion and sediment control measures and best management practices can be removed after permanent measures have been established.

3.35 WARRANTIES

A. DESCRIPTION

1. This Section specifies general administration and procedural requirements for warranties and bonds required by the Contract Documents, including manufacturers' standard warranties on products and special warranties.
 - a. Refer to the General Conditions for terms of the Contractor's special warranty of workmanship and materials;
 - b. General closeout requirements are included in Section "Project Closeout"; and
 - c. Specific requirements for warranties for the Work and products and installations that are specified to be warranted are included in the specifications and Drawings.
2. Disclaimers and Limitations
 - a. Manufacturer's disclaimers and limitations on product warranties do not relieve the Contractor of the warranty on the Work that incorporates the products, nor does it relieve suppliers, manufacturers, and subcontractors required to countersign special warranties with the Contractor.

B. DEFINITIONS

1. Standard Warranties
 - a. Standard product warranties are pre-printed written warranties published by individual manufacturers for particular products and are specifically endorsed by the manufacturer to the Owner.
2. Special Warranties
 - a. Special warranties are written required by or incorporated in the Contract Documents, either to extend time limits provided by standard warranties or to provide greater rights for the Owner.

C. WARRANTY REQUIREMENTS

1. Related Damages and Losses
 - a. When correcting warranted Work that has failed, remove and replace other Work that has been damaged as a result of such failure or that must be removed and replaced to provide access for corrections of warranted Work.
2. Reinstatement of Warranty



- a. When Work covered by a warranty has failed and been corrected by replacement or rebuilding, reinstate the warranty by written endorsement. The reinstated warranty shall be equal to the original warranty with an equitable adjustment for depreciation.
3. Replacement Cost
 - a. Upon determination that Work covered by a warranty has failed, replace or rebuild the Work to an acceptable condition complying with requirements of Contract Documents. The Contractor is responsible for the cost of replacing or rebuilding defective Work regardless of whether the Owner's Representative has benefited from use of the Work through a portion of its anticipated useful service life.
4. Owner's Recourse
 - a. Written warranties made to the Owner are in addition to implied warranties, and shall not limit the duties, obligations, rights and remedies otherwise available under the law, nor shall warranty periods be interpreted as limitations on time in which the Owner can enforce such other duties, obligations, rights and remedies.
5. Rejection of Warranties
 - a. The Owner's Representative reserves the right to reject warranties and to limit selections to products with warranties not in conflict with requirements of the Contract Documents. The Owner's Representative reserves the right to refuse to accept Work for the Project where a special warranty, certification, or similar commitment is required on such Work or part of the Work, until evidence is presented that entities required to counter sign such commitments are willing to do so.
 - b. All warranties shall be submitted to the Owner in accordance with conditions of the Contract and the Submittals.

D. WARRANTY PERIOD

1. All warranties required by the Contract documents shall commence on the date of Final Acceptance.
2. Warranty period is one (1) year from date of Final Acceptance unless otherwise specified.

END OF SECTION 010000



SECTION 015639 - TEMPORARY TREE AND PLANT PROTECTION

PART 1 - GENERAL

1.1 RELATED DOCUMENTS

- A. Drawings and general provisions of the Contract, including General Requirements, apply to this Section.

1.2 SUMMARY

- A. Section includes general protection and pruning of existing trees and plants that are affected by execution of the Work, whether temporary or permanent construction.
- B. Related Requirements:
 - 1. Section 311000 "Site Clearing" for removing existing trees and shrubs.

1.3 DEFINITIONS

- A. (DBH): Diameter breast height; diameter of a trunk as measured by the average of the smallest and largest diameters at a height **54 inches** above the ground line for trees with caliper of **8 inches** or greater as measured at a height of **12 inches** above the ground.
- B. Plant-Protection Zone: Area surrounding individual trees, shrubs, or other vegetation to be protected during construction and indicated on Drawings.
- C. Tree-Protection Zone: Area surrounding individual trees or groups of trees to be protected during construction and indicated on Drawings .
- D. Vegetation: Trees, shrubs, groundcovers, grass, and other plants.

1.4 PRE- CONSTRUCTION MEETINGS

- A. Pre-construction Conference: Conduct conference at Project site .
 - 1. Review methods and procedures related to temporary tree and plant protection including, but not limited to, the following:
 - a. Tree-service firm's personnel, and equipment needed to make progress and avoid delays.
 - b. Arborist's responsibilities.
 - c. Coordination of Work and equipment movement with the locations of protection zones.
 - d. Trenching by hand or with air spade within protection zones.
 - e. Field quality control and maintenance.



- f. Coordination by Parks Department City Forester and Forestry crews.

1.5 ACTION SUBMITTALS

- A. Contractor shall arrange site visit with City Forester prior to mobilization to determine the scope of pruning by the Parks Department Forestry Division or Contractor as indicated on the drawings.

1.6 QUALITY ASSURANCE

- A. Arborist Qualifications: Licensed arborist in jurisdiction where Project is located .

1.7 FIELD CONDITIONS

- A. The following practices are prohibited within protection zones:
1. Storage of construction materials, debris, or excavated material.
 2. Moving or parking vehicles or equipment.
 3. Foot traffic.
 4. Erection of sheds or structures.
 5. Impoundment of water.
 6. Excavation or other digging unless otherwise indicated.
 7. Attachment of signs to or wrapping materials around trees or plants unless otherwise indicated.
- B. Prohibit heat sources, flames, ignition sources, and smoking within or near protection zones and organic mulch.

PART 2 - PRODUCTS

2.1 MATERIALS

- A. Backfill Soil: Stockpiled soil mixed with planting soil of suitable moisture content and granular texture for placing around tree; free of stones, roots, plants, sod, clods, clay lumps, pockets of coarse sand, concrete slurry, concrete layers or chunks, cement, plaster, building debris, and other extraneous materials harmful to plant growth.
1. Mixture: Well-blended mix of two parts stockpiled soil to one part planting soil .
- B. Protection-Zone Fencing: Fencing fixed in position and meeting the following requirements:
1. Plastic Protection-Zone Fencing: Plastic construction fencing constructed of high-density extruded and stretched polyethylene fabric with **2-inch** maximum opening in pattern and weighing a minimum of **0.4 lb/ft.**; remaining flexible from **minus 60 to plus 200 deg F**; inert to most chemicals and acids; minimum tensile yield strength of **2000 psi** and ultimate tensile strength of **2680 psi**; secured with plastic bands or galvanized-steel or stainless-steel



wire ties; and supported by tubular or T-shape galvanized-steel posts spaced not more than 96 inches apart.

- a. Height: 72 inches .
- b. Color: High-visibility orange, nonfading.

PART 3 - EXECUTION

3.1 PREPARATION

- A. Protect tree root systems from damage caused by runoff or spillage of noxious materials while mixing, placing, or storing construction materials. Protect root systems from ponding, eroding, or excessive wetting caused by dewatering operations.

3.2 PROTECTION ZONES

- A. Protection-Zone Fencing: Install protection-zone fencing along edges of protection zones before materials or equipment are brought on the site and construction operations begin in a manner that will prevent people from easily entering protected areas except by entrance gates. Construct fencing so as not to obstruct safe passage or visibility at vehicle intersections where fencing is located adjacent to pedestrian walkways or in close proximity to street intersections, drives, or other vehicular circulation.
- B. Protection-Zone Signage: Install protection-zone signage in visibly prominent locations in a manner approved by Owner's Representative. Install one sign on protection-zone fencing. Sign to read "Tree Protection Zone - Do not Disturb". Sign to be printed on 24"x 36" white panel with black lettering at a minimum of 3" height lettering .
- C. Maintain protection zones free of trash.
- D. Maintain protection-zone fencing in good condition as acceptable by Owner's Representative and remove when construction operations are complete and equipment has been removed from the site.
 1. Do not remove protection-zone fencing, even temporarily, to allow deliveries or equipment access through the protection zone.
 2. Temporary access is permitted subject to preapproval in writing by Owner's Representative if a root buffer effective against soil compaction is constructed as directed by Owner's Representative. Maintain root buffer so long as access is permitted.

3.3 EXCAVATION

- A. General: Excavate at edge of protection zones and for trenches indicated within protection zones according to requirements in Section 312000 "Earth Moving" unless otherwise indicated.
- B. Trenching within Protection Zones: Where utility trenches are required within protection zones, excavate under or around tree roots by hand or with air spade, or tunnel under the roots as directed



by Owner's Representative. Do not cut main lateral tree roots or taproots larger than 2" without direction from Owner's Representative; cut only smaller roots that interfere with installation of utilities. Cut roots as required for root pruning. If excavating by hand, use narrow-tine spading forks to comb soil and expose roots.

- C. Redirect roots in backfill areas where possible. If encountering large, main lateral roots, expose roots beyond excavation limits as required to bend and redirect them without breaking. If encountered immediately adjacent to location of new construction and redirection is not practical, cut roots approximately **3 inches** back from new construction and as required for root pruning.
- D. Do not allow exposed roots to dry out before placing permanent backfill. Provide temporary earth cover and wrap with dampened burlap. Water and maintain in a moist condition. Temporarily support and protect roots from damage until they are permanently relocated and covered with soil or as directed by Owner's Representative.

3.4 ROOT PRUNING

- A. Prune tree roots that are affected by temporary and permanent construction. Prune roots as follows:
 - 1. Cut roots manually by digging a trench and cutting exposed roots with sharp pruning instruments; do not break, tear, chop, or slant the cuts. Do not use a backhoe or other equipment that rips, tears, or pulls roots.
 - 2. No roots larger than two (2) inches in diameter may be cut without permission of the City Forester. Cuts must be made with hand-pruner, handsaws, or chainsaws.
 - 3. Temporarily support and protect roots from damage until they are permanently redirected and covered with soil.
 - 4. Cover exposed roots with burlap and water regularly.
 - 5. Backfill as soon as possible according to requirements in Section 312000 "Earth Moving."
- B. Root Pruning within Protection Zone: Clear and excavate by hand or with air spade to the depth of the required excavation to minimize damage to tree root systems. If excavating by hand, use narrow-tine spading forks to comb soil to expose roots. Cleanly cut roots as close to excavation as possible.

3.5 REGRADING

- A. Lowering Grade: Where new finish grade is indicated below existing grade around trees, slope grade beyond the protection zone. Maintain existing grades within the protection zone.
- B. Lowering Grade within Protection Zone: Where new finish grade is indicated below existing grade around trees, slope grade away from trees as recommended by Owner's Representative unless otherwise indicated.
 - 1. Root Pruning: Prune tree roots exposed by lowering the grade. Do not cut main lateral roots or taproots; cut only smaller roots. Cut roots as required for root pruning.



- C. Minor Fill within Protection Zone: Where existing grade is 2 inches or less below elevation of finish grade, fill with backfill soil. Place backfill soil in a single uncompacted layer and hand grade to required finish elevations.

3.6 REPAIR AND REPLACEMENT

- A. General: Repair or replace trees, shrubs, and other vegetation indicated to remain or to be relocated that are damaged by construction operations, in a manner approved by Owner's Representative.
 - 1. Submit details of proposed pruning and repairs.
 - 2. Perform repairs of damaged trunks, branches, and roots within 24 hours according to arborist's written instructions.
 - 3. Replace trees and other plants that cannot be repaired and restored to full-growth status, as determined by Owner's Representative. Replacement trees to be equal to the total diameter of mature tree by multiple equal diameter specimens.
- B. Trees: Remove and replace trees that have been damaged during construction operations that Owner's Representative determines are incapable of restoring to normal growth pattern.
 - 1. Small Trees: Provide new trees of same size and species as those being replaced for each tree that measures 4" or smaller in caliper size.
 - 2. Large Trees: Provide multiple trees of 2-1/2" - 3" caliper size to equal total diameter of tree being replaced. .
 - a. Species: As determined by Owner's Representative.
 - 3. Plant and maintain new trees as specified in Section 329300 "Plants."
- C. Soil Aeration: Where directed by Owner's Representative, aerate surface soil compacted during construction. Aerate to loosen soil 10 feet beyond drip line and no closer than 36" to tree trunk with air spade.

3.7 DISPOSAL OF SURPLUS AND WASTE MATERIALS

- A. Disposal: Remove excess excavated material, displaced trees, trash, and debris and legally dispose of them off Owner's property.

END OF SECTION 015639



SECTION 024119 - SELECTIVE DEMOLITION

PART 1 - GENERAL

1.1 RELATED DOCUMENTS

- A. Drawings and general provisions of the Contract, including General and Supplementary Conditions and Division 01 Specification Sections, apply to this Section.

1.2 SUMMARY

- A. Section Includes:

- 1. Demolition and removal of selected site elements.
- 2. Salvage of existing items to be reused or recycled.

- B. Related Requirements:

- 1. Section 015639 "Temporary Tree and Plant Protection" for temporary protection of existing trees and plants that are affected by selective demolition.

1.3 DEFINITIONS

- A. Remove: Detach items from existing construction and legally dispose of them off-site unless indicated to be salvaged or reinstalled.
- B. Remove and Stockpile: Detach items from existing construction, in a manner to prevent damage, and deliver to Owner, ready for reuse or store on a per project basis. .
- C. Remove and Reinstall: Detach items from existing construction, in a manner to prevent damage, prepare for reuse, and reinstall where indicated.
- D. Existing to Remain: Leave existing items that are not to be removed and that are not otherwise indicated to be salvaged or reinstalled.
- E. Dismantle: To remove by disassembling or detaching an item from a surface, using gentle methods and equipment to prevent damage to the item and surfaces; disposing of items unless indicated to be salvaged or reinstalled.

1.4 MATERIALS OWNERSHIP

- A. Unless otherwise indicated, demolition waste becomes property of Contractor.



- B. Historic items, relics, antiques, and similar objects including, but not limited to, cornerstones and their contents, commemorative plaques and tablets, and other items of interest or value to Owner that may be uncovered during demolition remain the property of Owner.

- 1. Carefully salvage in a manner to prevent damage and promptly return to Owner.

1.5 PRE-CONSTRUCTION MEETINGS

- A. Pre-construction Conference: Conduct conference at Project site .

1.6 INFORMATIONAL SUBMITTALS

- A. Schedule of Selective Demolition Activities: Indicate the following:

- 1. Detailed sequence of selective demolition and removal work, with starting and ending dates for each activity. Ensure Owner's on-site uses are uninterrupted.
 - 2. Interruption of utility services. Indicate how long utility services will be interrupted.
 - 3. Coordination for shutoff, capping, and continuation of utility services.
 - 4. Coordination of Owner's continuing use of portions of existing site and of Owner's partial use of completed Work.

- B. Predemolition Photographs or Video: Show existing conditions of adjoining construction, including finish surfaces, that might be misconstrued as damage caused by demolition operations. Comply with Section 013233 "Photographic Documentation." Submit before Work begins.

- C. Warranties: Documentation indicating that existing warranties are still in effect after completion of selective demolition.

1.7 FIELD CONDITIONS

- A. Conditions existing at time of inspection for bidding purpose will be maintained by Owner as far as practical.

- 1. Before selective demolition, Owner will remove the items specifically indicated on the drawings

- B. Notify Owner's Representative of discrepancies between existing conditions and Drawings before proceeding with selective demolition.

- C. Hazardous Materials: It is not expected that hazardous materials will be encountered in the Work.

- 1. Hazardous materials will be removed by Owner before start of the Work.
 - 2. If suspected hazardous materials are encountered, do not disturb; immediately notify Architect and Owner. Hazardous materials will be removed by Owner under a separate contract.

- D. Utility Service: Maintain existing utilities indicated to remain in service and protect them against damage during selective demolition operations.



1.8 WARRANTY

- A. Existing Warranties: Remove, replace, patch, and repair materials and surfaces cut or damaged during selective demolition, by methods and with materials and using approved contractors so as not to void existing warranties. Notify warrantor before proceeding.
- B. Notify Owner on completion of selective demolition, and obtain documentation verifying that existing system has been inspected and warranty remains in effect. Submit documentation at Project closeout.

1.9 COORDINATION

PART 2 - PRODUCTS

2.1 PERFORMANCE REQUIREMENTS

- A. Regulatory Requirements: Comply with governing EPA notification regulations before beginning selective demolition. Comply with hauling and disposal regulations of authorities having jurisdiction.
- B. Standards: Comply with ASSE A10.6 and NFPA 241.

PART 3 - EXECUTION

3.1 EXAMINATION

- A. Verify that utilities have been disconnected and capped before starting selective demolition operations.
 - 1. Contact Dig Safe and Provide Dig Safe number to Owner prior to mobilization.
- B. Review Project Record Documents of existing construction or other existing condition and hazardous material information provided by Owner. Owner does not guarantee that existing conditions are same as those indicated in Project Record Documents.
 - 1. Meet with Owner's Representative to identify local utilities prior to mobilization.
- C. Survey of Existing Conditions: Record existing conditions by use of preconstruction photographs. measured drawings .
 - 1. Comply with requirements specified in Section 013233 "Photographic Documentation."
 - 2. Inventory and record the condition of items to be removed and salvaged. Provide photographs or video of conditions that might be misconstrued as damage caused by salvage operations. Notify Owner's Representative of damaged items.



3. Before selective demolition or removal of existing elements that will be reproduced or duplicated in final Work, make permanent record of measurements, materials, and construction details required to make exact reproduction.

3.2 PROTECTION

- A. Temporary Protection: Provide temporary barricades and other protection required to prevent injury to people and damage to adjacent buildings and facilities to remain.
 1. Provide protection to ensure safe passage of people around selective demolition area and to and from occupied portions of the site.
- B. Remove temporary barricades and protections where hazards no longer exist.

3.3 SELECTIVE DEMOLITION, GENERAL

- A. General: Demolish and remove existing construction only to the extent required by new construction and as indicated. Use methods required to complete the Work within limitations of governing regulations and as follows:
 1. Neatly cut openings and holes plumb, square, and true to dimensions required. Use cutting methods least likely to damage construction to remain or adjoining construction. Use hand tools or small power tools designed for sawing or grinding, not hammering and chopping. Temporarily cover openings to remain.
 2. Dispose of demolished items and materials promptly and legally off site.
- B. Site Access and Temporary Controls: Conduct selective demolition and debris-removal operations to ensure minimum interference with roads, streets, walks, walkways, and other adjacent occupied and used facilities.
- C. Removed and Reinstalled Items:
 1. Clean and repair items to functional condition adequate for intended reuse.
 2. Protect items from damage during transport and storage.
 3. Reinstall items in locations indicated. Comply with installation requirements for new materials and equipment. Provide connections, supports, and miscellaneous materials necessary to make item functional for use indicated.

3.4 DISPOSAL OF DEMOLISHED MATERIALS

- A. Remove demolition waste materials from Project site and dispose of legally.
 1. Do not allow demolished materials to accumulate on-site.
 2. Remove and transport debris in a manner that will prevent spillage on adjacent surfaces and areas.
- B. Burning: Do not burn demolished materials.



3.5 CLEANING

- A. Clean adjacent structures and improvements of dust, dirt, and debris caused by selective demolition operations. Return adjacent areas to condition existing before selective demolition operations began.

END OF SECTION 024119



SECTION 107516 - GROUND-SET FLAGPOLES

PART 1 - GENERAL

1.1 RELATED DOCUMENTS

- A. Drawings and general provisions of the Contract, including General and Supplementary Conditions and Division 01 Specification Sections, apply to this Section.

1.2 SUMMARY

- A. Section includes ground-set flagpoles made from fiberglass.
- B. Owner-Furnished Material: Flags.

1.3 ACTION SUBMITTALS

- A. Product Data: For each type of product.
 - 1. Include construction details, material descriptions, dimensions of individual components and profiles, operating characteristics, fittings, accessories, and finishes for flagpoles.
- B. Shop Drawings: For flagpoles.
 - 1. Include plans, elevations, and attachment details. Show general arrangement, jointing, fittings, accessories, grounding, anchoring, and support.
 - 2. Include section, and details of foundation system.

1.4 CLOSEOUT SUBMITTALS

- A. Operation and Maintenance Data: For flagpoles to include in operation and maintenance manuals.

1.5 DELIVERY, STORAGE, AND HANDLING

- A. Spiral wrap flagpoles with heavy paper and enclose in a hard fiber tube or other protective container.



PART 2 - PRODUCTS

2.1 MANUFACTURERS

- A. Source Limitations: Obtain flagpoles as complete units, including fittings, accessories, bases, and anchorage devices, from single source from single manufacturer.

2.2 PERFORMANCE REQUIREMENTS

- A. Structural Performance: Flagpole assemblies, including anchorages and supports, shall withstand design loads indicated within limits and under conditions indicated.
 - 1. Base flagpole design on nylon or cotton flags of maximum standard size suitable for use with flagpole or flag size indicated, whichever is more stringent.

2.3 FIBERGLASS FLAGPOLES

- A. Fiberglass Flagpoles: Cone -tapered flagpoles fabricated from polyester resin reinforced with woven glass-fiber roving with 75 percent of glass fibers parallel to length of flagpole.
 - 1. Manufactured by American Flag and Gift, model HG30IH or Approved Equal
- B. Exposed Height: 30 feet .
- C. Construct flagpoles in one piece if possible. If more than one piece is necessary, comply with the following:
 - 1. Fabricate shop and field joints without using fasteners, screw collars, or lead calking.
 - 2. Provide flush hairline joints using self-aligning, snug-fitting, internal sleeves.
- D. Sleeve for Fiberglass Flagpole: Fiberglass foundation sleeve, made to fit flagpole, for casting into concrete foundation.
 - 1. Flashing Collar: Same material and finish as flagpole.

2.4 FITTINGS

- A. Finial Ball: Flush-seam ball, sized as indicated or, if not indicated, to match flagpole-butt diameter.
 - 1. 0.063-inch spun aluminum with gold anodic finish.
- B. Internal Halyard, Cam Cleat System: 5/16-inch- diameter, braided polypropylene halyard; cam cleat; and concealed revolving truck assembly with plastic-coated counterweight and sling. Furnish flush access door secured with cylinder lock. Finish truck assembly to match flagpole.
 - 1. Halyard Flag Snaps: Stainless-steel swivel snap hooks. Furnish two per halyard.



2.5 MISCELLANEOUS MATERIALS

- A. Sand: ASTM C33/C33M, fine aggregate.
- B. Bituminous Paint: Cold-applied asphalt emulsion complying with ASTM D1187/D1187M.

2.6 FIBERGLASS FINISHES

- A. Fiberglass: UV-light stable, hard, high-gloss gel coat or high-gloss, high-build polyurethane or polyester coating.
 - 1. Color: White .

PART 3 - EXECUTION

3.1 PREPARATION

- A. Prepare uncoated metal flagpoles that are set in foundation tubes by painting below-grade portions with a heavy coat of bituminous paint.
- B. Foundation Excavation: Excavate to neat clean lines in undisturbed soil. Remove loose soil and foreign matter from excavation and moisten earth before placing concrete. Place and compact drainage material at excavation bottom.
- C. Provide forms where required due to unstable soil conditions and for perimeter of flagpole base at grade. Secure and brace forms to prevent displacement during concreting.
- D. Foundation Tube: Place foundation tube, center, and brace to prevent displacement during concreting. Place concrete. Plumb and level foundation tube and allow concrete to cure.
- E. Sleeves: Locate and secure sleeves in forms by bracing to reinforcement and forms.
- F. Place concrete, as specified in Section 033000 "Cast-in-Place Concrete." Compact concrete in place by using vibrators. Moist-cure exposed concrete for no fewer than seven days or use nonstaining curing compound.
- G. Trowel exposed concrete surfaces to a smooth, dense finish, free of trowel marks, and uniform in texture and appearance. Provide positive slope for water runoff to perimeter of concrete base.

3.2 FLAGPOLE INSTALLATION

- A. General: Install flagpoles where indicated and according to manufacturer's written instructions.
- B. Foundation Tube: Place flagpole in tube, seated on bottom plate between steel centering wedges, and install hardwood wedges to secure flagpole in place. Place and compact sand in foundation tube and remove hardwood wedges. Seal top of foundation tube with a 2-inch layer of elastomeric joint sealant and cover with flashing collar.



- C. Baseplate: Cast anchor bolts in concrete foundation. Install baseplate on washers placed over leveling nuts on anchor bolts and adjust until flagpole is plumb. After flagpole is plumb, tighten retaining nuts and fill space under baseplate solidly with nonshrink, nonmetallic grout. Finish exposed grout surfaces smooth and slope 45 degrees away from edges of baseplate.

END OF SECTION 107516



SECTION 312316.13 - TRENCHING

PART 1 - GENERAL

1.1 SUMMARY

A. Section Includes:

1. Excavating trenches for utilities and irrigation
2. Compacted fill from top of utility bedding to subgrade elevations .
3. Backfilling and compaction.

B. Related Sections:

1. Section 329119 - Landscape Grading: Filling of topsoil over backfilled trenches to finish grade elevation.
2. 328400 - Planting Irrigation

1.2 UNIT PRICE - MEASUREMENT AND PAYMENT

A. Trenching:

1. Basis of Measurement: By cubic yard.
2. Basis of Payment: Includes excavating to required elevations, and Over Excavating: Payment is not made for over excavated work nor for replacement materials.

1.3 REFERENCES

A. American Association of State Highway and Transportation Officials:

1. AASHTO T180 - Standard Specification for Moisture-Density Relations of Soils Using a 4.54-kg (10-lb) Rammer and a 457-mm (18-in.) Drop.

B. ASTM International:

1. ASTM D698 - Standard Test Method for Laboratory Compaction Characteristics of Soil Using Standard Effort (12,400 ft-lbf/ft³ (600 kN-m/m³).
2. ASTM D1556 - Standard Test Method for Density and Unit Weight of Soil in Place by the Sand-Cone Method.
3. ASTM D1557 - Standard Test Methods for Laboratory Compaction Characteristics of Soil Using Modified Effort (56,000 ft-lbf/ft³ (2,700 kN-m/m³).
4. ASTM D2167 - Standard Test Method for Density and Unit Weight of Soil in Place by the Rubber Balloon Method.
5. ASTM D2922 - Standard Test Method for Density of Soil and Soil-Aggregate in Place by Nuclear Methods (Shallow Depth).



6. ASTM D3017 - Standard Test Method for Water Content of Soil and Rock in Place by Nuclear Methods (Shallow Depth).

1.4 DEFINITIONS

- A. Utility: Any buried pipe, duct, conduit, or cable.

1.5 SUBMITTALS

- A. Section 013300 - Submittal Procedures: Requirements for submittals.
- B. Excavation Protection Plan: Describe sheeting, shoring, and bracing materials and installation required to protect excavations and adjacent structures and property; include structural calculations to support plan.

1.6 QUALITY ASSURANCE

- A. Perform Work in accordance with RIDOT standards.

1.7 FIELD MEASUREMENTS

- A. Verify field measurements prior to fabrication.

1.8 COORDINATION

- A. Verify Work associated with lower elevation utilities is complete before placing higher elevation utilities.

PART 2 - PRODUCTS

PART 3 - EXECUTION

3.1 LINES AND GRADES

- A. Lay pipes to lines and grades indicated on Drawings.
 1. Architect/Engineer reserves right to make changes in lines, grades, and depths of utilities when changes are required for Project conditions.
- B. Use laser-beam instrument with qualified operator to establish lines and grades.



3.2 PREPARATION

- A. Call Local Utility Line Information service at 1-888-DIG-SAFE not less than seven working days before performing Work.
 - 1. Request underground utilities to be located and marked within and surrounding construction areas.
- B. Identify required lines, levels, contours, and datum locations.
- C. Protect plant life, lawns, and other features remaining as portion of final landscaping.
- D. Protect bench marks, fences, sidewalks, paving, and curbs from excavating equipment and vehicular traffic.
- E. Maintain and protect above and below grade utilities indicated to remain.
- F. Establish temporary traffic control when trenching is performed in public right-of-way. Relocate controls as required during progress of Work.

3.3 TRENCHING

- A. Excavate subsoil required for utilities to irrigation system
- B. Remove lumped subsoil, boulders, and rock above **6" in diameter**.
- C. Perform excavation in accordance with State & Local requirements.
- D. Do not advance open trench more than **200 feet** ahead of installed pipe.
- E. Cut trenches sufficiently wide to enable installation and allow inspection. Remove water or materials that interfere with Work.
- F. Excavate bottom of trenches maximum **2 feet** wider than outside diameter of pipe.
- G. Excavate trenches to depth indicated on Drawings. Provide uniform and continuous bearing and support for bedding material and pipe.
- H. Trim excavation. Remove loose matter.
- I. Correct areas over excavated areas with compacted backfill as specified for authorized excavation or replace with fill concrete as directed by Architect/Engineer.
- J. Remove excess subsoil not intended for reuse, from site.

3.4 BACKFILLING

- A. Backfill trenches to contours and elevations with unfrozen fill materials.



- B. Systematically backfill to allow maximum time for natural settlement. Do not backfill over porous, wet, frozen, or spongy subgrade surfaces.
- C. Place fill material in continuous layers and compact .
- D. Maintain optimum moisture content of fill materials to attain required compaction density.
- E. Do not leave more than **50 feet** of trench open at end of working day.
- F. Protect open trench to prevent danger to the public .

3.5 TOLERANCES

- A. Top Surface of General Backfilling: Plus or minus **1 inch (0.08 feet)** from required elevations.

3.6 PROTECTION OF FINISHED WORK

- A. Section 017000 - Execution and Closeout Requirements: Protecting finished work.
- B. Reshape and re-compact fills subjected to vehicular traffic during construction.

END OF SECTION 312316.13



SECTION 321216 - ASPHALT PAVING

PART 1 - GENERAL

1.1 RELATED DOCUMENTS

- A. Drawings and general provisions of the Contract, including General Requirements apply to this Section.

1.2 SUMMARY

- A. Section Includes:

- 1. Hot-mix asphalt paving.

- B. Related Requirements:

- 1. Section 024119 "Selective Demolition" for demolition and removal of existing asphalt pavement.

1.3 UNIT PRICES

- A. Work of this Section is affected by Square Foot .

1.4 ACTION SUBMITTALS

- A. Product Data: For each type of product.

- 1. Include technical data and tested physical and performance properties.
 - 2. Job-Mix Designs: Certification, by authorities having jurisdiction, of approval of each job mix proposed for the Work.

1.5 INFORMATIONAL SUBMITTALS

- A. Qualification Data: For manufacturer .

1.6 QUALITY ASSURANCE

- A. Manufacturer Qualifications: RIDOT Standard Specifications for Road & Bridge Construction, latest edition .



- B. Regulatory Requirements: Comply with materials, workmanship, and other applicable requirements of RIDOT Standard Specifications for Road & Bridge Construction, latest edition for asphalt paving work.
 - 1. Measurement and payment provisions and safety program submittals included in standard specifications do not apply to this Section.

1.7 FIELD CONDITIONS

- A. Environmental Limitations: Do not apply asphalt materials if subgrade is wet or excessively damp, if rain is imminent or expected before time required for adequate cure, or if the following conditions are not met:
 - 1. Asphalt Base Course: Minimum surface temperature of 40 deg F and rising at time of placement.
 - 2. Asphalt Surface Course: Minimum surface temperature of 50 deg F at time of placement.

PART 2 - PRODUCTS

2.1 AGGREGATES

- A. General: Use materials and gradations that have performed satisfactorily in previous installations.
- B. Coarse Aggregate: ASTM D 692/D 692M, sound; angular crushed stone, crushed gravel, or cured, crushed blast-furnace slag.
- C. Fine Aggregate: ASTM D 1073 , sharp-edged natural sand or sand prepared from stone, gravel, cured blast-furnace slag, or combinations thereof.
 - 1. For hot-mix asphalt, limit natural sand to a maximum of 20 percent by weight of the total aggregate mass.
- D. Mineral Filler: ASTM D 242/D 242M , rock or slag dust, hydraulic cement, or other inert material.

2.2 ASPHALT MATERIALS

- A. Water: Potable.

2.3 MIXES

- A. Hot-Mix Asphalt: Dense-graded, hot-laid, hot-mix asphalt plant mixes ; designed according to procedures in AI MS-2, "Asphalt Mix Design Methods"; and complying with the following requirements:



1. Provide mixes with a history of satisfactory performance in geographical area where Project is located.
2. Surface Course: CRS-2 .

PART 3 - EXECUTION

3.1 EXAMINATION

- A. Verify that subgrade is dry and in suitable condition to begin paving.
- B. Proceed with paving only after unsatisfactory conditions have been corrected.

3.2 PREPARATION

- A. Protection: Provide protective materials, procedures, and worker training to prevent asphalt materials from spilling, coating, or building up on curbs, driveway aprons, manholes, and other surfaces adjacent to the Work.
- B. Proof-roll subgrade below pavements with heavy pneumatic-tired equipment to identify soft pockets and areas of excess yielding. Do not proof-roll wet or saturated subgrades.
 1. Completely proof-roll subgrade in one direction. Limit vehicle speed to **3 mph**.
 2. Proof roll with a loaded 10-wheel, tandem-axle dump truck weighing not less than **15 tons**.
 3. Excavate soft spots, unsatisfactory soils, and areas of excessive pumping or rutting, as determined by Architect, and replace with compacted backfill or fill as directed.

3.3 SURFACE PREPARATION

- A. Immediately before placing asphalt materials, remove loose and deleterious material from substrate surfaces. Ensure that prepared subgrade is ready to receive paving.

3.4 PLACING HOT-MIX ASPHALT

- A. Machine place hot-mix asphalt on prepared surface, spread uniformly, and strike off. Place asphalt mix by hand in areas inaccessible to equipment in a manner that prevents segregation of mix. Place each course to required grade, cross section, and thickness when compacted.
 1. Place hot-mix asphalt surface course in single lift.
 2. Spread mix at a minimum temperature of **250 deg F**.
 3. Begin applying mix along centerline of crown for crowned sections and on high side of one-way slopes unless otherwise indicated.
 4. Regulate paver machine speed to obtain smooth, continuous surface free of pulls and tears in asphalt-paving mat.
- B. Place paving in consecutive strips not less than **8 feet** wide unless infill edge strips of a lesser width are required.



1. After first strip has been placed and rolled, place succeeding strips and extend rolling to overlap previous strips. Overlap mix placement about **1 to 1-1/2 inches** from strip to strip to ensure proper compaction of mix along longitudinal joints.
 2. Complete a section of asphalt base course before placing asphalt surface course.
- C. Promptly correct surface irregularities in paving course behind paver. Use suitable hand tools to remove excess material forming high spots. Fill depressions with hot-mix asphalt to prevent segregation of mix; use suitable hand tools to smooth surface.

3.5 COMPACTION

- A. General: Begin compaction as soon as placed hot-mix paving will bear roller weight without excessive displacement. Compact hot-mix paving with hot, hand tampers or with vibratory-plate compactors in areas inaccessible to rollers.
1. Complete compaction before mix temperature cools to **185 deg F**.
- B. Breakdown Rolling: Complete breakdown or initial rolling immediately after rolling joints and outside edge. Examine surface immediately after breakdown rolling for indicated crown, grade, and smoothness. Correct laydown and rolling operations to comply with requirements.
- C. Intermediate Rolling: Begin intermediate rolling immediately after breakdown rolling while hot-mix asphalt is still hot enough to achieve specified density. Continue rolling until hot-mix asphalt course has been uniformly compacted to the following density:
1. Average Density: 96 percent of reference laboratory density according to ASTM D 6927 , but not less than 94 percent or greater than 100 percent.
 2. Average Density: 92 percent of reference maximum theoretical density according to ASTM D 2041/D 2041M, but not less than 90 percent or greater than 96 percent.
- D. Finish Rolling: Finish roll paved surfaces to remove roller marks while hot-mix asphalt is still warm.
- E. Edge Shaping: While surface is being compacted and finished, trim edges of pavement to proper alignment. Bevel edges while asphalt is still hot; compact thoroughly.
- F. Repairs: Remove paved areas that are defective or contaminated with foreign materials and replace with fresh, hot-mix asphalt. Compact by rolling to specified density and surface smoothness.
- G. Protection: After final rolling, do not permit vehicular traffic on pavement until it has cooled and hardened.
- H. Erect barricades to protect paving from traffic until mixture has cooled enough not to become marked.



3.6 INSTALLATION TOLERANCES

- A. Pavement Thickness: Compact each course to produce the thickness indicated within the following tolerances:
 - 1. Surface Course: Plus **1/4 inch**, no minus.

- B. Pavement Surface Smoothness: Compact each course to produce a surface smoothness within the following tolerances as determined by using a **10-foot** straightedge applied transversely or longitudinally to paved areas:
 - 1. Surface Course: **1/8 inch**.

3.7 WASTE HANDLING

- A. General: Handle asphalt-paving waste according to approved waste management plan required in Section 017419 "Construction Waste Management and Disposal."

END OF SECTION 321216



SECTION 323113 - CHAIN LINK FENCES AND GATES

PART 1 - GENERAL

1.1 RELATED DOCUMENTS

- A. Drawings and general provisions of the Contract, including General and Supplementary Conditions and Division 01 Specification Sections, apply to this Section.

1.2 SUMMARY

- A. Section Includes:

- 1. Chain-link fences.
- 2. Swing gates.

- B. Related Requirements:

- 1. [Section 033053 "Miscellaneous Cast-in-Place Concrete"] for cast-in-place concrete and post footings.

1.3 PREINSTALLATION MEETINGS

- A. Preinstallation Conference: Conduct conference at Project site .

- 1. Review Scope of Work for repairs and new installation of fences and gates .

1.4 ACTION SUBMITTALS

- A. Product Data: For each type of product.

- 1. Include construction details, material descriptions, dimensions of individual components and profiles, and finishes for the following:
 - a. Fence and gate posts, rails, and fittings.
 - b. Chain-link fabric, reinforcements, and attachments.
 - c. Accessories: Fence-top Protection Device .
 - d. Gates and hardware.

1.5 INFORMATIONAL SUBMITTALS

- A. Product Data Sheet .



1.6 FIELD CONDITIONS

- A. Field Measurements: Verify layout information for chain-link fences and gates shown on Drawings in relation to property survey and existing structures. Verify dimensions by field measurements.

1.7 WARRANTY

- A. Special Warranty: Installer agrees to repair or replace components of chain-link fences and gates that fail in materials or workmanship within specified warranty period.
 - 1. Failures include, but are not limited to, the following:
 - a. Failure to comply with performance requirements.
 - b. Deterioration of metals, metal finishes, and other materials beyond normal weathering.
 - 2. Warranty Period: Five years from date of Substantial Completion.

PART 2 - PRODUCTS

2.1 CHAIN-LINK FENCE FABRIC

- A. General: Provide fabric in one-piece heights measured between top and bottom of outer edge of selvage knuckle or twist according to "CLFMI Product Manual" and requirements indicated below:
 - 1. Fabric Height: As indicated on Drawings.
 - 2. Steel Wire for Fabric: Wire diameter of 9 Gauge .
 - a. Mesh Size: **2 inches** .
 - b. Zinc-Coated Fabric: ASTM A 392, Type II, Class 2, **2.0 oz./sq. ft.** with zinc coating applied after weaving.
 - 3. Selvage: Knuckled at both selvages .

2.2 FENCE FRAMEWORK

- A. Posts and Rails : ASTM F 1043 for framework, including rails, braces, and line; terminal; and corner posts. Provide members with minimum dimensions and wall thickness according to ASTM F 1043 or ASTM F 1083 based on the following:
 - 1. Fence Height: As indicated on Drawings .
 - 2. Horizontal Framework Members: top and bottom rails according to ASTM F 1043.
 - a. Top Rail: 1- 5/8" Diameter .
 - 3. Metallic Coating for Steel Framework:
 - a. Coatings: Any coating above.



2.3 TENSION WIRE

- A. Metallic-Coated Steel Wire: **7 Gauge** diameter, marcelled tension wire according to ASTM A 817 or ASTM A 824, with the following metallic coating:
 - 1. Type II: Zinc coated (galvanized) by hot-dip process, with the following minimum coating weight:
 - a. Matching chain-link fabric coating weight.

2.4 SWING GATES

- A. General: ASTM F 900 for gate posts and double swing gate types.
 - 1. Gate Leaf Width: As indicated .
 - 2. Framework Member Sizes and Strength: Based on gate fabric height as indicated .
- B. Pipe and Tubing:
 - 1. Zinc-Coated Steel: ASTM F 1043 and ASTM F 1083; protective coating and finish to match fence framework .
 - 2. Gate Posts: Round tubular steel .
 - 3. Gate Frames and Bracing: Round tubular steel .
- C. Frame Corner Construction: Welded .
- D. Hardware:
 - 1. Hinges: 360-degree inward and outward swing.
 - 2. Latch: Permitting operation from both sides of gate.
 - 3. Padlock and Chain: provided by owner .

2.5 FITTINGS

- A. Provide fittings according to ASTM F 626.
- B. Post Caps: Provide for each post.
 - 1. Provide line post caps with loop to receive tension wire or top rail.
- C. Rail and Brace Ends: For each gate, corner, pull, and end post.
- D. Rail Fittings: Provide the following:
 - 1. Rail Clamps: Line and corner boulevard clamps for connecting bottom rails to posts.
- E. Tension and Brace Bands: Pressed steel .



- F. Tension Bars: , length not less than **2 inches** shorter than full height of chain-link fabric. Provide one bar for each gate and end post, and two for each corner and pull post, unless fabric is integrally woven into post.
- G. Truss Rod Assemblies: Steel, hot-dip galvanized after threading rod and turnbuckle or other means of adjustment.
- H. Tie Wires, Clips, and Fasteners: According to ASTM F 626.
 - 1. Standard Round Wire Ties: For attaching chain-link fabric to posts, rails, and frames, according to the following:
 - a. Hot-Dip Galvanized Steel: 9 Gauge diameter wire ; galvanized coating thickness matching coating thickness of chain-link fence fabric.
- I. Finish:
 - 1. Metallic Coating for Pressed Steel or Cast Iron: Not less than **1.2 oz./sq. ft.** of zinc.

2.6 GROUT AND ANCHORING CEMENT

- A. Nonshrink, Nonmetallic Grout: Factory-packaged, nonstaining, noncorrosive, nongaseous grout complying with ASTM C 1107/C 1107M. Provide grout, recommended in writing by manufacturer, for exterior applications.
- B. Anchoring Cement: Factory-packaged, nonshrink, nonstaining, hydraulic-controlled expansion cement formulation for mixing with water at Project site to create pourable anchoring, patching, and grouting compound. Provide formulation that is resistant to erosion from water exposure without needing protection by a sealer or waterproof coating, and that is recommended in writing by manufacturer for exterior applications.

PART 3 - EXECUTION

3.1 EXAMINATION

- A. Examine areas and conditions, with Installer present, for compliance with requirements for site clearing, earthwork, pavement work, and other conditions affecting performance of the Work.
 - 1. Do not begin installation before final grading is completed unless otherwise permitted by Architect.
- B. Proceed with installation only after unsatisfactory conditions have been corrected.

3.2 PREPARATION

- A. Stake locations of fence lines, gates, and terminal posts. Do not exceed intervals of **500 feet** or line of sight between stakes. Indicate locations of utilities, lawn sprinkler system, underground structures, benchmarks, and property monuments.



3.3 CHAIN-LINK FENCE INSTALLATION

- A. Install chain-link fencing according to ASTM F 567 and more stringent requirements specified.
 - 1. Install fencing on established boundary lines inside property line.
- B. Post Excavation: Drill or hand-excavate holes for posts to diameters and spacings indicated, in firm, undisturbed soil.
- C. Post Setting: Set posts in concrete at indicated spacing into firm, undisturbed soil.
 - 1. Verify that posts are set plumb, aligned, and at correct height and spacing, and hold in position during setting with concrete or mechanical devices.
 - 2. Concrete Fill: Place concrete around posts to dimensions indicated and vibrate or tamp for consolidation. Protect aboveground portion of posts from concrete splatter.
 - a. Concealed Concrete: Place top of concrete **2 inches** below grade to allow covering with surface material.
- D. Terminal Posts: Install terminal end, corner, and gate posts according to ASTM F 567 and terminal pull posts at changes in horizontal or vertical alignment of 15 degrees or more as indicated on Drawings . For runs exceeding **500 feet**, space pull posts an equal distance between corner or end posts.
- E. Line Posts: Space line posts uniformly at **10 feet** o.c.
- F. Post Bracing and Intermediate Rails: Install according to ASTM F 567, maintaining plumb position and alignment of fence posts. Diagonally brace terminal posts to adjacent line posts with truss rods and turnbuckles. Install braces at end and gate posts and at both sides of corner and pull posts.
 - 1. Locate horizontal braces at midheight of fabric **72 inches** or higher, on fences with top rail, and at two-third fabric height on fences without top rail. Install so posts are plumb when diagonal rod is under proper tension.
- G. Tension Wire: Install according to ASTM F 567, maintaining plumb position and alignment of fence posts. Pull wire taut, without sags. Fasten fabric to tension wire with **0.120-inch-** diameter hog rings of same material and finish as fabric wire, spaced a maximum of **24 inches** o.c. Install tension wire in locations indicated before stretching fabric. Provide horizontal tension wire at the following locations:
 - 1. As indicated on Drawings .
- H. Top Rail: Install according to ASTM F 567, maintaining plumb position and alignment of fence posts. Run rail continuously through line post caps, bending to radius for curved runs and terminating into rail end attached to posts or post caps fabricated to receive rail at terminal posts. Provide expansion couplings as recommended in writing by fencing manufacturer.
- I. Intermediate and Bottom Rails: Secure to posts with fittings.



- J. Chain-Link Fabric: Apply fabric to outside of enclosing framework. Leave **1-inch** bottom clearance between finish grade or surface and bottom selvage unless otherwise indicated. Pull fabric taut and tie to posts, rails, and tension wires. Anchor to framework so fabric remains under tension after pulling force is released.
- K. Tension or Stretcher Bars: Thread through fabric and secure to end, corner, pull, and gate posts, with tension bands spaced not more than **15 inches** o.c.
- L. Tie Wires: Use wire of proper length to firmly secure fabric to line posts and rails. Attach wire at one end to chain-link fabric, wrap wire around post a minimum of 180 degrees, and attach other end to chain-link fabric according to ASTM F 626. Bend ends of wire to minimize hazard to individuals and clothing.
 - 1. Maximum Spacing: Tie fabric to line posts at **12 inches** o.c. and to braces at **24 inches** o.c.
- M. Fasteners: Install nuts for tension bands and carriage bolts on the side of fence opposite the fabric side. Peen ends of bolts or score threads to prevent removal of nuts.
- N. Fence-Top Protection: White Line Standard Fence Guard #01923 - Color: Yellow or approved equal
 - 1. Install per manufacturer's recommendations using Fence Ties #03023
 - 2. Provide Product Data Sheet and Sample if using alternate product

3.4 GATE INSTALLATION

- A. Install gates according to manufacturer's written instructions, level, plumb, and secure for full opening without interference. Attach fabric as for fencing. Attach hardware using tamper-resistant or concealed means. Install ground-set items in concrete for anchorage. Adjust hardware for smooth operation.

3.5 ADJUSTING

- A. Gates: Adjust gates to operate smoothly, easily, and quietly, free of binding, warp, excessive deflection, distortion, nonalignment, misplacement, disruption, or malfunction, throughout entire operational range. Confirm that latches and locks engage accurately and securely without forcing or binding.
- B. Lubricate hardware and other moving parts.

END OF SECTION 323113



SECTION 328400 - PLANTING IRRIGATION

PART 1 - GENERAL

1.1 RELATED DOCUMENTS

- A. Drawings and general provisions of the Contract, including General and Supplementary Conditions and Division 01 Specification Sections, apply to this Section.

1.2 SUMMARY

- A. Section Includes:

1. Piping.
2. Encasement for piping.
3. Pressure-reducing valves.
4. Automatic control valves.
5. Automatic drain valves.
6. Transition fittings.
7. Miscellaneous piping specialties.
8. Quick couplers.
9. Drip irrigation specialties.
10. Controllers.
11. Boxes for automatic control valves.

- B. Sprinklers.

- C. Related Sections:

1. 312316.13 - Trenching
2. Section 220519 "Meters and Gages for Plumbing Piping" for water metering requirements.
3. Section 230923.14 "Flow Instruments" for water metering equipment.

1.3 DEFINITIONS

- A. Circuit Piping: Downstream from control valves to sprinklers, specialties, and drain valves. Piping is under pressure during flow.
- B. Drain Piping: Downstream from circuit-piping drain valves. Piping is not under pressure.
- C. ET Controllers: EvapoTranspiration Controllers. Irrigation controllers which use some method of weather-based adjustment of irrigation. These adjusting methods include use of historical monthly averages of ET; broadcasting of ET measurements; or use of on-site sensors to track ET.
- D. Main Piping: Downstream from point of connection to water distribution piping to, and including, control valves. Piping is under water-distribution-system pressure.



- E. Low Voltage: As defined in NFPA 70 for circuits and equipment operating at less than 50 V or for remote-control, signaling power-limited circuits.

1.4 PERFORMANCE REQUIREMENTS

- A. Irrigation zone control shall be automatic operation with controller and automatic control manual operation with manual valves.
- B. Location of Sprinklers and Specialties: Design location is approximate. Make minor adjustments necessary to avoid plantings and obstructions such as signs and light standards. Maintain 100 percent irrigation coverage of areas indicated.
- C. Minimum Working Pressures: The following are minimum pressure requirements for piping, valves, and specialties unless otherwise indicated:
 - 1. Irrigation Main Piping: 200 PSI.
 - 2. Circuit Piping: 150 PSI.

1.5 ACTION SUBMITTALS

- A. Product Data: For each type of product indicated. Include rated capacities, operating characteristics, and furnished specialties and accessories.
- B. Wiring Diagrams: For power, signal, and control wiring.

1.6 INFORMATIONAL SUBMITTALS

- A. Coordination Drawings: Irrigation systems, drawn to scale, on which components are shown and coordinated with each other, using input from Installers of the items involved. Also include adjustments necessary to avoid plantings and obstructions such as signs and light standards.
- B. Qualification Data: For qualified Installer.
- C. Zoning Chart: Show each irrigation zone and its control valve.
- D. Controller Timing Schedule: Indicate timing settings for each automatic controller zone.

1.7 CLOSEOUT SUBMITTALS

- A. Operation and Maintenance Data: For sprinklers controllers and automatic control valves to include in operation and maintenance manuals.

1.8 MAINTENANCE MATERIAL SUBMITTALS

- A. Furnish extra materials that match products installed and that are packaged with protective covering for storage and identified with labels describing contents.



1. Spray Sprinklers: 5 units.

1.9 QUALITY ASSURANCE

- A. Installer Qualifications: An employer of workers that include a Licensed Master Irrigator .
- B. Electrical Components, Devices, and Accessories: Listed and labeled as defined in NFPA 70, by a qualified testing agency, and marked for intended location and application.

1.10 DELIVERY, STORAGE, AND HANDLING

- A. Deliver piping with factory-applied end caps. Maintain end caps through shipping, storage, and handling to prevent -end damage and to prevent entrance of dirt, debris, and moisture.
- B. Store plastic piping protected from direct sunlight. Support to prevent sagging and bending.

1.11 PROJECT CONDITIONS

- A. Interruption of Existing Water Service: Do not interrupt water service to facilities occupied by Owner or others unless permitted under the following conditions and then only after arranging to provide temporary water service according to requirements indicated:
 1. Notify Construction Manager no fewer than two days in advance of proposed interruption of water service.
 2. Do not proceed with interruption of water service without Owner's written permission.

PART 2 - PRODUCTS

2.1 PIPES, TUBES, AND FITTINGS

- A. Comply with requirements in the piping schedule for applications of pipe, tube, and fitting materials, and for joining methods for specific services, service locations, and pipe sizes.
- B. Soft Copper Tube: , water tube, annealed temper.
 1. Copper Pressure Fittings: ASME B16.18, cast-copper-alloy or ASME B16.22, wrought-copper solder-joint fittings. Furnish wrought-copper fittings if indicated.
 2. Bronze Flanges: ASME B16.24, Class 150, with solder-joint end.
 3. Copper Unions: MSS SP-123, cast-copper-alloy, hexagonal-stock body, with ball-and-socket, metal-to-metal seating surfaces and solder-joint or threaded ends.
- C. PVC Pipe: ASTM D 1785, PVC 1120 compound, Schedule 40 .
 1. PVC Socket Fittings: ASTM D 2466, Schedules 40 and 80.
 2. PVC Threaded Fittings: ASTM D 2464, Schedule 80.



3. PVC Socket Unions: Construction similar to MSS SP-107, except both headpiece and tailpiece shall be PVC with socket ends.

D. PVC Pipe, Pressure Rated: ASTM D 2241, PVC 1120 compound, SDR 21 and SDR 26.

1. PVC Socket Fittings: ASTM D 2467, Schedule 80.
2. PVC Socket Unions: Construction similar to MSS SP-107, except both headpiece and tailpiece shall be PVC with socket or threaded ends.

2.2 PIPING JOINING MATERIALS

- A. Pipe-Flange Gasket Materials: AWWA C110, rubber, flat face, **1/8 inch** thick unless otherwise indicated; full-face or ring type unless otherwise indicated.
- B. Brazing Filler Metals: AWS A5.8/A5.8M, BCuP Series, copper-phosphorus alloys for general-duty brazing unless otherwise indicated.
- C. Solder Filler Metals: ASTM B 32, lead-free alloys. Include water-flushable flux according to ASTM B 813.
- D. Solvent Cements for Joining PVC Piping: ASTM D 2564. Include primer according to ASTM F 656.
- E. Plastic, Pipe-Flange Gasket, Bolts, and Nuts: Type and material recommended by piping system manufacturer unless otherwise indicated.

2.3 MANUAL VALVES

A. Bronze Ball Valves:

1. **Manufacturers:** Subject to compliance with requirements, undefined:
 - a. Apollo Flow Controls; Conbraco Industries, Inc.
 - b. NIBCO INC.
 - c. WATTS.
 - d. Zurn Industries, LLC.
 - e. Or Approved Equal
2. Description:
 - a. Standard: MSS SP-110.
 - b. SWP Rating: **150 psig.**
 - c. CWP Rating: **600 psig.**
 - d. Body Design: Two piece.
 - e. Body Material: Bronze.
 - f. Ends: Threaded or solder joint if indicated.
 - g. Seats: PTFE or TFE.
 - h. Stem: Bronze.
 - i. Ball: Chrome-plated brass.
 - j. Port: Full or regular, but not reduced.



B. Plastic Ball Valves:

1. **Manufacturers:** Subject to compliance with requirements, undefined:
 - a. NIBCO INC.
 - b. Spears Manufacturing Company.
 - c. WATTS.
 - d. Or Approved Equal
2. Description:
 - a. Standard: MSS SP-122.
 - b. Pressure Rating: **125 psig** minimum .
 - c. Body Material: PVC.
 - d. Type: Union.
 - e. End Connections: Socket or threaded.
 - f. Port: Full.

C. Iron Gate Valves, NRS:

1. **Manufacturers:** Subject to compliance with requirements, undefined:
 - a. NIBCO INC.
 - b. WATTS.
 - c. Or Approved Equal
2. Description:
 - a. Standard: MSS SP-70, Type I.
 - b. CWP Rating: **200 psig**.
 - c. Body Material: ASTM A 126, gray iron with bolted bonnet.
 - d. Ends: Flanged.
 - e. Trim: All bronze.
 - f. Disc: Solid wedge.
 - g. Packing and Gasket: Asbestos free.

2.4 PRESSURE-REDUCING VALVES

A. Water Regulators:

1. **Manufacturers:** Subject to compliance with requirements, undefined:
 - a. Apollo Flow Controls; Conbraco Industries, Inc.
 - b. WATTS.
 - c. Or Approved Equal
2. Description:
 - a. Standard: ASSE 1003.
 - b. Body Material: Bronze for **NPS 2** and smaller; cast iron for **NPS 2-1/2** and **NPS 3**.
 - c. Pressure Rating: Initial pressure of **150 psig**.
 - d. End Connections: Threaded for **NPS 2** and smaller; flanged for **NPS 2-1/2** and **NPS 3**.
3. Capacities and Characteristics:
 - a. Size: [**NPS**].
 - b. Design Flow Rate: [**gpm**].
 - c. Design Inlet Pressure: [**psig**].
 - d. Design Outlet Pressure Setting: [**psig**].



B. Water Control Valves:

1. **Manufacturers:** Subject to compliance with requirements, provide products by one of the following:
 - a. WATTS.
 - b. Zurn Industries, LLC.
 - c. Or Approved Equal
2. Description: Pilot-operation, diaphragm-type, single-seated main water control valve. Include small pilot control valve, restrictor device, specialty fittings, and sensor piping.
 - a. Main Valve Body: Cast- or ductile-iron body with AWWA C550 or FDA-approved, interior epoxy coating; or stainless-steel body.
 - b. Pattern: Angle -valve design.
 - c. Trim: Stainless steel.
 - d. Pressure Rating: Initial pressure of **150 psig** minimum.
 - e. End Connections: Threaded for **NPS 2** and smaller; Gasket Joint for **NPS 2-1/2** and larger.

2.5 AUTOMATIC CONTROL VALVES

A. Plastic, Automatic Control Valves:

1. **Manufacturers:** Subject to compliance with requirements, provide products by one of the following:
 - a. Hunter Industries Incorporated.
 - b. Rain Bird PGA or Approved Equal
2. Description: Molded-plastic body, normally closed, diaphragm type with manual-flow adjustment, and operated by 24-V ac solenoid.

2.6 AUTOMATIC DRAIN VALVES

- A. Description: Spring-loaded-ball type of corrosion-resistant construction and designed to open for drainage if line pressure drops below **2-1/2 to 3 psig**.

2.7 TRANSITION FITTINGS

- A. General Requirements: Same size as, and with pressure rating at least equal to and with ends compatible with, piping to be joined.

B. Transition Couplings:

1. **Manufacturers:** Subject to compliance with requirements, provide products by one of the following:
 - a. Ford Meter Box Company, Inc. (The).
 - b. JCM Industries, Inc.
 - c. Smith-Blair, Inc.
 - d. Or Approved Equal
2. Description: AWWA C219, metal sleeve-type coupling for underground pressure piping.



2.8 MISCELLANEOUS PIPING SPECIALTIES

- A. Water Hammer Arresters: ASSE 1010 or PDI WH 201, with bellows or piston-type pressurized cushioning chamber and in sizes complying with PDI WH 201, Sizes A to F.
- B. Pressure Gages: ASME B40.1. Include **4-1/2-inch-** diameter dial, dial range of two times system operating pressure, and bottom outlet.

2.9 SPRINKLERS

- A. General Requirements: Designed for uniform coverage over entire spray area indicated at available water pressure.
- B. Plastic, Pop-up, Gear-Drive Rotary Sprinklers:
 - 1. **Manufacturers:** Subject to compliance with requirements, provide products by one of the following:
 - a. Hunter Industries Incorporated.
 - b. Rain Bird Corporation.
 - c. Or Approved Equal
 - 2. Description:
 - a. Body Material: ABS.
 - b. Nozzle: ABS .
 - c. Retraction Spring: Stainless steel.
 - d. Internal Parts: Corrosion resistant.
- C. Metal, Pop-up, Impact-Drive Rotary Sprinklers:
 - 1. **Manufacturers:** Subject to compliance with requirements, provide products by the following :
 - a. Rain Bird.
 - b. Or Approved Equal
 - 2. Description:
 - a. Case: Brass.
 - b. Body Material: Brass.
 - c. Pop-up Height: **4 inches** aboveground to nozzle.
 - d. Sprinkler Construction: Brass and other corrosion-resistant metals.

2.10 QUICK COUPLERS

- A. **Manufacturers:** Subject to compliance with requirements, provide products by the following:
 - 1. Rain Bird Corporation.
 - 2. Or Approved Equal
- B. Description: Factory-fabricated, bronze or brass, two-piece assembly. Include coupler water-seal valve; removable upper body with spring-loaded or weighted, rubber-covered cap; hose swivel with ASME B1.20.7, 3/4-11.5NH threads for garden hose on outlet; and operating key.



1. Locking-Top Option: Vandal-resistant locking feature. Include one matching key(s).

2.11 CONTROLLERS

- A. Manufacturers: Subject to compliance with requirements, provide products by one of the following:

1. Hunter Industries Incorporated.
2. Rain Bird Corporation.
3. Or Approved Equal

- B. Description:

1. Controller Stations for Automatic Control Valves: Each station is variable from approximately 5 to 60 minutes. Include switch for manual or automatic operation of each station.
2. Exterior Control Enclosures: NEMA 250, Type 4, weatherproof, with locking cover and two matching keys; include provision for grounding.
 - a. Body Material: Enameled-steel sheet metal .
 - b. Mounting: Freestanding type for concrete base .
3. Interior Control Enclosures: NEMA 250, Type 12, dripproof, with locking cover and two matching keys.
 - a. Body Material: Molded plastic.
 - b. Mounting: Surface type for wall.
4. Control Transformer: 24-V secondary, with primary fuse.
5. Timing Device: Adjustable, 24-hour, 14-day clock, with automatic operations to skip operation any day in timer period, to operate every other day, or to operate two or more times daily.
 - a. Manual or Semiautomatic Operation: Allows this mode without disturbing preset automatic operation.
 - b. Nickel-Cadmium Battery and Trickle Charger: Automatically powers timing device during power outages.
 - c. Surge Protection: Metal-oxide-varistor type on each station and primary power.
6. Moisture Sensor: Adjustable from one to seven days, to shut off water flow during rain.
7. Smart Controllers: Use ET, tested in accordance with IA SWAT Climatological Based Controllers 8th Draft Testing Protocol and compliant with ASHRAE Standard 189.1.
8. Wiring: UL 493, Type UF multiconductor, with solid-copper conductors; insulated cable; suitable for direct burial.
 - a. Feeder-Circuit Cables: No. 12 AWG minimum, between building and controllers.
 - b. Low-Voltage, Branch-Circuit Cables: No. 14 AWG minimum, between controllers and automatic control valves; color-coded different from feeder-circuit-cable jacket color; with jackets of different colors for multiple-cable installation in same trench.
 - c. Splicing Materials: Manufacturer's packaged kit consisting of insulating, spring-type connector or crimped joint and epoxy resin moisture seal; suitable for direct burial.
9. Concrete Base: Reinforced precast concrete not less than **36 by 24 by 4 inches** thick, and **6 inches** greater in each direction than overall dimensions of controller. Include opening for wiring.



2.12 BOXES FOR AUTOMATIC CONTROL VALVES

A. Plastic Boxes:

1. **Manufacturers:** Subject to compliance with requirements, provide products by one of the following:
 - a. Ametec.
 - b. Armorcast Products Company.
 - c. Carson.
 - d. Or Approved Equal
2. Description: Box and cover, with open bottom and openings for piping; designed for installing flush with grade.
 - a. Size: As required for valves and service.
 - b. Shape: Rectangular.
 - c. Sidewall Material: PE, ABS, or FRP .
 - d. Cover Material: PE, ABS, or FRP .
 - 1) Lettering: " IRRIGATION ."

- B. Drainage Backfill: Cleaned gravel or crushed stone, graded from **3/4 inch** minimum to **3 inches** maximum.

PART 3 - EXECUTION

3.1 EARTHWORK

- A. Excavating, trenching, and backfilling are specified in Section 312000 "Earth Moving."
- B. Drain Pockets: Excavate to sizes indicated. Backfill with cleaned gravel or crushed stone, graded from **3/4 to 3 inches** , to **12 inches** below grade. Cover gravel or crushed stone with sheet of asphalt-saturated felt and backfill remainder with excavated material.
- C. Provide minimum cover over top of underground piping according to the following:
1. Irrigation Main Piping: Minimum depth of 18 inches below finished grade, or not less than
 2. Circuit Piping: **12 inches** .
 3. Drain Piping: **12 inches** .
 4. Sleeves: 18 inches

3.2 PREPARATION

- A. Set stakes to identify locations of proposed irrigation system. Obtain Architect's approval before excavation.

3.3 PIPING INSTALLATION

- A. Location and Arrangement: Drawings indicate location and arrangement of piping systems. Install piping as indicated unless deviations are approved on Coordination Drawings.



- B. Install piping at minimum uniform slope of 0.5 percent down toward drain valves.
- C. Install piping free of sags and bends.
- D. Install groups of pipes parallel to each other, spaced to permit valve servicing.
- E. Install fittings for changes in direction and branch connections.
- F. Install unions adjacent to valves and to final connections to other components with **NPS 2** or smaller pipe connection.
- G. Install flanges adjacent to valves and to final connections to other components with **NPS 2-1/2** or larger pipe connection.
- H. Install underground thermoplastic piping according to ASTM D 2774.
- I. Install expansion loops in control-valve boxes for plastic piping.
- J. Lay piping on solid subbase, uniformly sloped without humps or depressions.
- K. Install ductile-iron piping according to AWWA C600.
- L. Install PVC piping in dry weather when temperature is above **40 deg F**. Allow joints to cure at least 24 hours at temperatures above **40 deg F** before testing.
- M. Install water regulators with shutoff valve and strainer on inlet and pressure gage on outlet. Install shutoff valve on outlet. Install aboveground or in control-valve boxes.
- N. Water Hammer Arresters: Install between connection to building main and circuit valves aboveground or in control-valve boxes.
- O. Install piping in sleeves under parking lots, roadways, and sidewalks.
- P. Install sleeves made of Schedule 40 PVC pipe and socket fittings, and solvent-cemented joints.
- Q. Install transition fittings for plastic-to-metal pipe connections according to the following:
 - 1. Underground Piping:
 - a. **NPS 1-1/2** and Smaller: Plastic-to-metal transition fittings.
 - b. **NPS 2** and Larger: AWWA transition couplings.
 - 2. Aboveground Piping:
 - a. **NPS 2** and Smaller: Plastic-to-metal transition fittings .
 - b. **NPS 2** and Larger: Use dielectric flange kits with one plastic flange.

3.4 JOINT CONSTRUCTION

- A. Ream ends of pipes and tubes and remove burrs. Bevel plain ends of steel pipe.
- B. Remove scale, slag, dirt, and debris from inside and outside of pipe and fittings before assembly.



- C. Threaded Joints: Thread pipe with tapered pipe threads according to ASME B1.20.1. Cut threads full and clean using sharp dies. Ream threaded pipe ends to remove burrs and restore full ID. Join pipe fittings and valves as follows:
 - 1. Apply appropriate tape or thread compound to external pipe threads unless dry seal threading is specified.
 - 2. Damaged Threads: Do not use pipe or pipe fittings with threads that are corroded or damaged. Do not use pipe sections that have cracked or open welds.
- D. Flanged Joints: Select rubber gasket material, size, type, and thickness for service application. Install gasket concentrically positioned. Use suitable lubricants on bolt threads.
- E. Copper-Tubing Brazed Joints: Construct joints according to CDA's "Copper Tube Handbook," using copper-phosphorus brazing filler metal.
- F. Copper-Tubing Soldered Joints: Apply ASTM B 813 water-flushable flux to tube end unless otherwise indicated. Construct joints according to ASTM B 828 or CDA's "Copper Tube Handbook," using lead-free solder alloy (0.20 percent maximum lead content) complying with ASTM B 32.
- G. PVC Piping Solvent-Cemented Joints: Clean and dry joining surfaces. Join pipe and fittings according to the following:
 - 1. Comply with ASTM F 402 for safe-handling practice of cleaners, primers, and solvent cements.
 - 2. PVC Pressure Piping: Join schedule number, ASTM D 1785, PVC pipe and PVC socket fittings according to ASTM D 2672. Join other-than-schedule-number PVC pipe and socket fittings according to ASTM D 2855.
 - 3. PVC Nonpressure Piping: Join according to ASTM D 2855.

3.5 VALVE INSTALLATION

- A. Underground Curb Valves: Install in curb-valve casings with tops flush with grade.
- B. Underground Iron Gate Valves, Resilient Seat: Comply with AWWA C600 and AWWA M44. Install in valve casing with top flush with grade.
 - 1. Install valves and PVC pipe with restrained, gasketed joints.
- C. Aboveground Valves: Install as components of connected piping system.
- D. Pressure-Reducing Valves: Install in boxes for automatic control valves or aboveground between shutoff valves.
- E. Throttling Valves: Install in underground piping in boxes for automatic control valves.
- F. Drain Valves: Install in underground piping in boxes for automatic control valves.



3.6 SPRINKLER INSTALLATION

- A. Install sprinklers after hydrostatic test is completed.
- B. Install sprinklers at manufacturer's recommended heights.
- C. Locate part-circle sprinklers to maintain a minimum distance of **4 inches** from walls and **2 inches** from other boundaries unless otherwise indicated.

3.7 AUTOMATIC IRRIGATION-CONTROL SYSTEM INSTALLATION

- A. Equipment Mounting: Install interior controllers on wall.
 - 1. Place and secure anchorage devices. Use setting drawings, templates, diagrams, instructions, and directions furnished with items to be embedded.
 - 2. Install anchor bolts to elevations required for proper attachment to supported equipment.
- B. Equipment Mounting: Install exterior freestanding controllers on precast concrete bases.
 - 1. Place and secure anchorage devices. Use setting drawings, templates, diagrams, instructions, and directions furnished with items to be embedded.
 - 2. Install anchor bolts to elevations required for proper attachment to supported equipment.
- C. Install control cable in same trench as irrigation piping and at least **2 inches** below or beside piping. Provide conductors of size not smaller than recommended by controller manufacturer. Install cable in separate sleeve under paved areas.

3.8 CONNECTIONS

- A. Comply with requirements for piping specified in Section 221113 "Facility Water Distribution Piping" for water supply from exterior water service piping, water meters, protective enclosures, and backflow preventers. Drawings indicate general arrangement of piping, fittings, and specialties.
- B. Install piping adjacent to equipment, valves, and devices to allow service and maintenance.
- C. Connect wiring between controllers and automatic control valves.

3.9 IDENTIFICATION

- A. Identify system components. Comply with requirements for identification specified in Section 220553 "Identification for Plumbing Piping and Equipment."
- B. Equipment Nameplates and Signs: Install engraved plastic-laminate equipment nameplates and signs on each automatic controller.



1. Text: In addition to identifying unit, distinguish between multiple units, inform operator of operational requirements, indicate safety and emergency precautions, and warn of hazards and improper operations.
- C. Warning Tapes: Arrange for installation of continuous, underground, detectable warning tapes over underground piping during backfilling of trenches. See Section 312000 "Earth Moving" for warning tapes.

3.10 FIELD QUALITY CONTROL

- A. Perform tests and inspections.
 1. Manufacturer's Field Service: Engage a factory-authorized service representative to inspect components, assemblies, and equipment installations, including connections, and to assist in testing.
- B. Tests and Inspections:
 1. Leak Test: After installation, charge system and test for leaks. Repair leaks and retest until no leaks exist.
 2. Operational Test: After electrical circuitry has been energized, operate controllers and automatic control valves to confirm proper system operation.
 3. Test and adjust controls and safeties. Replace damaged and malfunctioning controls and equipment.
- C. Any irrigation product will be considered defective if it does not pass tests and inspections.
- D. Prepare test and inspection reports.

3.11 STARTUP SERVICE AND WINTERIZATION

- A. Perform startup service.
 1. Complete installation and startup checks according to manufacturer's written instructions.
 2. Verify that controllers are installed and connected according to the Contract Documents.
 3. Verify that electrical wiring installation complies with manufacturer's submittal.
- B. Perform winterization Service
 1. Complete (1) system shut-down with training

3.12 ADJUSTING

- A. Adjust settings of controllers.
- B. Adjust automatic control valves to provide flow rate at rated operating pressure required for each sprinkler circuit.



- C. Adjust sprinklers and devices, except those intended to be mounted aboveground, so they will be flush with, or not more than 1/4 inch above, finish grade.

3.13 CLEANING

- A. Flush dirt and debris from piping before installing sprinklers and other devices.

3.14 DEMONSTRATION

- A. Train Owner's maintenance personnel to adjust, operate, and maintain automatic control valves and controllers.

3.15 PIPING SCHEDULE

- A. Install components having pressure rating equal to or greater than system operating pressure.
- B. Piping in control-valve boxes and aboveground may be joined with flanges or unions instead of joints indicated.
- C. Underground irrigation main piping, 2-1/2" , shall be one of the following:
 - 1. Schedule 40, PVC Gasket Joint pipe and socket fittings
 - 2. PVC Class 200 SDR 21 - 2.5" Dia.
- D. Circuit piping, 1 inch to 2 inch , shall be one of the following:
 - 1. Schedule 40, PVC pipe and socket fittings; and solvent-cemented joints.
 - 2. SDR 26, PVC, pressure-rated pipe; Schedule 40, PVC socket fittings; and solvent-cemented joints.
- E. Underground Branches and Offsets at Sprinklers and Devices: Schedule 80, PVC pipe; threaded PVC fittings; and threaded joints.
 - 1. Option: Plastic swing-joint assemblies, with offsets for flexible joints, manufactured for this application.
- F. Risers to Aboveground Sprinklers and Specialties: hard copper tube, wrought-copper fittings, and soldered joints.
- G. Risers to Aboveground Sprinklers and Specialties: Schedule 80, PVC pipe and socket fittings; and solvent-cemented joints.
- H. Drain piping shall be one of the following:
 - 1. SDR 21, 26, or 32.5, PVC, pressure-rated pipe; Schedule 40, PVC socket fittings; and solvent-cemented joints.



3.16 VALVE SCHEDULE

A. Underground, Shutoff-Duty Valves: Use the following:

1. **NPS 2** and Smaller: Curb valve, curb-valve casing, and shutoff rod.
2. **NPS 3** and Larger: Iron gate valve, resilient seated; iron gate valve casing; and operating wrench(es).

B. Drain Valves:

1. **NPS 1/2 and NPS 3/4**: Plastic ball valve.
2. **NPS 1 to NPS 2**: Plastic ball valve.

END OF SECTION 328400



SECTION 329119 - LANDSCAPE GRADING

PART 1 - GENERAL

1.1 SUMMARY

- A. Section Includes:
 - 1. Final grade topsoil for finish landscaping.
- B. Related Sections:
 - 1. 312316.13 - Trenching
 - 2. 329200 - Turf and Grasses

1.2 UNIT PRICE - MEASUREMENT AND PAYMENT

- A. Topsoil:
 - 1. Basis of Measurement: By Cubic Yard (CY) .
 - 2. Basis of Payment: Includes excavating existing topsoil, supplying topsoil materials, stockpiling, preparing and scarifying substrate surface, placing where required, and rolling.

1.3 SUBMITTALS

- A. Section 013300 - Submittal Procedures: Submittal procedures
- B. Samples: Submit, in air-tight containers, 1 cup sample of loam to testing laboratory.
- C. Materials Source: Submit name of imported materials source.

1.4 QUALITY ASSURANCE

- A. Furnish each topsoil material from single source throughout the Work.
- B. Perform Work in accordance with RIDOT Standard Specifications for Road & Bridge Construction, latest edition .

PART 2 - PRODUCTS

2.1 MATERIAL

- A. Topsoil: Fill Type S2 as specified in Section 329300.



PART 3 - EXECUTION

3.1 EXAMINATION

- A. Section 013000 - Administrative Requirements: Verification of existing conditions before starting work.
- B. Verify substrate base has been contoured and compacted.

3.2 PREPARATION

- A. Protect landscaping and other features remaining as final Work.
- B. Protect existing structures, sidewalks, utilities, paving, and curbs.

3.3 SUBSTRATE PREPARATION

- A. Eliminate uneven areas and low spots.
- B. Remove debris, loose roots, branches, stones, in excess of **1/2 inch** in size. Remove contaminated subsoil.
- C. Scarify surface to depth of **3 inches** where topsoil is scheduled. Scarify in areas where equipment used for hauling and spreading topsoil has compacted subsoil.

3.4 PLACING TOPSOIL

- A. Place topsoil in areas where seeding, is required to thickness as scheduled. Place topsoil during dry weather.
- B. Fine grade topsoil to eliminate rough or low areas. Maintain profiles and contour of subgrade.
- C. Remove roots, weeds, rocks, and foreign material while spreading.
- D. Manually spread topsoil close to plant material, and path to prevent damage.
- E. Roll placed topsoil.
- F. Remove surplus subsoil and topsoil from site.
- G. Leave stockpile area and site clean and raked, ready to receive landscaping.

3.5 TOLERANCES

- A. Section 014000 - Quality Requirements: Tolerances.



- B. Top of Topsoil: Plus or minus **1/2 inch**.

3.6 PROTECTION OF INSTALLED WORK

- A. Section 017000 - Execution and Closeout Requirements: Requirements for protecting finished Work.
- B. Prohibit construction traffic over topsoil.

3.7 SCHEDULES

- A. Compacted topsoil thicknesses:
 - 1. Seeded Grass: **6 inches**.

END OF SECTION 329119



SECTION 329200 - TURF AND GRASSES

PART 1 - GENERAL

1.1 RELATED DOCUMENTS

- A. Drawings and general provisions of the Contract, including General and Supplementary Conditions and Division 01 Specification Sections, apply to this Section.

1.2 SUMMARY

- A. Section Includes:

1. Seeding.
2. Hydroseeding.
3. Turf renovation.

- B. Related Requirements:

1. Section 329300 "Plants" for trees, shrubs, ground covers, and other plants as well as border edgings and mow strips.

1.3 DEFINITIONS

- A. Finish Grade: Elevation of finished surface of planting soil.
- B. Pesticide: A substance or mixture intended for preventing, destroying, repelling, or mitigating a pest. Pesticides include insecticides, miticides, herbicides, fungicides, rodenticides, and molluscicides. They also include substances or mixtures intended for use as a plant regulator, defoliant, or desiccant.
- C. Pests: Living organisms that occur where they are not desired or that cause damage to plants, animals, or people. Pests include insects, mites, grubs, mollusks (snails and slugs), rodents (gophers, moles, and mice), unwanted plants (weeds), fungi, bacteria, and viruses.
- D. Planting Soil: Existing, on-site soil; imported soil; or manufactured soil that has been modified with soil amendments and perhaps fertilizers to produce a soil mixture best for plant growth. See Section 329113 "Soil Preparation" and drawing designations for planting soils.
- E. Subgrade: The surface or elevation of subsoil remaining after excavation is complete, or the top surface of a fill or backfill before planting soil is placed.

1.4 PREINSTALLATION MEETINGS

- A. Preinstallation Conference: Conduct conference at Project site .



1.5 INFORMATIONAL SUBMITTALS

- A. Certification of Grass Seed: From seed vendor for each grass-seed monostand or mixture, stating the botanical and common name, percentage by weight of each species and variety, and percentage of purity, germination, and weed seed. Include the year of production and date of packaging.
- B. Product Certificates: For fertilizers, from manufacturer.

1.6 CLOSEOUT SUBMITTALS

- A. Maintenance Data: Recommended procedures to be established by Owner for maintenance of turf during a calendar year. Submit before expiration of required maintenance periods.

1.7 QUALITY ASSURANCE

- A. Installer Qualifications: A qualified landscape installer whose work has resulted in successful turf establishment.
 - 1. Professional Membership: Installer shall be a member in good standing of either the National Association of Landscape Professionals or AmericanHort.
 - 2. Experience: Five years' experience in turf installation in addition to requirements in Section 014000 "Quality Requirements."
 - 3. Installer's Field Supervision: Require Installer to maintain an experienced full-time supervisor on Project site when work is in progress.
 - 4. Personnel Certifications: Installer's field supervisor shall have certification in one of the following categories from the National Association of Landscape Professionals:
 - a. Landscape Industry Certified Technician - Exterior.
 - b. Landscape Industry Certified Lawn Care Manager.
 - c. Landscape Industry Certified Lawn Care Technician.
 - 5. Pesticide Applicator: State licensed, commercial.

1.8 DELIVERY, STORAGE, AND HANDLING

- A. Seed and Other Packaged Materials: Deliver packaged materials in original, unopened containers showing weight, certified analysis, name and address of manufacturer, and indication of compliance with state and Federal laws, as applicable.
- B. Bulk Materials:
 - 1. Do not dump or store bulk materials near structures, utilities, walkways and pavements, or on existing turf areas or plants.
 - 2. Accompany each delivery of bulk materials with appropriate certificates.



1.9 FIELD CONDITIONS

- A. Planting Restrictions: Plant during one of the following periods. Coordinate planting periods with initial maintenance periods to provide required maintenance from date of Substantial Completion .
 - 1. Spring Planting: April 15 - May 15 .
- B. Weather Limitations: Proceed with planting only when existing and forecasted weather conditions permit planting to be performed when beneficial and optimum results may be obtained. Apply products during favorable weather conditions according to manufacturer's written instructions.

PART 2 - PRODUCTS

2.1 SEED

- A. Grass Seed: Fresh, clean, dry, new-crop seed complying with AOSA's "Rules for Testing Seeds" for purity and germination tolerances.
- B. Seed Species:
 - 1. Quality: Seed of grass species as listed below for solar exposure, with not less than 85 percent germination, not less than 95 percent pure seed, and not more than 0.5 percent weed seed:
- C. Description: Sport Field Mix for Irrigated Lawn
 - 1. Improved Kentucky Blue Grass: 40% percent.
 - 2. Chewing Fescue: 25% percent.
 - 3. 3way Perennial Rye: 30% percent
 - 4. Micro Clover: 5% percent or approved equal
- D. Products may be acquired from the following source (or approved equal) :
 - 1. Allen's Seed Store : 693 S County Trail Exeter, RI 02822 Phone: 401 294 2722

2.2 FERTILIZERS

- A. Commercial Fertilizer: Commercial-grade complete fertilizer of neutral character, consisting of fast- and slow-release nitrogen, 50 percent derived from natural organic sources of urea formaldehyde, phosphorous, and potassium in the following composition:
 - 1. Composition: fertilizer to have a ratio of 18 Nitrogen (N) - 24 Phosphorous (P) - 12 Potassium (K)
- B. Slow-Release Fertilizer: Granular or pelleted fertilizer consisting of 50 percent water-insoluble nitrogen, phosphorus, and potassium in the following composition:



1. Composition: fertilizer to have a ratio of 18 Nitrogen (N) - 24 Phosphorous (P) - 12 Potassium (K)

PART 3 - EXECUTION

3.1 EXAMINATION

- A. Examine areas to be planted for compliance with requirements and other conditions affecting installation and performance of the Work.
 1. Verify that no foreign or deleterious material or liquid such as paint, paint washout, concrete slurry, concrete layers or chunks, cement, plaster, oils, gasoline, diesel fuel, paint thinner, turpentine, tar, roofing compound, or acid has been deposited in soil within a planting area.
 2. Suspend planting operations during periods of excessive soil moisture until the moisture content reaches acceptable levels to attain the required results.
 3. Uniformly moisten excessively dry soil that is not workable or which is dusty.
- B. Proceed with installation only after unsatisfactory conditions have been corrected.
- C. If contamination by foreign or deleterious material or liquid is present in soil within a planting area, remove the soil and contamination as directed by Architect and replace with new planting soil.

3.2 PREPARATION

- A. Protect structures; utilities; sidewalks; pavements; and other facilities, trees, shrubs, and plantings from damage caused by planting operations.
 1. Protect adjacent and adjoining areas from hydroseeding and hydromulching overspray.
 2. Protect grade stakes set by others until directed to remove them.

3.3 TURF AREA PREPARATION

- A. General: Prepare planting area for soil placement and mix planting soil according to Section 329113 "Soil Preparation."
- B. Placing Planting Soil: Place and mix planting soil in place over exposed subgrade .
- C. Moistened prepared area before planting if soil is dry. Water thoroughly and allow surface to dry before planting. Do not create muddy soil.
- D. Before planting, obtain Architect's acceptance of finish grading; restore planting areas if eroded or otherwise disturbed after finish grading.



3.4 SEEDING

- A. Sow seed with spreader or seeding machine. Do not broadcast or drop seed when wind velocity exceeds **5 mph** .
 - 1. Evenly distribute seed by sowing equal quantities in two directions at right angles to each other.
 - 2. Do not use wet seed or seed that is moldy or otherwise damaged.
 - 3. Do not seed against existing trees. Limit extent of seed to outside edge of planting saucer.
- B. Sow seed at a total rate of **5 to 8 lb/1000 sq. ft.** .
- C. Rake seed lightly into top **1/8 inch** of soil, roll lightly, and water with fine spray.

3.5 HYDROSEEDING

- A. Hydroseeding: Mix specified seed, fertilizer , and fiber mulch in water, using equipment specifically designed for hydroseed application. Continue mixing until uniformly blended into homogeneous slurry suitable for hydraulic application.
 - 1. Mix slurry with fiber-mulch manufacturer's recommended tackifier.
 - 2. Spray-apply slurry uniformly to all areas to be seeded in a one-step process. Apply slurry at a rate so that mulch component is deposited at not less than **1500-lb/acre** dry weight, and seed component is deposited at not less than the specified seed-sowing rate.

3.6 TURF RENOVATION

- A. Renovate turf damaged by Contractor's operations, such as storage of materials or equipment and movement of vehicles.
 - 1. Reestablish turf where settlement or washouts occur or where minor regrading is required.
 - 2. Install new planting soil as required.
- B. Remove sod and vegetation from diseased or unsatisfactory turf areas; do not bury in soil.
- C. Remove topsoil containing foreign materials, such as oil drippings, fuel spills, stones, gravel, and other construction materials resulting from Contractor's operations, and replace with new planting soil.
- D. Mow, dethatch, core aerate, and rake existing turf.
- E. Remove weeds before seeding. Where weeds are extensive, apply selective herbicides as required. Do not use pre-emergence herbicides.
- F. Remove waste and foreign materials, including weeds, soil cores, grass, vegetation, and turf, and legally dispose of them off Owner's property.
- G. Till stripped, bare, and compacted areas thoroughly to a soil depth of **6 inches** .



- H. Apply soil amendments and initial fertilizer required for establishing new turf and mix thoroughly into top **4 inches** of existing soil. Install new planting soil to fill low spots and meet finish grades.
 - 1. Initial Fertilizer: Commercial fertilizer applied according to manufacturer's recommendations.
- I. Water newly planted areas and keep moist until new turf is established.

3.7 TURF MAINTENANCE

- A. General: Maintain and establish turf by watering, fertilizing, weeding, mowing, trimming, replanting, and performing other operations as required to establish healthy, viable turf. Roll, regrade, and replant bare or eroded areas and remulch to produce a uniformly smooth turf. Provide materials and installation the same as those used in the original installation.
 - 1. Fill in as necessary soil subsidence that may occur because of settling or other processes. Replace materials and turf damaged or lost in areas of subsidence.
 - 2. In areas where mulch has been disturbed by wind or maintenance operations, add new mulch and anchor as required to prevent displacement.
 - 3. Apply treatments as required to keep turf and soil free of pests and pathogens or disease. Use integrated pest management practices whenever possible to minimize the use of pesticides and reduce hazards.
- B. Watering: Install and maintain temporary piping, hoses, and turf-watering equipment to convey water from sources and to keep turf uniformly moist to a depth of **4 inches** .
 - 1. Schedule watering to prevent wilting, puddling, erosion, and displacement of seed or mulch. Lay out temporary watering system to avoid walking over muddy or newly planted areas.
 - 2. Water turf with fine spray at a minimum rate of **1 inch** per week unless rainfall precipitation is adequate.
- C. Mow turf as soon as top growth is tall enough to cut. Repeat mowing to maintain specified height without cutting more than one-third of grass height. Remove no more than one-third of grass-leaf growth in initial or subsequent mowings. Do not delay mowing until grass blades bend over and become matted. Do not mow when grass is wet. Schedule initial and subsequent mowings to maintain the following grass height:
 - 1. Mow to a height of **1-1/2 to 2 inches** .

3.8 SATISFACTORY TURF

- A. Turf installations shall meet the following criteria as determined by Landscape Architect:
 - 1. Satisfactory Seeded Turf: At end of maintenance period, a healthy, uniform, close stand of grass has been established, free of weeds and surface irregularities, with coverage exceeding 90 percent over any **10 sq. ft.** and bare spots not exceeding **5 by 5 inches** .



- B. Use specified materials to reestablish turf that does not comply with requirements, and continue maintenance until turf is satisfactory.

3.9 PESTICIDE APPLICATION

- A. Post-Emergent Herbicides (Selective and Nonselective): Apply only as necessary to treat already-germinated weeds and according to manufacturer's written recommendations.

3.10 CLEANUP AND PROTECTION

- A. Promptly remove soil and debris created by turf work from paved areas. Clean wheels of vehicles before leaving site to avoid tracking soil onto roads, walks, or other paved areas.
- B. Remove surplus soil and waste material, including excess subsoil, unsuitable soil, trash, and debris, and legally dispose of them off Owner's property.
- C. Erect temporary fencing or barricades and warning signs as required to protect newly planted areas from traffic. Maintain fencing and barricades throughout initial maintenance period and remove after plantings are established.

3.11 MAINTENANCE SERVICE

- A. Turf Maintenance Service: Provide full maintenance by skilled employees of landscape Installer. Maintain as required in "Turf Maintenance" Article. Begin maintenance immediately after each area is planted and continue until acceptable turf is established, but for not less than the following periods:
 - 1. Seeded Turf: 60 days from date of Substantial Completion .
 - a. When initial maintenance period has not elapsed before end of planting season, or if turf is not fully established, continue maintenance during next planting season.

END OF SECTION 329200



SECTION 329300 - PLANTS

PART 1 - GENERAL

1.1 RELATED DOCUMENTS

- A. Drawings and general provisions of the Contract, including General and Supplementary Conditions and Division 01 Specification Sections, apply to this Section.

1.2 SUMMARY

- A. Section Includes:

- 1. Plants.
- 2. Tree stabilization.
- 3. Landscape edgings.

- B. Related Requirements:

- 1. Section 015639 "Temporary Tree and Plant Protection" for protecting, trimming, pruning, repairing, and replacing existing trees to remain that interfere with, or are affected by, execution of the Work.
- 2. Section 329200 "Turf and Grasses" for turf (lawn) and meadow planting, hydroseeding, and erosion-control materials.

1.3 DEFINITIONS

- A. Backfill: The earth used to replace or the act of replacing earth in an excavation.
- B. Balled and Burlapped Stock: Plants dug with firm, natural balls of earth in which they were grown, with a ball size not less than diameter and depth recommended by ANSI Z60.1 for type and size of plant required; wrapped with burlap, tied, rigidly supported, and drum laced with twine with the root flare visible at the surface of the ball as recommended by ANSI Z60.1.
- C. Finish Grade: Elevation of finished surface of planting soil.
- D. Pesticide: A substance or mixture intended for preventing, destroying, repelling, or mitigating a pest. Pesticides include insecticides, miticides, herbicides, fungicides, rodenticides, and molluscicides. They also include substances or mixtures intended for use as a plant regulator, defoliant, or desiccant. Some sources classify herbicides separately from pesticides.
- E. Pests: Living organisms that occur where they are not desired or that cause damage to plants, animals, or people. Pests include insects, mites, grubs, mollusks (snails and slugs), rodents (gophers, moles, and mice), unwanted plants (weeds), fungi, bacteria, and viruses.
- F. Planting Area: Areas to be planted.



- G. Planting Soil: Existing, on-site soil; imported soil; or manufactured soil that has been modified with soil amendments and perhaps fertilizers to produce a soil mixture best for plant growth.
- H. Plant; Plants; Plant Material: These terms refer to vegetation in general, including trees, shrubs, vines, ground covers, ornamental grasses, bulbs, corms, tubers, or herbaceous vegetation.
- I. Root Flare: Also called "trunk flare." The area at the base of the plant's stem or trunk where the stem or trunk broadens to form roots; the area of transition between the root system and the stem or trunk.
- J. Stem Girdling Roots: Roots that encircle the stems (trunks) of trees below the soil surface.
- K. Subgrade: The surface or elevation of subsoil remaining after excavation is complete, or the top surface of a fill or backfill before planting soil is placed.

1.4 COORDINATION

- A. Coordination with Turf Areas (Lawns): Plant trees, shrubs, and other plants after finish grades are established and before planting turf areas unless otherwise indicated.
 - 1. When planting trees, shrubs, and other plants after planting turf areas, protect turf areas, and promptly repair damage caused by planting operations.

1.5 ACTION SUBMITTALS

- A. Product Data: For each type of product.
 - 1. Plant Materials: Include quantities, sizes, quality, and sources for plant materials.
 - 2. Plant Photographs: Include color photographs in digital format of each required species and size of plant material as it will be furnished to Project. Take photographs from an angle depicting true size and condition of the typical plant to be furnished. Include a scale rod or other measuring device in each photograph. For species where more than 20 plants are required, include a minimum of three photographs showing the average plant, the best quality plant, and the worst quality plant to be furnished. Identify each photograph with the full scientific name of the plant, plant size, and name of the growing nursery.

1.6 INFORMATIONAL SUBMITTALS

- A. Qualification Data: For landscape Installer. Include list of similar projects completed by Installer demonstrating Installer's capabilities and experience. Include project names, addresses, and year completed, and include names and addresses of owners' contact persons.
- B. Product Certificates: For each type of manufactured product, from manufacturer, and complying with the following:
 - 1. Manufacturer's certified analysis of standard products.
 - 2. Analysis of other materials by a recognized laboratory made according to methods established by the Association of Official Analytical Chemists, where applicable.



- C. Sample Warranty: For special warranty.

1.7 CLOSEOUT SUBMITTALS

1.8 QUALITY ASSURANCE

- A. Installer Qualifications: A qualified landscape installer whose work has resulted in successful establishment of plants.
 - 1. Professional Membership: Installer shall be a member in good standing of either the Professional Landcare Network or the American Nursery and Landscape Association.
 - 2. Experience: Five years' experience in landscape installation in addition to requirements in Section 014000 "Quality Requirements."
 - 3. Installer's Field Supervision: Require Installer to maintain an experienced full-time supervisor on Project site when work is in progress.
 - 4. Personnel Certifications: Installer's field supervisor shall have certification in one of the following categories from the Professional Landcare Network:
 - a. Landscape Industry Certified Technician - Exterior.
 - b. Landscape Industry Certified Interior.
 - c. Landscape Industry Certified Horticultural Technician.
 - 5. Pesticide Applicator: State licensed, commercial.
- B. Provide quality, size, genus, species, and variety of plants indicated, complying with applicable requirements in ANSI Z60.1.
 - 1. Selection of plants purchased under allowances is made by Architect, who tags plants at their place of growth before they are prepared for transplanting.
- C. Measurements: Measure according to ANSI Z60.1. Do not prune to obtain required sizes.
 - 1. Trees and Shrubs: Measure with branches and trunks or canes in their normal position. Take height measurements from or near the top of the root flare for field-grown stock and container-grown stock. Measure main body of tree or shrub for height and spread; do not measure branches or roots tip to tip. Take caliper measurements **6 inches** above the root flare for trees up to **4-inch** caliper size, and **12 inches** above the root flare for larger sizes.
 - 2. Other Plants: Measure with stems, petioles, and foliage in their normal position.
- D. Plant Material Observation: Architect may observe plant material either at place of growth or at site before planting for compliance with requirements for genus, species, variety, cultivar, size, and quality. Architect may also observe trees and shrubs further for size and condition of balls and root systems, pests, disease symptoms, injuries, and latent defects and may reject unsatisfactory or defective material at any time during progress of work. Remove rejected trees or shrubs immediately from Project site.
 - 1. Notify Architect of sources of planting materials seven days in advance of delivery to site.



1.9 DELIVERY, STORAGE, AND HANDLING

- A. Packaged Materials: Deliver packaged materials in original, unopened containers showing weight, certified analysis, name and address of manufacturer, and indication of compliance with state and Federal laws if applicable.
- B. Bulk Materials:
 - 1. Do not dump or store bulk materials near structures, utilities, walkways and pavements, or on existing turf areas or plants.
 - 2. Provide erosion-control measures to prevent erosion or displacement of bulk materials; discharge of soil-bearing water runoff; and airborne dust reaching adjacent properties, water conveyance systems, or walkways.
 - 3. Accompany each delivery of bulk materials with appropriate certificates.
- C. Do not prune trees and shrubs before delivery. Protect bark, branches, and root systems from sun scald, drying, wind burn, sweating, whipping, and other handling and tying damage. Do not bend or bind-tie trees or shrubs in such a manner as to destroy their natural shape. Provide protective covering of plants during shipping and delivery. Do not drop plants during delivery and handling.
- D. Handle planting stock by root ball.
- E. Apply antidesiccant to trees and shrubs using power spray to provide an adequate film over trunks (before wrapping), branches, stems, twigs, and foliage to protect during digging, handling, and transportation.
 - 1. If deciduous trees or shrubs are moved in full leaf, spray with antidesiccant at nursery before moving and again two weeks after planting.
- F. Wrap trees and shrubs with burlap fabric over trunks, branches, stems, twigs, and foliage to protect from wind and other damage during digging, handling, and transportation.
- G. Deliver plants after preparations for planting have been completed, and install immediately. If planting is delayed more than six hours after delivery, set plants and trees in their appropriate aspect (sun, filtered sun, or shade), protect from weather and mechanical damage, and keep roots moist.
 - 1. Set balled stock on ground and cover ball with soil, peat moss, sawdust, or other acceptable material.
 - 2. Do not remove container-grown stock from containers before time of planting.
 - 3. Water root systems of plants stored on-site deeply and thoroughly with a fine-mist spray. Water as often as necessary to maintain root systems in a moist, but not overly wet condition.

1.10 FIELD CONDITIONS

- A. Field Measurements: Verify actual grade elevations, service and utility locations, irrigation system components, and dimensions of plantings and construction contiguous with new plantings by field measurements before proceeding with planting work.



- B. Planting Restrictions: Plant during one of the following periods. Coordinate planting periods with maintenance periods to provide required maintenance from date of Substantial Completion.
 - 1. Spring Planting: March 15 - June 15 .
- C. Weather Limitations: Proceed with planting only when existing and forecasted weather conditions permit planting to be performed when beneficial and optimum results may be obtained. Apply products during favorable weather conditions according to manufacturer's written instructions and warranty requirements.

1.11 WARRANTY

- A. Special Warranty: Installer agrees to repair or replace plantings and accessories that fail in materials, workmanship, or growth within specified warranty period.
 - 1. Failures include, but are not limited to, the following:
 - a. Death and unsatisfactory growth, except for defects resulting from abuse, lack of adequate maintenance, or neglect by Owner.
 - b. Structural failures including plantings falling or blowing over.
 - c. Faulty performance of tree stabilization .
 - 2. Warranty Periods: From date of Substantial Completion .
 - a. Trees, Shrubs, Vines, and Ornamental Grasses: 12 months.
 - 3. Include the following remedial actions as a minimum:
 - a. Immediately remove dead plants and replace unless required to plant in the succeeding planting season.
 - b. Replace plants that are more than 25 percent dead or in an unhealthy condition at end of warranty period.
 - c. A limit of one replacement of each plant is required except for losses or replacements due to failure to comply with requirements.
 - d. Provide extended warranty for period equal to original warranty period, for replaced plant material.

PART 2 - PRODUCTS

2.1 PLANT MATERIAL

- A. General: Furnish nursery-grown plants true to genus, species, variety, cultivar, stem form, shearing, and other features indicated in Plant List, Plant Schedule, or Plant Legend indicated on Drawings and complying with ANSI Z60.1; and with healthy root systems developed by transplanting or root pruning. Provide well-shaped, fully branched, healthy, vigorous stock, densely foliated when in leaf and free of disease, pests, eggs, larvae, and defects such as knots, sun scald, injuries, abrasions, and disfigurement.
 - 1. Trees with damaged, crooked, or multiple leaders; tight vertical branches where bark is squeezed between two branches or between branch and trunk ("included bark"); crossing trunks; cut-off limbs more than **3/4 inch** in diameter; or with stem girdling roots are unacceptable.



2. Collected Stock: Do not use plants harvested from the wild, from native stands, from an established landscape planting, or not grown in a nursery unless otherwise indicated.
- B. Provide plants of sizes, grades, and ball or container sizes complying with ANSI Z60.1 for types and form of plants required. Plants of a larger size may be used if acceptable to Architect, with a proportionate increase in size of roots or balls.
- C. Root-Ball Depth: Furnish trees and shrubs with root balls measured from top of root ball, which begins at root flare according to ANSI Z60.1. Root flare shall be visible before planting.

2.2 FERTILIZERS

- A. Planting Tablets: Tightly compressed chip-type, long-lasting, slow-release, commercial-grade planting fertilizer in tablet form. Tablets shall break down with soil bacteria, converting nutrients into a form that can be absorbed by plant roots.
 1. Size: 10-gram tablets.
 2. Nutrient Composition: 20 percent nitrogen, 10 percent phosphorous, and 5 percent potassium, by weight plus micronutrients.

2.3 MULCHES

- A. Organic Mulch: Free from deleterious materials and suitable as a top dressing of trees and shrubs, consisting of one of the following:
 1. Type: Aged Pine or Hemlock Softwood Bark Mulch
 2. Color: Natural - no orange mulch.
- B. Compost Mulch: Well-composted, stable, and weed-free organic matter, pH of 5.5 to 8; moisture content 35 to 55 percent by weight; 100 percent passing through a 1-inch sieve; soluble-salt content of 2 to 5 dS/m; not exceeding 0.5 percent inert contaminants and free of substances toxic to plantings; and as follows:
 1. Organic Matter Content: 50 to 60 percent of dry weight.

2.4 TREE-STABILIZATION MATERIALS

- A. Root-Ball Stabilization Materials:
 1. Upright Stakes and Horizontal Hold-Down: Rough-sawn, sound, new hardwood or softwood, free of knots, holes, cross grain, and other defects, 2-by-2-inch nominal by length indicated; stakes pointed at one end.



2.5 MISCELLANEOUS PRODUCTS

- A. Mycorrhizal Fungi: Dry, granular inoculant containing at least 5300 spores per lb of vesicular-arbuscular mycorrhizal fungi and 95 million spores per lb of ectomycorrhizal fungi, 33 percent hydrogel, and a maximum of 5.5 percent inert material.

PART 3 - EXECUTION

3.1 EXAMINATION

- A. Examine areas to receive plants, with Installer present, for compliance with requirements and conditions affecting installation and performance of the Work.
 - 1. Verify that no foreign or deleterious material or liquid such as paint, paint washout, concrete slurry, concrete layers or chunks, cement, plaster, oils, gasoline, diesel fuel, paint thinner, turpentine, tar, roofing compound, or acid has been deposited in soil within a planting area.
 - 2. Verify that plants and vehicles loaded with plants can travel to planting locations with adequate overhead clearance.
 - 3. Suspend planting operations during periods of excessive soil moisture until the moisture content reaches acceptable levels to attain the required results.
 - 4. Uniformly moisten excessively dry soil that is not workable or which is dusty.
- B. If contamination by foreign or deleterious material or liquid is present in soil within a planting area, remove the soil and contamination as directed by Architect and replace with new planting soil.
- C. Proceed with installation only after unsatisfactory conditions have been corrected.

3.2 PREPARATION

- A. Protect structures, utilities, sidewalks, pavements, and other facilities and turf areas and existing plants from damage caused by planting operations.
- B. Install erosion-control measures to prevent erosion or displacement of soils and discharge of soil-bearing water runoff or airborne dust to adjacent properties and walkways.

3.3 PLANTING AREA ESTABLISHMENT

- A. General: Prepare planting area for soil placement and mix planting soil according to Section 329113 "Soil Preparation."
- B. Placing Planting Soil: Place and mix planting soil in-place over exposed subgrade .
- C. Before planting, obtain Architect's acceptance of finish grading; restore planting areas if eroded or otherwise disturbed after finish grading.



- D. Application of Mycorrhizal Fungi: At time directed by Architect, broadcast dry product uniformly over prepared soil at application rate according to manufacturer's written recommendations .

3.4 EXCAVATION FOR TREES AND SHRUBS

- A. Planting Pits and Trenches: Excavate circular planting pits.
 - 1. Excavate planting pits with sides sloping inward at a 45-degree angle. Excavations with vertical sides are unacceptable. Trim perimeter of bottom leaving center area of bottom raised slightly to support root ball and assist in drainage away from center. Do not further disturb base. Ensure that root ball will sit on undisturbed base soil to prevent settling. Scarify sides of planting pit smeared or smoothed during excavation.
 - 2. Excavate approximately three times as wide as ball diameter for balled and burlapped stock.
 - 3. Do not excavate deeper than depth of the root ball, measured from the root flare to the bottom of the root ball.
 - 4. If area under the plant was initially dug too deep, add soil to raise it to the correct level and thoroughly tamp the added soil to prevent settling.
 - 5. Maintain angles of repose of adjacent materials to ensure stability. Do not excavate subgrades of adjacent paving, structures, hardscapes, or other new or existing improvements.
 - 6. Maintain supervision of excavations during working hours.
 - 7. Keep excavations covered or otherwise protected when unattended by Installer's personnel.
- B. Backfill Soil: Subsoil and topsoil removed from excavations may be used as backfill soil unless otherwise indicated.
- C. Obstructions: Notify Architect if unexpected rock or obstructions detrimental to trees or shrubs are encountered in excavations.
- D. Drainage: Notify Architect if subsoil conditions evidence unexpected water seepage or retention in tree or shrub planting pits.
- E. Fill excavations with water and allow to percolate away before positioning trees and shrubs.

3.5 TREE, SHRUB, AND VINE PLANTING

- A. Inspection: At time of planting, verify that root flare is visible at top of root ball according to ANSI Z60.1. If root flare is not visible, remove soil in a level manner from the root ball to where the top-most root emerges from the trunk. After soil removal to expose the root flare, verify that root ball still meets size requirements.
- B. Roots: Remove stem girdling roots and kinked roots. Remove injured roots by cutting cleanly; do not break.
- C. Balled and Burlapped Stock: Set each plant plumb and in center of planting pit or trench with root flare **2 inches** above adjacent finish grades.

1. Backfill: Planting soil . For trees, use excavated soil for backfill.
 2. After placing some backfill around root ball to stabilize plant, carefully cut and remove burlap, rope, and wire baskets from tops of root balls and from sides, but do not remove from under root balls. Remove pallets, if any, before setting. Do not use planting stock if root ball is cracked or broken before or during planting operation.
 3. Backfill around root ball in layers, tamping to settle soil and eliminate voids and air pockets. When planting pit is approximately one-half filled, water thoroughly before placing remainder of backfill. Repeat watering until no more water is absorbed.
 4. Place planting tablets equally distributed around each planting pit when pit is approximately one-half filled. Place tablets beside the root ball about **1 inch** from root tips; do not place tablets in bottom of the hole.
 - a. Quantity: As indicated on Drawings Three for each caliper inch of plant .
 5. Continue backfilling process. Water again after placing and tamping final layer of soil.
- D. Slopes: When planting on slopes, set the plant so the root flare on the uphill side is flush with the surrounding soil on the slope; the edge of the root ball on the downhill side will be above the surrounding soil. Apply enough soil to cover the downhill side of the root ball.

3.6 TREE, SHRUB, AND VINE PRUNING

- A. Remove only dead, dying, or broken branches. Do not prune for shape.
- B. Do not apply pruning paint to wounds.

3.7 TREE STABILIZATION

- A. Trunk Stabilization by Upright Staking and Tying: Install trunk stabilization as follows unless otherwise indicated:
 1. Upright Staking and Tying: Stake trees of **2- through 5-inch** caliper. Stake trees of less than **2-inch** caliper only as required to prevent wind tip out. Use a minimum of three stakes of length required to penetrate at least **18 inches** below bottom of backfilled excavation and to extend one-third of trunk height above grade. Set vertical stakes and space to avoid penetrating root balls or root masses.
 2. Support trees with bands of flexible ties at contact points with tree trunk. Allow enough slack to avoid rigid restraint of tree.
 3. Support trees with two strands of tie wire, connected to the brass grommets of tree-tie webbing at contact points with tree trunk. Allow enough slack to avoid rigid restraint of tree.

3.8 PLANTING AREA MULCHING

- A. Mulch backfilled surfaces of planting areas and other areas indicated.
 1. Trees in Turf Areas: Apply organic mulch ring of **3-inch** average thickness, with **12-inch 36-inch** radius around trunks or stems. Do not place mulch within **3 inches** of trunks or stems.



3.9 PLANT MAINTENANCE

- A. Maintain plantings by pruning, cultivating, watering, weeding, fertilizing, mulching, restoring planting saucers, adjusting and repairing tree-stabilization devices, resetting to proper grades or vertical position, and performing other operations as required to establish healthy, viable plantings.
- B. Fill in, as necessary, soil subsidence that may occur because of settling or other processes. Replace mulch materials damaged or lost in areas of subsidence.
- C. Apply treatments as required to keep plant materials, planted areas, and soils free of pests and pathogens or disease. Use integrated pest management practices when possible to minimize use of pesticides and reduce hazards. Treatments include physical controls such as hosing off foliage, mechanical controls such as traps, and biological control agents.

3.10 REPAIR AND REPLACEMENT

- A. General: Repair or replace existing or new trees and other plants that are damaged by construction operations, in a manner approved by Architect.
 - 1. Submit details of proposed pruning and repairs.
 - 2. Perform repairs of damaged trunks, branches, and roots within 24 hours, if approved.
 - 3. Replace trees and other plants that cannot be repaired and restored to full-growth status, as determined by Architect.
- B. Remove and replace trees that are more than 50 percent dead or in an unhealthy condition before the end of the corrections period or are damaged during construction operations that Architect determines are incapable of restoring to normal growth pattern.
 - 1. Provide new trees of same size as those being replaced for each tree of **6 inches** or smaller in caliper size.
 - 2. Species of Replacement Trees: Same species being replaced .

3.11 CLEANING AND PROTECTION

- A. During planting, keep adjacent paving and construction clean and work area in an orderly condition. Clean wheels of vehicles before leaving site to avoid tracking soil onto roads, walks, or other paved areas.
- B. Remove surplus soil and waste material including excess subsoil, unsuitable soil, trash, and debris and legally dispose of them off Owner's property.
- C. Protect plants from damage due to landscape operations and operations of other contractors and trades. Maintain protection during installation and maintenance periods. Treat, repair, or replace damaged plantings.
- D. After installation and before Substantial Completion , remove nursery tags, nursery stakes, tie tape, labels, wire, burlap, and other debris from plant material, planting areas, and Project site.



- E. At time of Substantial Completion, verify that tree-watering devices are in good working order and leave them in place. Replace improperly functioning devices.

3.12 MAINTENANCE SERVICE

END OF SECTION 329300

COLLYER PARK IMPROVEMENTS

Providence, Rhode Island

PARK IMPROVEMENTS

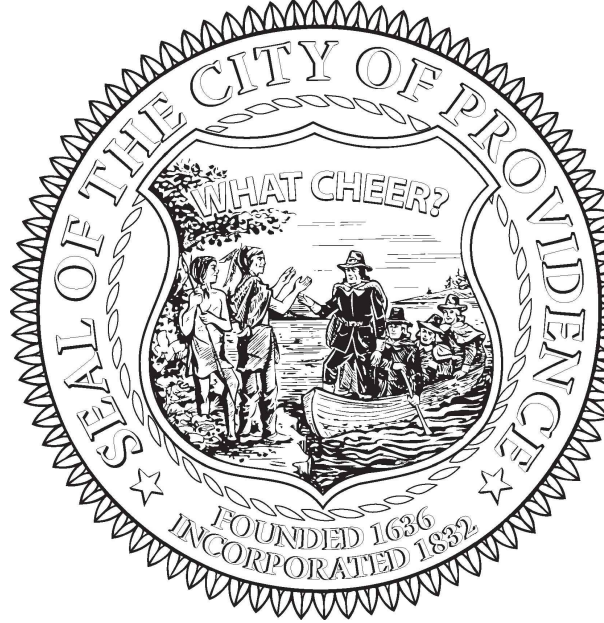

THE HONORABLE JORGE O. ELORZA, Mayor

NIRVA LaFORTUNE, City Councilor

WENDY NILSSON, Superintendent of Parks



INDEX TO DRAWINGS:

- E-1 EXISTING CONDITIONS
- L-1 DEMO PLAN
- L-2 MATERIALS PLAN
- I-1 IRRIGATION PLAN
- L-3 CONSTRUCTION DETAILS
- I-2 IRRIGATION DETAILS

Landscape Architect

GARDNER+GERRISH, LLC
151 Broadway, Suite 245
Providence, Rhode Island 02903
401.263.3784

Engineer

Narragansett Engineering Incorporated
151 Broadway, Suite 245
Providence, Rhode Island 02903
401.263.3784

ISSUED FOR BID - 29 SEPTEMBER 2021

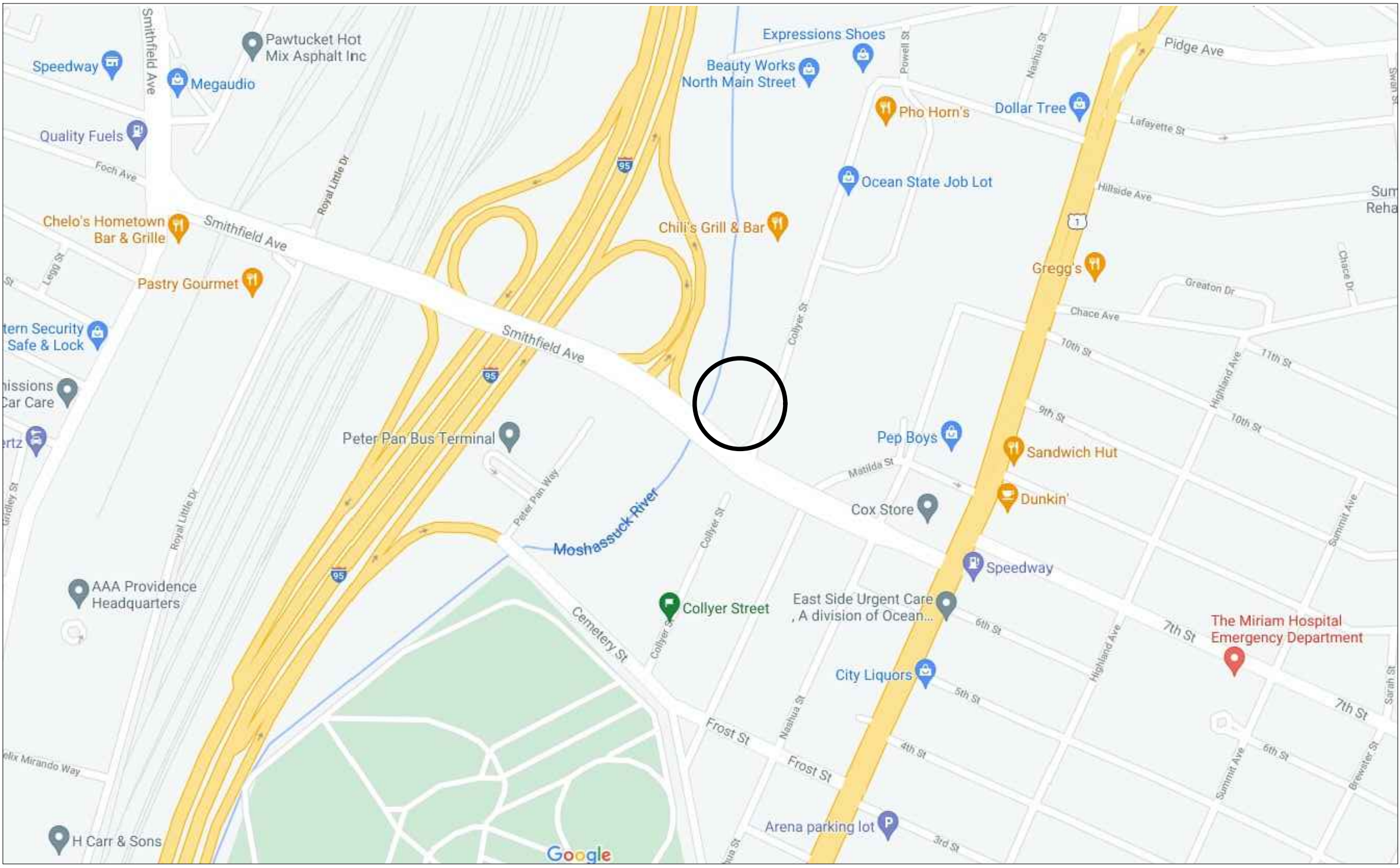

LOCUS MAP

not to scale

GENERAL NOTES:

1. ALL DISTURBED AREAS SHALL BE REPLACED IN KIND UNLESS OTHERWISE SHOWN.
2. THE DRAINAGE SYSTEM SHALL BE CLEANED BY THE CONTRACTOR PRIOR TO ACCEPTANCE OF THE PROJECT AT NO ADDITIONAL COST.
3. FOR ALL EXCAVATION AND PLACEMENT OF FILL, THE CONTRACTOR SHALL PERFORM THE WORK IN FULL COMPLIANCE WITH THE RHODE ISLAND STANDARD SPECIFICATION SECTION 202.
4. IN ADDITION TO THE CONTRACT DOCUMENT, SPECIFICATIONS TO GOVERN THIS PROJECT ARE RHODE ISLAND STANDARD SPECIFICATIONS FOR ROAD AND BRIDGE CONSTRUCTION 1997 EDITION INCLUDING ALL REVISIONS AND SUPPLEMENTAL SPECIFICATIONS. STANDARD DETAILS FOR THIS PROJECT ARE RHODE ISLAND STANDARD DETAILS.
5. WORK SHOWN ON THE PLANS FOR WHICH THERE ARE NO PARTICULAR DETAILS, "CALL-OUTS", OR SPECIFICATIONS DOES NOT RELIEVE THE CONTRACTOR FROM FURNISHING AND INSTALLING THE WORK. THE CONTRACTOR SHALL THOROUGHLY EXAMINE DETAILS, THE CONTRACT DOCUMENTS AND PLANS AND INSPECT THE SITE, AND THE BID PRICE SHALL INCLUDE ALL SERVICES AND MATERIALS NECESSARY TO COMPLETE THE PROJECT. ANY CHANGES TO THE PROJECT OR THE INSTALLATION OF AN ITEM FOR WHICH NO PARTICULAR DETAIL OR SPECIFICATION WAS PROVIDED MUST BE REVIEWED BY AND MUST BE ACCEPTABLE TO THE LANDSCAPE ARCHITECT.
6. IT IS THE SOLE RESPONSIBILITY OF THE CONTRACTOR TO ENSURE THAT THE CONDITIONS OF ALL PERMITS, SPECIFICATIONS, AS WELL AS FEDERAL, STATE AND LOCAL REGULATIONS ARE STRICTLY ENFORCED. THE CONTRACTOR SHALL ALSO BE RESPONSIBLE FOR ALL ASPECTS OF ON-SITE SAFETY.
7. THE CONTRACTOR SHALL VERIFY THE LOCATIONS OF ALL EXISTING DRAINAGE & UTILITIES, BOTH UNDERGROUND AND OVERHEAD, BEFORE EXCAVATION BEGINS IN ACCORDANCE WITH DISSAFE AND BY CONTACTING THE INDIVIDUAL UTILITY COMPANIES. EXCAVATION SHALL BE IN ACCORDANCE WITH ALL STATUTES, ORDINANCES, RULES AND REGULATIONS OF ANY CITY, STATE OR FEDERAL AGENCY THAT MAY BE APPLICABLE. ANY DAMAGE TO EXISTING UTILITIES SHALL BE THE CONTRACTOR'S RESPONSIBILITY.
8. THE CONTRACTOR SHALL BE RESPONSIBLE FOR ALL MAINTENANCE AND PROTECTION OF PEDESTRIAN AND VEHICULAR TRAFFIC INCLUDING POLICE PROTECTION. ALL TEMPORARY CONSTRUCTION SIGNS, BARRICADES AND LANE CLOSURES SHALL BE IN CONFORMANCE WITH THE MANUAL OF UNIFORM TRAFFIC CONTROL DEVICES (M.U.T.C.D.).
9. ALL REQUIRED AUTHORIZATION TO PERFORM WORK MUST BE OBTAINED BY THE CONTRACTOR PRIOR TO CONSTRUCTION.
10. THE SITE IS A PART OF A PREVIOUSLY DEVELOPED SITE WHOSE BUILDINGS WERE DEMOLISHED. GARDNER+GERRISH, LLC. DOES NOT MAKE ANY CLAIMS AS TO THE SUBSURFACE MATERIAL OR CONDITIONS.
11. CONSTRUCTION INDICATED ON THESE PLANS SHALL BE IN ACCORDANCE WITH THE LATEST REVISION OF AND MODIFICATIONS TO THE STATE OF RHODE ISLAND STANDARD SPECIFICATIONS FOR ROAD AND BRIDGE CONSTRUCTION AND THE SPECIFICATIONS ACCOMPANYING THESE PLANS. IN CASE OF CONFLICT, THE SPECIAL PROVISIONS OF THE SPECIFICATIONS ACCOMPANYING THESE PLANS SHALL GOVERN.
12. ALL ITEMS NOT REFERENCED FOR MODIFICATION WILL BE "EXISTING TO REMAIN" UNLESS OTHERWISE DIRECTED BY THE LANDSCAPE ARCHITECT.
13. ANY EXISTING PROPERTY THAT WAS NOT PROPOSED TO BE MODIFIED THAT IS DAMAGED BY THE CONTRACTOR SHALL BE REPAIRED BY THE CONTRACTOR AT NO ADDITIONAL COST TO THE CITY OF PROVIDENCE.
14. THE CONTRACTOR SHALL NOT BE ALLOWED TO STOCK PILE CONSTRUCTION MATERIALS WITHIN THE CLEAR ZONE DURING NON-WORKING HOURS. THE CONTRACTOR SHALL PLACE ALL STOCKPILED MATERIAL IN A PLACE DESIGNATED BY THE LANDSCAPE ARCHITECT SO AS NOT TO CAUSE A SAFETY HAZARD.
15. THE FREQUENCY AND APPLICATION RATES FROM DUST CONTROL ITEMS WILL BE DETERMINED BY THE CONTRACTOR. CALCIUM CHLORIDE SHALL NOT BE USED FOR DUST CONTROL.
16. DIMENSIONS SHOWN ON THE PLANS ARE APPROXIMATE.
17. ANY SIDEWALK OR ROADWAY DISTURBED BY CONSTRUCTION ACTIVITY SHALL BE REPAIRED BY THE CONTRACTOR AT NO ADDITIONAL COST. THE COST SHALL BE CONSIDERED INCIDENTAL TO THE PRICE BID FOR THE ASSOCIATED WORK ITEM CAUSING THE DAMAGE. ANY SIDEWALKS OR ROADWAYS DAMAGED, OR TO BE RESTORED SHALL MATCH THE SAME MATERIAL THAT EXISTS, INCLUDING CONCRETE BASE, UNLESS OTHERWISE INDICATED ON THE PLANS.
18. BUILDING SERVICE CONNECTIONS (ELECTRIC, WATER AND SANITARY) ARE SHOWN WHEREVER POSSIBLE. THE CONTRACTOR IS TO ASSUME THAT SERVICES ARE PRESENT TO ALL BUILDINGS. THEIR LOCATIONS ARE TO BE CHECKED WITH THE APPROPRIATE UTILITY COMPANIES.
19. THE CONTRACTOR SHALL TAKE ALL NECESSARY PRECAUTIONS TO PREVENT DAMAGE TO WALLS, LOT CURBS AND FENCES ADJUTING SIDEWALKS DESIGNATED FOR REPLACEMENT OR REMOVAL, WHERE DIRECTED. NEW SIDEWALKS SHALL MEET SAID WALLS AND FENCES. PRIOR TO SIDEWALK REMOVAL, A SAW CUT SHALL BE PROVIDED IN ALL SIDEWALKS TO BE REMOVED A DISTANCE, TO BE DETERMINED BY THE LANDSCAPE ARCHITECT (6 INCHES MINIMUM) FROM THE FACE OF ADJACENT BUILDINGS, RETAINING WALLS, LOT CURBS AND FENCES. THE FINAL SIX INCHES (MINIMUM) OF SIDEWALK SHALL BE REMOVED WITH CAUTION UNDER THE RESIDENT ENGINEERS SUPERVISION. THERE WILL BE NO ADDITIONAL PAYMENT FOR ANY LABOR OR EQUIPMENT NECESSARY TO MEET THIS "REMOVE WITH CAUTION" REQUIREMENT. PAYMENT OF THE REMOVAL OF THE FINAL (6" MINIMUM) OF SIDEWALK WILL BE INCLUDED UNDER CODE 201.0403 "REMOVE AND DISPOSE SIDEWALKS". THE REQUIRED SAW CUT WILL BE PAID FOR UNDER 932.0230 "FULL DEPTH SAW CUT OF PORTLAND CEMENT CONCRETE SIDEWALK/DRIVEWAY" WHICH EVER POSSIBLE.

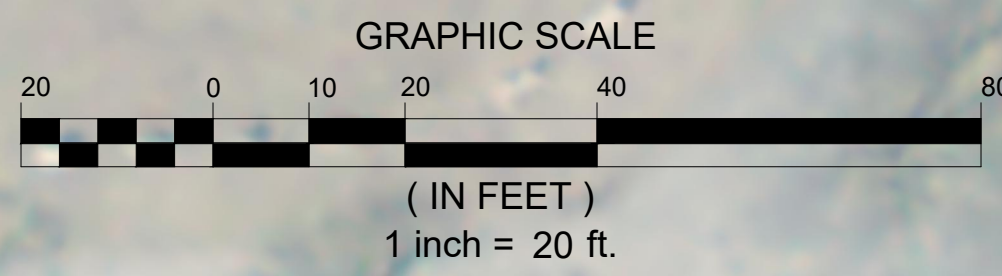
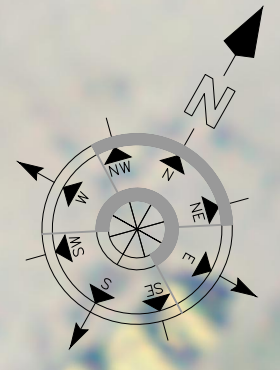

- EXISTING CONDITION NOTES:**
1. BASE INFORMATION (ORTHOPHOTO) OBTAINED FROM RI DIVISION OF STATEWIDE PLANNING DATED 2014 AT 1' RESOLUTION. ALL EXISTING CONDITIONS ARE TO BE CONSIDERED APPROXIMATE. NO REGISTERED SURVEY WAS OBTAINED FOR THE PRODUCTION OF THE EXISTING CONDITIONS PLAN.
 2. ANY ERRORS OR DISCREPANCIES ON THE DRAWINGS, SHOP DRAWINGS, AND DETAILS ARE TO BE BROUGHT TO THE ATTENTION OF THE OWNER'S REPRESENTATIVE BEFORE THE WORK HAS COMMENCED.
 3. THE CONTRACTOR IS RESPONSIBLE FOR FIELD VERIFICATION OF ALL LOCATIONS AND DIMENSIONS. DISCREPANCIES BETWEEN LAYOUT DIMENSIONS ON PLANS AND ACTUAL MEASUREMENTS IN FIELD ARE TO BE REPORTED TO THE OWNER'S REPRESENTATIVE BEFORE CONSTRUCTION BEGINS.
 4. THE CONTRACTOR SHALL NOTIFY THE OWNER'S REPRESENTATIVE PRIOR TO DEMOLITION OR INSTALLATION OF ANY PORTION OF THE SITE WORK.
 5. THE CONTRACTOR SHALL STAKE OUT ALL LAYOUTS OF PROPOSED WORK FOR APPROVAL BY THE OWNER'S REPRESENTATIVE PRIOR TO COMMENCING WORK.
 6. ANY AREAS DISTURBED BY EQUIPMENT AND/OR MATERIAL STORAGE ARE TO BE RESTORED TO ORIGINAL OR BETTER CONDITION BY THE CONTRACTOR AT THE CONTRACTOR'S EXPENSE BEFORE COMPLETION OF THE PROJECT, AND ARE SUBJECT TO APPROVAL BY OWNER'S REPRESENTATIVE.
 7. THE CONTRACTOR IS RESPONSIBLE FOR KEEPING THE SITE CLEAN OF MISCELLANEOUS DEBRIS THROUGHOUT THE CONSTRUCTION PERIOD. ALL WASTE MATERIAL IS TO BE LEGALLY DISPOSED OF AT AN OFF-SITE LOCATION, UNLESS OTHERWISE INDICATED ON THE PLAN.
 8. THE CONTRACTOR IS RESPONSIBLE FOR SECURING THE SITE FOR THE SAFETY OF THE GENERAL PUBLIC AND TO PROTECT PROPERTY AGAINST VANDALISM AND THEFT.
 9. THE CONTRACTOR MUST OBTAIN ALL REQUIRED CITY, STATE AND FEDERAL PERMITS. THE PROVIDENCE PARKS DEPARTMENT ASSUMES NO RESPONSIBILITY IF THE WORK IS NOT INSTALLED AS PER THE PLANS OR IF FIELD CHANGES ARE MADE WITHOUT THE KNOWLEDGE AND APPROVAL OF OWNER'S REPRESENTATIVE.

| NO. | REVISIONS | BY | DATE |
|-----|-----------|----|------|
| | | | |
| | | | |
| | | | |

Existing
Plan

PROVIDENCE PARKS DEPARTMENT
Collyer Park Improvements
Providence, Rhode Island

| | | | |
|-------------|-----|--------------|----------|
| DESIGNED BY | TDG | DWG SCALE | 1" = 20' |
| DRAWN BY | SJC | CONTRACT NO. | |
| CHECKED BY | TDG | DATE | 09.29.21 |

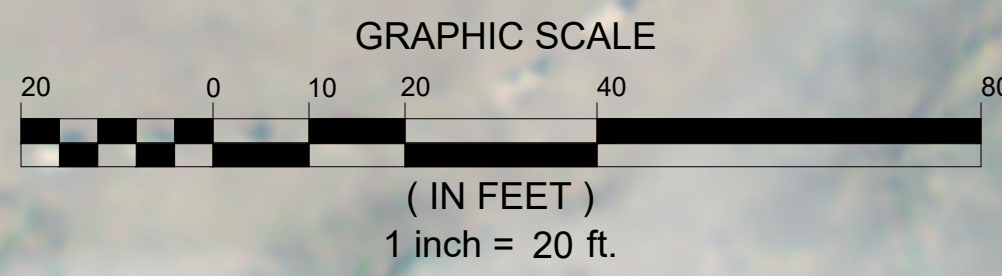
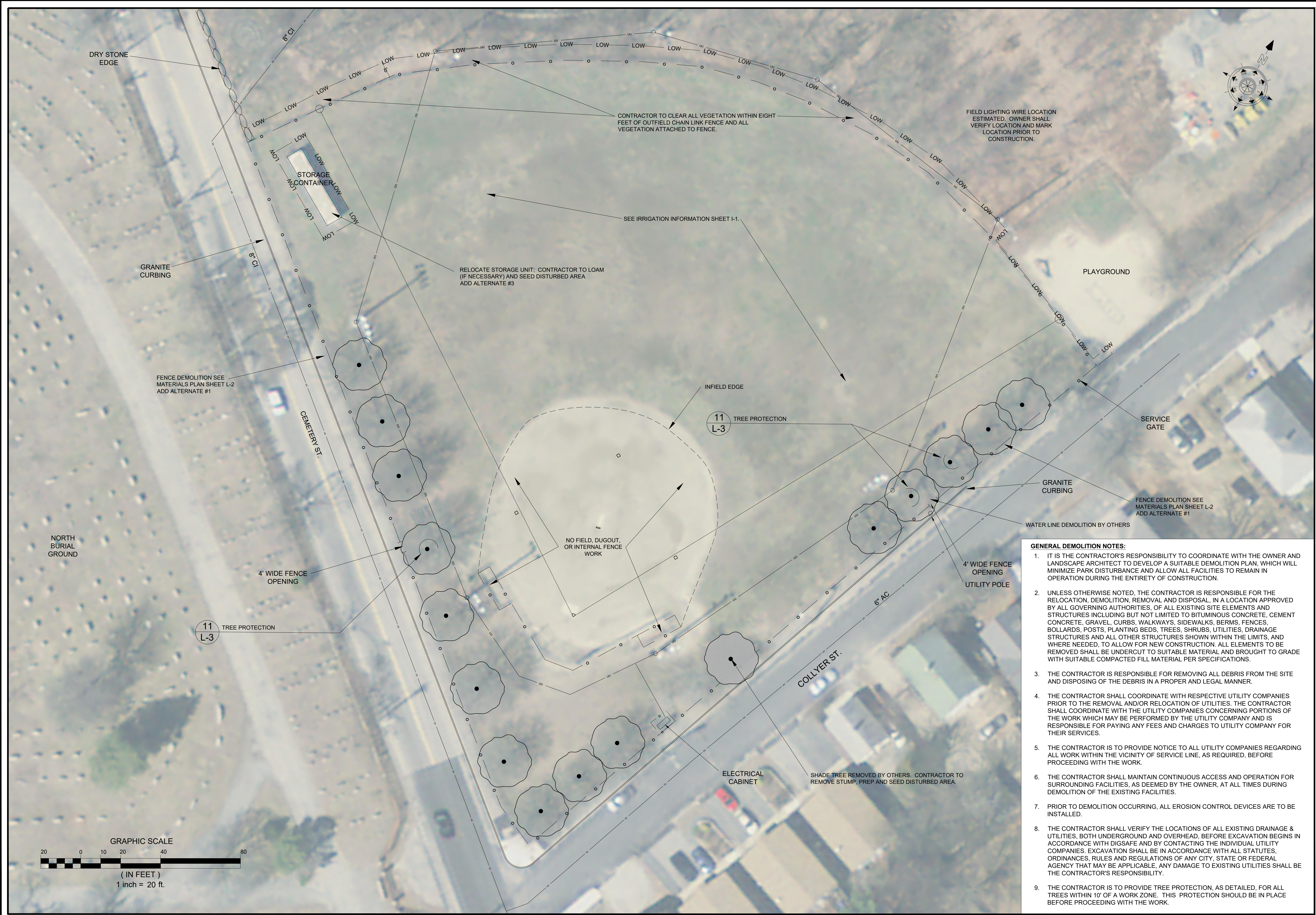

- GENERAL DEMOLITION NOTES:**
1. IT IS THE CONTRACTOR'S RESPONSIBILITY TO COORDINATE WITH THE OWNER AND LANDSCAPE ARCHITECT TO DEVELOP A SUITABLE DEMOLITION PLAN, WHICH WILL MINIMIZE PARK DISTURBANCE AND ALLOW ALL FACILITIES TO REMAIN IN OPERATION DURING THE ENTIRETY OF CONSTRUCTION.
 2. UNLESS OTHERWISE NOTED, THE CONTRACTOR IS RESPONSIBLE FOR THE RELOCATION, DEMOLITION, REMOVAL AND DISPOSAL, IN A LOCATION APPROVED BY ALL GOVERNING AUTHORITIES, OF ALL EXISTING SITE ELEMENTS AND STRUCTURES INCLUDING BUT NOT LIMITED TO BITUMINOUS CONCRETE, CEMENT CONCRETE, GRAVEL, CURBS, WALKWAYS, SIDEWALKS, BERMS, FENCES, BOLLARDS, POSTS, PLANTING BEDS, TREES, SHRUBS, UTILITIES, DRAINAGE STRUCTURES AND ALL OTHER STRUCTURES SHOWN WITHIN THE LIMITS, AND WHERE NEEDED, TO ALLOW FOR NEW CONSTRUCTION. ALL ELEMENTS TO BE REMOVED SHALL BE UNDERCUT TO SUITABLE MATERIAL AND BROUGHT TO GRADE WITH SUITABLE COMPACTED FILL MATERIAL PER SPECIFICATIONS.
 3. THE CONTRACTOR IS RESPONSIBLE FOR REMOVING ALL DEBRIS FROM THE SITE AND DISPOSING OF THE DEBRIS IN A PROPER AND LEGAL MANNER.
 4. THE CONTRACTOR SHALL COORDINATE WITH RESPECTIVE UTILITY COMPANIES PRIOR TO THE REMOVAL AND/OR RELOCATION OF UTILITIES. THE CONTRACTOR SHALL COORDINATE WITH THE UTILITY COMPANIES CONCERNING PORTIONS OF THE WORK WHICH MAY BE PERFORMED BY THE UTILITY COMPANY AND IS RESPONSIBLE FOR PAYING ANY FEES AND CHARGES TO UTILITY COMPANY FOR THEIR SERVICES.
 5. THE CONTRACTOR IS TO PROVIDE NOTICE TO ALL UTILITY COMPANIES REGARDING ALL WORK WITHIN THE VICINITY OF SERVICE LINE, AS REQUIRED, BEFORE PROCEEDING WITH THE WORK.
 6. THE CONTRACTOR SHALL MAINTAIN CONTINUOUS ACCESS AND OPERATION FOR SURROUNDING FACILITIES, AS DEEMED BY THE OWNER, AT ALL TIMES DURING DEMOLITION OF THE EXISTING FACILITIES.
 7. PRIOR TO DEMOLITION OCCURRING, ALL EROSION CONTROL DEVICES ARE TO BE INSTALLED.
 8. THE CONTRACTOR SHALL VERIFY THE LOCATIONS OF ALL EXISTING DRAINAGE & UTILITIES, BOTH UNDERGROUND AND OVERHEAD, BEFORE EXCAVATION BEGINS IN ACCORDANCE WITH DIGSAFE AND BY CONTACTING THE INDIVIDUAL UTILITY COMPANIES. EXCAVATION SHALL BE IN ACCORDANCE WITH ALL STATUTES, ORDINANCES, RULES AND REGULATIONS OF ANY CITY, STATE OR FEDERAL AGENCY THAT MAY BE APPLICABLE, ANY DAMAGE TO EXISTING UTILITIES SHALL BE THE CONTRACTOR'S RESPONSIBILITY.
 9. THE CONTRACTOR IS TO PROVIDE TREE PROTECTION, AS DETAILED, FOR ALL TREES WITHIN 10' OF A WORK ZONE. THIS PROTECTION SHOULD BE IN PLACE BEFORE PROCEEDING WITH THE WORK.

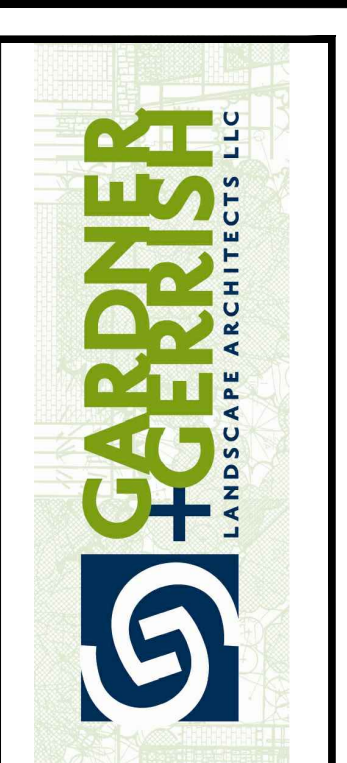

| NO. | REVISIONS | BY | DATE |
|-----|-----------|----|------|
| | | | |
| | | | |
| | | | |

Demolition Plan



PROVIDENCE PARKS DEPARTMENT
 Collyer Park Improvements
 Providence, Rhode Island

| | | | |
|-------------|------|--------------|----------|
| DESIGNED BY | TDVG | DWG SCALE | 1" = 40' |
| DRAWN BY | SJC | CONTRACT NO. | |
| CHECKED BY | TDVG | DATE | 09.29.21 |

L-1

| NO. | REVISIONS | BY | DATE |
|-----|-----------|----|------|
| | | | |
| | | | |
| | | | |

Materials Plan

PROVIDENCE PARKS DEPARTMENT
Collyer Park Improvements
Providence, Rhode Island

| | | | |
|-------------|-----|--------------|----------|
| DESIGNED BY | TDG | DWG SCALE | 1" = 20' |
| DRAWN BY | SJC | CONTRACT NO. | |
| CHECKED BY | TDG | DATE | 09.29.21 |

L-2



| TREES | CODE | QTY | BOTANICAL / COMMON NAME | CONT. | SIZE | MATURE |
|-------|------|-----|--|-------|---------|-----------|
| | CB | 1 | Cedrus atlantica 'Blue Cascade' / Blue Cascade Atlas Cedar | B & B | 8 - 10' | 40' - 65' |

FENCE TOP PROTECTION SHALL BE "ORIGINAL FENCE GUARD #01166 AS MANUFACTURED BY WHITE LINE EQUIPMENT CO. OR EQUAL. FENCE GUARD TIES #03023 INCLUDED

COPYRIGHT (C) BY GARDNER+GERRISH, LLC
ALL RIGHTS RESERVED

NO PART OF THIS DOCUMENT MAY BE REPRODUCED, STORED IN A RETRIEVAL SYSTEM, OR TRANSMITTED IN ANY FORM OR BY ANY MEANS, ELECTRONIC, MECHANICAL, PHOTOCOPYING, RECORDING, OR OTHERWISE, WITHOUT THE WRITTEN PERMISSION OF GARDNER+GERRISH, LLC. ANY VIOLATIONS TO THIS DOCUMENT WITHOUT THE WRITTEN PERMISSION OF GARDNER+GERRISH, LLC SHALL RENDER IT INVALID AND UNLAWFUL.

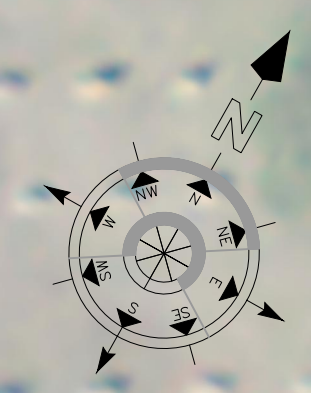
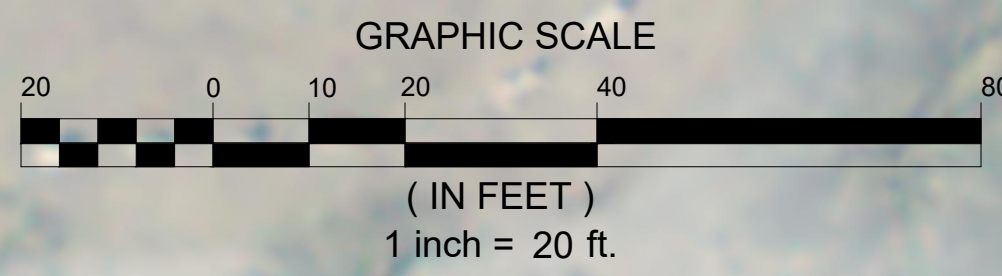

| NO. | REVISIONS | BY | DATE |
|-----|-----------|----|------|
| | | | |

Irrigation Plan

PROVIDENCE PARKS DEPARTMENT
Collyer Park Improvements
Providence, Rhode Island

| | | | |
|-------------|------|--------------|----------|
| DESIGNED BY | TWGS | SCALE | 1" = 20' |
| DRAWN BY | SJC | CONTRACT NO. | |
| CHECKED BY | TDBG | DATE | 09.29.21 |

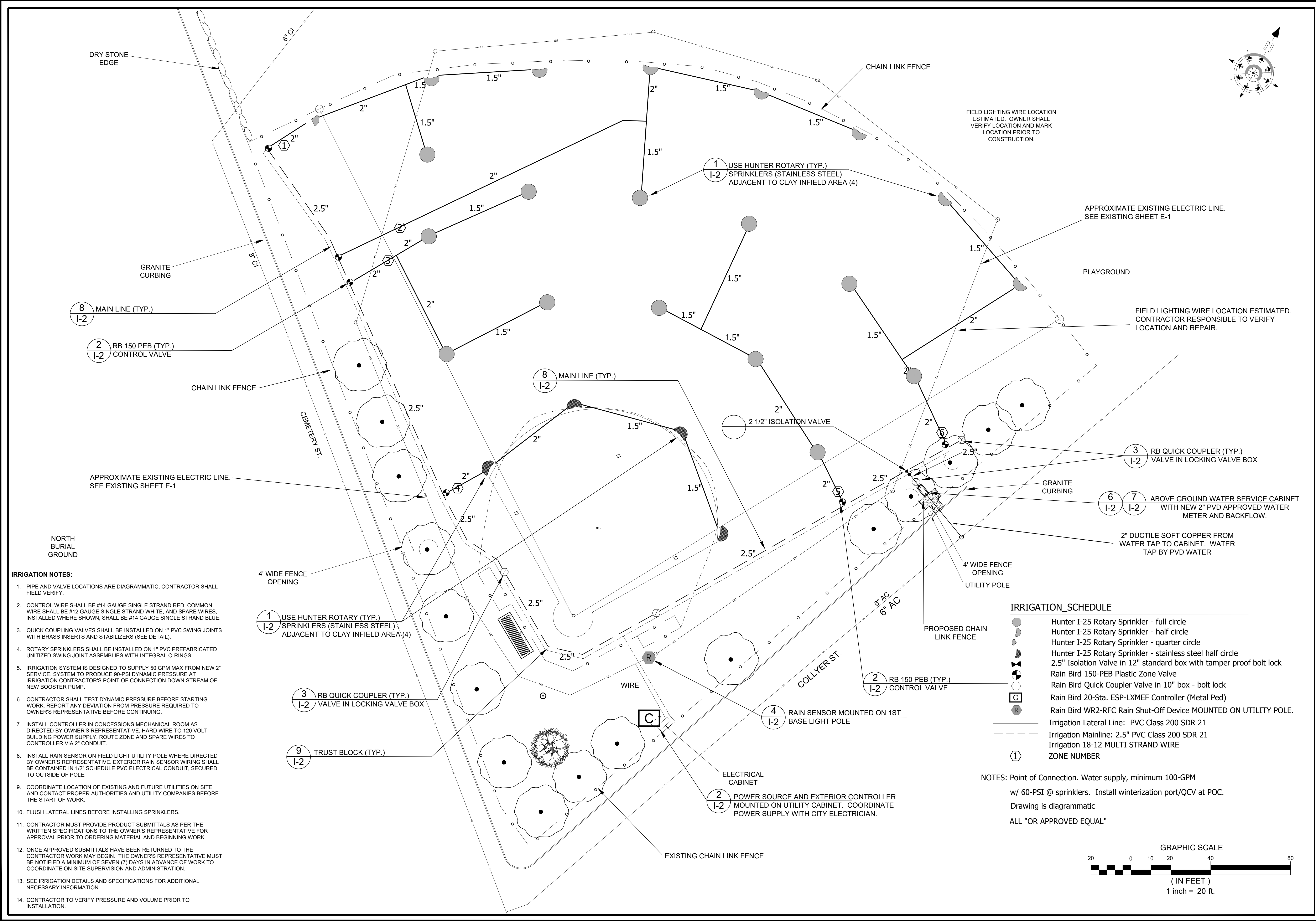

- IRRIGATION NOTES:**
- PIPE AND VALVE LOCATIONS ARE DIAGRAMMATIC. CONTRACTOR SHALL FIELD VERIFY.
 - CONTROL WIRE SHALL BE #14 GAUGE SINGLE STRAND RED, COMMON WIRE SHALL BE #12 GAUGE SINGLE STRAND WHITE, AND SPARE WIRES, INSTALLED WHERE SHOWN, SHALL BE #14 GAUGE SINGLE STRAND BLUE.
 - QUICK COUPLING VALVES SHALL BE INSTALLED ON 1" PVC SWING JOINTS WITH BRASS INSERTS AND STABILIZERS (SEE DETAIL).
 - ROTARY SPRINKLERS SHALL BE INSTALLED ON 1" PVC PREFABRICATED UNITIZED SWING JOINT ASSEMBLIES WITH INTEGRAL O-RINGS.
 - IRRIGATION SYSTEM IS DESIGNED TO SUPPLY 50 GPM MAX FROM NEW 2" SERVICE. SYSTEM TO PRODUCE 90-PSI DYNAMIC PRESSURE AT IRRIGATION CONTRACTOR'S POINT OF CONNECTION DOWN STREAM OF NEW BOOSTER PUMP.
 - CONTRACTOR SHALL TEST DYNAMIC PRESSURE BEFORE STARTING WORK. REPORT ANY DEVIATION FROM PRESSURE REQUIRED TO OWNER'S REPRESENTATIVE BEFORE CONTINUING.
 - INSTALL CONTROLLER IN CONCESSIONS MECHANICAL ROOM AS DIRECTED BY OWNER'S REPRESENTATIVE. HARD WIRE TO 120 VOLT BUILDING POWER SUPPLY. ROUTE ZONE AND SPARE WIRES TO CONTROLLER VIA 2" CONDUIT.
 - INSTALL RAIN SENSOR ON FIELD LIGHT UTILITY POLE WHERE DIRECTED BY OWNER'S REPRESENTATIVE. EXTERIOR RAIN SENSOR WIRING SHALL BE CONTAINED IN 1/2" SCHEDULE PVC ELECTRICAL CONDUIT, SECURED TO OUTSIDE OF POLE.
 - COORDINATE LOCATION OF EXISTING AND FUTURE UTILITIES ON SITE AND CONTACT PROPER AUTHORITIES AND UTILITY COMPANIES BEFORE THE START OF WORK.
 - FLUSH LATERAL LINES BEFORE INSTALLING SPRINKLERS.
 - CONTRACTOR MUST PROVIDE PRODUCT SUBMITTALS AS PER THE WRITTEN SPECIFICATIONS TO THE OWNER'S REPRESENTATIVE FOR APPROVAL PRIOR TO ORDERING MATERIAL AND BEGINNING WORK.
 - ONCE APPROVED SUBMITTALS HAVE BEEN RETURNED TO THE CONTRACTOR WORK MAY BEGIN. THE OWNER'S REPRESENTATIVE MUST BE NOTIFIED A MINIMUM OF SEVEN (7) DAYS IN ADVANCE OF WORK TO COORDINATE ON-SITE SUPERVISION AND ADMINISTRATION.
 - SEE IRRIGATION DETAILS AND SPECIFICATIONS FOR ADDITIONAL NECESSARY INFORMATION.
 - CONTRACTOR TO VERIFY PRESSURE AND VOLUME PRIOR TO INSTALLATION.

- IRRIGATION_SCHEDULE**
- Hunter I-25 Rotary Sprinkler - full circle
 - ◐ Hunter I-25 Rotary Sprinkler - half circle
 - ◑ Hunter I-25 Rotary Sprinkler - quarter circle
 - ◒ Hunter I-25 Rotary Sprinkler - stainless steel half circle
 - 2.5" Isolation Valve in 12" standard box with tamper proof bolt lock
 - ⊕ Rain Bird 150-PEB Plastic Zone Valve
 - ⊖ Rain Bird Quick Coupler Valve in 10" box - bolt lock
 - ⊗ Rain Bird 20-Sta. ESP-LXMEF Controller (Metal Ped)
 - Ⓡ Rain Bird WR2-RFC Rain Shut-Off Device MOUNTED ON UTILITY POLE.
 - Irrigation Lateral Line: PVC Class 200 SDR 21
 - - - Irrigation Mainline: 2.5" PVC Class 200 SDR 21
 - Ⓛ Irrigation 18-12 MULTI STRAND WIRE
 - ① ZONE NUMBER

NOTES: Point of Connection. Water supply, minimum 100-GPM w/ 60-PSI @ sprinklers. Install winterization port/QCV at POC. Drawing is diagrammatic ALL "OR APPROVED EQUAL"

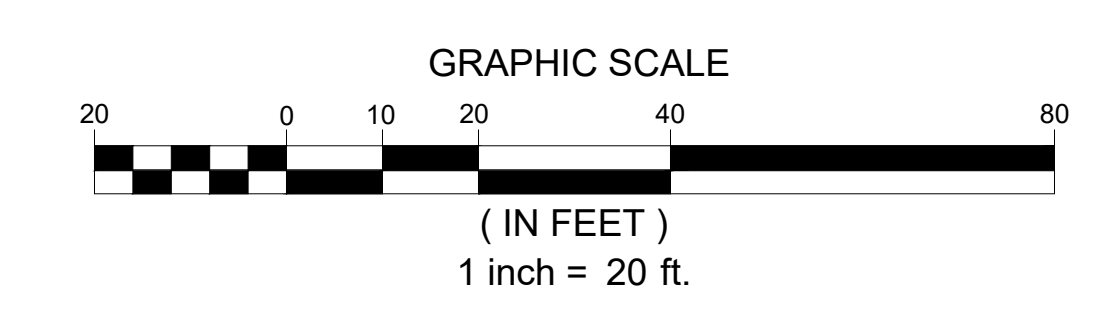

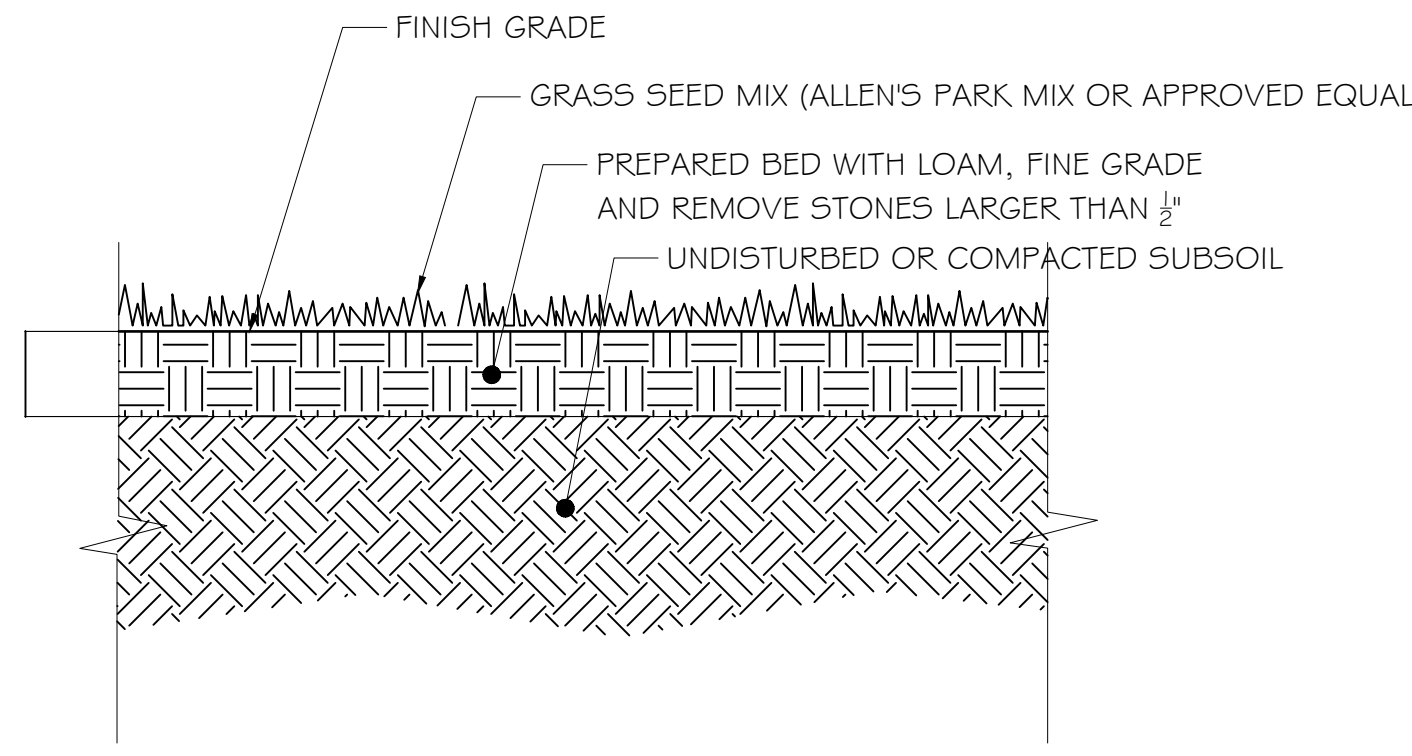

1 LOAM AND SEED No Scale

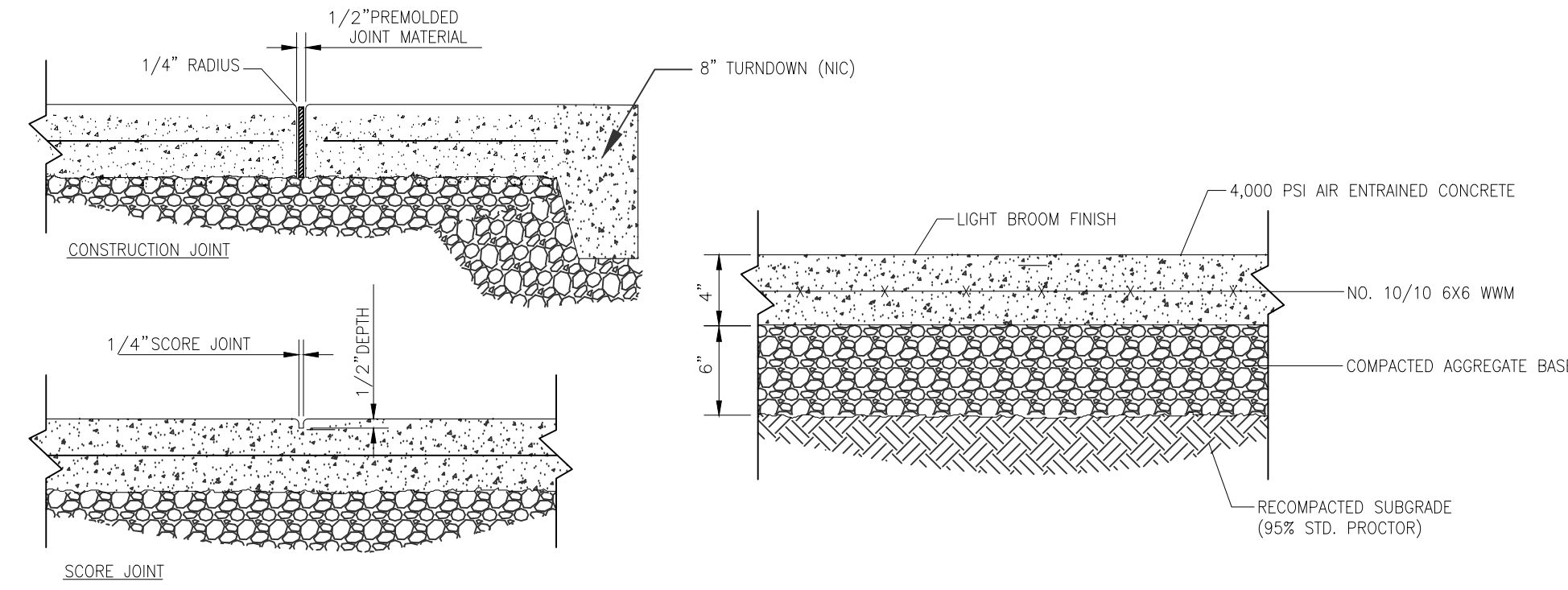

2 CONCRETE PAD ADD ALTERNATE #5 No Scale

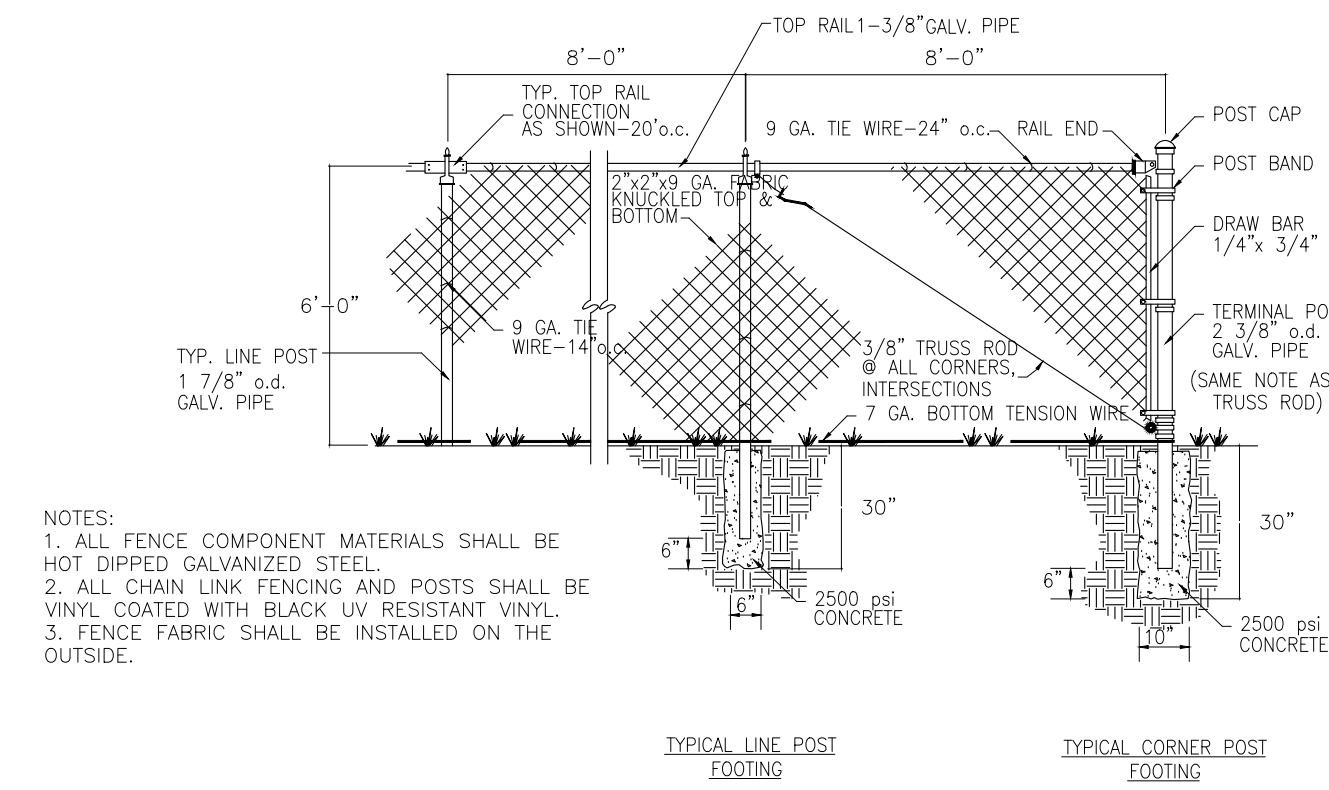

3 4' - 6' HIGH CHAIN LINK FENCE ADD ALTERNATE #1 No Scale

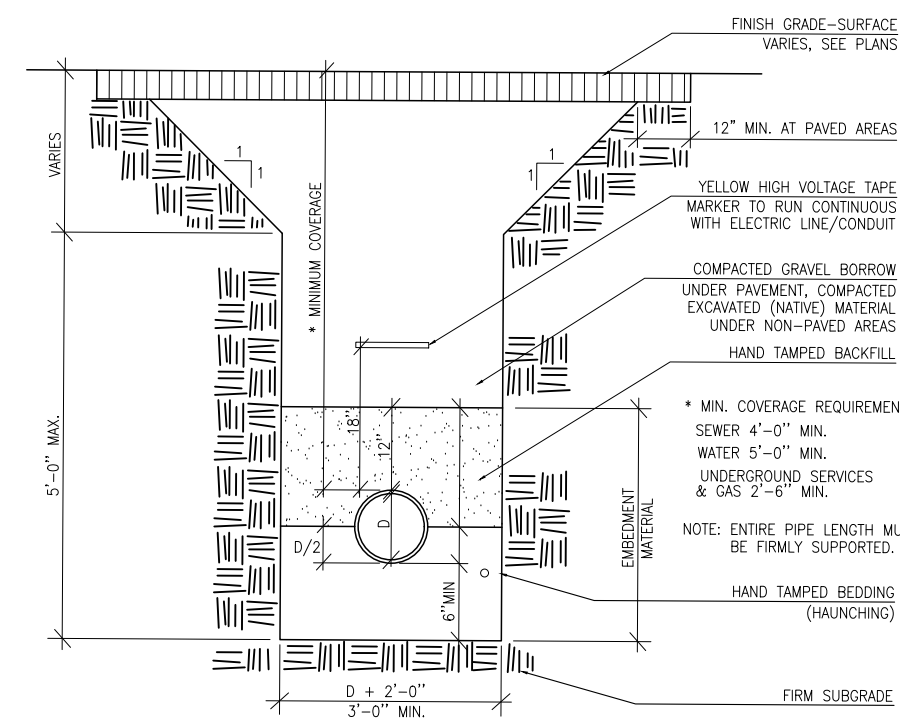

4 ELECTRICAL CONDUIT TRENCH No Scale

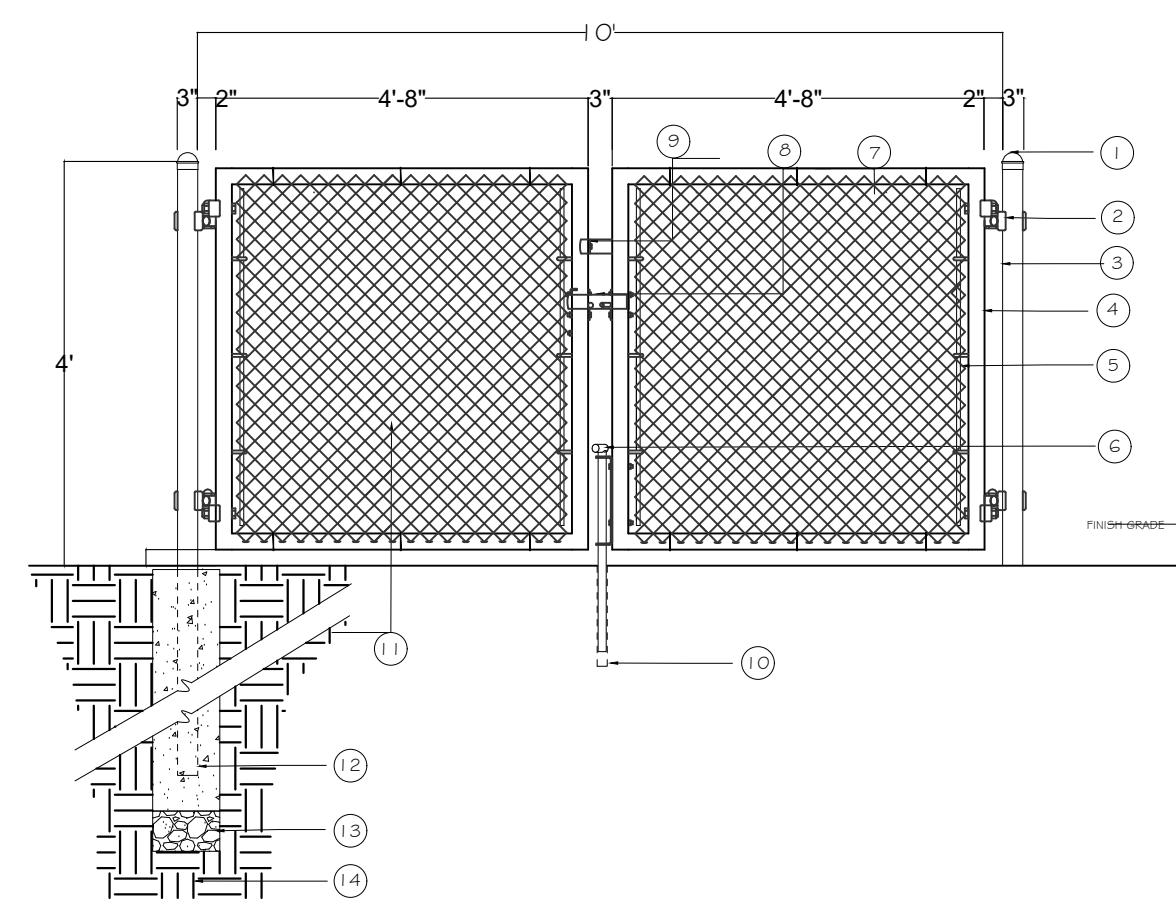

5 SERVICE GATES DETAIL ADD ALTERNATE #1 No Scale

- CONSTRUCTION NOTES:**
- FOOTING WIDTH TO BE (4X POST WIDTH) MINIMUM DEPTH 36"
 - ALL POSTS, RAILS, BRACES AND ACCESSORIES SHALL BE GALVANIZED STEEL WITH A PROTECTED ZINC COATING
- NOTES:**
1. DOME POST CAP
 2. HINGE
 3. 3" OD GALVANIZED STEEL POST
 4. 1-5/8" OD GALVANIZED STEEL FRAME
 5. HIGH CARBON STEEL TENSION BAR
 6. 1/2" GALVANIZED STEEL GROUND PEG
 7. WIRE TIES
 8. LATCH
 9. BACK STOP PLATE
 10. PVC PIPE
 11. CHAIN LINK FABRIC
 12. CONCRETE FOOTING
 13. 6" AT 90% COMPACTION PROCESSED GRAVEL BASE
 14. UNDISTURBED SUBSOIL

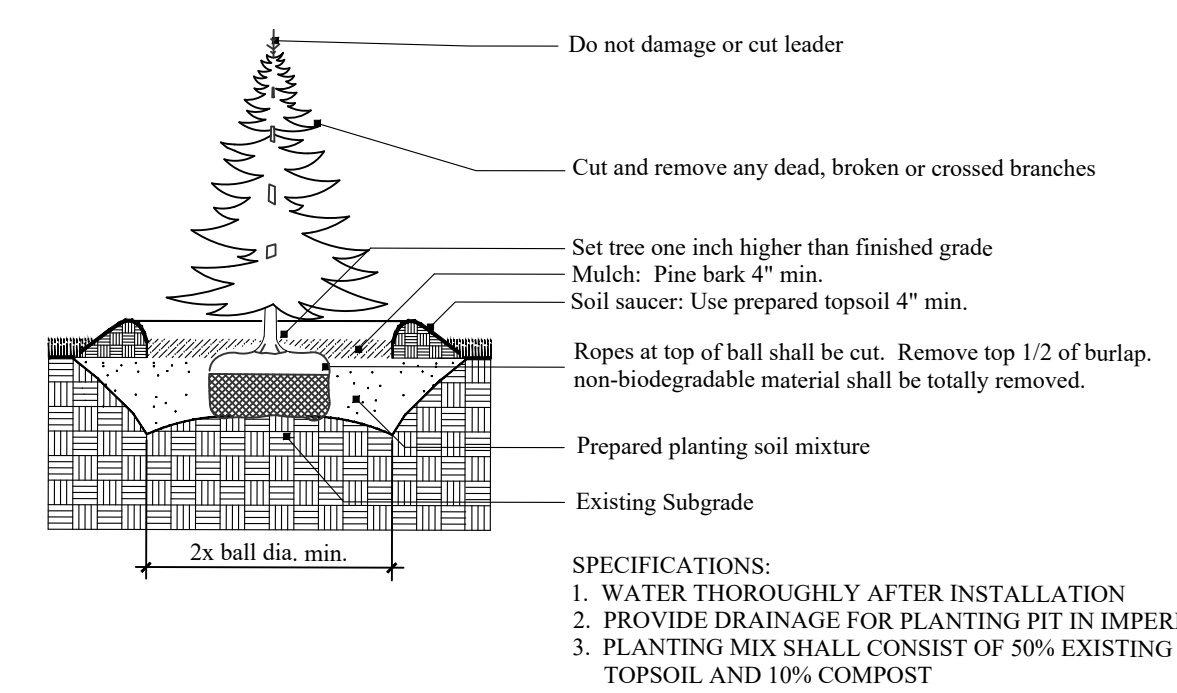

6 TYPICAL EVERGREEN TREE PLANTING ADD ALTERNATE #7 No Scale

- PLANTING NOTES**
1. ALL NEW PLANT MATERIALS SHALL CONFORM TO THE MINIMUM GUIDELINES ESTABLISHED FOR NURSERY STOCK PUBLISHED BY THE AMERICAN ASSOCIATION OF NURSERYMEN, INC. IN ADDITION, ALL NEW PLANT MATERIAL FOR THE PROJECT SHALL BE OF SPECIMEN QUALITY.
 2. ALL NEW PLANTS TO BE BALLED AND BURLAPPED OR CONTAINER GROWN, UNLESS OTHERWISE NOTED ON THE PLANT LIST.
 3. THE CONTRACTOR SHALL SUPPLY ALL NEW PLANT MATERIAL IN QUANTITIES SUFFICIENT TO COMPLETE THE PLANTING SHOWN ON THE DRAWINGS.
 4. ANY PROPOSED SUBSTITUTIONS OF PLANT SPECIES SHALL BE MADE WITH PLANTS OF EQUIVALENT OVERALL FORM, HEIGHT, BRANCHING HABIT, FLOWER, LEAF, COLOR, FRUIT AND CULTURE, AND ONLY AFTER WRITTEN APPROVAL OF THE LANDSCAPE ARCHITECT.
 5. ALL NEW PLANTS SHALL BE TAGGED AND APPROVED BY THE LANDSCAPE ARCHITECT AT THE NURSERY PRIOR TO DIGGING OR DELIVERY TO THE SITE.
 6. CONTRACTOR SHALL LOCATE AND VERIFY ALL EXISTING UTILITY LINES PRIOR TO PLANTING AND SHALL REPORT ANY CONFLICTS TO THE LANDSCAPE ARCHITECT.
 7. STAKE LOCATIONS OF ALL PROPOSED PLANTING FOR APPROVAL BY THE LANDSCAPE ARCHITECT PRIOR TO THE COMMENCEMENT OF PLANTING. INDIVIDUAL STAKES SHALL BE PLACED FOR TREES AND SHRUBS. EDGE OF PLANTING BEDS SHALL BE PAINTED. NOTIFY LANDSCAPE ARCHITECT 24 HOURS PRIOR TO DESIRED APPROVAL.
 8. ALL NEW PLANTS SHALL BE SUPPLIED AND INSTALLED DURING THE PERIODS OF APRIL 1 - JUNE 15 AND/OR SEPTEMBER 1 - DECEMBER 1.
 9. PREPARE ALL SHRUB PLANTING BEDS TO A MINIMUM DEPTH OF EIGHTEEN INCHES (18") WITH SPECIFIED PLANTING MIX: 16" SCREENED LOAM, 2" COMPOST. BLEND COMPOST INTO TOP 4" OF SOIL. PLANTING MIX SHALL BE FREE OF SUBSOIL, LUMPS, STONES, PLANTS, ROOTS, AND OTHER FOREIGN MATTER.
 10. ALL SHRUB BEDS AND INDIVIDUAL TREE PITS SHALL RECEIVE THREE INCHES (3") OF BARK MULCH PER SPECIFICATIONS. PERENNIAL AND GROUND COVER BEDS SHALL RECEIVE TWO INCHES (2"). PROVIDE LANDSCAPE ARCHITECT WITH SAMPLE FOR APPROVAL.
 11. ALL BURLAP, TWINE AND WIRE SHALL BE COMPLETELY REMOVED OR CUT AWAY AT TIME OF INSTALLATION.
 12. PLANT WARRANTY SHALL BE FOR ONE FULL GROWING SEASON FROM THE TIME OF INSTALL.
 13. LANDSCAPE CONTRACTOR SHALL BE RESPONSIBLE FOR REPLACING ALL DAMAGED, STOLEN, DEAD, DECLINING OR LOST MATERIAL UNTIL COMPLETION OF MAINTENANCE PERIODS OR WARRANTY PERIODS.
 14. IF NO IRRIGATION SYSTEM IS PLANNED, CONTRACTOR SHALL INFORM OWNER OF WATERING REQUIREMENTS.
 15. ALL AREAS TO BE SEEDED OR SODDED SHALL RECEIVE SIX INCHES (6") OF LOAM, MEASURED AFTER INSTALLATION, PRIOR TO SEEDING.
 16. SEED MIXTURE SHALL BE RI BLACK BEAUTY MIX BY JONATHAN GREEN OR APPROVED EQUIV. 85% TALL TURF FESCUE, 15% KENTUCKY BLUE GRASS. 6.5LBS/1000SF
 17. PRUNE TREES IN ACCORDANCE WITH THE SPECIFICATIONS.
 18. ALL EXISTING LAWN AREAS DESIGNED TO REMAIN SHALL BE AERATED, FERTILIZED AND OVERSEEDED, AS DIRECTED BY THE LANDSCAPE ARCHITECT.
 19. IN ADDITION TO LOCATIONS DEFINED FOR SEED ON THE PLANTING PLAN, THE CONTRACTOR SHALL BE RESPONSIBLE FOR SEEDING ANY DISTURBED AREAS.
 20. ALL VEGETATION AND DEBRIS SHALL BE REMOVED FROM PROPOSED PLANTING AREAS PRIOR TO PLANTING AND BACKFILLING. CONTRACTOR SHALL REMOVE ALL DEBRIS FROM SITE AS WORK PROGRESSES.
 21. LANDSCAPE CONTRACTOR IS RESPONSIBLE FOR MAINTAINING CLOSE COORDINATION WITH OWNER, GENERAL CONTRACTOR, RELATED SUBCONTRACTORS, LANDSCAPE ARCHITECT, AND ALL SITE WORK RELATED ITEMS.

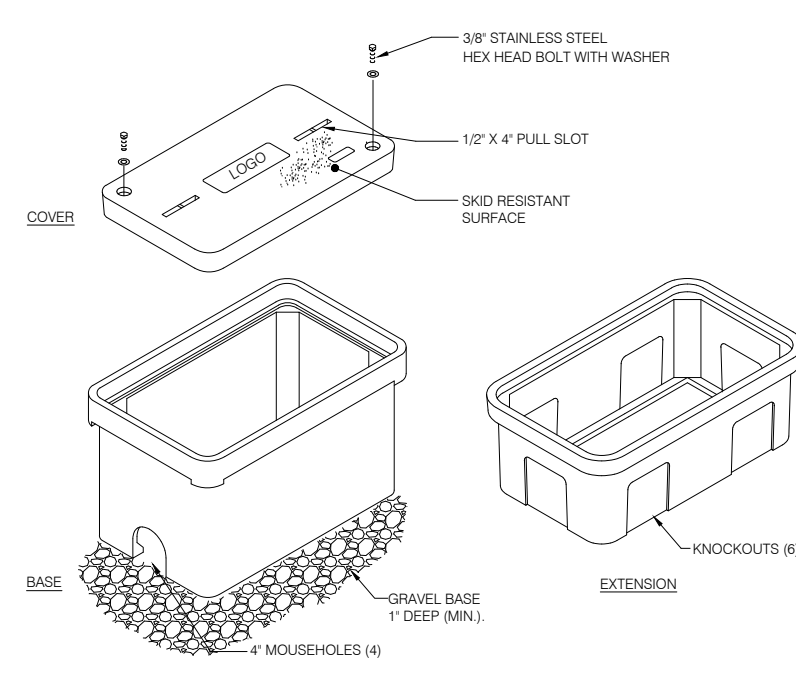

7 TYPICAL ELECTRICAL HANDHOLE DETAIL No Scale

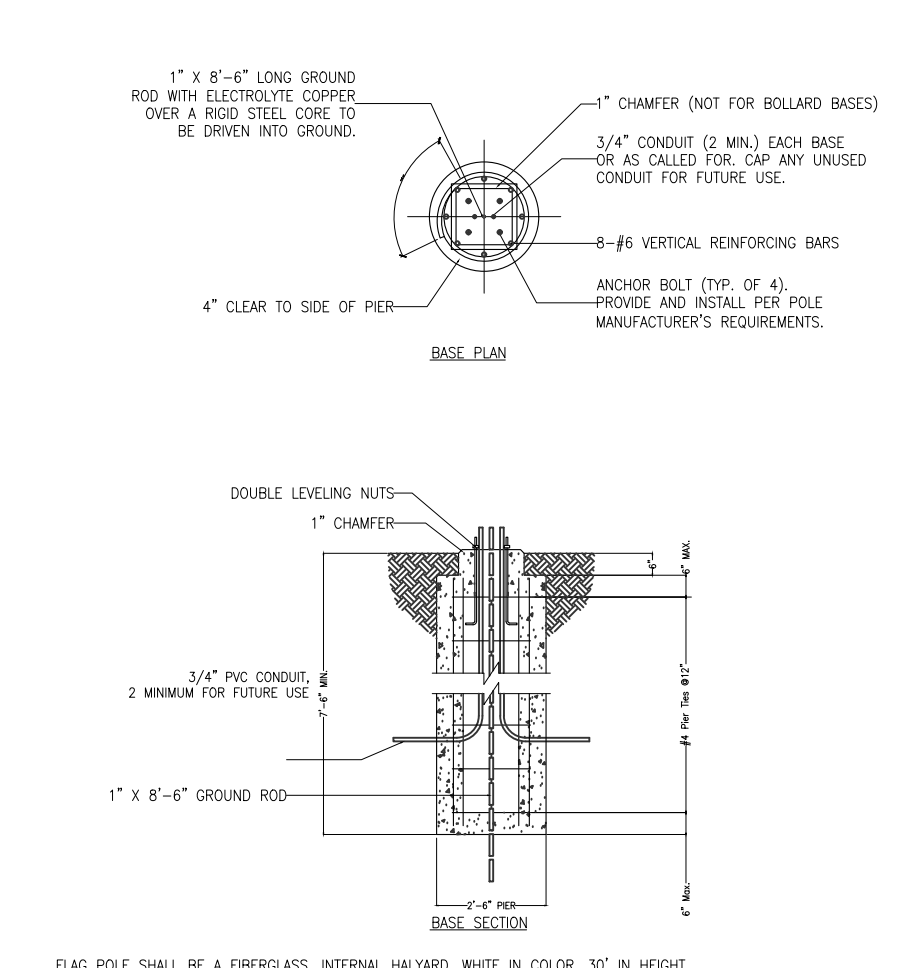

8 CONCRETE BASE FOR FLAG POLE ADD ALTERNATE #6 No Scale

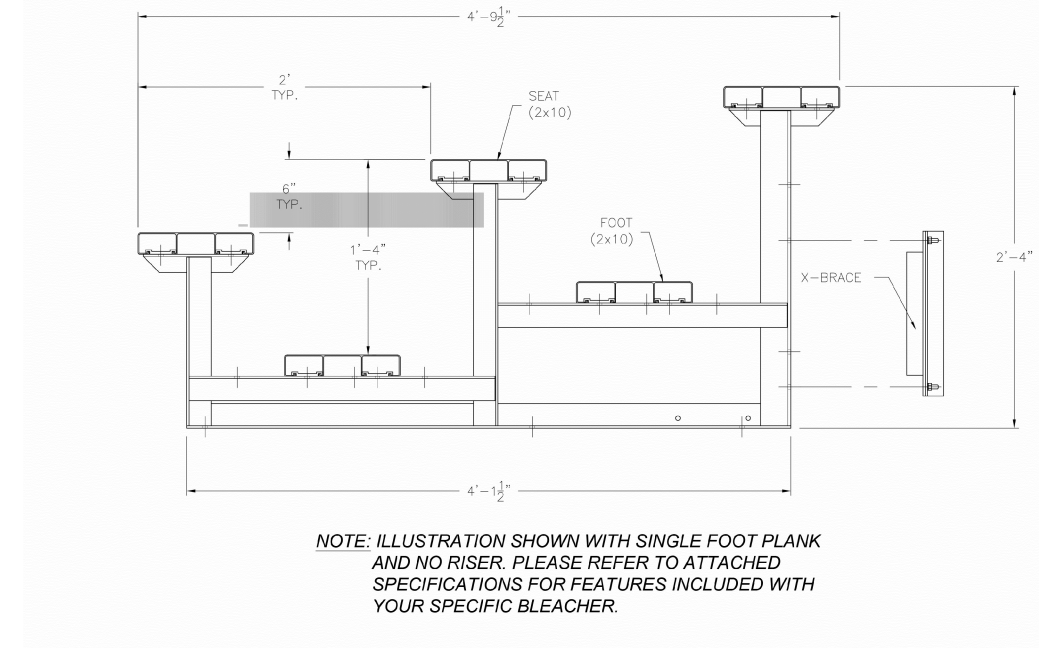

9 BLEACHER ADD ALTERNATE #5 No Scale

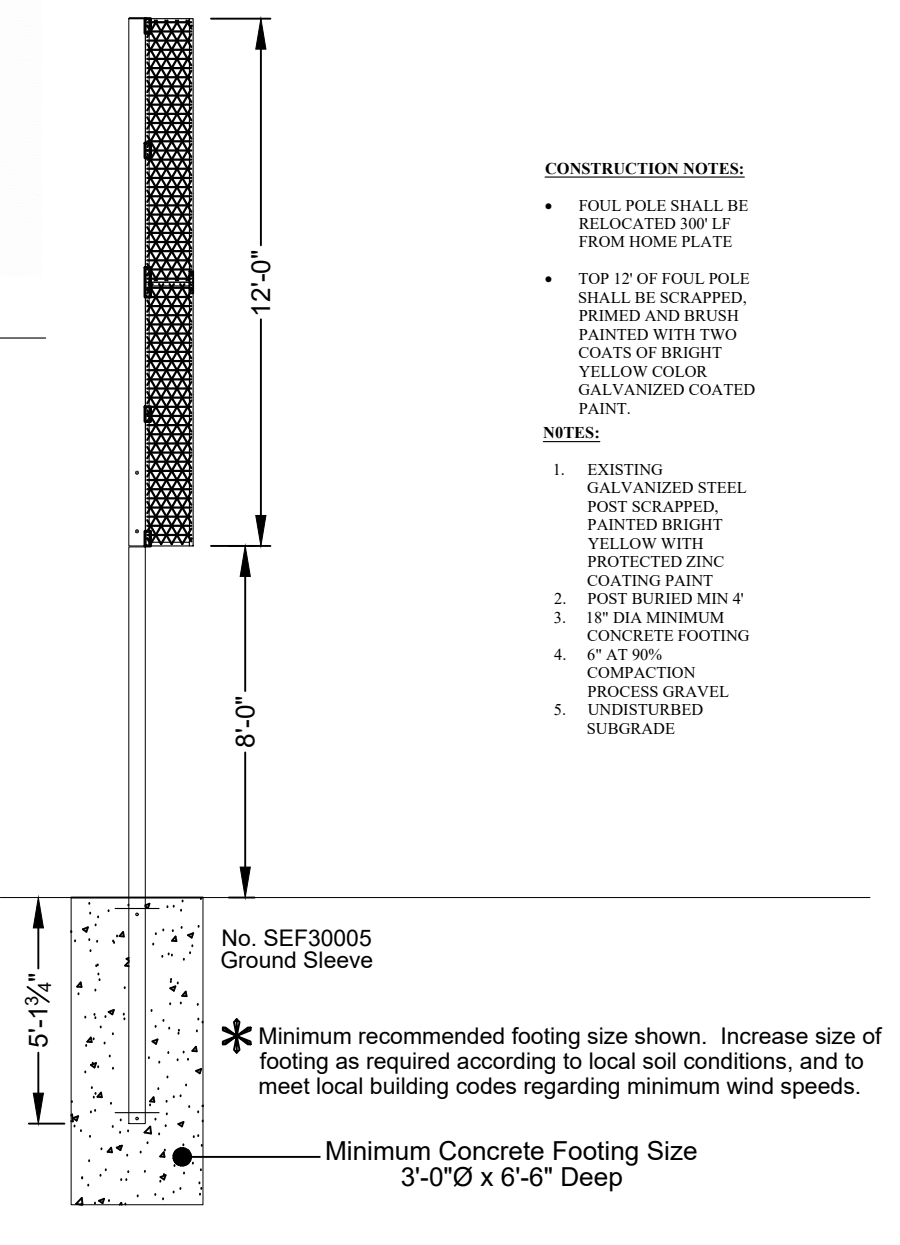

12 BASEBALL FOUL POLES (PAIR) In-Ground/Sleeve Mount ADD ALTERNATE #4 No Scale

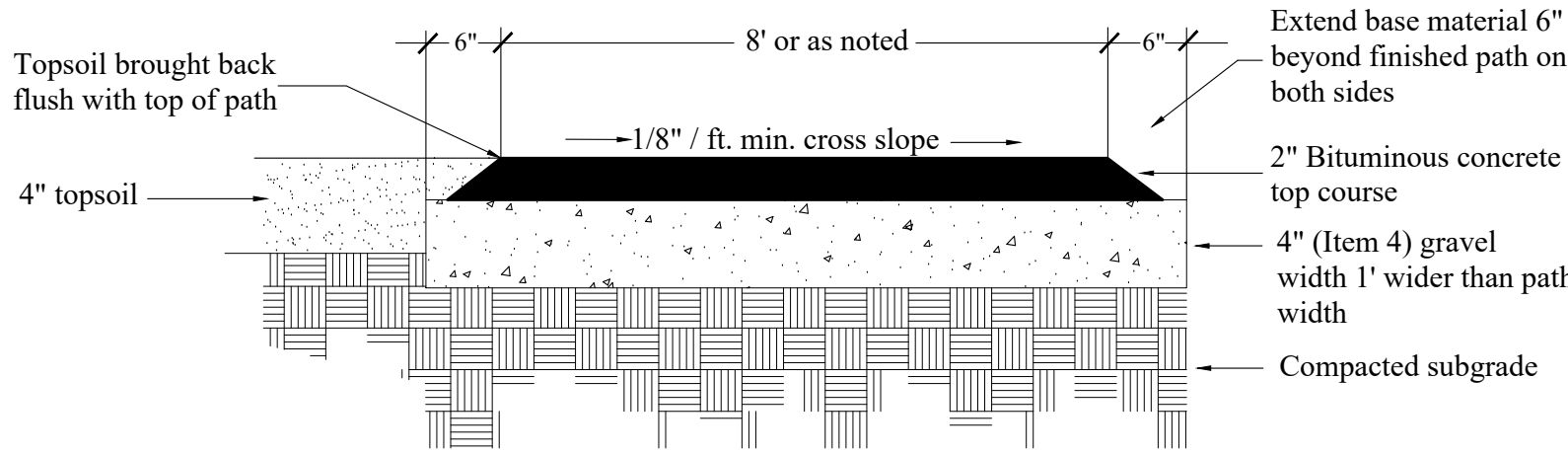

- NOTES**
1. Proposed Path shall be excavated to a depth of five inches (5") in areas where proposed DGA material will be installed.
 2. Compact DGA in four inch (4") lifts while at or near optimum moisture with a minimum of four passes of a vibratory roller operated at a speed not to exceed three miles per hour (3 MPH). The sub grade shall be proof rolled/compacted to create a proper level of compaction to 90% density.
 3. All material shall be machine laid. The thickness of Bituminous Concrete shall be the thickness as specified in the proposal after proper compaction. No material shall be laid when the temperature falls below 50 degrees Fahrenheit or the existing surface is wet or damp.

10 BITUMINOUS CONCRETE No Scale

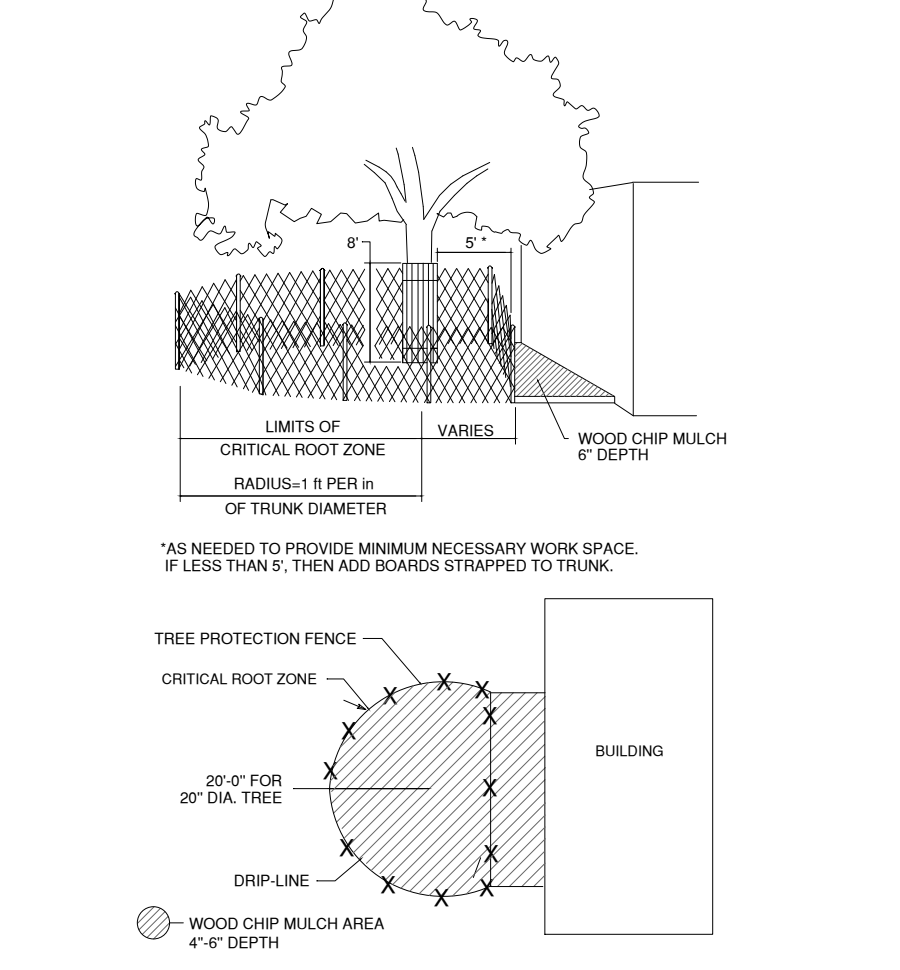

11 TREE PROTECTION No Scale

| NO. | REVISIONS | BY | DATE |
|-----|-----------|----|------|
| | | | |
| | | | |
| | | | |

Detail
Plan



PROVIDENCE PARKS DEPARTMENT
Collyer Park Improvements
Providence, Rhode Island

| | | | | |
|-------------|-----------|----------|-------------|----------|
| DESIGNED BY | DWG SCALE | 1" = 40' | CONTRACT NO | |
| DRAWN BY | TDG | | S/JC | |
| CHECKED BY | | | DATE | 09.29.21 |
| TDG | | | | |

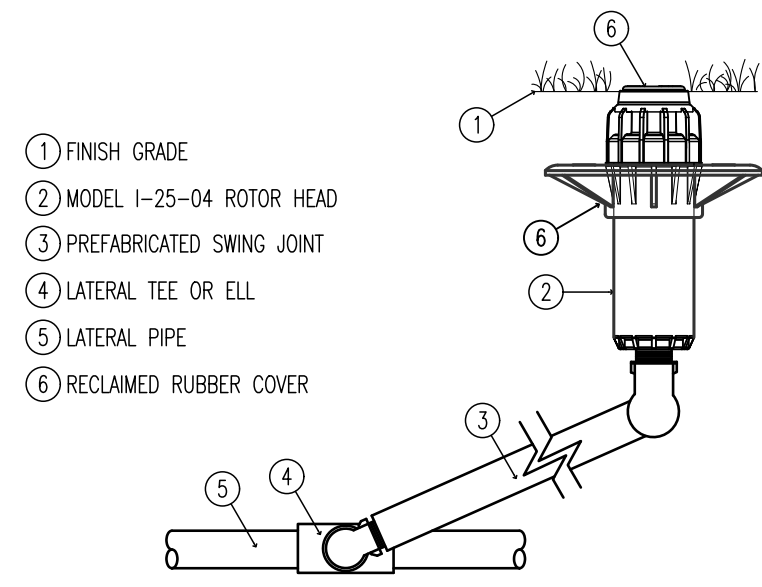

- 1 FINISH GRADE
- 2 MODEL I-25-04 ROTOR HEAD
- 3 PREFABRICATED SWING JOINT
- 4 LATERAL TEE OR ELL
- 5 LATERAL PIPE
- 6 RECLAIMED RUBBER COVER

NOTE: 4 SPRINKLERS ARE STAINLESS STEEL SHAFTS I-25 SS

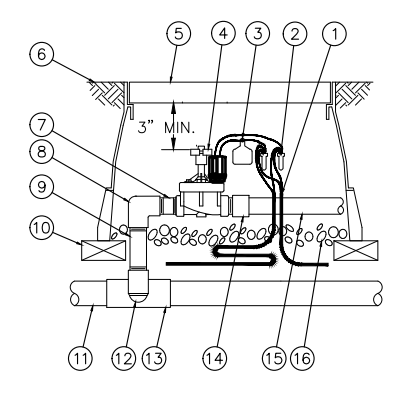

NOTE:
1. COIL AN ADDITIONAL 3'-FEET OF TWO-WIRE CABLE IN VALVE BOX FOR EASY SERVICING.

- 1 TWO-WIRE CABLE
- 2 WATERPROOF SPLICE CONNECTION RAIN BIRD W20 (TWO REQUIRED)
- 3 ID TAG
- 4 REMOTE CONTROL VALVE: RAIN BIRD PEB/PESB/PESB-R WITH W-STD
- 5 VALVE BOX WITH COVER: RAIN BIRD VB-STD
- 6 FINISH GRADE/TOP OF MULCH
- 7 PVC SCH 80 CLOSE NIPPLE
- 8 PVC SCH 80 ELL
- 9 PVC SCH 80 NIPPLE (LENGTH AS REQUIRED)
- 10 BRICK (1 OF 4)
- 11 PVC MAINLINE PIPE
- 12 SCH 80 NIPPLE (2-INCH LENGTH, HIDDEN) AND SCH 80 ELL
- 13 PVC SCH 80 TEE OR ELL
- 14 PVC SCH 40 MALE ADAPTER
- 15 PVC LATERAL PIPE
- 16 3-INCH MINIMUM DEPTH OF 3/4-INCH WASHED GRAVEL

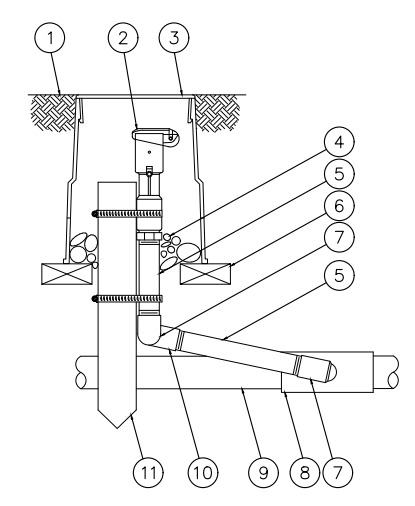

NOTE:
FURNISH FITTINGS AND PIPING NOMINALLY SIZED IDENTICAL TO NOMINAL QUICK COUPLING VALVE INLET SIZE.

- 1 FINISH GRADE/TOP OF MULCH
- 2 QUICK-COUPLING VALVE: RAIN BIRD MODEL 44RC
- 3 VALVE BOX WITH COVER: RAIN BIRD VB-66RD
- 4 3-INCH MINIMUM DEPTH OF 3/4-INCH WASHED GRAVEL
- 5 PVC SCH 80 NIPPLE (LENGTH AS REQUIRED)
- 6 BRICK (1 OF 2)
- 7 PVC SCH 40 STREET ELL
- 8 PVC SCH 40 TEE OR ELL
- 9 PVC MAINLINE PIPE
- 10 PVC SCH 40 ELL
- 11 2" x 2" REDWOOD STAKE WITH STAINLESS STEEL SEAL CLAMPS OR EQUIVALENT SUPPORT SYSTEM

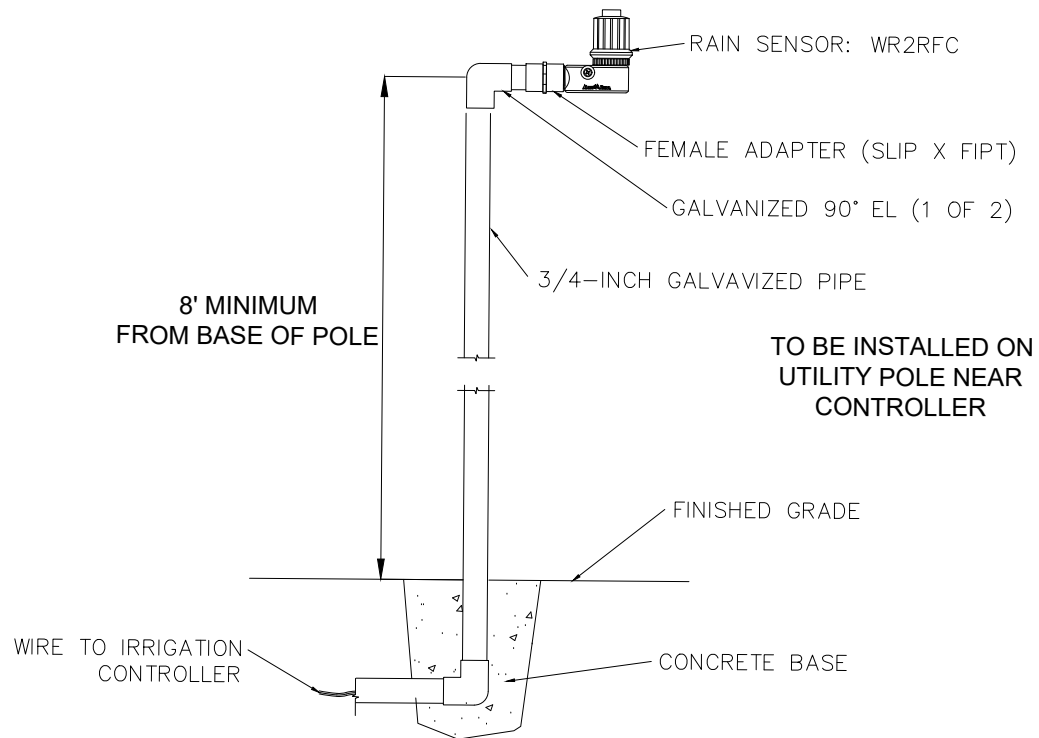

4 WIRELESS RAIN SENSOR DETAIL No Scale

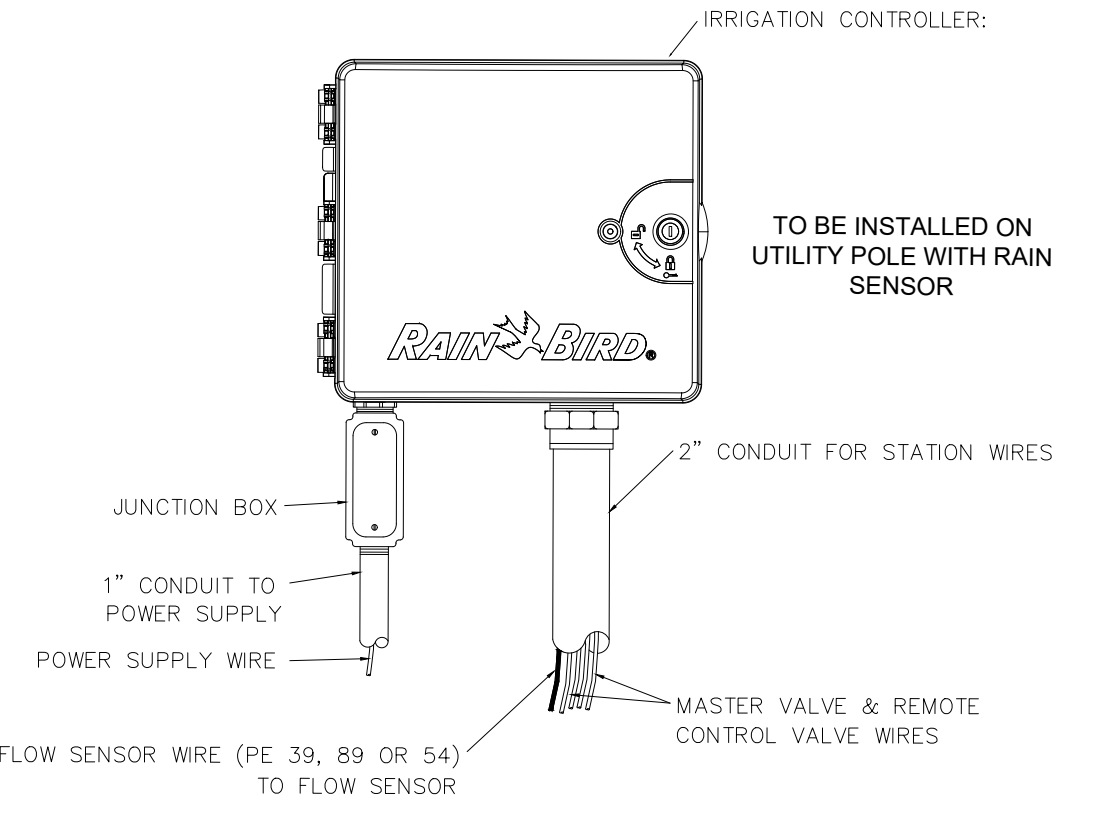

5 IRRIGATION CONTROLLER DETAIL WALL MOUNT EXTERIOR No Scale

1 HUNTER SPRINKLER I-25 No Scale

2 ELECTRIC REMOTE-CONTROL VALVE PEB SERIES No Scale

3 QUICK COUPLING VALVE MODEL 44RC SERIES No Scale

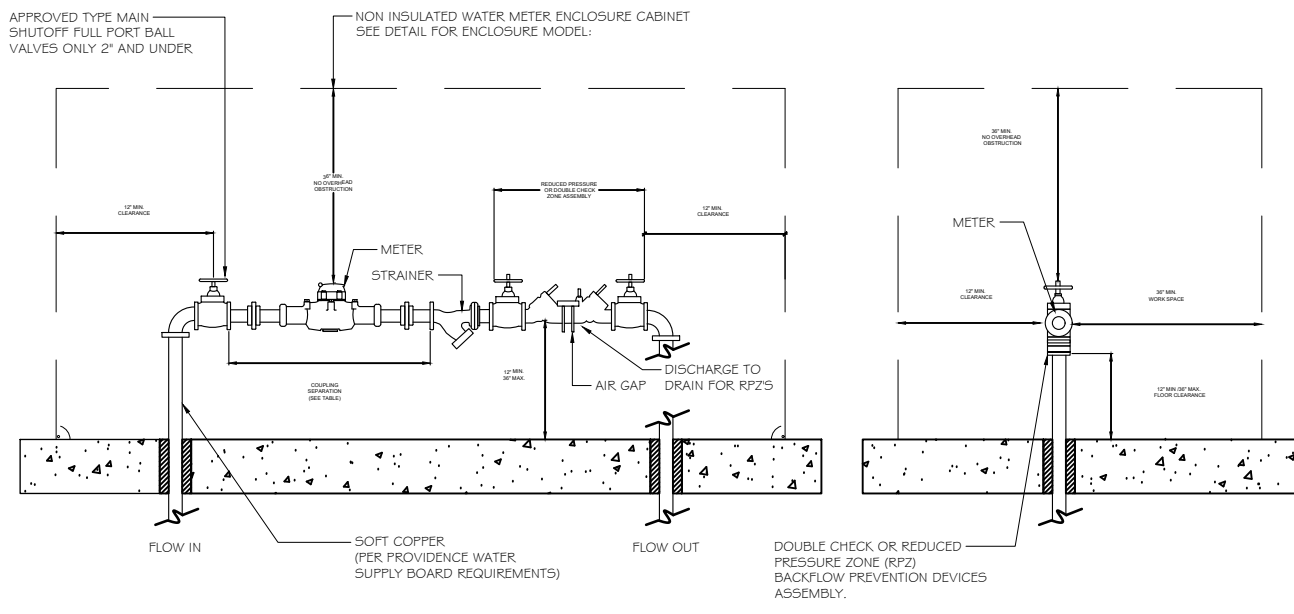

| WATER METER (INCHES) | COUPLING SEPARATION (FRANKE PIPE THREAD TO FRANKE PIPE THREAD) (INCHES) |
|----------------------|---|
| 3/4" | 1.250 |
| 1" | 1.500 |
| 1 1/4" | 1.750 |
| 1 1/2" | 2.000 |
| 2" | 2.500 |

NOTE:
TEST LOCKS MAY OR MAY NOT BE REQUIRED DEPENDING ON TYPE OF METER.
ROUTING IN METER AND BACKFLOW ASSEMBLY NOT ALLOWED. MUST BE ACCESSIBLE AT ALL TIMES.
CONTRACTOR SHALL CARRY ALL COST FOR FEES AND CHARGES BY PROVIDENCE WATER SUPPLY BOARD.
COST ASSOCIATED WITH TRAFFIC CONTROL SHALL BE PAID FOR BY THE CONTRACTOR.

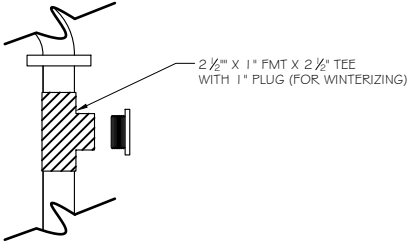

6 HORIZONTAL INS RPZ AND DOUBLE CHECK VALVE BACKFLOW No Scale

7 ALUMINUM BACKFLOW ENCLOSURE LOW PROFILE No Scale

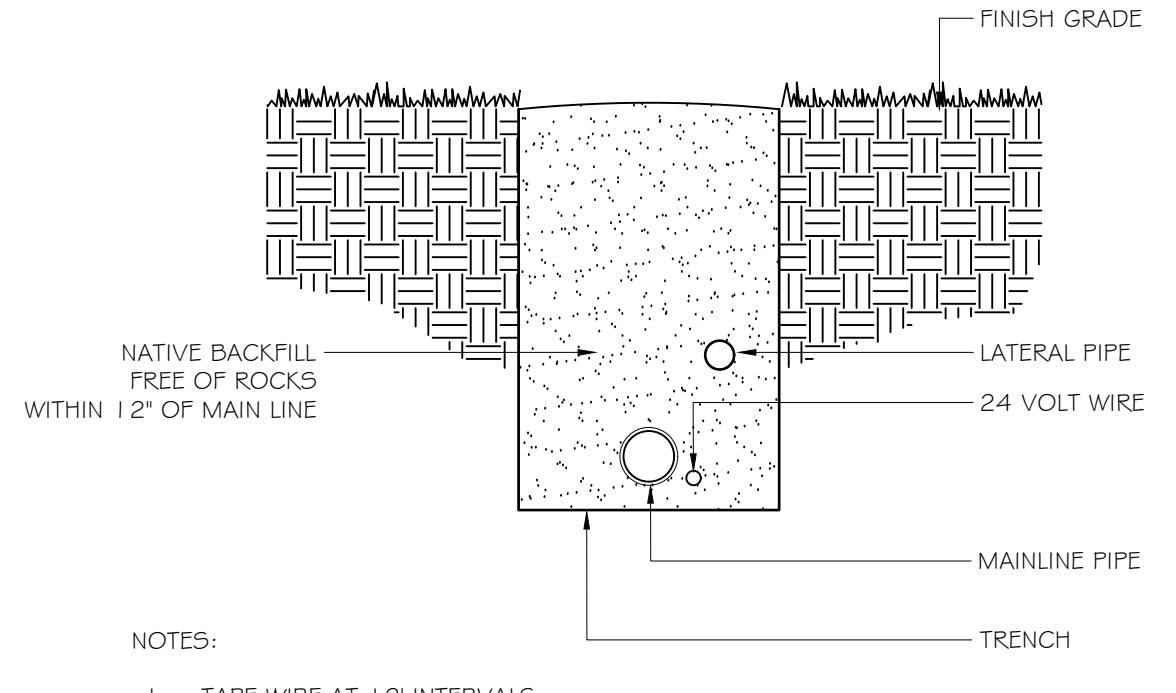

- NOTES:
1. TAPE WIRE AT 12" INTERVALS
 2. TIE LOOSE LOOP OF WIRE AT CHANGES OF DIRECTION

8 MAIN LINE TRENCH No Scale

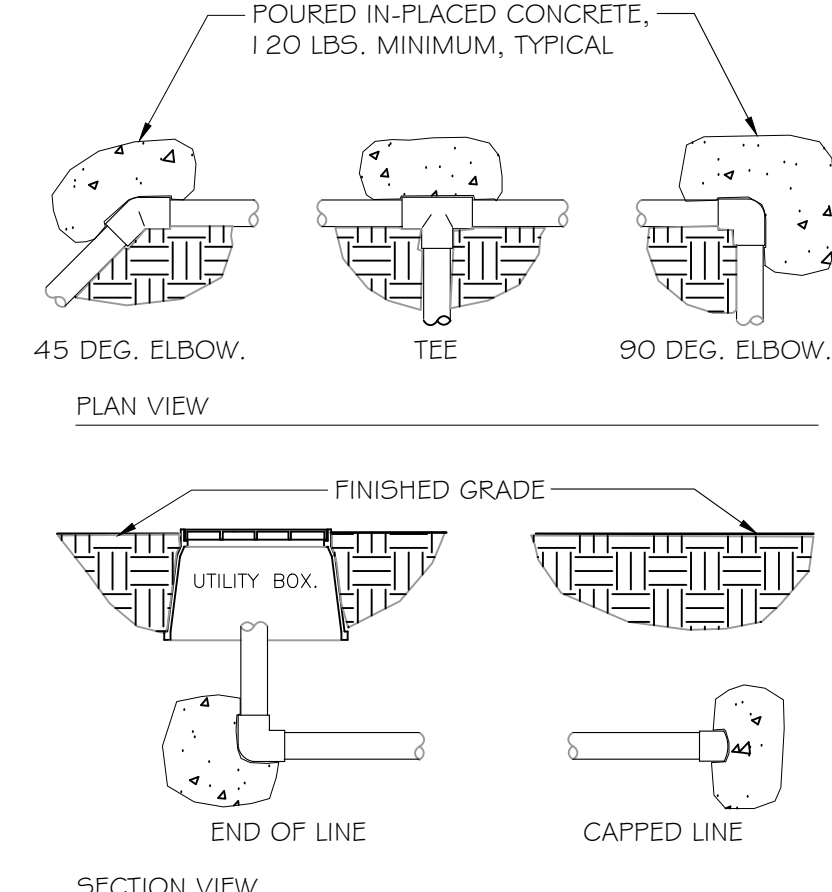

9 TRUST BLOCK No Scale

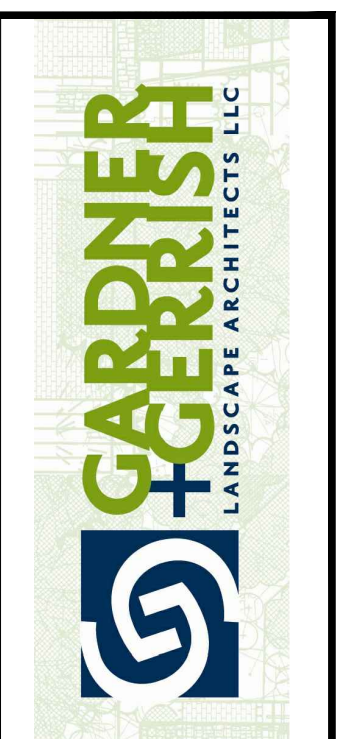

| NO. | REVISIONS | BY | DATE |
|-----|-----------|----|------|
| | | | |
| | | | |
| | | | |

Detail Plan

P
PROVIDENCE PARKS DEPARTMENT
Collyer Park Improvements
Providence, Rhode Island

| | | | |
|-------------|-----|-------------|----------|
| DESIGNED BY | TDG | DWG SCALE | 1" = 40' |
| DRAWN BY | SJC | CONTRACT NO | |
| CHECKED BY | TDG | DATE | 09.29.21 |

I-2