

NOTE:
1. DISTANCE TO I-95 STATE HIGHWAY ON-RAMP NOT FIELD VERIFIED

SURVEY CLASSIFICATION:

THIS SURVEY HAS BEEN CONDUCTED AND THE PLAN HAS BEEN PREPARED PURSUANT TO SECTION 9 OF THE RULES AND REGULATIONS ADOPTED BY THE RHODE ISLAND STATE BOARD OF REGISTRATION FOR PROFESSIONAL LAND SURVEYORS ON NOVEMBER 25, 2015, AS FOLLOWS:

TYPE OF BOUNDARY SURVEY: MEASUREMENT SPECIFICATION:
LIMITED CONTENT BOUNDARY SURVEY CLASS I

THE PURPOSE FOR THE CONDUCT OF THE SURVEY AND FOR THE PREPARATION OF THE PLANS AS FOLLOWS:
TO ESTABLISH AND STAKE RECORD BOUNDARY LINES.

BY: *[Signature]* DATE: Nov 5, 2020
RICHARD T. BZDYRA, PLS: LICENSE #1786, COA # I.S-A60

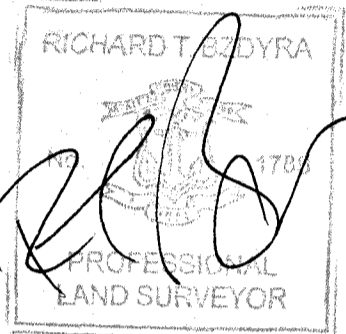

R.I. DEPARTMENT OF PUBLIC WORKS
FREEWAY No. 47
PLAT 1265 / SHEET 3 of 5

HIGHWAY DETAIL
NOT TO SCALE

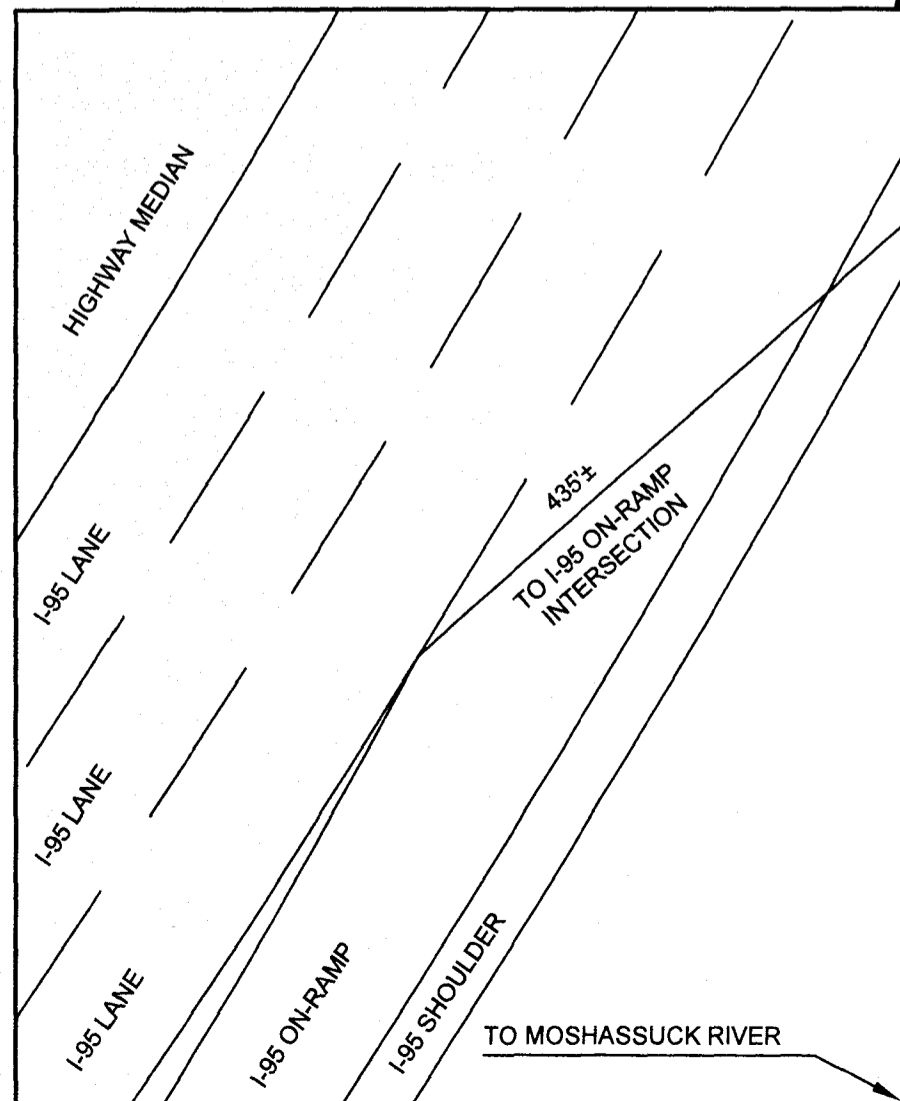

A.P. 2 / LOT 340
N/F
RAB PROPERTIES, LLC.

A.P. 2 / LOT 447
N/F
NM REALTY, LLC.

A.P. 2 / LOT 611
N/F
AMERICAN
MATHEMATICAL
SOCIETY

A.P. 2 / LOT 619
N/F
CHARLES GATE NURSING CENTER

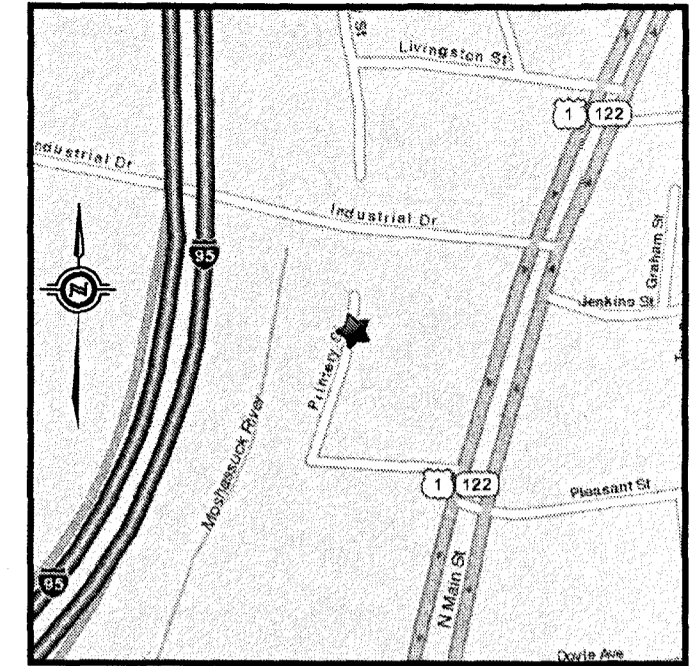
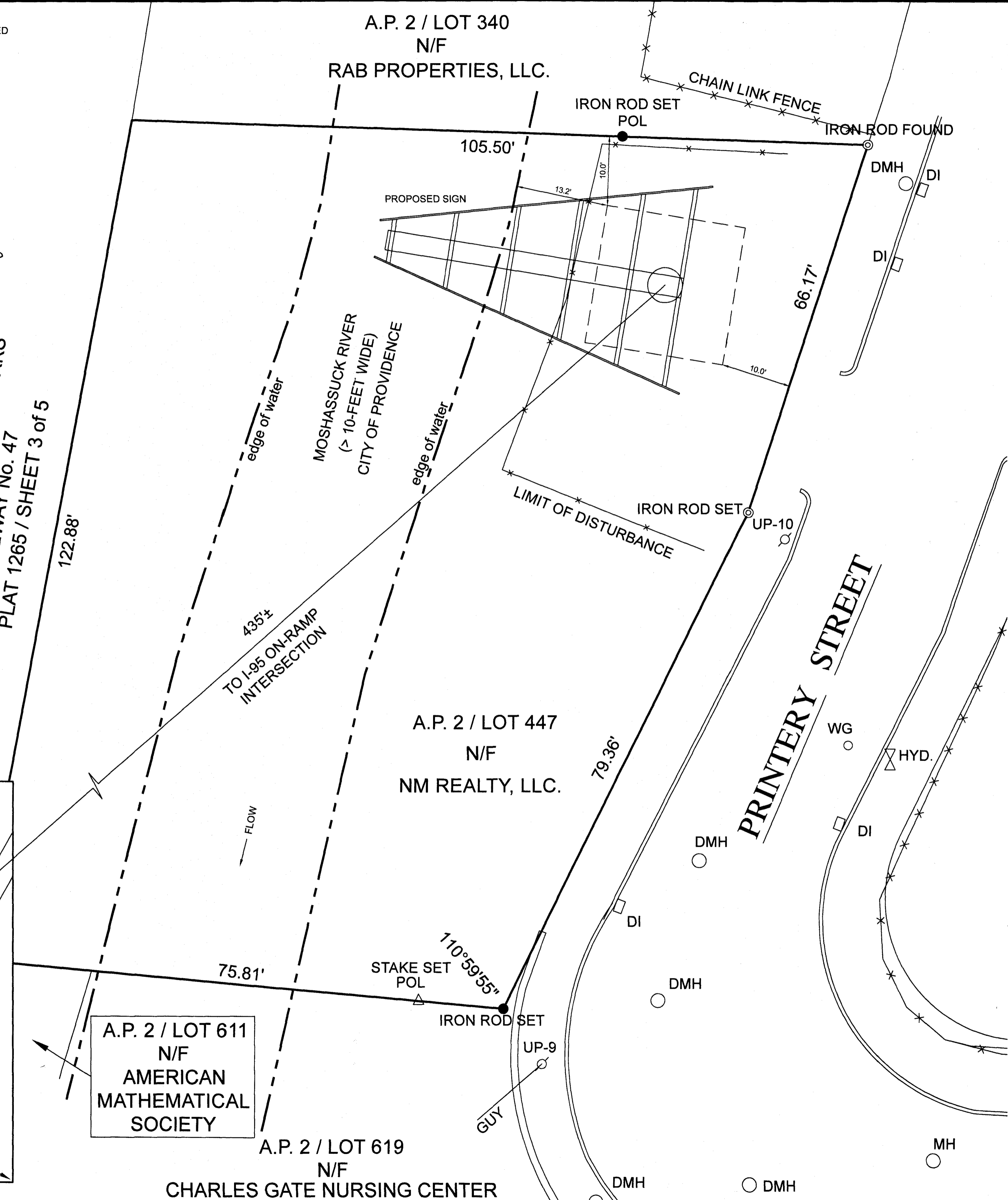

LOCUS MAP
NOT TO SCALE

ZONING DISTRICT C-3

MINIMUM LOT AREA NONE
MINIMUM LOT FRONTAGE NONE
MINIMUM SETBACKS: FRONT NONE
SIDE NONE
CORNER SIDE NONE
REAR NONE
MAXIMUM BUILDING & IMPERVIOUS SURFACE COVERAGE: NONE
MAXIMUM BUILDING HEIGHT: 50' NOT TO EXCEED 4 STORIES.
MINIMUM FIRST STORY HEIGHT 9' RES. 11' NON-RES USE
MINIMUM BUILDING HEIGHT NONE

PROPOSED BILLBOARD SIGN PLAN

A.P. 2 / LOT 447
58 PRINTERY STREET
PROVIDENCE, R.I.
SCALE: 1"=10' DATE: MAY 4, 2011
REVISION: OCTOBER 28, 2020 (AJB)
PREPARED FOR:
CAPITAL ASSOCIATES, INC.
PO BOX 590556, NEWTON CENTER, MA 02459
PHONE: (617) 797-4235

PREPARED BY:
OCEAN STATE PLANNERS, INC.
1255 OAKLAWN AVENUE, CRANSTON, RI 02920
PHONE: (401) 463-9696 FAX: (401) 463-9039

JOB NO. 7582 / DWG. NO. 7582 - (JNP)



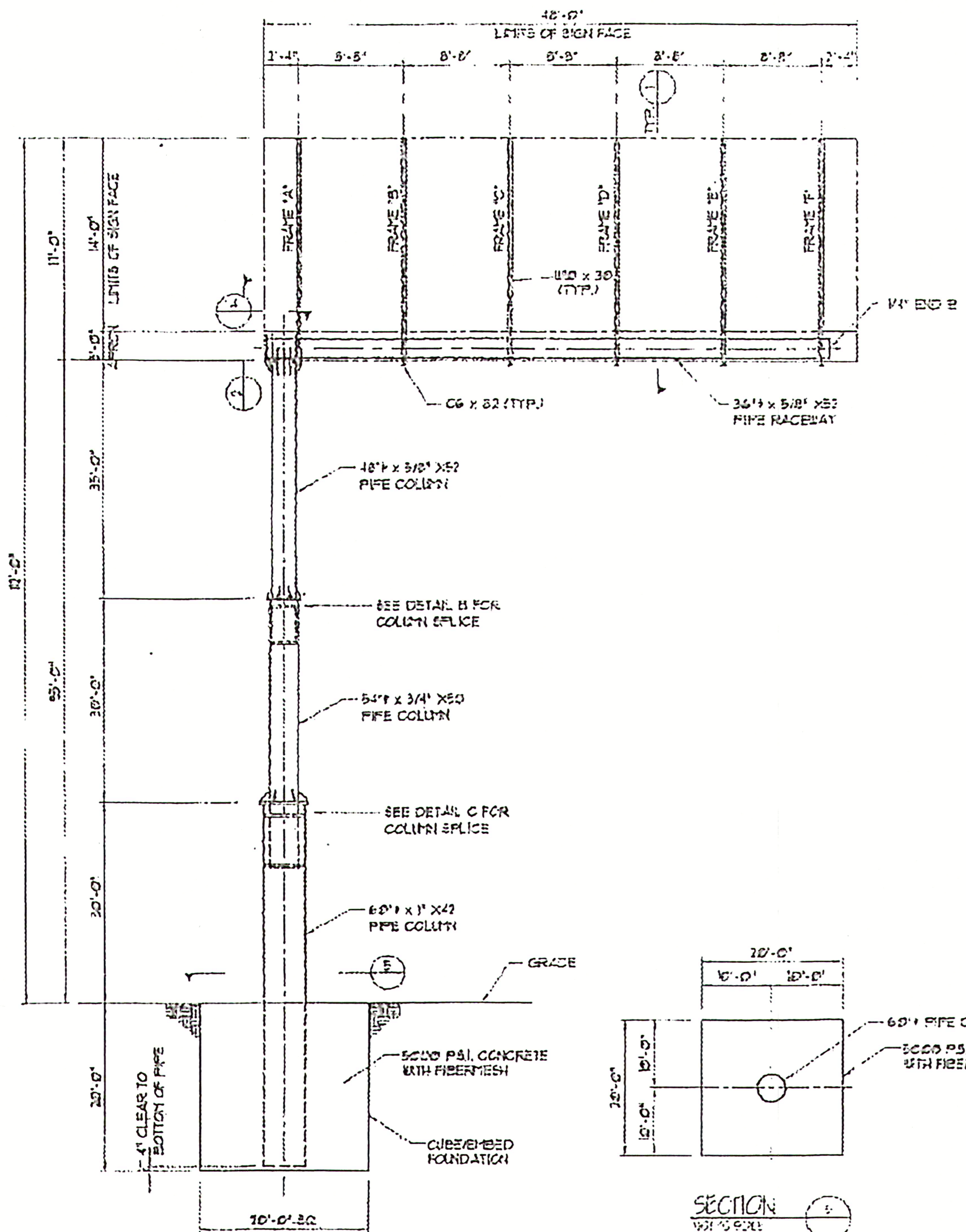

SIGN FRAME ELEVATION
NOT TO SCALE

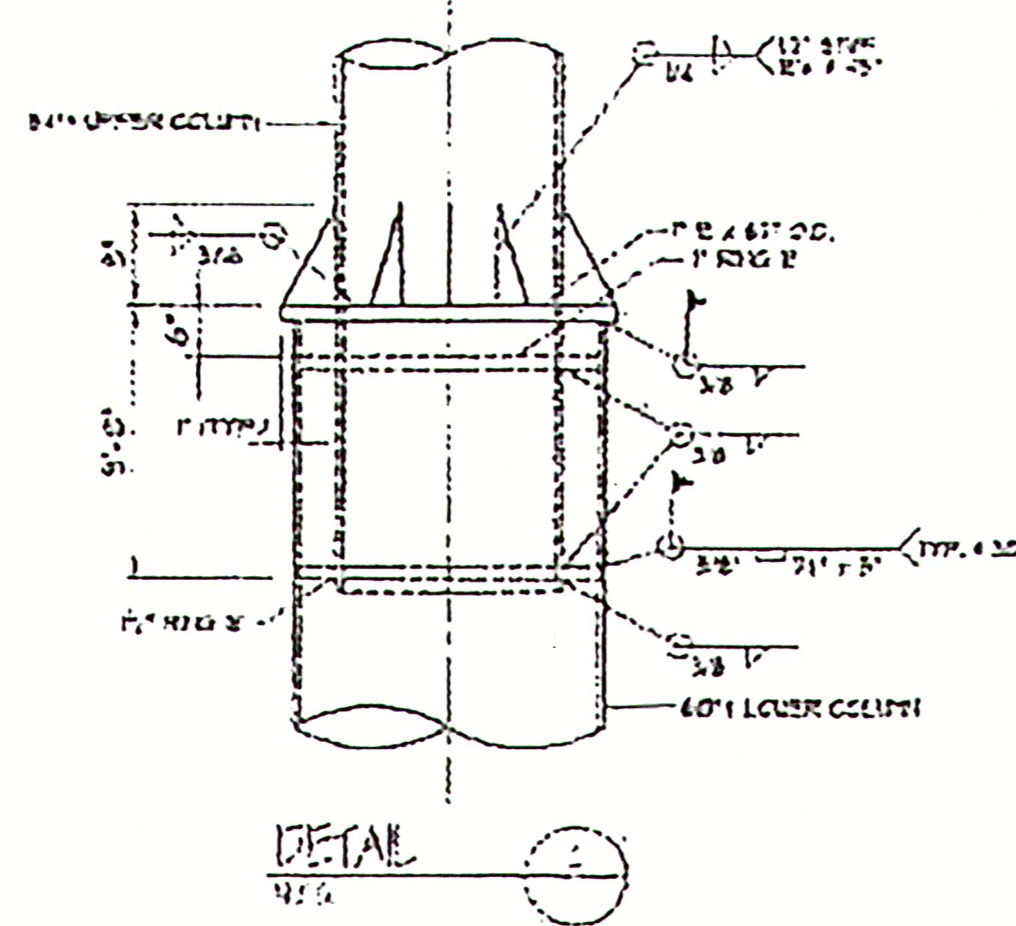
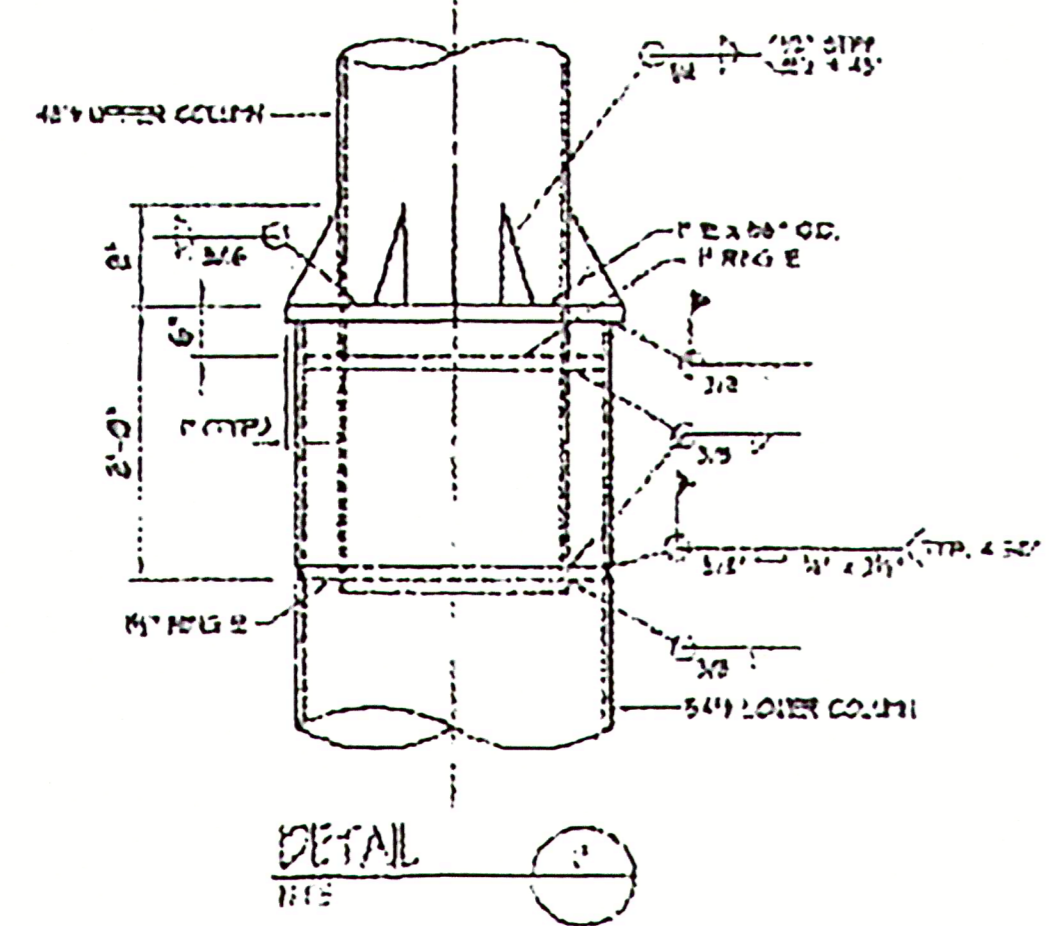

28'-10 1/2"	FRAME 'A'
24'-0 1/2"	FRAME 'B'
25'-1"	FRAME 'C'
15'-5 1/4"	FRAME 'D'
11'-3 1/4"	FRAME 'E'
9'-6 1/4"	FRAME 'F'

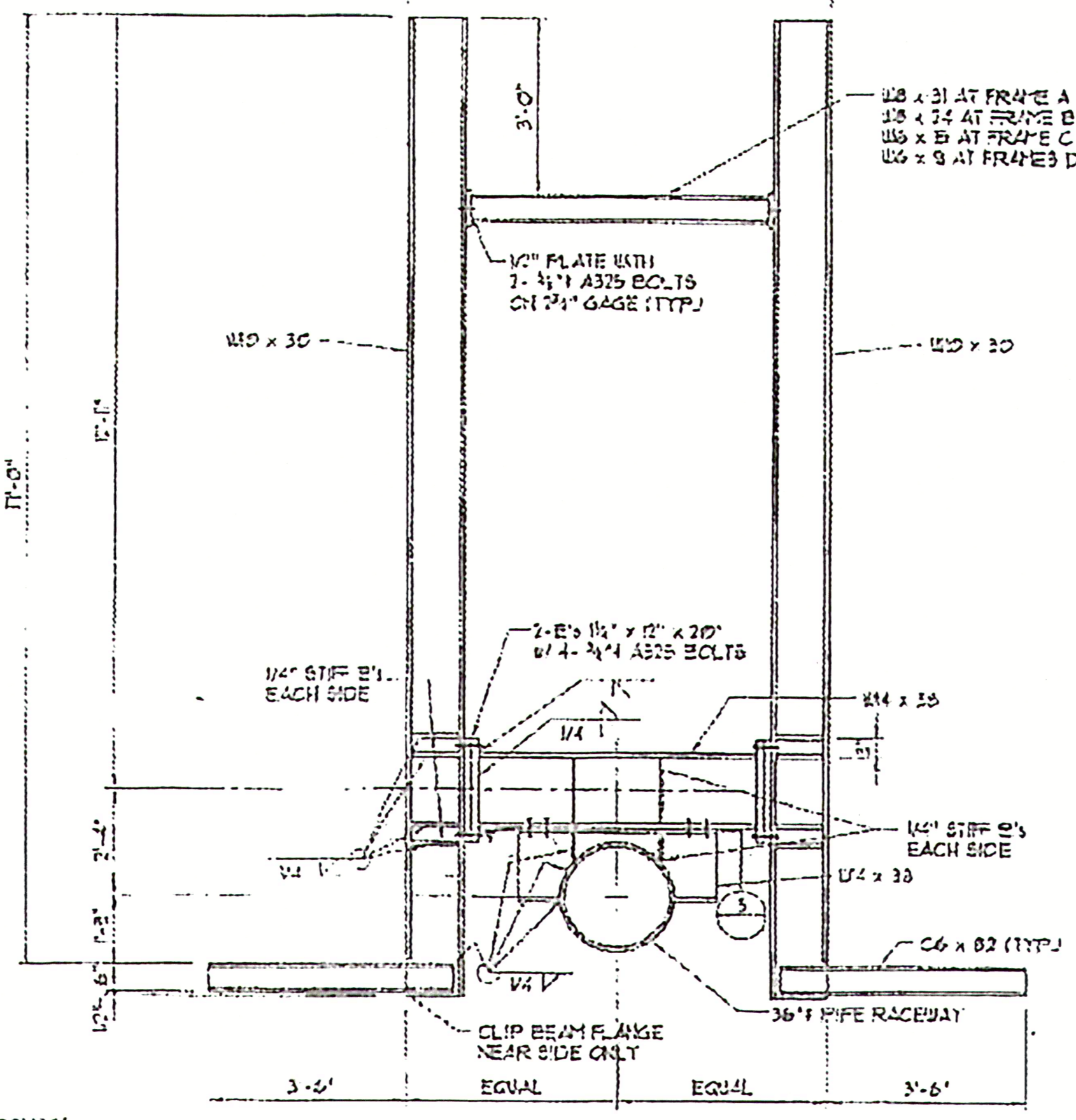

SECTION 2
TYPICAL

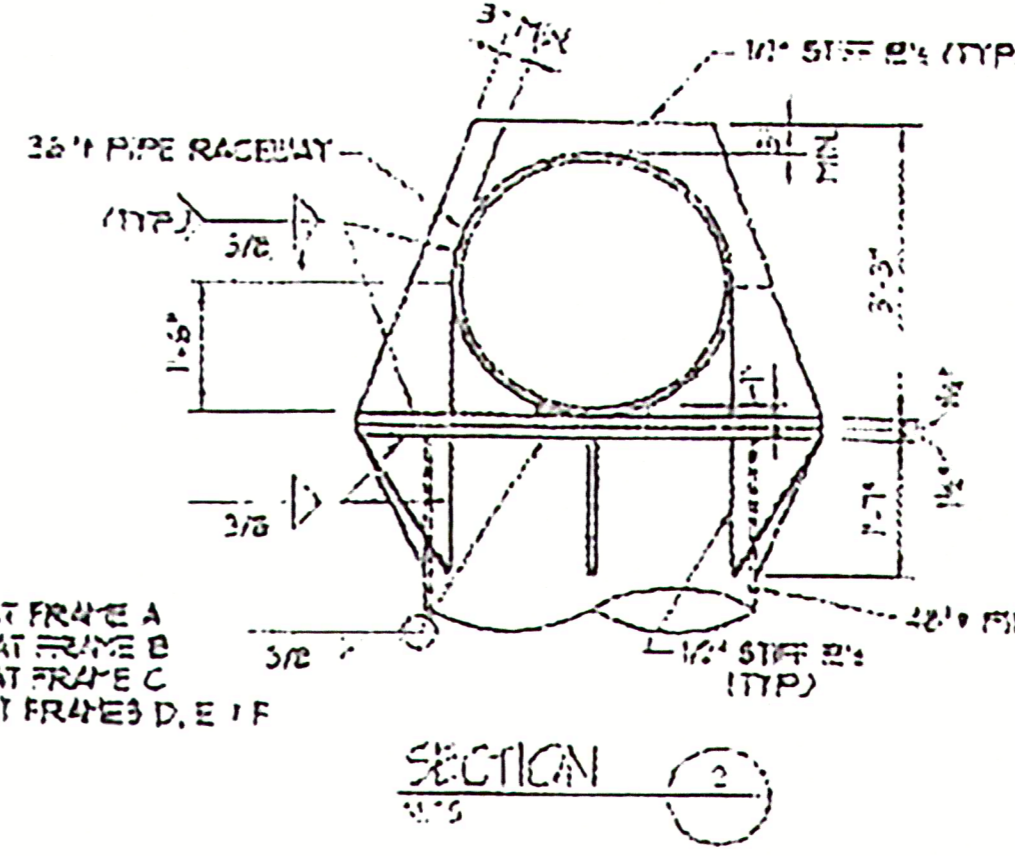

SECTION 3
TYPICAL

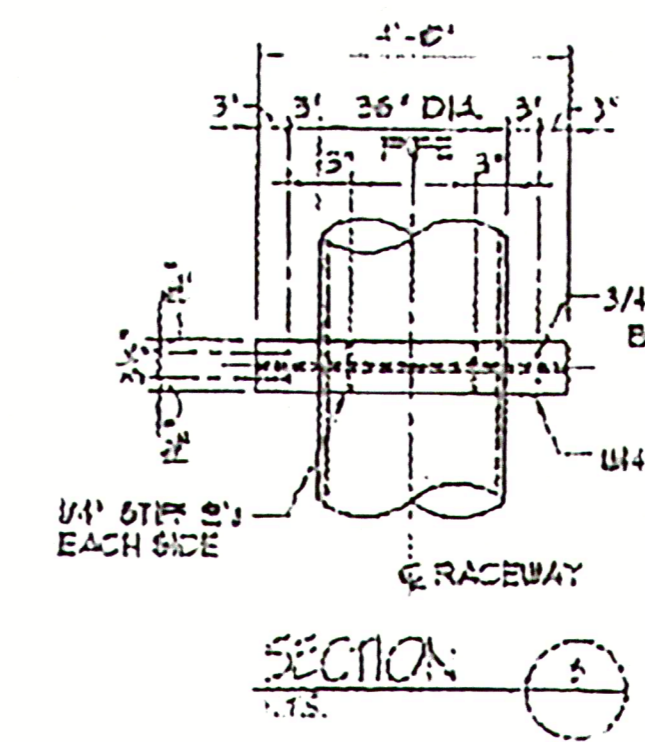

SECTION 4
TYPICAL

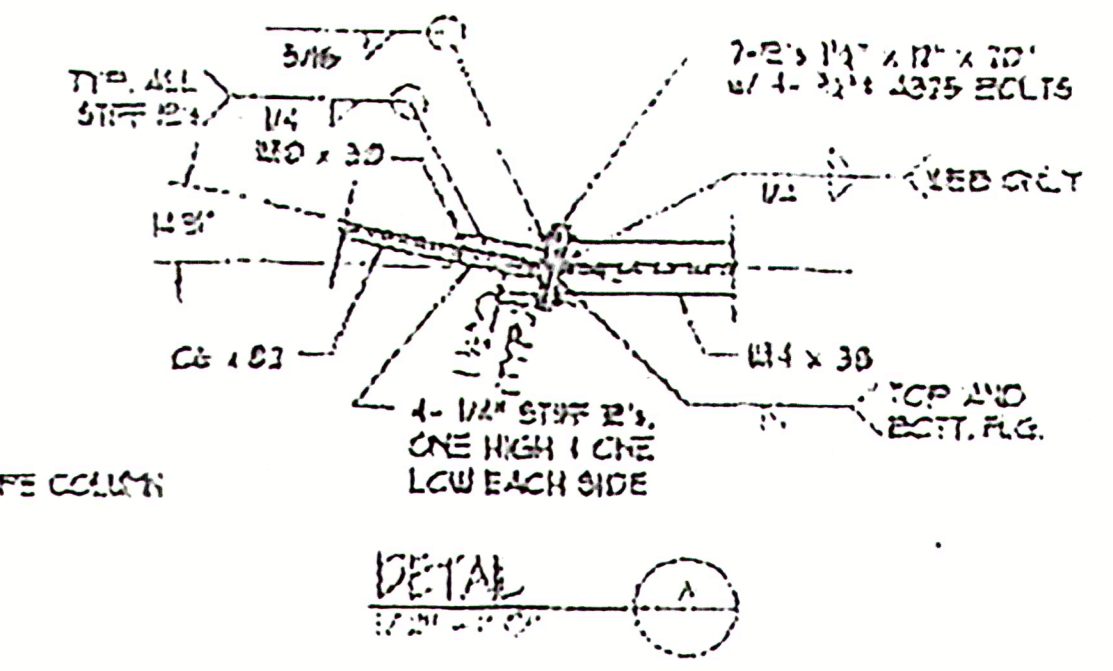

DETAIL A
TYPICAL

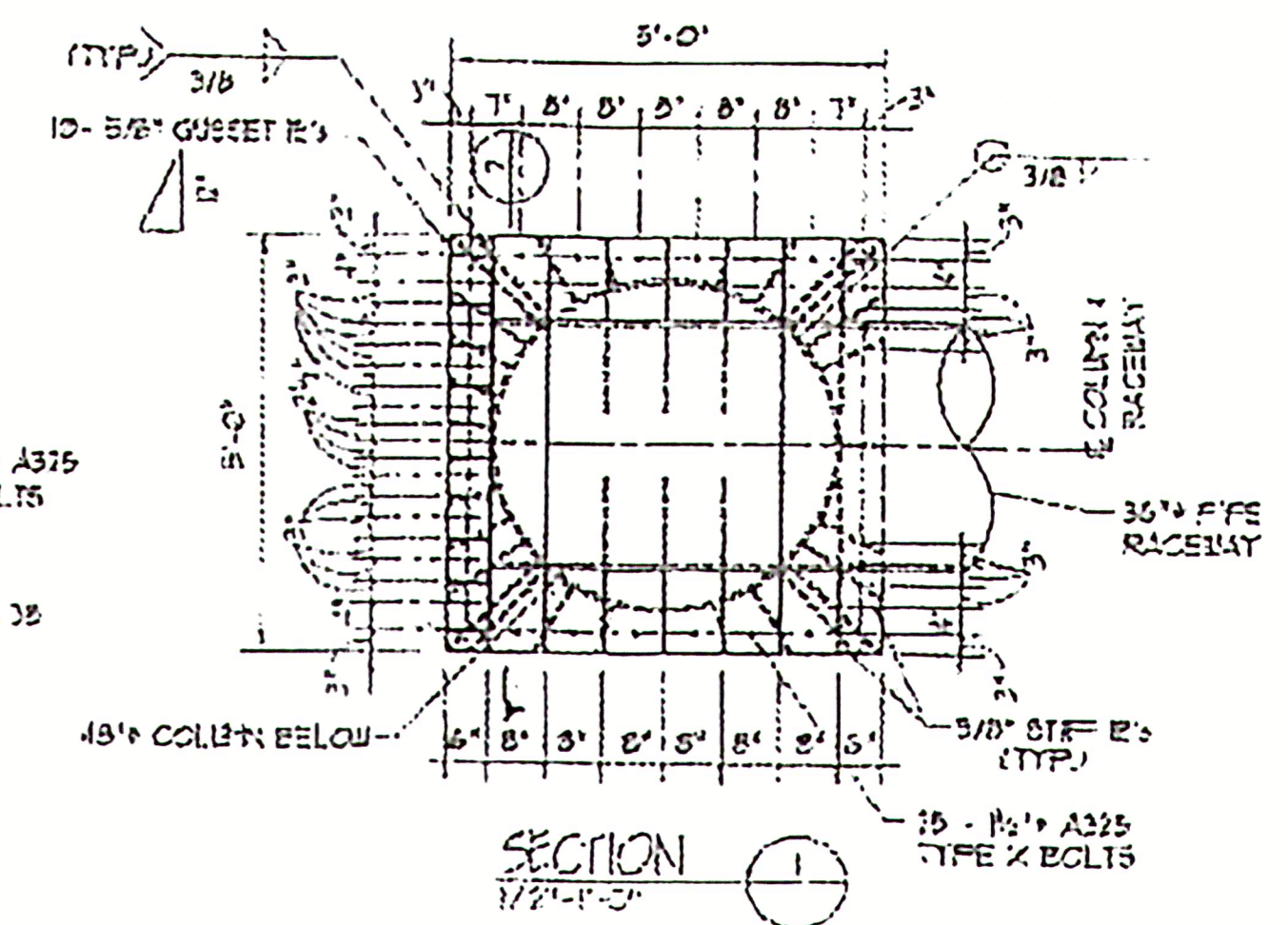

SECTION 1
TYPICAL

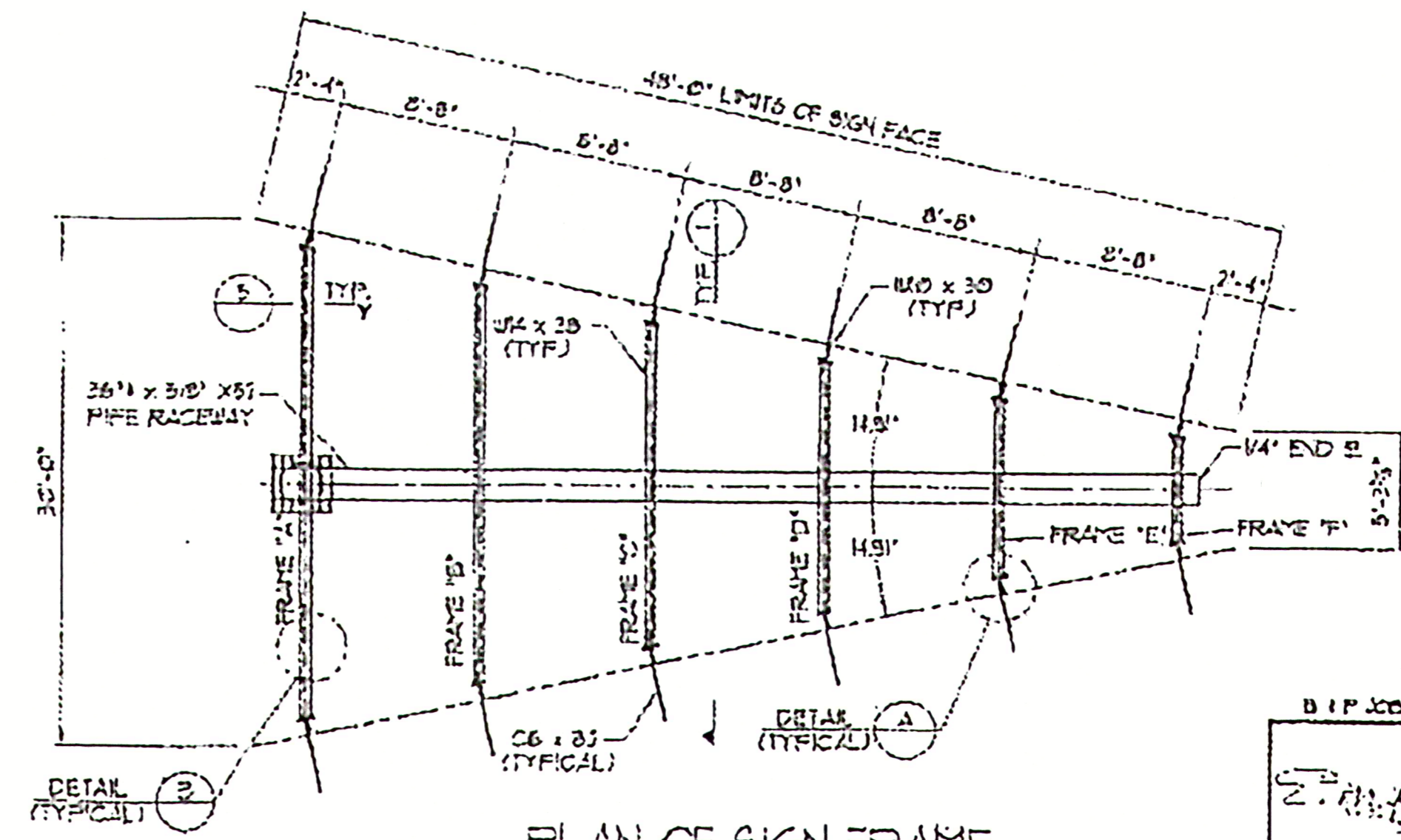

PLAN OF SIGN FRAME
NOT TO SCALE (30" VEE SIGN FACE)

NOTES:

1. ALL BOLTS 3/4" A325 GALVANIZED UNO.
2. DESIGN WIND LOAD 110 MPH, EXPOSURE 'C' PER FLORIDA STATE BUILDING CODE (2006 INTERNATIONAL BUILDING CODE).
3. ALL STEEL SHALL BE ASTM A-36 UNLESS NOTED. WIDE FLANGES SHALL BE A991-50.
4. MAXIMUM SIGN FACE AREA 1000 SQUARE FEET.
5. ALL WELDS SHALL BE MADE BY AN AWS CERTIFIED WELDER USING E70 FILLER MATERIAL.
6. MINIMUM LATERAL PASSIVE SOIL BEARING CAPACITY SHALL BE 400 P.S.F. PER FOOT OF DEPTH.

PRINTED
JUN 9 2008

B. P. JOHNSON, INC.	
OUTDOOR SPECIALIST, INC. Augusta, Georgia	
scale: NOTED	revision: _____
date: 6/2/08	by: dsl
drawn: TED	
chkd: TPL	
SIGN FRAME #2409-051	

58-306
08 1723
7581