



### Record No: ZBR-26-24

Zoning Board of Review Application

Status: Active

Submitted On: 6/10/2026

### Primary Location

612 Academy Ave  
Providence, RI 02908

### Owner

Lasalle Academy

[Redacted]  
[Redacted]

### Applicant

Hipolito Aguilera

[Redacted]

[Redacted]

[Redacted]

[Redacted]  
[Redacted]

## Owners and Applicants Information

Who is Submitting this Application?\*

Other

Name and Professional Title of Person Submitting the Application\*

Patrick Meehan, Chief Financial Officer

Owners Name\*

St. John Baptist De La Salle Institute

Owner Mailing Address\*

[Redacted]  
[Redacted]

Owner Email\*

[Redacted]

Owner Phone\*

[Redacted]

Name of Applicant, if different than owner ?

Applicant Mailing Address, if different than owner

Applicant Email, if different than owner

Applicant Phone, if different than owner

Attorney Name

John J. Garrahy

Attorney Mailing Address

[Redacted]

Attorney Email

[REDACTED]

Attorney Phone

[REDACTED]

Owner Attestation and Signature Page\* 



Zoning Attestation.pdf

For fillable pdf of the Owner Attestation and Signature Page please visit the Applications and Forms section of our website: <https://www.providenceri.gov/inspection/boards-of-review/>

---

## Type of Application

Application Type\*

Dimensional Variance

List all Zoning Ordinance Sections from which a variance is sought. Include Section Number, Section Title, and Quantity of relief, if applicable (eg. 4' setback where 6' required)\*

Section 1301.E.3. - Field lighting heights

**Summarize any changes proposed for the Property (use, construction/renovation, site alteration):\***

The Applicant requests approval for 80-foot athletic field lighting poles for the existing baseball field at La Salle Academy. The increased height is necessary to achieve a better-controlled lighting design. The proposed system has been designed so that there is effectively zero vertical light spill at the property boundary. Lower 60-foot poles would require the fixtures to be aimed farther outward and at flatter angles to achieve the required field illumination, which would increase the potential for off-site spill light and glare. Therefore, the requested 80-foot height is not an intensification of impact; it is the mitigation measure that allows the lighting to be aimed more precisely onto the field of play while reducing impacts to adjacent properties. The lighting will be limited to athletic use, operated during controlled hours, and supported by the submitted photometric plan.

### Subject Property Information

**Address of Subject Property\***

612 Academy Avenue

**Plat\***

83

**Lot(s)\*** 

280

**Existing Zoning Use of the Property\***

Educational Facility - Primary or Secondary

**Proposed Zoning Use of the Property\***

Educational Facility - Primary or Secondary

**Base Zoning District\***

PS Public Space District

**Base Zoning District 2 (if applicable)**

—

**Overlay Zoning District (if applicable)**

—

**Overlay Zoning District 2 (if applicable)**

**Overlay Zoning District 3 (if applicable)**

—

—

**Date Owner Purchased the Property\***

**Start Date of Lessee's Occupancy**

10/01/2018

—

**Are there outstanding violations concerning the Property under the City of Providence Zoning Ordinance?\***

**Are there outstanding violations concerning the Property under the RI State Building or Property Maintenance Code(s)?\***

No

No

## Appendix A: Application for Variance(s)

### 1. What is the specific hardship from which the applicant seeks relief?\*

The Applicant seeks relief from the 60-foot maximum luminaire height applicable to outdoor recreational facilities in order to install athletic field lighting poles with a maximum height of 80 feet for the existing baseball field. The hardship is that strict compliance with the 60-foot height limit would prevent the Applicant from achieving a safe, uniform, and properly controlled athletic lighting design while also minimizing off-site light spill and glare. The proposed 80-foot pole height allows the fixtures to be aimed more directly onto the field of play. A lower 60-foot pole design would require flatter aiming angles and/or more forward-aimed fixtures, which would increase the potential for off-site light spill, glare, and visual impact at surrounding property boundaries.

**2. Specify all unique characteristics of the land or structure that cause the hardship:\***

The hardship is caused by the unique characteristics of the existing school campus and baseball field. The Property contains an existing educational/institutional campus with an existing outdoor baseball facility. The geometry and size of the baseball field, the required athletic illumination levels for safe play, the limited practical locations for poles around the field perimeter, and the need to control light at the property boundaries create a site-specific lighting challenge. The proposed pole height is directly related to those field-specific conditions. Because baseball fields require lighting over a large playing area and must maintain safe and uniform illumination for players while protecting adjacent properties from glare and light trespass, the 80-foot height is necessary to properly aim and control the fixtures.

**3 (a) Is the hardship caused by an economic disability?\***

No

**3 (b) Is the hardship caused by a physical disability?\***

No

**3 (c) If the response to subsection (b) is "yes," is the physical disability covered by the Americans with Disabilities Act of 1990 (ADA), 42 U.S.C. § 12101 et seq.? \***

No

**4. Did the owner/applicant take any prior action with respect to the Property that resulted in the need for the variance requested? (Examples include, but are not limited to, any changes the owner/applicant made to the structure(s), lot lines, or land, or changes in use of the Property)?\***

No

**5. If you are seeking a USE VARIANCE, set forth all facts that demonstrate that the Property cannot have any beneficial use if you are required to use it in a manner allowed in the zoning district:\***

Not applicable. The Applicant is not seeking a use variance. The proposed work relates to an existing school and outdoor recreational use. The request is for dimensional/special-use-related relief associated with the height of athletic field lighting poles, not for a new or prohibited use of the Property.

**6. If you are seeking a DIMENSIONAL VARIANCE, set forth all facts that indicate that if the variance is not granted, the hardship the owner/applicant will suffer is more than a mere inconvenience:\***

If the requested dimensional relief is not granted, the Applicant will be required to design the baseball field lighting around a 60-foot maximum pole height. That would create more than a mere inconvenience because it would materially affect the ability to provide safe, uniform, and properly controlled illumination for the existing baseball field. A 60-foot design would require the fixtures to be aimed farther outward and at flatter angles to reach the required areas of the field, increasing the potential for off-site light spill, glare, and visual impact. The proposed 80-foot height is the minimum practical relief necessary to allow the fixtures to be aimed more directly onto the field of play and to reduce impacts at the property boundaries. The relief is not requested for financial gain or to intensify the use of the Property; it is requested to achieve a safer and less impactful lighting design for the existing athletic facility.

**CITY OF PROVIDENCE ZONING BOARD OF REVIEW**

**DEPARTMENT OF INSPECTION + STANDARDS**

**444 Westminster Street, 1<sup>st</sup> Floor, Providence, Rhode Island 02903**

**ATTESTATION/OWNER AUTHORIZATION FOR  
APPLICATION FOR VARIANCE AND/OR SPECIAL USE PERMIT**

**ATTESTATION**

*The undersigned acknowledge(s) that the statements in the application herein and in any attachments or appendices are true and accurate, and that providing a false statement in this application may be subject to criminal and/or civil penalties as provided by law, including prosecution under the State and Municipal False Claims Acts. Owner(s)/Applicant(s) are jointly responsible with their attorney(s), if any, for any false statements. As indicated in the application instructions, neither the application nor this attestation may be signed by an attorney on behalf of their client(s).*

*The undersigned further acknowledge(s) and agree(s) that members of the Zoning Board of Review and its staff may enter upon the exterior of the Property in order to view the Property prior to any hearing on the application.*

Address, Plat, and Lot of Subject Property: 612 Academy Avenue Plat 83 Lot 276

**Owner(s)**

Name:

St. John Baptist De La Salle Institute

Signature:



Date:

06/09/2026

**Applicant(s)**

Name:

Patrick G. Meehan

Signature:

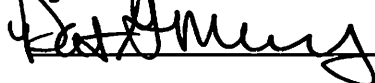

Date:

06/09/2026

**OWNER AUTHORIZATION**

To be completed if the online application is being filled out and submitted by someone other than the Owner of the subject property.

This is to certify that I St. John Baptist De La Salle Institute,

authorize Patrick G. Meehan (CFO) to submit this Zoning Board

of Review Application on my behalf for the property located at 612 Academy Avenue.

By signing this letter, I understand that I, or my attorney, must be present at the Zoning Board Meeting at which my application is scheduled to be heard.

Property Owner Name:

St. John Baptist De La Salle Institute

Date: 06/09/2026

Property Owner Signature:

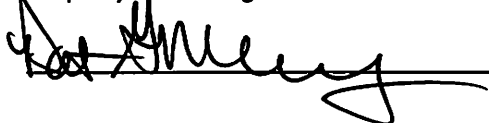

MUSCO LIGHTS

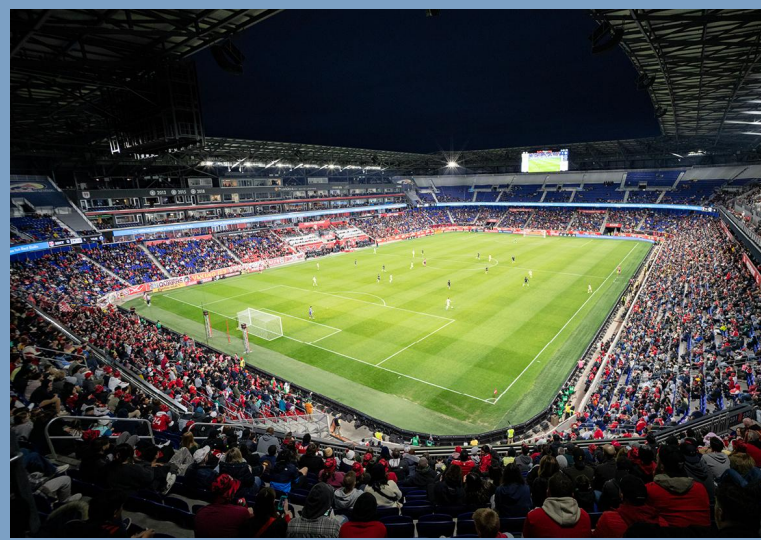

Sports Illustrated Stadium, Harrison, New Jersey, USA



UBS Arena, Elmont, New York, USA

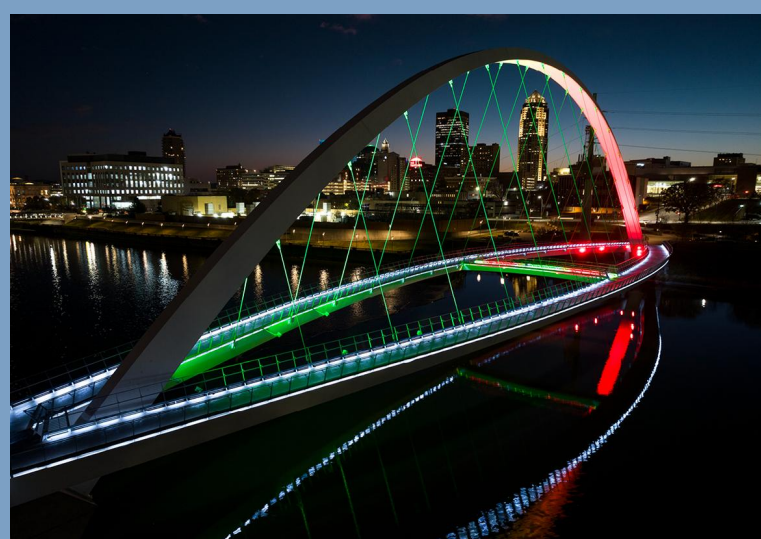

Iowa Women of Achievement Bridge, Des Moines, Iowa, USA



Tottenham Hotspur FC Training Ground, Tottenham, London, UK

## La Salle Academy Baseball

Providence, RI



Sales Representative: A.Grady · Designed By: T.Lanphier · Design No.: 251774A (ALL) · June 09, 2026

# La Salle Academy Baseball

Providence, RI

## LIGHTING SYSTEM

Structure/Fixture Summary							
Structure ID	Structure Height	Fixt. Attachment Ht.	Fixture Qty	Fixture Type	Design Load	Circuit	
A1-A2	80'	80'	1	TLC-LED-1200	1.16 kW	A	
		80'	4	TLC-LED-900	3.52 kW	A	
		16'	1	TLC-BT-575	0.57 kW	C	
B1	80'	80'	1	TLC-LED-1200	1.16 kW	B	
		80'	3	TLC-LED-1500	4.19 kW	B	
		80'	3	TLC-LED-900	2.64 kW	B	
		16'	2	TLC-BT-575	1.15 kW	C	
B2	80'	80'	1	TLC-LED-1200	1.16 kW	A	
		80'	3	TLC-LED-1500	4.19 kW	A	
		80'	3	TLC-LED-900	2.64 kW	A	
C1	70'	16'	2	TLC-BT-575	1.15 kW	C	
		70'	3	TLC-LED-1200	3.49 kW	A	
		70'	3	TLC-LED-900	2.64 kW	A	
C2	70'	16'	2	TLC-BT-575	1.15 kW	C	
		70'	2	TLC-LED-1200	2.33 kW	A	
		70'	4	TLC-LED-900	3.52 kW	A	
D1	70'	16'	2	TLC-BT-575	1.15 kW	C	
		70'	2	TLC-LED-900	1.76 kW	A	
		70'	4	TLC-LED-1200	4.66 kW	A	
D2	70'	16'	2	TLC-BT-575	1.15 kW	C	
		70'	2	TLC-LED-900	1.76 kW	B	
		70'	4	TLC-LED-1200	4.66 kW	B	
8			62		58.24 kW		

\*Fixtures in this design have dimmed output values to meet design specific needs.

Circuit Summary			
Circuit	Description	Design Load	Fixture Qty
A	Baseball / Soccer	35.77 kW	35
B	Baseball	14.42 kW	13
C	Balltrackers	8.05 kW	14

Fixture Type Summary								
Type	Circuit	Source	Avg. Wattage	Avg. Lumens	L90	L80	L70	Quantity
TLC-BT-575	C	LED 5700K - 75 CRI	575W	52,651	>120,000	>120,000	>120,000	14
TLC-LED-1200	A	LED 5700K - 75 CRI	1165W	149,739	>120,000	>120,000	>120,000	12
TLC-LED-1200	B	LED 5700K - 75 CRI	1165W	148,947	>120,000	>120,000	>120,000	5
TLC-LED-1500	A	LED 5700K - 75 CRI	1397W	180,616	>120,000	>120,000	>120,000	3
TLC-LED-1500	B	LED 5700K - 75 CRI	1397W	182,487	>120,000	>120,000	>120,000	3
TLC-LED-900	A	LED 5700K - 75 CRI	880W	104,455	>120,000	>120,000	>120,000	20
TLC-LED-900	B	LED 5700K - 75 CRI	880W	104,529	>120,000	>120,000	>120,000	5

Single Fixture Amperage Draw Chart								
Driver Specifications (.90 min power factor)	Line Amperage Per Fixture (max draw)							
	208 (60)	220 (60)	240 (60)	277 (60)	347 (60)	380 (60)	480 (60)	
Single Phase Voltage								
TLC-LED-1500	8.4	7.9	7.3	6.3	5.0	4.6	3.6	
TLC-LED-1200	6.9	6.5	6.0	5.2	4.2	3.8	3.0	
TLC-LED-900	5.2	4.9	4.5	3.9	3.1	2.9	2.3	
TLC-BT-575	3.3	3.2	2.9	2.5	2.0	1.8	1.5	

\*Amp draw based on 100% fixture output, consult design specific datasheet for adjusted amperage draw chart

## Light Level Summary

Calculation Grid Summary								
Grid Name	Calculation Metric	Illumination Ave					Circuits	Fixture Qty
		Ave	Min	Max	Max/Min	Ave/Min		
Baseball (Infield)	Horizontal Illuminance	53.58	46	62	1.37	1.18	A,B,C	62
Baseball (Outfield)	Horizontal Illuminance	50.56	32	61	1.89	1.57	A,B,C	62
Soccer	Horizontal Illuminance	32.77	20	47	2.39	1.67	A	35
Spill at 150' (3')	Horizontal Illuminance	0.0045	0.00	0.02	-	-	A,B	48
Spill at 150' (5')	Max Candela Metric	423.2767	5.88	979.43	166.644	72.018	A,B	48
Spill at 150' (5')	Max Vertical Illuminance Metric	0.0105	0.00	0.03	-	-	A,B	48

**NOTES: Horizontal Footcandle**  
A measure of light energy taken by holding a light meter in a horizontal position 36 inches above the playing surface. It is the standard method of measuring the quantity of light in sports lighting.

**Vertical Footcandle**  
Measurement of light in the non-horizontal plane. This could be at various vertical angles with the most common being 90 degrees.

**Guaranteed Performance:** The ILLUMINATION described above is guaranteed per your Musco Warranty document.

**Field Measurements:** Individual field measurements may vary from computer-calculated predictions.

**Electrical System Requirements:** Refer to Amperage Draw Chart and/or the "Musco Control System Summary" for electrical sizing.

**Installation Requirements:** Results assume ± 3% nominal voltage at line side of the driver and structures located within 3 feet (1m) of design locations.



Equipment List For Areas Shown								
Structure				Fixtures				
QTY	STRUCTURE ID	SIZE	GRADE ELEVATION	ABOVE FIELD LEVEL	FIXTURE TYPE	QTY/POLE	THIS GRID	OTHER GRIDS
2	A1-A2	80'	-	80'	TLC-LED-1200	1	1	0
				80'	TLC-LED-900	4	4	0
				15.5'	TLC-BT-575	1	1	0
2	B1-B2	80'	-	80'	TLC-LED-1200	1	1	0
				80'	TLC-LED-1500	3	3	0
				15.5'	TLC-LED-900	3	3	0
1	C1	70'	-	70'	TLC-LED-1200	3	3	0
				70'	TLC-LED-900	3	3	0
				15.5'	TLC-BT-575	2	2	0
1	C2	70'	-	70'	TLC-LED-1200	2	2	0
				70'	TLC-LED-900	4	4	0
				15.5'	TLC-BT-575	2	2	0
2	D1-D2	70'	-	70'	TLC-LED-1200	4	4	0
				70'	TLC-LED-900	2	2	0
				15.5'	TLC-BT-575	2	2	0
8	Totals					62	62	0

Above Field Level is height of fixtures above area shown

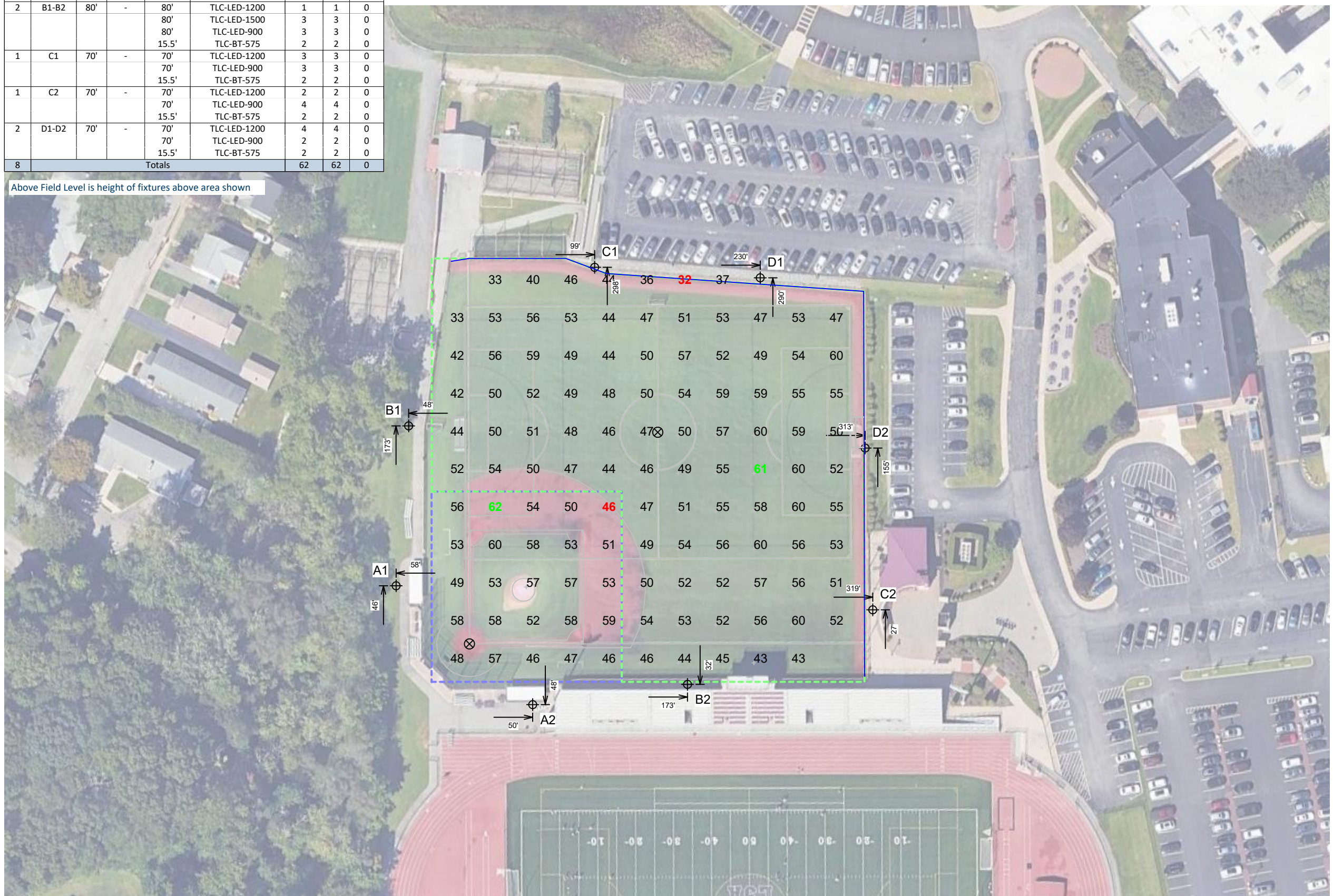

# La Salle Academy Baseball

Providence, RI

Grid Summary	
Name:	Baseball
Size:	Irregular 305'/398'/312'
Spacing:	30.0' x 30.0'
Height:	3.0' above grade

	MAINTAINED HORIZONTAL FOOTCANDLES	
	Infield	Outfield
<b>Guaranteed Average:</b>	<b>50</b>	<b>50</b>
Scan Average:	53.58	50.56
Maximum:	62	61
Minimum:	46	32
Avg/Min:	1.18	1.57
<b>Guaranteed Max/Min:</b>	<b>2</b>	<b>2</b>
Max/Min:	1.37	1.89
UG (adjacent pts):	1.27	1.62
CU:	0.79	
No. of Points:	25	91
<b>FIXTURE INFORMATION</b>		
Applied Circuits:	A,B,C	
<b>No. of Fixtures:</b>	<b>62</b>	
Total Load:	58.24 kW	

**Guaranteed Performance:** The ILLUMINATION described above is guaranteed per your Musco Warranty document.

**Field Measurements:** Individual field measurements may vary from computer-calculated predictions.

**Electrical System Requirements:** Refer to Amperage Draw Chart and/or the "Musco Control System Summary" for electrical sizing.

**Installation Requirements:** Results assume ± 3% nominal voltage at line side of the driver and structures located within 3 feet (1m) of design locations.

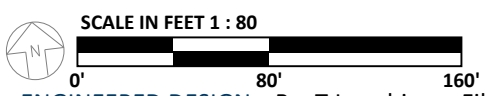

Pole location(s) ⊕ dimensions are relative to 0,0 reference point(s) ⊗



Equipment List For Areas Shown								
Structure				Fixtures				
QTY	STRUCTURE ID	SIZE	GRADE ELEVATION	ABOVE FIELD LEVEL	FIXTURE TYPE	QTY/POLE	THIS GRID	OTHER GRIDS
2	A1-A2	80'	-	80'	TLC-LED-1200	1	1	0
				80'	TLC-LED-900	4	4	0
				15.5'	TLC-BT-575	1	0	1
1	B2	80'	-	80'	TLC-LED-1200	1	1	0
				80'	TLC-LED-1500	3	3	0
				80'	TLC-LED-900	3	3	0
				15.5'	TLC-BT-575	2	0	2
1	C1	70'	-	70'	TLC-LED-1200	3	3	0
				70'	TLC-LED-900	3	3	0
				15.5'	TLC-BT-575	2	0	2
1	C2	70'	-	70'	TLC-LED-1200	2	2	0
				70'	TLC-LED-900	4	4	0
				15.5'	TLC-BT-575	2	0	2
1	D1	70'	-	70'	TLC-LED-1200	4	4	0
				70'	TLC-LED-900	2	2	0
				15.5'	TLC-BT-575	2	0	2
6	Totals					45	35	10

Above Field Level is height of fixtures above area shown

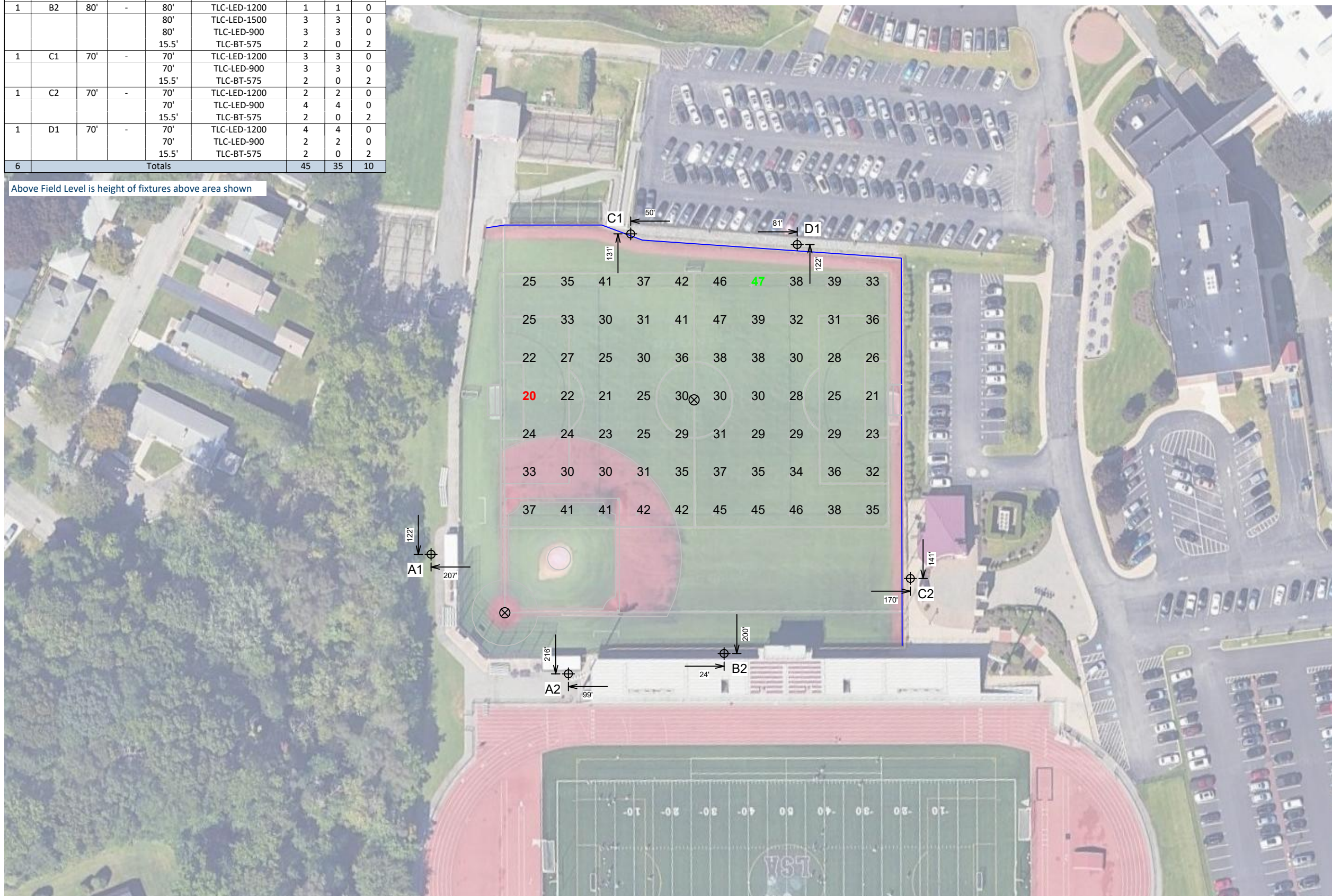

### La Salle Academy Baseball

Providence, RI

#### Grid Summary

**Name:** Soccer  
**Size:** 305' x 200'  
**Spacing:** 30.0' x 30.0'  
**Height:** 3.0' above grade

#### ILLUMINATION SUMMARY

MAINTAINED HORIZONTAL FOOTCANDLES

	Entire Grid
<b>Guaranteed Average:</b>	<b>30</b>
Scan Average:	32.77
Maximum:	47
Minimum:	20
Avg/Min:	1.67
<b>Guaranteed Max/Min:</b>	<b>2.5</b>
Max/Min:	2.39
UG (adjacent pts):	1.38
CU:	0.47
No. of Points:	70
<b>FIXTURE INFORMATION</b>	
Applied Circuits:	A
<b>No. of Fixtures:</b>	<b>35</b>
Total Load:	35.77 kW

**Guaranteed Performance:** The ILLUMINATION described above is guaranteed per your Musco Warranty document.

**Field Measurements:** Individual field measurements may vary from computer-calculated predictions.

**Electrical System Requirements:** Refer to Amperage Draw Chart and/or the "Musco Control System Summary" for electrical sizing.

**Installation Requirements:** Results assume ± 3% nominal voltage at line side of the driver and structures located within 3 feet (1m) of design locations.

SCALE IN FEET 1 : 80

ENGINEERED DESIGN By: T.Lanphier • File #251774A (ALL) • 09-Jun-26

Pole location(s) ⊕ dimensions are relative to 0,0 reference point(s) ⊗



Not to be reproduced in whole or part without the written consent of Musco Sports Lighting, LLC. ©1981, 2026 Musco Sports Lighting, LLC.

# La Salle Academy Baseball

Providence, RI

Grid Summary	
Name:	Spill at 150' (3')
Spacing:	30.0'
Height:	3.0' above grade

Illumination Summary	
	INITIAL HORIZONTAL FOOTCANDLES
Scan Average:	0.0045
Maximum:	0.02
Minimum:	0.00
CU:	0.00
No. of Points:	72
<b>FIXTURE INFORMATION</b>	
Applied Circuits:	A,B
No. of Fixtures:	48
Total Load:	50.19 kW

**Guaranteed Performance:** The ILLUMINATION described above is guaranteed per your Musco Warranty document.

**Field Measurements:** Individual field measurements may vary from computer-calculated predictions.

**Electrical System Requirements:** Refer to Amperage Draw Chart and/or the "Musco Control System Summary" for electrical sizing.

**Installation Requirements:** Results assume ± 3% nominal voltage at line side of the driver and structures located within 3 feet (1m) of design locations.



SCALE IN FEET 1 : 100  
 0' 100' 200'  
 ENGINEERED DESIGN By: T.Lanphier • File #251774A (ALL) • 09-Jun-26

Pole location(s) ⊕ dimensions are relative to 0,0 reference point(s) ⊗



Not to be reproduced in whole or part without the written consent of Musco Sports Lighting, LLC. ©1981, 2026 Musco Sports Lighting, LLC.

## ILLUMINATION SUMMARY

# La Salle Academy Baseball

Providence, RI

Grid Summary	
Name:	Spill at 150' (5')
Spacing:	30.0'
Height:	5.0' above grade

Illumination Summary	
INITIAL MAX VERTICAL FOOTCANDLES	
Scan Average:	0.0105
Maximum:	0.03
Minimum:	0.00
CU:	0.00
No. of Points:	72
FIXTURE INFORMATION	
Applied Circuits:	A,B
No. of Fixtures:	48
Total Load:	50.19 kW

**Guaranteed Performance:** The ILLUMINATION described above is guaranteed per your Musco Warranty document.

**Field Measurements:** Individual field measurements may vary from computer-calculated predictions.

**Electrical System Requirements:** Refer to Amperage Draw Chart and/or the "Musco Control System Summary" for electrical sizing.

**Installation Requirements:** Results assume ± 3% nominal voltage at line side of the driver and structures located within 3 feet (1m) of design locations.



SCALE IN FEET 1 : 100  
 0' 100' 200'  
 ENGINEERED DESIGN By: T.Lanphier • File #251774A (ALL) • 09-Jun-26

Pole location(s) ⊕ dimensions are relative to 0,0 reference point(s) ⊗



Not to be reproduced in whole or part without the written consent of Musco Sports Lighting, LLC. ©1981, 2026 Musco Sports Lighting, LLC.

## ILLUMINATION SUMMARY

# La Salle Academy Baseball

Providence, RI

## Equipment Layout

**INCLUDES:**  
 - Baseball  
 - Soccer

**Electrical System Requirements:** Refer to Amperage Draw Chart and/or the "Musco Control System Summary" for electrical sizing.

**Installation Requirements:** Results assume ± 3% nominal voltage at line side of the driver and structures located within 3 feet (1m) of design locations.

## Equipment List For Areas Shown

QTY	Structure			Fixtures		
	STRUCTURE ID	SIZE	GLOBAL ELEVATION	ABOVE GLOBAL LEVEL	FIXTURE TYPE	QTY/POLE
2	A1-A2	80'	-	80'	TLC-LED-1200	1
				80'	TLC-LED-900	4
				15.5'	TLC-BT-575	1
2	B1-B2	80'	-	80'	TLC-LED-1200	1
				80'	TLC-LED-1500	3
				15.5'	TLC-LED-900	3
1	C1	70'	-	70'	TLC-LED-1200	3
				70'	TLC-LED-900	3
				15.5'	TLC-BT-575	2
1	C2	70'	-	70'	TLC-LED-1200	2
				70'	TLC-LED-900	4
				15.5'	TLC-BT-575	2
2	D1-D2	70'	-	70'	TLC-LED-1200	4
				70'	TLC-LED-900	2
				15.5'	TLC-BT-575	2
8	Totals					62

Above Global Level is height of fixtures above design (0,0,0)

## Single Fixture Amperage Draw Chart

Driver Specifications (.90 min power factor)	Line Amperage Per Fixture (max draw)						
	208 (60)	220 (60)	240 (60)	277 (60)	347 (60)	380 (60)	480 (60)
Single Phase Voltage							
TLC-LED-1500	8.4	7.9	7.3	6.3	5.0	4.6	3.6
TLC-LED-1200	6.9	6.5	6.0	5.2	4.2	3.8	3.0
TLC-LED-900	5.2	4.9	4.5	3.9	3.1	2.9	2.3
TLC-BT-575	3.3	3.2	2.9	2.5	2.0	1.8	1.5

\*Amp draw based on 100% fixture output, consult design specific datasheet for adjusted amperage draw chart



Pole location(s) ⊕ dimensions are relative to 0,0 reference point(s) ⊗

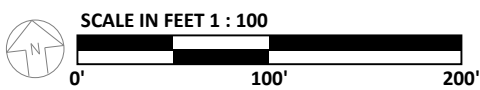

## PLANS FOR REFERENCE



# LA SALLE ACADEMY

## JOHN P. CRONIN FIELD RENOVATION PROJECT

### PROVIDENCE, RHODE ISLAND

**DRAWING INDEX:**

SHEET	DESCRIPTION
CIVIL PLANS	
C-1	COVER SHEET
C-2	GENERAL NOTES
C-3	EXISTING CONDITIONS PLAN
C-4	DEMOLITION & EROSION CONTROL PLAN (TBP_
C-5	LAYOUT AND MATERIALS PLAN
C-6	GRADING PLAN
C-7	DRAINAGE AND UTILITY PLAN
C-8	GRAND STAND LAYOUT PLAN
C-9	PRESS BOX PLAN
C-10	CONSTRUCTION DETAILS
C-11	CONSTRUCTION DETAILS
C-12	CONSTRUCTION DETAILS
C-13	CONSTRUCTION DETAILS

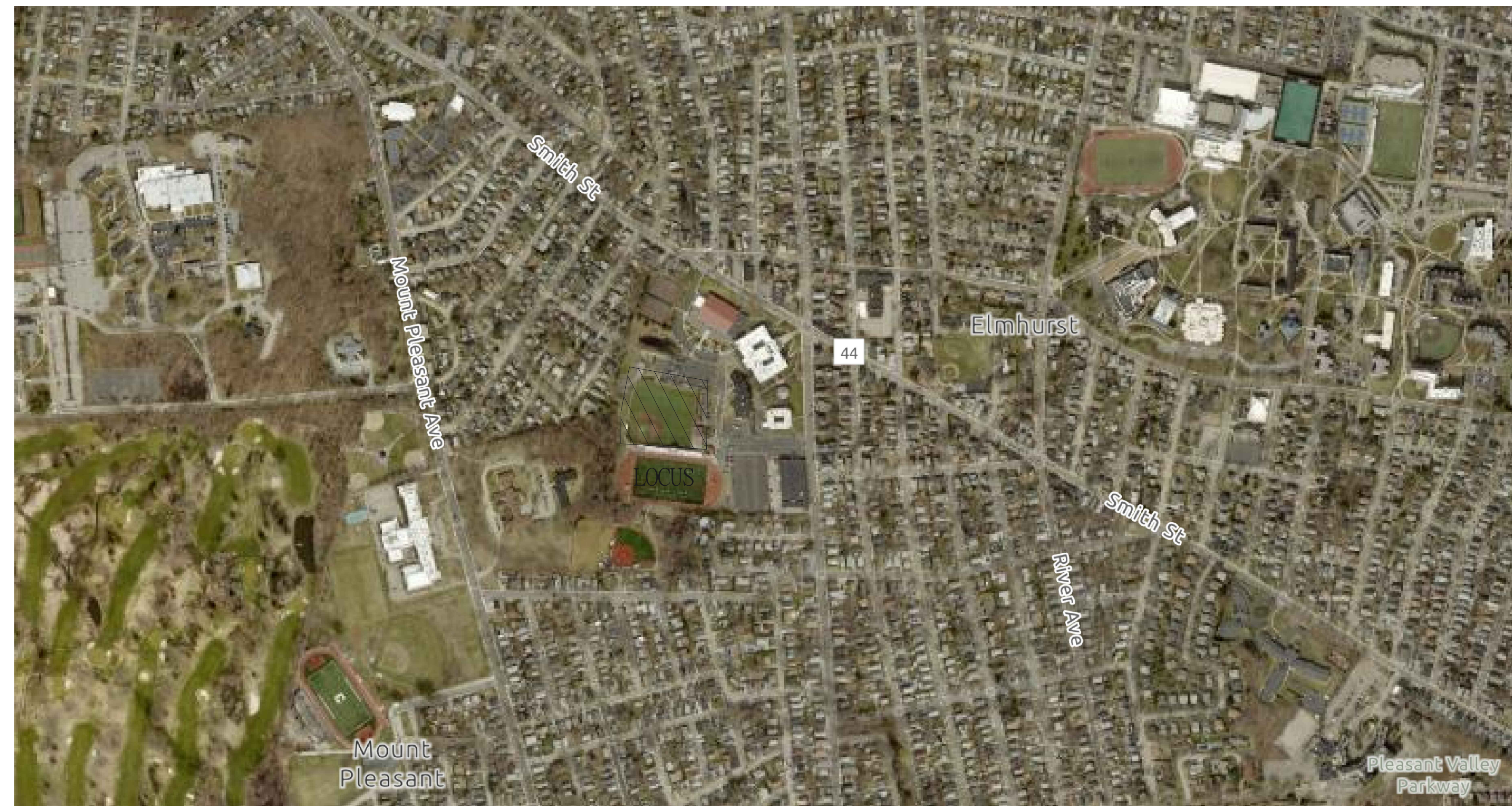

**CIVIL ENGINEER:**  
 NESRA ENGINEERING, LLC  
 111 WASHINGTON STREET  
 PLAINVILLE, MA 02762  
 P: (617) 506-3772

**ELECTRICAL ENGINEER:**  
 VINCENT A. DILORIO, INC.  
 89 ACCESS ROAD #18,  
 NORWOOD, MA 02062  
 P: (781) 255-9754

**WETLAND CONSULTANT:**  
 GM2  
 200 MAIN STREET  
 SUITE 300  
 PAWTUCKET, RI 02860  
 P: (401) 726-4084

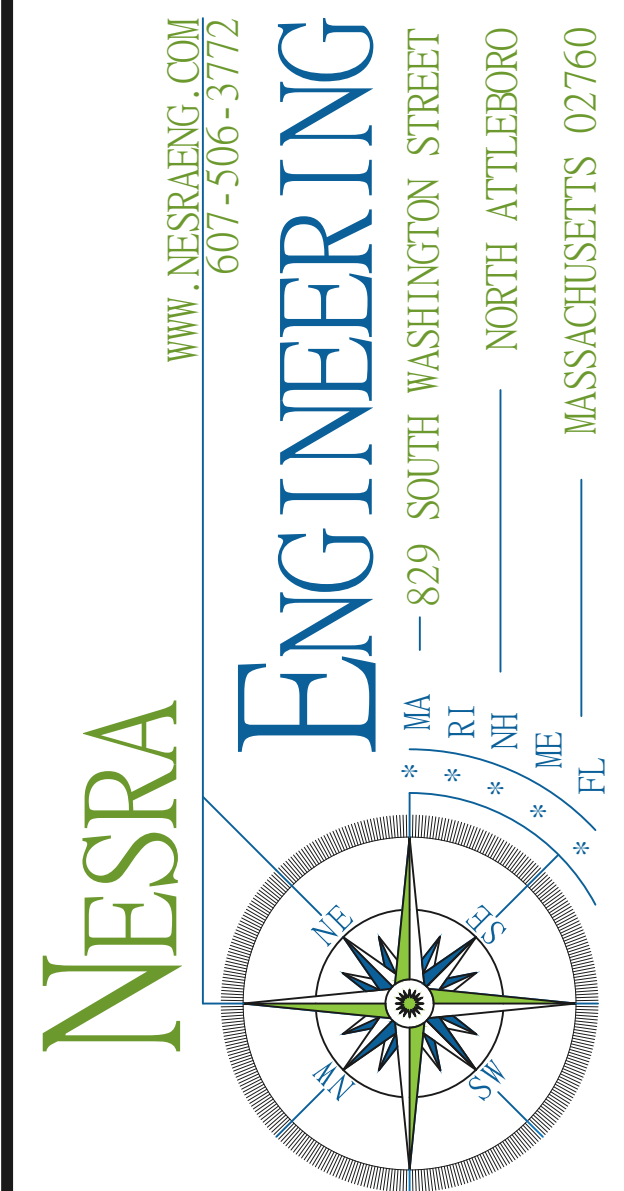

**PROJECT**  
 LA SALLE ACADEMY JOHN P. CRONIN FIELD RENOVATION PROJECT, 612 ACADEMY AVE, PROVIDENCE, RI 02908

**CLIENT**  
 LA SALLE ACADEMY  
 612 ACADEMY AVE  
 PROVIDENCE, RI 02908

**BID SET**

NO.	REVISION	DATE

SCALE - AS NOTED  
 DATE - 9/15/25

PROFESSIONAL SEAL

COVER SHEET

# C-1

**EROSION CONTROL NOTES:**

1. AN AREA SHALL BE CONSIDERED STABLE IF ONE OF THE FOLLOWING HAS OCCURRED:
  - A. GRAVEL BASE COURSE HAS BEEN INSTALLED IN AREAS TO BE PAVED;
  - B. A MINIMUM OF 8% VEGETATED GROWTH HAS BEEN ESTABLISHED;
  - C. A MINIMUM OF 3" OF NON-EROSIVE MATERIAL SUCH AS STONE FOR RIP RAP HAS BEEN INSTALLED;
  - D. EROSION CONTROL BLANKETS HAVE BEEN PROPERLY INSTALLED;
2. THE CONTRACTOR SHALL CONDUCT DAILY AND TIMELY INSPECTION OF BOTH TEMPORARY AND PERMANENT EROSION AND SEDIMENT CONTROL MEASURES.
3. CONSTRUCTION SHALL PROCEED IN SUCH A MANNER AS TO FACILITATE INSTALLATION OF EROSION CONTROL MEASURES AND THE COMPLETION OF GRADING, SEEDING, AND LANDSCAPING AS SOON AS POSSIBLE WITHIN AN AREA. THIS PROCEDURE SHOULD RESULT IN THE EXPOSURE OF THE SMALLEST PRACTICAL LAND AREA AT ANY ONE TIME.
4. INSTALL SILT SOCKS AS SHOWN ON PLAN AND IN DETAIL BEFORE EARTHWORK COMMENCES. ADDITIONAL SILT SOCKS MAY BE REQUIRED AS WORK CONTINUES. CONTRACTOR SHALL PROVIDE UP TO 500 FEET OF ADDITIONAL SILT SOCKS AS NEEDED AT NO ADDITIONAL COST.
5. CUT AND FILL SLOPES BOTH CALL FOR EROSION CONTROL MEASURES.
6. ALL DISTURBED AREAS SHALL HAVE TOPSOIL SPREAD (8" MINIMUM) AND BE LIMED, FERTILIZED, TILLED, SEEDED AND MULCHED. ALL SLOPES 3:1 (3 RUN 1 RISE) AND STEEPER SHALL HAVE MULCH HELD IN PLACE WITH BIODEGRADABLE JUTE NETTING, STAPLED AND STAKED. EACH AREA SHALL BE LIMED, FERTILIZED, PREPARED, SEEDED AND MULCHED (WITH ANCHORED NETTING IF REQUIRED) WITHIN 24 HOURS OF FINAL GRADING. WHEN PERMANENT SEEDING CANNOT BE INSTALLED BY SEPTEMBER 15, TEMPORARY SEEDING AND MULCHING OF ALL DISTURBED AREAS SHALL BE INSTALLED IMMEDIATELY AND MAINTAINED IN THAT CONDITION UNTIL PERMANENT PRACTICES CAN BE INSTALLED IN THE FOLLOWING PLANTING SEASON.
7. TEMPORARY STABILIZATION OF DISTURBED AREAS: SEED BED PREPARATION: TILL THREE INCHES DEEP MIXING IN FERTILIZER. APPLY LIME 2 TONS/ACRE (100#/1,000 SQ. FT.) FERTILIZE: UNIFORMLY APPLY NOT LESS THAN 300#/ACRE (7#/1,000 SQ. FT.) OF 10-20-20 OR EQUIVALENT. SEEDING: SELECT APPROPRIATE SEEDING MIXTURE FROM TABLE 1 BELOW. SPREAD SEED UNIFORMLY. FIRM SOIL BY ROLLING OR PACKING; IF NOT FEASIBLE, THAN RAKE LIGHTLY TO COVER SEEDS. MULCHING: MULCH ALL DISTURBED AREAS WITH 1- 1/2 TO 2 TONS OF STRAW OR SALT MARSH HAY PER ACRE (70-90# / 1,000 SQ. FT.) ANCHOR ON ALL SLOPES 3:1 OR STEEPER AND FLATTER SLOPES SUBJECT TO WASHOUTS OR WIND BLOWING. JUTE OR OTHER BIODEGRADABLE NETTING, STAKING AND STAPLING MAY BE REQUIRED.

**TABLE 1  
PLANT SELECTION AND SEEDING RATES**

SPECIES	PER ACRE	PER 1,000 SQ. FT.	REMARKS
WINTER RYE	2 BU OR 112 LBS.	2.6 LBS.	BEST FOR FALL SEEDING. SEED AUGUST 15 TO SEPTEMBER 15 FOR BEST COVER. SEED TO DEPTH OF ONE INCH.
OATS	2 1/2 BU OR 90 LBS.	2 LBS.	BEST FOR SPRING SEEDINGS. LATER THAN MAY 15 FOR SUMMER PROTECTION. SEED TO DEPTH OF ONE INCH.
ANNUAL RYE 40 LBS.	1. LB		GROWS QUICKLY, BUT IS FOR SHORT GRASS DURATION. USE WHERE APPEARANCES ARE IMPORTANT, COVER SEED WITH NO MORE THAN 1/2 INCH OF SOIL WITH MULCH. SEEDING MAY BE DONE THROUGHOUT GROWING SEASON. OTHERWISE SEED EARLY SPRING OR BETWEEN AUGUST 15 AND SEPTEMBER 15.

8. PERMANENT STABILIZATION OF DISTURBED AREAS: SEED BED PREPARATION: TOPSOIL (SANDY LOAM, LOAM, OR SILT LOAM), FRIABLE, FREE OF TREE ROOTS, WEEDS, STONES MORE THAN 1- 1/2 INCHES IN DIAMETER OR LENGTH SHALL BE PLACED OVER ALL DISTURBED AREAS IN A 6" MINIMUM AND 8" MAXIMUM THICK LAYER. TOPSOIL SHALL BE FREE OF HERBICIDES AND TOXIC MATERIALS. TILL 4 INCHES DEEP MIXING IN THE FERTILIZER AND LIME. APPLY LIME 2 TONS/ACRE (100# / 1,000 SQ. FT.) FERTILIZER: UNIFORMLY APPLY NOT LESS THAN 500#/ACRE (12#/1,000 SQ. FT.) OF 10-20-20 OR EQUIVALENT. SEEDING: SPREAD SEED UNIFORMLY. FIRM SOIL BY ROLLING OR PACKING; IF NOT FEASIBLE, THAN RAKE LIGHTLY TO COVER SEEDS. MULCHING: MULCH ALL DISTURBED AREAS WITH 1- 1/2 TO 2 TONS OF HAY OR STRAW PER ACRE (70-90# / 1,000 SQ. FT.). ANCHOR ON ALL SLOPES 3:1 OR STEEPER AND ON LATTER SLOPES SUBJECT TO WASH (WATERWAYS) AND/OR WINDBLOWN USING JUTE OR OTHER BIODEGRADABLE NETTING, STAKING, AND STAPLING.
9. TEMPORARY EROSION CONTROL MEASURES SHALL NOT BE REMOVED UNTIL ALL DISTURBED AREAS HAVE BEEN STABILIZED.
10. MAINTENANCE: DURING THE CONSTRUCTION PERIOD AND UNTIL SUCH TIME AS THE LONG TERM VEGETATION IS ESTABLISHED.
  - A. DISTURBED AREAS WILL BE FERTILIZED AND RESEEDED.
  - B. CATCH BASINS WILL BE CHECKED AND CLEANED AS NECESSARY.
  - C. DRAINAGE AND GRASS TREATMENT SWALES SHALL BE CHECKED FREQUENTLY AND CLEANED AS REQUIRED.
  - D. THE HAYBALE DIRKS WILL BE CHECKED ON A REGULAR BASIS AND REPAIRED AS NECESSARY TO CORRECT ANY DAMAGE, DETERIORATION, AND SHORT CIRCUITING.
11. SITE VISITS: THE ENGINEER SHALL BE CONTACTED ON A REGULAR BASIS TO OBSERVE ALL EROSION CONTROL PRACTICES AS WELL AS THE MAINTENANCE OF THE EROSION CONTROL COMPONENTS. REFER TO CONSTRUCTION SPECIFICATIONS FOR ADDITIONAL REQUIREMENTS. EROSION CONTROL PRACTICES SHALL BE IN STRICT ACCORDANCE WITH THE APPROVED PLANS AND SPECIFICATIONS.
12. ALL TREATMENT SWALES AND DITCHES SHALL BE ESTABLISHED PRIOR TO DIRECTING RUNOFF TO THEM.

**CONSTRUCTION SEQUENCE:**

1. GENERAL CONTRACTOR IS RESPONSIBLE FOR OBTAINING RIPDES GENERAL CONSTRUCTION PERMIT AND PREPARE THE ASSOCIATED STORMWATER POLLUTION PREVENTION PLAN (SWPPP).
2. INSTALL SILT SOCKS AT ALL LOCATIONS INDICATED ON PLAN AND AT OTHER LOCATIONS AS DETERMINED BY ENGINEER. INSTALL OTHER TEMPORARY AND PERMANENT EROSION AND SEDIMENT CONTROL MEASURES AS EARTHWORK PROCEEDS AND AS DETERMINED NECESSARY BY THE ENGINEER.
3. CONSTRUCT INLET PROTECTION AT ALL CATCH BASINS.
4. STABILIZE CONSTRUCTION ENTRANCES AND TEMPORARY ACCESS ROADS WITH COARSE AGGREGATE 4 INCHES (MINIMUM) OVER COMPACTED FILL AREAS TO PREVENT OFF-SITE TRACKING BY VEHICLES AND EQUIPMENT.
5. INSPECT ALL DISTURBED AREAS ON A DAILY BASIS. FOLLOWING THE DAILY INSPECTION, INSTALL AS REQUIRED ANY AND ALL TEMPORARY DRAINAGE, EROSION, AND SEDIMENT CONTROL PRACTICES AS INDICATED, I.E., DIVERSION CHANNELS, BERMS, DRAINS, DITCHES, SEED AND MULCH OR OTHER PRACTICES.
6. REMOVE AND DISPOSE SYNTHETIC TURF FIELD, ALONG WITH CRUMB RUBBER AND SAND INFILL.
7. REMOVE AND DISPOSE TOP STONE AND BASE STONE MATERIAL.
8. REMOVE AND DISPOSE FLAT PANEL DRAINS, AND FILTER FABRIC.
9. EXCAVATE AND REMOVE COLLECTOR PIPE.
10. RE-GRADE SUB BASE AND INSTALL NEW FILTER FABRIC.
11. EXCAVATE AND INSTALL NEW COLLECTOR PIPES.
12. INSTALL NEW FLAT PANEL DRAINS AND CONNECT TO COLLECTOR PIPES.
13. CONNECT COLLECTOR PIPE TO OUTLET STRUCTURE.
14. INSTALL CRUSHED STONE BASE MATERIAL AND TOP STONE.
15. PERFORM SURVEY GRID AND SUBMIT TO ENGINEER FOR REVIEW AND APPROVAL.
16. CONDUCT INFILTRATION TESTING AND PLANARITY TESTING.
17. INSTALL NEW EMERGENCY ACCESS AND UPGRADE EXISTING TREATMENT AREA ADJACENT TO THE PARKING LOT. REPLACE DAMAGED PIPING.
18. AFTER APPROVAL INSTALL NEW SYNTHETIC TURF FIELD AND INFILL. (INCLUDING ALL WARNING TRACKS, STRIPING, INFIELD, LOGOS, ETC.)
19. IF BLEACHERS, PRESS BOX AND BACKSTOP ALTERNATES ARE SELECTED, REMOVE AND DISPOSE DUGOUTS, BACKSTOP, PAVEMENT AND PADS AS INDICATED ON THE DEMOLITION PLANS.
20. INSTALL NEW TENSION NETTING POLES AND NETTING SYSTEM.
21. POUR NEW CONCRETE PADS FOR DUGOUTS, AND INSTALL PREFABRICATED DUGOUTS.
22. POUR NEW CONCRETE PADS FOR BLEACHERS AND PRESS BOX.
23. INSTALL PREFABRICATED PRESS BOX AND MANUFACTURED GRANDSTANDS, INCLUDING RAMPS, STEPS, ANCHORING, ETC.
24. IF LIGHTING ALTERNATE IS SELECTED, INSTALL NEW CONDUITS, HAND HOLES AND LIGHT POLE FOUNDATIONS.
25. INSTALL LIGHT POLES AND FIXTURES.
26. INSTALL WIRING AND CONNECTIONS.
27. TEST LIGHTING SYSTEM AND CONTROLS.
28. PAVE NEW WALKWAYS.
29. PLACE TOPSOIL, COMPLETE PERMANENT FERTILIZING, LIMING, SEEDING AND MULCHING.
30. CLEAN AND RESTORE SILT DETENTION SITES AND DRAINAGE STRUCTURES. REMOVE OTHER EROSION CONTROL PRACTICES ON A TIMELY BASIS AS PERMANENT MEASURES TAKE HOLD. SPOT FERTILIZE, SEED, AND MULCH AS REQUIRED.
31. INSPECT AND MAINTAIN GRADING, EROSION CONTROL AND SEDIMENT CONTROL PRACTICES WEEKLY AND IMMEDIATELY AFTER ALL STORMS OF MORE THAN 1/2 INCH PRECIPITATION IN 24 HOURS.
32. REFER TO EROSION CONTROL NOTES FOR ADDITIONAL DETAILS RELATIVE TO THE REQUIRED CONSTRUCTION SEQUENCE.
33. MAINTENANCE OF ALL EROSION AND SEDIMENT CONTROL COMPONENTS AND INSTALLATION OF ADDITIONAL EROSION AND SEDIMENT CONTROL COMPONENTS SHALL BE AN ONGOING PRACTICE AND IN STRICT ACCORDANCE WITH THE CONTRACT SPECIFICATIONS.
34. PERFORM AS-BUILT SURVEY AND SUBMIT AS-BUILT AND RECORD DRAWINGS.
35. TRAIN OWNER'S REPRESENTATIVES IN MAINTENANCE AND OPERATIONS OF SCOREBOARDS, LIGHTING, TURF GROOMING, ETC.
36. COMPLETE PROJECT PUNCH LIST.
37. SUBMIT ALL REQUIRED DOCUMENTATION, INCLUDING BUT NOT LIMITED TO WARRANTIES, MAINTENANCE DOCUMENTS, RECORD DOCUMENTS, ETC.

**GENERAL NOTES:**

1. ALL SITE WORK SHALL BE CONSTRUCTED IN ACCORDANCE WITH THE LOCAL DPW SPECIFICATIONS.
2. THE CONTRACTOR IS RESPONSIBLE FOR OBTAINING AND PAYING FOR ALL NECESSARY CONSTRUCTION PERMITS REQUIRED TO COMPLETE THE WORK.
3. ALL UTILITY SIZES, LOCATIONS, AND APPURTENANCES ARE SUBJECT TO THE APPROVAL AND/ OR REVISION OF THE RESPECTIVE UTILITY HAVING JURISDICTION.
4. NOTIFY "DIG-SAFE" (1-888-344-7233) AND THE LOCAL DPW TO VERIFY THE LOCATION, DEPTH AND SIZE OF THE EXISTING UTILITY SERVICE CONNECTIONS PRIOR TO CONSTRUCTION.
5. THE CONTRACTOR IS RESPONSIBLE FOR LOAMING AND HYDROSEEDING AREAS DISTURBED BY CONSTRUCTION OPERATIONS.
6. ALL MATERIAL TO BE REMOVED MUST BE REMOVED FROM THE SITE AND DISPOSED OF LEGALLY.
7. ALL EXISTING UTILITIES SHALL BE PROTECTED UNLESS OTHERWISE SPECIFIED.
8. ALL EROSION CONTROL TO BE INSTALLED PRIOR TO ANY OTHER WORK ON THE SITE.
9. WALKWAY CROSS SLOPES, AS INDICATED IN THE STANDARD SPECIFICATIONS, WILL BE AT 1.6% MAXIMUM, 1.5% PREFERRED, IN ACCORDANCE WITH THE ARCHITECTURAL ACCESS BOARD (AAB) RULES AND REGULATIONS, THE SIDEWALK CROSS SLOPE CANNOT EXCEED 2.0%.
10. ANY ALTERATIONS REQUIRED ON THESE DRAWINGS DURING CONSTRUCTION SHALL BE APPROVED BY THE PROJECT ENGINEER AND THE CITY PRIOR TO CONSTRUCTION AND SHALL BE RECORDED ON THE "AS-BUILT" DRAWINGS.
11. THE CONTRACTOR SHALL COORDINATE ALL WORK AND TIME SCHEDULES WITH THE TOWN AND THEIR REPRESENTATIVES.

**DIMENSIONS AND QUANTITIES:**

1. ALL DIMENSIONS AND QUANTITIES SHALL BE DETERMINED OR VERIFIED BY THE CONTRACTOR PRIOR TO THE START OF CONSTRUCTION.
2. THE INFORMATION ON THE CONTRACT DRAWINGS HAS BEEN COMPILED FROM VARIOUS SOURCES AND MAY NOT REFLECT THE ACTUAL CONDITIONS AT THE TIME OF CONSTRUCTION.
3. THE CONTRACTOR SHALL TAKE ALL PRECAUTIONS AND MAKE ALL INVESTIGATIONS NECESSARY TO PERFORM THE WORK. THE OWNER WILL NOT CONSIDER UNFAMILIARITY WITH THE PROJECT AS A BASIS FOR ADDITIONAL COMPENSATION.
4. CONTRACTOR SHALL REVIEW THE DIMENSIONS, DESIGN DRAWINGS AND SCALES WITH ACTUAL FIELD CONDITIONS. IN THE EVENT OF ANY DISCREPANCY, THE CONTRACTOR SHALL STOP OPERATION IMMEDIATELY, AND NOTIFY THE ENGINEER.

**PROTECTION NOTES:**

1. ADEQUATE PROTECTION OF PERSONS AND PROPERTY SHALL BE PROVIDED AT ALL TIMES. THE WORK SHALL BE EXECUTED IN SUCH A WAY AS TO AVOID HAZARD TO PERSONS AND PROPERTY. WORK SHALL BE ACCOMPLISHED IN ACCORDANCE WITH THE REQUIREMENTS OF LOCAL, STATE AND FEDERAL AUTHORITIES HAVING JURISDICTION OVER THE WORK.
2. PROVIDE ALL NECESSARY TEMPORARY PROTECTION AND BARRIERS TO SEGREGATE THE WORK AREA AND TO PREVENT DAMAGE TO ADJACENT AREAS.
3. PROVIDE PROPER PROTECTION AND BARRIERS BETWEEN THE WORK OF THE CONTRACT AND THE EXISTING STRUCTURES TO REMAIN.
4. PROVIDE MAXIMUM SECURITY IN TERMS OF PREVENTION OF FIRE AND OTHER HAZARDS.

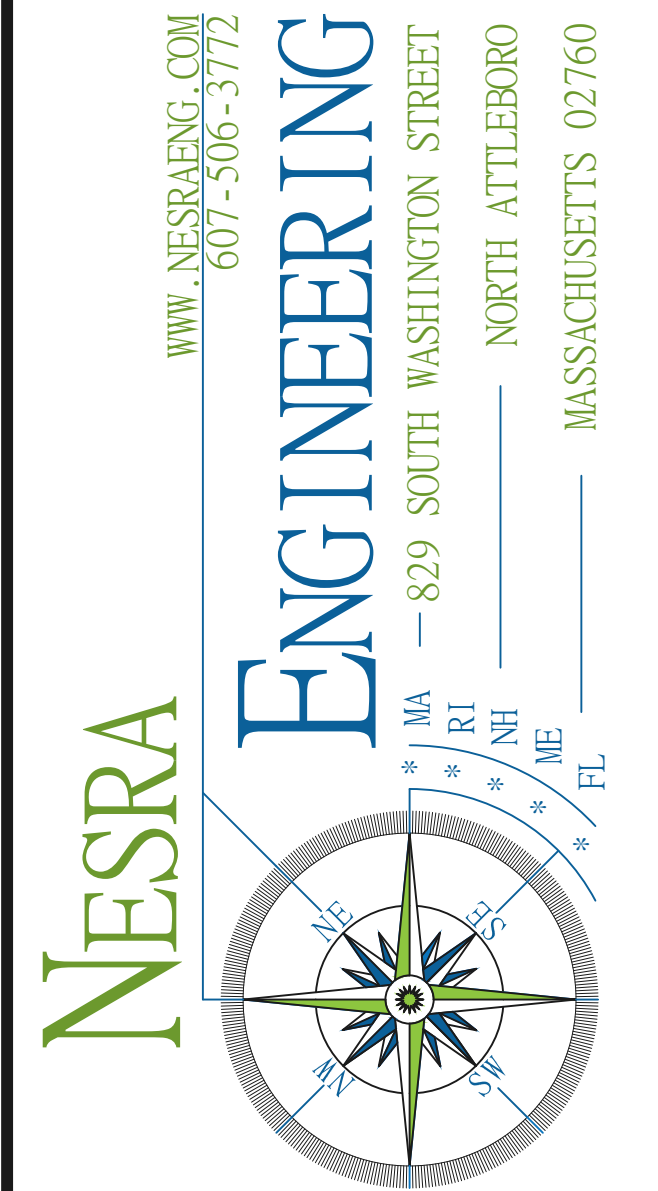

**PROJECT**

LA SALLE ACADEMY JOHN P. CRONIN FIELD RENOVATION PROJECT, 612 ACADEMY AVE, PROVIDENCE, RI 02908

**CLIENT**

LA SALLE ACADEMY 612 ACADEMY AVE PROVIDENCE, RI 02908

**BID SET**

NO.	REVISION	DATE
-----	----------	------

SCALE - AS NOTED  
DATE - 9/15/25

PROFESSIONAL SEAL

**GENERAL NOTES**

**C-2**

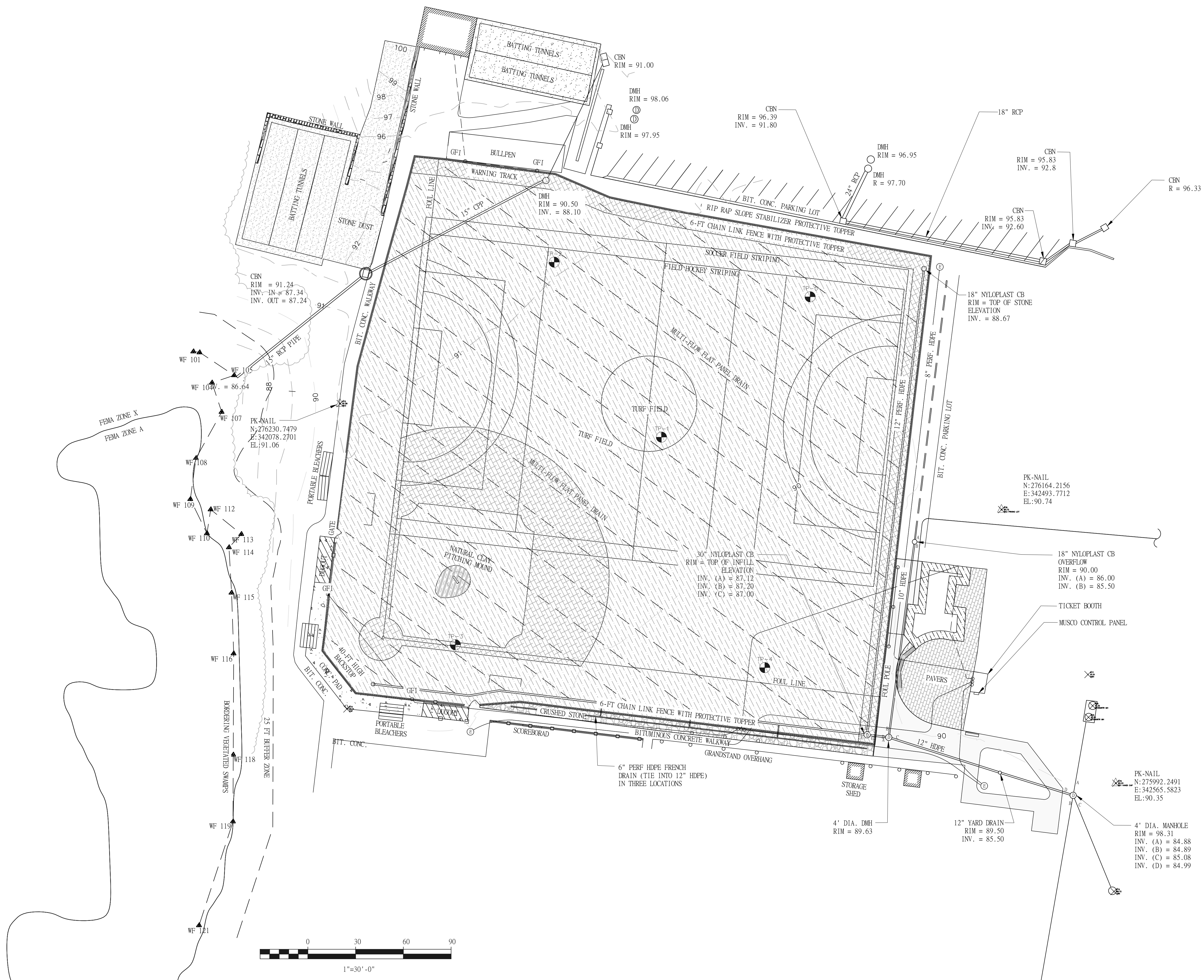

PROJECT  
 LA SALLE ACADEMY JOHN  
 P. CRONIN FIELD  
 RENOVATION PROJECT,  
 612 ACADEMY AVE,  
 PROVIDENCE, RI 02908

CLIENT  
 LA SALLE ACADEMY  
 612 ACADEMY AVE  
 PROVIDENCE, RI 02908

**BID SET**

NO.	REVISION	DATE

SCALE - AS NOTED  
 DATE - 9/15/25

PROFESSIONAL SEAL

EXISTING  
 CONDITIONS  
 PLAN

**C-3**

DEMOLITION LEGEND

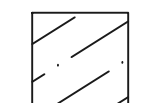
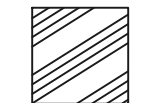
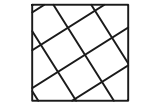
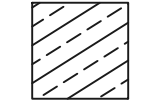
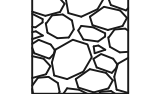
-  LIMITS OF SYNTHETIC TURF AND INFILL MATERIAL TO BE REMOVED AND DISPOSED.
-  LIMITS OF BITUMINOUS CONCRETE ASPHALT TO BE REMOVED AND DISPOSED.
-  LIMITS OF CONCRETE SURFACING TO BE REMOVED AND DISPOSED.
-  LIMITS OF LOAM TO BE REMOVED AND DISPOSED.
-  LIMITS OF STABILIZED CONSTRUCTION ENTRANCE MATERIAL PER DETAILS.

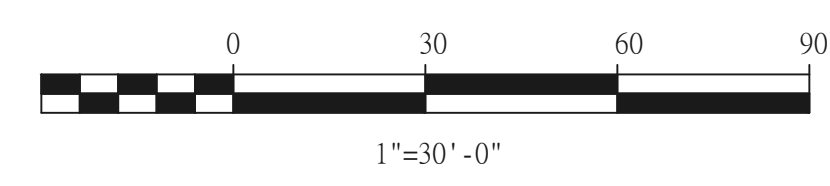
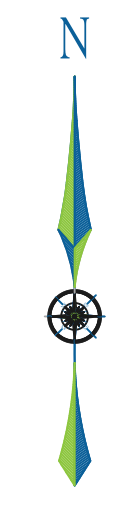
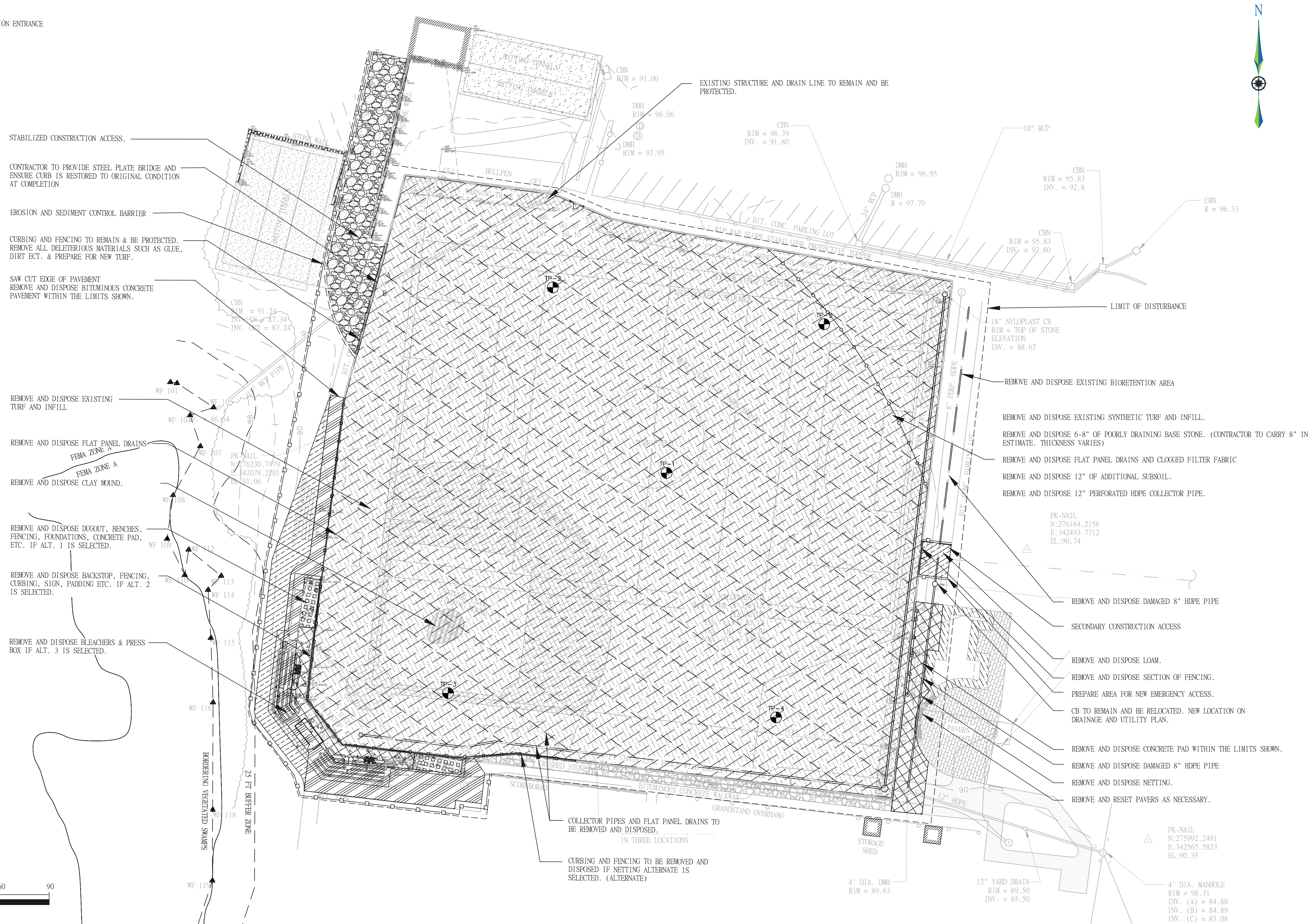

WWW.NESRAENG.COM  
 607-506-3772  
**NESRA ENGINEERING**  
 829 SOUTH WASHINGTON STREET  
 NORTH ATTLEBORO  
 MASSACHUSETTS 02760

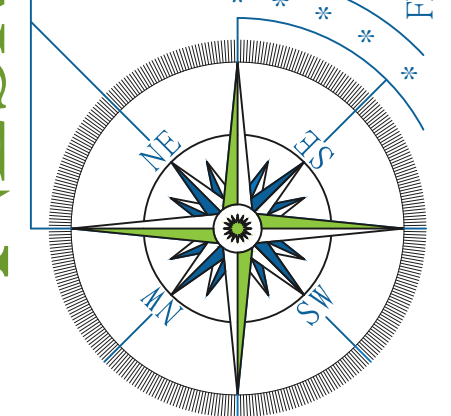

PROJECT  
**LA SALLE ACADEMY JOHN P. CRONIN FIELD RENOVATION PROJECT,**  
 612 ACADEMY AVE,  
 PROVIDENCE, RI 02908

CLIENT  
 LA SALLE ACADEMY  
 612 ACADEMY AVE  
 PROVIDENCE, RI 02908

**BID SET**

NO.	REVISION	DATE

SCALE - AS NOTED  
 DATE - 9/15/25

PROFESSIONAL SEAL  
**DEMOLITION AND EROSION CONTROL PLAN**

**C-4**

NOTE:

THE REMOVAL OF EXISTING SYNTHETIC TURF AND INFILL, INSTALLATION OF NEW PAD, AND THE SUPPLY AND INSTALLATION OF NEW SYNTHETIC TURF AND INFILL WILL BE COMPLETED BY GEOSURFACES UNDER A DIRECT CONTRACT WITH THE SCHOOL.

CONTRACTORS ARE REQUIRED TO COORDINATE WITH GEOSURFACES FOR THE TURF INSTALLATION. HOWEVER, THE COST OF MATERIALS AND INSTALLATION OF TURF AND INFILL SHALL NOT BE INCLUDED IN THE CONTRACTOR'S BID.

LIST OF ALTERNATES:

ALT 1. - DUGOUTS, INCLUDING SEATING, CUBBIES, BAT BOXES, FOUNDATIONS, FENCING, ETC. VISITOR SIDE SHALL CONSIST OF A 32-FT DUGOUT WITH ADDITIONAL 6-FT CLOSET. HOME SIDE SHALL CONSIST OF A 32-FT DUGOUT WITH ADDITIONAL 6-FT CLOSET AS MANUFACTURED BY SPORTSFIELD SPECIALTIES.

ALT 2. - 60-FT HIGH BACKSTOP NETTING SYSTEM WITH INTEGRATED PAD, INCLUDING ALL STAMPED STRUCTURAL PLANS, FOUNDATIONS, ETC.

ALT 3. - GRANDSTANDS WITH PRESS BOX, RAMPS, STAIRS, CONCRETE PAD, AND ALL ASSOCIATED ELECTRICAL WORK.

ALT 4. - PROVIDE 8 LED MUSCO LIGHT POLE FOUNDATIONS ONLY WITH CONDUITS AND PULL STRING AS WELL AS CONDUITS, COMM BOXES, AND PULL STRING FOR OUTLETS, COMMUNICATIONS, AND PA SYSTEM.

ALT 5. - TWO-POLE LED MUSCO LIGHTING SYSTEM FOR SOCCER PRACTICE AND FUTURE BASEBALL FIELD EXPANSION, DESIGNED TO MEET DARK SKIES STANDARDS AS WELL AS WIRING FOR OUTLETS, COMMUNICATIONS, AND PA SYSTEM.

ALT 6. - ADDITIONAL 6 LED MUSCO POLES FOR THE REMAINING BASEBALL LIGHTING SYSTEM AS WELL AS ALL WIRING AND POWER REQUIREMENTS FOR A FULLY OPERATIONAL LIGHTING SYSTEM.

ALT 7. - 40-FT HIGH TENSIONED NETTING SYSTEM.

ALT 8. - 60-FT HIGH TENSIONED NETTING SYSTEM. ~~COST INCREASE FROM 40 FT TO 60 FT.~~

ALT 7 - REVISED TO SAND BLAST, REPAIR, AND PAINT EXISTING NETTING POLES.  
 ALT 8 - REMOVE/DISPOSE EXISTING NETTING SYSTEM. PROVIDE NEW 60-FT NETTING SYSTEM.  
 ALT 9 - PROVIDE PA SYSTEM AND CONNECT TO EXISTING POWER AND COMMUNICATIONS. PA SYSTEM TO BE SUPPLIED BY SCOREBOARD SPECIALTIES. REFER TO SPECIFICATIONS FOR MORE DETAILS.

CONTRACTOR SHALL LASER GRADE BASE STONE TO PROPOSED ELEVATION. PERFORM TESTING, INCLUDING PLANARITY AND INFILTRATION TESTING AND GRID SURVEY. SUBMIT TESTING INFORMATION TO ENGINEER FOR REVIEW. TURF SHALL NOT BE INSTALLED UNTIL WRITTEN APPROVAL OF THE BASE MATERIAL.

NATURAL CLAY MOUND (RED)

ALT 1. - DUGOUTS, INCLUDING SEATING, CUBBIES, BAT BOXES, FOUNDATIONS, FENCING, ETC. DUGOUT ROOF SHALL MATCH EXISTING FIELD HOUSE METAL ROOF. (COLONIAL RED) HOME DUGOUT SHALL BE 36 FT LONG WITH 8 X 6 CLOSET. VISITOR DUGOUT SHALL BE 32 FT LONG WITH 8 X 6 CLOSET.

ALT 2. - 60-FT HIGH CUSTOM POLE TO POLE TENSION BACKSTOP NETTING SYSTEM WITH INTEGRATED WALL PAD BACKSTOP AND ULTRA CROSS NET, INCLUDING ALL STAMPED STRUCTURAL PLANS, FOUNDATIONS, ETC. AS MANUFACTURED BY SPORTSFIELD SPECIALTIES. END WALL PAD AT DUGOUT, CONTINUE NETTING AS SHOWN.

ALT 3. - GRANDSTANDS WITH PRESS BOX, RAMPS, STAIRS, CONCRETE PAD, AND ALL ASSOCIATED ELECTRICAL WORK. GRANDSTAND AND PRESS BOX AS SUPPLIED BY GALLIVAN COMPANY.

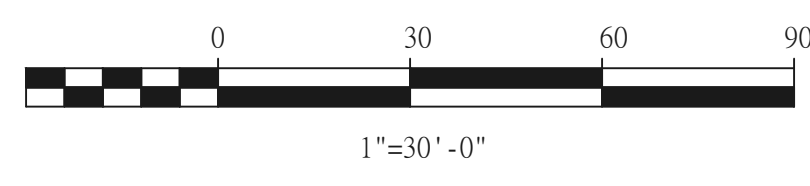
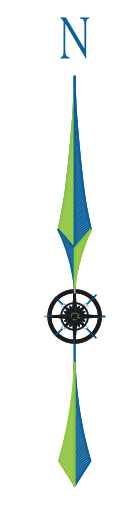
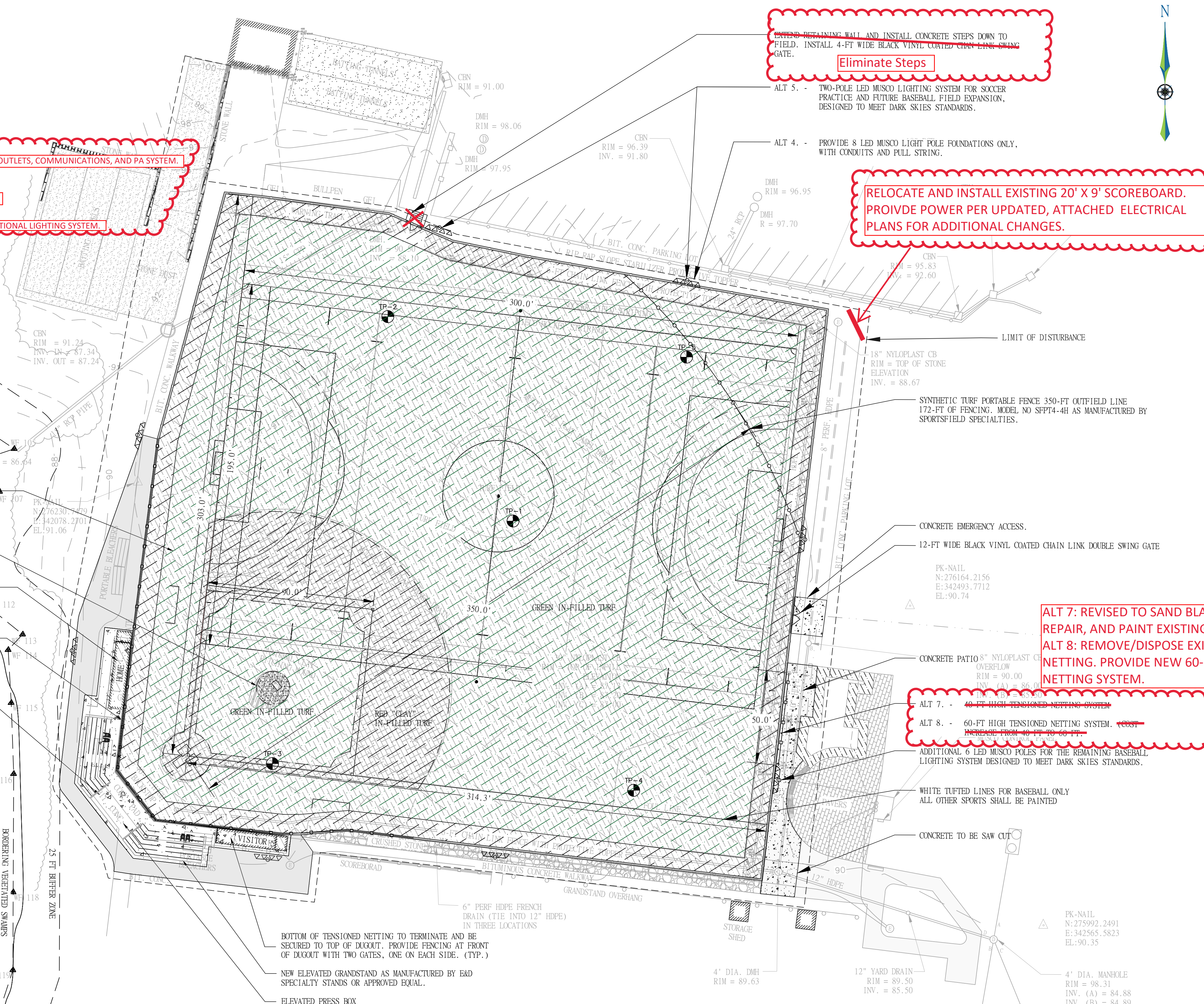

www.nesraeng.com  
607-506-3772

**NESRA ENGINEERING**

MA 829 SOUTH WASHINGTON STREET  
RI NORTH ATTLEBORO  
NH MASSACHUSETTS 02760

ARSEN HAMBARDZUMIAN

No. 9734

REGISTERED PROFESSIONAL ENGINEER

PROJECT

LA SALLE ACADEMY JOHN P. CRONIN FIELD RENOVATION PROJECT, 612 ACADEMY AVE, PROVIDENCE, RI 02908

CLIENT

LA SALLE ACADEMY 612 ACADEMY AVE PROVIDENCE, RI 02908

**BID SET**

NO.	REVISION	DATE

SCALE - AS NOTED  
 DATE - 9/15/25

PROFESSIONAL SEAL

LAYOUT AND MATERIALS PLAN

**C-5**

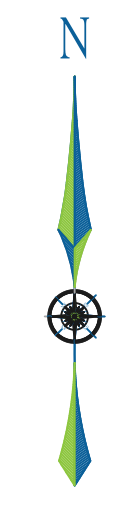
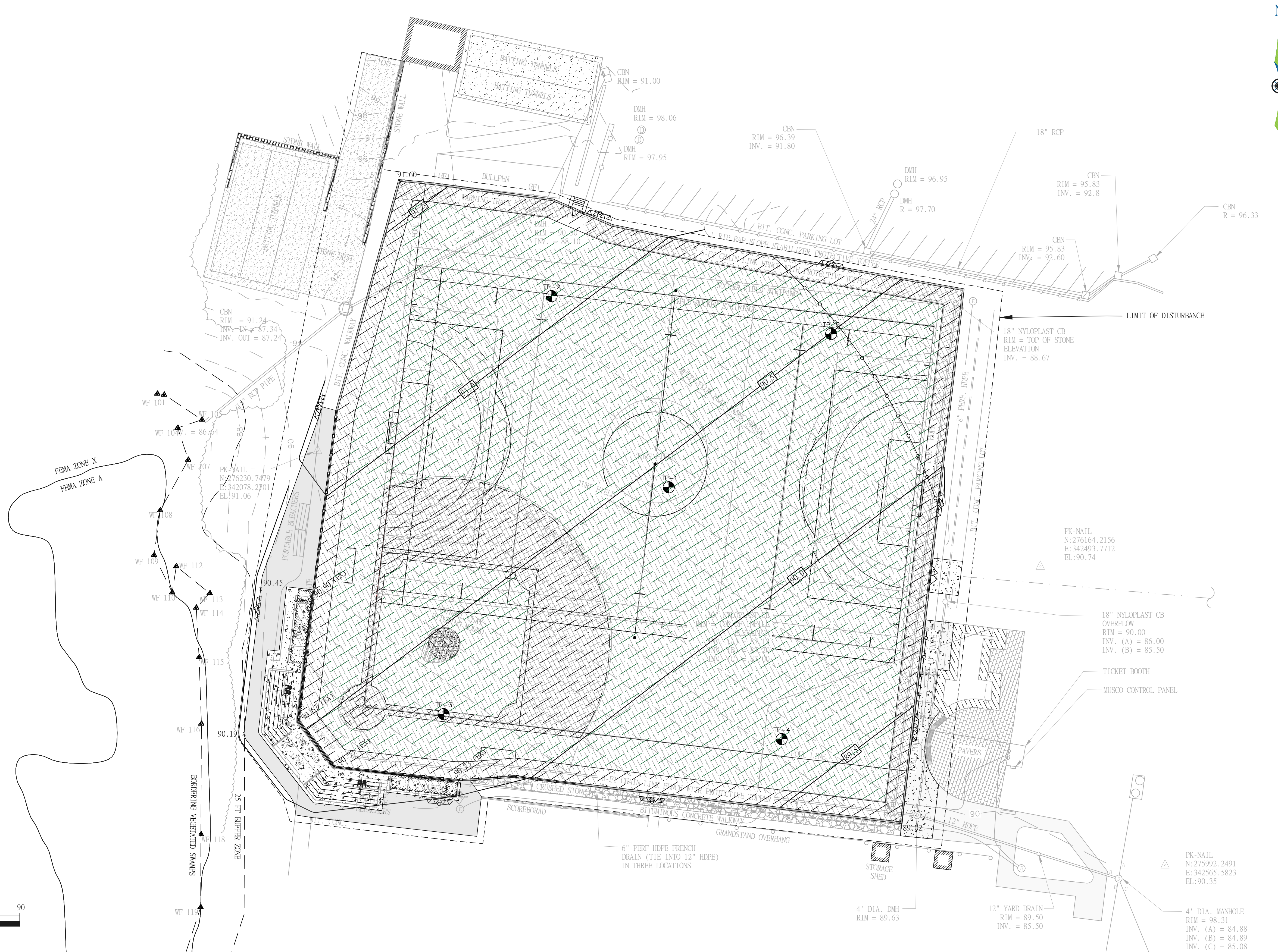
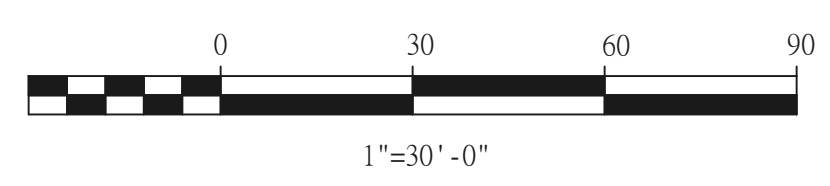

WWW.NESRAENG.COM  
 607-506-3772  
**NESRA ENGINEERING**  
 829 SOUTH WASHINGTON STREET  
 NORTH ATTLEBORO  
 MASSACHUSETTS 02760



**PROJECT**  
 LA SALLE ACADEMY JOHN  
 P. CRONIN FIELD  
 RENOVATION PROJECT,  
 612 ACADEMY AVE,  
 PROVIDENCE, RI 02908

**CLIENT**  
 LA SALLE ACADEMY  
 612 ACADEMY AVE  
 PROVIDENCE, RI 02908

**BID SET**

NO.	REVISION	DATE

SCALE - AS NOTED  
 DATE - 9/15/25

PROFESSIONAL SEAL

**GRADING PLAN**

**C-6**

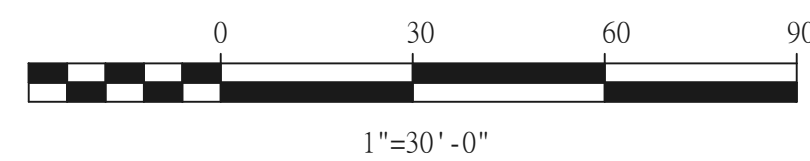

PROJECT  
 LA SALLE ACADEMY JOHN  
 P. CRONIN FIELD  
 RENOVATION PROJECT,  
 612 ACADEMY AVE,  
 PROVIDENCE, RI 02908

CLIENT  
 LA SALLE ACADEMY  
 612 ACADEMY AVE  
 PROVIDENCE, RI 02908

**BID SET**

NO.	REVISION	DATE

SCALE - AS NOTED  
 DATE - 9/15/25

PROFESSIONAL SEAL

**DRAINAGE AND UTILITY PLAN**

**C-7**

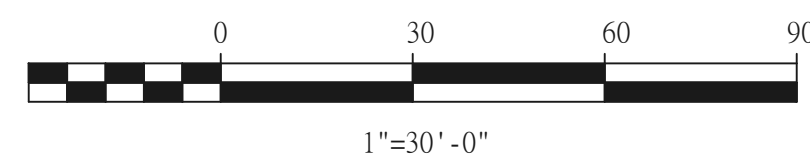

**PROJECT**  
 LA SALLE ACADEMY JOHN  
 P. CRONIN FIELD  
 RENOVATION PROJECT,  
 612 ACADEMY AVE,  
 PROVIDENCE, RI 02908

**CLIENT**  
 LA SALLE ACADEMY  
 612 ACADEMY AVE  
 PROVIDENCE, RI 02908

NO.	REVISION	DATE
1.	UPDATED PERIMETER DRAINAGE PIPE & NYLOPLAST SIZES	1/5/26

SCALE - AS NOTED  
 DATE - 9/15/25

PROFESSIONAL SEAL

**DRAINAGE AND UTILITY PLAN**

**C-7A**

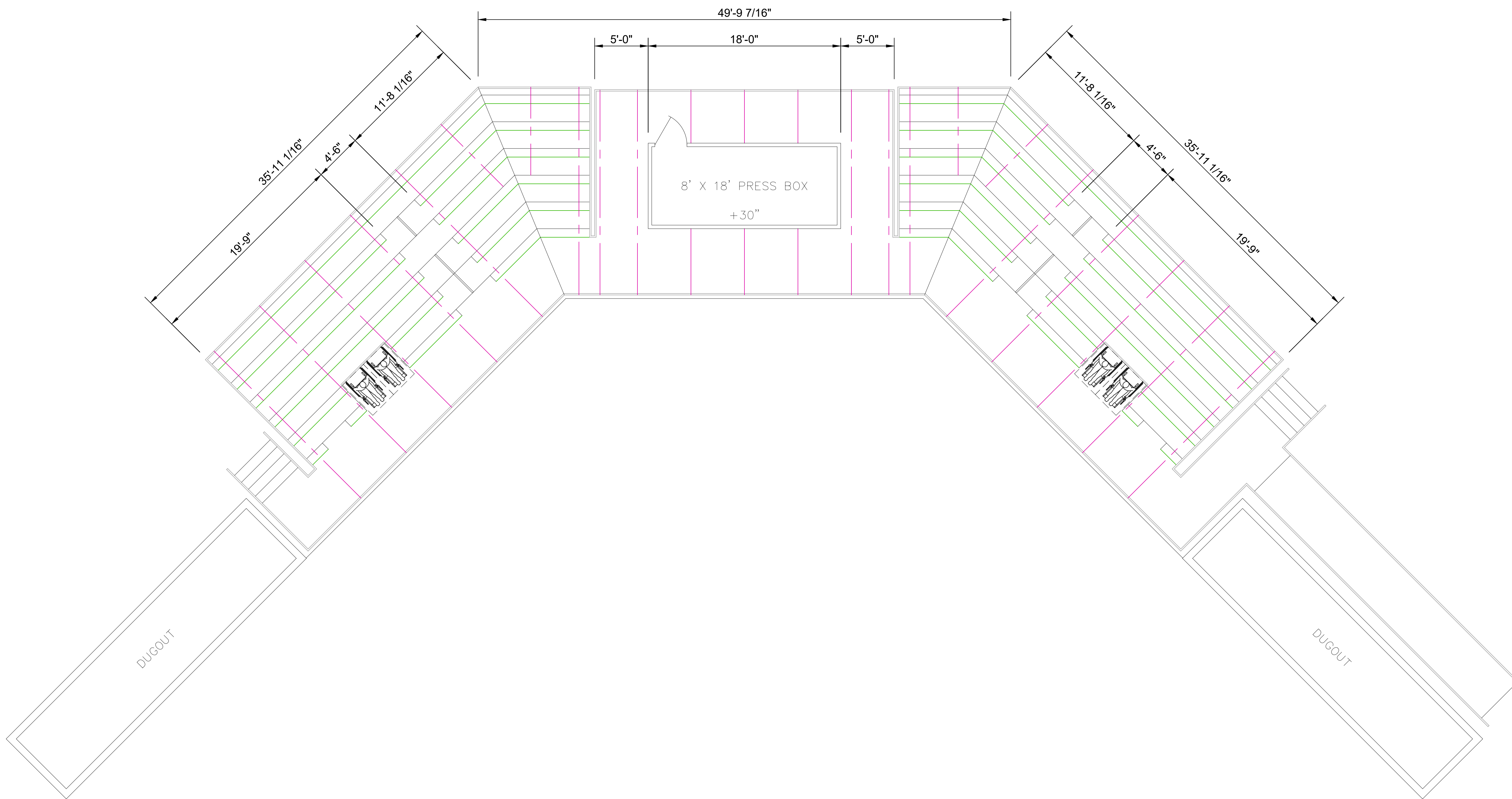

SEATING MANIFEST	
Bench Seating:	246
Wheelchair Seating:	4
Companion Seating:	4
<b>Total:</b>	<b>254</b>

www.nesraeng.com  
 607-506-3772  
**ENGINEERING**  
 829 SOUTH WASHINGTON STREET  
 NORTH ATTLEBORO  
 MASSACHUSETTS 02760



PROJECT  
 LA SALLE ACADEMY JOHN  
 P. CRONIN FIELD  
 RENOVATION PROJECT,  
 612 ACADEMY AVE,  
 PROVIDENCE, RI 02908

CLIENT  
 LA SALLE ACADEMY  
 612 ACADEMY AVE  
 PROVIDENCE, RI 02908

**BID SET**

NO.	REVISION	DATE

SCALE - AS NOTED  
 DATE - 9/15/25

PROFESSIONAL SEAL

GRANDSTAND PLAN

**C-8**

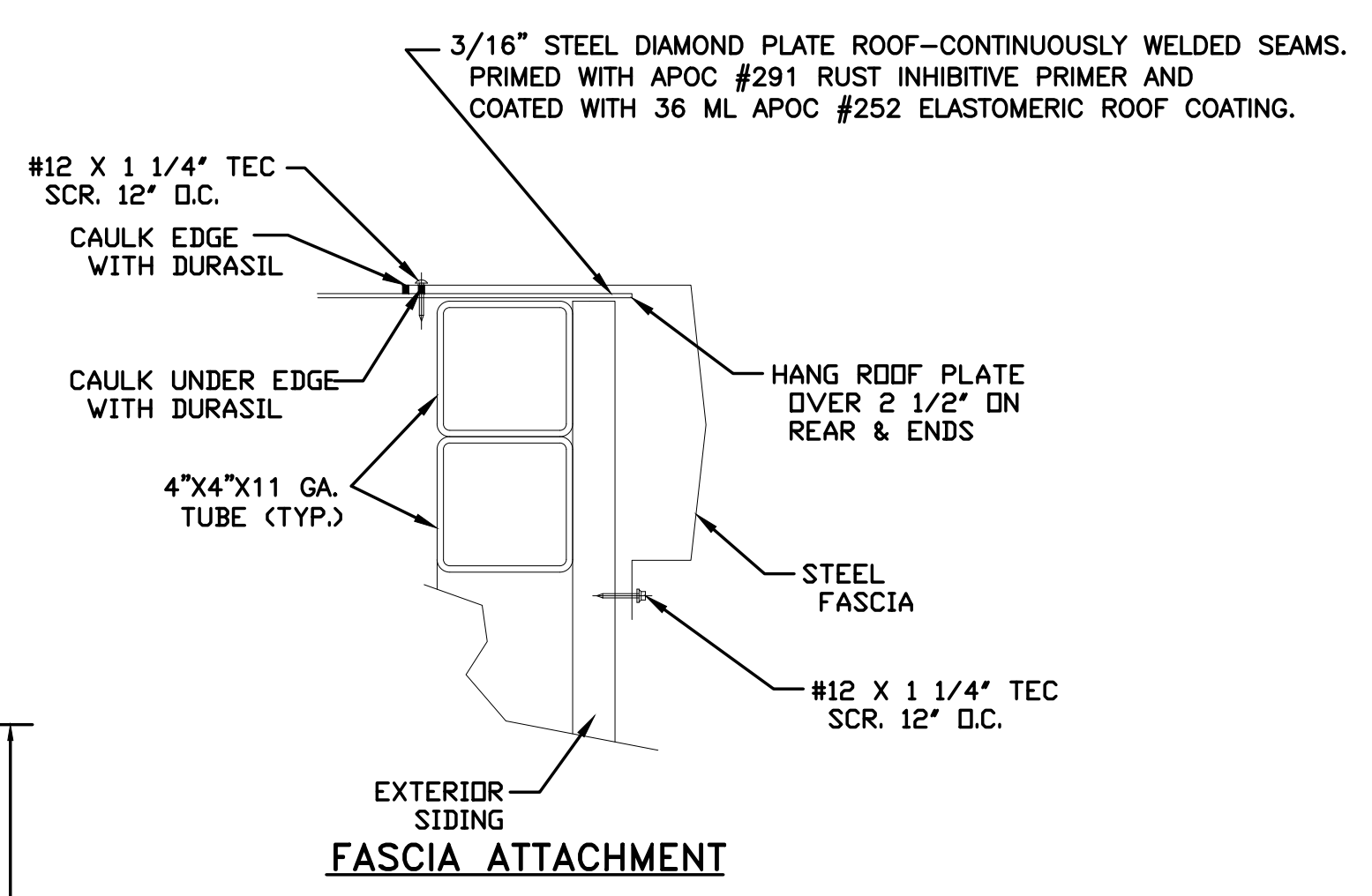
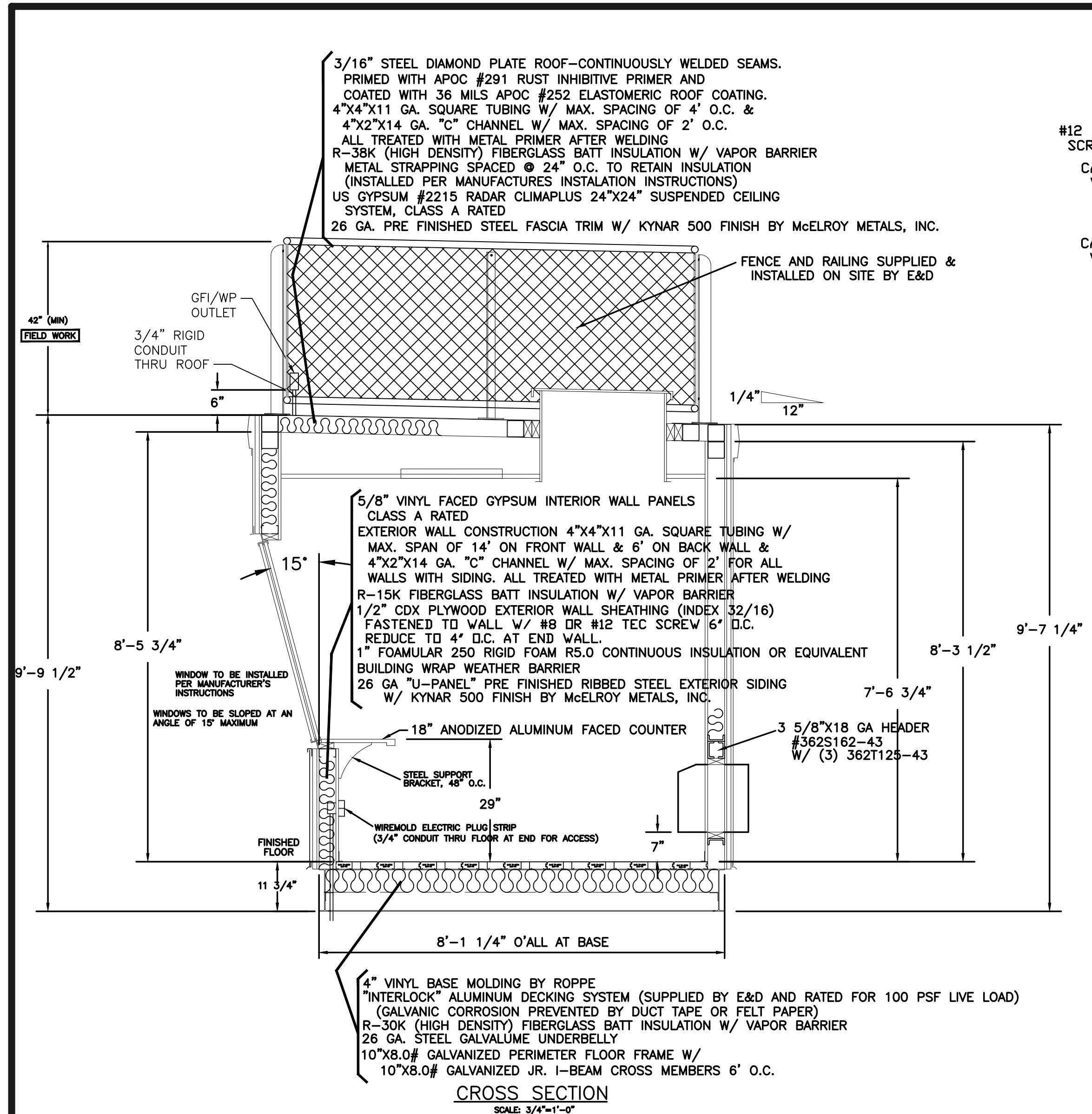

FINISH SCHEDULE	
INTERIOR:	COLOR:
VINYL FACED GYPSUM:	LOOMA BEIGE
BASE FLOOR MOLDING:	PEWTER
COUNTER:	ANODIZED ALUMINUM
INTERIOR WINDOW TRIM & CASING:	WHITE
EXTERIOR:	
SIDING:	---
FASCIA:	---
WINDOWS:	---
DOORS:	---
DOOR FRAMES:	---

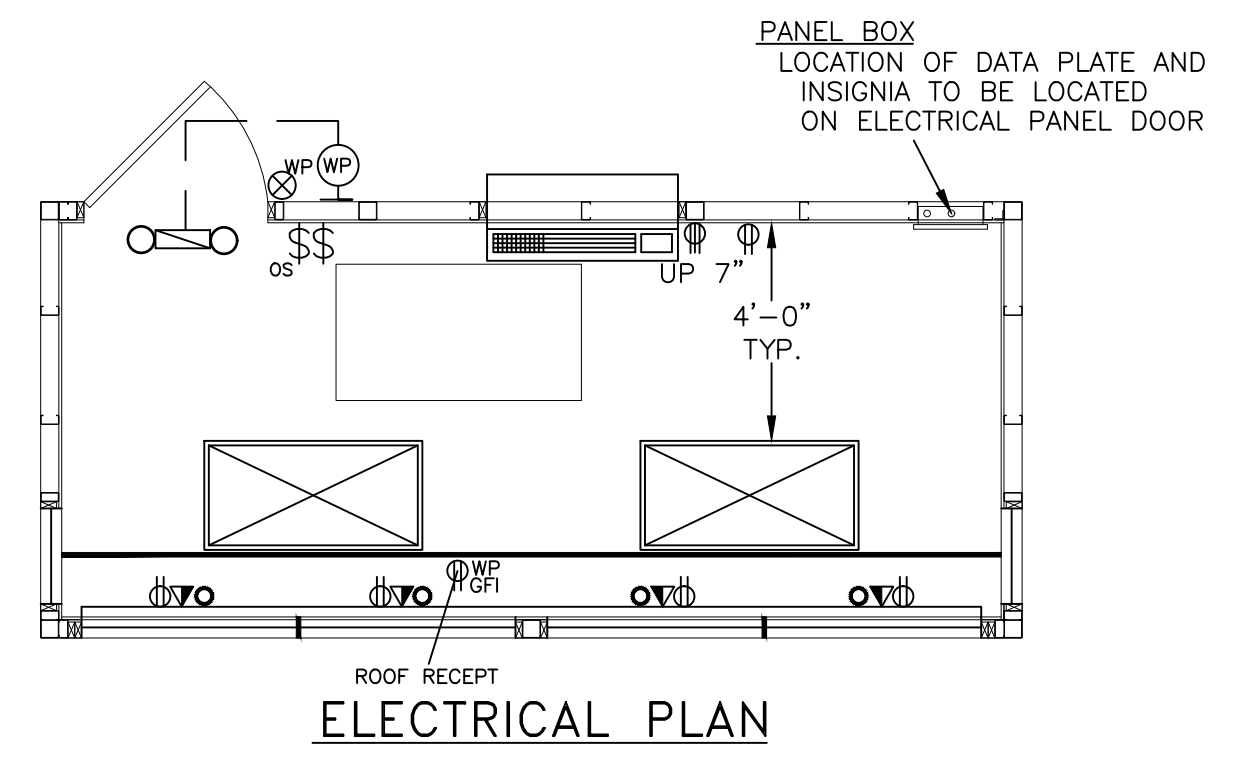
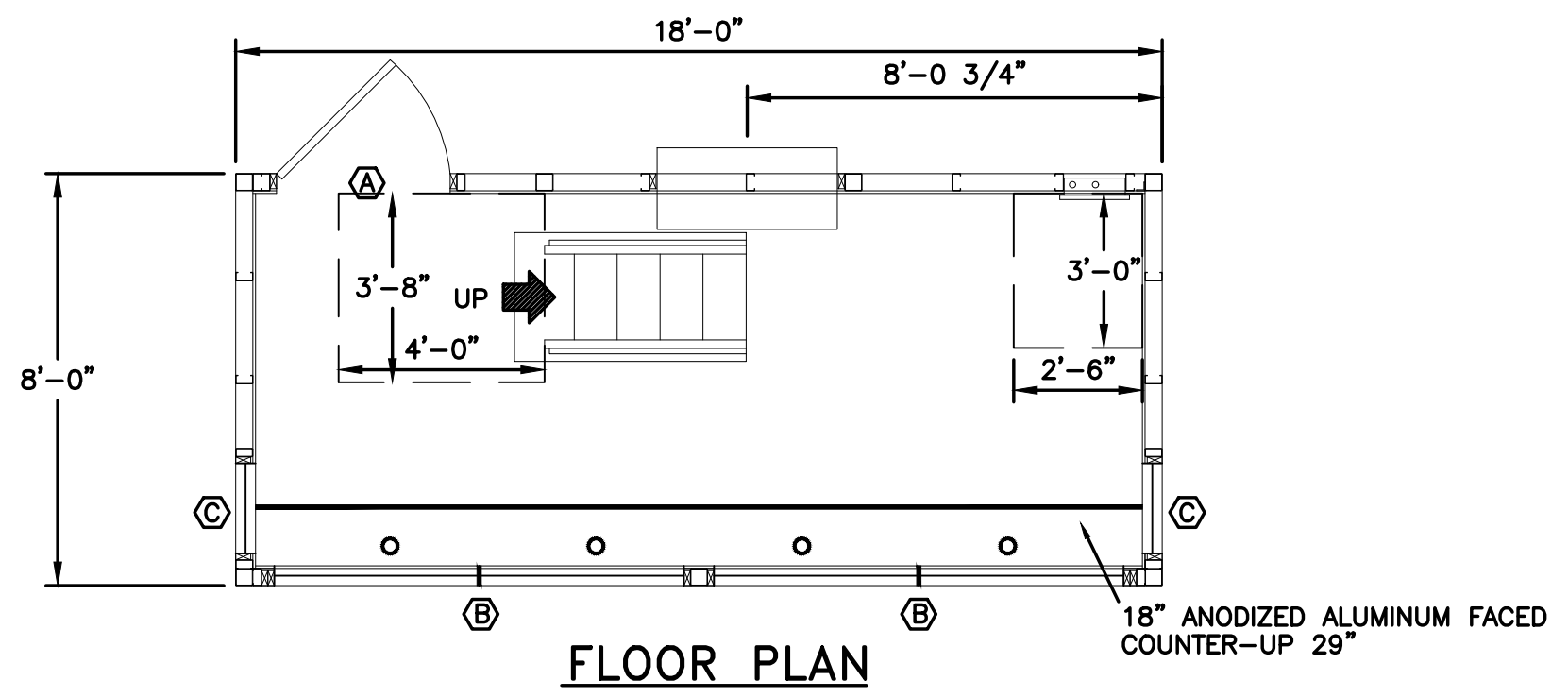
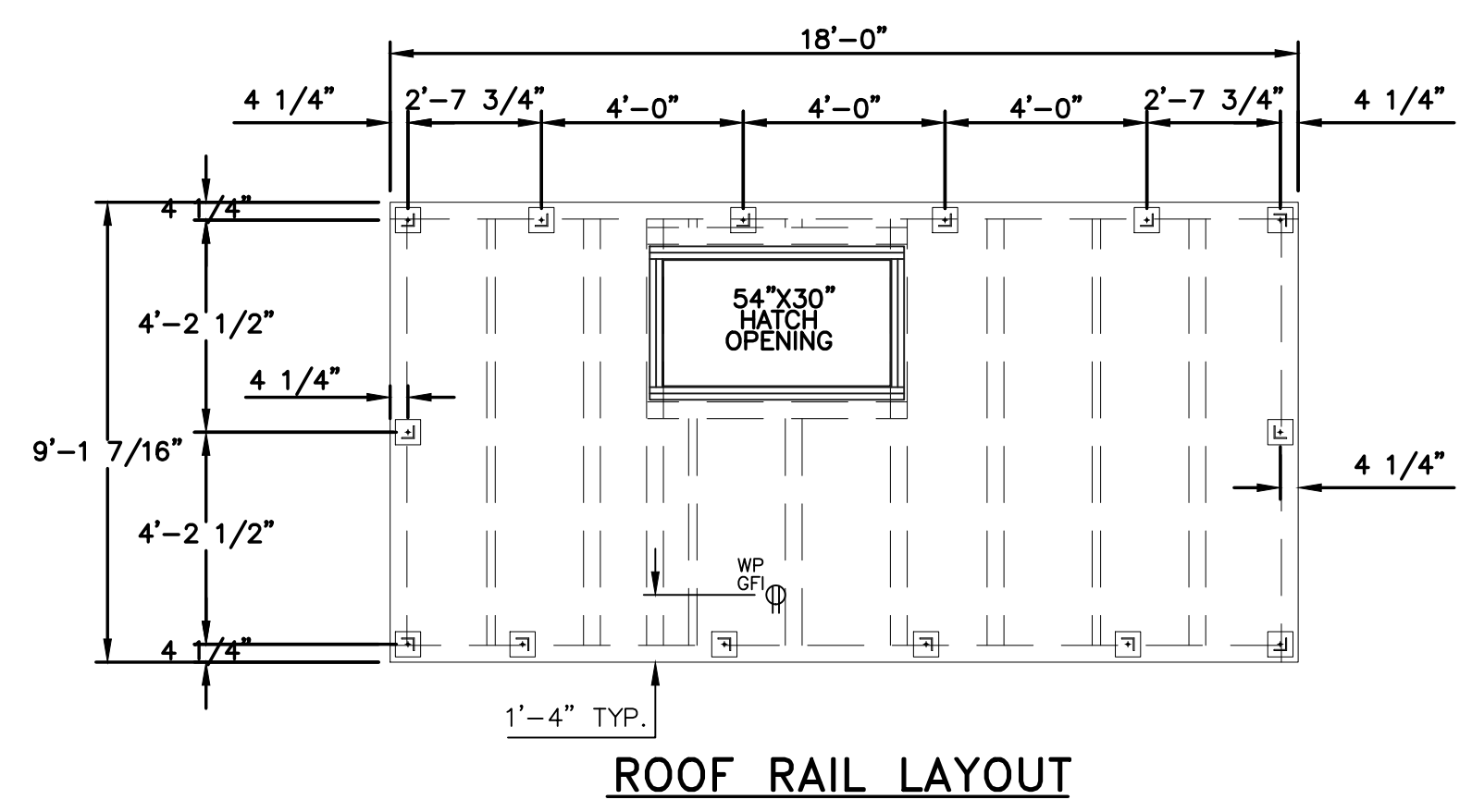

DOOR/WINDOW SCHEDULE	
SYMBOL	DISCRIPTION
(A)	36"x80" "SPECIAL-LITE SERIES SL17" FRP (FIBERGLASS REINFORCED PLASTIC) DOOR W/ ALUMINUM FRAMES, HYDRAULIC CLOSER, WEATHERSTRIP, 10" LITE, ALUMINUM THRESHOLD AND COMMERCIAL LEVER HANDLED LOCKSET (40 1/2" X 82 1/2" ROUGH OPENING) (ADA THRESHOLD) U-VALUE=.31
(B)	(2)46 7/8"x48" WOJAN #M-85 SERIES ALUMINUM FRAMED SINGLE-HUNG VERTICAL SLIDER WINDOW W/ 3/4" INSULATED SUNGUARD SNX 62/27 LOW-E, ARGON FILLED TEMPERED SAFETY GLASS AND SCREENS (UNIT SIZE: 94 1/2" X 48" WINDOW) (ROUGH OPENING: 95 1/2" X 48 1/2") U-VALUE=.20 SHGC=.25
(C)	WOJAN #M-85 SERIES ALUMINUM FRAMED PICTURE WINDOW W/ 3/4" INSULATED SUNGUARD SNX 62/27 LOW-E, ARGON FILLED TEMPERED SAFETY GLASS (SEE DETAIL BELOW FOR DIMENSIONS) -MOUNT AT FRONT WINDOW HEADER HEIGHT U-VALUE=.20 SHGC=.25

ELECTRICAL LEGEND	
SYMBOL	DISCRIPTION
[Symbol]	RAB EZPAN2X4-40N/D10 0.35 AMP, 40 WATT EACH LED LIGHT FIXTURE
[Symbol]	LITHONIA #ECCR-HO-RD-M6 EMERGENCY COMBINATION EXIT/FLOOD LIGHT W/ MIN. 90 MINUTE BATTERY BACK-UP (WALL MOUNT)
[Symbol]	LITHONIA #ERE-GY-SGL-WP-RD-M12 REMOTE EMERGENCY LIGHT HEAD-SOFFIT MOUNTED (GRAY)
[Symbol]	WESTINGHOUSE #6106800 8 WATT LED EXTERIOR LIGHT FIXTURE W/ PHOTO CELL (WATERPROOF)
[Symbol]	PASS & SEYMOUR #TM870LA SPEC. GRADE, GROUNDING TYPE, SWITCH (IVORY)
[Symbol]	LUTRON #MSOPSSMLA, (1) POLE OCCUPANCY SENSOR SWITCH W/ MANUAL OVERRIDE (IVORY) -WALL MOUNTED
[Symbol]	PASS & SEYMOUR #3232-LA SPEC. GRADE, GROUNDING TYPE, RECEPT (IVORY) -GFI WERE NOTED -UP 18" UNLESS NOTED
[Symbol]	PASS & SEYMOUR #5851-LA 240 VOLT SPEC. GRADE, GROUNDING TYPE, RECEPT (LIGHT ALMOND) -WEATHER PROOF & GFI WHERE NOTED -UP 18" UNLESS NOTED
[Symbol]	ELECTRICAL DISTRIBUTION LOAD CENTER W/ MAIN DISCONNECT-120/240V., SINGLE PHASE, 100 AMP CAPACITY, SQ. 'D' #00112M100-UP 48" TO CENTER W/ (1) 1 1/2" EMT CONDUIT THRU FLOOR W/ (1) 3/4" EMT CONDUIT THRU FLOOR
[Symbol]	#5400 SERIES CONTINUOUS ELECTRIC WIREMOLD (IVORY) W/ RECEPTS AND COMMUNICATION JACK COVERS 48" O.C. AND 3/4" CONDUIT THRU FLOOR AT EACH END OF PRESSBOX FOR ACCESS-UP 14"
[Symbol]	2 1/2" GROMMETED HOLE THRU COUNTER
[Symbol]	ZONELINE #AZ45E07DAB 3.5 KW ELECTRIC WALL MOUNT HEAT/COOL UNIT W/ DRAIN KIT-UP 7" 7,200 BTU COOL 11,700 BTU HEAT

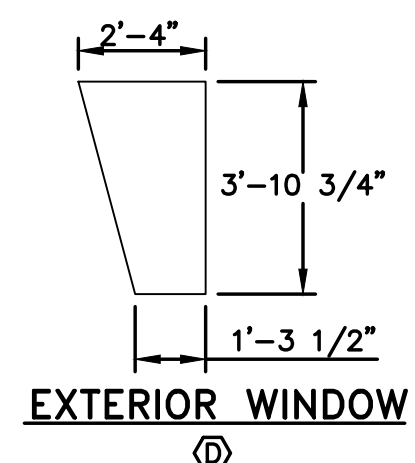
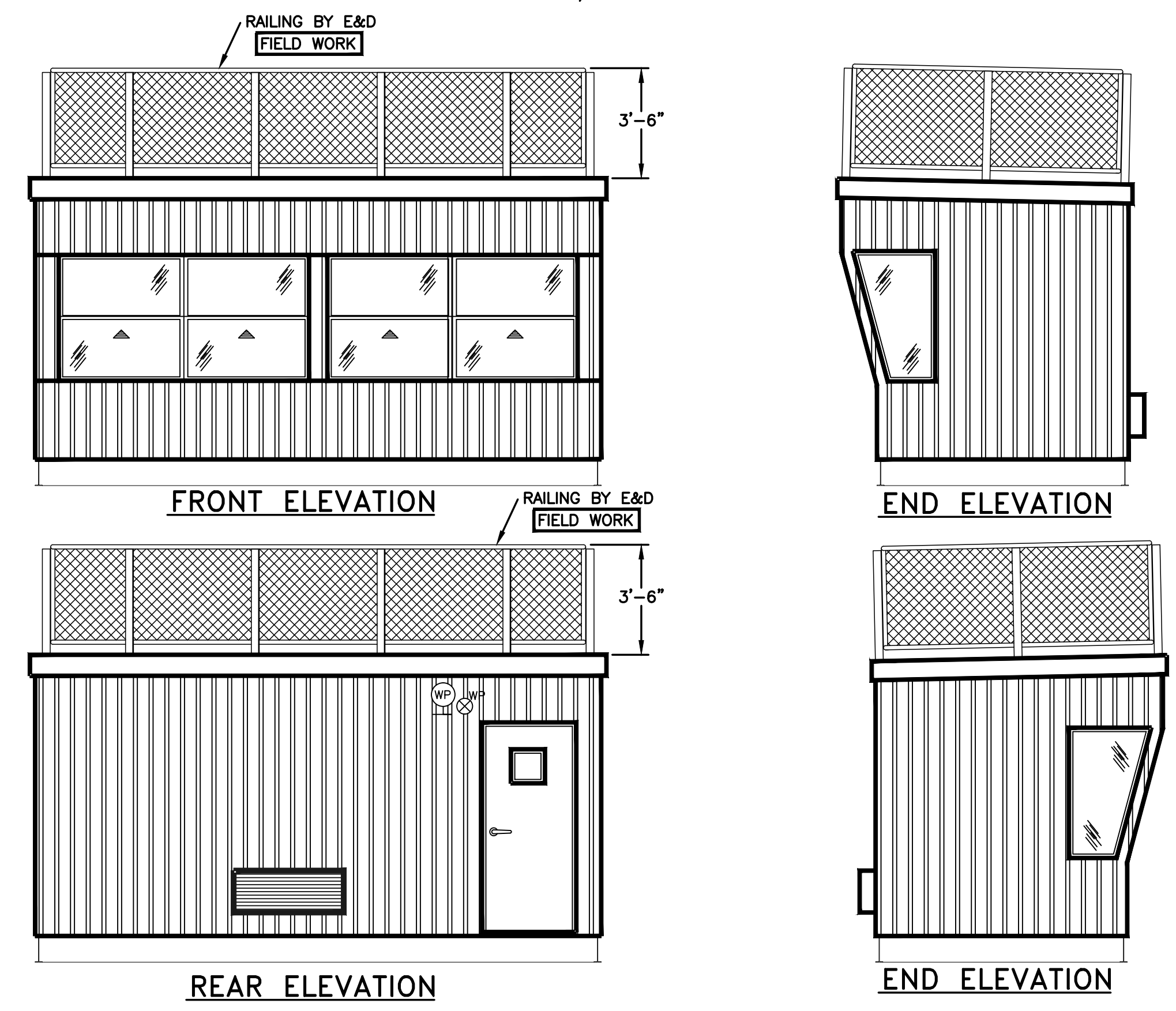

WWW.NESRAENG.COM  
607-506-3772

**NESRA ENGINEERING**

MASSACHUSETTS 02760  
NORTH ATTLEBORO  
829 SOUTH WASHINGTON STREET  
MA \* RI \* NH \* ME \* VT \* CT \* NY \* PA \* OH \* WV \* MD \* DE \* DC \* VA \* NC \* TN \* KY \* IN \* IL \* MI \* WI \* MN \* IA \* MO \* OK \* NE \* KS \* CO \* WY \* MT \* ND \* SD \* NEB \* S.D.

ARSEN HAMBARDZUMIAN  
No. 9734  
REGISTERED PROFESSIONAL ENGINEER

PROJECT  
LA SALLE ACADEMY JOHN P. CRONIN FIELD RENOVATION PROJECT, 612 ACADEMY AVE, PROVIDENCE, RI 02908

CLIENT  
LA SALLE ACADEMY 612 ACADEMY AVE PROVIDENCE, RI 02908

**BID SET**

NO.	REVISION	DATE

SCALE - AS NOTED  
DATE - 9/15/25

PROFESSIONAL SEAL

PRESS BOX PLAN

**C-9**

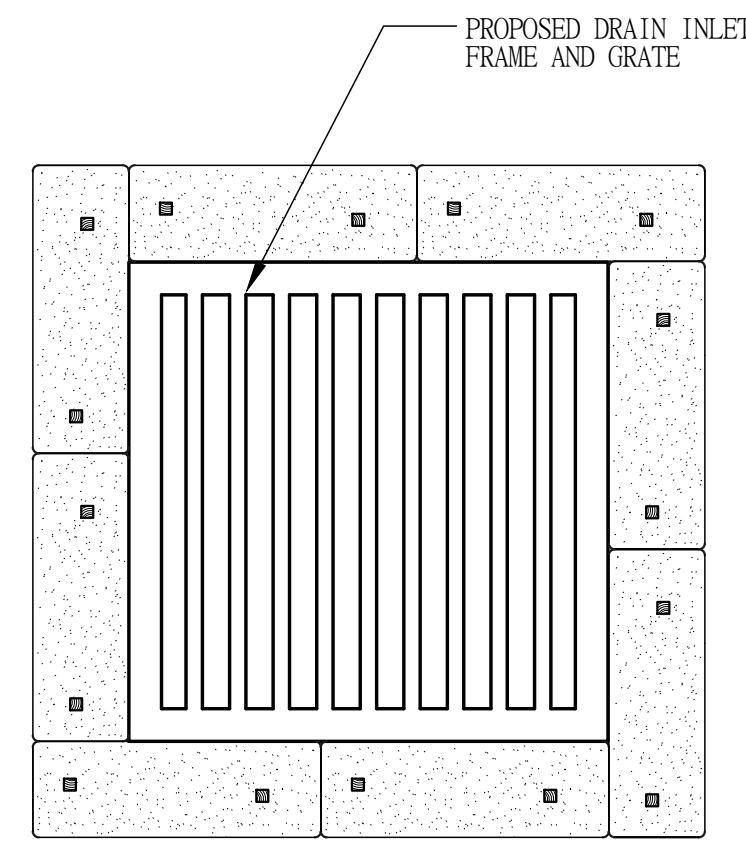

NOTES:

BALES SHALL BE PLACED IN A ROW WITH THE ENDS TIGHTLY ABUTTING THE ADJACENT BALES.

BALES SHALL BE SECURELY ANCHORED IN PLACE BY STAKES OR RE-BARS DRIVEN THROUGH THE BALES. THE FIRST STAKE IN EACH BALE SHALL BE ANGLED TOWARD PREVIOUSLY LAID BALE TO FORCE BALES TOGETHER.

INSPECTION SHALL BE FREQUENT AND REPAIR OR REPLACEMENT SHALL BE MADE PROMPTLY AS NEEDED.

**CATCH BASIN STRAW BALE FILTER DETAIL**  
N.T.S.

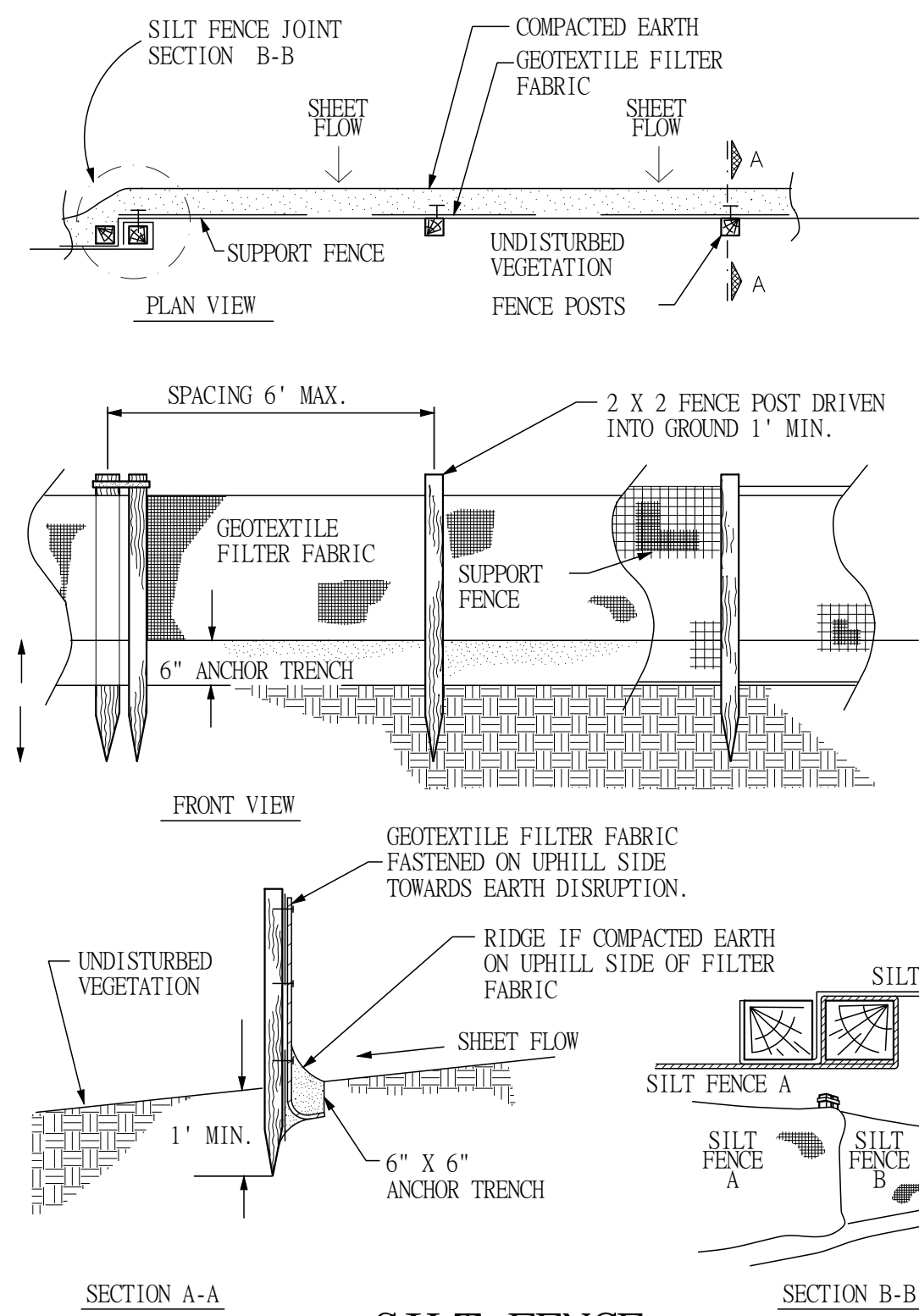

**SILT FENCE**  
N.T.S.

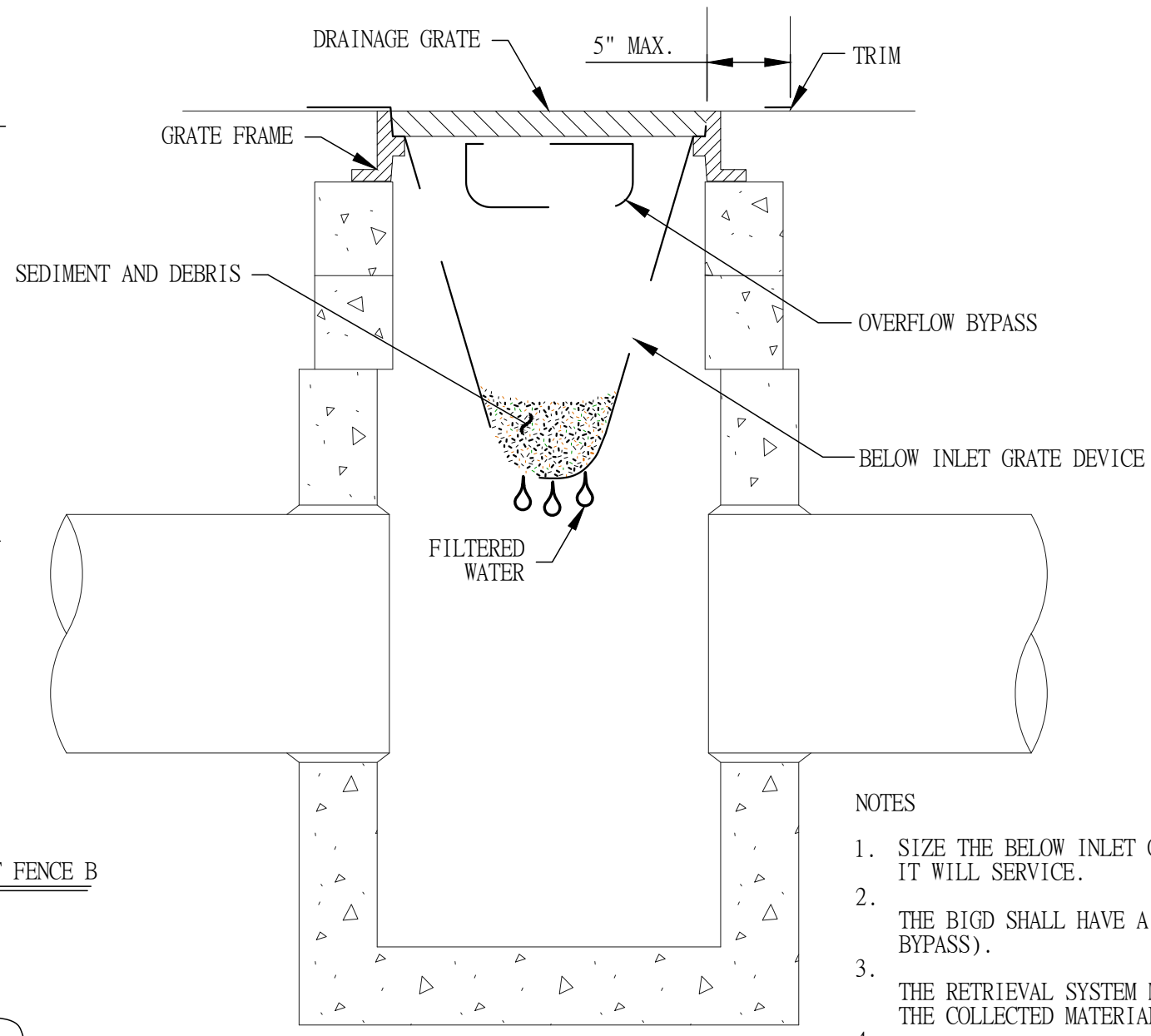

NOTES

1. SIZE THE BELOW INLET GRATE DEVICE (BIGD) FOR THE STORM WATER STRUCTURE IT WILL SERVICE.
2. THE BIGD SHALL HAVE A BUILT-IN HIGH-FLOW RELIEF SYSTEM (OVERFLOW BYPASS).
3. THE RETRIEVAL SYSTEM MUST ALLOW REMOVAL OF THE BIGD WITHOUT SPILLING THE COLLECTED MATERIAL.
4. PERFORM MAINTENANCE IN ACCORDANCE WITH STORMWATER POLLUTION PREVENTION PLAN, TO BE PREPARED BY THE CONTRACTOR.

**STORM DRAIN INLET PROTECTION**  
N.T.S.

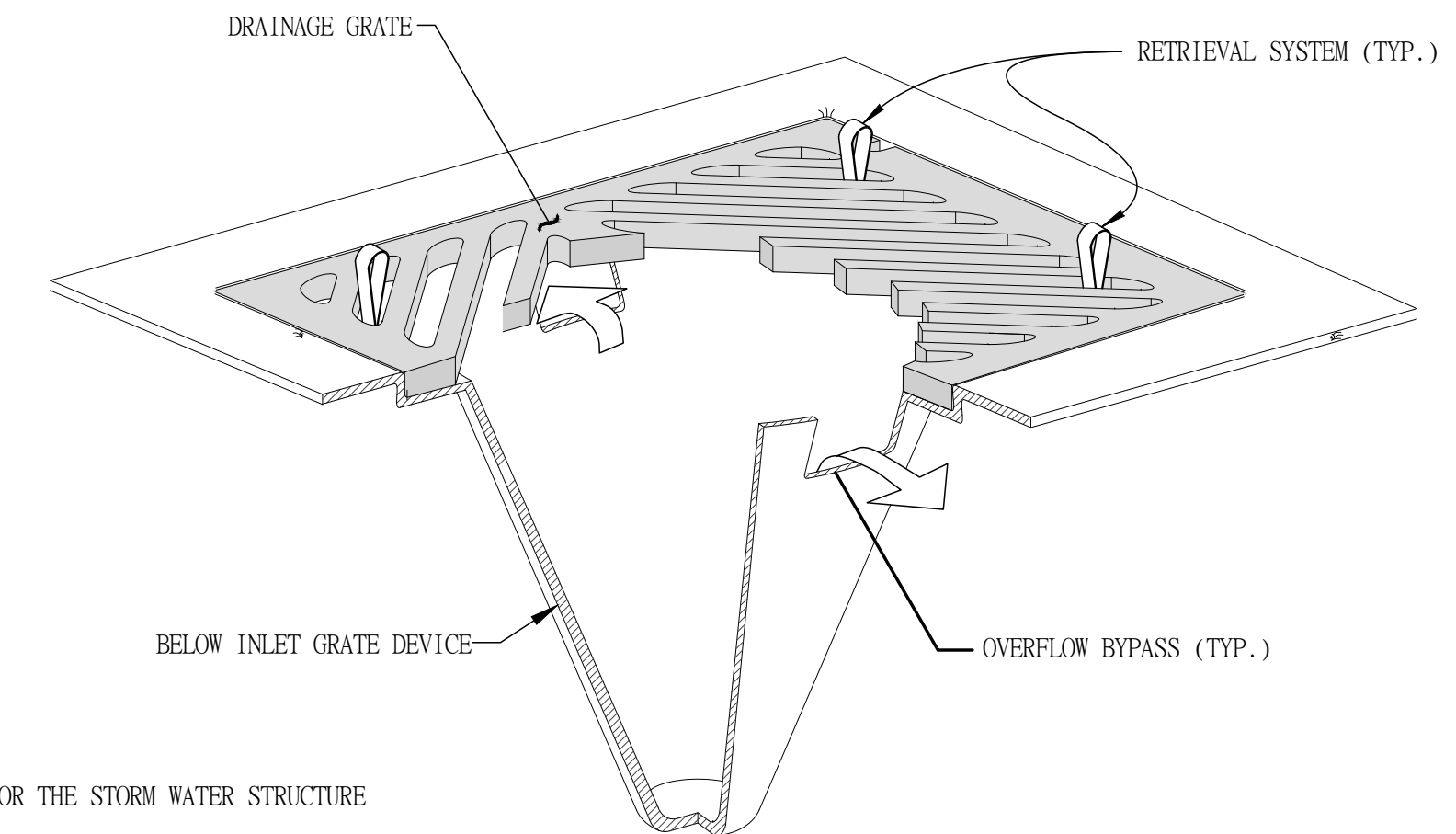

**ISOMETRIC VIEW**

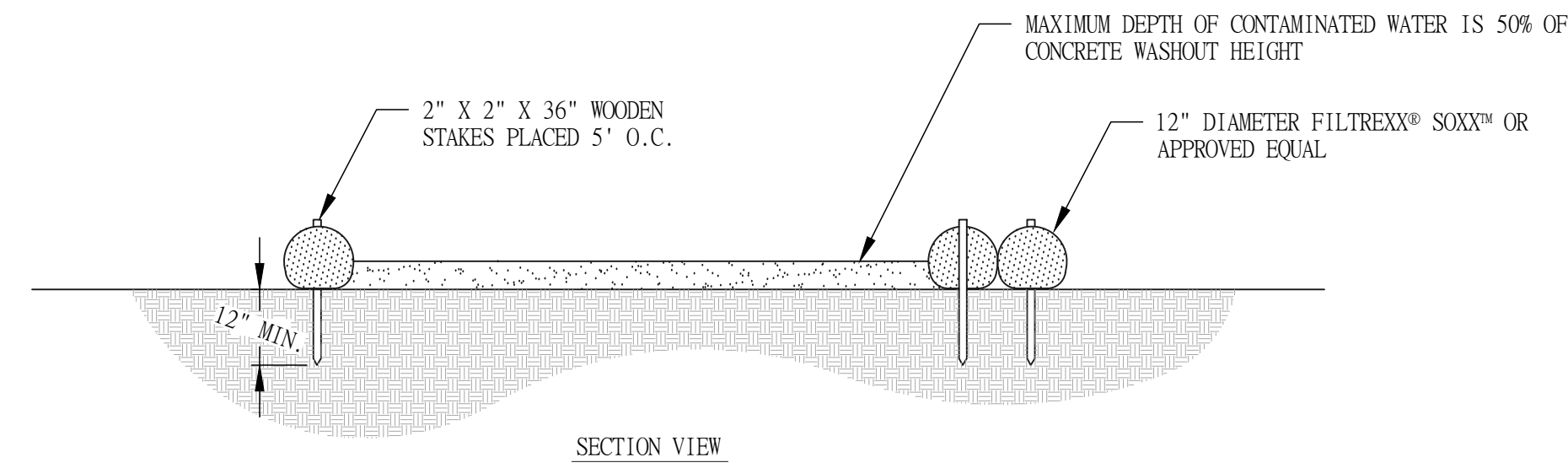
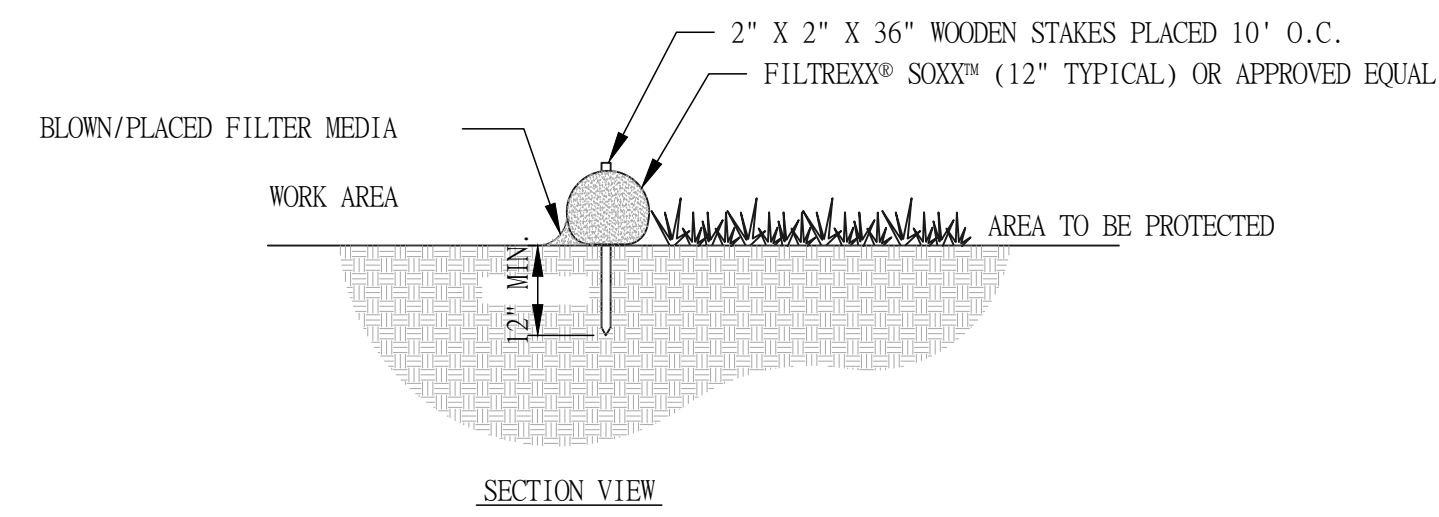

NOTES:

1. INSTALL ON FLAT GRADE FOR OPTIMUM PERFORMANCE
2. CONCRETE WASHOUT MAY BE STACKED IN A PYRAMIDAL CONFIGURATION FOR ADDED HEIGHT AND STABILITY
3. CONCRETE WASHOUT MAY BE DIRECT SEEDED AT THE TIME OF INSTALLATION

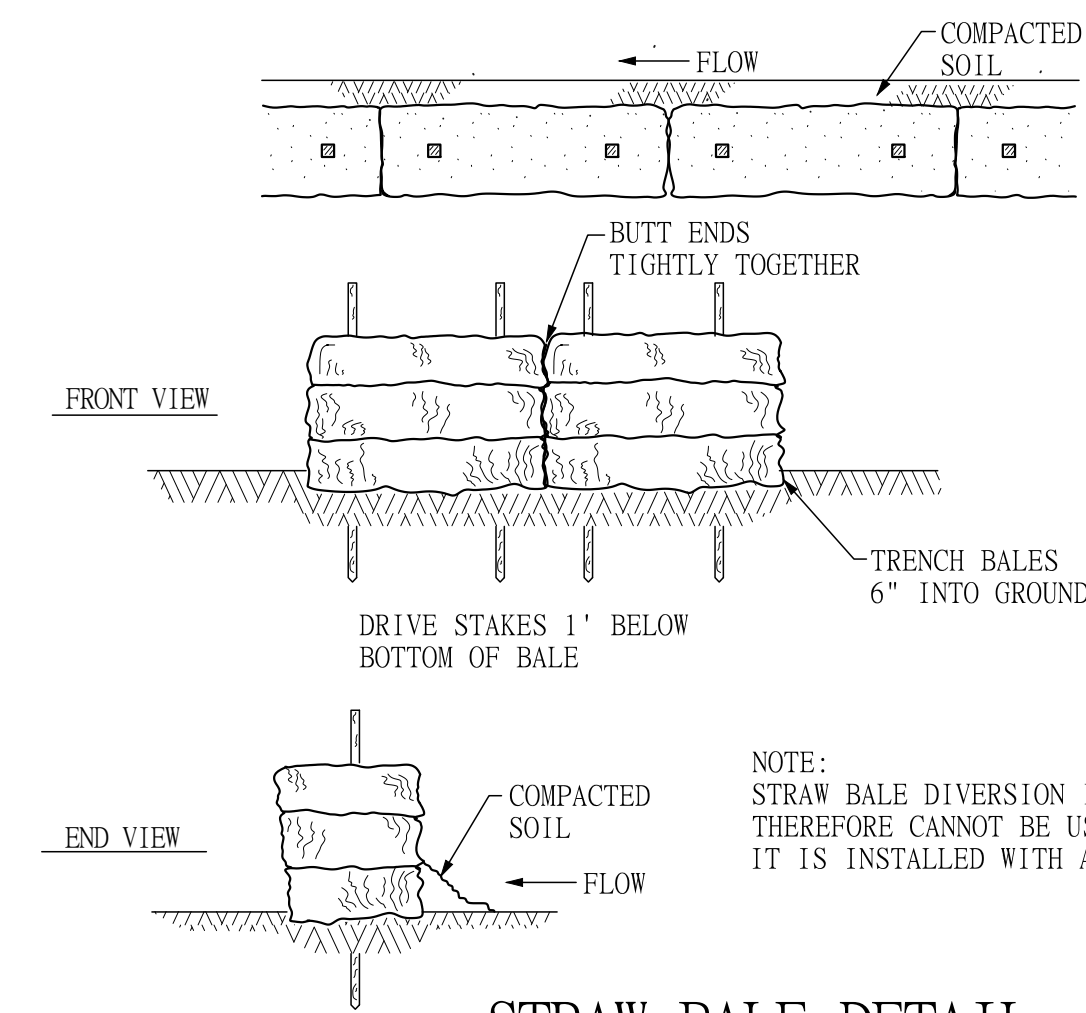

**STRAW BALE DETAIL**  
N.T.S.

NOTE:  
STRAW BALE DIVERSION IS NOT PERMEABLE AND THEREFORE CANNOT BE USED AS A FILTER UNLESS IT IS INSTALLED WITH A STONE OUTLET FILTER.

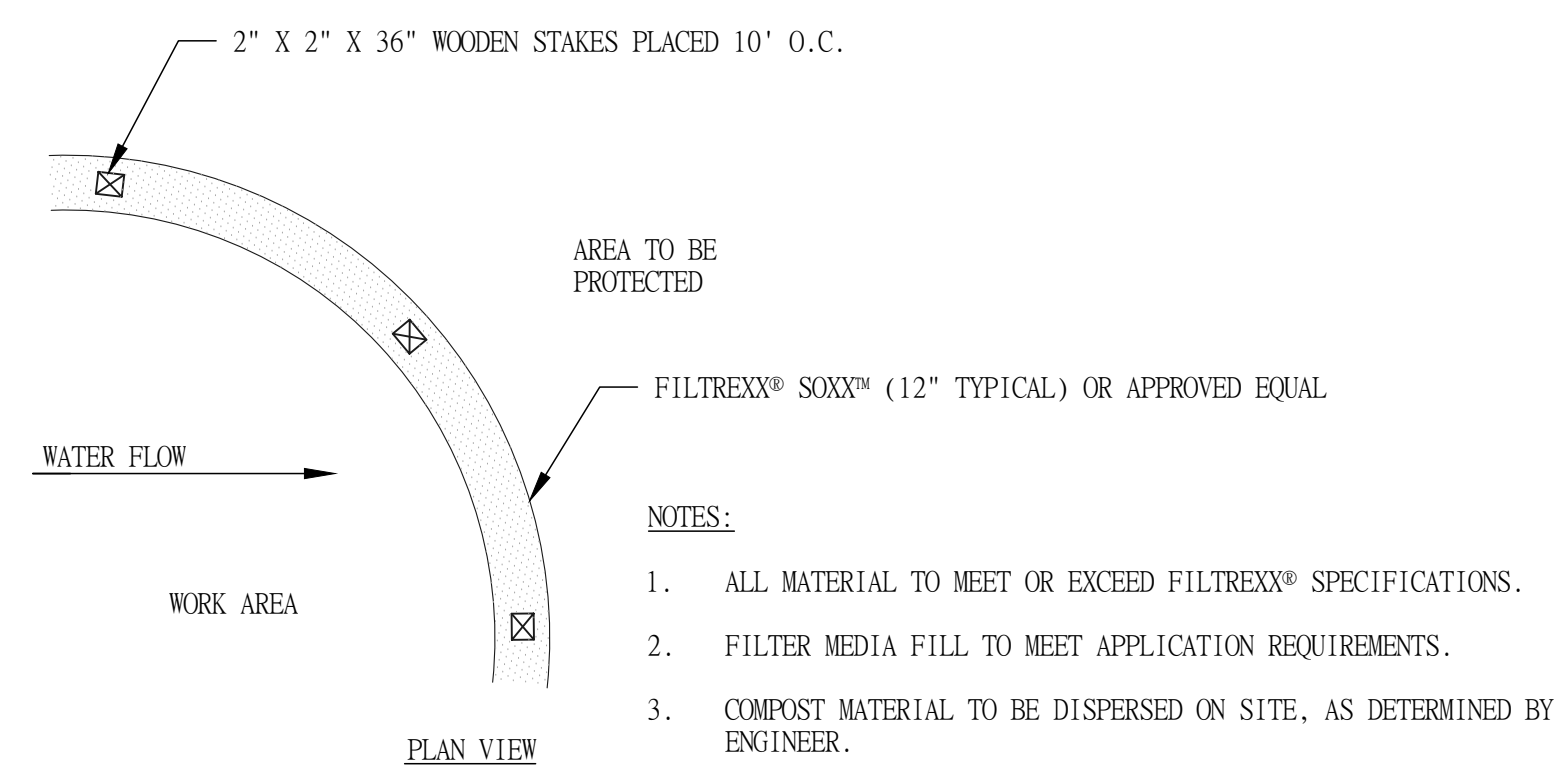

NOTES:

1. ALL MATERIAL TO MEET OR EXCEED FILTREXX® SPECIFICATIONS.
2. FILTER MEDIA FILL TO MEET APPLICATION REQUIREMENTS.
3. COMPOST MATERIAL TO BE DISPERSED ON SITE, AS DETERMINED BY ENGINEER.

**SEDIMENT CONTROL**  
N.T.S.

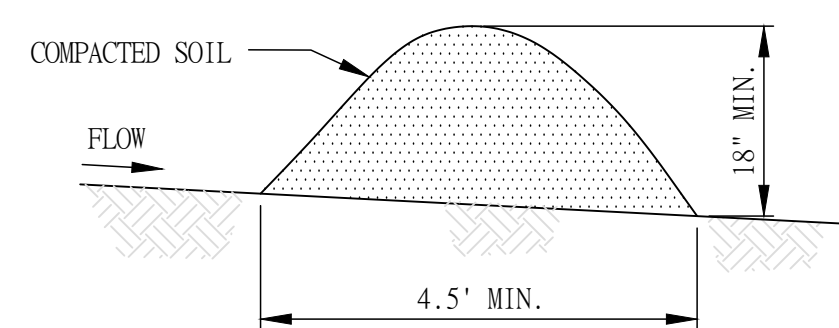

**TEMPORARY DIVERSION DIKE**  
N.T.S.

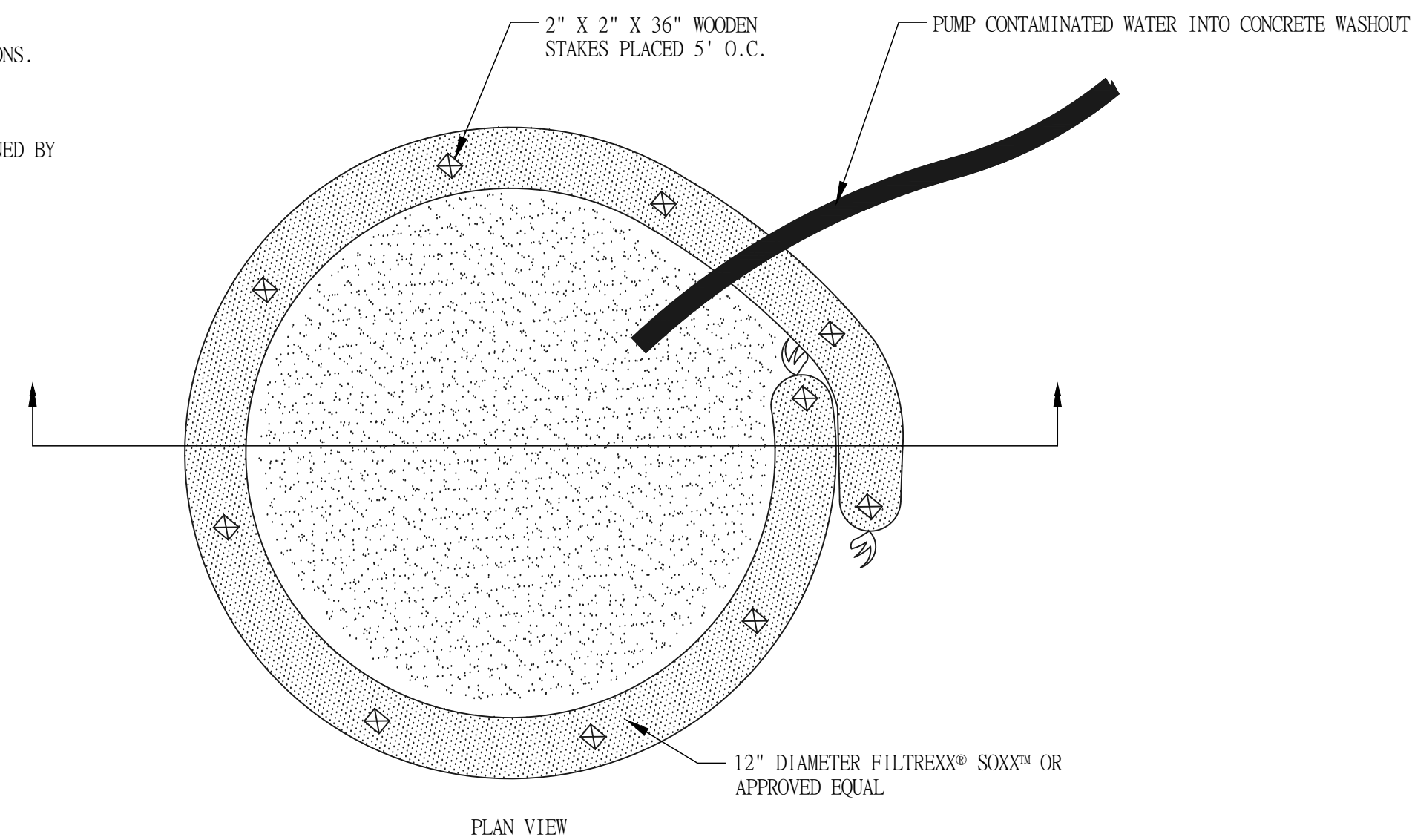

**CONCRETE WASHOUT STATION**

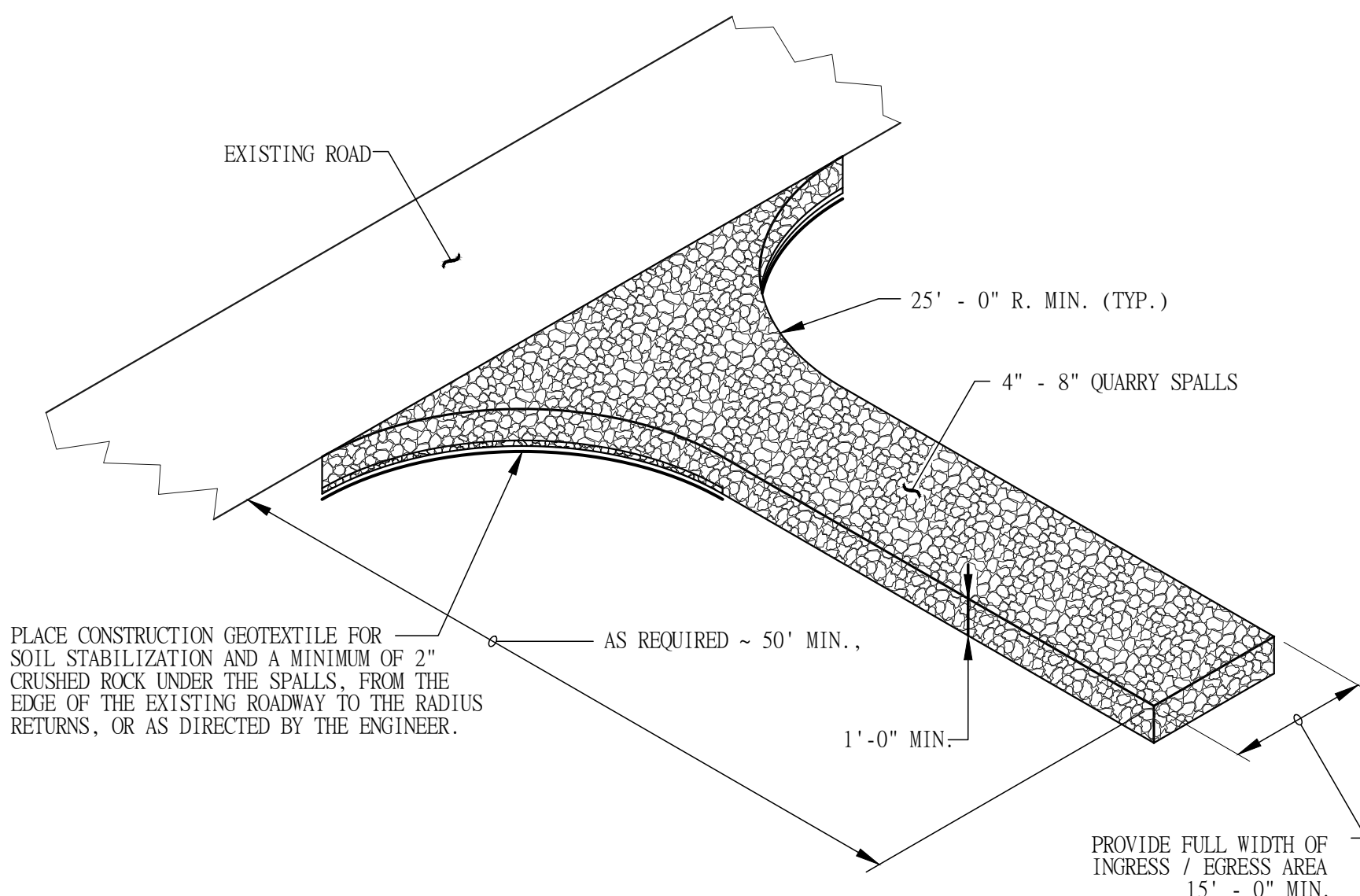

PLACE CONSTRUCTION GEOTEXTILE FOR SOIL STABILIZATION AND A MINIMUM OF 2" CRUSHED ROCK UNDER THE SPALLS, FROM THE EDGE OF THE EXISTING ROADWAY TO THE RADIUS RETURNS, OR AS DIRECTED BY THE ENGINEER.

**STABILIZED CONSTRUCTION ENTRANCE**  
N.T.S.

WWW.NESRAENG.COM  
607-506-3772

**NESRA ENGINEERING**

MASSACHUSETTS 02760  
829 SOUTH WASHINGTON STREET  
NORTH ATTLEBORO, MA 01940

ARSEN HAMBARDZUMIAN  
No. 9734  
REGISTERED PROFESSIONAL ENGINEER

PROJECT

LA SALLE ACADEMY JOHN P. CRONIN FIELD RENOVATION PROJECT, 612 ACADEMY AVE, PROVIDENCE, RI 02908

CLIENT

LA SALLE ACADEMY  
612 ACADEMY AVE  
PROVIDENCE, RI 02908

**BID SET**

NO.	REVISION	DATE

SCALE - AS NOTED  
DATE - 9/15/25

PROFESSIONAL SEAL

**CONSTRUCTION DETAILS I**

**C-10**

SINGLE LEAF GATES		
OPENING	GATE POSTS	HINGE SPACE (S)
FACE TO FACE	SQ & ROUND SIZES	POST TO UPRIGHT
3'-0" THROUGH 6'-0"	2 1/4" OR 3" O.D.	FOR SQUARE & ROUND
		GATE POSTS 2 1/4"

DOUBLE LEAF GATES		
OPENING	GATE POSTS	HINGE SPACE (S)
FACE TO FACE	SQ & ROUND SIZES	POST TO UPRIGHT
12'-0" THROUGH 24'-0"	3" OR 4" O.D.	FOR SQUARE & ROUND
		GATE POSTS 2 1/4"

SINGLE OR DOUBLE LEAF GATES		
NOMINAL HEIGHT (H)	UPRIGHT HEIGHT (U)	FRAME HEIGHT (F)
WITHOUT BARBED WIRE	ACTUAL DIMENSION	ACTUAL DIMENSION
4'-0"	3'-10"	3'-8 1/2"
6'-0"	5'-10"	5'-8 1/2"
8'-0"	7'-10"	7'-8 1/2"

FENCE HEIGHT	END & CORNER POSTS		LINE POSTS	
	NOMINAL HEIGHT	BAR LENGTH B-1	HEIGHT ABOVE GRADE H-1	BAR LENGTH B-2
4'-0"	7'-0"	4'-0 3/8"	6'-8"	3'-8 7/8"
6'-0"	9'-0"	6'-0 3/8"	8'-8"	5'-8 3/4"
8'-0"	11'-0"	8'-0 3/8"	10'-8"	7'-8 3/8"
12'-0"	15'-0"	12'-0 3/8"	14'-8"	11'-8 3/8"

**CHAIN LINK FENCE & GATE NOTES**  
N.T.S.

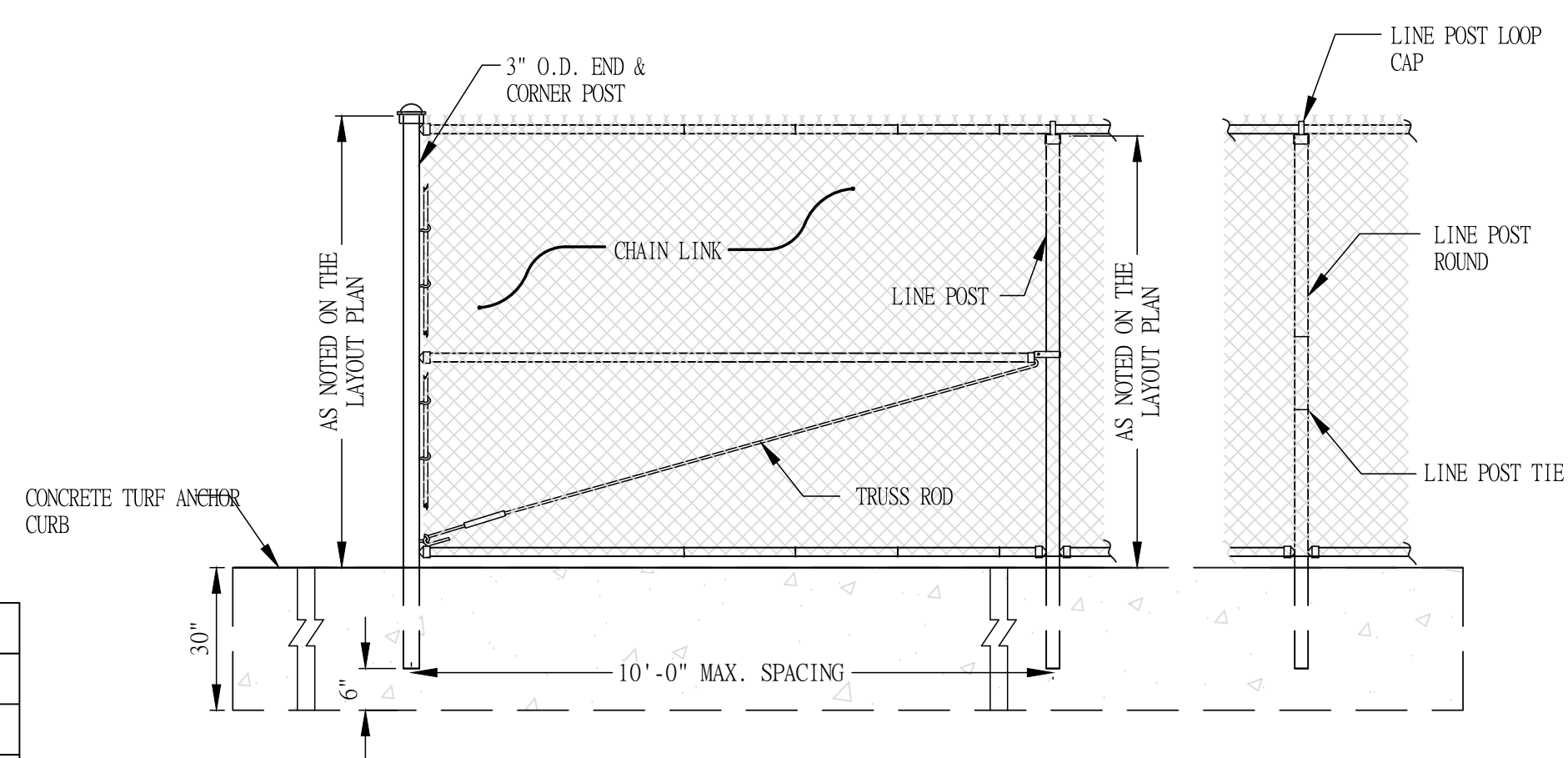

**CHAIN LINK FENCE DETAILS**  
N.T.S.

- NOTES:
- ALL CHAIN LINK FENCE FABRIC SHALL BE KNUCKLED (TOP AND BOTTOM)
  - ALL CHAIN LINK FENCE POSTS, FABRIC, TIES AND MATERIALS SHALL BE BLACK PVC COATED.
  - CENTER UPRIGHT REQUIRED ON GATE LEAVES 8'-0" AND WIDER. CENTER RAIL REQUIRED ON GATE LEAVES 6'-0" AND HIGHER
  - CONCRETE FOOTINGS SHALL BE FOUR TIMES THE POST DIAMETER, OR AS DESIGNATED ON INDIVIDUAL DETAILS.
  - FENCE CAP IN THE BASEBALL OUTFIELD SHALL BE PROVIDED AND MADE OF PRE-SLIT POLY TUBING 4 1/2" DIAMETER, COLOR TO BE YELLOW.
  - ALL GATE LATCHES TO BE HEAVY DUTY COMMERCIAL TYPE WITH LOCKING MECHANISM.

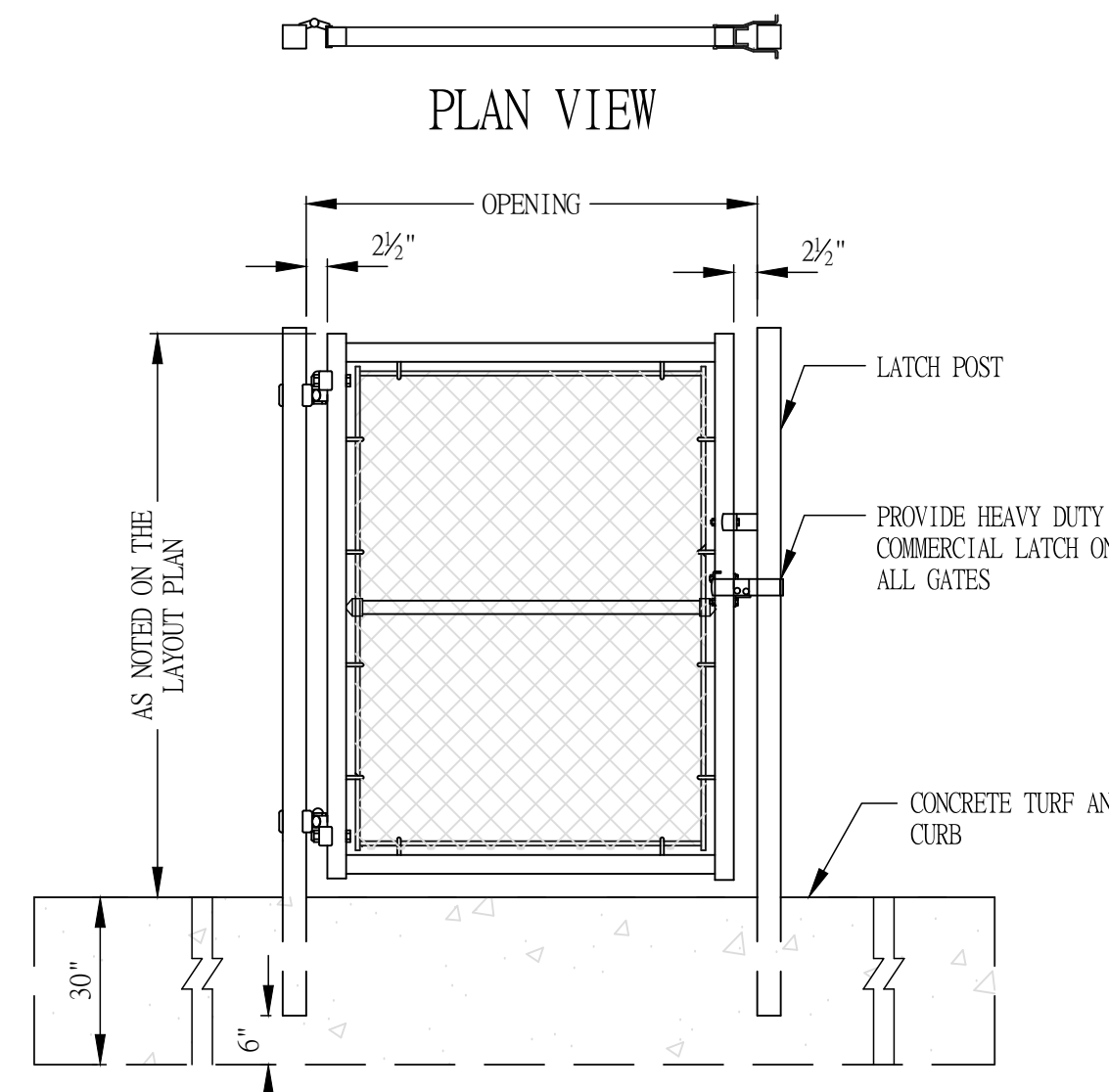

**SINGLE GATE DETAIL**  
N.T.S.

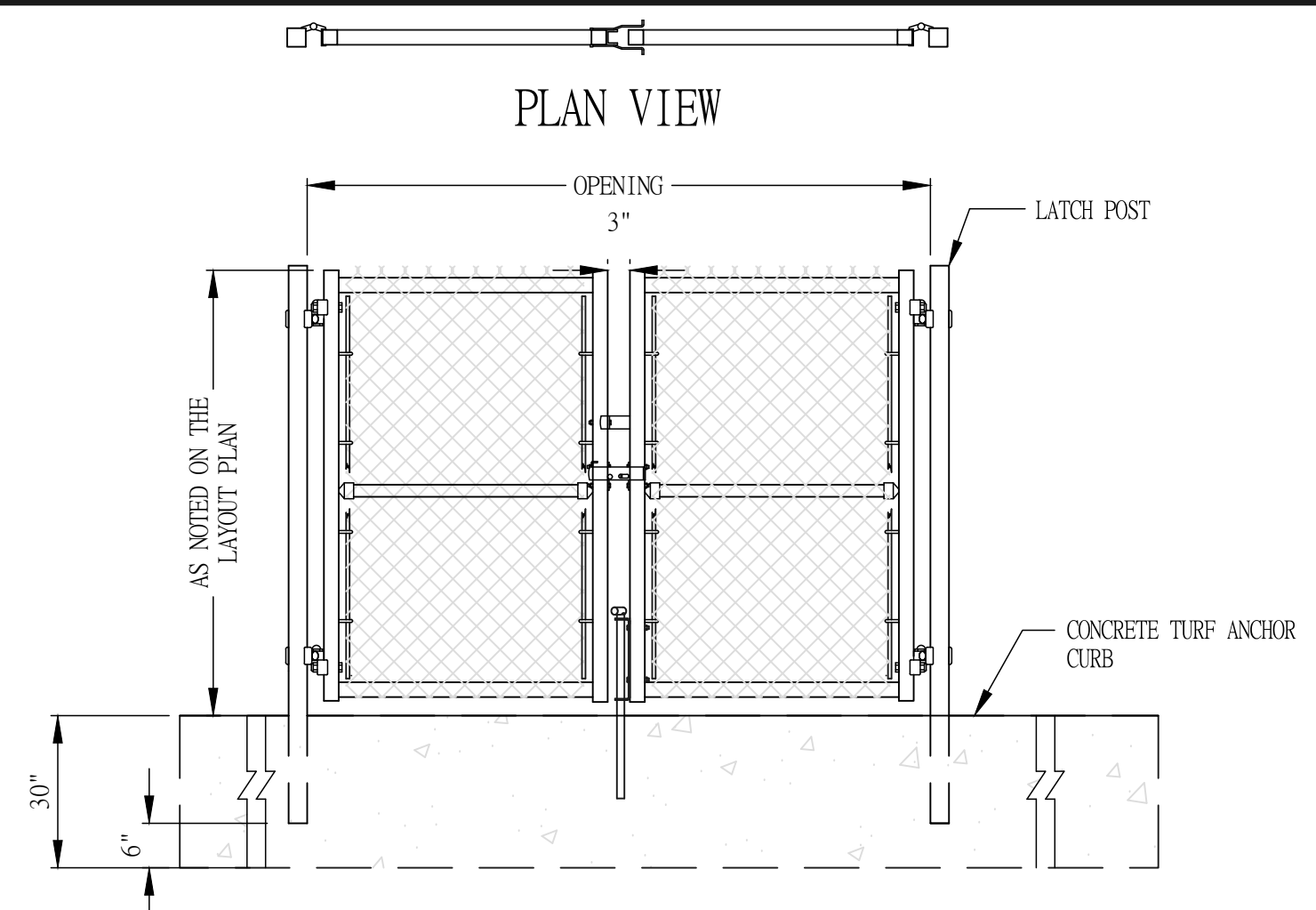

**DOUBLE GATE DETAIL**  
N.T.S.

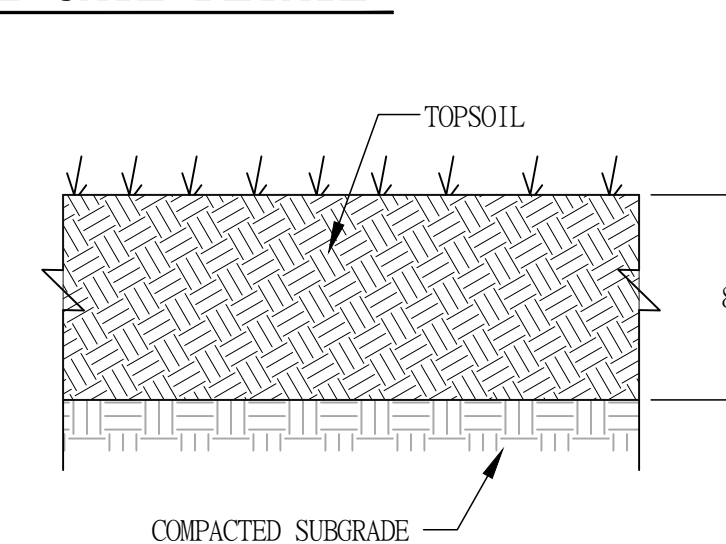

**LOAM AND SEED DETAIL**  
N.T.S.

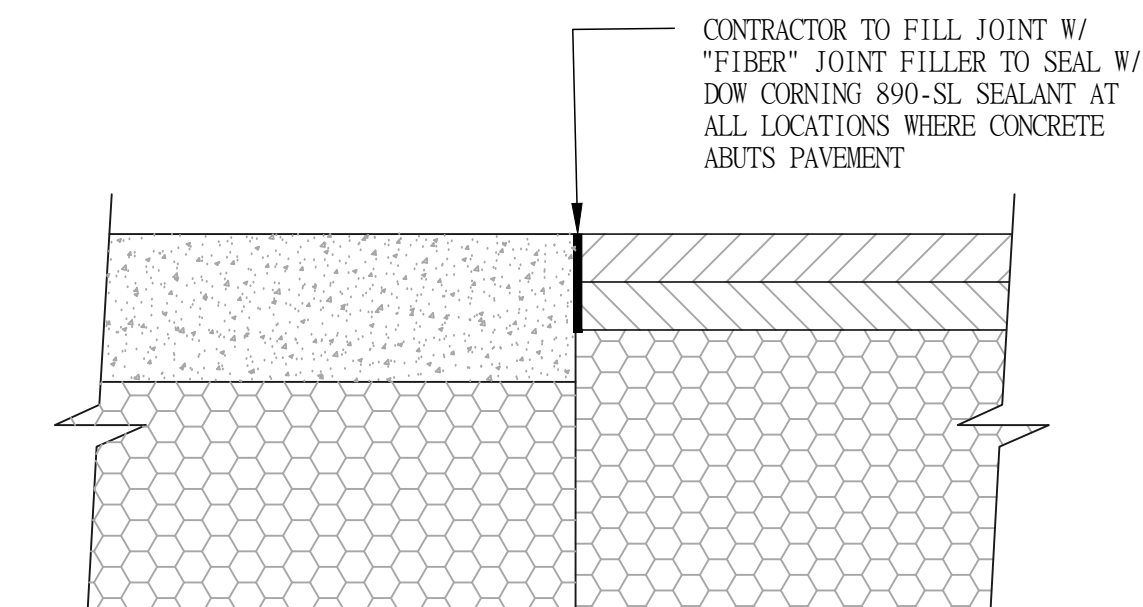

**CONCRETE TO PAVEMENT DETAIL**  
N.T.S.

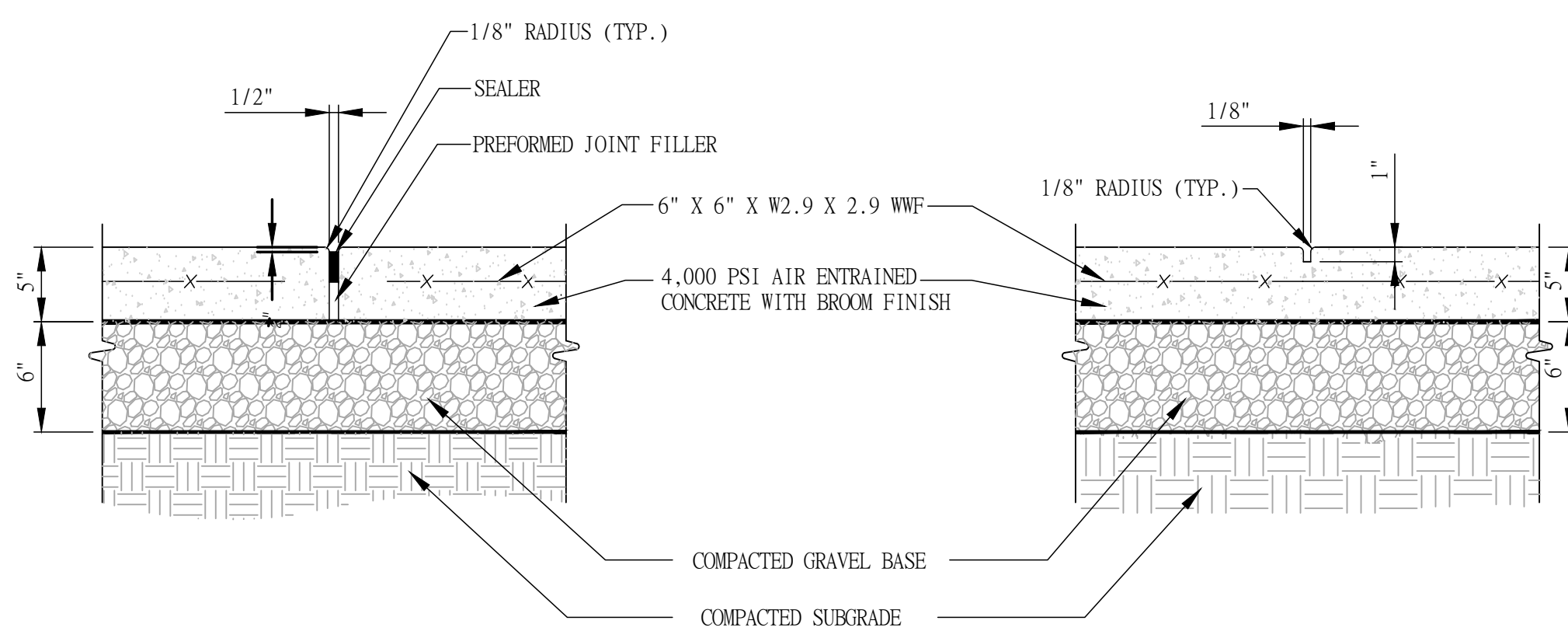

**EXPANSION JOINT**

**CONTROL JOINT**

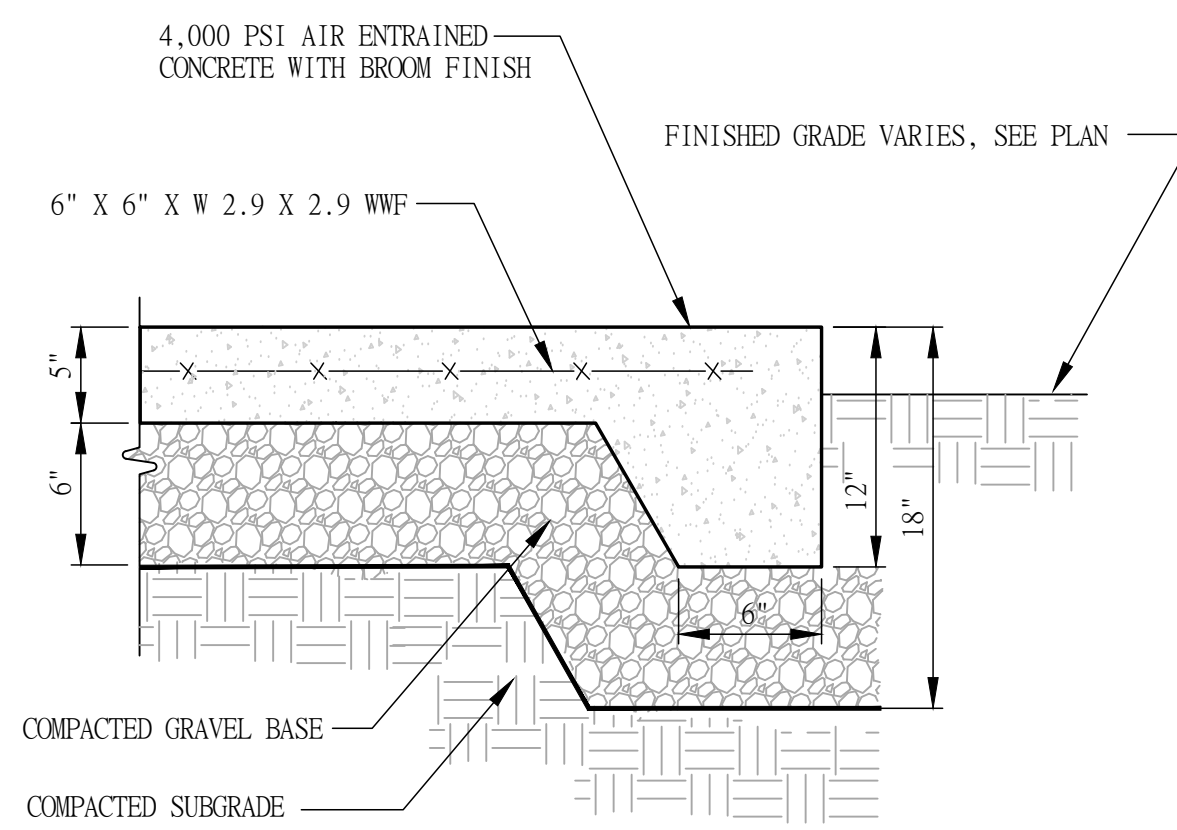

**END SECTION**

- NOTES:
- SEE SITE PLAN FOR WIDTH AND GRADES.
  - PROVIDE MINIMUM 1/4 IN. FT. CROSS SLOPE.
  - PROVIDE CONTROL JOINTS 5'-0" ON CENTER MINIMUM.
  - PROVIDE EXPANSION JOINTS 20'-0" ON CENTER MINIMUM.

**TYPICAL CONCRETE PAD DETAIL**  
N.T.S.

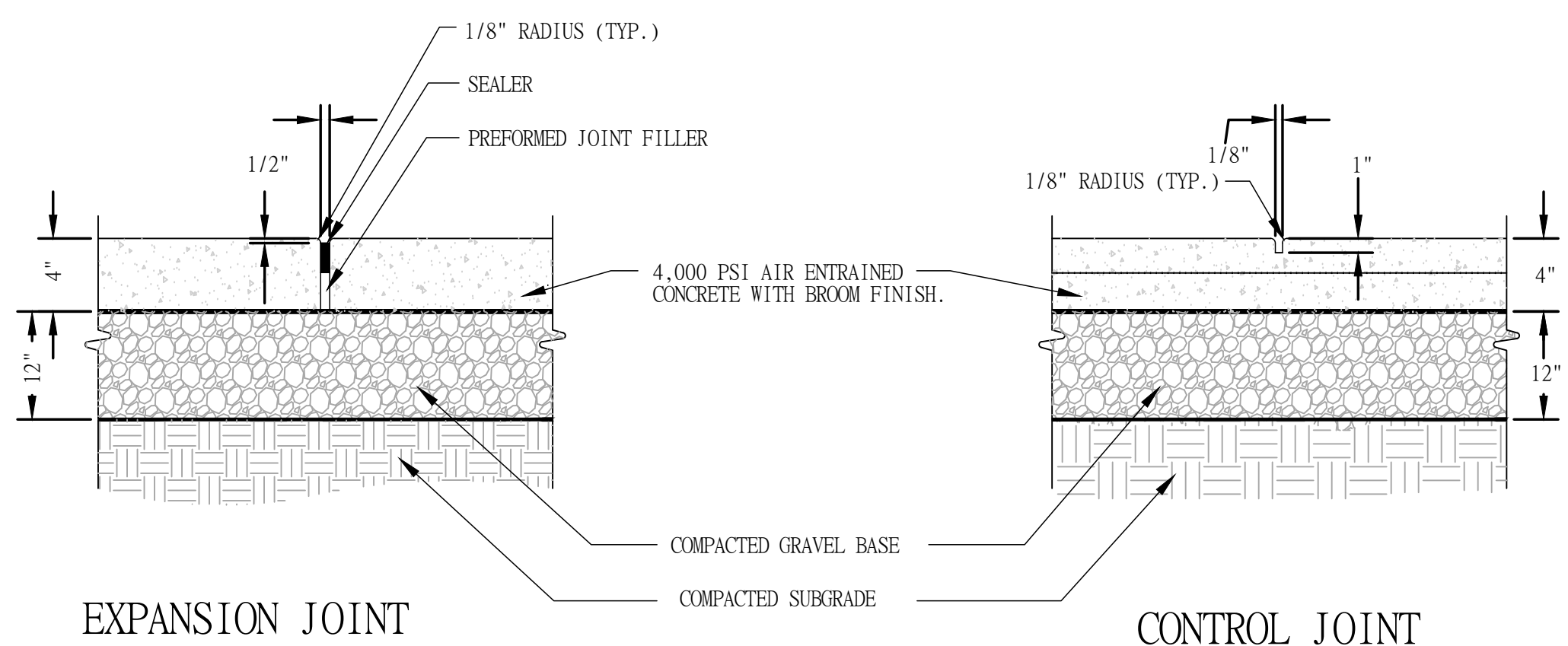

**EXPANSION JOINT**

**CONTROL JOINT**

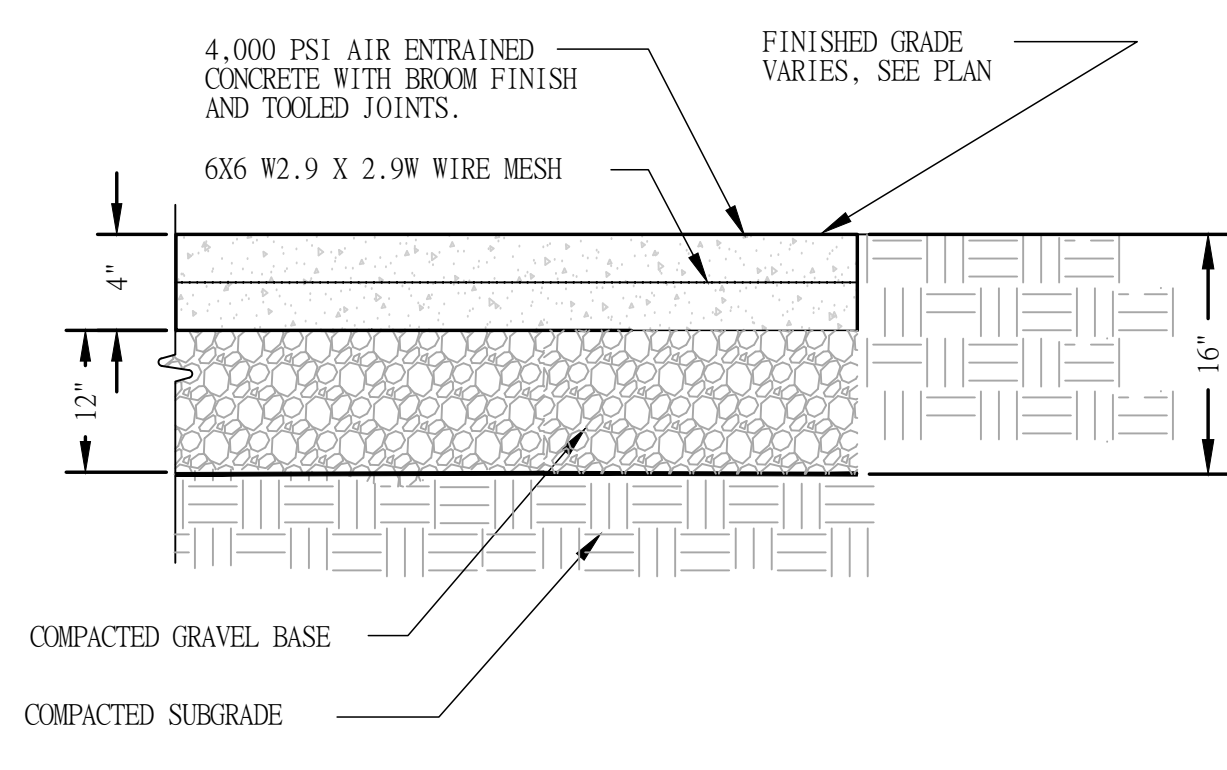

**END SECTION**

- NOTES:
- SEE SITE PLAN FOR WIDTH AND GRADES.
  - PROVIDE MINIMUM 1/4 IN. FT. CROSS-SLOPE.
  - PROVIDE CONTROL JOINTS 5'-0" ON CENTER MINIMUM.
  - PROVIDE EXPANSION JOINTS 20'-0" ON CENTER MINIMUM.

**TYPICAL CONCRETE WALKWAY DETAILS**  
N.T.S.

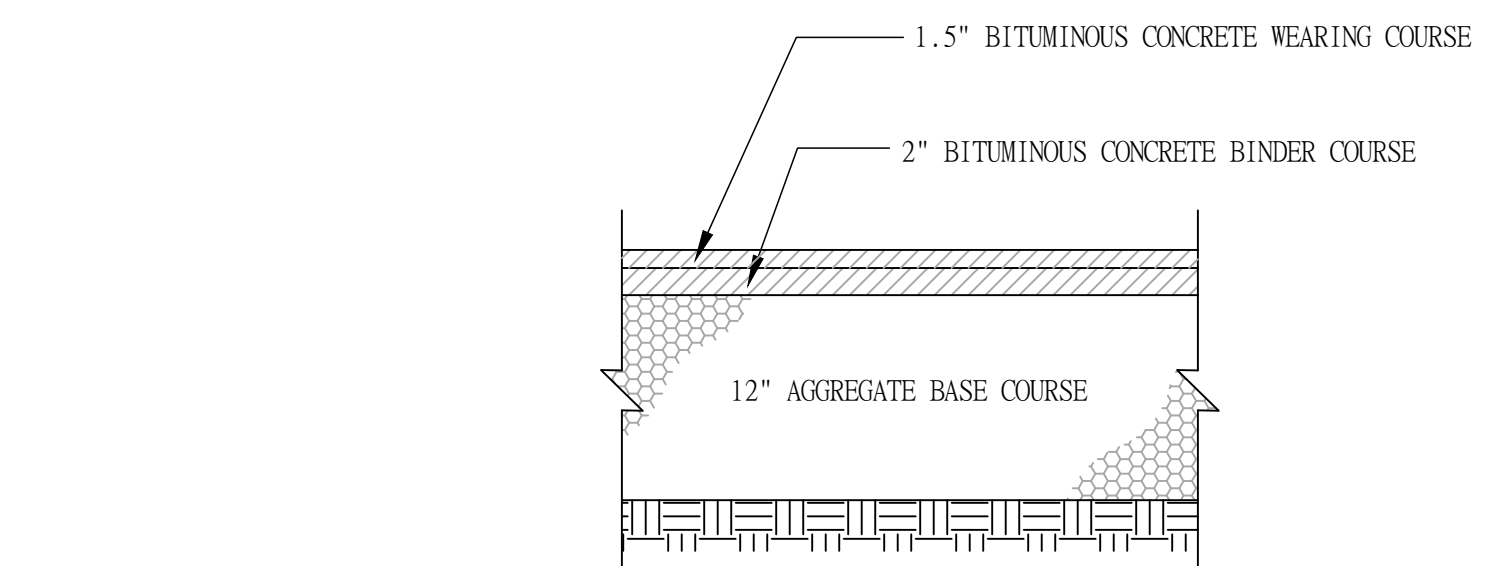

**BIT. CONC. PAVEMENT**  
N.T.S.

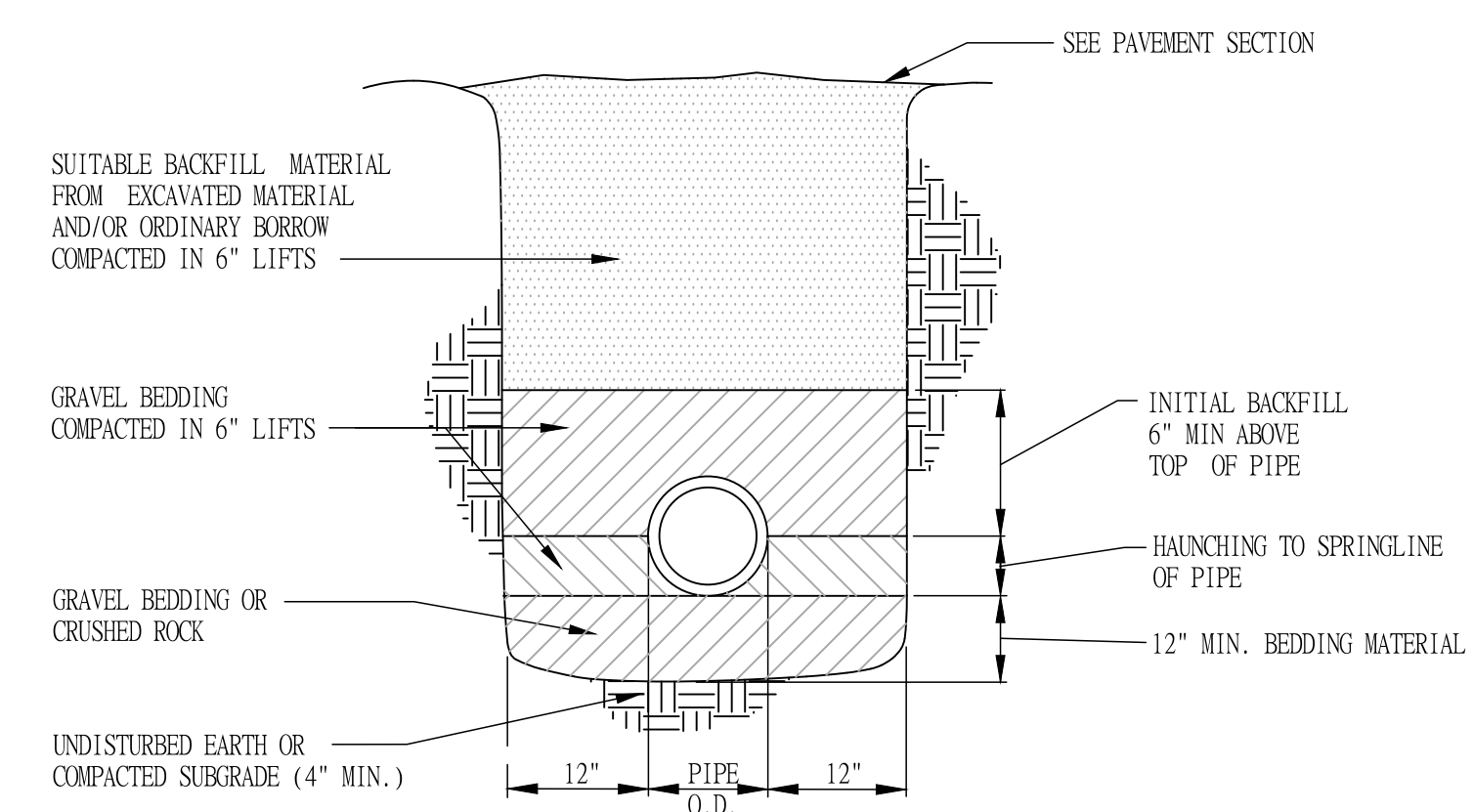

- NOTE:
- CONTRACTOR SHALL PROVIDE SHEETING, TRENCH BOX OR SLOPED WALLS IN ACCORDANCE WITH APPLICABLE SAFETY REGULATIONS.

**HDPE TRENCH DETAIL FOR SOLID PIPE (UP TO 24" DIA)**  
N.T.S.

WWW.NESRAENG.COM  
607-506-3772

**NESRA ENGINEERING**

MASSACHUSETTS 02760  
829 SOUTH WASHINGTON STREET  
NORTH ATTLEBORO, MA 01945

ARSEN HAMBARDZUMIAN  
No. 9734  
REGISTERED PROFESSIONAL ENGINEER

PROJECT  
LA SALLE ACADEMY JOHN P. CRONIN FIELD RENOVATION PROJECT, 612 ACADEMY AVE, PROVIDENCE, RI 02908

CLIENT  
LA SALLE ACADEMY  
612 ACADEMY AVE  
PROVIDENCE, RI 02908

**BID SET**

NO.	REVISION	DATE

SCALE - AS NOTED  
DATE - 9/15/25

PROFESSIONAL SEAL

**CONSTRUCTION DETAILS II**

**C-11**

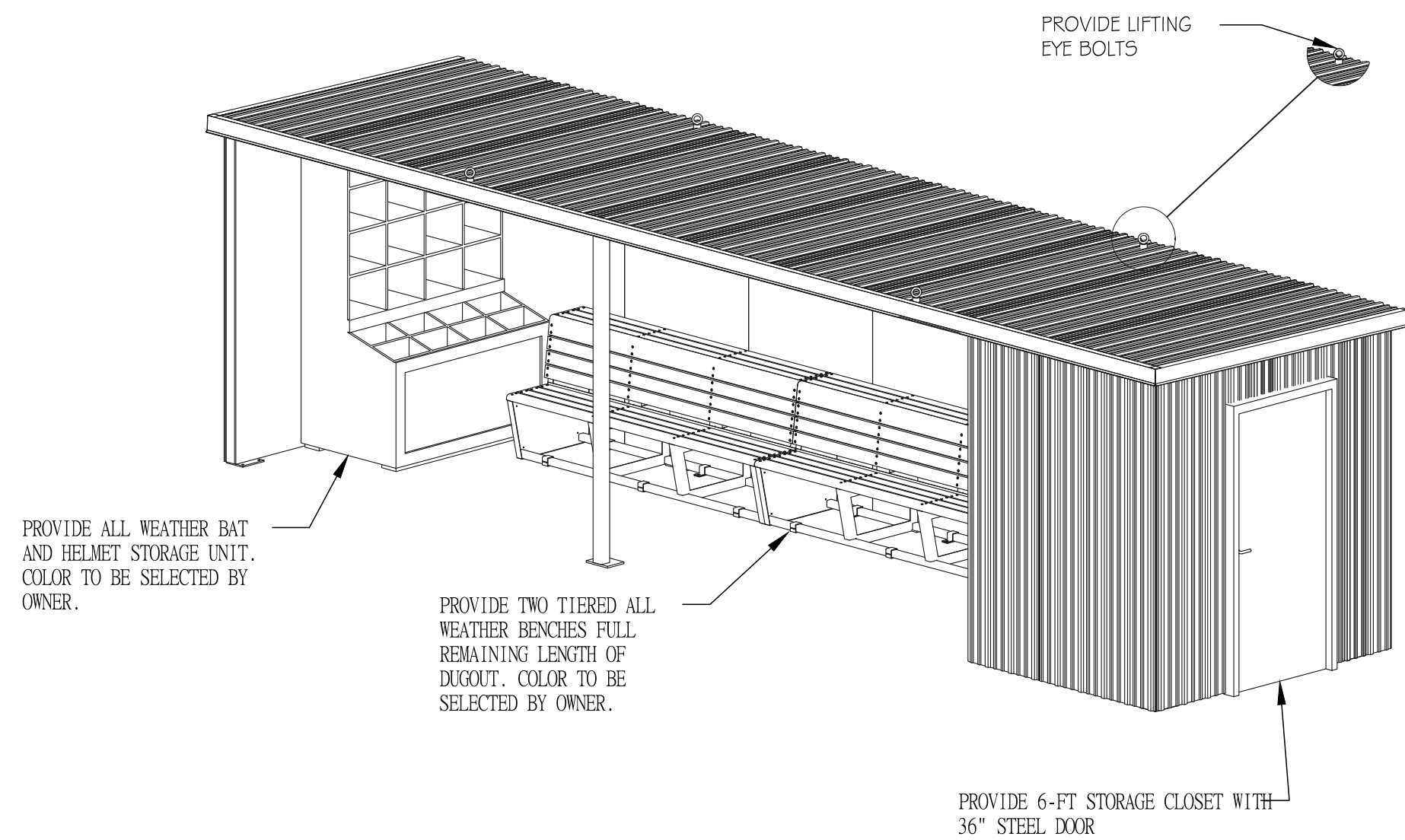
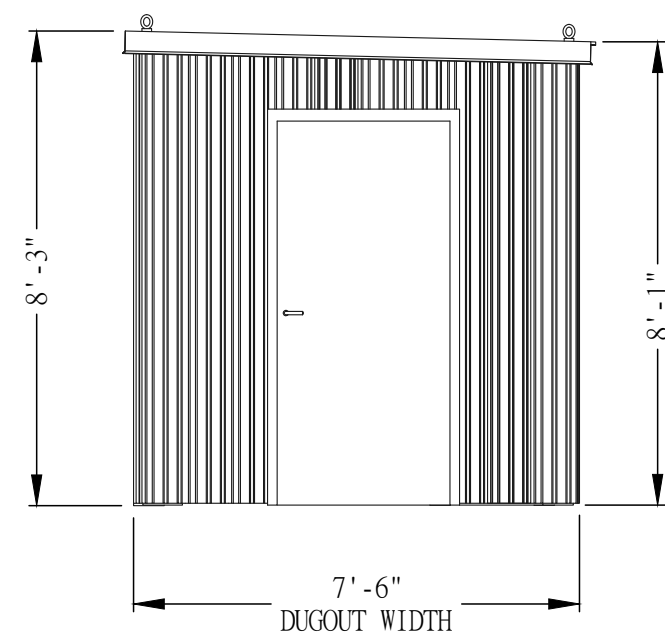

**NOTE:**

STEEL FRAME STRUCTURE SHALL BE POWDER COATED TUBULAR STEEL WITH GALVANIZED STEEL TRACK AND STUDS AT 16" O.C. OWNER TO SELECT FINISH TYPES AND COLOR FROM THE MANUFACTURER'S STANDARD COLOR AND FINISH PALLET AT NO ADDITIONAL CHARGE.

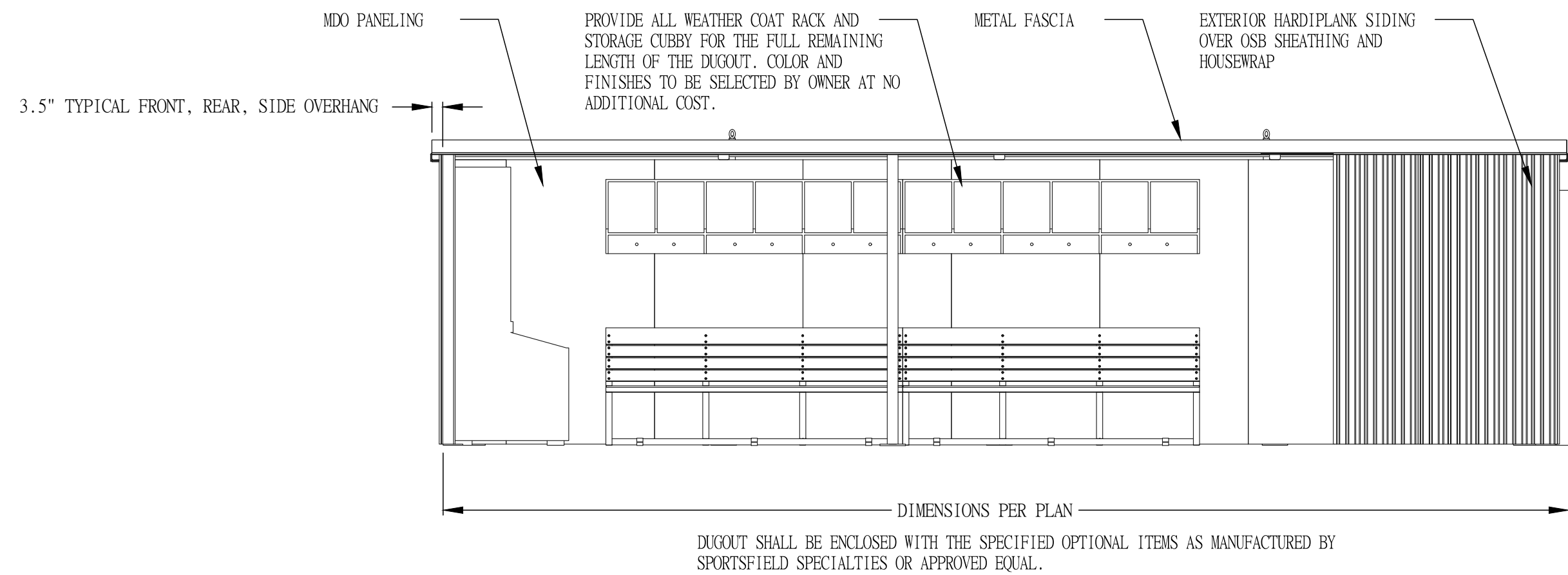

**ENCLOSED DUGOUT DETAIL**

N.T.S.

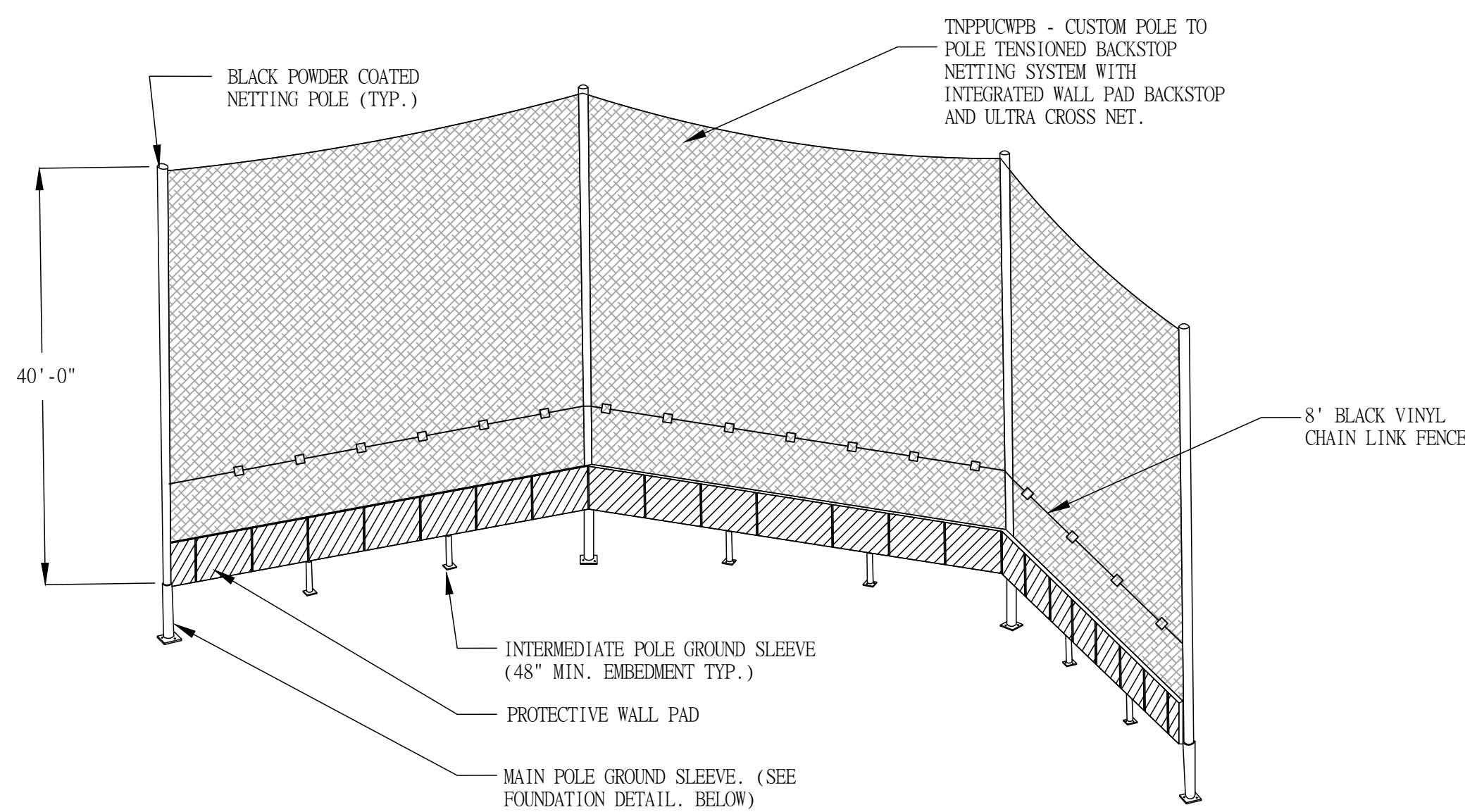

**NETTING SYSTEM**

N.T.S.

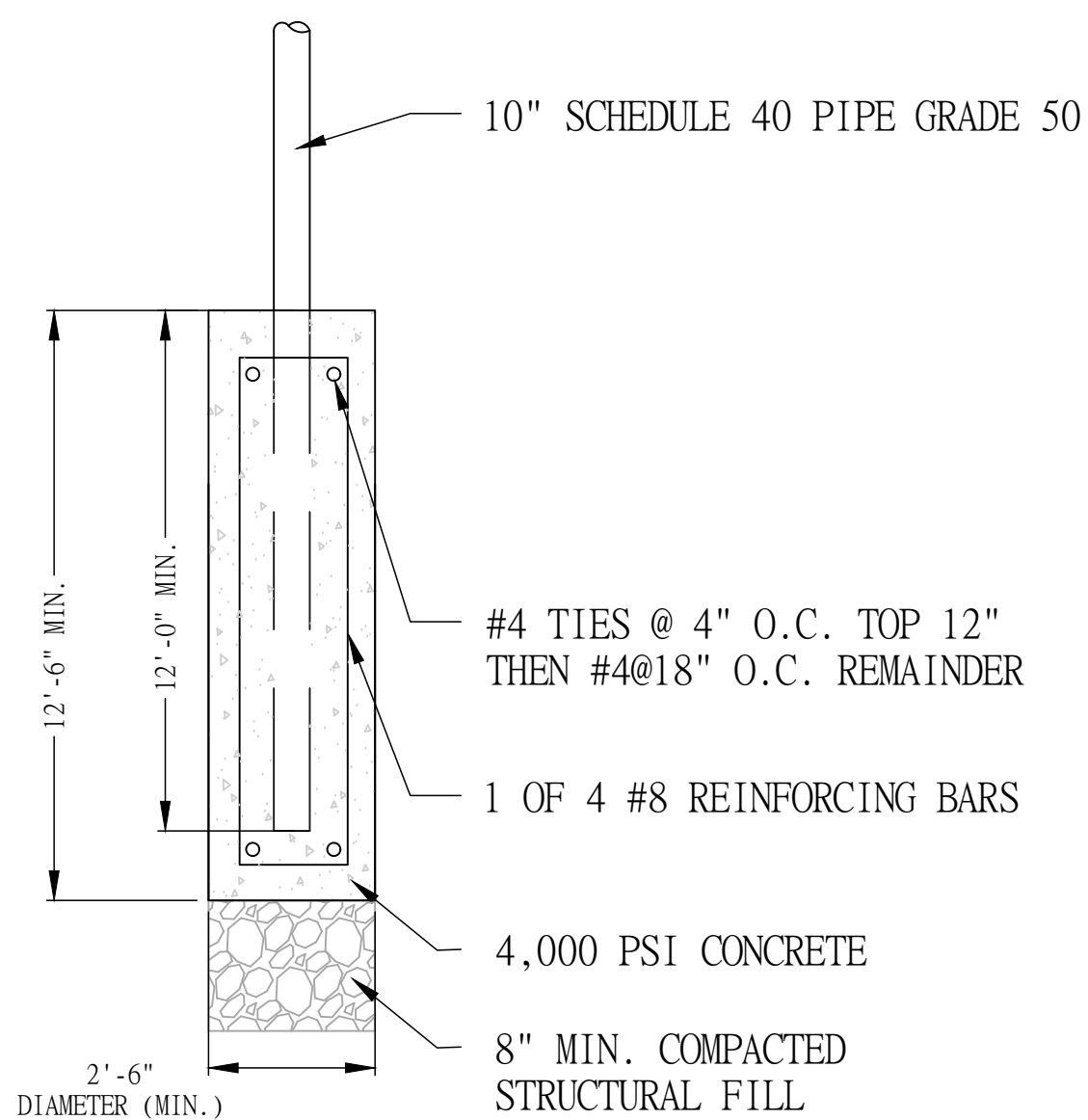

NOTE: FOUNDATION DESIGNED FOR PRICING PURPOSES. CONTRACTOR SHALL SUBMIT ENGINEERED STAMPED PLANS FOR MANUFACTURER FOR REVIEW AND APPROVAL.

**NETTING FOOTING DETAIL**

N.T.S.

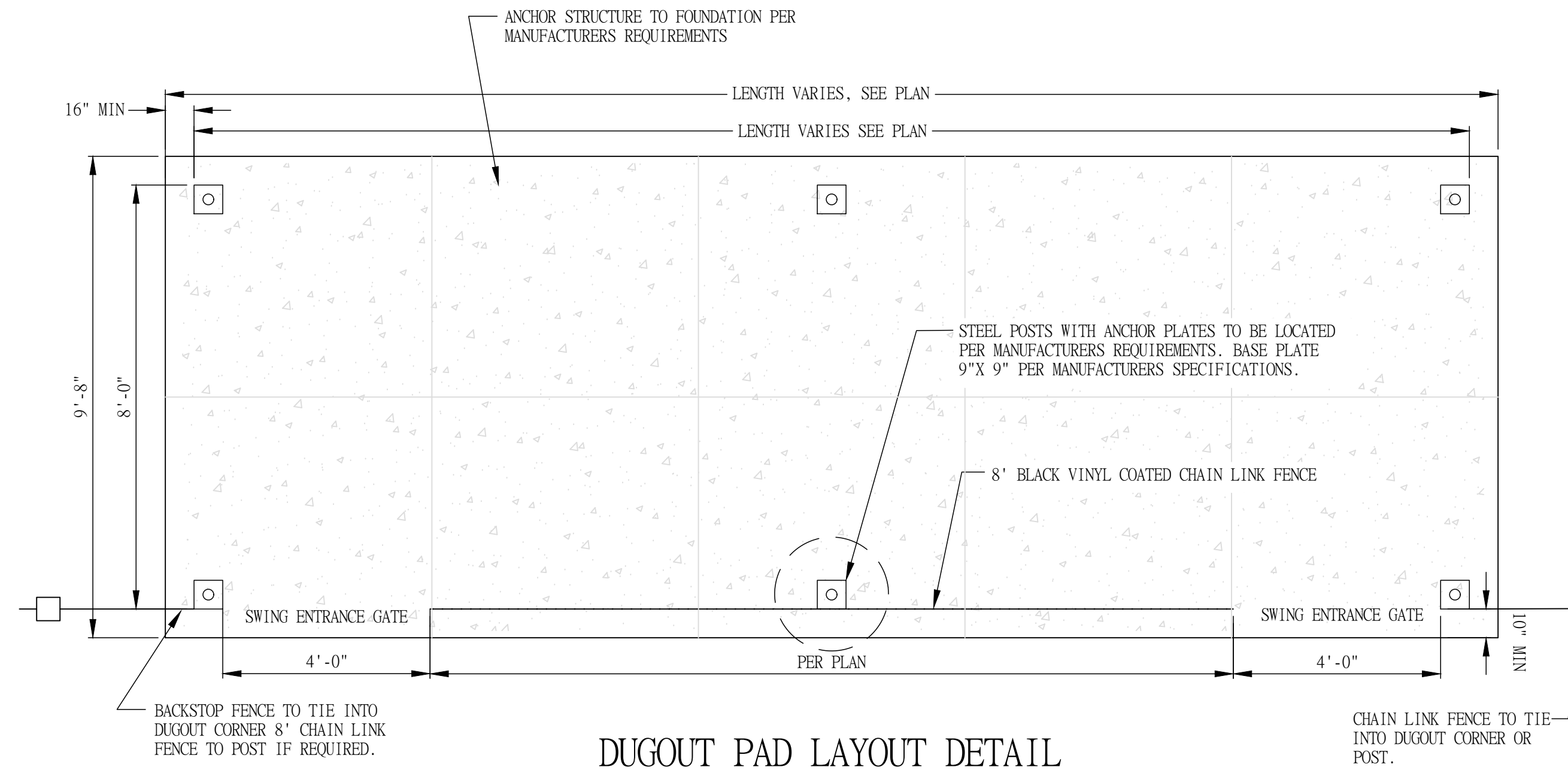

**DUGOUT PAD LAYOUT DETAIL**

N.T.S.

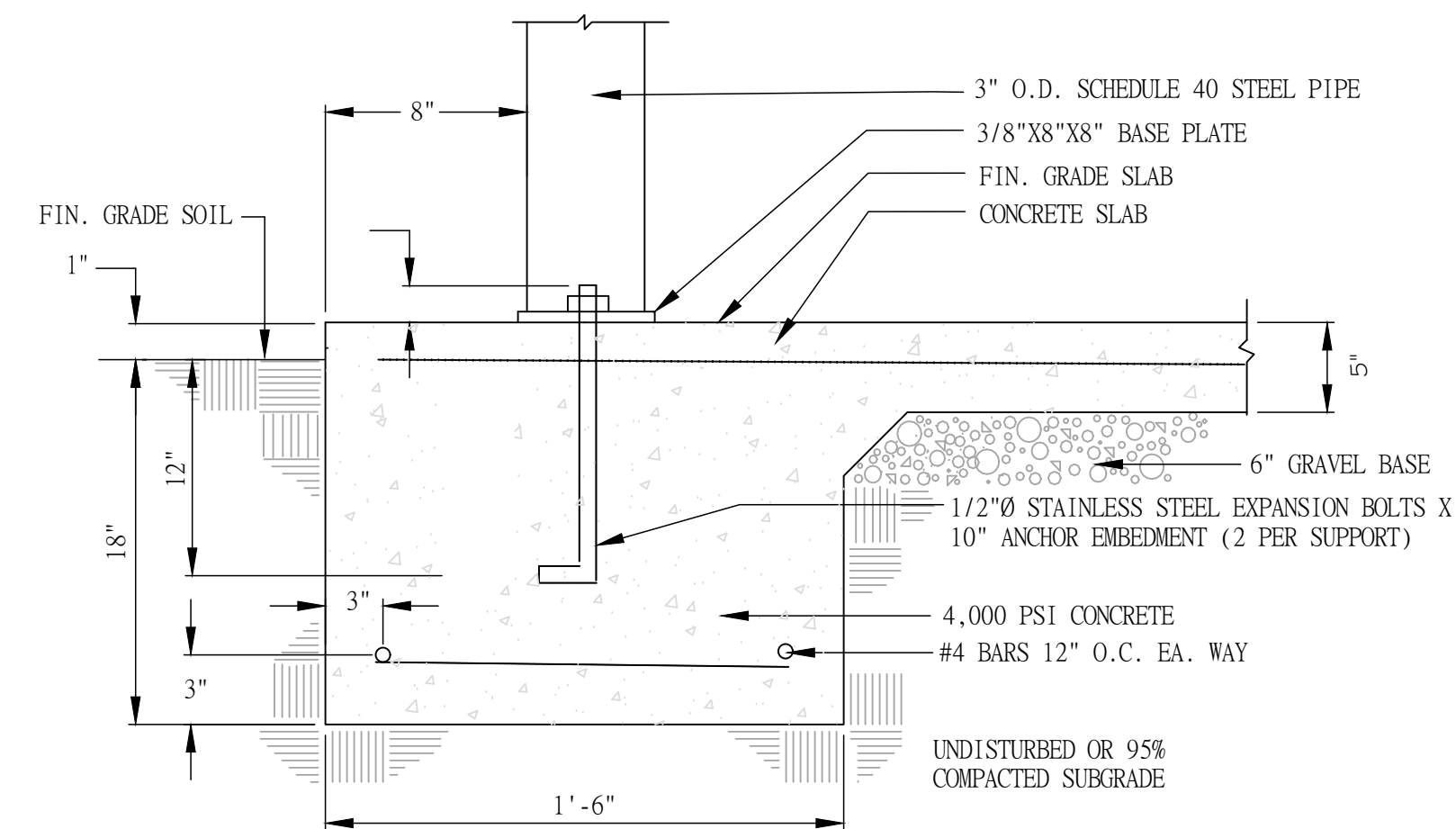

**BASEBALL DUGOUT ROOF ANCHORING DETAIL**

N.T.S.

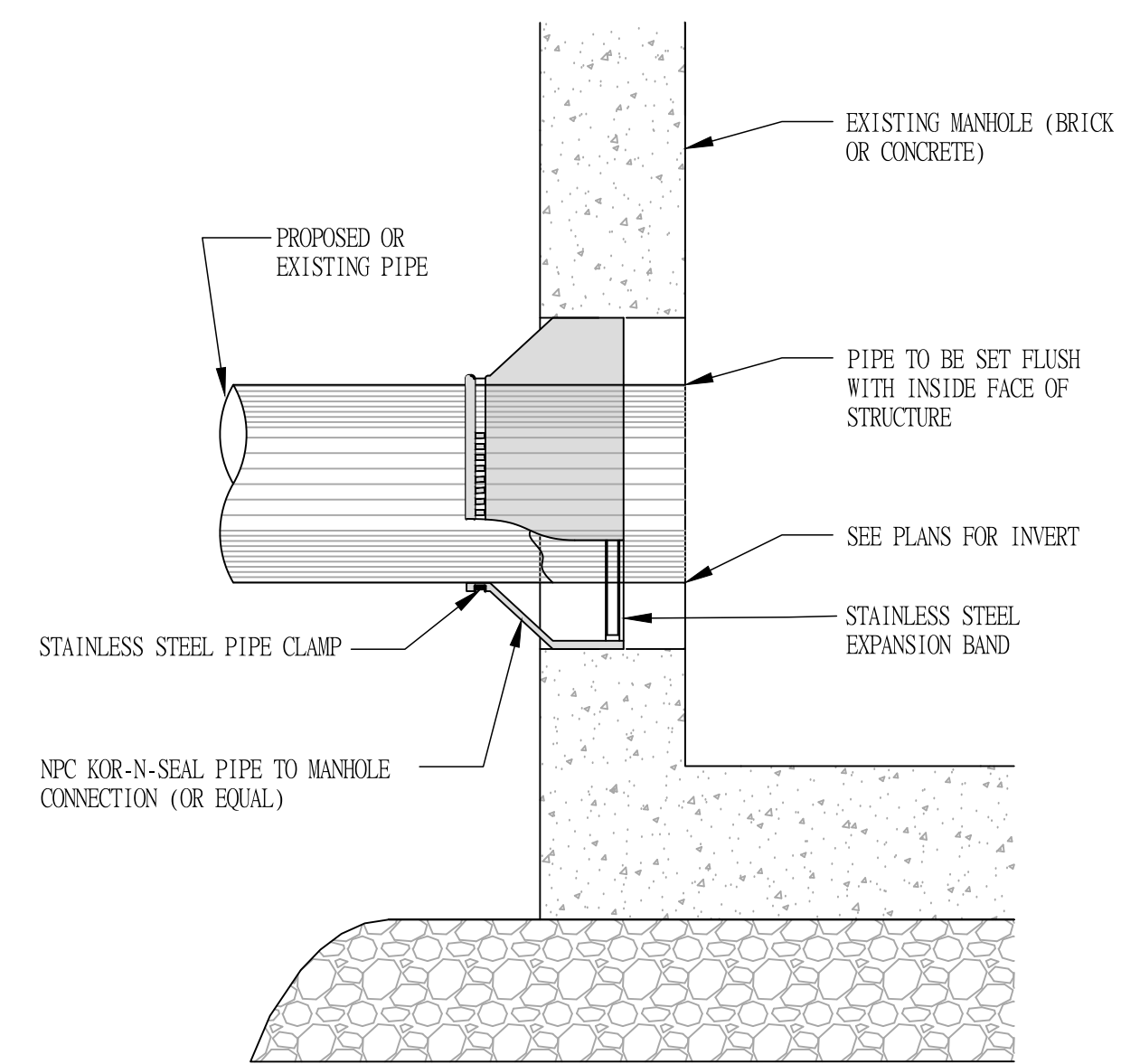

**NOTES:**

1. ALL METAL FIXTURES SHALL BE STAINLESS STEEL.
2. SERVICE LINE SHALL BE FLUSH WITH THE INSIDE OF THE MANHOLE.
3. FOR PROPOSED MANHOLE INSTALLATION AT EXISTING PIPE, CONTRACTOR SHALL EXTEND PIPE INTO NEW MANHOLE USING A SPOOL PIECE OF SAME PIPE MATERIAL WITH FERRO COUPLES.

**CONNECTION TO EXISTING MANHOLE**

N.T.S.

WWW.NESRAENG.COM  
607-506-3772

**NESRA ENGINEERING**

MA \* RI \* NH \* ME \* VT \* CT \* NY \* NJ \* PA \* OH \* WV \* VA \* NC \* SC \* GA \* FL \* AL \* MS \* LA \* TX \* OK \* MO \* IL \* IN \* MI \* WI \* MN \* IA \* MO \* NE \* KS \* CO \* WY \* MT \* ND \* SD \* NE \* KS \* CO \* WY \* MT \* ND \* SD

829 SOUTH WASHINGTON STREET  
NORTH ATTLEBORO  
MASSACHUSETTS 02760

ARSEN HAMBARDZUMIAN

No. 9734

REGISTERED PROFESSIONAL ENGINEER

**PROJECT**

LA SALLE ACADEMY JOHN P. CRONIN FIELD RENOVATION PROJECT, 612 ACADEMY AVE, PROVIDENCE, RI 02908

**CLIENT**

LA SALLE ACADEMY  
612 ACADEMY AVE  
PROVIDENCE, RI 02908

**BID SET**

NO.	REVISION	DATE

SCALE - AS NOTED  
DATE - 9/15/25

PROFESSIONAL SEAL

**CONSTRUCTION DETAILS III**

**C-12**

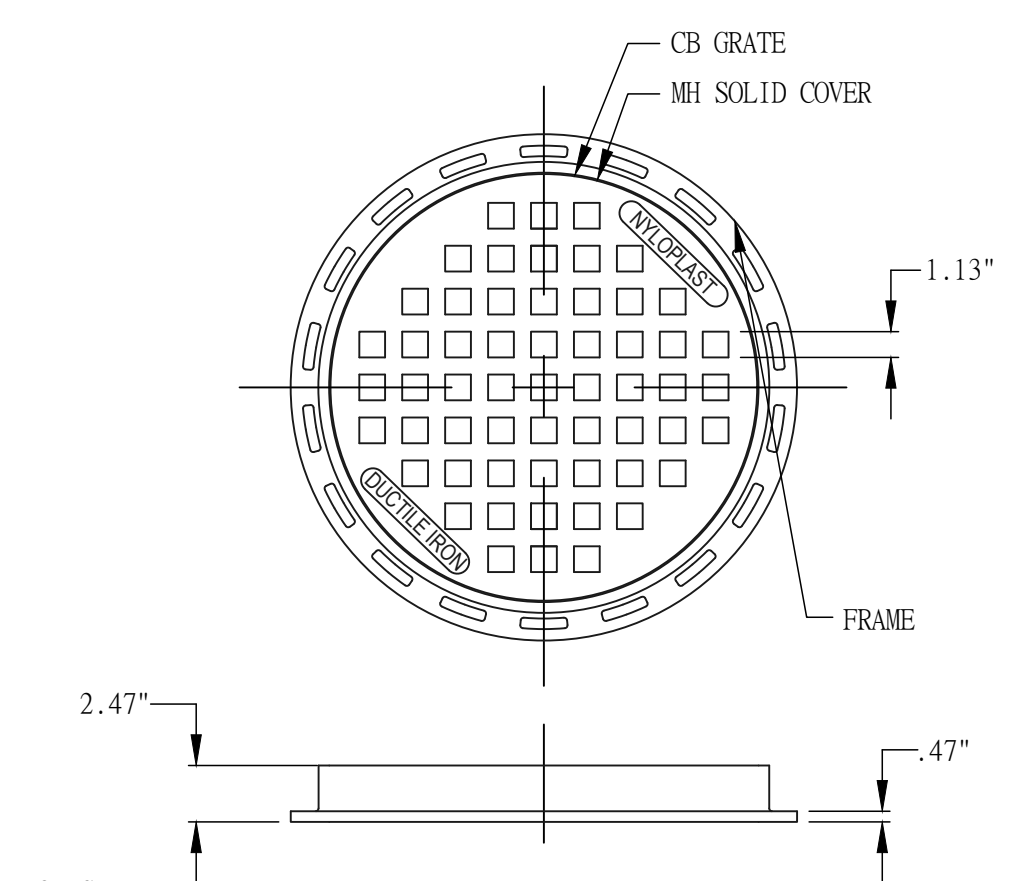

- NOTES:
- STANDARD MANHOLE SOLID COVER WITH H-25 HEAVY DUTY RATING
  - STANDARD CATCH BASIN GRATE WITH H-25 HEAVY DUTY RATING
  - MATERIALS SHALL CONFORM TO ASTM A-536 GRADE 70-50-05
  - MATERIAL SHALL BE DUCTILE IRON
  - CASTING SHALL BE FURNISHED WITH A BLACK LOCKING DEVICE. ZINC GOLD HEX BOLT 1" LONG IN TWO PLACES.

**NYLOPLAST MANHOLE/CATCH BASIN COVER**  
N.T.S.

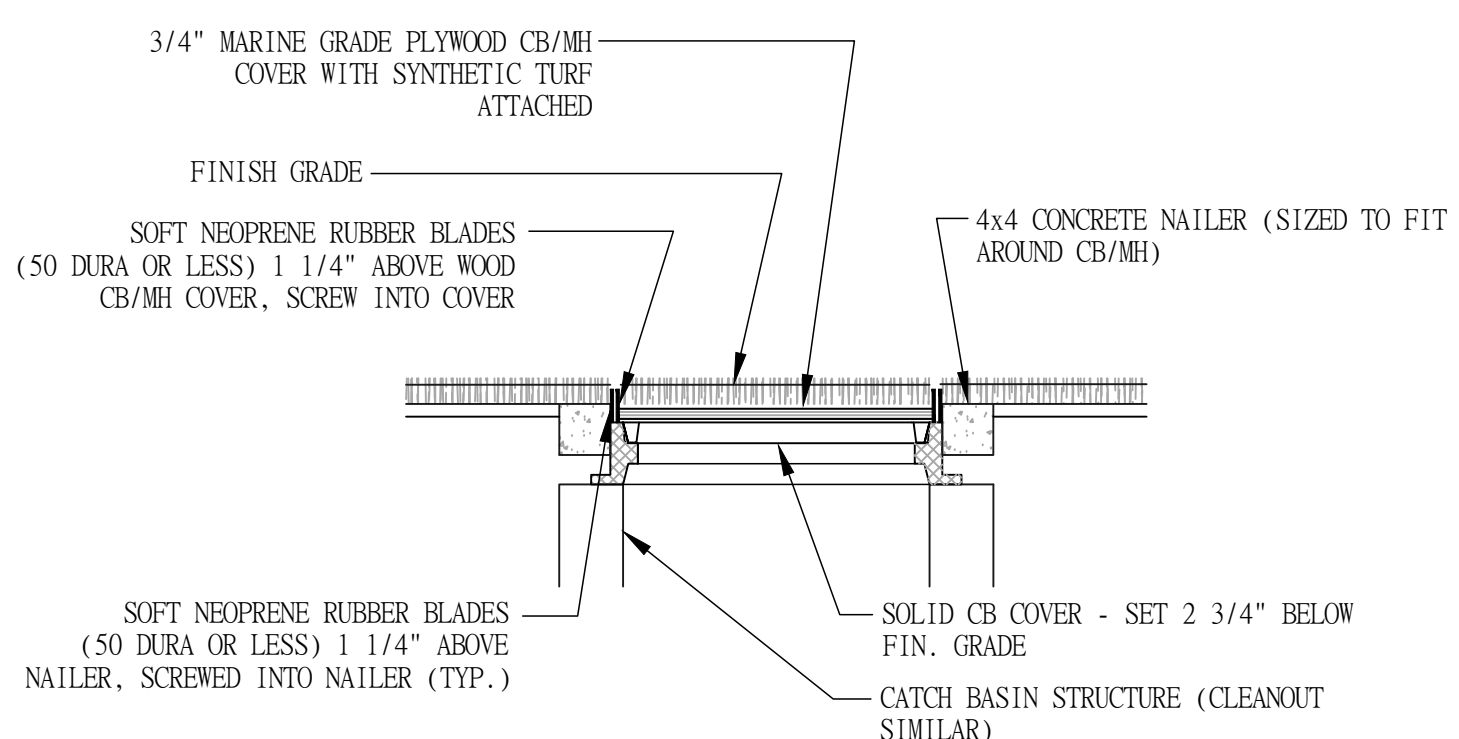

NOTE:  
CONTRACTOR TO MAKE SURE DRAINAGE STRUCTURES WITHIN LIMITS OF SYNTHETIC TURF ARE FULLY ACCESSIBLE POST CONSTRUCTION.

**MANHOLE COVER WITHIN SYNTHETIC TURF LIMITS**  
N.T.S.

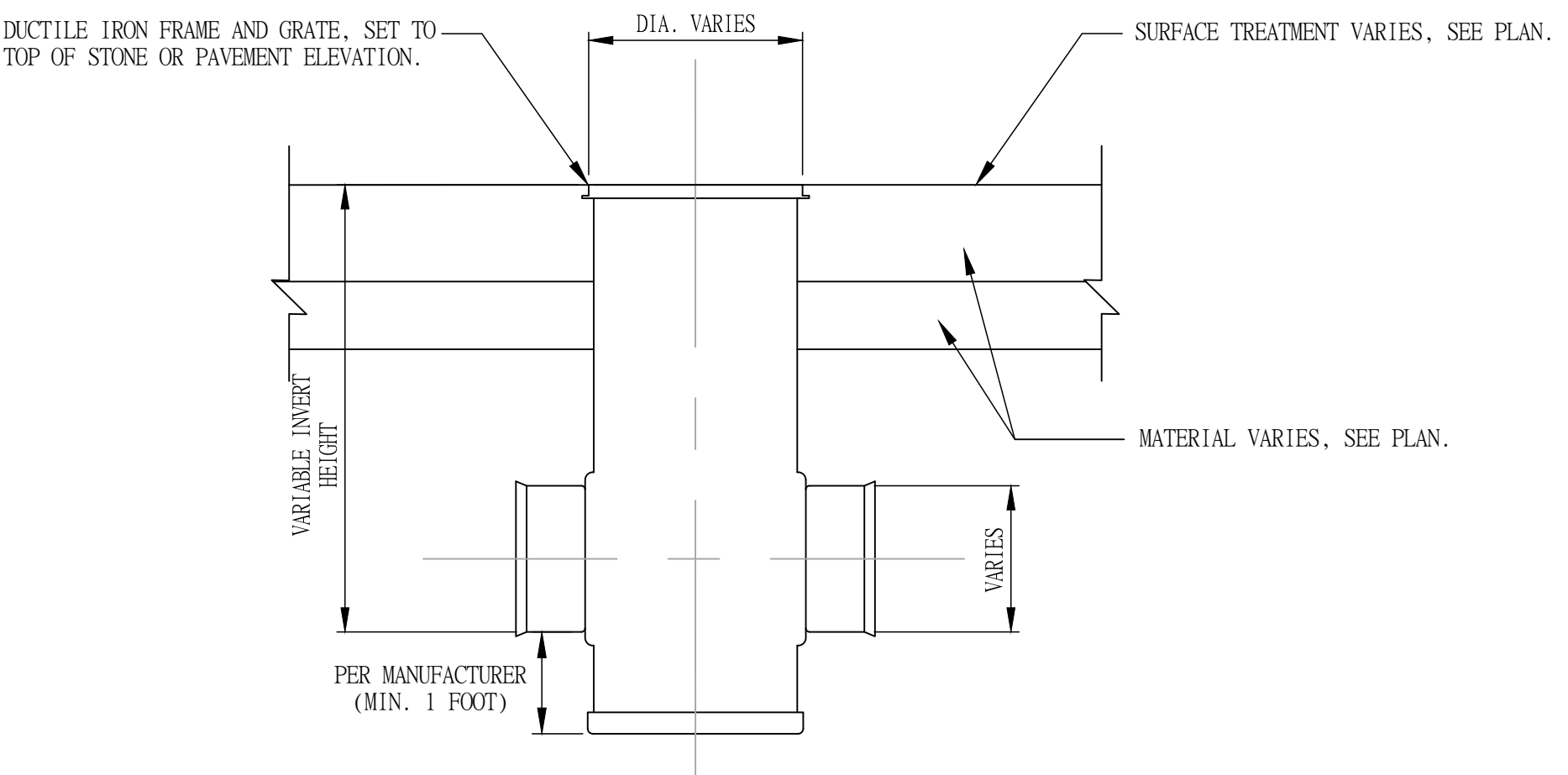

**NYLOPLAST MANHOLE OR CATCH BASIN**  
N.T.S.

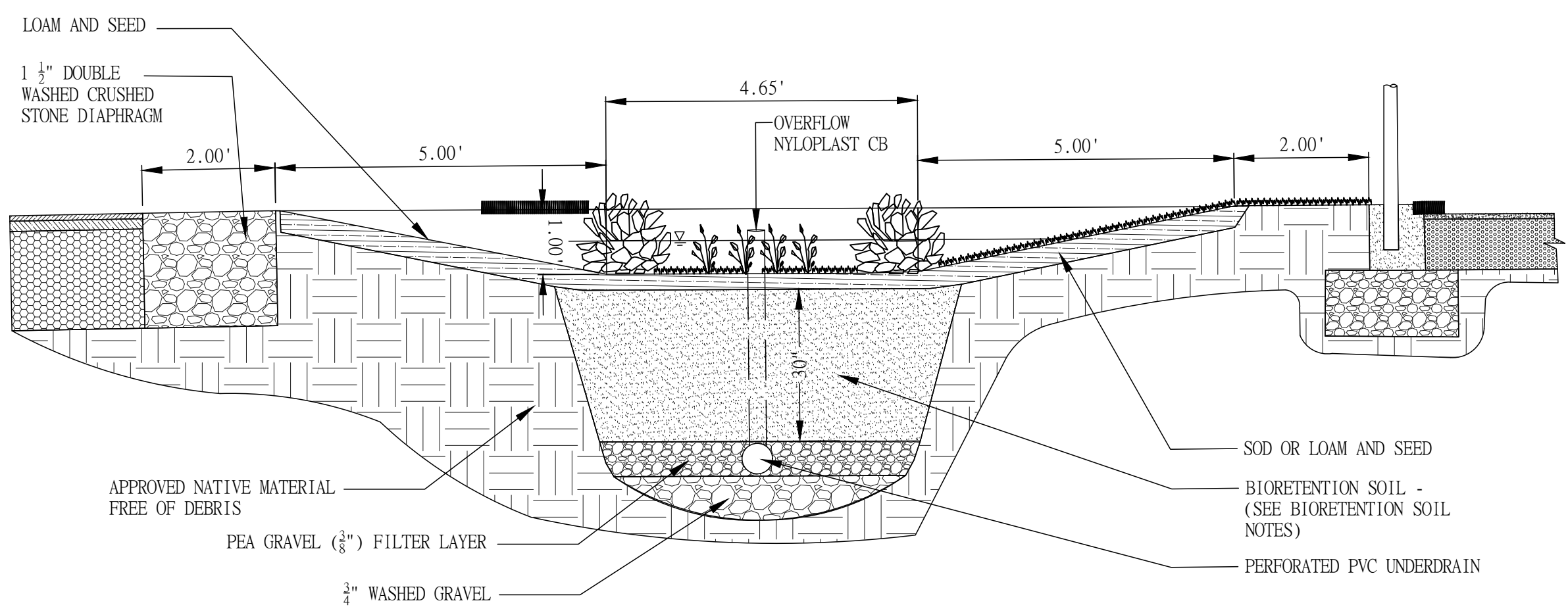

**BIORETENTION AREA**  
N.T.S.

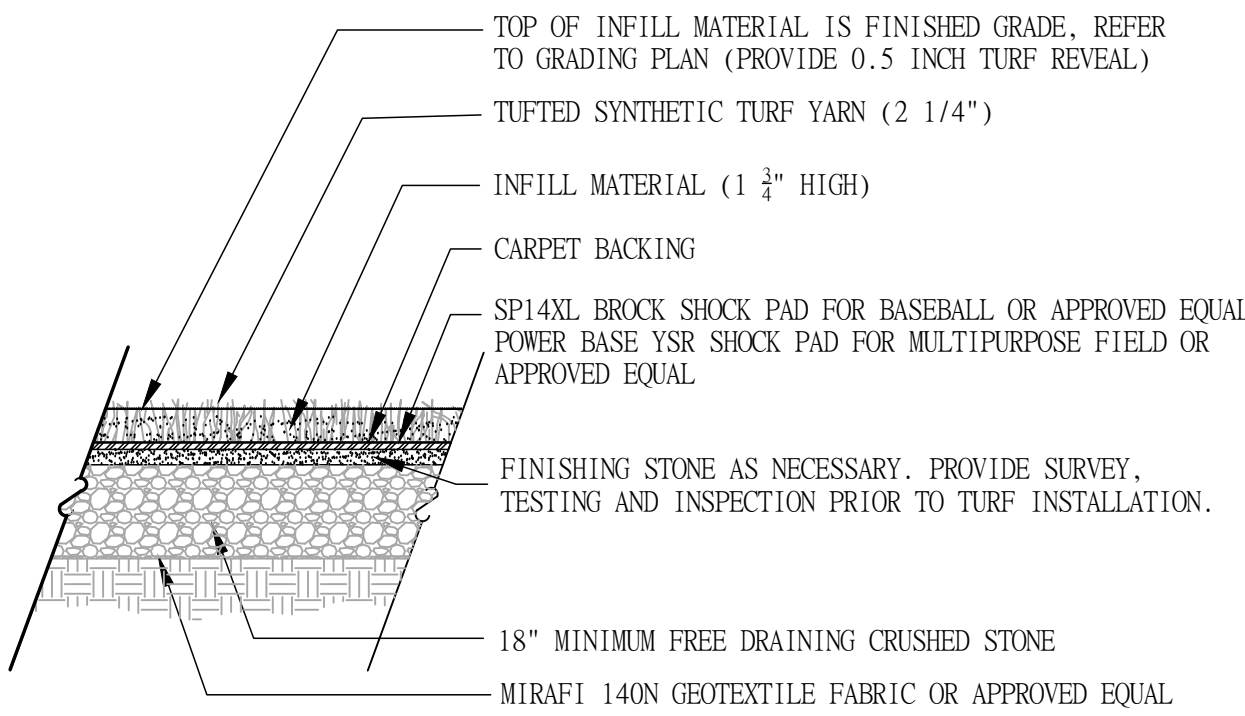

**INFILLED SYNTHETIC TURF SYSTEM DETAIL**  
N.T.S.

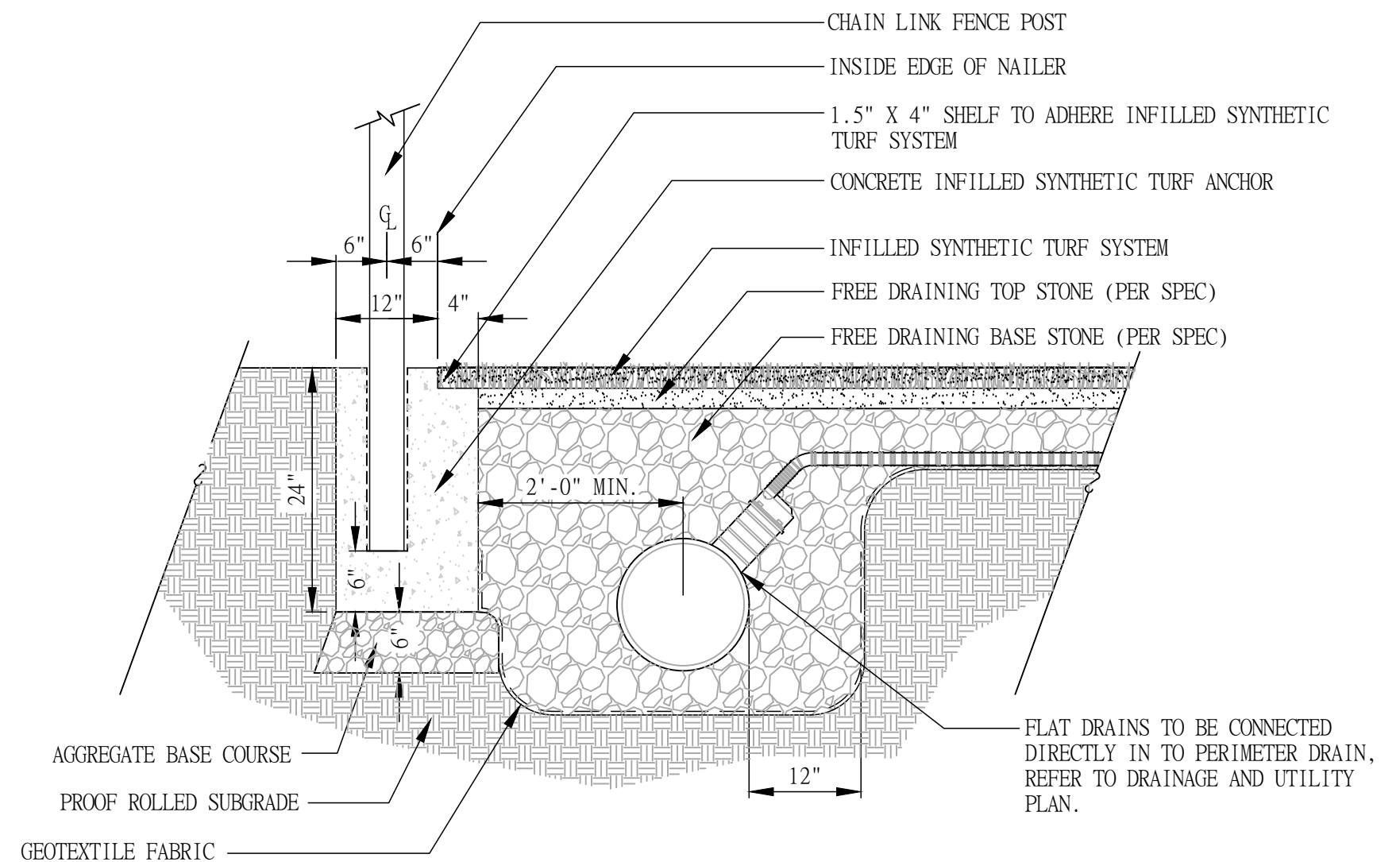

**4-FT CHAIN LINK FENCE IN TURF ANCHOR DETAIL**  
N.T.S.

**BIORETENTION NOTES:**

- THE USDA TEXTURAL CLASSIFICATION OF THE PLANTING SOIL FOR THE BIORETENTION SOIL MEDIA (BSM) SHALL BE LOAMY SAND OR SANDY LOAM. THE PLANTING SOIL SHALL BE SALVAGED OR FURNISHED. ADDITIONALLY, THE PLANTING SOIL SHALL BE TESTED AND MEET THE FOLLOWING CRITERIA:

ITEM	PERCENT BY WEIGHT	TEST METHOD
SAND (2.0-0.055 MM)	85-88%	AASHTO T88
SILT (0.050-0.002MM)	8-12%	AASHTO T88
CLAY (LESS THAN 0.002 MM)	0-2%	AASHTO T88
ORGANIC MATTER	3-5%	AASHTO T194

TEXTURAL ANALYSIS FOR THE PLANTING SOIL SHALL BE AS FOLLOWS:

ASTM E11 SIEVE SIZE	MINIMUM PASSING BY WEIGHT
2 IN.	100
NO. 4	90
NO. 10	80

- TWENTY PERCENT (20%) OF WELL AGED (6-12 MONTHS), WELL AERATED, LEAF COMPOST SHALL BE ADDED TO THE BIORETENTION SOIL MEDIA.
- AT LEAST 45 DAYS PRIOR TO THE START OF CONSTRUCTION OF BIORETENTION FACILITIES, THE CONTRACTOR SHALL SUBMIT THE SOURCE OF THE PLANTING SOIL FOR THE BSM TO THE ENGINEER FOR APPROVAL. NO TIME EXTENSIONS WILL BE GRANTED SHOULD THE PROPOSED PLANTING SOIL FAIL TO MEET THE MINIMUM REQUIREMENTS STATED ABOVE. ONCE A STOCKPILE OF THE PLANTING SOIL HAS BEEN SAMPLED, NO MATERIAL SHALL BE ADDED TO THE STOCKPILE.
- THE BIORETENTION SOIL MEDIA (BSM) SHALL BE A UNIFORM MIX, FREE OF STONES, STUMPS, ROOTS OR OTHER SIMILAR OBJECTS LARGER THAN TWO INCHES EXCLUDING MULCH. NO OTHER MATERIALS OR SUBSTANCES SHALL BE MIXED OR DUMPED WITHIN THE BIORETENTION AREA THAT MAY BE HARMFUL TO PLANT GROWTH, OR PROVE A HINDRANCE TO THE PLANTING OR MAINTENANCE OPERATIONS.
- THE PLANTING SOIL SHALL BE TESTED AND SHALL MEET THE FOLLOWING CRITERIA:

ITEM	CRITERIA
CORRECTED PH	5.5-7.5
MAGNESIUM MINIMUM	32 PPM
FRESH PHOSPHORUS (PHOSPHATE - P205)	NOT TO EXCEED 69 PPM
POTASSIUM (K2O)	MINIMUM 78 PPM
SOLUBLE SALTS	NOT TO EXCEED 500 PPM

- SHOULD THE PH FALL OUTSIDE OF THE ACCEPTABLE RANGE, IT MAY BE MODIFIED WITH LIME (TO RAISE) OR IRON SULFATE PLUS SULFUR (TO LOWER). THE LIME OR IRON SULFATE MUST BE MIXED UNIFORMLY INTO THE SOIL PRIOR TO USING IN BIORETENTION FACILITIES. SHOULD THE PLANTING SOIL NOT MEET THE MINIMUM REQUIREMENT FOR MAGNESIUM, IT MAY BE MODIFIED WITH MAGNESIUM SULFATE. LIKEWISE, SHOULD THE PLANTING SOIL NOT MEET THE MINIMUM REQUIREMENT FOR POTASSIUM, IT MAY BE MODIFIED WITH POTASH. MAGNESIUM SULFATE AND POTASH MUST BE MIXED UNIFORMLY INTO THE SOIL PRIOR TO USE IN BIORETENTION FACILITIES.
- PLANTING SOIL THAT FAILS TO MEET THE MINIMUM REQUIREMENTS SHALL BE REPLACED AT NO ADDITIONAL COST. MIXING OF THE CORRECTIVE ADDITIVES TO THE BSM IS INCIDENTAL AND SHALL BE AT NO ADDITIONAL COST.
- MIXING OF THE BSM TO A HOMOGENEOUS CONSISTENCY SHALL BE DONE TO THE SATISFACTION OF THE ENGINEER.
- THE MULCH LAYER SHALL BE SHREDDED HARDWOOD MULCH THAT IS WELL AGED (STOCKPILED OR STORED FOR AT LEAST SIX (6) MONTHS), UNIFORM IN COLOR, AND FREE OF OTHER MATERIALS SUCH AS WEED SEEDS, SOIL, ROOTS, ETC., THE MULCH SHOULD BE APPLIED TO A MAXIMUM DEPTH OF THREE INCHES. GRASS CLIPPINGS SHOULD NOT BE USED AS A MULCH MATERIAL.
- MULCH SHALL BE IN ACCORDANCE WITH THE "STANDARD SPECIFICATIONS FOR ROAD AND BRIDGE CONSTRUCTION" SECTION 1.02 AND ALL APPLICABLE SECTIONS.

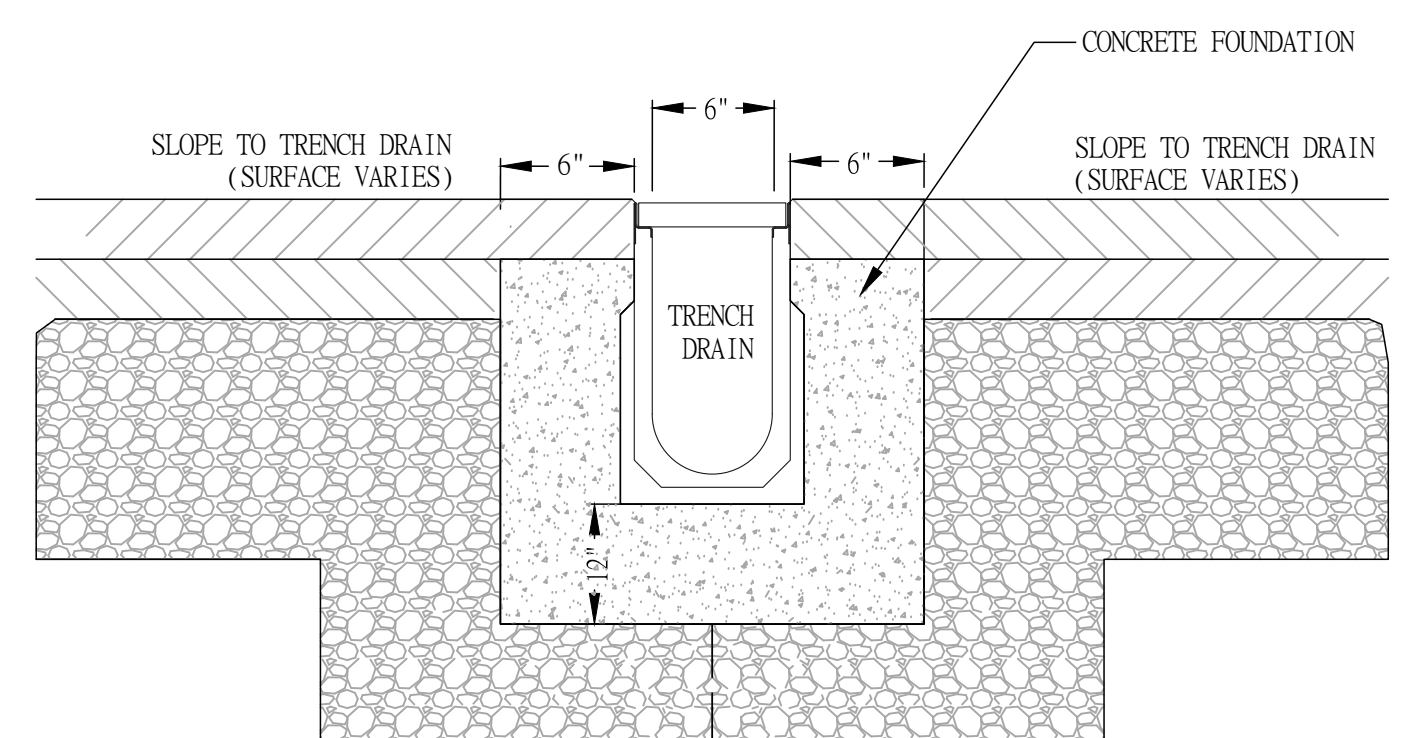

**TRENCH DRAIN DETAIL AT PAVED AREAS**  
N.T.S.

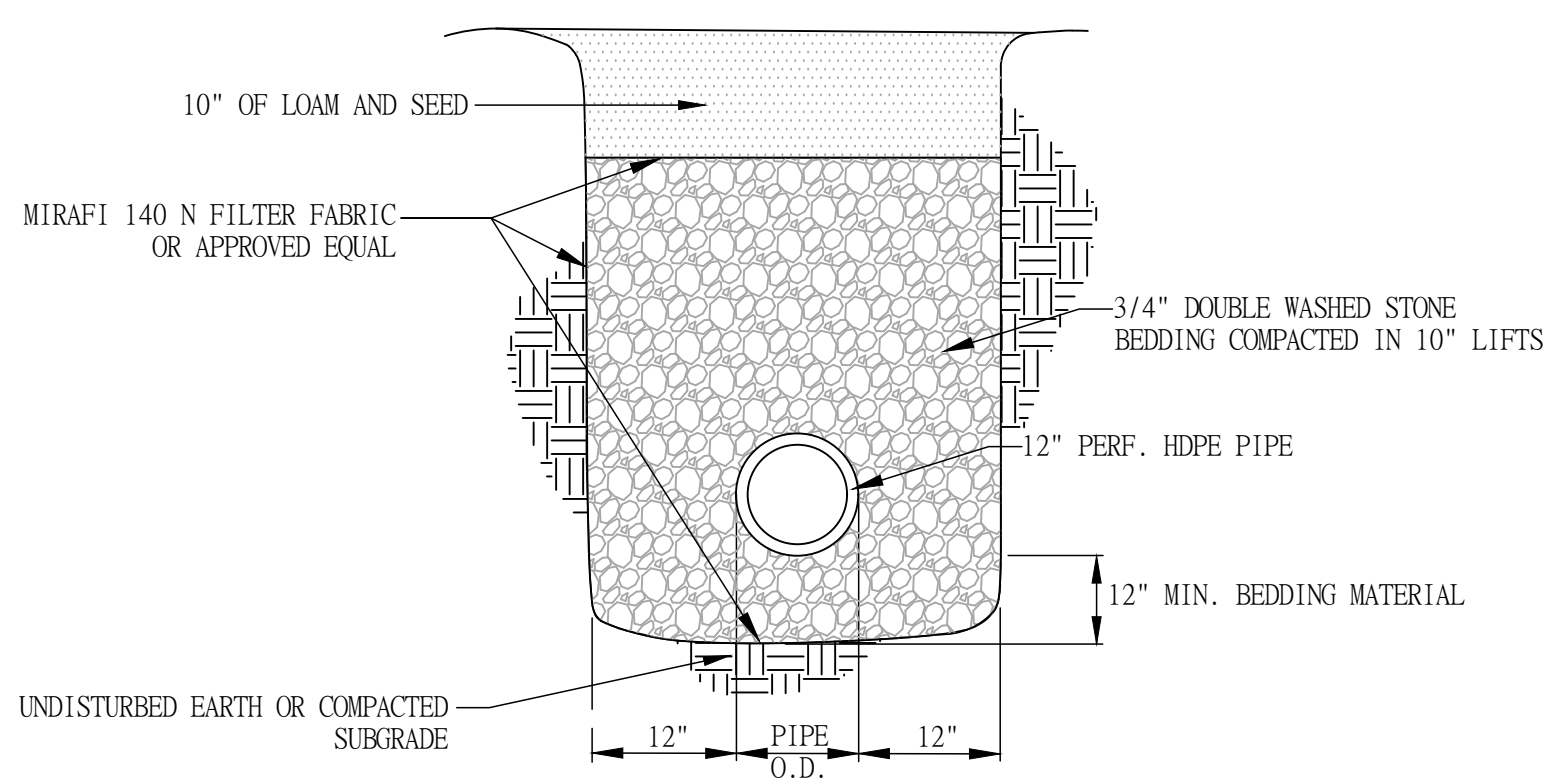

NOTE:  
1. CONTRACTOR SHALL PROVIDE SHEETING, TRENCH BOX OR SLOPED WALLS IN ACCORDANCE WITH APPLICABLE SAFETY REGULATIONS.

**HDPE TRENCH DETAIL FOR PERF. PIPE**  
N.T.S.

WWW.NESRAENG.COM  
607-506-3772

**ENGINEERING**

829 SOUTH WASHINGTON STREET  
NORTH ATTLEBORO  
MASSACHUSETTS 02760

**NESRA**

ARSEN HAMBARDZUMIAN  
No. 9734  
REGISTERED PROFESSIONAL ENGINEER

PROJECT  
LA SALLE ACADEMY JOHN P. CRONIN FIELD RENOVATION PROJECT, 612 ACADEMY AVE, PROVIDENCE, RI 02908

CLIENT  
LA SALLE ACADEMY  
612 ACADEMY AVE  
PROVIDENCE, RI 02908

**BID SET**

NO.	REVISION	DATE

SCALE - AS NOTED  
DATE - 9/15/25

PROFESSIONAL SEAL

**CONSTRUCTION DETAILS IV**

**C-13**

**ELECTRICAL LEGEND:**

- SPORTS LIGHTING
- ELECTRICAL HANDHOLE
- SURFACE PANELBOARD  
 LP - DENOTES PANEL DESIGNATION  
 BOUNDARY IN FRONT OF PANEL INDICATES ELECTRICAL WORKING SPACE (TYPICAL FOR PANELBOARDS, SWITCHGEAR, AUTOMATIC TRANSFER SWITCHES AND OTHER ELECTRICAL EQUIPMENT WHERE THIS BOUNDARY APPEARS, REFER TO NATIONAL ELECTRIC CODE 10.26)
- TRANSFORMER RATING AS INDICATED ON DRAWINGS DIMENSIONS VARY
- DUPLEX CONVENIENCE OUTLET, 20A 125V, 2 POLE, 3 WIRE, U SLOT GROUNDED TYPE MOUNTED 18" ABOVE FINISHED FLOOR (TO CENTER LINE) T INDICATES CIRCUIT NUMBER
- SUBTEXT KEY: (APPLICABLE TO ALL RECEPTACLE CONFIGURATIONS)  
 NL - INDICATES NIGHT LIGHT TYPE, HUBBEL #08BNLWH  
 EM - INDICATES RECEPTACLE ON EMERGENCY CIRCUIT, PROVIDE A RED DEVICE / FACEPLATE FOR EM LOCATIONS  
 WP - INDICATES WEATHER PROOF, PROVIDE WEATHER PROOF "IN-USE" COVER  
 LP - INDICATES RECEPTACLE PROVIDED WITH LIGHTED FACEPLATE
- GROUND FAULT INTERRUPTING (GFI) TYPE SELF-TESTING DUPLEX CONVENIENCE OUTLET MOUNTED 18" ABOVE FINISHED FLOOR  
 WP - DENOTES RECEPTACLE TO BE WEATHER RESISTANT TYPE AND TO BE PROVIDED WITH A WEATHER-PROOF IN-USE COVER SEE NOMENCLATURE ABOVE
- TEL/DATA OUTLET, MOUNTED IN COMBO ELECTRICAL CONTRACTOR SHALL FURNISH AND INSTALL A 4" SQUARE OUTLET BOX AND A SEPARATE PULL WIRE FOR VOICE AND DATA TO THE DEMARCATION POINT IN THE PRESS BOX

**ABBREVIATIONS & NOTATION**

- REVISION TAG  
1 - DENOTES REVISION NUMBER
- ABBREVIATIONS:
- AFF ABOVE FINISHED FLOOR
- AFG ABOVE FINISHED GRADE
- DW DISHWASHER
- EC ELECTRICAL CONTRACTOR
- EX EXISTING TO REMAIN
- ER EXISTING RELOCATED
- ED EXISTING TO BE DEMOLISHED
- ETR EXISTING TO BE RELOCATED
- EXR EXISTING TO BE REPLACED
- EXP EXPLOSION PROOF
- GC GENERAL CONTRACTOR
- IG ISOLATED GROUND
- MC MECHANICAL CONTRACTOR
- OFCI OWNER FURNISHED, CONTRACTOR INSTALLED
- PC PHOTOCELL
- TR TAMPER RESISTANT
- WP WEATHER-PROOF

- WIRING**
- HOMERUN - CABLE  
 LP1 - DENOTES PANELBOARD  
 L3 - DENOTES CIRCUITS  
 TICKS INDICATE NUMBER OF #2AWG CURRENT CARRYING CONDUCTORS IN THE RUN IN ADDITION TO A #2AWG GREEN INSULATED EQUIPMENT GROUNDING CONDUCTOR
  - HOMERUN - PPE. SEE NOMENCLATURE ABOVE
  - LOAD CENTER DESIGNATION T INDICATES WIRE & BREAKER SIZE/ RATING (SEE TYPICAL HOME RUN SCHEDULE)
  - CONDUIT TURNING LP
  - CONDUIT TURNING DOWN
  - CONDUIT STUB
  - WIRE BREAK
  - EXPLOSION PROOF "EY" FITTING W/ SEALING COMPOUND
  - NEW NORMAL POWER WIRING
  - NEW EMERGENCY POWER WIRING
  - NEW TEL/DATA WIRING
  - NEW LOW VOLTAGE / CONTROL WIRING
  - "MC" LUMINARY CABLE OR "NMW" W/ CHOC DIMMING CONTROL CABLE
  - NEW ISOLATED GROUND WIRING  
 TICK SETS (1 SHORT & 1 LONG) INDICATE NUMBER OF CONDUCTORS IN THE RUN
  - OUT OF FUNCTION LINE-WORK AND DEVICES INDICATE EXISTING WIRING AND/OR DEVICES (AS NOTED, SEE ABBREVIATIONS BELOW)

LOCATION: AS INDICATED PANEL: "HP" (EXISTING) VOLTAGE: 277/480V, 3Ø-4W 42k AIC  
 MOUNTING: SURFACE RATING: 400A TYPE OF MAIN: 400A MCB, 42 POLE

DESCRIPTION	VOLTAMPS			FRAME	TRIP	POLES	CKTS	POLES	TRIP	FRAME	VOLTAMPS			DESCRIPTION
	0A	0B	0C								0A	0B	0C	
"F1"	10K					70	3	1	2	3			10K	"F3"
---		10K						3	4				10K	---
---			10K					5	6					10K
"F2"	10K					60	3	7	8	3			10K	"F4"
---		10K						9	10				10K	---
---			10K					11	12					10K
EXISTING LOAD						20	2	13	14	3	20			EXISTING LOAD
---								15	16					---
EXISTING LOAD						20	2	17	18					EXISTING LOAD
---								19	20	2	20			EXISTING LOAD
EXISTING LOAD						100	2	21	22					---
---								23	24	1				SPACE
SPACE								25	26	1				SPACE
SPACE								27	28	1				SPACE
SPACE								29	30	1				SPACE
SPACE								31	32	1				SPACE
SPACE								33	34	1				SPACE
SPACE								35	36	1				SPACE
30kVA TRANSFORMER / "PB"	10K					50	3	37	38	3	100		19.3K	"F1"
---		10K						39	40				19.3K	---
---			10K					41	42				19.3K	---

LOCATION: AS INDICATED PANEL: "HP" VOLTAGE: 277/480V, 3Ø-4W 42k AIC  
 MOUNTING: SURFACE RATING: 100A TYPE OF MAIN: M.L.O., 42 POLE

DESCRIPTION	VOLTAMPS			FRAME	TRIP	POLES	CKTS	POLES	TRIP	FRAME	VOLTAMPS			DESCRIPTION
	0A	0B	0C								0A	0B	0C	
"C2"	2000					30	3	1	2	3	30		2700	"B2"
---		2000						3	4				2700	---
---			2000					5	6				2700	---
"A2"	1500					30	3	7	8	3	30		1500	"A1"
---		1500						9	10				1500	---
---			1500					11	12				1500	---
"BALLTRACKERS"	1200					30	3	13	14	3	30		2100	"D2"
---		1200						15	16				2100	---
---			1200					17	18				2100	---
"D1"	2100					30	3	19	20	3	30		2000	"C1"
---		2100						21	22				2000	---
---			2100					23	24				2000	---
"B1"	2700					30	3	25	26	3	30		1500	"BALLTRACKERS"
---		2700						27	28				1500	---
---			2700					29	30				1500	---
SPARE						20	1	31	32	1	20			SPARE
SPARE						20	1	33	34	1	20			SPARE
SPARE						20	1	35	36	1	20			SPARE
SPARE						20	1	37	38	1	20			SPARE
SPARE						20	1	39	40	1	20			SPARE
SPARE						20	1	41	42	1	20			SPARE

LOCATION: AS INDICATED PANEL: "LP" (EXISTING) VOLTAGE: 120/208V, 3Ø-4W 42k AIC  
 MOUNTING: SURFACE RATING: 225A TYPE OF MAIN: 225A MCB, 42 POLE

DESCRIPTION	VOLTAMPS			FRAME	TRIP	POLES	CKTS	POLES	TRIP	FRAME	VOLTAMPS			DESCRIPTION
	0A	0B	0C								0A	0B	0C	
FIELD PLUG BLEACHER SIDE						20	1	1	2	1	20			EXISTING LOAD
FIELD PLUG OPPOSITE SIDE						20	1	3	4	1	20			EXISTING LOAD
EXISTING LOAD						20	1	5	6	1	20			CONTROL FOR MUSCO CONTACTOR
FOOTBALL FLAG LIGHT / SCOREBOARD						20	1	7	8	1	20			EXISTING LOAD
EXISTING LOAD						20	1	9	10	1	20			EXISTING LOAD
EXISTING LOAD						20	1	11	12	1	20			EXISTING LOAD
EXISTING LOAD						20	1	13	14	2	100			CONCESSION BUILDING
NEW MUSCO CONTACTOR CABINET	1500					20	1	15	16					---
BASEBALL SCOREBOARD			500			20	1	17	18	1				SPACE
BATTING TUNNEL COMBO	1500					20	1	19	20	1				SPACE
SPACE								21	22	1				SPACE
SPACE								23	24	1				SPACE

**GENERAL NOTES**

1. PERFORM ALL WORK IN ACCORDANCE WITH NATIONAL AND STATE ELECTRICAL CODES, LOCAL ORDINANCES, AND REQUIREMENTS OF THE WIRING INSPECTOR. CODES INCLUDE BUT ARE NOT LIMITED TO:
  - a. NATIONAL BUILDING AND ELECTRICAL CODES
  - b. STATE CODES
  - c. LOCAL TOWN BY-LAWS AND AGENCY REQUIREMENTS.
2. MATERIALS
  - a. ALL WIRING SHALL BE COPPER, CONDUCTORS WITH AMPACITIES OF 100 AMPS OR LESS OR CONDUCTORS MARKED AWG #4 THROUGH #1 SHALL BE 60°C (UNLESS EQUIPMENT IS LISTED FOR HIGHER TEMPERATURES) CONDUCTORS OF HIGHER AMPACITIES OR LARGER GAUGES SHALL BE 75°C. REFER TO 2014 NEC (rt. 1015(C)(1)(A)). FOR TYPE "NM" CABLE, SEE PARAGRAPH (b) BELOW.
  - b. WHERE TYPES "NM", "NMB", "NMC" & "NMS" ARE USED, THEY SHALL HAVE AN ALLOWABLE AMPACITY AS LISTED IN THE 60°C (140°F) COLUMN IN THE 2014 NEC TABLE 310.15(B)(16). REFER TO 2014 NEC (rt. 334.80).
  - c. GENERAL BRANCH WIRING SHALL BE TYPE "MC" CABLE FOR INTERIOR WIRING. EXPOSED BRANCH CIRCUIT WIRING SHALL BE IN "EMT".
  - d. ALL PRODUCTS AND DEVICES SHALL BE NEW AND BEAR THE UNDERWRITERS' LABORATORIES LABEL. DEVICES SHALL BE SPECIFICATION GRADE. COLOR OF DEVICES SHALL BE COORDINATED WITH THE ARCHITECT.
3. PERFORM ALL WORK IN A WORKMANLIKE AND TIMELY MANNER SUBJECT TO THE APPROVAL OF THE ENGINEER.
4. ELECTRICAL CONTRACTOR SHALL BE RESPONSIBLE FOR ALL INSURANCE, PERMITS, FEES AND BACK-CHARGES REQUIRED FOR THE PERFORMANCE OF HIS/HER WORK.
5. ELECTRICAL CONTRACTOR SHALL COORDINATE THE ELECTRICAL WORK WITH ALL OTHER TRADES. ANY CONFLICT SHALL BE PRESENTED TO THE GENERAL CONTRACTOR AND ENGINEER PRIOR TO INSTALLATION OF WORK.
6. PANEL DIRECTORIES SHALL REFLECT THE WORK PERFORMED UNDER THIS CONTRACT. PANELS SHALL BE PROVIDED WITH TYPED DIRECTORIES.
7. ALL PRODUCTS SHALL BE GUARANTEED FOR ONE YEAR AFTER ACCEPTANCE BY OWNER.
8. ALL WIRING AND EQUIPMENT ARE DEPICTED DIAGRAMMATICALLY. FINAL LOCATIONS SHALL BE DETERMINED IN THE FIELD AND ANY CONFLICTS SHALL BE BROUGHT TO THE ATTENTION OF THE ENGINEER.
9. ELECTRICAL CONTRACTOR SHALL BE RESPONSIBLE FOR PROVIDING TEMPORARY POWER AND LIGHTING. SPECIAL PURPOSE POWER REQUIREMENTS SHALL BE PAID FOR BY THE TRADE REQUIRING SAME (WELDERS, COMPRESSORS, ETC.)
10. SHOP DRAWINGS SHALL BE SUBMITTED ON ALL ELECTRICAL EQUIPMENT, BEFORE PROCUREMENT OF EQUIPMENT.
11. ALL NEW WIRING INDICATED ON PLANS SHALL MATCH THE AMPACITY OF THE CIRCUIT BREAKER INDICATED AT THE HOMERUN, WHERE NO BREAKER SIZE IS INDICATED, THE BREAKER SHALL BE 20A/FP WITH #12 AWG CABLE.
12. WIRE AND CONDUIT SIZES INDICATED ON HOMERUNS SHALL RUN CONTINUOUS THROUGHOUT CIRCUIT.
13. CONDUITS AND CIRCUITRY INDICATED ON THE DRAWINGS ARE DIAGRAMMATIC ONLY. FINAL LOCATION OF CONDUITS SHALL BE FIELD COORDINATED SO AS TO AVOID CONFLICTS WITH OTHER TRADES.
14. ALL 120 VOLT BRANCH CIRCUITS WHEN 100 LINEAR FEET OR MORE FROM LAST OUTLET OR FIXTURE IN CIRCUIT TO RESPECTIVE PANELBOARDS SHALL BE A MINIMUM OF #10 AWG COPPER WIRES.
15. ALL 277 VOLT BRANCH CIRCUITS WHEN 200 LINEAR FEET OR MORE FROM LAST OUTLET OR FIXTURE IN CIRCUIT TO RESPECTIVE PANELBOARDS SHALL BE A MINIMUM OF #10 AWG COPPER WIRES.
16. THE ELECTRICAL CONTRACTOR SHALL FURNISH AND INSTALL ALL LIGHTING FIXTURES COMPLETE WITH MOUNTING ACCESSORIES TO MEET PROJECT CONDITIONS.
17. THE ELECTRICAL CONTRACTOR SHALL VERIFY FIXTURE MOUNTING AND EXACT LOCATIONS AGAINST LANDSCAPE ARCHITECTS PLANS AND DETAIL DRAWINGS.
18. ELECTRICAL CONTRACTOR SHALL BE RESPONSIBLE FOR A COMPLETE SELECTIVE ARC FLASH/ COORDINATION STUDY.

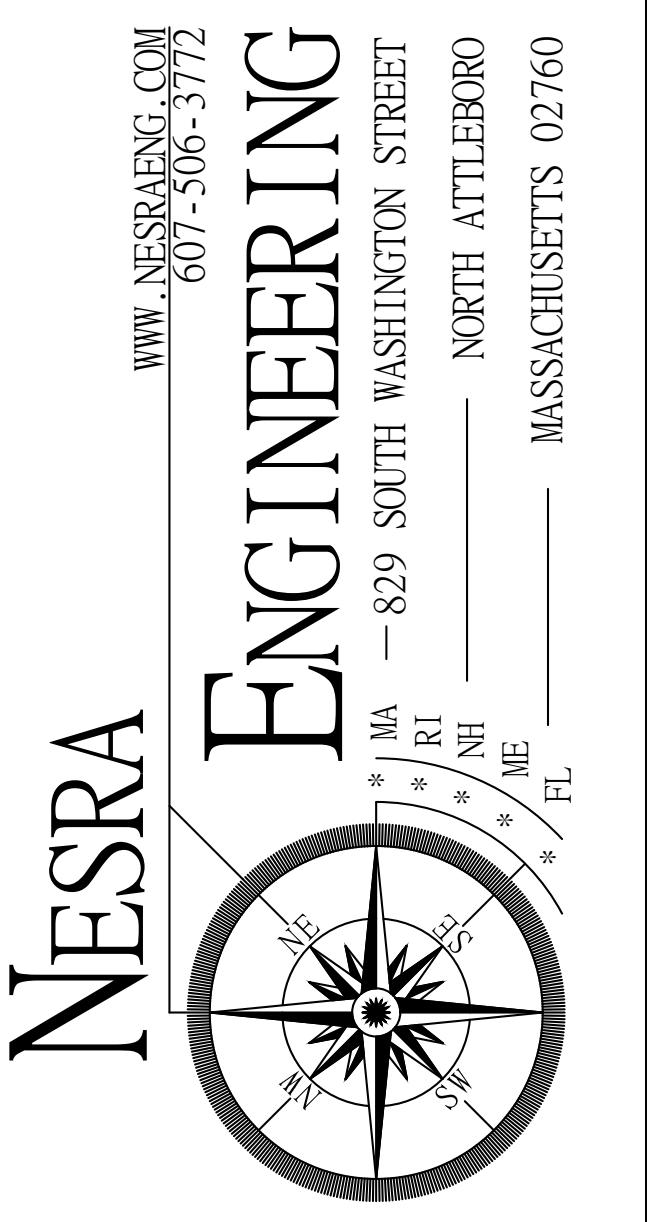

PROJECT

LA SALLE ACADEMY JOHN P. CRONIN FIELD RENOVATION PROJECT, 612 ACADEMY AVE, PROVIDENCE, RI 02908

CLIENT

LA SALLE ACADEMY 612 ACADEMY AVE PROVIDENCE, RI 02908

NO.	REVISION	DATE

SCALE - AS NOTED  
 DATE - JANUARY 5, 2026

PROFESSIONAL SEAL

ELECTRICAL LEGEND, NOTES & DETAILS

ESO. 1

## ELECTRICAL SPECIFICATIONS

ELECTRICAL CONTRACTOR SHALL FURNISH AND INSTALL ALL ELECTRICAL CONSTRUCTION MATERIALS SHOWN OR REASONABLY IMPLIED ON THE DRAWINGS TO COMPLETE THE INSTALLATION IN A SATISFACTORY AND USABLE MANNER.

ALL WORK SHALL BE IN A MANNER TO COMPLY WITH THE REQUIREMENTS OF THE TOWN OF WELLESLEY, THE WISES OF THE LOCAL FIRE DEPARTMENT AND ANY LOCAL OR STATE BODIES HAVING JURISDICTION.

ELECTRICAL CONTRACTOR SHALL OBTAIN A PERMIT AND PAY ALL PERMIT AND INSPECTION FEES FOR HIS WORK.

ALL MATERIALS SHALL BE NEW AND U.L. LISTED. THIS CONTRACTOR SHALL DO ALL CUTTING AND PATCHING REQUIRED AND SHALL REMOVE DEBRIS FROM THE SITE.

EQUIPMENT MANUFACTURERS SHALL BE NOTED ON THE DRAWINGS AND IN THE SPECIFICATIONS. ANY SUBSTITUTIONS SHALL BE APPROVED BY THE ARCHITECT/ENGINEER.

ALL FEEDER RUNS TO HAVE NO MORE THAN 4-90 DEGREE BENDS. PROVIDE HAND HOLES FOR FEEDER RUNS WITH MORE THAN 4-90 DEGREE BENDS OR OVER 160". ALL HAND HOLES TO BE IN ACCESSIBLE LOCATIONS.

CONDUIT BENDS TO HAVE MINIMUM RADIUS OF 10 TIMES THE DIAMETER OF THE CONDUIT.

ALL DISTRIBUTION CONDUIT OR CONDUIT INSTALLED 18" BELOW GRADE CONDUIT EXPOSED TO OUTDOOR WEATHER SHALL BE HEAVY WALL GALVANIZED STEEL. CONDUIT COUPLINGS SHALL BE COMPRESSION TYPE.

ALL DISCONNECT SWITCHES, POWER PANELS, AND CIRCUIT BREAKERS SHALL BE CLEARLY IDENTIFIED.

ALL ELECTRICAL EQUIPMENT AND WORK EXPOSED TO OUTSIDE WEATHER SHALL BE WEATHERPROOF NEMA 3R.

CONTRACTOR SHALL PURCHASE AND MAINTAIN SUCH INSURANCE THAT WILL PROTECT THE OWNER AND ENGINEER FROM AND AGAINST ANY CLAIMS, LOSS, COST OR DAMAGE FOR INJURY OR DEATH TO PERSONS OR DAMAGE TO PROPERTY INCLUDING COST OF LITIGATION AND ATTORNEY'S FEES IN ANY MANNER ARISING FROM INCIDENT TO, CONNECTED WITH, OR GROWING OUT OF THE WORK TO BE PERFORMED UNDER THIS CONTRACT. FURNISH CERTIFICATIONS OF INSURANCE IN THE AMOUNT REQUIRED BY THE OWNER AND LISTING THE OWNER AND THE ENGINEER TO BE HELD HARMLESS.

ALL POWER AND LIGHTING WIRE SHALL BE MINIMUM NO. 12 AWG COPPER OR AS OTHERWISE INDICATED ON THE DRAWINGS. (TYPE "THWN")

THIS CONTRACTOR SHALL SPECIFICALLY NOTE THAT THE ELECTRICAL DRAWINGS ARE INTENDED TO INDICATE ONLY THE EXTENT DIAGRAMMATICALLY. THE GENERAL LOCATION AND CHARACTER OF THE WORK INCLUDED, WORK INTENDED BUT HAVING MINOR DETAILS OBVIOUSLY OMITTED OR NOT SHOWN IN THE DRAWINGS ARE FOR IDENTIFICATION ONLY. THE BALANCING OF THE LOADS ON THE PANELS SHALL BE THE RESPONSIBILITY OF THE ELECTRICAL CONTRACTOR. ALL ELECTRICAL EQUIPMENT AND CONTROLS NOTED BY THE OWNER THROUGHOUT THE ELECTRICAL PLANS WILL BE FURNISHED BY ANOTHER DIVISION OF THE CONTRACT BUT SHALL BE RECEIVED AND INSTALLED BY THE ELECTRICAL CONTRACTOR.

ALL SIZES REGARDING PROTECTION FEEDERS, AND CONTROLS ARE BASED ON THE PRELIMINARY DESIGN DATA. ELECTRICAL CONTRACTOR TO REVIEW EXISTING AND NEW NAMEPLATE DATA, MOTOR RATINGS AND LOADS REQUIREMENTS AND PROVIDE ANY NEEDED ADJUSTMENTS.

THE CONTRACTOR SHALL VISUALLY SURVEY THE PREMISES BEFORE SUBMITTING HIS PROPOSAL AND IF THERE ARE ANY DISCREPANCIES BETWEEN THE DRAWINGS AND THE ACTUAL CONDITIONS HE SHALL CONSULT THE OWNER/ENGINEER FOR CLARIFICATION. ON SUBMISSION OF HIS PROPOSAL IT SHALL BE AGREED BY ALL PERSONS INVOLVED THAT THE WORK CAN BE AND WILL BE INSTALLED AS SHOWN OR AS MODIFIED IN WRITING BY THE OWNER/ENGINEER. ALSO, HE SHOULD FAMILIARIZE HIMSELF WITH THE SCHEDULE OF CONSTRUCTION SHOP DRAWINGS FOR ALL SPECIFIED EQUIPMENT, MATERIAL, ETC. SHALL BE SUBMITTED FOR APPROVAL PRIOR TO THE PROCUREMENT.

PROVIDE AN EQUIPMENT GROUNDING CONDUCTOR IN ALL DISTRIBUTION POWER EQUIPMENT AND PANELS.

EXACT LOCATION OF LIGHT FIXTURES SHALL BE COORDINATED IN THE FIELD.

ALL CONDUIT SHALL BE SIZED ACCORDING TO CODE UNLESS OTHERWISE NOTED ON THE DRAWINGS. MINIMUM SIZE TO BE USED IS 3/4".

ALL WORK SHALL BE PERFORMED IN STRICT ACCORDANCE WITH THE LATEST NATIONAL ELECTRICAL CODES, AS WELL AS THE LATEST MASSACHUSETTS ELECTRICAL CODE, LOCAL FIRE DEPARTMENT AND OSHA REQUIREMENTS.

ALL ELECTRICAL DRAWINGS ARE TO BE READ IN CONJUNCTION WITH THE PROJECT SPECIFICATIONS AND MANUFACTURERS EQUIPMENT DATA AND ALL OTHER DRAWINGS RELATED TO THE PERFORMANCE OF THE WORK.

ALL ELECTRICAL EQUIPMENT (LIGHT FIXTURES, PANELS, CONDUIT, WIRE, ETC) AND RACEWAY SHALL BE PROPERLY SUPPORTED WITHIN TRENCHES.

THE CONTRACTOR SHALL GUARANTEE ALL OF HIS WORK FOR ONE YEAR AFTER THE DATE OF WRITTEN ACCEPTANCE BY THE OWNER AGAINST ALL DEFECTS IN MATERIAL AND WORKMANSHIP. ALL SUCH DEFECTS APPEARING WITHIN THE GUARANTEE PERIOD SHALL BE PROMPTLY REMEDIATED WITHOUT COST TO OWNER. ALL ELECTRICAL EQUIPMENT INSTALLATIONS SHALL BE GUARANTEED TO OPERATE SATISFACTORY. THE CONTRACTOR MUST VERIFY EXISTING CONDITIONS AND LOCATIONS IN THE FIELD PRIOR TO SUBMITTING A PROPOSAL. FAILURE TO DO SO SHALL NOT RELIEVE THE CONTRACTOR FROM PERFORMING THE WORK REQUIRED UNDER THIS CONTRACT.

THE CONTRACTOR SHALL ADJUST HIS WORK AS REQUIRED TO AVOID CONDITIONS NOT SHOWN ON PLANS WITHOUT ANY FURTHER COST TO THE OWNER.

THE CONTRACTOR AFTER INSPECTING THE PREMISES AND THE DRAWINGS SHALL CALL TO THE ATTENTION OF THE ENGINEER ANY LACK OF THE SPACE OR CLEARANCE REQUIRED BY THE VARIOUS EQUIPMENT BEFORE THE CONTRACT IS SIGNED.

THE CONTRACTOR SHALL REMOVE RUBBISH AND DEBRIS RESULTING FROM HIS WORK ON A DAILY BASIS. THE JOB SITE MUST BE LEFT CLEAN AND TIDY AT THE END OF EACH WORKDAY. RUBBISH NOT REMOVED BY THE CONTRACTOR WILL BE REMOVED BY THE GENERAL CONTRACTOR AND THERE WILL BE BACK CHARGES TO THE CONTRACTOR.

ALL CONDUIT, RACEWAY, AND ELECTRICAL APPARATUS SHALL BE INSTALLED AS NEATLY AS POSSIBLE AND IN SUCH A MANNER AS TO AFFORD MINIMUM INTERFERENCE WITH OTHER TRADES.

ALL CONDUIT SHOULD BE SUPPORTED A MINIMUM OF 6 FEET ON CENTER AND WITHIN 5 FEET OF COUPLINGS IN COMPLIANCE WITH CODE REQUIREMENTS.

ALL JUNCTION BOXES AND SUPPORT BOXES ARE TO BE SUPPORTED

NO FLEXIBLE ELECTRICAL METALLIC CONDUIT (GREENFIELD) SMALLER THAN 1/2 INCH SHALL BE USED UNLESS SPECIAL PERMISSION IS GRANTED.

THE AMPACITY OF THE MULTIPLE CONDUCTORS IN ONE CONDUIT SHALL BE RATED PER NEC TABLE 310(B)(3)(D).

ALL CONDUIT BREAKERS SHALL BE THE BOLT-ON TYPE.

ALL LIGHT SWITCHES AND RECEPTACLES ARE TO BE RATED FOR 20 AMPS, MINIMUM.

ANY EQUIPMENT, RECEPTACLES, OR ANY LIGHT FIXTURES INSTALLED MUST BE IDENTIFIED ON THE DIRECTORY CARD WITH THE DATE IN THE ELECTRICAL AND POWER PANELS.

WHEN INSTALLING ELECTRICAL PANELS, IT IS THE RESPONSIBILITY OF THE CONTRACTOR TO IDENTIFY ALL THE CIRCUITS ON THE DIRECTORY CARD WITH THE DATE.

COLOR CODE FOR CONDUCTORS FOR SECONDARY FEEDERS AND BRANCH CIRCUITS ARE TO BE AS INDICATED BELOW:

PHASE	120/208 VOLT	277/480
A-----	BLACK	BROWN
B-----	RED	ORANGE
C-----	BLUE	YELLOW
NEUTRAL	WHITE	GRAY
GROUND	GREEN	GREEN

ELECTRICAL METALLIC CONDUIT ALONG WITH COMPRESSION CONNECTORS AND COUPLINGS MAY BE USED IN DRY AREAS ONLY.

TO ASSURE EFFECTIVE GROUNDING, ALL CONDUIT, EQUIPMENTS, AND METAL ENCLOSURE SHALL HAVE A CONTINUOUS PATH TO GROUND WITH SUFFICIENTLY LOW IMPEDANCE TO LIMIT THE POTENTIAL ABOVE GROUND, AND TO FACILITATE THE OPERATION OF THE OVER CURRENT DEVICES IN THE CIRCUITS.

STANDARD WIRING SHALL BE OF THIN INSULATION AND THIN INSULATION FOR AREAS WITH HIGH MOISTURE. NO TW INSULATION IS PERMITTED.

THE PROJECT WILL NOT BE CONSIDERED COMPLETE UNTIL AS-BUILT DRAWINGS WITH HOME RUNS IDENTIFIED ARE RECEIVED BY THE OWNER.

ALL CONTRACTORS MUST FOLLOW STANDARD OSHA LOCK-OUT AND TAG-OUT PROCEDURES.

WHERE A CONFLICT ARISES BETWEEN THE SPECIFICATIONS AND THE DRAWINGS THE WORST CASE SCENARIO SHALL PREVAIL.

ALL DISTRIBUTION EQUIPMENT AND PANELBOARDS SHALL BE MANUFACTURED BY EATON / CUTLER HAMMER.

ELECTRICAL CONTRACTOR SHALL BE RESPONSIBLE FOR A COORDINATION/ARC-FLASH STUDY AS PART OF THIS CONTRACT.

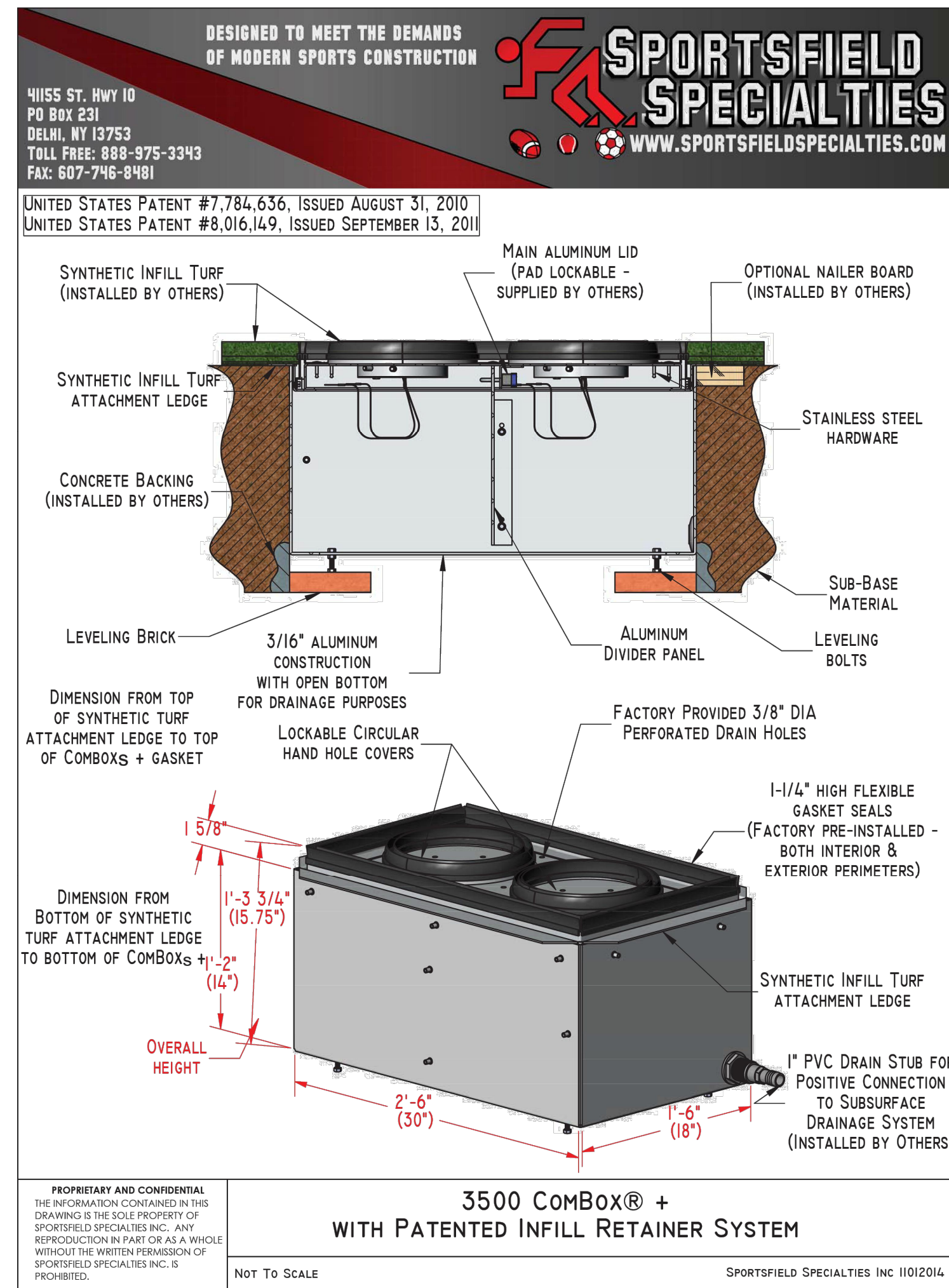

**COM-BOX DETAIL**  
SCALE: NOT TO SCALE

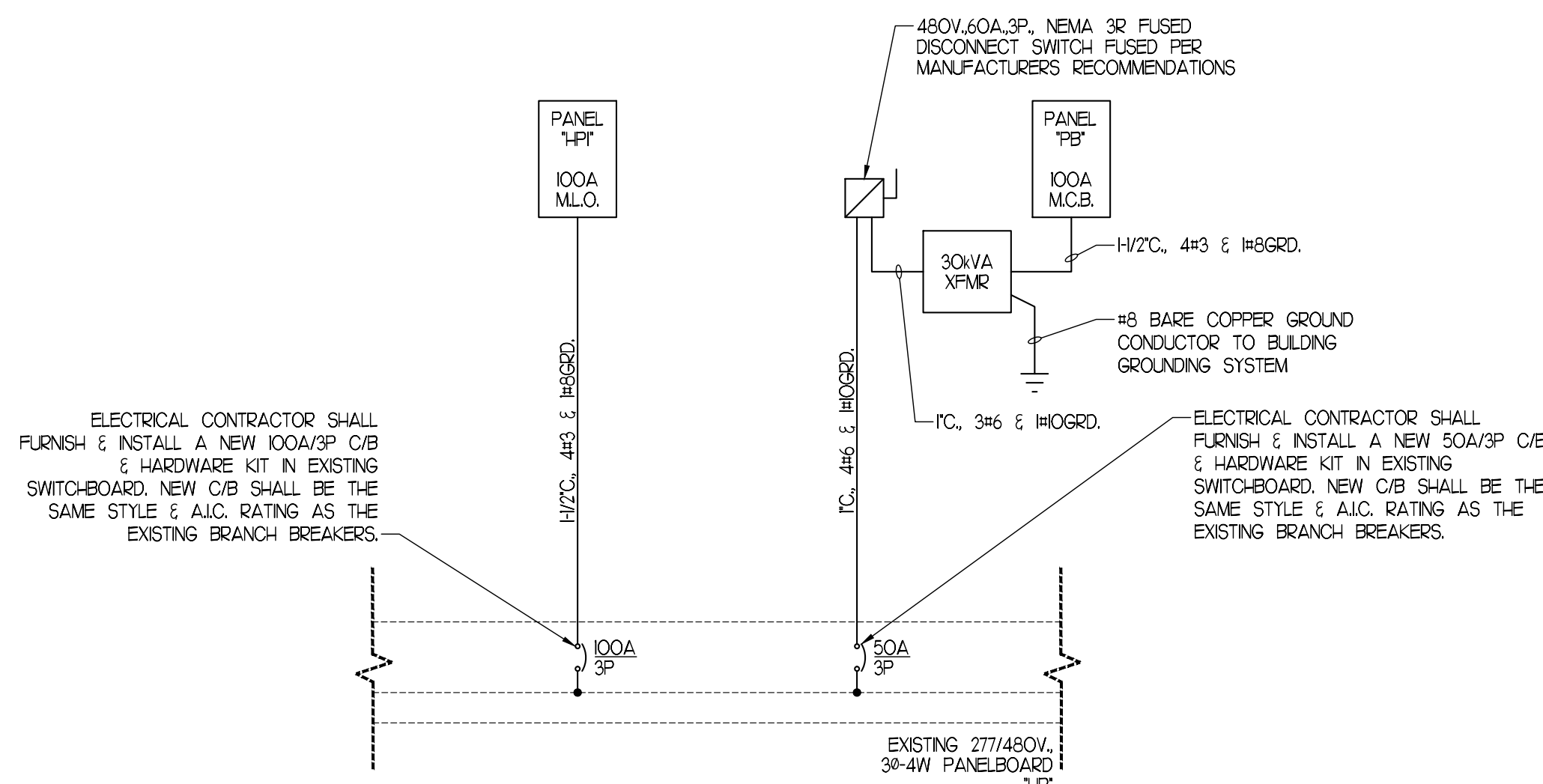

**POWER ONE-LINE DIAGRAM**  
SCALE: NOT TO SCALE

**VA** est. 1972  
**VINCENT A. DIORIO, INC.**  
CONSULTING ENGINEERS  
89 Access Rd., Suite 18  
Norwood, MA 02062  
(781)255-9754 | vadi@vadeng.com  
www.vadeng.com

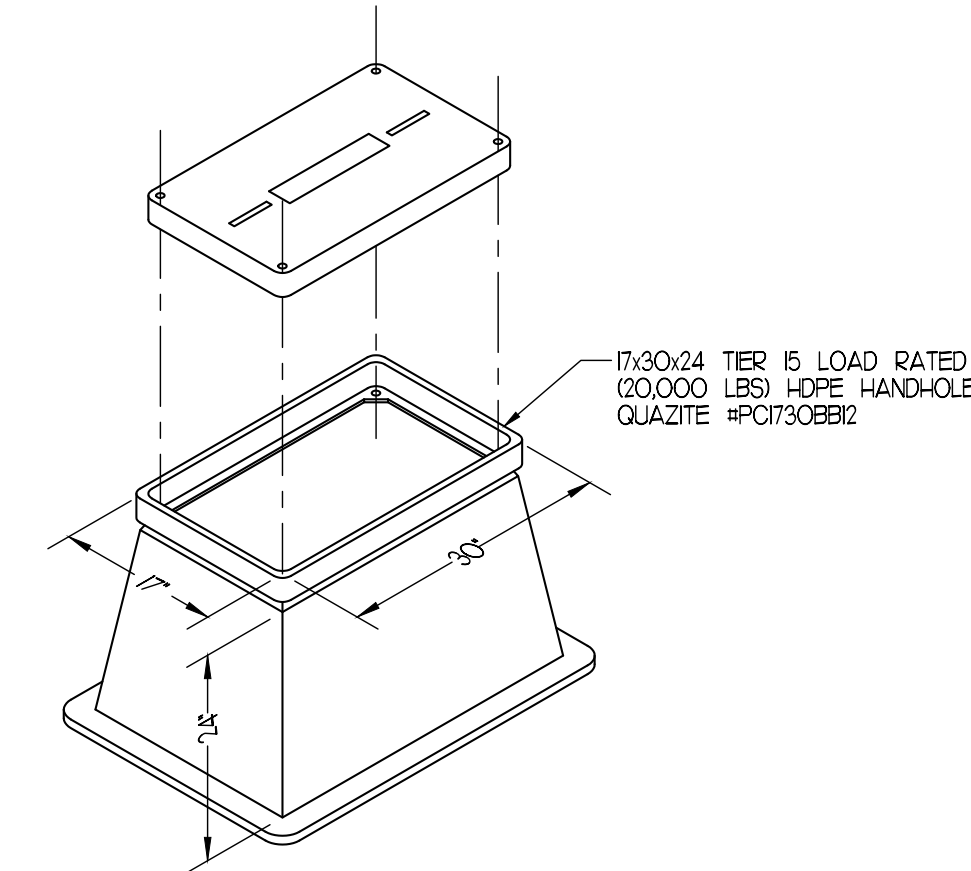

**HANDHOLE**  
SCALE: NOT TO SCALE

### HANDHOLE NOTES:

- THE LOCATION OF OUTLETS SHOWN ON DRAWINGS IS APPROXIMATE. THE ELECTRICAL CONTRACTOR SHALL STUDY THE PLANS IN RELATION TO THE AREAS AND EQUIPMENT SURROUNDING EACH HAND HOLE SO THAT HAND HOLES OR OTHER ELECTRICAL COMPONENTS ARE SYMMETRICALLY LOCATED AND ARE IN LINE WITH ONE ANOTHER FOR EASE OF PULLING CONDUCTORS.
- HAND HOLES OR PULL BOXES, SHOWN ON THE DRAWINGS, THAT INTERFERE WITH THE INSTALLATION OF SUB-SURFACE UTILITIES, STRUCTURAL POLE BASES OR ARCHITECTURAL FEATURES, OR THAT WILL BE INACCESSIBLE DUE TO THE WORK OF OTHER TRADES SHALL BE RELOCATED ACCORDINGLY.
- HAND HOLES, JUNCTION OR PULL BOXES THAT ARE NOT SPECIFICALLY SHOWN ON THE DRAWINGS BUT ARE REQUIRED FOR THE PROPER INSTALLATION OF THE ELECTRICAL SYSTEM SHALL BE INSTALLED BY THE ELECTRICAL CONTRACTOR, SO THAT THEY DO NOT INTERFERE WITH THE STRUCTURAL OR ARCHITECTURAL FEATURES AND THE INSTALLATION OF MATERIALS BY THE OTHER TRADES.
- ANY REASONABLE CHANGE IN THE LOCATION OF HAND HOLES OR JUNCTION BOXES REQUESTED BY THE ENGINEER, PRIOR TO ROUGHING, SHALL NOT INVOLVE ADDITIONAL EXPENSE TO THE OWNER.
- ALL HAND HOLES SHALL BE INSTALLED SO THAT THE COVER OF EACH HAND HOLE IS AT FINISHED GRADE.
- FEEDERS AND BRANCH CIRCUITS PASSING THROUGH HAND HOLES SHALL BE INDIVIDUALLY GROUPED AND BOUND WITH TIE-RAPS. THE FEEDERS AND BRANCH CIRCUITS IN EACH HAND HOLE SHALL BE PROPERLY TAGGED TO CLEARLY INDICATE THEIR ELECTRICAL CHARACTERISTICS, CIRCUIT NUMBER AND PANEL DESIGNATION. CABLES SHALL BE SUPPORTED ON SUITABLE RACKS WITHIN THE BOXES AND ARRANGED IN AN ORDERLY MANNER.
- HAND HOLES SHALL, IN GENERAL, BE AS FOLLOWS:
  - HAND HOLES SHALL BE A MINIMUM OF 17" X 30" X 18" DEEP WITH STRAIGHT SIDED AND A GASKETED COVER.
  - HAND HOLES SHALL BE FLUSH WITH GRADE AND COMPLY WITH THE 2023 NATIONAL ELECTRIC CODE.
  - EACH HAND HOLE SHALL BE MADE OF POLYMER CONCRETE AND BE STABLE UNDER FREEZE AND THAW CONDITIONS.
  - EACH HAND HOLE SHALL BE IMPACT RESISTANT AS TESTED PER ASTM D-244 AND BE LOW WATER ABSORPTION, CORROSION RESISTANT, NON-FLAMMABLE AND NONCONDUCTIVE.
  - EACH HAND HOLE SHALL BE PROVIDED WITH A BOLTED, GASKETED TIER 15 COVER. THE HARDWARE SHALL BE STAINLESS STEEL.
  - EACH HAND HOLE COVER SHALL BE EMBOSSED WITH THE WORD "ELECTRICAL".
  - EACH HAND HOLE SHALL BE MANUFACTURED BY OLDCASTLE INFRASTRUCTURE #1730F OR EQUAL.
- HAND HOLES SHALL BE PROPERLY SEALED DURING THE COURSE OF CONSTRUCTION TO PREVENT THE ENTRANCE OF DIRT AND FOREIGN MATERIALS.
- EXPOSED, SURFACE MOUNTED OUTLET BOXES OR OUTLET BOXES INSTALLED IN NORMALLY WET LOCATIONS SHALL BE OF THE CAST METAL TYPE WITH THREADED HUBS AS MANUFACTURED BY PASS & SEYMOUR/LEGRAND, GROUSE-HINDS OR RED DOT.
- OUTLET BOXES SHALL NOT BE LESS THAN 1/2 INCHES DEEP UNLESS SHALLOWER BOXES ARE REQUIRED BY STRUCTURAL CONDITIONS AND ARE SPECIFICALLY APPROVED BY THE ENGINEER.
- OUTLET BOXES ON THE EXTERIOR OF ANY STRUCTURE SHALL BE PROVIDED WITH U.L. LISTED WEATHERPROOF COVERS THAT ALLOW A PLUG TO BE IN PLACE WITH THE COVER IN CLOSED POSITION. COVERS SHALL BE SINGLE GANG, HORIZONTAL DUPLEX, (UNLESS) APPLICATION IN ACCORDANCE WITH ARTICLE 406 OF THE NATIONAL ELECTRIC CODE AND AS MANUFACTURED BY PASS & SEYMOUR/LEGRAND.

**NESRA**  
ENGINEERING  
829 SOUTH WASHINGTON STREET  
NORTH ATTLEBORO  
MASSACHUSETTS 02760



### PROJECT

LA SALLE ACADEMY JOHN  
P. CRONIN FIELD  
RENOVATION PROJECT,  
612 ACADEMY AVE,  
PROVIDENCE, RI 02908

### CLIENT

LA SALLE ACADEMY  
612 ACADEMY AVE  
PROVIDENCE, RI 02908

NO.	REVISION	DATE
-----	----------	------

SCALE - AS NOTED  
DATE - JANUARY 5, 2026

PROFESSIONAL SEAL

**ELECTRICAL  
SPEC., DETAILS  
& ONE-LINE**

**ES0.2**

UPDATED 1/7/26

**VA** est. 1972  
**VINCENT A. DIORIO, INC.**  
CONSULTING ENGINEERS  
89 Access Rd., Suite 18  
Norwood, MA 02062  
(781)255-9754 | vadi@vadeng.com  
www.vadeng.com

WWW.NESRAENG.COM  
607-506-3772  
**ENGINEERING**  
MA RI NH ME VT  
— 829 SOUTH WASHINGTON STREET  
NORTH ATTLEBORO  
MASSACHUSETTS 02760

**NESRA**

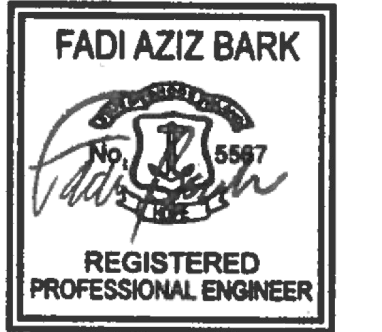
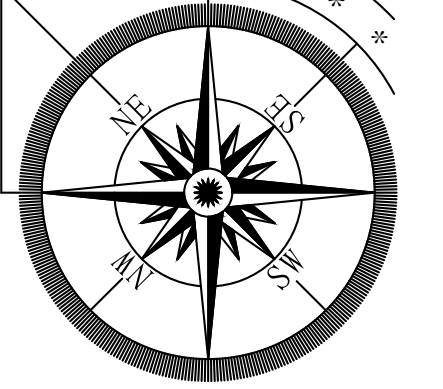

PROJECT

LA SALLE ACADEMY JOHN  
P. CRONIN FIELD  
RENOVATION PROJECT,  
612 ACADEMY AVE,  
PROVIDENCE, RI 02908

CLIENT

LA SALLE ACADEMY  
612 ACADEMY AVE  
PROVIDENCE, RI 02908

NO. REVISION DATE

SCALE - AS NOTED  
DATE - JANUARY 5, 2026

PROFESSIONAL SEAL

SITE PLAN

ES1.0

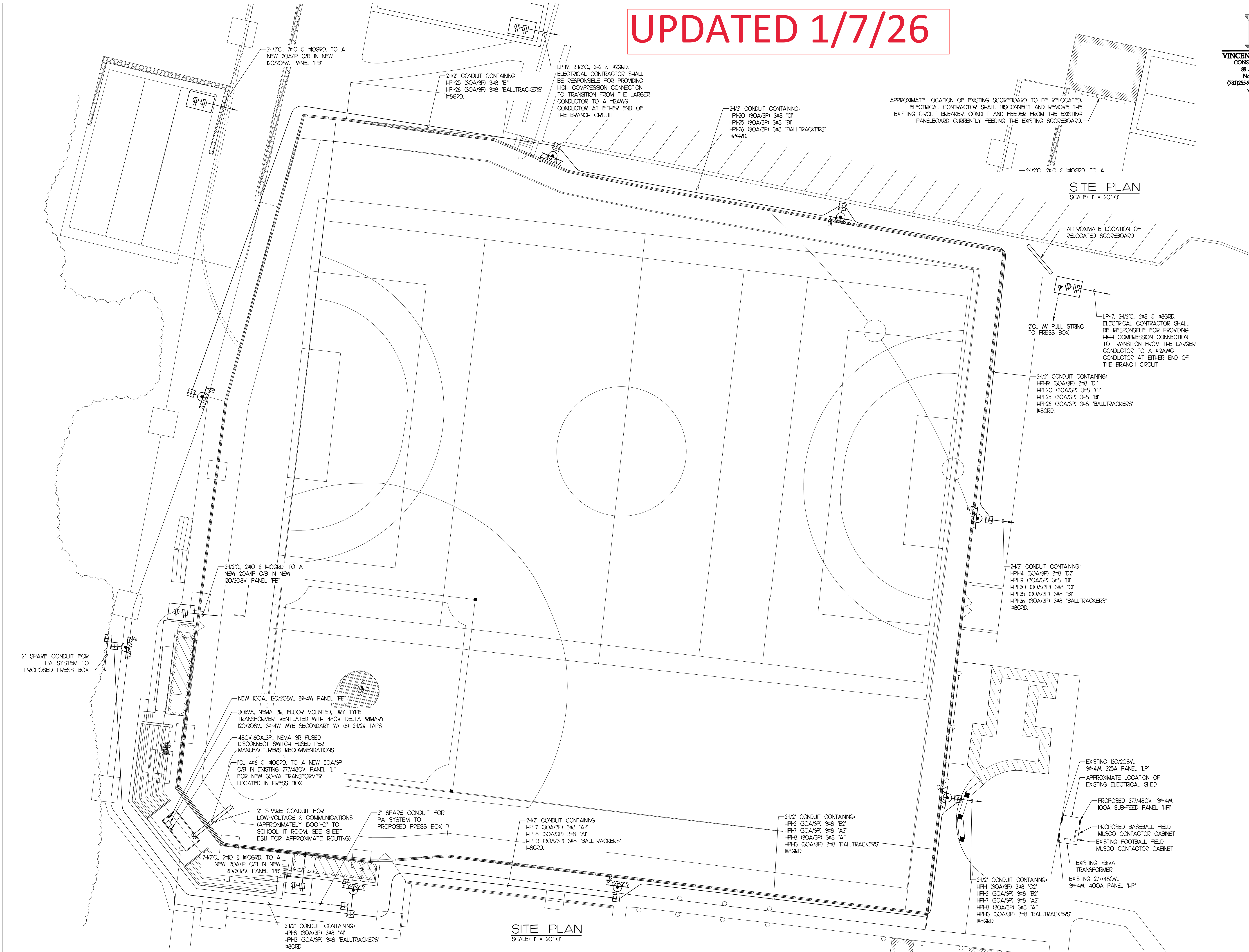

SITE PLAN  
SCALE: 1" = 20'-0"

NEW: 1/7/26

**V.A.** est. 1972  
**VINCENT A. DIORIO, INC.**  
 CONSULTING ENGINEERS  
 89 Access Rd. Suite 18  
 Norwood, MA 02062  
 (781)255-9754 | vadij@vadieng.com  
 www.vadieng.com

www.nesraeng.com  
 607-506-3772  
**ENGINEERING**  
 829 SOUTH WASHINGTON STREET  
 NORTH ATTLEBORO  
 MASSACHUSETTS 02760

MA \* RI \* NH \* ME \* VT \* CT \* NY \* NJ \* PA \* OH \* WV \* VA \* NC \* SC \* GA \* FL



PROJECT

LA SALLE ACADEMY JOHN  
 P. CRONIN FIELD  
 RENOVATION PROJECT,  
 612 ACADEMY AVE,  
 PROVIDENCE, RI 02908

CLIENT

LA SALLE ACADEMY  
 612 ACADEMY AVE  
 PROVIDENCE, RI 02908

NO.	REVISION	DATE

SCALE - AS NOTED  
 DATE - JANUARY 5, 2026

PROFESSIONAL SEAL

DATA ROUTING  
 SITE PLAN

ES1.1



**DUCTBANK SECTION KEY:**

- SEE POWER ONE-LINE FOR ADDITIONAL CONDUITS THAT MAY BE NEEDED IN EACH DUCTBANK.
  - PROVIDE CONDUIT SPACERS (CARLON #SP4W30-2) IN PRIMARY DUCTBANKS AT 6' INTERVALS OR OTHER APPROVED METHODS TO MAINTAIN SPACING AS INDICATED. SEE ALSO (NEC FIGURE 315.6(D)(13)).
- 1" 5" SCHED. 80 PVC PRIMARY ELECTRIC CONDUIT (VERIFY CONDUIT DIAMETER WITH UTILITY COMPANY)
  - 4" SCHED. 40 PVC SECONDARY CONDUIT
  - 4" SCHED. 40 PVC EMERGENCY CONDUIT
  - 4" SCHED. 40 PVC TELEPHONE CONDUIT
  - 4" SCHED. 40 PVC CATV CONDUIT
  - 2-1/2" SCHED. 40 PVC FIRE PUMP SERVICE CONDUIT
  - 4" SCHED. 40 PVC SPARE CONDUIT

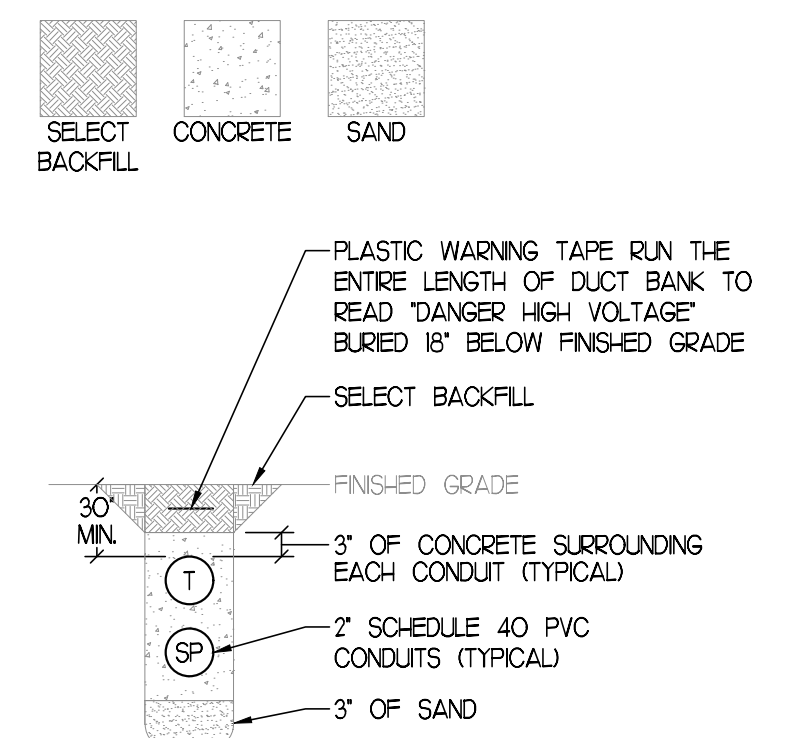

DUCTBANK SECTION "E-E"  
 NOT TO SCALE

SITE PLAN  
 SCALE: 1" = 20'-0"













# Radius Map - 612 Academy Avenue

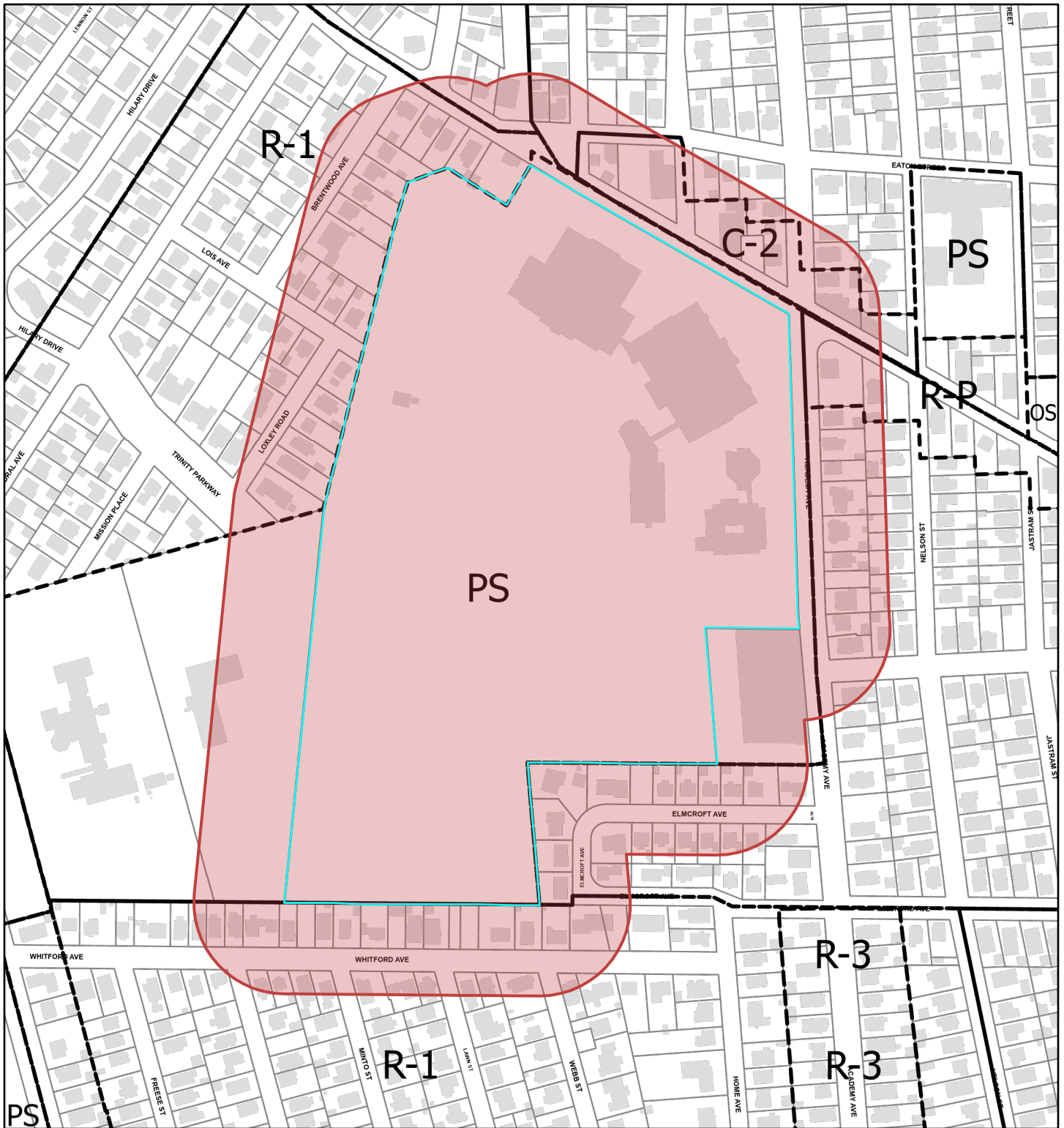

6/10/2026, 12:11:00 PM

1:4,990

- Override 1
- Zoning
- Override 1
- Parcels
- Plat Boundaries
- Buildings

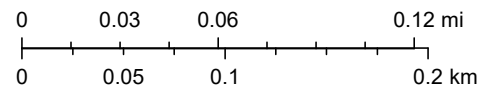

**QUITCLAIM DEED**

**LA SALLE ACADEMY**, a Rhode Island non-profit corporation, having an address c/o Diocese of Providence, One Cathedral Square, Providence, Rhode Island 02903 (the "Grantor"), for consideration paid in the amount of Six Million Seven Hundred Fifty Thousand and No/100 Dollars (\$6,750,000.00), the receipt and sufficiency of which is hereby acknowledged, hereby grants to **ST. JOHN BAPTIST DE LA SALLE INSTITUTE**, a Rhode Island non-profit corporation, having an address at 612 Academy Avenue, Providence, Rhode Island 02908 (the "Grantee"), with **QUITCLAIM COVENANTS**:

Those certain tracts or parcels of land with all buildings and improvements thereon, situated in the City and County of Providence, State of Rhode Island, more fully described on Exhibit A attached hereto and by this reference incorporated herein.

Subject only to those matters of record set forth on Exhibit B attached hereto and by this reference incorporated herein.

Being the same premises conveyed to this Grantor by Deed recorded in Book 4011 at Page 38.

Being designated as Lot 276 on Assessor's Plat 83 on the City of Providence Tax Assessor's Plats, as presently constituted and for informational purposes only.

The undersigned Grantor does hereby certify that no withholding is required pursuant to Section 44-30-71.3 as the Grantor is a resident non-profit corporation as evidenced by Seller's Residency Affidavit.

(Signature and Acknowledgment on Next Page)

JJ

REAL ESTATE

013581

TAX \$ 31,050  
DATE 10-19-18  
FOR [Signature]

IN WITNESS WHEREOF, the Grantor has caused this Quitclaim Deed to be duly executed on the 18<sup>th</sup> day of October, 2018.

LA SALLE ACADEMY, a Rhode Island non-profit corporation

By T. J. Tobin  
Most Reverend Thomas J. Tobin, D.D.  
President

STATE OF RHODE ISLAND

COUNTY OF PROVIDENCE

On October 18, 2018, before me, the undersigned notary public, personally appeared Most Reverend Thomas J. Tobin, D.D., President of La Salle Academy, a Rhode Island non-profit corporation, proved to me through satisfactory evidence of identification, being (check whichever applies):  driver's license or other state or federal governmental document bearing a photographic image,  oath or affirmation of a credible witness known to me who knows the above signatory, or  my own personal knowledge of the identity of the signatory, to be the person whose name is signed above, and acknowledged the foregoing to be signed by him voluntarily for its stated purpose, in his capacity as aforesaid, and the free act and deed of said non-profit corporation. Before me.

Eugene G. Bernier II  
Notary Public  
Print Name Eugene G. Bernier II  
My Commission expires 6/12/21



**EXHIBIT A**

A tract of land located along the southerly sideline of Smith Street; said tract of land being or more particularly shown and described on a plan of land entitled: "Boundary Plan" 612 Academy Avenue, Providence, Rhode Island; prepared by: InSite Engineering Services, LLC; Dated: May 15, 2018, said tract of land being more particularly described as follows:

Beginning at the northwest corner of parcel being described, said point located in the southerly line of Smith Street at an iron rod and being the POINT OF BEGINNING; thence running

- S 58°57'32" E 320.25 feet along Smith Street to a corner marked by a granite bound; thence running
- S 60°26'37" E 338.79 feet along Smith Street to a corner marked by a drill hole; thence running
- S 01°50'42" E 660.84 feet along Academy Avenue to an angle point; thence running
- S 05°01'39" E 30.23 feet along Academy Avenue to a corner marked by a drill hole; thence running
- N 89°36'39" W 400.00 feet to a corner marked by an iron rod; thence running
- S 05°01'39" E 300.00 feet to a corner marked by a granite bound, the last 2 courses bounded southerly and easterly by land and now or formerly of the Providence Public Building Authority; thence running
- N 89°36'39" W 226.38 feet to a corner; thence running
- S 05°01'39" E 313.79 feet to a corner; thence running
- N 89°25'53" W 551.88 feet to a corner; thence running
- N 01°31'08" W 836.64 feet bounded westerly by land now or formerly of the Roman Catholic Bishop of Providence to a corner marked by an iron rod; thence running
- N 75°04'02" E 98.89 feet to a corner; thence running
- N 14°11'47" E 743.53 feet to a corner; thence running
- N 71°47'00" E 97.00 feet to a corner; thence running
- S 58°36'23" E 152.95 feet to a corner marked by an iron rod; thence running
- N 30°08'21" E 105.54 feet to a corner to the POINT OF BEGINNING.

The above described tract of land contains an area of 1,288,756 square feet or (29.586 acres), more or less.

FOR REFERENCE ONLY:

612 Academy Avenue  
Providence, Rhode Island

Assessor's Plat 83, Lot 276

**EXHIBIT B**

1. Easement from La Salle Academy to the City of Providence recorded in Book 718 at Page 30.
2. Notice to Dispute by La Salle Academy recorded in Book 744 at Page 296.
3. Notice of Violation by the Rhode Island Department of Environmental Management recorded in Book 2331 at Page 159.
4. Letter from the Rhode Island Department of Environmental Management recorded in Book 2636 at Page 190.
5. Order of Approval by the Rhode Island Department of Environmental Management recorded in Book 2679 at Page 89.
6. Memorandum of Lease Agreement by and between La Salle Academy ("Landlord") and Sprint Spectrum L.P. ("Tenant") recorded in Book 4445 at Page 137.
7. Insignificant Alteration – Permit issued by the Rhode Island Department of Environmental Management recorded in Book 4519 at Page 300.
8. Resolution No. 8486 by the Providence Zoning Board of Review recorded in Book 4711 at Page 119.
9. Insignificant Alteration Permit issued by the Rhode Island Department of Environmental Management and recorded in Book 5359 at Page 110.
10. Utility, Grant of Easement from La Salle Academy to the Narragansett Electric Company recorded in Book 6185 at Page 291.
11. Utility, Grant of Easement from La Salle Academy to the Narragansett Electric Company recorded in Book 6912 at Page 105.
12. Resolution No. 9501 by the Providence Zoning Board of Review recorded in Book 9716 at Page 332.
13. All matters, conditions and notes set forth on that certain plan entitled, "BOUNDARY PLAN "LASALLE ACADEMY" 612 ACADEMY AVENUE, PROVIDENCE R.I. ASSESSORS MAP 83 LOT 276 PREPARED FOR: LASALLE ACADEMY 612 ACADEMY AVENUE, PROVIDENCE R.I. JOB #18-012 SCALE: 1"=100' DRAWN BY: SCA DATE: 05/15/2018", prepared by InSite Engineering Services, LLC.

14. Rights of existing parties in possession under unrecorded leases and/or month to month tenancies.

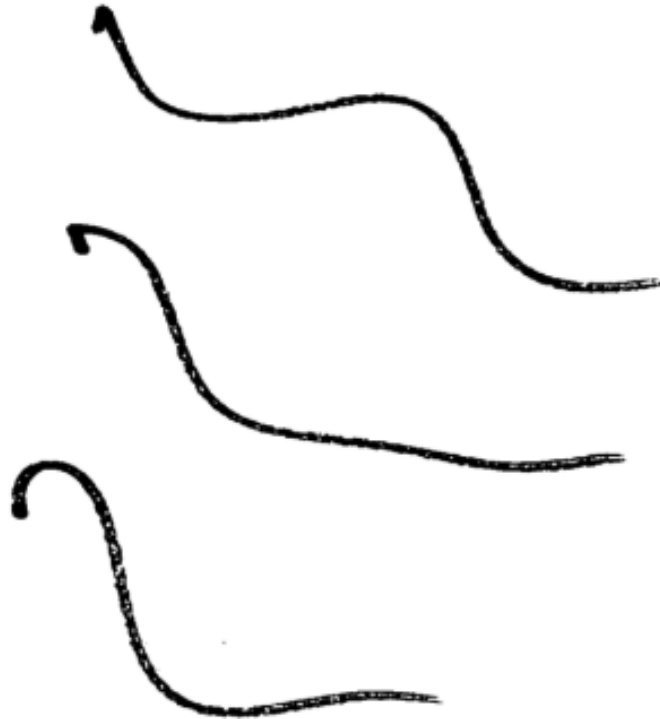

RECEIVED:

Providence  
Received for Record  
Oct 19, 2018 at 01:29P  
Document Num: 00212227  
John A Murphy  
Recorder of Deeds