

PROJECT REVIEW

1. CASE 21.099, 35 SHELDON STREET, Charles A. Lake House, 1870s (COLLEGE HILL)

Vernacular Italianate. 2½ story, clapboarded, mansard-roof house, three-bays wide with a center entry under a heavy hood on brackets with a bracketed cornice.

CONTRIBUTING

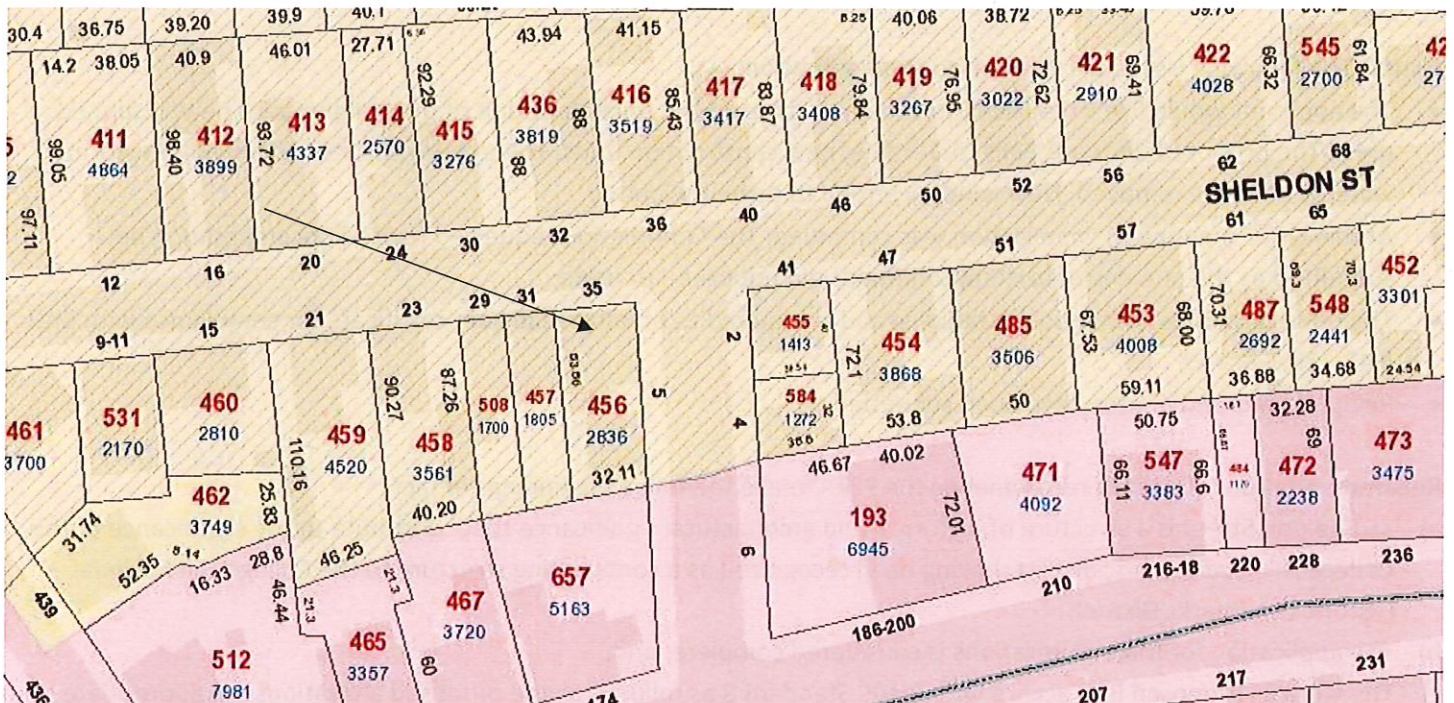

Arrow indicates 35 Sheldon Street.

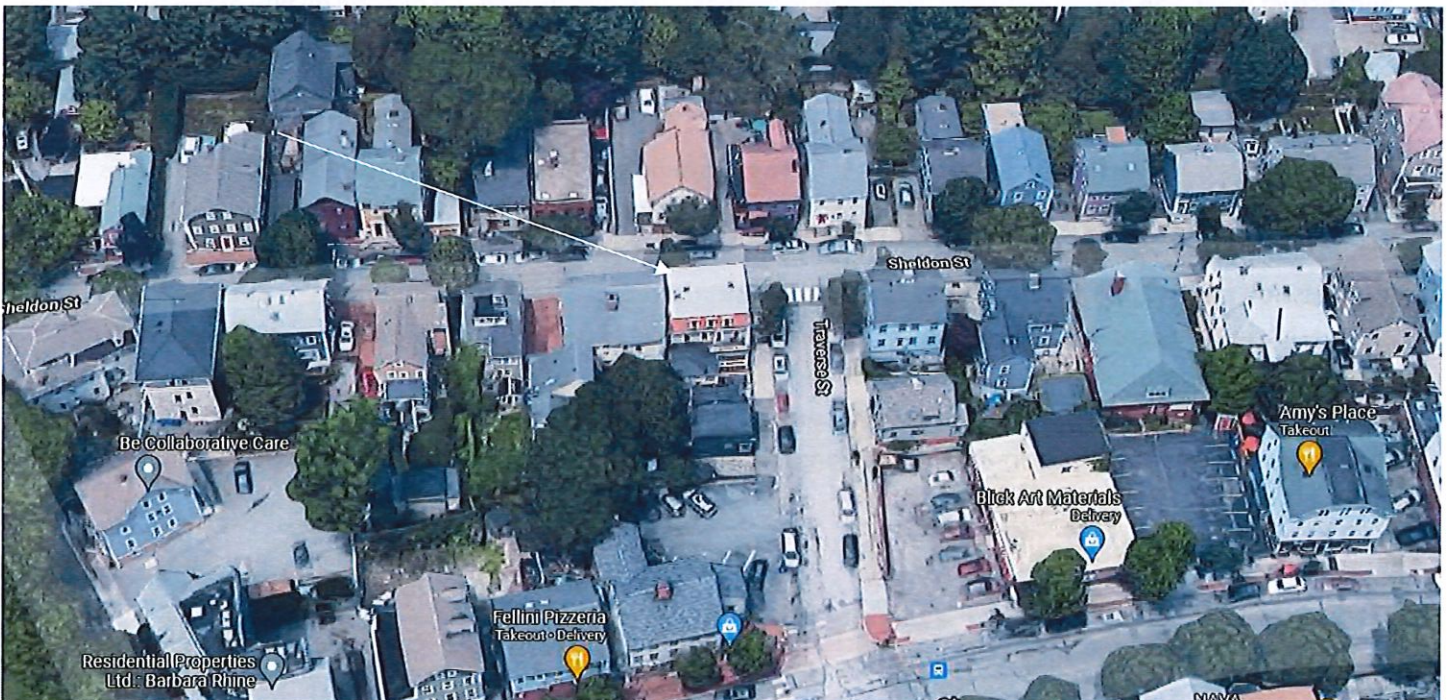

Arrow indicates project location, looking north.

Applicant/Owner: Ian Foraker, 1969 A Pine St., San Francisco, CA 94109

Contractor: Pella Windows, 20 Commerce Way Suite 11, Seekonk, MA 02771

Proposal: The scope of work proposed consists of Major Alterations and includes:

- the installation of 10 insulated replacement windows to the third floor of the mansard roof.

Issues: The following issues are relevant to this application:

- The applicant would like to replace the window sashes on the third-floor unit of the building with new, insulated units. The proposed units are Pella, full-frame, new construction units. The existing sashes and aluminum storm windows shall be removed. New window screen to be half-window;
- At the 11/22 meeting the application was continued. The Commission requested revised documentation be submitted as the drawing of existing conditions did not seem accurate;
- The house is a multi-family condo building and is required to obtain a lead-safe certificate for compliance with RIGL § 42-128.1-8; and,
- Revised plans and photos have been submitted.

Recommendations: The staff recommends the PHDC make the following findings of fact:

- a) 35 Sheldon Street is a structure of historical and architectural significance that contribute to the significance of the College Hill local historic district, having been recognized as a contributing structure to the College Hill National Historic Landmarks District;
- b) The application for Major Alterations is considered complete; and,
- c) The work as proposed is in accord with PHDC Standard 8 as follows: as the proposed alterations are appropriate having determined that the proposed construction is architecturally and historically compatible with the property and district having an appropriate size, scale and form that while diminishing the historic quality of the property will not have an adverse effect on the property or district and allows the property to come into compliance with RIGL § 42-128.1-8.

Staff recommends a motion be made stating that: The application is considered complete. 35 Sheldon Street is a structure of historical and architectural significance that contribute to the significance of the College Hill local historic district, having been recognized as a contributing structure to the College Hill National Historic Landmarks District. The Commission grants Final Approval of the proposal as submitted having determined that the proposed alterations are appropriate as the proposed alterations are architecturally and historically compatible with the property and district having an appropriate size, scale and form that while diminishing the historic quality of the property will not have an adverse effect on the property or district and allows the property to come into compliance with RIGL § 42-128.1-8, citing and agreeing to the recommendations in the staff report, with staff to review any additional required details.

EXISTING

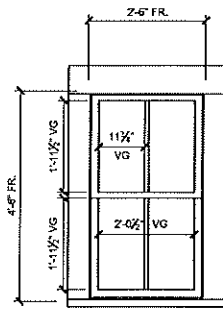

PROPOSED

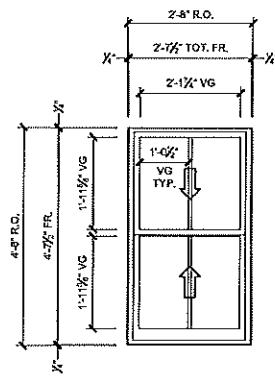

Kitchen 2
LINE # 10 QTY

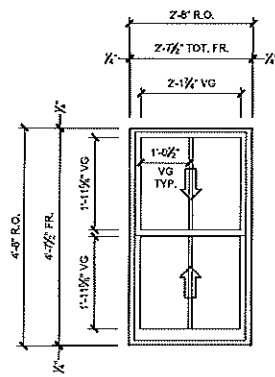

Living Room 2
LINE # 15 QTY

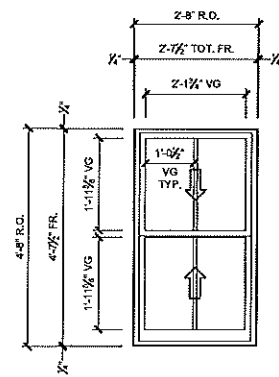

Bedroom 2
LINE # 20 QTY

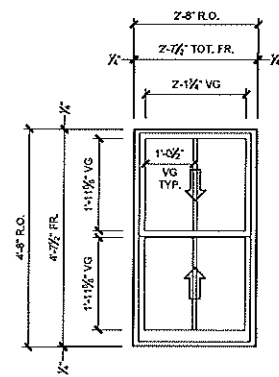

Closet 1
LINE # 25 QTY

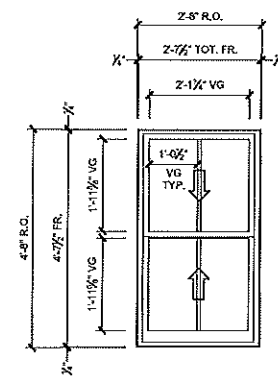

Office 2
LINE # 30 QTY

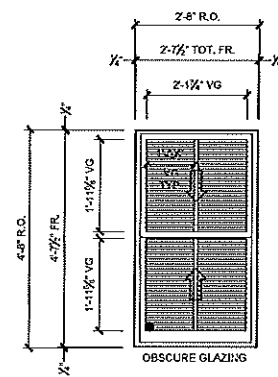

Bathroom 1
LINE # 35 QTY

| REV. | DATE | REV. | DATE |
|------|------------|------|------|
| △ | 12-15-2021 | △ | |
| △ | | △ | |
| △ | | △ | |
| △ | | △ | |
| △ | | △ | |
| △ | | △ | |

PRELIMINARY DRAWING FOR
85 Power St.
LOCATION: PROVIDENCE, RI
ARCHITECT: —

ORIGINAL: 6-05-21
DRAWN BY: TJT
Project No.:
14349128
SHEET:
1 OF 2

EXISTING

INTERIOR
EXTERIOR

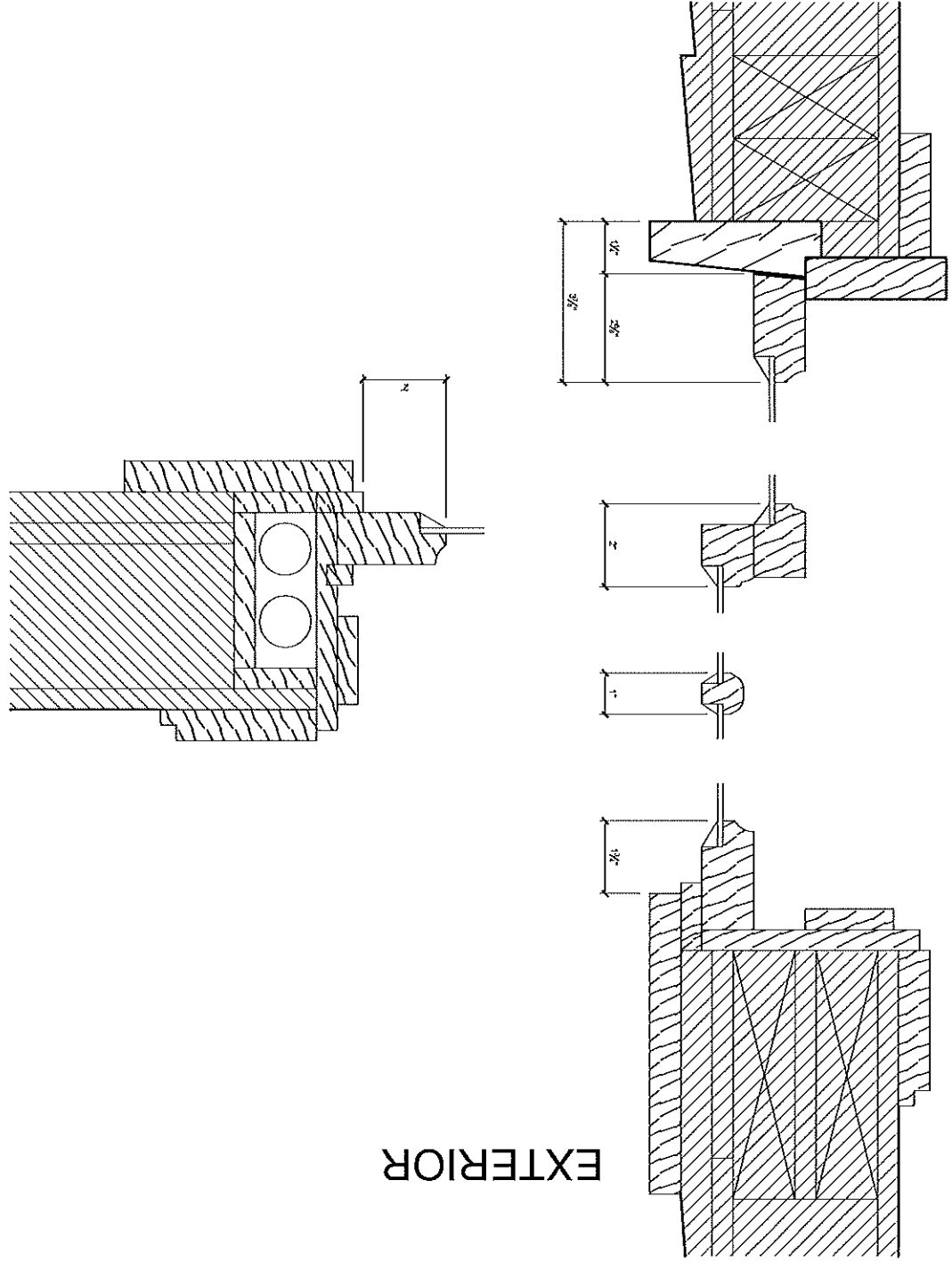

PROPOSED

INTERIOR

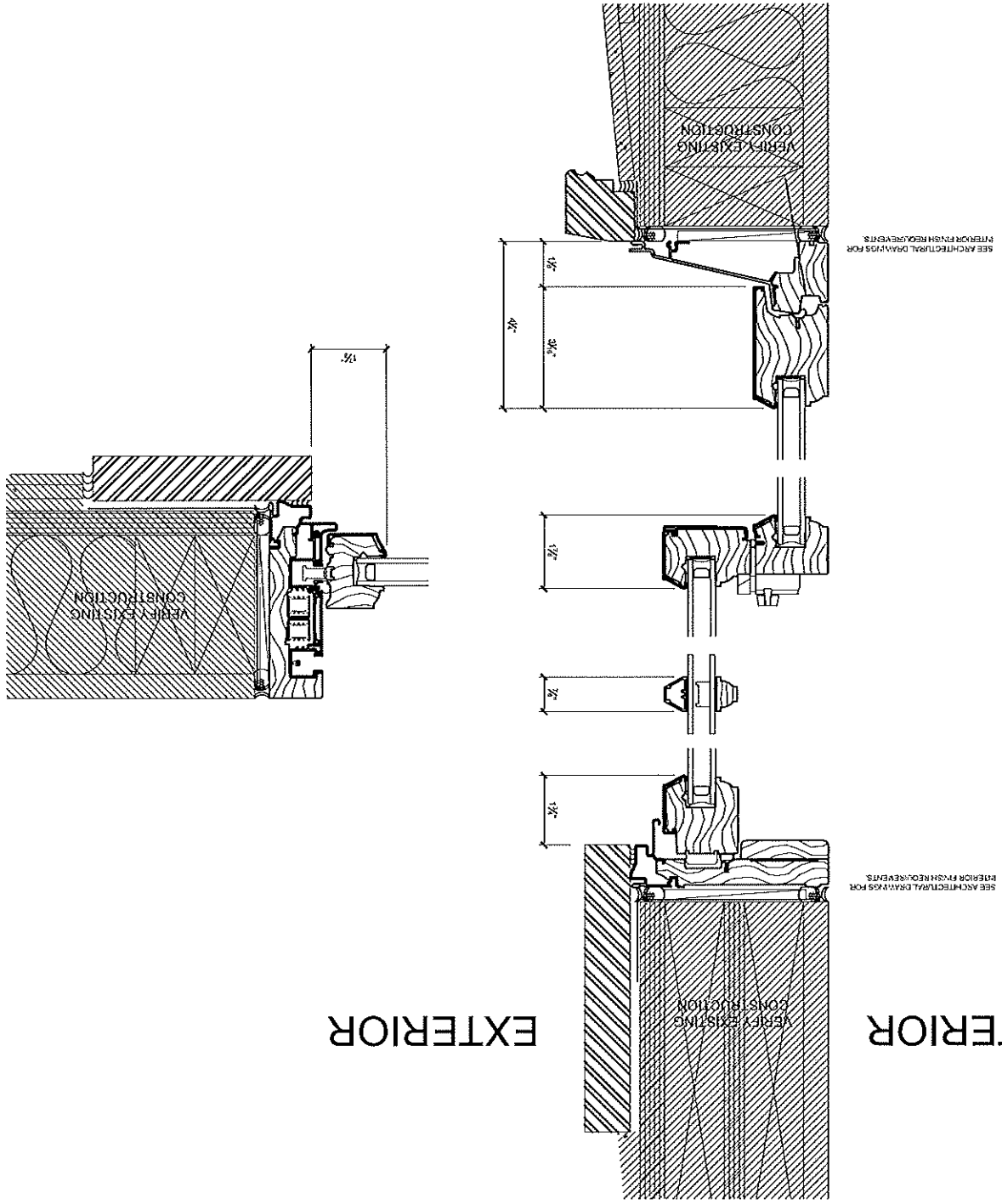

EXTERIOR

| REV. | DATE | REV. | DATE |
|------|------------|------|------|
| △ | 12/15/2021 | △ | - |
| △ | - | △ | - |
| △ | - | △ | - |
| △ | - | △ | - |
| △ | - | △ | - |
| △ | - | △ | - |



Pella
Architectural
Solutions

PRELIMINARY DRAWING FOR
35 Sheldon St.
LOCATION: Providence, RI
ARCHITECT: —

CR22CAL 082521
DRAWN BY: TJI
Project No.: 14349128
SHEET 2 OF 2

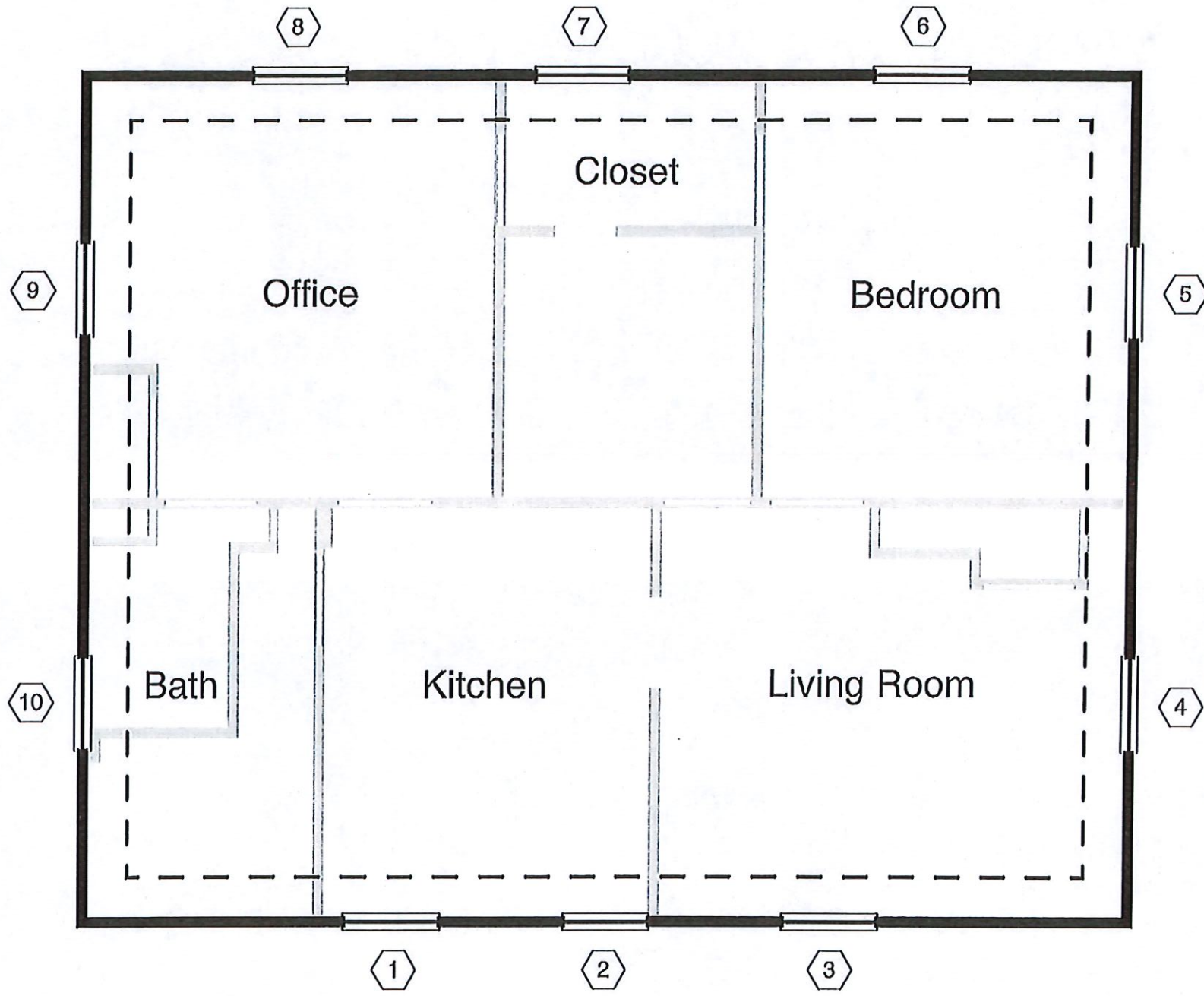

1/2" = 1'

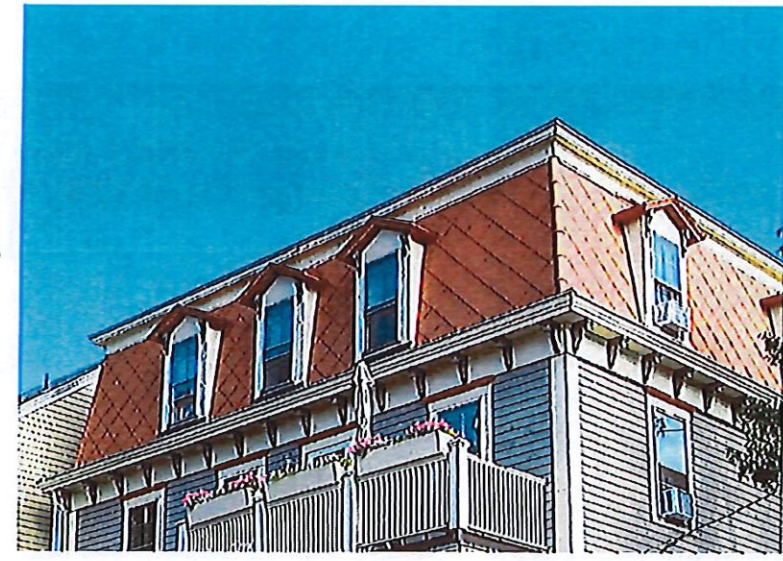

Existing View SW

| REV | DATE | BY | DATE |
|-----|------|----|------|
| 1 | | | |
| 2 | | | |
| 3 | | | |
| 4 | | | |
| 5 | | | |
| 6 | | | |
| 7 | | | |
| 8 | | | |
| 9 | | | |
| 10 | | | |

PRELIMINARY DRAWING FOR
 35 Sheldon St.
 LOCATION: Providence, RI
 ARCHITECT: —
 Project No: 14200496
 SHEET: 3 of 5

6



7



8

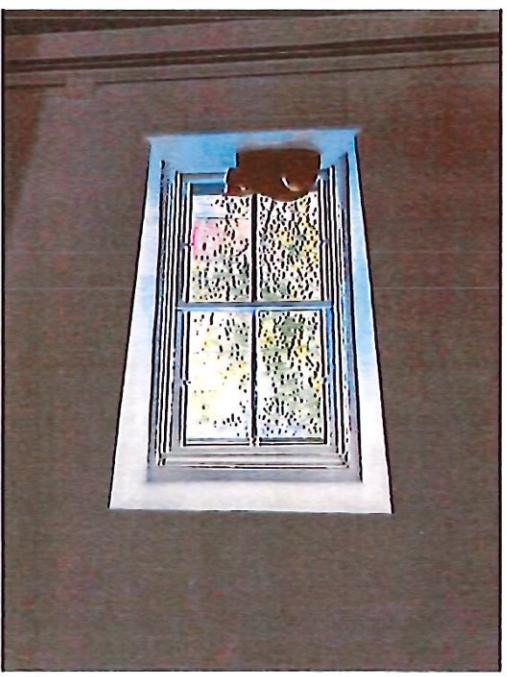

9



10



5

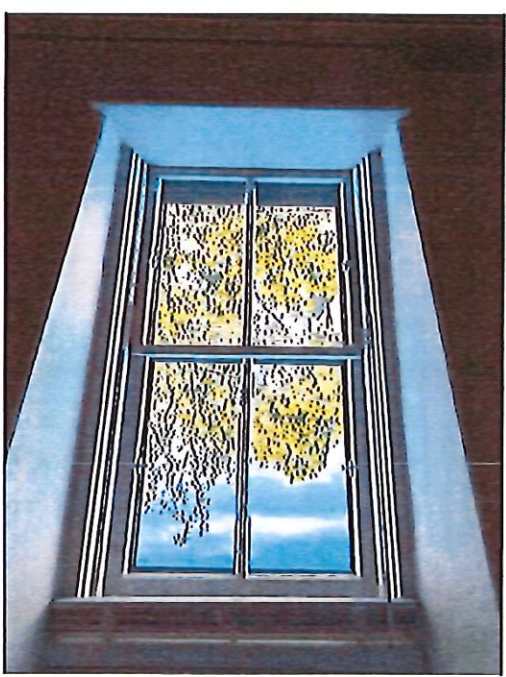

4



3

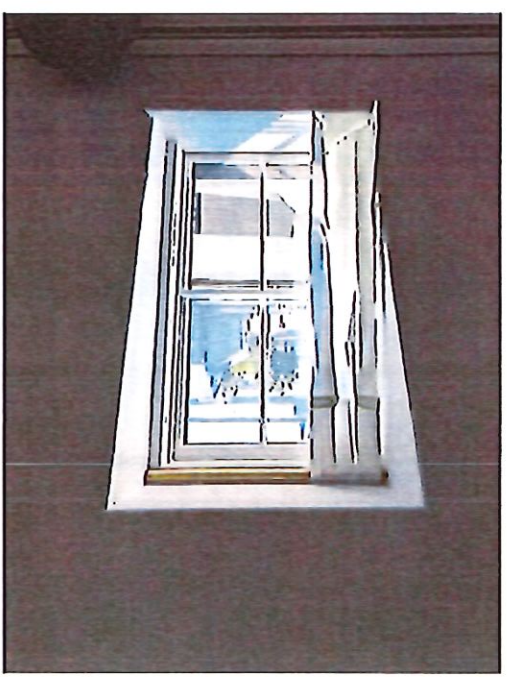

2



1



4 of 5

14208496

PRELIMINARY DRAWING FOR
35 Sheldon St
LOCATION: Providence, RI
ARCHITECT: —

| REV | DATE | BY | CHKD |
|-----|------|----|------|
| | | | |
| | | | |
| | | | |
| | | | |
| | | | |
| | | | |
| | | | |
| | | | |
| | | | |
| | | | |



Pella Architectural Solutions

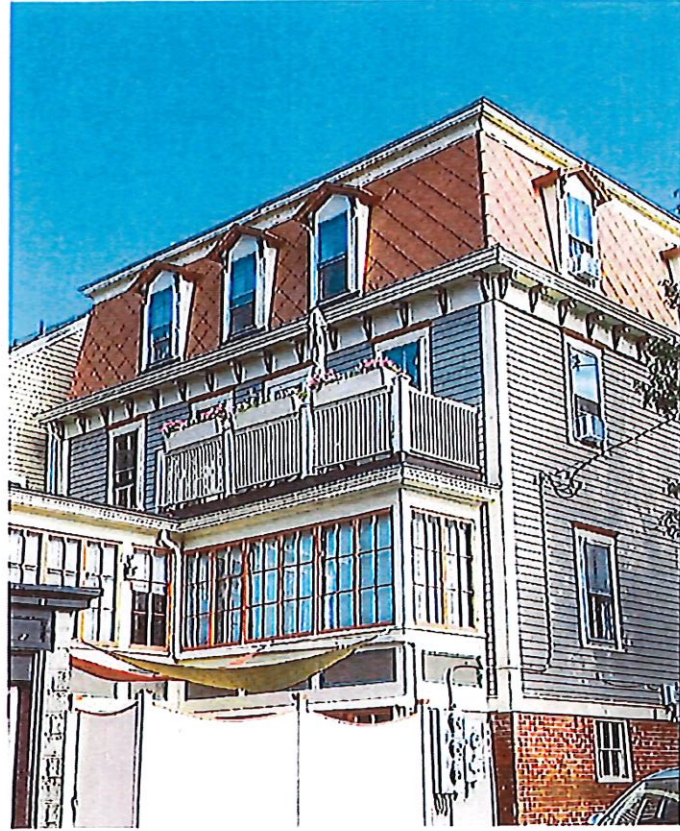

Existing View Traverse Street

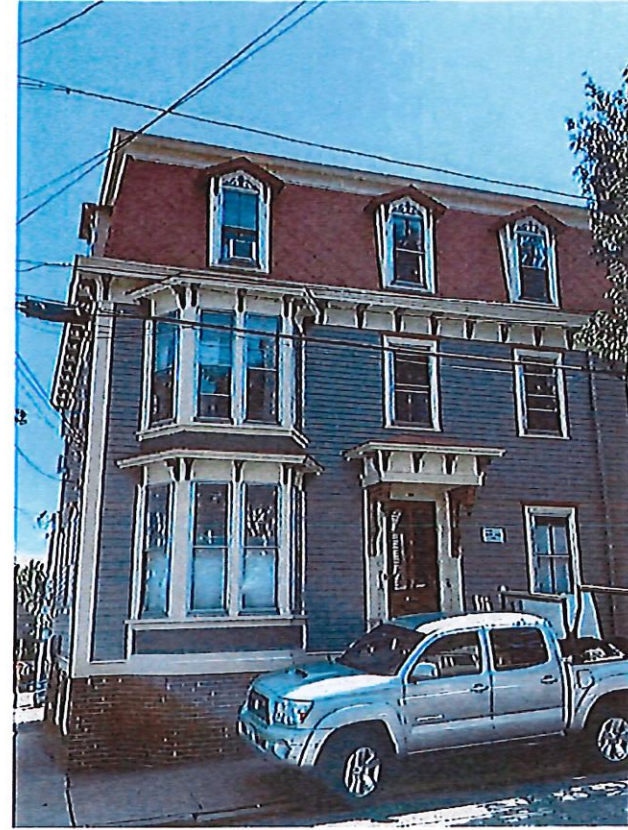
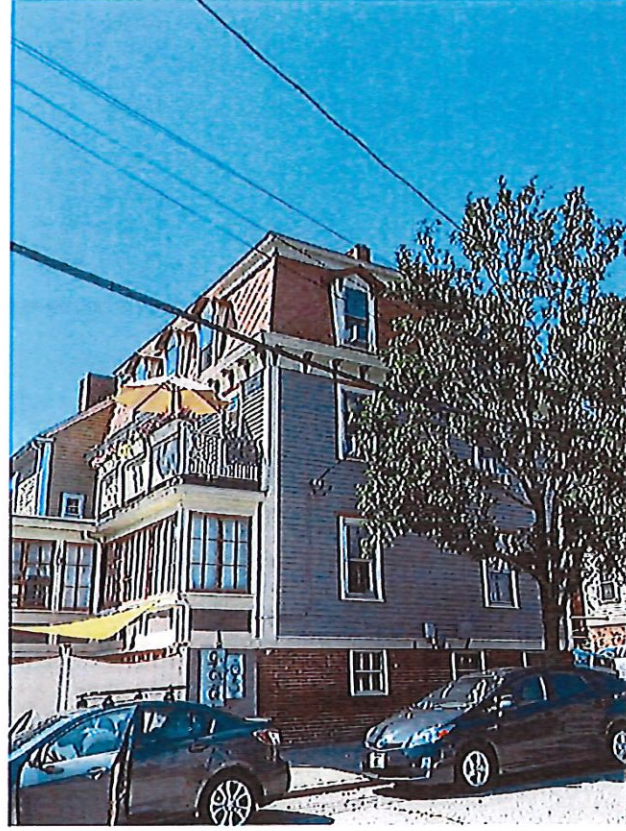

Existing View Sheldon Street

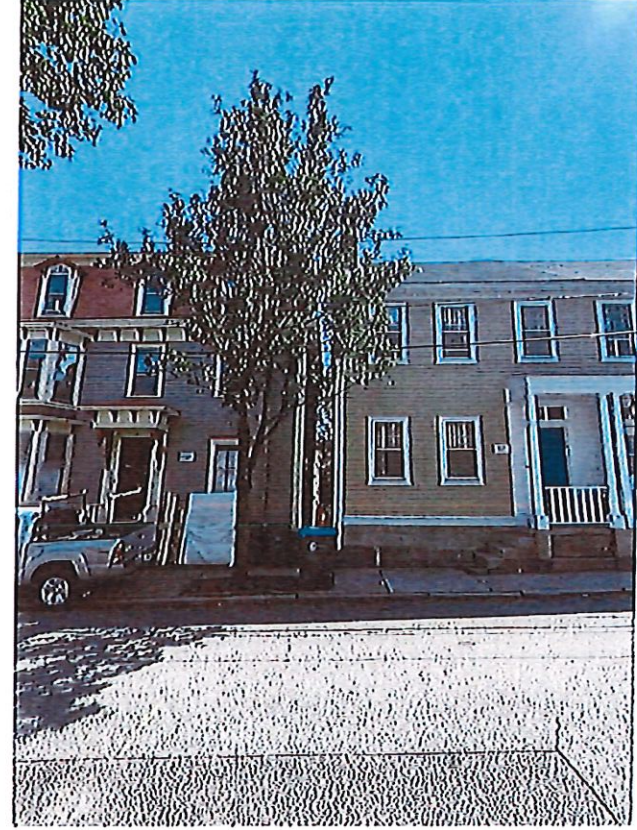

| | | | |
|------|------|----|-------|
| REV. | DATE | BY | CHKD. |
| 1 | | | |
| 2 | | | |
| 3 | | | |
| 4 | | | |
| 5 | | | |