



BOARD OF CONTRACT AND SUPPLY
CITY OF PROVIDENCE, RHODE ISLAND

REQUEST FOR PROPOSALS

Item Description: MLK Playground Phase II - Fencing

Date to be opened: July 5, 2022

Issuing Department: Public Property

QUESTIONS

- Please direct questions relative to the bidding process, how to fill out forms, and how to submit a bid (Pages 1-8) to Purchasing Agent Patti Jordan.
 - Phone: (401) 680-5264
 - Email: pjordan@providenceri.gov
 - Please use the subject line “**RFP Question**”
- Please direct questions relative to the Minority and Women’s Business Enterprise Program and the corresponding forms (Pages 9-13) to the MBE/WBE Outreach Director for the City of Providence, Grace Diaz
 - Phone: (401) 680-5766
 - Email: gdiaz@providenceri.gov
 - Please use subject line “**MBE WBE Forms**”
- Please direct questions relative to the specifications outlined (beginning on page 14) to the issuing department’s subject matter expert:
 - Ben Lobaugh, Capital Improvement Project Manager
 - blobaugh@providenceri.gov

Pre-bid Conference

Non-mandatory pre-bid conference on June 29, 2022 at 10:00am at 176 Howell St Providence, RI 02906.



**BOARD OF CONTRACT AND SUPPLY
CITY OF PROVIDENCE, RHODE ISLAND**

INSTRUCTIONS FOR SUBMISSION

Bids may be submitted up to **2:15 P.M.** on the above meeting date at the **Department of the City Clerk, Room 311, City Hall, 25 Dorrance Street, Providence.** At 2:15 P.M. all bids will be publicly opened and read at the Board of Contract Meeting in the City Council Chambers, on the 3rd floor of City Hall.

- Bidders must submit **2 copies** of their bid in sealed envelopes or packages labeled with the captioned **Item Description** and the **City Department to which the RFP and bid are related and must include the company name and address on the envelope as well.** (On page 1).
- If required by the Department, please keep the original bid bond and check in only one of the envelopes.
- Communications to the Board of Contract and Supply that are not competitive sealed bids (i.e. product information/samples) should have “**NOT A BID**” written on the envelope or wrapper.
- Only use form versions and templates included in this RFP. If you have an old version of a form do not recycle it for use in this bid.
- The bid envelope and information relative to the bid must be addressed to:

**Board of Contract and Supply
Department of the City Clerk – City Hall, Room 311
25 Dorrance Street
Providence, RI 02903**

****PLEASE NOTE:** This bid may include details regarding information that you will need to provide (such as proof of licenses) to the issuing department before the formalization of an award.

This information is NOT requested to be provided in your initial bid by design.

All bids submitted to the City Clerk become public record. Failure to follow instructions could result in information considered private being posted to the city’s Open Meetings Portal and made available as a public record. The City has made a conscious effort to avoid the posting of sensitive information on the City’s Open Meetings Portal, by requesting that such sensitive information be submitted to the issuing department only at their request.



**BOARD OF CONTRACT AND SUPPLY
CITY OF PROVIDENCE, RHODE ISLAND**

BID PACKAGE CHECKLIST

Digital forms are available in the City of Providence Purchasing Department Office or online at <http://www.providenceri.gov/purchasing/how-to-submit-a-bid/>

The bid package **MUST** include the following, in this order:

- Bid Form 1: Bidder's Blank as the cover page/ 1st page (*see page 6 of this document*)
- Bid Form 2: Certification of Bidder as 2nd page (*see page 7 of this document*)
- Bid Form 3: Certificate Regarding Public Records (*see page 8 of this document*)
- Forms from the Minority and Women Business Enterprise Program: Based on Bidder Category. *See forms and instructions enclosed (pages 9-13) or on: <https://www.providenceri.gov/purchasing/minority-women-owned-business-mbewbe-procurement-program/>*

***Please note: MBE/WBE forms must be completed for EVERY bid submitted and must be inclusive of ALL required signatures. Forms without all required signatures will be considered incomplete.**

- Bidder's Proposal/Packet: Formal response to the specifications outlined in this RFP, including pricing information and details related to the good(s) or service(s) being provided. Please be mindful of formatting responses as requested to ensure clarity.
- Financial Assurance, *if requested* (as indicated on page 5 of this document under "Bid Terms")

All of the above listed documents are REQUIRED. (With the exception of financial assurances, which are only required if specified on page 5.)

*****Failure to meet specified deadlines, follow specific submission instructions, or enclose all required documents with all applicable signatures will result in disqualification, or in an inability to appropriately evaluate bids.**



**BOARD OF CONTRACT AND SUPPLY
CITY OF PROVIDENCE, RHODE ISLAND**

NOTICE TO VENDORS

1. The Board of Contract and Supply will make the award to the lowest qualified and responsible bidder.
2. In determining the lowest responsible bidder, cash discounts based on preferable payment terms will not be considered.
3. Where prices are the same, the Board of Contract and Supply reserves the right to award to one bidder, or to split the award.
4. No proposal will be accepted if the bid is made in collusion with any other bidder.
5. Bids may be submitted on an “equal in quality” basis. The City reserves the right to decide equality. Bidders must indicate brand or the make being offered and submit detailed specifications if other than brand requested.
6. A bidder who is an out-of-state corporation shall qualify or register to transact business in this State, in accordance with the Rhode Island Business Corporation Act, RIGL Sec. 7-1.2-1401, et seq.
7. The Board of Contract and Supply reserves the right to reject any and all bids.
8. Competing bids may be viewed in person at the Department of the City Clerk, City Hall, Providence, immediately upon the conclusion of the formal Board of Contract and Supply meeting during which the bids were unsealed/opened. Bids may also be accessed electronically on the internet via the City’s [Open Meetings Portal](#).
9. As the City of Providence is exempt from the payment of Federal Excise Taxes and Rhode Island Sales Tax, prices quoted are not to include these taxes.
10. In case of error in the extension of prices quoted, the unit price will govern.
11. The contractor will **NOT** be permitted to: a) assign or underlet the contract, or b) assign either legally or equitably any monies or any claim thereto without the previous written consent of the City Purchasing Director.
12. Delivery dates must be shown in the bid. If no delivery date is specified, it will be assumed that an immediate delivery from stock will be made.
13. A certificate of insurance will normally be required of a successful vendor.
14. For many contracts involving construction, alteration and/or repair work, State law provisions concerning payment of prevailing wage rates apply ([RIGL Sec. 37-13-1 et seq.](#))
15. No goods should be delivered, or work started without a Purchase Order.
16. **Submit 3 copies of the bid to the City Clerk, unless the specification section of this document indicates otherwise.**
17. Bidder must certify that it does not unlawfully discriminate on the basis of race, color, national origin, gender, gender identity or expression, sexual orientation and/or religion in its business and hiring practices and that all of its employees are lawfully employed under all applicable federal, state and local laws, rules and regulations. (See Bid Form 2.)



BOARD OF CONTRACT AND SUPPLY
CITY OF PROVIDENCE, RHODE ISLAND

BID TERMS

1. Financial assurances may be required in order to be a successful bidder for Commodity or Construction and Service contracts. If either of the first two checkboxes below is checked, the specified assurance must accompany a bid, or the bid will not be considered by the Board of Contract and Supply. The third checkbox indicates the lowest responsible bidder will be contacted and required to post a bond to be awarded the contract.
 - a) A certified check for \$_____ must be deposited with the City Clerk as a guarantee that the Contract will be signed and delivered by the bidder.
 - b) A bid bond in the amount of _____ per centum (%) of the proposed total price, must be deposited with the City Clerk as a guarantee that the contract will be signed and delivered by the bidder; and the amount of such bid bond shall be retained for the use of the City as liquidated damages in case of default.
 - c) A performance and payment bond with a satisfactory surety company will be posted by the bidder in a sum equal to one hundred per centum (100%) of the awarded contract.
 - d) No financial assurance is necessary for this item.
2. Awards will be made within **sixty (60) days of bid opening**. All bid prices will be considered firm, unless qualified otherwise. Requests for price increases will not be honored.
3. Failure to deliver within the time quoted or failure to meet specifications may result in default in accordance with the general specifications. It is agreed that deliveries and/or completion are subject to strikes, lockouts, accidents and Acts of God.

The following entry applies only for COMMODITY BID TERMS:

4. Payment for partial delivery will not be allowed except when provided for in blanket or term contracts.

The following entries apply only for CONSTRUCTION AND SERVICE BID TERMS:

5. Only one shipping charge will be applied in the event of partial deliveries for blanket or term contracts.
6. Prior to commencing performance under the contract, the successful bidder shall attest to compliance with the provisions of the Rhode Island Worker's Compensation Act, RIGL 28-29-1, et seq. If exempt from compliance, the successful bidder shall submit a sworn Affidavit by a corporate officer to that effect, which shall accompany the signed contract.
7. Prior to commencing performance under the contract, the successful bidder shall, submit a certificate of insurance, in a form and in an amount satisfactory to the City.



**BOARD OF CONTRACT AND SUPPLY
CITY OF PROVIDENCE, RHODE ISLAND**

BID FORM 1: Bidders Blank

1. Bids must meet the attached specifications. Any exceptions or modifications must be noted and fully explained.
2. Bidder's responses must be in ink or typewritten, and all blanks on the bid form should be completed.
3. The price or prices proposed should be stated both in **WRITING** and in **FIGURES**, and any proposal not so stated may be rejected. **Contracts exceeding twelve months must specify annual costs for each year.**
4. Bids **SHOULD BE TOTALED** so that the final cost is clearly stated (unless submitting a unit price bid), however **each item should be priced individually**. Do not group items. Awards may be made on the basis of *total* bid or by *individual items*.
5. All bids **MUST BE SIGNED IN INK.**

Name of Bidder (Firm or Individual): _____

Contact Name: _____

Business Address: _____

Business Phone #: _____

Contact Email Address: _____

Agrees to bid on (Write the "Item Description" here): _____

If the bidder's company is based in a state *other than Rhode Island*, list name and contact information for a local agent for service of process that *is located within Rhode Island* _____

Delivery Date (if applicable): _____

Name of Surety Company (if applicable): _____

Total Amount in Writing*: _____

Total Amount in Figures*: _____

**** If you are submitting a unit price bid, please insert "Unit Price Bid"***

Use additional pages if necessary for additional bidding details.

Signature of Representation

Title



**BOARD OF CONTRACT AND SUPPLY
CITY OF PROVIDENCE, RHODE ISLAND**

**BID FORM 2: Certification of Bidder
(Non-Discrimination/Hiring)**

Upon behalf of _____ (Firm or Individual Bidding),

I, _____ (Name of Person Making Certification),

being its _____ (Title or "Self"), hereby certify that:

1. Bidder does not unlawfully discriminate on the basis of race, color, national origin, gender, sexual orientation and/or religion in its business and hiring practices.
2. All of Bidder's employees have been hired in compliance with all applicable federal, state and local laws, rules and regulations.

I affirm by signing below that I am duly authorized on behalf of Bidder, on

this _____ day of _____ 20_____.

Signature of Representation

Printed Name



**BOARD OF CONTRACT AND SUPPLY
CITY OF PROVIDENCE, RHODE ISLAND**

BID FORM 3: Certificate Regarding Public Records

Upon behalf of _____ (Firm or Individual Bidding),

I, _____ (Name of Person Making Certification),

being its _____ (Title or "Self"), hereby certify an

understanding that:

1. All bids submitted in response to Requests for Proposals (RFP's) and Requests for Qualification (RFQ's), documents contained within, and the details outlined on those documents become public record upon receipt by the City Clerk's office and opening at the corresponding Board of Contract and Supply (BOCS) meeting.
2. The Purchasing Department and the issuing department for this RFP/RFQ have made a conscious effort to request that sensitive/personal information be submitted directly to the issuing department and only at request if verification of specific details is critical the evaluation of a vendor's bid.
3. The requested supplemental information may be crucial to evaluating bids. Failure to provide such details may result in disqualification, or an inability to appropriately evaluate bids.
4. If sensitive information that has not been requested is enclosed or if a bidder opts to enclose the defined supplemental information prior to the issuing department's request in the bidding packet submitted to the City Clerk, the City of Providence has no obligation to redact those details and bears no liability associated with the information becoming public record.
5. The City of Providence observes a public and transparent bidding process. Information required in the bidding packet may not be submitted directly to the issuing department at the discretion of the bidder in order to protect other information, such as pricing terms, from becoming public. Bidders who make such an attempt will be disqualified.

I affirm by signing below that I am duly authorized on behalf of Bidder, on

this _____ day of _____ 20____.

Signature of Representation

Printed Name



**BOARD OF CONTRACT AND SUPPLY
CITY OF PROVIDENCE, RHODE ISLAND**

WBE/MBE Form Instructions

The City of Providence actively seeks Minority and Women business enterprises to participate in bids to meet the City's procurement needs. Pursuant to the City of Providence Code of Ordinances, Chapter 21, Article II, Sec. 21-52 (Minority and Women's Business Enterprise) and Rhode Island General Laws (as amended), Chapter 31-14, et seq. (Minority Business Enterprise), Minority Business Enterprise (MBE) and Women's Business Enterprise (WBE) participation goals apply to contracts.

The goal for Minority Business Enterprise (MBE) participation is **10%** of the total bid value.

The goal for Women's Business Enterprise (WBE) participation is **10%** of the total bid value.

The goal for combined MBE/WBE participation is **20%** of the total bid value.

Only businesses certified with the State of Rhode Island as minority and/or women business enterprises are counted towards the City's goals. Eligible minority or women-owned businesses are encouraged to seek certification from the State of Rhode Island Minority Business Enterprise Compliance Office at: <http://odeo.ri.gov/offices/mbeco/>

Note: MBE certification with the State of Rhode Island on the basis of Portuguese heritage is not currently recognized by the City of Providence's MBE program.

Bid Requirements:

All Bidders: All bidders **must complete and submit the *MBE/WBE Participation Affidavit*** indicating whether or not they are a state-certified MBE/WBE and acknowledging the City's participation goals. Submission of this form is **required with every bid**. **Your bid will not be accepted without an affidavit.**

Bidders who will be subcontracting: *In addition to the MBE/WBE Participation Affidavit*, Bidders who will be subcontracting must submit the *Subcontractor Disclosure Form* as part of their bid submission. All subcontractors, regardless of MBE/WBE status, must be listed on this form. Business NAICS codes can be found at <https://www.naics.com/search/>. Awarded bidders are required to submit

Subcontractor Utilization and Payment Reports with each invoice.

Waiver Requests:

- a) If the percentage of the total amount of the bid being awarded to MBE or WBE vendors is less than 20% (Box F on the Subcontractor Disclosure Form) and the prime contractor is not a Rhode Island State-certified MBE or WBE, the Bidder must complete the *MBE/WBE Waiver Request Form* for review.
- b) If the prime contractor company has the capacity to perform the whole project, the City of Providence requires the contractor to meet the city's goal of a combined 20% of MBE and WBE participation.
- c) If the contractor is a nonprofit organization, the City of Providence requires the nonprofit organization to provide the *MBE/WBE Participation Affidavit Form* and proof of its nonprofit status.
- d) If the contractor has researched the RI Certified minority list (<http://odeo.ri.gov/offices/mbeco/mbe-wbe.php>) and the state does not have any companies in the desired trade, the City of Providence requires the contractor to provide the *MBE/WBE Participation Affidavit Form*.
- e) Waivers will be considered for approval on a case-by-case basis.



**BOARD OF CONTRACT AND SUPPLY
CITY OF PROVIDENCE, RHODE ISLAND**

Verifying MBE/WBE Certification

It is the responsibility of the bidder to confirm that every MBE or WBE named in a proposal and included on a contract is certified by the Rhode Island Minority Business Enterprise Compliance Office. The current MBE/WBE directory is available at the State of RI MBE Office, One Capitol Hill, 2nd Floor, Providence, RI, or online at <http://odeo.ri.gov/offices/mbeco/mbe-wbe.php>. You can also call (401) 574-8670 to verify certification, expiration dates, and services that the MBE/WBE is certified to provide. Note: MBE certification with the State of Rhode Island on the basis of Portuguese heritage is not currently recognized by the City of Providence's MBE program.

Form Instructions:

Access all bid forms from <http://www.providenceri.gov/oeo/> or <http://www.providenceri.gov/purchasing/minority-women-owned-business-mbewbe-procurement-program/>. Download the forms as blank PDFs. Once saved on your computer, fill them out using the Adobe program. The fillable PDFs must be completed in Adobe in order to be saved properly. Google Chrome and similar platforms do not allow for the forms to be saved as filled PDFs. Therefore, please download the blank forms to your computer, then fill them out and save.

Assistance with Form Requirements

Examples of completed forms can be found on the City of Providence website at <http://www.providenceri.gov/oeo/> or <http://www.providenceri.gov/purchasing/minority-women-owned-business-mbewbe-procurement-program/>.

Contract Requirements:

Prime contractors engaging subcontractors must submit the *Subcontractor Utilization and Payment Report* to the City Department's Fiscal Agent with every invoice and request for final payment. A copy of all forms should be sent to the MBE/WBE Outreach Director Office, Grace Diaz at gdiaz@providenceri.gov. This form is not submitted as a part of the initial bid package.

For contracts with durations of less than 3 months, this form must be submitted along with the contractor's request for final payment. The form must include all subcontractors utilized on the contract, both MBE/WBE and non- MBE/WBE, the total amount paid to each subcontractor for the given period and to date. A copy of all forms should be sent to the MBE/WBE Outreach Director Office, Grace Diaz at gdiaz@providenceri.gov. During the term of the contract, any unjustified failure to comply with the MBE/WBE participation requirements is a material breach of contract.

Questions?

For more information or for assistance with MBE/WBE Forms, contact the City of Providence MBE/WBE Outreach Director, Grace Diaz, at gdiaz@providenceri.gov or (401) 680-5766.



**BOARD OF CONTRACT AND SUPPLY
CITY OF PROVIDENCE, RHODE ISLAND**

MBE/WBE PARTICIPATION AFFIDAVIT

Project /Item Description (as seen on RFP):

Prime Bidder: _____ Contact Email and Phone _____

Company Name, Address and Trade: _____

Which one of the following describes your business' status in terms of Minority and/or Woman-Owned Business Enterprise certification with the State of Rhode Island? MBE WBE Neither MBE nor WBE

By initialing the following sections and signing the bottom of this document in my capacity as the contractor or an authorized representative of contractor, I make this Affidavit:

It is the policy of the City of Providence that minority business enterprises (MBEs) and women business enterprises (WBEs) should have the maximum opportunity to participate in procurements and projects as prime contractors and vendors. Pursuant to Sec. 21-52 of the Providence Code of Ordinances and Chapter 31-14 *et seq.* of the Rhode Island General Laws (as amended), MBE and WBE participation goals apply to contracts.

The goal for Minority Business Enterprise (MBE) participation is 10% of the total bid value.
The goal for Women's Business Enterprise (WBE) participation is 10% of the total bid value.
The goal for combined MBE/WBE participation is 20% of the total bid value.

I acknowledge the City of Providence's goals of supporting MBE/WBE certified businesses. Initial _____

If awarded the contract, I understand that my company must submit to the Minority and Women's Business Coordinator at the City of Providence (MBE/WBE Office), copies of all executed agreements with the subcontractor(s) being utilized to achieve the participation goals and other requirements of the RI General Laws. **I understand that these documents must be submitted prior to the issuance of a notice to proceed.** Initial _____

I understand that, if awarded the contract, my firm must submit to the MBE/WBE Office canceled checks and reports required by the MBE/WBE Office on a quarterly basis verifying payments to the subcontractors(s) utilized on the contract.
Initial _____

If I am awarded this contract and find that I am unable to utilize the subcontractor(s) identified in my Statement of Intent, I understand that I must substitute another certified MBE and WBE firm(s) to meet the participation goals. **I understand that I may not make a substitution until I have obtained the written approval of the MBE/WBE Office.**
Initial _____

If awarded this contract, I understand that authorized representatives of the City of Providence may examine the books, records and files of my firm from time to time, to the extent that such material is relevant to a determination of whether my firm is complying with the City's MBE/WBE participation requirements.
Initial _____

I do solemnly declare and affirm under the penalty of perjury that the contents of the foregoing Affidavit are true and correct to the best of my knowledge, information, and belief.

Signature of Bidder

Printed Name

Company Name

Date



**BOARD OF CONTRACT AND SUPPLY
CITY OF PROVIDENCE, RHODE ISLAND**

SUBCONTRACTOR DISCLOSURE FORM

Fill out this form only if you WILL SUBCONTRACT with other parties. If you will not subcontract any portion of the proposed bid, do not fill out this form.

Prime Bidder: _____ Primary NAICS _____

Code: _____

Item Description (as seen on RFP): _____

Please list all Subcontractors below. Include the total dollar value that you propose to share with each subcontractor and the dollar amount to be subcontracted. Please check off MBE and WBE where applicable. The directory of all state-certified MBE/WBE firms is located at www.mbe.ri.gov. Business NAICS codes can be found at <https://www.naics.com/search/>

Proposed Subcontractor	MBE	WBE	Primary NAICS Code	Date of Mobilization	\$ Value of Subcontract
					\$
					\$
					\$
					\$
					\$
					\$
A. MBE SUBCONTRACTED AMOUNT:					\$
B. WBE SUBCONTRACTED AMOUNT:					\$
C. NON-MBE WBE SUBCONTRACTED AMOUNT:					\$
D. DOLLAR AMOUNT OF WORK DONE BY THE PRIME CONTRACTOR:					\$
E. TOTAL AMOUNT OF BID (SUM OF A, B, C, & D):					\$
F. PERCENTAGE OF BID SUBCONTRACTED TO MBEs AND WBEs. (Divide the sum of A and B by E and multiply result by 100).					%

Please read and initial the following statement acknowledging you understand. If the percentage of the total amount of the bid being awarded to MBE or WBE vendors is less than 20% (Box (F)) and the prime contractor is NOT a Rhode Island State-certified MBE or WBE, you must fill out the MBE/WBE WAIVER REQUEST FORM for consideration by City of Providence MBE/WBE Outreach Director. Initial _____ Required

Signature of Bidder

Printed Name



**BOARD OF CONTRACT AND SUPPLY
CITY OF PROVIDENCE, RHODE ISLAND**

MBE/WBE Waiver Request Form

Fill out this form only if you did not meet the 20% MBE/WBE participation goal.

State-certified MBE or WBE Prime Bidders are NOT REQUIRED to fill out this form.

Submit this form to the City of Providence MBE/WBE Outreach Director, Grace Diaz, at mbe-wbe@providenceri.gov, for review **prior to bid submission**. This waiver applies only to the current bid which you are submitting to the City of Providence and does not apply to other bids your company may submit in the future. **In case a waiver is needed, City Department Directors should not recommend a bidder for award if this form is not included, absent or is not signed by the city of Providence MBE/WBE director.**

Prime Bidder: _____ Contact Email and Phone _____

Company Name, Address: _____ Trade _____

Project /Item Description (as seen on RFP):

To receive a waiver, you must list the certified MBE and/or WBE companies you contacted, the name of the primary individual with whom you interacted, and the reason the MBE/WBE company could not participate on this project.

MBE/WBE Company Name	Individual's Name	Company Name	Why did you choose not to work with this company?

I acknowledge the City of Providence's goal of a combined MBE/WBE participation is 20% of the total bid value. I am requesting a waiver of _____ % MBE/WBE (20% minus the value of **Box F** on the Subcontractor Disclosure Form). If an opportunity is identified to subcontract any task associated with the fulfillment of this contract, a good faith effort will be made to select MBE/WBE certified businesses as partners.

Signature of Prime Contractor / or Duly Authorized Representative
Date Signed

Printed Name

Signature of City of Providence (or Designee (Only))
MBE/WBE Outreach Director

Printed Name of City of Providence
MBE/WBE Outreach Director

Date Signed



**BOARD OF CONTRACT AND SUPPLY
CITY OF PROVIDENCE, RHODE ISLAND**

Supplemental Bid Form

To whom it may concern:

1. The undersigned, having familiarized (himself) (themselves) (itself) with the **MLK PLAYGROUND PHASE II – FENCING** bid affecting the cost of work, and with the Contract Documents (which includes the Invitation for Bids, Instructions to Bidders, Form of Bid Bond, Form of Agreements, form of Non-Collusive Affidavit, Addenda (if any), Drawings, Technical Specification, Form of Surety Bond(s); as prepared by the Department of Public Property, and on file in the office of the City Clerk 3rd Floor, City Hall, Providence, RI 02903, hereby proposes to furnish all supervision, technical personnel, labor, materials, machinery, tools, equipment and services including utility and transportation services, and to perform such other required work for the **MLK PLAYGROUND PHASE II - FENCING** and such other required and incidental work, complete, all in accordance with the above listed documents and for the unit prices for work in-place for the following items and quantities.

2. In submitting this Bid, the bidder understands that the right is reserved by the Department of Public Property to reject any and all Bids, If written notice of acceptance of this Bid is mailed, telegraphed or delivered to the undersigned within (90) days after the opening thereof, or at any time thereafter before this Bid is withdrawn, the undersigned agrees to execute and deliver an Agreement in the prescribed form and furnish the required bond within (10) days after the Agreement is presented to him/her for signature.

Herewith in accordance with the instructions to Bidders.

3. Attached hereto is an affidavit in proof that the undersigned has not colluded with any person in respect to this. Bid or any bids for the Contractor for which this Bid is submitted. Also attached is a Statement of Bidder's Qualifications.

4. application unit prices are contained in the Agreement (established as the result of either a Unit Price Bid or a Supplemental Schedule of Unit Prices), the City of Providence may order the Contractor to proceed with desired changes in the work, the value of such changes to be determined by the measured quantities involved and the application unit prices specified in the Contract.

5. The City of Providence reserves the right to determine the lowest responsible Bidder based on past experience with the City and/or recommendations by City and/or state agencies with an interest in this procurement. The City reserves the right to award the project to the appropriate bidder in the best interest of the City of Providence.



**BOARD OF CONTRACT AND SUPPLY
CITY OF PROVIDENCE, RHODE ISLAND**

CERTIFICATION OF NON-SEGREGATED FACILITIES

The Bidder certifies that he/she does not maintain or provide for his/her employees any segregated facilities at any of his establishments, and that he/she does not permit his/her employees to perform their services at any location, under his/her control, where segregation facilities are maintained. The Bidder agrees that a breach of this certification will be a violation of the Equal Opportunity Clause in any contract resulting from acceptance of this Bid. As used in this certification, term "segregation facilities" means any waiting rooms, work rooms, rest rooms and wash rooms, restaurants and other eating areas, time clocks, locker rooms and other storage or dressing areas, parking lots, drinking fountains, recreation or entertainment areas, transportation and housing facilities provided for employee which are segregated by explicit directive or are in fact segregated on basis of race, color, religion, or national origin, because of habit, local custom, or otherwise. The Bidder agrees that (except where he/she has obtained identical certification from proposed subcontractors for specific time periods) he/she will obtain identical certification from proposed subcontractor prior to the award of subcontracts exceeding \$10,000.00 which are not exempt from provisions of the Equal Opportunity Clause, and that he/she will retain such certifications in his/her files.

NOTE: The penalty for making false statements in offers is prescribed in 18 U.S.C. & 1001.

DATE _____, 20 ____

Name of Bidder and Official Address:

Name of Authorized Representative (Contact):

By _____
(Signature)
Title _____

E-Mail: _____

Phone: _____

**Bidder shall indicate, in space provided,
the earliest possible Project Start-up Date:** _____, 20 ____



**BOARD OF CONTRACT AND SUPPLY
CITY OF PROVIDENCE, RHODE ISLAND**

ADDENDA: The undersigned acknowledges receipt of the following Addenda, if any, and has included the provisions thereof in this Bid (If Any):

<u>Addendum No.</u>	<u>Date</u>	<u>Addendum No.</u>	<u>Date</u>
_____	_____, 20 ____	_____	_____, 20 ____
_____	_____, 20 ____	_____	_____, 20 ____

Sub-Contractors (If Any):

Name: _____ **Scope of Work:** _____ **MBE / WBE**

Name: _____ **Scope of Work:** _____ **MBE / WBE**

Name: _____ **Scope of Work:** _____ **MBE / WBE**



**BOARD OF CONTRACT AND SUPPLY
CITY OF PROVIDENCE, RHODE ISLAND**

BASE BID: MLK PLAYGROUND PHASE II - FENCING

In addition to stating the Total Base Bid, the bidder shall state Unit Prices for related work listed under each bid item which represents the work items included in the Total Base Bid. The Unit Prices are quoted for computing adjustments to the Base Bid prior to Contract award, as well as during the course of construction, based upon extra work ordered by the City or for work countermanded, reduced or omitted by the City in order to stay within the Project budget.

Base Bid Items and Unit prices are to be Completed prices to be added or deducted on the basis of quantities of work involved, for each item in place in the unit indicated.

BASE BID: The Base Bid scope of work for this project shall include, but not be limited to the following:

Demolish approximately 500 LF of existing chain link perimeter fencing at the MLK Playground located at 176 Howell St Providence, RI 02906. Replace with Patriot Ornamental Wire Fence as manufactured by Jerith Manufacturing LLC, 48" nominal fence height, black, with 2-1/2" 12-gauge square steel posts. Replace one double-gate and two standard single gates. All gates shall be securely latching. See attached drawings on standard fence design.

All Work Included in this Project Shall be Completed for the lump sum of:

_____ Dollars

(\$ _____), **TOTAL BASE BID**

ALTERNATES:

None

BIDDER: _____

Please note that the list above is not intended to include all items required to complete the base bid scope of work but can and shall be used to adjust the contract prior to or after award – in the best interest of the City of Providence.

BIDDER: _____



**BOARD OF CONTRACT AND SUPPLY
CITY OF PROVIDENCE, RHODE ISLAND**

TECHNICAL SPECIFICATIONS

Section 32 31 16 – Welded Wire Fences and Gates

PART 1 – GENERAL:

1.01 SECTION INCLUDES

A. Decorative welded wire fencing, gates, and accessories.

1.02 RELATED SECTIONS

1.03 SYSTEM DESCRIPTION

A. The manufacturer shall supply a total ornamental welded wire fence system of the style, strength, size, and color defined herein. The system shall include all components as required, and shall be fabricated, coated, and assembled in the United States.

1.04 QUALITY ASSURANCE

A. The contractor shall provide laborers and supervisors who are familiar with the type of construction involved, and the materials and techniques specified.

B. Manufacturer of fence system must have ten (10) years of documented experience in manufacturing the products specified in this section.

1.05 REFERENCES

A. ASTM A525 - Specification for General Requirements for Steel Sheet, Zinc-coated (Galvanized) by the Hot-Dip Process

B. ASTM A641 – Specification for Zinc-Coated (Galvanized) Carbon Steel Wire

C. ASTM A185 – Specification for Steel Welded Wire Fabric, Plain, for Concrete Reinforcement.

D. ASTM B117 – Practice for Operating Salt Spray (Fog) Apparatus

E. ASTM D2247 – Standard Practice for Testing Water Resistance of Coatings in 100% Relative Humidity

1.06 SUBMITTALS

A. Manufacturer's submittal package shall be provided prior to installation.

B. Changes in specification may not be made after the bid date.

C. Samples of assembled materials, components, hardware, accessories, and/or colors, if requested.



**BOARD OF CONTRACT AND SUPPLY
CITY OF PROVIDENCE, RHODE ISLAND**

1.07 PRODUCT DELIVERY, STORAGE AND HANDLING

- A. Upon receipt, materials should be checked for damage that may have occurred in shipping to the job site.
- B. Each package shall bear the name of the manufacturer.
- C. Store products in manufacturer's unopened packaging.
- D. Store materials in a secure and dry area to protect against damage, weather, vandalism, and theft.
- E. Transport, handle and store products with care to protect against damage before installation.

PART 2 – PRODUCTS:

2.01 MANUFACTURER

- A. The fencing system shall be Patriot Ornamental Wire Fence as manufactured by Jerith Manufacturing LLC., 14400 McNulty Road, Philadelphia, PA 19154. Telephone: 800-344-2242; Fax: 215-676-9756; email: sales@jerith.com.
- B. Substitutions: Not permitted
- C. Nominal fence height shall be 48 inches.
- E. Color shall be Black.

2.02 MATERIALS

- A. Structural Components: All posts and rails used in the fence system shall be manufactured from coil steel having a minimum yield strength of 55,000 psi. The steel shall be galvanized to meet the requirements of ASTM A525 with a zinc coating weight of 0.60-1.0 ounces per square foot.
- B. Infill: Section infill wires shall be steel with a minimum yield strength of 50,000 psi. The steel shall be galvanized to meet the designation of "regular coating" in accordance with requirements of ASTM A641.

2.03 FINISH

- A. Pretreatment: A five stage non-chrome pretreatment shall be applied. The final stage shall be a dry-in-place activator which produces a uniform chemical conversion coating for superior adhesion.
- B. Coating: Fence materials shall be coated with a TGIC polyester powder-coat finish system. Epoxy powder coatings, baked enamel or acrylic paint finishes are not acceptable. The finish shall have a cured film thickness of at least 2.0 mils.
- C. Tests: The cured finish shall meet the following requirements:
 - 1. Humidity resistance of 1,000 hours using ASTM D2247.
 - 2. Salt-spray resistance of 1,000 hours using ASTM B117.
 - 3. Outdoor weathering shall show no adhesion loss, checking or crazing, with only slight fade and chalk when exposed for 3 years in Florida facing south at a 45 degree angle.



**BOARD OF CONTRACT AND SUPPLY
CITY OF PROVIDENCE, RHODE ISLAND**

2.03 FABRICATION

A. Fence Sections shall be manufactured with 1" square x 18 gauge (.049") tubing welded every 12" to the top and bottom of welded wire panels. Welded wire panels shall be comprised of 4 (.225") gauge (Washburn & Moen Standard) vertical wires and 6 (.192") gauge horizontal wires. 4 gauge vertical wires shall be placed 3½" on center. Horizontal wires shall be 6 gauge and spaced to provide style differences but no further apart than would allow substantial rigidity of vertical wires. Horizontal and vertical wires shall be assembled by automatic machines or other suitable mechanical means that will ensure accurate spacing and alignment of all members of the finished fabric. The wires shall be connected at every intersection by electric resistance welding in accordance with all requirements in ASTM A185. Sections shall be capable of supporting a 550 lb. load applied vertically at midspan and a concentrated load of 225 lbs. applied horizontally at midspan without permanent deformation.

B. Posts shall be 2½" square x 12 (.105") gauge steel tubing. Posts shall be spaced 70" apart from inside face to inside face. Steel rail ends shall be screwed to terminal posts to receive the 1" square top and bottom rails. The rails shall be secured to the rail ends by stainless steel screws. Steel caps shall be provided with all posts.

C. Residential and light commercial grade gates shall be assembled using gate uprights with 1" outside cross-section dimensions having 7/8" tubes welded to them. A Fence Section shall then be cut to size and secured to two uprights using stainless steel screws. A 1" x .125" diagonal brace shall be provided, cut to length, cold galvanized, touched up, and screwed into position from the top hinge side to the bottom latch side of the gate. All gates shall support a 300 lb. vertical load on the latch side of the gate without collapsing.

D. Heavy duty grade gate frames shall consist of 2" square x .125" wall gate uprights and 1.5" x 1.5" x .125" U-channels for top and bottom members welded at each connection with a 1" x .125" wall diagonal brace welded into place. Infill of matching Fence Section shall be welded into frame.

2.05 WARRANTY

A. The entire fence system shall have a written 8 Year Warranty against rust and defects in workmanship and materials. In addition, the finish shall be warranted not to crack, chip, peel, or blister for the same period.

PART 3 – EXECUTION:

3.01 PREPARATION

- A. Verify areas to receive fencing are completed to final grades and elevations.
- B. Ensure property lines and legal boundaries are clearly established.
- C. Remove any surface irregularities which may cause interference with the installation of the fence.

3.02 FENCE INSTALLATION

- A. Install fence in accordance with the manufacturer's instructions.
- B. Excavate post holes to proper depth to suit local conditions for stability and support of the fence system without disturbing the underlying materials. Excavate deeper as required for adequate support in soft and loose soils.
- C. Set fence posts in concrete footers at 70" spacing from inside of post to inside of post. Note that this fence must be stepped for installations on a slope. It can not follow the grade.
- D. Center and align posts in holes to required depth. Place concrete around posts and tamp for consolidation. After tamping, check alignment of posts, and make necessary corrections before the concrete hardens.



BOARD OF CONTRACT AND SUPPLY
CITY OF PROVIDENCE, RHODE ISLAND

E. Insert rail ends into horizontal rails and fasten in place to the posts.

3.03 GATE INSTALLATION

A. Set gate posts plumb and level for gate openings specified in construction drawings.

B. Install gates to allow full opening without interference after concrete has hardened around gate posts. Adjust hardware for smooth operation. Install one drop rod for double gates.

3.04 ACCESSORIES

A. Install post caps and other accessories to complete fence.

3.05 CLEANING

A. Contractor shall clean site of debris and excess materials. Post hole excavations shall be scattered uniformly away from posts.

B. If necessary, clean fence system with mild household detergent and clean water. Excess concrete must be removed from posts and other fencing material before it hardens.



**BOARD OF CONTRACT AND SUPPLY
CITY OF PROVIDENCE, RHODE ISLAND**

ADDITIONAL INFORMATION REQUIRED WITH BID:

- Qualifications to Perform Work – See Form Below for Information Required
- Minority Participation Forms – 10% MBE / 10 % WBE Goal on this Project
- Addenda (If Any) - Must Be Acknowledged on Bid Form
- Product Information for Items Submitted as ‘Or Equal’ to Specified Materials

PROVISIONS OF THIS PROJECT:

- Upon the Issuance of the Award from the Board of Contract – the City shall issue a Contract to be executed by the City and the vendor incorporating the bid specifications. All Provisions of the Specifications are binding.
- Any Permits Required by the City of Providence and/or State of Rhode Island Shall be Obtained by the Vendor – Permit Fees by the City of Providence Shall be Waived – the State ADA Fee Must be Paid
- The Davis Bacon Act Applies– Prevailing Wages Must Be Paid for On Site Hours – On-Site Interviews will be Conducted During the Project – Employees Shall be Advised of the Prevailing Wage Rates Prior to Mobilization on Site.
- Weekly Certified payrolls must be Submitted with Pay Requests Including Monthly Utilization Form
- An Insurance Certificate Shall be Submitted to the City Within 10 Days of Award
- A Copy of the Vendors Contractor’s License Must be Submitted within 10 Days of Award
- All On-Site Personnel Shall be Licensed (If Required) and Shall have Proof of All Licenses Required by the State of Rhode Island to Perform the Work Required
- Pay Requests Must be Submitted on Approved AIA Billing Documents (City will Provide if Needed)
- All Subcontractors Shall be Listed on the Bid Form – All Insurance & Payroll Requirements Apply
 - General Contractor Shall be the Insurance Certificate Holder and the City Shall be Named as ‘Additionally Insured’ with Respect to Liability Insurance
- A Submittal Log Must be Submitted within 10 Days of Award

CLOSE OUT DOCUMENTS:

- Prior to Final Payment the Vendor Shall Provide the Following:
 - Copies of Permits Signed off and Approved (If Any)
 - Operating Manuals and Warranties Shall Be Transferred and/or Delivered
 - Full and Completed As-Built Drawings Shall be Submitted for Approval
 - Training Shall be Provided to City Personnel (If Required)
 - Certification by Manufactures Representative (If Required)



**BOARD OF CONTRACT AND SUPPLY
CITY OF PROVIDENCE, RHODE ISLAND**

QUALIFICATIONS:

Qualifications will be evaluated on the basis of similar project experience for:

- a. Completion of similar projects within the last 5 years.
- b. Size and dollar value of similar completed projects.
- c. Contractor's performance with similar projects. (references will be checked)
- d. Relevant experience of individuals assigned to the project.

Questions regarding this bid package shall be submitted via e-mail to **Patti Jordan** at pjordan@providenceri.gov and **Ben Lobaugh, Capital Improvement Project Manager** at blobaugh@providenceri.gov, no later than five (5) working days before the bid opening date.

Ben Lobaugh is the project contact and can be reached at 401-680-5548.



**BOARD OF CONTRACT AND SUPPLY
CITY OF PROVIDENCE, RHODE ISLAND**

SUPPLEMENTAL INFORMATION

If the issuing department for this RFP determines that your firm's bid is best suited to accommodate their need, you will be asked to provide proof of the following prior to formalizing an award.

An inability to provide the outlined items at the request of the department may lead to the disqualification of your bid.

*This information is **NOT** requested to be provided in your initial bid that you will submit to the City Clerk's office by the "date to be opened" noted on page 1. This list only serves as a list of items that your firm should be ready to provide on request.*

All bids submitted to the City Clerk become public record. Failure to follow instructions could result in information considered private being posted to the city's Open Meetings Portal and made available as a public record.

You must be able to provide:

- Business Tax ID will be requested after an award is approved by the Board of Contract and Supply.
- **DUN & Bradstreet (DUNS) Number** will be requested after an award is approved by the Board of Contract and Supply.
- **Unique Entity Identifier (UEI) Number** will be requested after an award is approved by the Board of Contract and Supply.
- Proof of registration at **www.sam.gov**. Firm must be registered with SAM.gov and eligible (not "debarred") from federal contracting.
- Certification of Contractor Regarding Segregated Facilities
- Certification of Bidder Regarding Equal Employment Opportunity
- MBE/WBE Subcontractor Disclosure Form
- MBE/WBE Waiver Request Form
- Proof of Insurance
- Contractor Licenses



**BOARD OF CONTRACT AND SUPPLY
CITY OF PROVIDENCE, RHODE ISLAND**

This project qualifies for prevailing wages per the Davis Bacon Act (HUD). Federal certified payrolls will need to be submitted to the owner for all hours worked on site for this project. The Wage Decision for this project shall be as recorded on the Bid Date and is available at <https://sam.gov/content/wage-determinations>.

**Federal Labor Standards
U.S. Department of Housing & Urban Development**

Applicability

The Project of Program to which the Construction work covered by this contract pertains is being assisted by the United States of America and the following Federal Labor Standards Provisions are included in this Contract pursuant to the provisions applicable to such Federal assistance.

A.1. (i) Minimum Wages. All laborers and mechanics employed or working up on the site of the work (or under the United States Housing Act of 1937 or under the Housing Act of 1949 in the construction of development of the project) will be paid unconditionally and not less often than once a week, and without subsequent deduction or rebate on any account (except such payroll deductions as are permitted by regulations issued by the Secretary of Labor under the Copeland Act (29 CFR Part 3), the full amount of wages and bona fide fringe benefits (or cash equivalents thereof) due at time of payment computed at rates not less than those contained in the wage determination of the Secretary of labor which is attached hereto and made a part hereof, regardless of any contractual relationship which may be alleged to exist between the contractor and such laborers and mechanics. Contributions made or costs reasonably anticipated for bona fide fringe benefits under Section 1(b)(2) of the Davis-Bacon Act on behalf of laborers or mechanics are considered wages paid to such laborers or mechanics, subject to the provisions of 29 CFR 5.5(a)(1)(iv); also, regular contributions made or costs incurred for more than weekly period (but not less often than quarterly) under plans, funds, or programs, which cover the particular weekly period, are deemed to be constructively made or incurred during such weekly period. Such laborers and mechanics shall be paid the appropriate wage rate and fringe benefits on the wage determination for the classification or work actually performed, without regard to skill, excepts as provided in 29 CFR Part 5.5 (a)(4). Laborers or mechanics performing work in more than one classification may be compensated at the rate specified for each classification for the time actually worked therein: Provided, that the employer's payroll records accurately set forth the time spent in each classification in which work is performed. The wage determination (including any additional classification and wage rates conformed under 29 CFT part 5.5(a)(1)(ii) and the Davis-Bacon poster (WH-1321) shall be posted at all times by the contractor and its subcontractors at the site of the work in a prominent and accessible place where it can be easily seen by the workers.

(ii) (a) Any class of laborers or mechanics which is not listed in the wage determination and which is to be employed under the contact shall be classified in conformance with the wage determination. HUD shall approve an additional classification and wage rate and fringe benefits therefore only when the following criteria have been met:

- (1) The work to be performed by the classification requested is not performed by a classification in the wage determination; and
- (2) The classification is utilized in the area by the construction industry; and
- (3) The proposed wage rate, including any bona fide fringe benefits, bears a relationship to the wage rates contained in the wage determination.

(b) If the contractor and the laborers and mechanics to be employed in the classification (if known), or their representatives, and HUD or its designee on the classification and wage rate (including the amount designated for fringe benefits where appropriate), a report of the action taken shall be sent by HUD or its designee to the Administrator of the Wage and Hour Division, Employment Standards Administration, U.S. Department of labor, Washington, D.C. 20210. The Administrator, or an authorized representative, will approve, modify, or disapprove every additional classification action within 30 days of receipt and so advise HUD or its designee or will notify HUD or its designee within the 30-day period that additional time is necessary. (Approved by the Office of Management and Budget under OMB control number 1215-0140.)

(c) In the event the contractor, the laborers or mechanics to be employed in the classification or their representatives, and HUD or its designee do not agree on the proposed classification and wage rate (including the amount designated for fringe benefits, where appropriate), HUD or its designee shall refer the questions, including the views of all interested parties and the recommendation of HUD or its designee to the Administrator for determination. The Administrator, or an authorized representative, will issue a determination within 30 days of receipt and so advise HUD or its designee or will notify HUD or its designee within the 30-day period that additional time is necessary. (Approved by the Office of Management and Budget under OMB Control Number 1215-0140.)



**BOARD OF CONTRACT AND SUPPLY
CITY OF PROVIDENCE, RHODE ISLAND**

(d) The wage rate (including fringe benefits where appropriate) determined pursuant to subparagraphs (1)(b) or (c) of this paragraph, shall be paid to all workers performing work in the classification under this contract from the first day on which work is performed in the classification.

(iii) Whenever the minimum wage rate prescribed in the contract for a class of laborers or mechanics includes a fringe benefit which is not expressed as an hourly rate, the contractor shall either pay the benefit as stated in the wage determination or shall pay another bona fide fringe benefit or an hourly cash equivalent thereof.

(iv) If the contractor does not make payments to a trustee or other third person, the contractor may consider as part of the wages of any laborer or mechanic the amount of any costs reasonably anticipated in providing bona fide fringe benefits under a plan or program, Provided, That the Secretary of Labor has found, upon the written request of the contractor, that the applicable standards of the Davis-Bacon Act have been met. The Secretary of Labor may require the contractor to set aside in a separate account assets for the meeting of obligations under the plan or program. (Approved by the Office of Management and Budget under OMB Control Number 1215-0140.)

2. Withholding. HUD or its designee shall upon its own action or upon written request of an authorized representative of the Department of Labor withhold or cause to be withheld from the contractor under this contract or any other Federal contract with the same prime contractor, or any other Federally-assisted contract subject to Davis-Bacon prevailing wage requirements, which is held by the same prime contractor so much that the accrued payments or advances as may be considered necessary to pay laborers and mechanics, including apprentices, trainees and helpers, employed by the contractor or any subcontractor the full amount of wages required by the contract. In the event of failure to pay any laborer or mechanic, including any apprentice, trainee or helper, employed or working on the site of the work (or under the United States Housing Act of 1937 or under the Housing Act of 1949 in the construction or development of the project), all or part of the wages required by the contract. HUD or its designee may, after written notice to the contractor, sponsor, applicant, or owner, take such action as may be necessary to cause the suspension of any further payment, advance, or guarantee of funds until such violations have ceased. HUD or its designee may, after written notice to the contractor, disburse such amounts withheld for and on account of the contractor or subcontractor to the respective employees to whom they are due. The comptroller General shall make such disbursements in the case of direct Davis-Bacon Act contracts.

3. (i) Payrolls and basic records. Payrolls and basic record relating thereto shall be maintained by the contractor during the course of the work preserved for a period of three years thereafter for all laborers and mechanics working at the site of the work (or under the United States Housing Act of 1937, or under the Housing Act of 1949, in the construction or development of the project). Such records shall contain the name, address, and social security number of each such worker, his or her correct classification, hourly rates of wages paid (including rates of contributions or costs anticipated for bona fide fringe benefits or cash equivalents thereof of the types described in Section 1(b)(2)(B) of the Davis-Bacon Act), daily and weekly number of hours worked, deductions made and actual wages paid. Whenever the Secretary of labor has found under 29 CFR 5.5 (a)(1)(iv) that the wages of any laborer or mechanic include the amount of any costs reasonable anticipated in providing benefits under a plan or program described in Section 1(b)(2)(B) or the Davis-Bacon Act, the contractor shall maintain records which show that the commitment to provide such benefits ins enforceable, that the plan or program is financially responsible, and that the plan or program has been communicated in writing to the laborers or mechanics affected, and records which show the costs anticipated or the actual cost incurred in providing such benefits. Contractors employing apprentices or trainees under approved programs shall maintain written evidence of the registration of apprenticeship and certification of trainee programs, the registration of the apprentices and trainees, and the ratios and wage rates prescribed in the applicable programs. (Approved by the Office of Management and Budget under OMB Control Numbers 1215-0140 and 1215-0017.)

(ii) (a) The contractor shall submit weekly for each in which any contract work is performed a copy of all payrolls to HUD or its designee if the agency is a party to the contract, but if the agency is not such a party, the contractor will submit the payrolls to the applicant, sponsor or owner, as the case may be, for transmission to HUD or its designee. The payrolls submitted shall set out accurately and completely all of the information required to be maintained under 29 CFR Part 5.5(a)(3)(i). This information may be submitted in any form desired. Optional Form WH-34 is available for this purpose and may be purchases from the Superintendent of Documents (Federal Stock Number 029-005-00014-1), Government Printing Office, Washington, Dc 20402. The prime contractor is responsible for the submission of copies of payrolls by all subcontractors. (Approved by the Office of Management and Budget under OMB Control Number 1215-0149.)

(b) Each payroll submitted shall be accompanied by a "Statement of Compliance," signed by the contractor or his or her agent who pays or supervises the payment of the persons employed under the contract and shall certify the following:

(1) That the payroll for the payroll period contains the information required to be maintained under 20 CFR Part 5.5 (a)(3)(i) and that such information is correct and complete;



**BOARD OF CONTRACT AND SUPPLY
CITY OF PROVIDENCE, RHODE ISLAND**

(2) That each laborer or mechanic (including each helper, apprentice, and trainee) employed on the contract during the payroll period has been paid the full weekly wages earned, without rebate, either directly or indirectly, and that no deductions have been made either directly or indirectly from the full wages earned, other than permissible deductions as set forth in 29 CFR Part 3;

(3) That each laborer or mechanic has been paid not less than the applicable wage rates and fringe benefits or cash equivalents for the classification of work performed, as specified in the applicable wage determination incorporated into the contract.

(c) The weekly submission of a properly executed certification set forth on the reverse side of Optional Form WH-347 shall satisfy the requirement for submission of the "Statement of Compliance" required by paragraph AA.3. (ii)(b) of this section.

(d) The falsification of any of the above certifications may subject the contractor or subcontractor to civil or criminal prosecution under Section 1001 of Title 18 and Section 231 of Title 31 of the United States Code.

(iii) The contractor or subcontractor shall make the records required under paragraph A.3. (i) of this section available for inspection, copying, or transcription by authorized representatives of HUD or its designee or the Department of Labor, and shall permit such representatives to interview employees during working hours on the job. If the contractor or subcontractor fails to submit the required records or to make them available, HUD or its designee may, after written notice to the contractor, sponsor, applicant, or owner, take such action as may be necessary to cause the suspension of any further payment, advance, or guarantee of funds. Furthermore, failure to submit the required records upon request or to make such records available may be grounds for debarment action pursuant to 29 CFR Part 5.12.

4. (i) Apprentices and Trainees. Apprentices. Apprentices will be permitted to work at less than the predetermined rate for the work they performed when they are employed pursuant to and individually registered in a bona fide apprenticeship program registered with the U.S. Department of Labor, Employment and Training Administration, Bureau of Apprenticeship and Training, or with a State Apprenticeship Agency recognized by the Bureau, or if a person is employed in his or her first 90 days of probationary employment as an apprentice in such an apprenticeship program, who is not individually registered in the program, but who has been certified by the Bureau of Apprenticeship and Training or a State Apprenticeship Agency (where appropriate) to be eligible for probationary employment as an apprentice. The allowable ratio of apprentices to journeymen on the job site in any craft classification shall not be greater than the ratio permitted to the contractor as to the entire work force under the registered program. Any worker listed on a payroll at an apprentice wage rate, who is not registered or otherwise employed as stated above, shall be paid not less than the applicable wage rate on the wage determination for the classification of work actually performed. In addition, any apprentice performing work on the job site in excess of the ratio permitted under the registered program shall be paid not less than the applicable wage rate on the wage determination for the work actually performed. Where a contractor is performing construction on a project in a locality other than that in which its program is registered, the ratios and wage rates (expressed in percentages of the journeyman's hourly rate) specified in the contractor's or subcontractor's registered program shall be observed. Every apprentice must be paid at not less than the rate specified in the registered program for the apprentice's level of progress, expressed as a percentage of the journeymen hourly rate specified in the applicable wage determination. Apprentices shall be paid fringe benefits in accordance with the provisions of the apprenticeship program. If the apprenticeship program does not specify fringe benefits, apprentices must be paid the full amount of fringe benefits listed on the wage determination for the applicable classification. If the Administrator determines that a different practice prevails for the applicable apprentice classification, fringes shall be paid in accordance with that determination. In the event the Bureau of Apprenticeship and Training, or a State Apprenticeship Agency recognized by the Bureau, withdraws approval of an apprenticeship program, the contractor will no longer be permitted to utilize apprentices at less than the applicable predetermined rate for the work performed until an acceptable program is approved.

(ii) Trainees. Except as provided in 29 CFR 5.16, trainees will not be permitted to work at less than the predetermined rate for the work performed unless they are employed pursuant to and individually registered in a program which has received prior approval, evidenced by formal certification by the U.S. Department of Labor, Employment and Training Administration. The ratio of trainees to journeymen on the job site shall not be greater than permitted under the plan approved by the Employment and Training Administration. Every trainee must be paid not less than the rate specified in the approved program for the trainee's level of progress, expressed as a percentage of the journeyman hourly rate specified in the applicable wage determination. Trainees shall be paid fringe benefits in accordance with the provisions of the trainee program. If the trainee program does not mention fringe benefits, trainees shall be paid the full amount of fringe benefits listed on the wage determination unless the Administrator of the Wage and Hour Division determines that there is an apprenticeship program associated with the corresponding journeyman wage rate on the wage determination which provides for less than full fringe benefits for apprentices. Any employee listed on the payroll at a trainee rate who is not registered and participating in a training plan approved by the Employment and Training Administration shall be paid not less than the applicable wage rate on the wage determination for the work actually performed. In addition, any trainee performing work on the job site in excess of the ratio permitted under the registered program shall be paid not less than the applicable wage rate on the wage determination for the work actually performed. In the event the Employment and Training Administration withdraws approval of a training program, the contractor will no longer be permitted to utilize trainees at less than the applicable predetermined rate for the work performed until an acceptable program is approved.



**BOARD OF CONTRACT AND SUPPLY
CITY OF PROVIDENCE, RHODE ISLAND**

(iii) Equal employment opportunity. The utilization of apprentices, trainees and journeymen under this part shall be in conformity with the equal employment opportunity requirement of Executive Order 11246, s amended, and 29 CFR Part 30.

5. Compliance with Copeland Act requirements. The contractor shall comply with the requirements of 29 CFR Part 3, which are incorporated by reference in this contract.

6. Subcontracts. The contractor or subcontractor will insert in any subcontract the clauses contained in 29 CFR 5.5(a)(1) through (10) and such other clauses as HUD or its designee may by appropriate instructions require, and also a clause requiring the subcontractors to include these clauses in any lower tier subcontracts. The prime contractor shall be responsible for the compliance by any subcontractor or lower tier subcontractor with all contract clauses in 29 CFR Part 5.5

7. Contracts termination; debarment. A breach of the contract clauses in 29 CFR 5.5 may be grounds for termination of the contract, and for debarment as a contractor as provided in 29 CFR 5.12.

8. Compliance with Davis-Bacon and Related Act Requirements. All ruling and interpretations of the Davis-Bacon and Related Act contained in 29 CFR Parts 1, 3, and 5 are herein incorporated by reference in this contract.

9. Disputes concerning labor standards. Disputes arising out of the labor standards provisions of this contract shall not be subject to the general disputes clause of this contract. Such disputes shall be resolved in accordance with the procedures of the Department of Labor set forth in 29 CFR Parts 5, 6, and 7. Disputes within the meaning of this clause include disputes between the contractor (or any of its subcontractors) and HUD or its designee, the U.S. Department of Labor, or the employees or their representatives.

10. (i) Certification of Eligibility. By entering in to this contract, the contractor certifies that neither it (nor he or she) nor any person or firm who has an interest in the contractor's firm is a person or firm ineligible to be awarded Government contracts by virtue of Section 3(a) of the Davis-Bacon Act or 29 CFR 5.12(a)(1) or to be awarded HUD contracts or participate in HUD programs pursuant to 24 CFR part 24.

(ii) No part of this contract shall be subcontracted to any person or firm ineligible for award of a Government contract by virtue of Section 3(a) of the Davis-Bacon Act of 29 CFR 5.12(a)(1) or to be awarded HUD contracts or participate in HUD programs pursuant to 24 CFR Part 24.

(iii) The penalty to making false statements is prescribed in the U.S. Criminal Code, 18 U.S.C. 1001. Additionally, U.S. Criminal Code, Section 1010, Title 18, U.S.C., "Federal Housing Administration transaction", provides in part: "Whoever, for the purpose of ...influencing in any way the action of such Administration...makes, utter of publishes any statement, knowing the same to be false...shall be fined not more than \$5,000 or imprisoned not more than two years, or both."

11. Complaints, Proceedings, or Testimony by Employees. No laborer or mechanic to whom the wage, salary, or other labor standards provisions of this Contract are applicable shall be discharged or in any other manner discriminated against by the Contractor or any subcontractor because such employee has filed any complaint or instituted or caused to be instituted any proceeding or has testified or is about to testify in any proceeding under or relating to the labor standards applicable under this Contract to his employer.

B. Contract Work Hours and Safety Standards Act. As used in this paragraph, the terms "laborers" and "mechanics" include watchmen and guards.

(1) Overtime requirements. No contractor or subcontractor contracting for any part of the contract work which may require or involve the employment of laborers or mechanics shall require or permit any such laborer or mechanic in any workweek in which he or she is employed on such work to work I excess of forty hours I such workweek unless such laborer or mechanic receives compensation at a rate not less than one and one-half times the basic rate of pay for all hours worked in excess of forty hours in such workweek.

(2) Violation; liability for unpaid wages; liquidated damages. In the event of any violation of the clause set forth in subparagraph (1) or this paragraph, the contractor and any subcontractor responsible therefore shall be liable for the unpaid wages. In addition, such contractor and subcontractor shall be liable to the United States (in case of work done under contract for the District of Columbia or a territory, to such District or to such territory), for liquidated damages. Such liquidated damages shall be computed with respect to each individual laborer or mechanic, including watchmen and guards, employed in violation of the clause set forth in subparagraph (1) of this paragraph, in the sum of \$25 for each calendar day on which such individual was required or permitted



**BOARD OF CONTRACT AND SUPPLY
CITY OF PROVIDENCE, RHODE ISLAND**

to work in excess of forty hours without payment of the overtime wages required by the clause set forth in subparagraph (1) of this paragraph.

(3) Withholding for unpaid wages for liquidated damages. HUD or its designees shall upon its own action or upon written request of an authorized representative of the Department of Labor withhold of cause to be withheld from any moneys payable on account of work performed by the contractor or subcontractor under any such contract or any other Federal contract with the same prime contract, or any other Federally-assisted contract subject to the Contract Work Hours and Safety Standards Act, which is held by the same prime contractor such sums as may be determined to be necessary to satisfy any liabilities of such contractor or subcontractor for unpaid wages and liquidates damages as provided in the clause set forth in subparagraph (2) of this paragraph.

(4) Subcontracts. The contractor or subcontractor shall insert in any subcontracts the clauses set forth in subparagraph (1) through (4) of this paragraph and also a clause requiring the subcontractors to include these clauses in any lower tier subcontracts. The prime contractor shall be responsible for compliance by any subcontractor or lower tier subcontractor with the clauses set forth in subparagraphs (1) through (4) of this paragraph.

C. Health and Safety

(1) No laborer or mechanic shall be required to work in surrounding or under working conditions which are unsanitary, hazardous, or dangerous to his health and safety as determined under construction safety and health standards promulgated by the Secretary of Labor by regulation.

(2) The Contractor shall comply with all regulations issued by the Secretary of Labor pursuant to Title 29 Part 1926 (formerly Part 1518) and failure to comply may result in imposition of sanctions pursuant to the Contract Work Hours and Safety Standards Act (Public Law 91-54, 83 Stat. 96).

(3) The Contractor shall include the provisions of this Article in every subcontract so that such provisions will be binding on each subcontractor. The Contractor shall take such action with respect to any subcontract as the Secretary of Housing and Urban Development or the Secretary of Labor shall direct as a means of enforcing such provisions.

Questions regarding this bid shall be sent via e-mail to Ben Lobaugh at blobaugh@providenceri.gov. Questions and responses will be sent to all bidders.



**BOARD OF CONTRACT AND SUPPLY
CITY OF PROVIDENCE, RHODE ISLAND**

CITY OF PROVIDENCE STANDARD TERMS & CONDITIONS

1. The terms “you” and “your” contained herein refer to the person or entity that is a party to the agreement with the City of Providence (“the City”) and to such person’s or entity’s employees, officers, and agents.
2. The Request For Proposals (“RFP”) and these Standard Terms and Conditions together constitute the entire agreement of the parties (“the Agreement”) with regard to any and all matters. By your submission of a bid proposal or response to the City’s RFP, you accept these Standard Terms & Conditions and agree that they supersede any conflicting provisions provided by bid or in any terms and conditions contained or linked within a bid and/or response. Changes in the terms and conditions of the Agreement, or the scope of work thereunder, may only be made by a writing signed by the parties.
3. You are an independent contractor and in no way does this Agreement render you an employee or agent of the City or entitle you to fringe benefits, workers’ compensation, pension obligations, retirement or any other employment benefits. The City shall not deduct federal or state income taxes, social security or Medicare withholdings, or any other taxes required to be deducted by an employer, and this is your responsibility to yourself and your employees and agents.
4. You shall not assign your rights and obligations under this Agreement without the prior written consent of the City. Any assignment without prior written consent of the City shall be voidable at the election of the City. The City retains the right to refuse any and all assignments in the City’s sole and absolute discretion.
5. Invoices submitted to the City shall be payable sixty (60) days from the time of receipt by the City. Invoices shall include support documentation necessary to evidence completion of the work being invoiced. The City may request any other reasonable documentation in support of an invoice. The time for payment shall not commence, and invoices shall not be processed for payment, until you provide reasonably sufficient support documentation. In no circumstances shall the City be obligated to pay or shall you be entitled to receive interest on any overdue invoice or payment. In no circumstances shall the City be obligated to pay any costs associated with your collection of an outstanding invoice.
6. For contracts involving construction, alteration, and/or repair work, the provisions of applicable state labor law concerning payment of prevailing wage rates (R.I. Gen. Laws §§ 37-13-1 et seq., as amended) and the City’s First Source Ordinance (Providence Code of Ordinances §§ 21-91 et seq., as amended) apply.
7. With regard to any issues, claims, or controversies that may arise under this Agreement, the City shall not be required to submit to dispute resolution or mandatory/binding arbitration. Nothing prevents the parties from mutually agreeing to settle any disputes using mediation or non-binding arbitration.
8. To the fullest extent permitted by law, you shall indemnify, defend, and hold harmless the City, its employees, officers, agents, and assigns from and against any and all claims, damages, losses, allegations, demands, actions, causes of action, suits, obligations, fines, penalties, judgments, liabilities, costs and expenses, including but not limited to attorneys’ fees, of any nature whatsoever arising out of, in connection with, or resulting from the performance of the work provided in the Agreement.
9. You shall maintain throughout the term of this Agreement the insurance coverage that is required by the RFP or, if none is required in the RFP, insurance coverage that is considered in your industry to be commercially reasonable, and you agree to name the City as an additional insured on your general liability policy and on any umbrella policy you carry.
10. The City shall not subject itself to any contractual limitations on liability. The City shall have the time permitted within the applicable statute of limitations, and no less, to bring or assert any and all causes of action, suits, claims or demands the City may have arising out of, in connection with, or resulting from the performance of the work provided in the Agreement, and in no event does the City agree to limit your liability to the price of the Agreement or any other monetary limit.
11. The City may terminate this Agreement upon five (5) days’ written notice to you if you fail to observe any of the terms and conditions of this Agreement, or if the City believes your ability to perform the



**BOARD OF CONTRACT AND SUPPLY
CITY OF PROVIDENCE, RHODE ISLAND**

terms and conditions of this Agreement has been materially impaired in any way, including but in no way limited to loss of insurance coverage, lapsing of a surety bond, if required, declaration of bankruptcy, or appointment of a receiver. In the event of termination by the City, you shall be entitled to just and equitable compensation for any satisfactory work completed and expenses incurred up to the date of termination.

12. Written notice hereunder shall be deemed to have been duly served if delivered in person to the individual or member of the firm or entity or to an officer of the entity for whom it was intended, or if delivered at or sent by registered or certified mail to the last business address known by the party providing notice.
13. In no event shall the Agreement automatically renew or be extended without a writing signed by the parties.
14. You agree that products produced or resulting from the performance of the Agreement are the sole property of the City and may not be used by you without the express written permission of the City.
15. For any Agreement involving the sharing or exchange of data involving potentially confidential and/or personal information, you shall comply with any and all state and/or federal laws or regulations applicable to confidential and/or personal information you receive from the City, including but not limited to the Rhode Island Identity Theft Protection Act, R.I. Gen. Laws § 11-49.3-1, during the term of the Agreement. You shall implement and maintain appropriate physical, technical, and administrative security measures for the protection of, and to prevent access to, use, or disclosure of, confidential and/or personal information. In the event of a breach of such information, you shall notify the City of such breach immediately, but in no event later than twenty-four (24) hours after discovery of such breach.
16. The Agreement is governed by the laws of the State of Rhode Island. You expressly submit yourself to and agree that any and all actions arising out of, in connection with, or resulting from the performance of the Agreement or relationship between the parties shall occur solely in the venue and jurisdiction of the State of Rhode Island or the federal court located in Rhode Island.
17. The failure of the City to require performance of any provision shall not affect the City's right to require performance at any time thereafter, nor shall a waiver of any breach or default of this Agreement constitute a waiver of any subsequent breach or default or a waiver of the provision itself.
18. If any term or provision of this Agreement, or the application thereof to any person or circumstance shall, in any extent, be invalid or unenforceable, the remainder of this Agreement shall not be affected thereby, and each term and provision shall be valid and enforceable to the fullest extent permitted by law.



**BOARD OF CONTRACT AND SUPPLY
CITY OF PROVIDENCE, RHODE ISLAND**

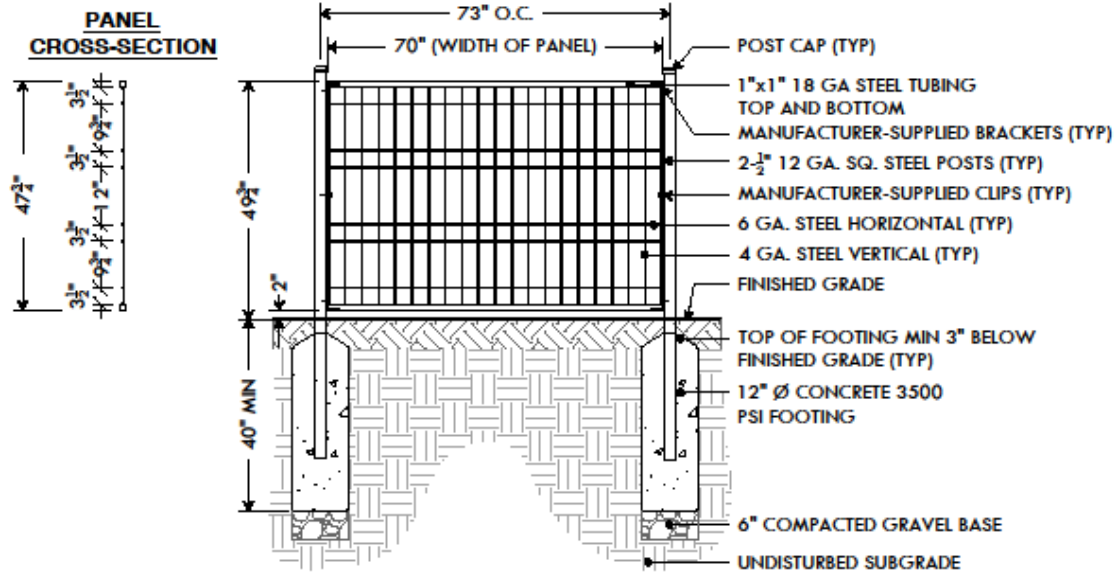

PROVIDENCE
PARKS
DEPARTMENT
DALKRIMPLE
BOATHOUSE
ROGER
WILLIAMS PARK
PROVIDENCE, RI

FILE: 4P-Walked With Concrete/Fence-2022.dwg

(SHEET TITLE)
(PROJECT NAME)
(ADDRESS)

DATE:
XX/XX/XX

SCALE:
1"=X'-0"

SHEET NO.
X

OF (#)

COPYRIGHT (C) CITY OF PROVIDENCE PARKS DEPARTMENT, ALL RIGHTS RESERVED 2018.	DRAWN BY: XX
	CHECKED/ APPROVED: XX



**BOARD OF CONTRACT AND SUPPLY
CITY OF PROVIDENCE, RHODE ISLAND**

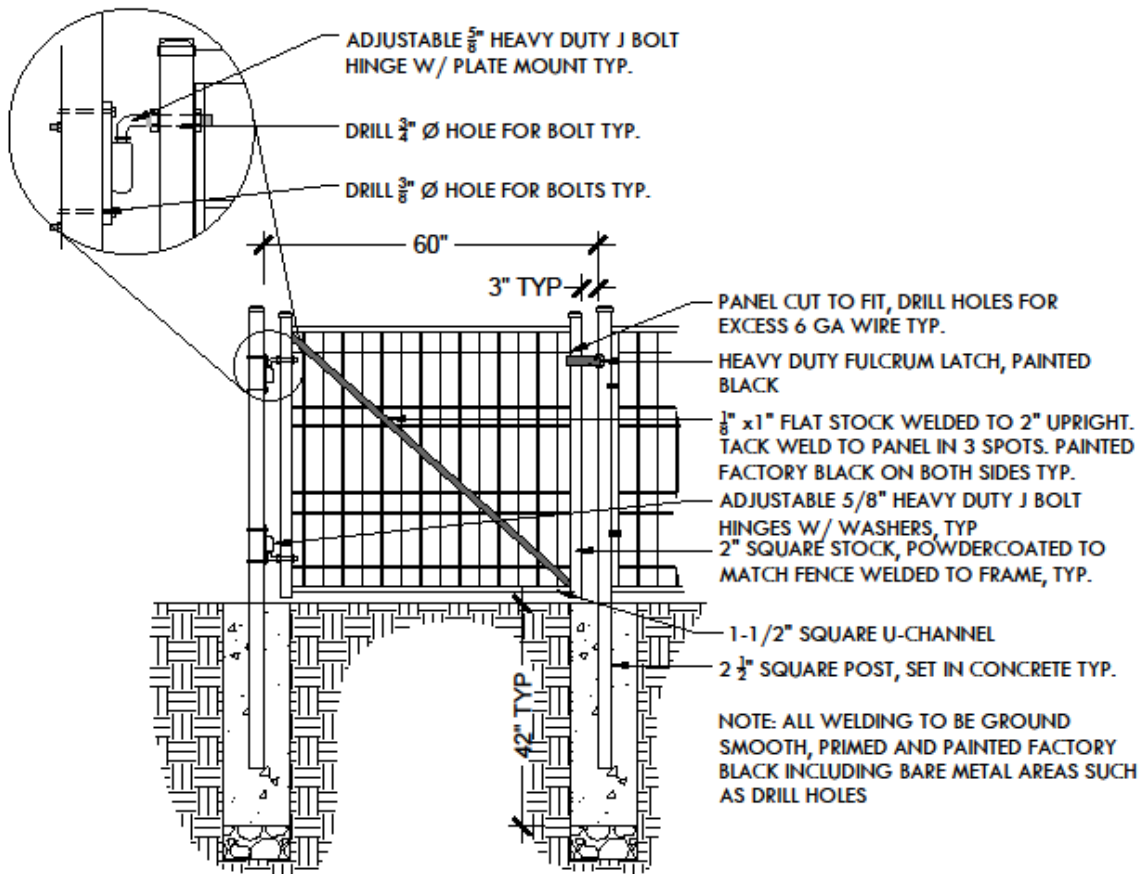

FILE: JT Owens Playground_8' Walked Wire Ornamental Gate.dwg

(SHEET TITLE)
(PROJECT NAME)
(ADDRESS)

DATE	XX/XX/XX
SCALE	1"=X'-0"
SHEET NO.	X
OF	(#)

COPYRIGHT (C) CITY OF PROVIDENCE PARKS DEPARTMENT. ALL RIGHTS RESERVED 2018.	DRAWN BY:	XX
	CHECKED/ APPROVED:	XX



**BOARD OF CONTRACT AND SUPPLY
CITY OF PROVIDENCE, RHODE ISLAND**

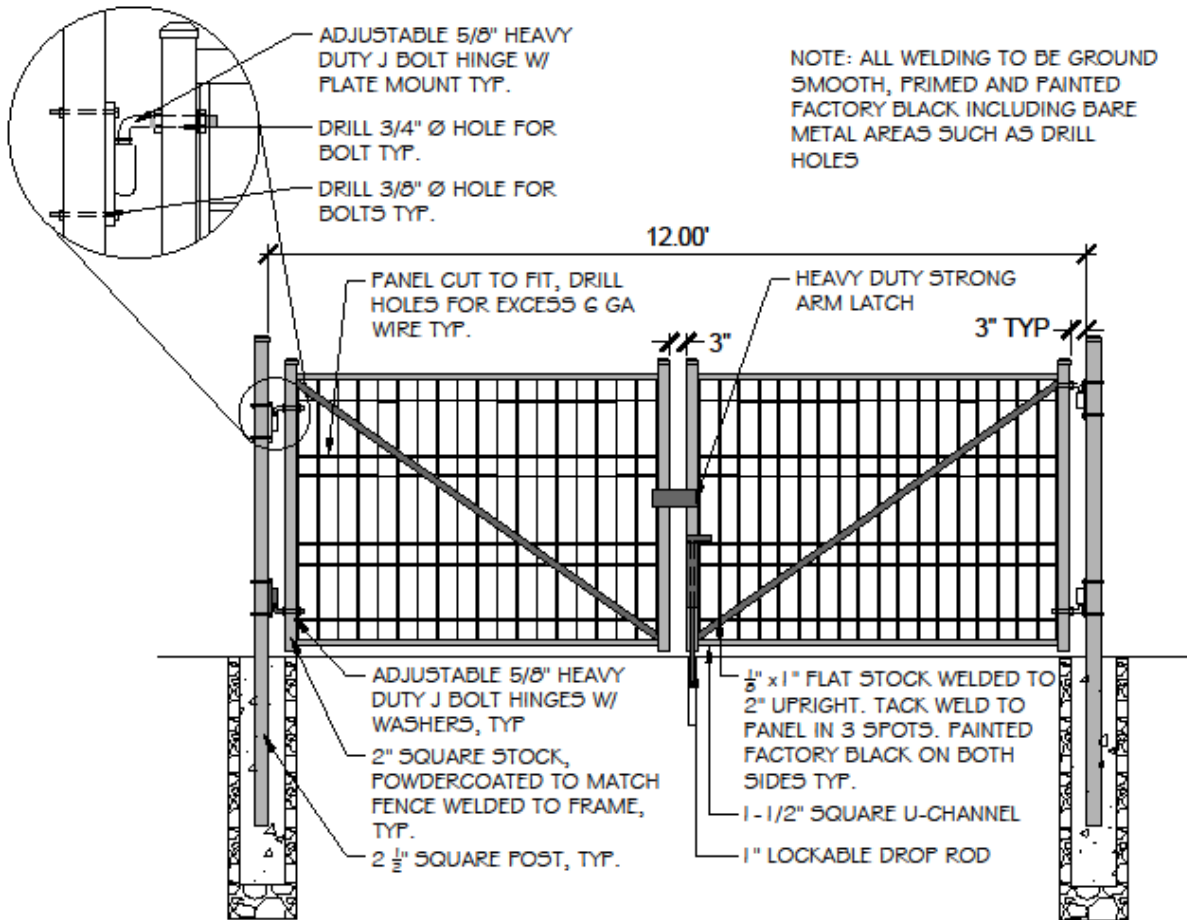

NOTE: ALL WELDING TO BE GROUND SMOOTH, PRIMED AND PAINTED FACTORY BLACK INCLUDING BARE METAL AREAS SUCH AS DRILL HOLES



4FT HT, 12FT SERVICE GATE
JERITH PATRIOT FENCING

DATE:	08/27/21
SCALE:	1/2" = 1'-0"
SHEET NO.:	A
OF	1

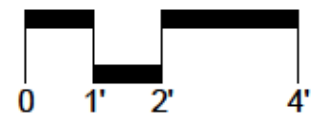

COPYRIGHT (C) CITY OF PROVIDENCE PARKS DEPARTMENT, ALL RIGHTS RESERVED 2018.	DRAWN BY:	SG
	CHECKED/ APPROVED:	MG