



PROVIDENCE WATER

**PROJECT MANUAL
FOR
ACCELERATED LEAD SERVICE LINE REPLACEMENT
PROGRAM – CONTRACT 1.4
PROJECT NO. 20234**

MARCH 2024

THE HON. BRETT P. SMILEY
MAYOR

ATEESH S. CHANDA
CHAIRPERSON

JUAN M. PICHARDO
COUNCIL PRESIDENT PRO
TEMPORE

SARA SILVERIA
EX-OFFICIO

DR. ALMA M. GUERRERO BREADY
MEMBER



RICKY CARUOLO
GENERAL MANAGER

JOSEPH D. CATALDI
VICE CHAIRPERSON

OSCAR O. VARGAS
COUNCILPERSON

CRISTEN L. RAUCCI, ESQ.
MEMBER

CARISSA R. RICHARD
SECRETARY

WILLIAM E. O'GARA, ESQ.
LEGAL ADVISOR

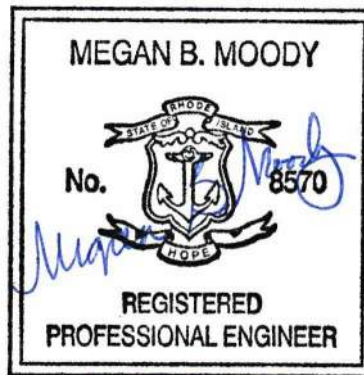

3-8-2024

Prepared by:



**PROVIDENCE WATER SUPPLY BOARD
 ACCELERATED LEAD SERVICE LINE REPLACEMENT PROGRAM – CONTRACT 1.4
 PROJECT NO. 20234**

TABLE OF CONTENTS

DIVISION 00	PROCUREMENT AND CONTRACTING REQUIREMENTS	
001000	BOCS Terms & Requirements for Bidding (Instructions for Submission)	30
001116	Invitation to Bid	2
002113	Instructions to Bidders	13
003000	Available Information	2
004100	Bid Form	9
004336	Proposed Subcontractors & Suppliers.....	2
004513	Bidder’s Qualifications	12
005200	Agreement	9
006113.13	Performance Bond.....	4
006113.16	Payment Bond	4
007200	General Conditions of the Contract	79
007300	Supplementary Conditions.....	35
DIVISION 01	GENERAL REQUIREMENTS	
01010	Summary of Work	4
01014	Construction Sequence and Schedule Requirements.....	5
01025	Measurement and Payment	21
01026	Application for Payment.....	7
01038	Requests for Information.....	3
01045	Cutting, Coring and Patching.....	4
01046	Control of Work.....	7
01110	Environmental Protection Procedures.....	6
01170	Special Provisions.....	18
01180	Pipe Penetrations.....	3
01300	Submittals.....	16
01310	Construction Scheduling.....	4
01322	Photographic Documentation.....	5
01370	Schedule of Values.....	2
01410	Testing and Testing Laboratory Services.....	4
01500	Temporary Facilities.....	1
01576	Traffic Control.....	5
01580	Project Identification Signs.....	6
01601	Control of Materials.....	2
01700	Contract Closeout.....	2
01720	Project Record Documents.....	5
DIVISION 02	SITE WORK	
02140	Dewatering and Drainage.....	5
02151	Utility Impact Molding.....	4
02213	Rock and Boulder Excavation.....	2
02221	Trenching, Backfilling and Compaction.....	6
02230	Granular Fill Materials.....	3
02270	Sedimentation and Erosion Control.....	2
02311	Excavation Support and Protection.....	8

02576	Pavement Repair and Resurfacing.....	9
02577	Infra-Red Pavement Repair and Patching.....	6
02616	Ductile Iron Pipe and Fittings.....	6
02663	Water Service Connections.....	12
02768	Pipe Pulling (Extraction).....	3
02930	Loaming and Seeding.....	4
DIVISION 03	CONCRETE	
03301	Concrete and Reinforcing Steel.....	7
DIVISION 04	MECHANICAL	
15050	Interior Piping – General Requirements.....	3
15410	Interior Service Piping and Appurtenances	8

APPENDICES

A	Contract Addresses (Initial List)
B	Construction Details
C	Locations that Require Final Paving
D	RIDOT – Minimum Standards for State and Municipal Road Repair for Utility Work
E	City of Providence – Standards to be Employed by Licensed Sidewalk Contractors for Road and Sidewalk Openings
F	List of Approved Materials/Manufacturers for Use in the Providence Water Distribution System
G	EPA – American Iron and Steel (AIS) Requirements
H	EPA – Davis-Bacon Prevailing Wage Requirements
I	EPA – Debarment and Suspension
J	EPA – Prohibition on Certain Telecommunication and Video Surveillance
K	EPA General Terms and Conditions
L	RI Office of Diversity, Equity, and Opportunity MBE Forms
M	National Grid Cast Iron Gas Main Encroachment Prevention
N	City of Providence MBE WBE Forms
O	Apprentice Utilization, Local Hiring Requirements and Air Quality Protocols
P	City of Providence Contract Terms and Conditions
Q	Copland Act
R	Rhode Island Prevailing Wage Rates
S	Build America, Buy America Act Implementation Procedures
T	Relevant Federal and State Laws Applicable to The Drinking Water State Revolving Fund Program



BOARD OF CONTRACT AND SUPPLY
CITY OF PROVIDENCE, RHODE ISLAND

REQUEST FOR PROPOSALS

Item Description: ACCLERATED LEAD SERVICE LINE REPLACEMENT PROGRAM –

CONTRACT 1.4 (Exp. 12-13/2025)

Procurement/MinuteTraq #: 44501

Date to be opened: 2:15 P.M. ON 5/6/2024

Issuing Department: Providence Water Supply Board

QUESTIONS

- Please direct questions related to the bidding process, how to fill out forms, and how to submit a bid (Pages 1-12) to the Purchasing Department.
 - Email: purchasing@providenceri.gov
 - Please use the subject line “**Solicitation Question**”
- Please direct questions relative to the Minority and Women’s Business Enterprise Program and the corresponding forms (Pages 13-15) to the MBE/WBE Outreach Director for the City of Providence,
Grace Diaz
 - Email: gdiaz@providenceri.gov
 - Please use subject line “**MBE WBE Forms**”
- Please direct questions relative to the specifications outlined (beginning on page 16) to the issuing department’s subject matter expert:
 - Name: **Megan Moody, P.E.**
 - Title: **Project Manager**
 - Email Address: moodymb@cdmsmith.com

Pre-bid Conference

There will be a Non-Mandatory Pre-Bid Conference.

Date of Pre-Bid Conference: 4/4/2024 Time: 2:00 PM

Other details (e.g. location, links, question submission deadline): **Virtual meeting will be held on the Microsoft Teams Meeting platform. Bidders are not required to attend and participate in the Pre-Bid Conference, however attendance is strongly recommended.**



Microsoft Teams [Need help?](#)

[Join the meeting now](#)

Meeting ID: 291 530 347 705

Passcode: Yi28HY

Dial-in by phone

[+1 857-327-8948,,761492976#](#) United States, Boston

[\(844\) 566-5330,,761492976#](#) United States (Toll-free)

[Find a local number](#)

Phone conference ID: 761 492 976#

Deadline for questions submissions: 4/26/2024



**BOARD OF CONTRACT AND SUPPLY
CITY OF PROVIDENCE, RHODE ISLAND**

INSTRUCTIONS FOR SUBMISSION

Meeting Date: 5/6/2024

Bids may be submitted up to **2:15 P.M.** on the above meeting date at the **Department of the City Clerk, Room 311, City Hall, 25 Dorrance Street, Providence.** At 2:15 P.M. all bids will be publicly opened and read at the Board of Contract Meeting in Conference Room 305, on the 3rd floor of City Hall.

- Bidders must submit **2 copies** of their bid in sealed envelopes or packages labeled with the captioned **Item Description** and the **City Department to which the solicitation and bid are related and must include the company name and address on the envelope as well.** (On page 1).
- If required by the Department, please keep the original bid bond and check in only one of the envelopes.
- Communications to the Board of Contract and Supply that are not competitive sealed bids (i.e. product information/samples) should have “**NOT A BID**” written on the envelope or wrapper.
- Only use form versions and templates included in this solicitation. If you have an old version of a form do not recycle it for use in this bid.
- The bid envelope and information relative to the bid must be addressed to:

**Board of Contract and Supply
Department of the City Clerk – City Hall, Room 311
25 Dorrance Street
Providence, RI 02903**

****PLEASE NOTE:** This bid may include details regarding information that you will need to provide (such as proof of licenses) to the issuing department before the formalization of an award.

*This information is **NOT** requested to be provided in your initial bid by design.*

All bids submitted to the City Clerk become public record. Failure to follow instructions could result in information considered private being posted to the city’s Open Meetings Portal and made available as a public record. The City has made a conscious effort to avoid the posting of sensitive information on the City’s Open Meetings Portal, by requesting that such sensitive information be submitted to the issuing department only at their request.



**BOARD OF CONTRACT AND SUPPLY
CITY OF PROVIDENCE, RHODE ISLAND**

BID PACKAGE CHECKLIST

Bid Documents (drawings, specifications, etc.) can be obtained from the City of Providence Bid Opportunities web portal at <https://www.bidnetdirect.com/rhode-island/providenceri>

Digital forms are available in the City of Providence Purchasing Department Office or online at <http://www.providenceri.gov/purchasing/how-to-submit-a-bid/>

The bid package **MUST** include the following, in this order:

- Bid Form 1: Bidder's Blank as the cover page/ 1st page (*see page 7 of this document*)
- Bid Form 2: Certification of Bidder as 2nd page (*see page 8 of this document*)
- Bid Form 3: Certificate Regarding Public Records (*see page 9 of this document*)
- Bid Form 4: Affidavit of City Vendor (*see pages 10 and 11 of this document*)
- Bid Form 5: Bidder Certification, Performance of Work (*see page 12 of this document*)
- Forms from the Minority and Women Business Enterprise Program: Based on Bidder Category. *See forms and instructions enclosed (pages 13-14) or on:*
<https://www.providenceri.gov/purchasing/minority-women-owned-business-mbewbe-procurement-program/>
- Completed Forms for the EPA Disadvantaged Enterprise (DBE) Program. *See forms and instructions enclosed (pages 16-27)*
 - [EPA Form 6100-3](#)
 - [EPA Form 6100-4](#)

***Please note: MBE/WBE and DBE forms must be completed for EVERY bid submitted and must be inclusive of ALL required signatures. Forms without all required signatures will be considered incomplete.**

- Bidder's Proposal/Packet: Formal response to the specifications outlined in this RFP, including pricing information and details related to the good(s) or service(s) being provided. Please be mindful of formatting responses as requested to ensure clarity.
- Financial Assurance, *if requested (as indicated on page 6 of this document under "Bid Terms")*

All of the above listed documents are REQUIRED. (With the exception of financial assurances, which are only required if specified under Bid Terms below.)

*****Failure to meet specified deadlines, follow specific submission instructions, or enclose all required documents with all applicable signatures will result in disqualification, or in an inability to appropriately evaluate bids.**



**BOARD OF CONTRACT AND SUPPLY
CITY OF PROVIDENCE, RHODE ISLAND**

NOTICE TO VENDORS

1. The Board of Contract and Supply will make the award to the lowest qualified and responsible bidder.
2. In determining the lowest responsible bidder, cash discounts based on preferable payment terms will not be considered.
3. Where prices are the same, the Board of Contract and Supply reserves the right to award to one bidder, or to split the award.
4. No proposal will be accepted if the bid is made in collusion with any other bidder.
5. Bids may be submitted on an “equal in quality” basis. The City reserves the right to decide equality. Bidders must indicate brand or the make being offered and submit detailed specifications if other than brand requested.
6. A bidder who is an out-of-state corporation shall qualify or register to transact business in this State, in accordance with the Rhode Island Business Corporation Act, RIGL Sec. 7-1.2-1401, et seq.
7. The Board of Contract and Supply reserves the right to reject any and all bids.
8. Competing bids may be viewed in person at the Department of the City Clerk, City Hall, Providence, immediately upon the conclusion of the formal Board of Contract and Supply meeting during which the bids were unsealed/opened. Bids may also be accessed electronically on the internet via the City’s [Open Meetings Portal](#).
9. As the City of Providence is exempt from the payment of Federal Excise Taxes and Rhode Island Sales Tax, prices quoted are not to include these taxes.
10. In case of error in the extension of prices quoted, the unit price will govern.
11. The contractor will **NOT** be permitted to: a) assign or underlet the contract, or b) assign either legally or equitably any monies or any claim thereto without the previous written consent of the City Purchasing Director.
12. Delivery dates must be shown in the bid. If no delivery date is specified, it will be assumed that an immediate delivery from stock will be made.
13. A certificate of insurance will normally be required of a successful vendor.
14. For many contracts involving construction, alteration and/or repair work, State law provisions concerning payment of prevailing wage rates apply ([RIGL Sec. 37-13-1 et seq.](#))
15. No goods should be delivered, or work started without a Purchase Order.
16. **Submit 2 copies of the bid to the City Clerk, unless the specification section of this document indicates otherwise.**
17. Bidder must certify that it does not unlawfully discriminate on the basis of race, color, national origin, gender, gender identity or expression, sexual orientation and/or religion in its business and hiring practices and that all of its employees are lawfully employed under all applicable federal, state and local laws, rules and regulations. (See Bid Form 2.)
18. This project is also subject to the requirements of the Rhode Island Drinking Water State Revolving Fund (DWSRF) Assistance Agreements, as administered by the Environmental Protection Agency (EPA) including but not limited to American Iron and Steel (AIS), Build America Buy America Act (BABAA), and Disadvantaged Business Enterprise (DBE) requirements. **DBE participation for this project is 10%.** DBE participation can be applied to the City of Providence MBE/WBE requirement.



**BOARD OF CONTRACT AND SUPPLY
CITY OF PROVIDENCE, RHODE ISLAND**

BID TERMS

1. Financial assurances may be required in order to be a successful bidder for Commodity or Construction and Service contracts. If either of the first two checkboxes below is checked, the specified assurance must accompany a bid, or the bid will not be considered by the Board of Contract and Supply. The third checkbox indicates the lowest responsible bidder will be contacted and required to post a bond to be awarded the contract.
 - a) A certified check for \$_____ must be deposited with the City Clerk as a guarantee that the Contract will be signed and delivered by the bidder.
 - b) A bid bond in the amount of **5** per centum (%) of the proposed total price, must be deposited with the City Clerk as a guarantee that the contract will be signed and delivered by the bidder; and the amount of such bid bond shall be retained for the use of the City as liquidated damages in case of default. Any person signing a bid bond as an attorney-in-fact shall include with the bid bond an original, or a photocopy or facsimile of an original, power of attorney.
 - c) A performance and payment bond with a satisfactory surety company will be posted by the bidder in a sum equal to twenty-five per centum (25%) of the awarded contract.
 - d) No financial assurance is necessary for this item.
2. Awards will be made within **ninety (90) days of bid opening**. All bid prices will be considered firm, unless qualified otherwise. Requests for price increases will not be honored.
3. Failure to deliver within the time quoted or failure to meet specifications may result in default in accordance with the general specifications. It is agreed that deliveries and/or completion are subject to strikes, lockouts, accidents, and Acts of God.

The following entry applies only for COMMODITY BID TERMS:

4. Payment for partial delivery will not be allowed except when provided for in blanket or term contracts.

The following entries apply only for CONSTRUCTION AND SERVICE BID TERMS:

5. Only one shipping charge will be applied in the event of partial deliveries for blanket or term contracts.
6. Prior to commencing performance under the contract, the successful bidder shall attest to compliance with the provisions of the Rhode Island Worker's Compensation Act, [RIGL 28-29-1, et seq.](#) If exempt from compliance, the successful bidder shall submit a sworn Affidavit by a corporate officer to that effect, which shall accompany the signed contract.
7. Prior to commencing performance under the contract, the successful bidder shall, submit a certificate of insurance, in a form and in an amount satisfactory to the City.



**BOARD OF CONTRACT AND SUPPLY
CITY OF PROVIDENCE, RHODE ISLAND**

BID FORM 1: Bidders Blank

1. Bids must meet the attached specifications. Any exceptions or modifications must be noted and fully explained.
2. Bidder's responses must be in ink or typewritten, and all blanks on the bid form should be completed.
3. The price or prices proposed should be stated both in **WRITING** and in **FIGURES**, and any proposal not so stated may be rejected. **Contracts exceeding twelve months must specify annual costs for each year.**
4. Bids **SHOULD BE TOTALED** so that the final cost is clearly stated (unless submitting a unit price bid), however **each item should be priced individually**. Do not group items. Awards may be made on the basis of *total* bid or by *individual items*.
5. All bids **MUST BE SIGNED IN INK.**

Name of Bidder (Firm or Individual): _____

Contact Name: _____

Business Address: _____

Business Phone #: _____

Contact Email Address: _____

Agrees to bid on (Write the "Item Description" here): **ACCELERATED LEAD SERVICE LINE REPLACEMENT PROGRAM – CONTRACT 1.4**

If the bidder's company is based in a state *other than Rhode Island*, list name and contact information for a local agent for service of process that *is located within Rhode Island*

Delivery Date (if applicable): _____

Name of Surety Company (if applicable): _____

Total Amount in Writing*: _____

Total Amount in Figures*: _____

****If you are submitting a unit price bid, please insert "Unit Price Bid"***

Use additional pages if necessary for additional bidding details.

- Bidder Certification, Performance of Work
- Acknowledge receipt of all Addenda to the Specifications
- Conforms to Specifications
- Modifications to Specifications. If yes, please note
- Required and Completed MBE/WBE Forms submitted with Bid
- Required and Completed EPA DBE Forms submitted with Bid

Signature of Representation

Title



**BOARD OF CONTRACT AND SUPPLY
CITY OF PROVIDENCE, RHODE ISLAND**

BID FORM 2: Certification of Bidder
(Non-Discrimination/Hiring)

Upon behalf of _____ (Firm or Individual Bidding),

I, _____ (Name of Person Making Certification),

being its _____ (Title or "Self"), hereby certify that:

1. Bidder does not unlawfully discriminate on the basis of race, color, national origin, gender, sexual orientation and/or religion in its business and hiring practices.
2. All of Bidder's employees have been hired in compliance with all applicable federal, state and local laws, rules and regulations.

I affirm by signing below that I am duly authorized on behalf of Bidder, on
this _____ day of _____, 20_____.

Signature of Representation

Printed Name



**BOARD OF CONTRACT AND SUPPLY
CITY OF PROVIDENCE, RHODE ISLAND**

BID FORM 3: Certificate Regarding Public Records

Upon behalf of _____ (Firm or Individual Bidding),

I, _____ (Name of Person Making Certification),

being its _____ (Title or "Self"), hereby certify an

understanding that:

1. All bids submitted in response to Requests for Proposals (RFP's) and Requests for Qualification (RFQ's), documents contained within, and the details outlined on those documents become public record upon receipt by the City Clerk's office and opening at the corresponding Board of Contract and Supply (BOCS) meeting.
2. The Purchasing Department and the issuing department for this RFP/RFQ have made a conscious effort to request that sensitive/personal information be submitted directly to the issuing department and only at request if verification of specific details is critical the evaluation of a vendor's bid.
3. The requested supplemental information may be crucial to evaluating bids. Failure to provide such details may result in disqualification, or an inability to appropriately evaluate bids.
4. If sensitive information that has not been requested is enclosed or if a bidder opts to enclose the defined supplemental information prior to the issuing department's request in the bidding packet submitted to the City Clerk, the City of Providence has no obligation to redact those details and bears no liability associated with the information becoming public record.
5. The City of Providence observes a public and transparent bidding process. Information required in the bidding packet may not be submitted directly to the issuing department at the discretion of the bidder in order to protect other information, such as pricing terms, from becoming public. Bidders who make such an attempt will be disqualified.

I affirm by signing below that I am duly authorized on behalf of Bidder, on

this _____ day of _____ 20_____.

Signature of Representation

Printed Name



**BOARD OF CONTRACT AND SUPPLY
CITY OF PROVIDENCE, RHODE ISLAND**

BID FORM 4: Affidavit of City Vendor

Per our Code of Ordinances [Sec. 21.-28.1 \(e\)](#), this form applies to a) the business, b) any political action committee whose name includes the name of the business, c) all persons holding ten (10) percent or greater equity interest or five thousand dollars (\$5,000.00) or greater cash value interest in the business at any time during the reporting period, d) all executive officers of the business entity, e) any spouse or dependent child of any individual identified in a) through d) above.

Executive officers who are not residents of the state of Rhode Island are exempted from this requirement.

Per [R.I.G.L. § 36-14-2](#), "Business" means a sole proprietorship, partnership, firm, corporation, holding company, joint stock company, receivership, trust, or any other entity recognized in law through which business for profit or not for profit is conducted .

Name of the person making this affidavit: _____

Position in the "Business" _____

Name of Entity _____

Address: _____

Phone number: _____

The number of persons or entities in your entity that are required to report under [Sec. 21.-28.1 \(e\)](#): _____

Read the following paragraph and answer one of the options:

Within the 12 month period preceding the date of this bid submission with the City of Providence, or with respect to the contracts that are not in writing within the 12 month period preceding the date of notification that the contract has reached the \$100,000 threshold, have you made campaign contributions within a calendar year to (please list all persons or entities required under [Sec. 21.-28.1 \(e\)](#)).

a. Members of the Providence City Council? Yes No

- If Yes, please complete the following:

Recipient(s) of the Contribution:

Contribution Date(s):

Contribution Amount(s):

b. Candidates for election or reelection to the Providence City Council? Yes No

- If Yes, please complete the following:

Recipient(s) of the Contribution:

Contribution Date(s):

Contribution Amount(s):



**BOARD OF CONTRACT AND SUPPLY
CITY OF PROVIDENCE, RHODE ISLAND**

c. The Mayor of Providence? Yes No

- If Yes, please complete the following:

Recipient(s) of the Contribution:

Contribution Date(s):

Contribution Amount(s):

d. Candidates for election or reelection to the office of Mayor of Providence? Yes No

- If Yes, please complete the following:

Recipient(s) of the Contribution:

Contribution Date(s):

Contribution Amount(s):

Signed under the pains and penalties of perjury.

Position



BID FORM 5: Bidder Certification, Performance of Work

Upon behalf of _____ (Firm or Individual Bidding),
I, _____ (Name of Person Making Certification),
being its _____ (Title or "Self"), hereby certify an understanding that:

Bidder conforms to the requirements as set forth in Section 00 21 13 – Instructions to Bidders, Article 2 – Qualifications of Bidders.

I affirm by signing below that I am duly authorized on behalf of Bidder, on
this _____ day of _____ 20_____.

Signature of Representation

Printed Name



**BOARD OF CONTRACT AND SUPPLY
CITY OF PROVIDENCE, RHODE ISLAND**

MBE/WBE Participation Plan

Please complete separate forms for each MBE/WBE subcontractor/supplier to be utilized on the solicitation.

Bidder's Name:				
Bidder's Address:				
Point of Contact:				
Telephone:				
Email:				
Procurement #:				
Project Name:				
Which one of the following describes your business' status in terms of Minority and/or Woman Owned Business Enterprise certification with the State of Rhode Island? (Check all that apply).	<input type="checkbox"/> MBE <input type="checkbox"/> WBE <input type="checkbox"/> Neither MBE nor WBE			
<p>This form is intended to capture commitments between the prime contractor/vendor and MBE/WBE subcontractors and suppliers, including a description of the work to be performed and the percentage of the work as submitted to the prime contractor/vendor. Please note that all MBE/WBE subcontractors/suppliers must be certified by the Office of Diversity, Equity and Opportunity at the time of bid. The MBE/WBE Directory can be found here. Please visit, the City's MBE/WBE page for details of the program (e.g. instructions and requirements).</p> <ul style="list-style-type: none"> Nonprofit organizations are not required to complete the rest of this form. Construction projects unable to identify subcontractors prior to bid submission (e.g. Design Build) are required to provide updates to the MBE/WBE Outreach Office 				
Name of Subcontractor/Supplier:				
Type of RI Certification:	<input type="checkbox"/> MBE <input type="checkbox"/> WBE <input type="checkbox"/> Neither			
Address:				
Point of Contact:				
Telephone:				
Email:				
Detailed Description of Work to Be Performed by Subcontractor or Materials to be Supplied by Supplier Per the Scope of Work provided in the RFP				
Total Contract Value (\$):		Subcontract Value (\$):		Participation Rate (%):
Anticipated Date of Performance:				
I certify under penalty of perjury that the forgoing statements are true and correct.				
Prime Contractor/Vendor Signature	Title			Date
Subcontractor/Supplier Signature	Title			Date

***If you did not meet the 20% MBE/WBE combined participation goal, submit a Waiver Request Form.**



**BOARD OF CONTRACT AND SUPPLY
CITY OF PROVIDENCE, RHODE ISLAND**

MBE/WBE Waiver Request Form

Fill out this form only if you did not meet the 20% MBE/WBE participation goal.
State-certified MBE or WBE Prime Bidders are NOT REQUIRED to fill out this form.

Submit this form to the City of Providence MBE/WBE Outreach Director, Grace Diaz, at gdiaz@providenceri.gov, for review **prior to bid submission**. This waiver applies only to the current bid which you are submitting to the City of Providence and does not apply to other bids your company may submit in the future. **In case a waiver is needed, City Department Directors should not recommend a bidder for an award if this form is not included, absent or is not signed by the city of Providence MBE/WBE director.**

Prime Bidder: _____ Contact Email and Phone _____
Company Name, Address: _____ Trade _____
Project /Item Description (as seen on RFP): _____

To receive a waiver, you must list the certified MBE and/or WBE companies you contacted, the name of the primary individual with whom you interacted, and the reason the MBE/WBE company could not participate on this project.

MBE/WBE Company Name	Individual's Name	Company Name	Why did you choose not to work with this company?

I acknowledge the City of Providence's goal of a combined MBE/WBE participation is 20% of the total bid value. I am requesting a waiver of _____% MBE/WBE (20% minus the value of **Box F** on the Subcontractor Disclosure Form). If an opportunity is identified to subcontract any task associated with the fulfillment of this contract, a good faith effort will be made to select MBE/WBE certified businesses as partners.

Signature of Prime Contractor /
or Duly Authorized Representative

Printed Name

Date Signed

Signature of City of Providence
MBE/WBE Outreach Director /
or Duly Authorized Representative

Printed Name of City of Providence
MBE/WBE Outreach Director

Date Signed



**BOARD OF CONTRACT AND SUPPLY
CITY OF PROVIDENCE, RHODE ISLAND**

BID PACKAGE SPECIFICATIONS

Overview

See Summary of Work, Section 01010.

Scope of Work

See Summary of Work, Section 01010.

Proposed Schedule

See Contract Specifications.

Evaluation Criteria

See Instructions to Bidders, Section 002113.



**BOARD OF CONTRACT AND SUPPLY
CITY OF PROVIDENCE, RHODE ISLAND**

EPA DBE Program Form Instructions

The work of this Contract is in part funded by the U.S. Environmental Protection Agency (EPA) and the State of Rhode Island Drinking Water State Revolving Fund (DWSRF) pursuant to the Safe Drinking Water Act Amendments of 1996 (SDWA) and as included in Appendix K. The work of this Contract shall comply with EPA's Disadvantaged Business Enterprise (DBE) Program under the provision of 40 CFR, Part 33. Program requirements are provided at <https://www.epa.gov/grants/disadvantaged-business-enterprise-program-requirements> and as included in Appendix K.

Providence Water has committed to a 10% DBE participation requirement, which may overlap with the City of Providence's MBE/WBE participation goal. **A waiver will not be granted for the 10% DBE requirement.**

DBE forms must be completed for EACH bid submitted and must be inclusive of ALL required signatures. Forms without all required signatures will be considered incomplete.

**U.S. Environmental Protection Agency (EPA)
Disadvantaged Business Enterprise (DBE) Program**

GOOD FAITH EFFORTS

EPA DBE SUBCONTRACTOR FORMS

EPA Form 6100-2 (required during contract execution)

EPA Form 6100-3 (complete and submit with Bid)

EPA Form 6100-4 (complete and submit with Bid)

Good Faith Efforts

What is the Purpose of the Good Faith Efforts?

The Good Faith Efforts are methods employed by all EPA financial assistance agreement recipients to ensure that disadvantaged business enterprises (DBEs) have the opportunity to compete for procurements funded by EPA financial assistance funds.

What Are the Good Faith Efforts?

- ❖ Ensure DBEs are made aware of contracting opportunities to the fullest extent practicable through outreach and recruitment activities. For Indian Tribal, State and local government recipients, this will include placing DBEs on solicitation lists and soliciting them whenever they are potential sources.
- ❖ Make information on forthcoming opportunities available to DBEs and arrange time frames for contracts and establish delivery schedules, where the requirements permit, in a way that encourages and facilitates participation by DBEs in the competitive process. This includes, whenever possible, posting solicitations for bids or proposals for a minimum of 30 calendar days before the bid or proposal closing date.
- ❖ Consider in the contracting process whether firms competing for large contracts could subcontract with DBEs. For Indian Tribal, State and local Government recipients, this will include dividing total requirements, when economically feasible, into smaller tasks or quantities to permit maximum participation by DBEs in the competitive process.
- ❖ Encourage contracting with a consortium of DBEs when a contract is too large for one of these firms to handle individually.
- ❖ Use the services and assistance of the SBA and the Minority Business Development Agency of the Department of Commerce.
- ❖ If the prime contractor awards subcontracts, require the prime contractor to take the steps in paragraphs (a) through (e) of this section.

What are the New Contract Administration Provisions?

When the DBE rule goes into effect, there are a number of new provisions designed to prevent unfair practices that adversely affect DBEs. Those provisions are as follows:

- ❖ A recipient must require its prime contractor to pay its subcontractor for satisfactory performance no more than 30 days from the prime contractor's receipt of payment from the recipient.
- ❖ A recipient must be notified in writing by its prime contractor prior to any

termination of a DBE subcontractor for convenience by the prime contractor.

- ❖ If a DBE subcontractor fails to complete work under the subcontract for any reason, the recipient must require the prime contractor to employ the Six Good Faith Efforts if soliciting a replacement subcontractor.
- ❖ A recipient must require its prime contractor to employ the Six Good Faith Efforts even if the prime contractor has achieved its fair share objectives.

What are the New Forms Associated With the New Contract Administration Provisions?

EPA Form 6100-2 - DBE Program Subcontractor Participation Form. This form gives a DBE subcontractor the opportunity to describe the work the DBE subcontractor received from the prime contractor, how much the DBE subcontractor was paid and any other concerns the DBE subcontractor might have.

EPA Form 6100-3 - DBE Program Subcontractor Performance Form. This form captures an intended subcontractor's description of work to be performed for the prime contractor and the price of the work submitted to the prime.

EPA Form 6100-4 – DBE Program Subcontractor Utilization Form. This form captures the prime's intended use of an identified DBE subcontractor, and the estimated dollar amount of the subcontract.

Form	Requirement	Provided By	Completed By	Submitted To
EPA Form 6100-2	Recipients required to have prime contractors provide form to Subcontractors	Prime Contractors	DBE Subcontractors	EPA DBE Coordinator
EPA Form 6100-3	Recipients required to have prime contractors provide form to Subcontractors	Prime Contractors	DBE Subcontractors	Recipients as part of bid or proposal package
EPA Form 6100-4	Recipients required to have prime contractors complete the form	Recipients	Prime Contractors	Recipients as part of bid or proposal package



UNITED STATES ENVIRONMENTAL PROTECTION AGENCY
WASHINGTON, D.C. 20460

MAR 8 2016

OFFICE OF
SMALL BUSINESS
PROGRAMS

MEMORANDUM

SUBJECT: Suspended Use of Forms Associated with Disadvantaged Business Enterprise Participation in Financial Assistance Agreements

FROM: Kimberly Y. Patrick, Director
Office of Small Business Programs

A handwritten signature in black ink, appearing to be "KYP", written over the printed name of Kimberly Y. Patrick.

Teree Henderson, DBE Program National Coordinator
Office of Small Business Programs

TO: EPA Financial Assistance Agreement Recipients, Prime Contractors and DBE Subcontractors

As of March 7, 2016, EPA has suspended use of the following forms associated with the DBE Rule pursuant to 40 CFR 33:

CONTRACT ADMINISTRATION

- EPA Form 6100-2, DBE Subcontractor Participation Form;
- EPA Form 6100-3, DBE Subcontractor Performance Form; and
- EPA Form 6100-4, DBE Subcontractor Utilization Form

CERTIFICATION APPLICATIONS

- EPA Form 6100-1a, Sole Proprietorship;
- EPA Form 6100-1b, Limited Liability Company;
- EPA 6100-1c, Partnerships;
- EPA Form 6100-1d, Corporations;
- EPA Form 6100-1e, Alaska Native Corporations;
- EPA Form 6100-1f, Tribally Owned Businesses;
- EPA Form 6100-1g, Private and Voluntary Organizations;
- EPA Form 6100-1h, Concerns Owned by Native Hawaiian Organizations; and
- EPA Form 6100-1i, Concerns Owned by Community Development Corporations

EPA is currently making revisions to the DBE Rule which will affect use of the above-mentioned forms and as a result, use of the forms have been postponed until further notice. EPA financial assistance agreement recipients who initiated procurements prior to March 7, 2016 are expected to require use of EPA Forms 6100-3 and 6100-4. The optional use of EPA Form 6100-2 is also valid for procurements initiated prior to March 7, 2016. Recipients who initiate procurements after March 7, 2016 cannot require the use of these forms. Entities seeking EPA DBE certification should contact Teree Henderson at henderson.teree@epa.gov for further instruction.

Please note that while use of the aforementioned forms has been suspended, the remaining requirements under 40 CFR 33 are still in effect; this includes, but is not limited to: the Good Faith Efforts (Subpart C), the Fair Share Objectives (Subpart D), and Recordkeeping and Reporting (Subpart E). EPA financial assistance agreement recipients, prime contractors and DBE subcontractors are expected to make every effort to continue to uphold the intent of the DBE Program.

The process to improve the DBE Rule is underway. During this process there will be notices posted in the Federal Register soliciting your comments and feedback. We encourage you to provide suggestions during this time. If you have any questions, please contact your Regional Small Business Coordinator, or Teree Henderson, DBE Program National Coordinator, at 202-566-2222.

cc: Regional Small Business Coordinators
Office of Grants and Debarment

Providence Water requires the submittal of the following forms with the bid documents:

EPA Form 6100-3 DBE Subcontractor Performance Form
EPA Form 6100-4 DBE Subcontractor Utilization Form

**Disadvantaged Business Enterprise (DBE) Program
DBE Subcontractor Participation Form**

An EPA Financial Assistance Agreement Recipient must require its prime contractors to provide this form to its DBE subcontractors. This form gives a DBE¹ subcontractor² the opportunity to describe work received and/or report any concerns regarding the EPA-funded project (e.g., in areas such as termination by prime contractor, late payments, etc.). The DBE subcontractor can, as an option, complete and submit this form to the EPA DBE Coordinator at any time during the project period of performance.

Subcontractor Name		Project Name	
Bid/ Proposal No.	Assistance Agreement ID No. (if known)	Point of Contact	
Address			
Telephone No.		Email Address	
Prime Contractor Name		Issuing/Funding Entity:	

Contract Item Number	Description of Work Received from the Prime Contractor Involving Construction, Services , Equipment or Supplies	Amount Received by Prime Contractor

¹ A DBE is a Disadvantaged, Minority, or Woman Business Enterprise that has been certified by an entity from which EPA accepts certifications as described in 40 CFR 33.204-33.205 or certified by EPA. EPA accepts certifications from entities that meet or exceed EPA certification standards as described in 40 CFR 33.202.

² Subcontractor is defined as a company, firm, joint venture, or individual who enters into an agreement with a contractor to provide services pursuant to an EPA award of financial assistance.

**Disadvantaged Business Enterprise (DBE) Program
DBE Subcontractor Performance Form**

This form is intended to capture the DBE¹ subcontractor's² description of work to be performed and the price of the work submitted to the prime contractor. An EPA Financial Assistance Agreement Recipient must require its prime contractor to have its DBE subcontractors complete this form and include all completed forms in the prime contractor's bid or proposal package.

Subcontractor Name		Project Name	
Bid/ Proposal No.	Assistance Agreement ID No. (if known)	Point of Contact	
Address			
Telephone No.		Email Address	
Prime Contractor Name		Issuing/Funding Entity:	

Contract Item Number	Description of Work Submitted to the Prime Contractor Involving Construction, Services, Equipment or Supplies	Price of Work Submitted to the Prime Contractor
DBE Certified By: ___ DOT ___ SBA ___ Other: _____		Meets/ exceeds EPA certification standards? ___ YES ___ NO ___ Unknown

¹ A DBE is a Disadvantaged, Minority, or Woman Business Enterprise that has been certified by an entity from which EPA accepts certifications as described in 40 CFR 33.204-33.205 or certified by EPA. EPA accepts certifications from entities that meet or exceed EPA certification standards as described in 40 CFR 33.202.

² Subcontractor is defined as a company, firm, joint venture, or individual who enters into an agreement with a contractor to provide services pursuant to an EPA award of financial assistance.

**Disadvantaged Business Enterprise (DBE) Program
DBE Subcontractor Performance Form**

I certify under penalty of perjury that the forgoing statements are true and correct. Signing this form does not signify a commitment to utilize the subcontractors above. I am aware of that in the event of a replacement of a subcontractor, I will adhere to the replacement requirements set forth in 40 CFR Part 33 Section 33.302 (c).

Prime Contractor Signature	Print Name
Title	Date

Subcontractor Signature	Print Name
Title	Date

The public reporting and recordkeeping burden for this collection of information is estimated to average three (3) hours per response. Send comments on the Agency's need for this information, the accuracy of the provided burden estimates, and any suggested methods for minimizing respondent burden, including through the use of automated collection techniques to the Director, Collection Strategies Division, U.S. Environmental Protection Agency (2822T), 1200 Pennsylvania Ave., NW, Washington, D.C. 20460. Include the OMB control number in any correspondence. Do not send the completed form to this address.

Disadvantaged Business Enterprise (DBE) Program DBE Subcontractor Utilization Form

This form is intended to capture the prime contractor's actual and/or anticipated use of identified certified DBE¹ subcontractors² and the estimated dollar amount of each subcontract. An EPA Financial Assistance Agreement Recipient must require its prime contractors to complete this form and include it in the bid or proposal package. Prime contractors should also maintain a copy of this form on file.

Prime Contractor Name		Project Name	
Bid/ Proposal No.	Assistance Agreement ID No. (if known)	Point of Contact	
Address			
Telephone No.		Email Address	
Issuing/Funding Entity:			

I have identified potential DBE certified subcontractors	__ YES	__ NO	
If yes, please complete the table below. If no, please explain:			
Subcontractor Name/ Company Name	Company Address/ Phone/ Email	Est. Dollar Amt	Currently DBE Certified?

Continue on back if needed

¹ A DBE is a Disadvantaged, Minority, or Woman Business Enterprise that has been certified by an entity from which EPA accepts certifications as described in 40 CFR 33.204-33.205 or certified by EPA. EPA accepts certifications from entities that meet or exceed EPA certification standards as described in 40 CFR 33.202.

² Subcontractor is defined as a company, firm, joint venture, or individual who enters into an agreement with a contractor to provide services pursuant to an EPA award of financial assistance.

**Disadvantaged Business Enterprise (DBE) Program
DBE Subcontractor Utilization Form**

I certify under penalty of perjury that the forgoing statements are true and correct. Signing this form does not signify a commitment to utilize the subcontractors above. I am aware of that in the event of a replacement of a subcontractor, I will adhere to the replacement requirements set forth in 40 CFR Part 33 Section 33.302 (c).

Prime Contractor Signature	Print Name
Title	Date

The public reporting and recordkeeping burden for this collection of information is estimated to average three (3) hours per response. Send comments on the Agency's need for this information, the accuracy of the provided burden estimates, and any suggested methods for minimizing respondent burden, including through the use of automated collection techniques to the Director, Collection Strategies Division, U.S. Environmental Protection Agency (2822T), 1200 Pennsylvania Ave., NW, Washington, D.C. 20460. Include the OMB control number in any correspondence. Do not send the completed form to this address.



SUPPLEMENTAL INFORMATION

If the issuing department for this RFP determines that your firm's bid is best suited to accommodate their need, you will be asked to provide proof of the following prior to formalizing an award.

An inability to provide the outlined items at the request of the department may lead to the disqualification of your bid.

*This information is **NOT** requested to be provided in your initial bid that you will submit to the City Clerk's office by the "date to be opened" noted on page 1. This list only serves as a list of items that your firm should be ready to provide on request.*

All bids submitted to the City Clerk become public record. Failure to follow instructions could result in information considered private being posted to the city's Open Meetings Portal and made available as a public record.

You must be able to provide:

- Business Tax ID will be requested after an award is approved by the Board of Contract and Supply.
- Proof of Insurance.
- Certificate of Good Standing with the Rhode Island Secretary of State.
- Bidders shall provide all required supplemental documents and information as specified in the Bidding/Contract Documents.



**BOARD OF CONTRACT AND SUPPLY
CITY OF PROVIDENCE, RHODE ISLAND**

CITY OF PROVIDENCE STANDARD TERMS & CONDITIONS

1. The terms “you” and “your” contained herein refer to the person or entity that is a party to the agreement with the City of Providence (“the City”) and to such person’s or entity’s employees, officers, and agents.
2. The Request For Proposals (“RFP”) and these Standard Terms and Conditions together constitute the entire agreement of the parties (“the Agreement”) with regard to any and all matters. By your submission of a bid proposal or response to the City’s RFP, you accept these Standard Terms & Conditions and agree that they supersede any conflicting provisions provided by bid or in any terms and conditions contained or linked within a bid and/or response. Changes in the terms and conditions of the Agreement, or the scope of work thereunder, may only be made by a writing signed by the parties.
3. You are an independent contractor and in no way does this Agreement render you an employee or agent of the City or entitle you to fringe benefits, workers’ compensation, pension obligations, retirement or any other employment benefits. The City shall not deduct federal or state income taxes, social security or Medicare withholdings, or any other taxes required to be deducted by an employer, and this is your responsibility to yourself and your employees and agents.
4. You shall not assign your rights and obligations under this Agreement without the prior written consent of the City. Any assignment without prior written consent of the City shall be voidable at the election of the City. The City retains the right to refuse any and all assignments in the City’s sole and absolute discretion.
5. Invoices submitted to the City shall be payable sixty (60) days from the time of receipt by the City. Invoices shall include support documentation necessary to evidence completion of the work being invoiced. The City may request any other reasonable documentation in support of an invoice. The time for payment shall not commence, and invoices shall not be processed for payment, until you provide reasonably sufficient support documentation. In no circumstances shall the City be obligated to pay or shall you be entitled to receive interest on any overdue invoice or payment. In no circumstances shall the City be obligated to pay any costs associated with your collection of an outstanding invoice.
6. For contracts involving construction, alteration, and/or repair work, the provisions of applicable state labor law concerning payment of prevailing wage rates (R.I. Gen. Laws §§ 37-13-1 et seq., as amended) and the City’s First Source Ordinance (Providence Code of Ordinances §§ 21-91 et seq., as amended) apply.
7. With regard to any issues, claims, or controversies that may arise under this Agreement, the City shall not be required to submit to dispute resolution or mandatory/binding arbitration. Nothing prevents the parties from mutually agreeing to settle any disputes using mediation or non-binding arbitration.
8. To the fullest extent permitted by law, you shall indemnify, defend, and hold harmless the City, its employees, officers, agents, and assigns from and against any and all claims, damages, losses, allegations, demands, actions, causes of action, suits, obligations, fines, penalties, judgments, liabilities, costs and expenses, including but not limited to attorneys’ fees, of any nature whatsoever arising out of, in connection with, or resulting from the performance of the work provided in the Agreement.
9. You shall maintain throughout the term of this Agreement the insurance coverage that is required by the RFP or, if none is required in the RFP, insurance coverage that is considered in your industry to be commercially reasonable, and you agree to name the City as an additional insured on your general liability policy and on any umbrella policy you carry.
10. The City shall not subject itself to any contractual limitations on liability. The City shall have the time permitted within the applicable statute of limitations, and no less, to bring or assert any and all causes of action, suits, claims or demands the City may have arising out of, in connection with, or resulting from the performance of the work provided in the Agreement, and in no event does the City agree to limit your liability to the price of the Agreement or any other monetary limit.
11. The City may terminate this Agreement upon five (5) days’ written notice to you if you fail to observe any of the terms and conditions of this Agreement, or if the City believes your ability to perform the



**BOARD OF CONTRACT AND SUPPLY
CITY OF PROVIDENCE, RHODE ISLAND**

terms and conditions of this Agreement has been materially impaired in any way, including but in no way limited to loss of insurance coverage, lapsing of a surety bond, if required, declaration of bankruptcy, or appointment of a receiver. In the event of termination by the City, you shall be entitled to just and equitable compensation for any satisfactory work completed and expenses incurred up to the date of termination.

12. Written notice hereunder shall be deemed to have been duly served if delivered in person to the individual or member of the firm or entity or to an officer of the entity for whom it was intended, or if delivered at or sent by registered or certified mail to the last business address known by the party providing notice.
13. In no event shall the Agreement automatically renew or be extended without a writing signed by the parties.
14. You agree that products produced or resulting from the performance of the Agreement are the sole property of the City and may not be used by you without the express written permission of the City.
15. For any Agreement involving the sharing or exchange of data involving potentially confidential and/or personal information, you shall comply with any and all state and/or federal laws or regulations applicable to confidential and/or personal information you receive from the City, including but not limited to the Rhode Island Identity Theft Protection Act, R.I. Gen. Laws § 11-49.3-1, during the term of the Agreement. You shall implement and maintain appropriate physical, technical, and administrative security measures for the protection of, and to prevent access to, use, or disclosure of, confidential and/or personal information. In the event of a breach of such information, you shall notify the City of such breach immediately, but in no event later than twenty-four (24) hours after discovery of such breach.
16. The Agreement is governed by the laws of the State of Rhode Island. You expressly submit yourself to and agree that any and all actions arising out of, in connection with, or resulting from the performance of the Agreement or relationship between the parties shall occur solely in the venue and jurisdiction of the State of Rhode Island or the federal court located in Rhode Island.
17. The failure of the City to require performance of any provision shall not affect the City's right to

require performance at any time thereafter, nor shall a waiver of any breach or default of this Agreement constitute a waiver of any subsequent breach or default or a waiver of the provision itself.

18. If any term or provision of this Agreement, or the application thereof to any person or circumstance shall, in any extent, be invalid or unenforceable, the remainder of this Agreement shall not be affected thereby, and each term and provision shall be valid and enforceable to the fullest extent permitted by law.



**PROVIDENCE WATER
ACCELERATED LEAD SERVICE LINE REPLACEMENT PROGRAM (CONTRACT 1.4)
PROJECT NO. 20234**

INVITATION TO BID

On behalf of the Providence Water Supply Board (Owner), the City of Providence and its Board of Contract and Supply is accepting Sealed Bids for construction of the Accelerated Lead Service Line Replacement Program – Contract 1.4. Sealed Bids will be received by the City of Providence Board of Contract and Supply at the location and until the date and time indicated in the City of Providence, Rhode Island Board of Contract and Supply Request for Proposals included in these Specifications, and at that time bids will be publicly opened and read aloud.

The Work of this Project generally includes replacing lead service lines within the Owner's retail water service area in the Cities of Providence and Cranston, Rhode Island. Bidders are requested to provide unit rate bid prices for replacing public and private side lead service lines (water main to curb stop and/or curb stop to water meter) and other items associated with lead service line replacements, along with their qualifications to perform the Work of replacing lead service lines. The intent of this Project is that the Owner will make an award to one contractor based on meeting the required qualifications specified herein and based on evaluation of the submitted bid prices.

The Work of this Project generally consists of replacing existing lead service lines at approximately 1,219 locations involving full replacements (public (water main to curb stop) and private (curb stop to water meter) side), public side only (water main to curb stop) replacements, and private side only (curb stop to the water meter) replacements. This work shall include, but is not limited to, replacing existing lead service lines with new corporation stops, curb stops, curb boxes, copper service tubing, adapters and fittings, connecting new private service lines to curb stops and water meters in buildings and performing all Work in accordance with all applicable codes, all necessary appurtenances and incidentals, all required surface restoration, and all other related and incidental work required and as specified for the successful completion of the Work and Project. The construction methods will be trenchless, pulling, or, when specified at the direction of the Owner, open cut. The Contractor shall provide all materials, equipment, tools, labor, services, appurtenances, and incidentals to complete all Work as required and as specified. All work on private property is contingent upon approval by each respective property owner and signed agreements between the individual property owners and Owner (Providence Water).

The Contract Time for this Project shall be as indicated in the City of Providence, Rhode Island Board of Contract and Supply Request for Proposals included in these Specifications, commencing as specified in the Standard General Conditions of the Construction Contract, as amended and/or modified by the Supplementary Conditions.

To obtain and/or examine Contract Documents, including any required deposits and fees for obtaining Contract Documents, refer to the City of Providence, Rhode Island Board of Contract and Supply Request for Proposals included in these Specifications.

Details for any pre-bid conference, where representatives of the Owner will review and discuss the Project and Work, are included in the City of Providence, Rhode Island Board of Contract and Supply Request for Proposals included in these Specifications.



Each Bid shall be submitted in accordance with the City of Providence, Rhode Island Board of Contract and Supply Request for Proposals included in these Specifications and the Instructions to Bidders and shall be accompanied by a Bid Security in an amount as specified.

Bidders may not withdraw their Bids for a period of 60 days after the actual date of the opening of the Bids.

The Successful Bidder must furnish a Performance Bond and Payment Bond, as specified in the City of Providence, Rhode Island Board of Contract and Supply Request for Proposals included in these Specifications, with a surety company acceptable to the Owner, as well as all required Certificates of Insurance.

Complete instructions for filing Bids are included in the City of Providence, Rhode Island Board of Contract and Supply Request for Proposals and Instructions to Bidders.

The work of this Contract shall comply with the State of Rhode Island General Laws (RIGL) Chapter 37. Prevailing wage rates under the provision of RIGL Chapter 37-13 apply to this project in accordance with United States Department of Labor under the Davis-Bacon Act. RIGL Chapter 37-14.1, RIGL Chapter 37-2.2 and RICR 220-RICR-80-10-2 apply to this project.

This project is subject to the requirements of the Rhode Island Drinking Water State Revolving Fund (DWSRF) Program as administered by the Rhode Island Department of Health (RIDOH) Office of Drinking Water Quality. Reference is made to the RIDOH DWSRF Program requirements bound within the appendices of the Contract Specifications, which include but are not limited to the American Iron and Steel (AIS), Build America Buy America Act (BABAA), and Disadvantaged Business Enterprise (DBE) requirements. Bidders must complete and submit with their bids Disadvantaged Business Enterprise (DBE) participation forms as included in the Bid Documents with a participation requirement of 10%.

This agreement is for services related to a project that is subject to the Build America, Buy American Act (BABAA) requirements under Title IX of the Infrastructure Investment and Jobs Act ("IIJA"), Pub. L. 177-58. Absent an approved waiver, all iron, steel, manufactured products, and construction materials used in this project must be produced in the United States, as further outlined by the Office of Management and Budget's Memorandum M-22-11, Initial Implementation Guidance on Application of Buy America Preference in Federal Financial Assistance Programs for Infrastructure, April 18, 2022.

The Owner reserves the right to waive any informality in or to reject any or all Bids if deemed to be in its best interest.

PROVIDENCE WATER SUPPLY BOARD
CITY OF PROVIDENCE, RHODE ISLAND

**PROVIDENCE WATER
ACCELERATED LEAD SERVICE LINE REPLACEMENT PROGRAM – CONTRACT 1.4
PROJECT NO. 20234**

INSTRUCTIONS TO BIDDERS

ARTICLE 1. DEFINITIONS & TERMINOLOGY

- 1.1 Definitions and terms used in these Instructions to Bidders, Specifications, and Contract Documents will have the meanings defined in the Standard General Conditions of the Construction Contract and Supplementary Conditions of these Specifications.
- 1.2 Definitions and terms shall have the additional meanings indicated below, which are applicable to both the singular and plural thereof:
 - A. Contractor / General Contractor: The individual or entity with whom Owner enters into an Agreement to perform the Work of the Project.
 - B. Bidder: The individual, firm, or entity who submits a Bid to perform the Work of the Project as Contractor / General Contractor.
 - C. Issuing Office: The office issuing the Bidding Documents, the City of Providence Purchasing Department, Providence City Hall, 25 Dorrance Street, Providence, Rhode Island.
 - D. Owner: Providence Water Supply Board (Providence Water), the administrator of this Contract and Work of the Project, through and in conjunction with the City of Providence and its Board of Contract and Supply.
 - E. Owner's Representative: A representative designated and authorized by the Owner to act on the Owner's behalf with respect to the Contract, Project, and Work, who may include but not be limited to Advisors, Architectural and/or Engineering Consultants, Construction Managers, and/or Resident Project Representatives who are contracted by the Owner to represent and act on Owner's behalf.
 - F. Successful Bidder: The lowest qualified and responsible Bidder on the basis of the Base Bid plus all Supplementary Bid Items whose Bid is deemed to be responsible, eligible, responsive and is the lowest of those Bidders that possess the necessary skill, ability, experience, qualifications, and integrity necessary to the faithful performance of the Work and whose Bid represents the best value and is in the best interests of the Owner to whom Owner on the sole basis of Owner's evaluation makes an award for the Work. Once the lowest bidder is determined on the basis of the Base Bid plus all Supplementary Bid Items, the Owner may elect to exclude some of the Supplementary Bid Items based on funds available. The Supplementary Bid Items are at the discretion of the Owner and may not be included in the contract. Such a Bidder shall possess the skill, ability, and integrity necessary for the faithful performance of the work and shall meet the required minimum qualifications specified herein. The terms "lowest responsible and eligible Bidder" or "lowest qualified and responsible bidder" if used herein and elsewhere in the Contract Documents shall have the same meaning as "Successful Bidder".

- G. Work: Denotes any and all required activities under this Contract and Project, regardless of its nature.

ARTICLE 2. QUALIFICATIONS OF BIDDERS

2.1 General

- A. Bidders may be investigated by Owner to determine if they are qualified to perform the Work. In addition to the information required to be submitted with the Bid, all Bidders shall be prepared to submit within five days of Owner's request, written evidence of such additional information and data necessary to make this determination. Additional information may include, but is not limited to, experience, qualifications, references for past and other current work, performance on other projects, compliance with contract documents on other projects, compliance with required schedules on other work, health and safety performance, administrative and management performance, present work commitments, equipment available for this Work, financial data and capacity, bonding capacity and information, insurance information, information on previous claims against, and any and all other such data as Owner requests.
- B. The investigation of a Bidder will seek to determine whether the organization is adequate in size, is authorized to do business in the jurisdiction where the project is located, is qualified, has had previous experience and whether available equipment and financial resources are adequate to assure Owner that the Work will be completed in accordance with the terms of the Contract Agreement. The amount of other work to which the Bidder is committed may also be considered.
- C. In evaluating Bids, Owner will consider the qualifications of only those Bidders whose Bids are in compliance with the prescribed requirements.
- D. Bidders shall completely and truthfully respond to and provide all information requested by the Contract Documents and by the Owner. Failure of a Bidder to provide all requested information may, at the Owner's discretion, render a Bid being considered non-responsive and rejected.
- E. Owner requests Bids from Contractors that specialize in the water main construction and rehabilitation method(s) specified in the Contract Documents and that meet the minimum qualifications defined herein. It is the intent of these Contract Documents that that Bidder who submits a Bid as the Prime/General Contractor must meet the minimum qualification requirements specified herein for the project's specified water main construction and/or rehabilitation method. The Bid of a Bidder who does not meet the minimum qualification requirements will be considered non-responsive and will be rejected.
- F. Bidder shall provide information on the experience of the firm, the experience of the personnel who will oversee and perform the work, and on the equipment and materials (e.g., temporary bypass piping) to be used to perform the Work. The experience of personnel with any other contractor, company or firm does not qualify the Bidder; the experience to meet these qualifications must be with the Contractor bidding the project as Bidder. The Owner reserves the right to reject individual crew leaders and/or any

personnel due to inadequate experience or previous unsatisfactory or poor performance.

- G. Bidder must be able to field multiple crews at all times to accomplish the Work.
- H. Bidders must have experience working around congested underground utilities, coordinating with utility owners and agencies, and performing required temporary and subsequent final/permanent surface restoration on both public and private property.
- I. Bidder shall describe any work that will be subcontracted as required in Section 00 43 36 – Proposed Subcontractors and Suppliers.
- J. Owner reserves the right to reject any Bid if the evidence submitted by or the investigation of such Bidder fails to satisfy Owner that such Bidder is properly qualified and/or capable to carry out the obligations of the Contract Documents and to complete the Work specified therein.

2.2 Water Service Line Replacements and Installations

- A. Within the past ten (10) years, Bidder/Contractor and/or Subcontractors must have experience replacing at least 1,000 existing full (from water main to inside building) water service lines and lead water service lines and installing new service lines up to 2-inches in size, both in urban and rural areas and on public and private property, including tapping and extracting corporation stops; plugging existing taps; installing new corporation stops; replacing and installing new curb stops and boxes; installing new water service line tubing (including using trenchless construction techniques (e.g., pulling, moling, etc.); installing and connecting water service lines to water meters and plumbing inside buildings, including all associated adapters, fittings and appurtenances in accordance with required plumbing codes; performing associated temporary and permanent surface restoration (restoration of sidewalks, roads, and grass areas); and coordinating and scheduling work with property owners and residents. On the required Bidder Qualifications Forms to be submitted to the Owner with their Bid, each Bidder shall indicate the total number of water service line replacements that they have completed within the past ten (10) years and the city/town.

ARTICLE 3. COPIES OF CONTRACT DOCUMENTS

- 3.1 Complete sets of Contract Documents may be obtained as described in the City of Providence, Rhode Island Board of Contract and Supply Request for Proposals and the Invitation To Bid of these Specifications.
- 3.2 Complete sets of Contract Documents shall be used in preparing Bids; Owner does not assume any responsibility for errors or misinterpretations resulting from the use of incomplete sets of Contract Documents.
- 3.3 Owner in making copies of Contract Documents available does so only for the purpose of obtaining Bids on the Work and do not confer a license or grant for any other use.

ARTICLE 4. CONTRACT DOCUMENTS AND PROJECT SITE(S)

- 4.1 The Project Site(s) is/are identified in the Contract Documents. Additional areas or land and access thereto for temporary construction facilities, construction equipment, or storage of equipment and materials for the Work are to be obtained and paid for by the Contractor. Easements for permanent changes in existing facilities are to be obtained and paid for by the Owner unless otherwise provided in the Contract Documents.
- 4.2 Before submitting a Bid, each Bidder must (1) examine the Contract Documents thoroughly, (2) visit the site(s) to become familiar with local conditions that may in any manner affect cost, progress or performance of the Work, (3) become familiar with Federal, State and local laws, ordinances, rules and regulations that may in any manner affect cost, progress or performance of the Work; and (4) study and carefully correlate Bidder's observations with the requirements of the Contract Documents.
- 4.3 Surveys and investigative reports of subsurface or latent physical conditions at the site(s), if any, which have been relied upon by Owner in preparing the Contract Documents are identified in Article 5 of the Supplementary Conditions. Copies of these reports, if available, are included in the Appendices to the Project Manual. These reports are not guaranteed or warranted as to accuracy or completeness, nor are they part of the Contract Documents. Bidder is solely responsible for any interpretation or conclusion that Bidder makes from this information or any other data or information.
- 4.4 Unless otherwise stated in the Contract Documents or on the Drawings, existing site conditions depicted are not based on actual survey and may not show all existing utilities that may be present. Information on existing utilities shown on the Drawings, if any, is based upon information furnished to Owner by others. Owner makes no guarantee or warranty as to the accuracy or completeness of this information. Contractor is responsible for confirming the location of all underground utilities prior to the commencement of construction and prior to any excavation. Contractor is responsible for all underground utilities and structures, whether active or not, and shall continually communicate and coordinate with all respective utility companies and agencies. Contractor is solely responsible to repair any and all damage to existing utilities and structures at Contractor's own expense. Prior to any excavation work, Contractor must contact DigSafe and all utility agencies to mark out the location of underground utilities, structures, and facilities.
- 4.5 Before submitting a Bid, Bidders may, at their own expense, make such additional investigations and tests as they may deem necessary to determine their Bid for performance of the Work in accordance with the time, price and other terms and conditions of the Contract Documents.
- 4.6 Upon request, Owner will provide each Bidder access to the site(s) to conduct such examinations, investigations, explorations, studies, and tests as each Bidder deems necessary for the submission of a Bid. Bidder shall provide Owner with a minimum of 72 hours of notice for any such investigative work. For work on private property, Bidder shall contact Owner for access to the site(s). Bidder is not to contact private property owner directly. Bidder shall fill all holes and clean up and restore the site(s) to original condition following completion of such work.
- 4.7 The lands upon which the Work is to be performed, right-of-ways for access thereto and other lands designated for use by Contractor in performing the Work are identified in the

Supplementary Conditions, General Requirements, and/or on the Drawings or otherwise in the Contract Documents.

- 4.8 Prior to the submission of a Bid, Bidders shall promptly give written notice to the Owner of any conflict, error, ambiguity, and/or discrepancy in the Contract Documents and Bidders bear full responsibility for determining that Owner's written resolution by formal written Addenda is acceptable to the Bidder.
- 4.9 The submission of a Bid will constitute an incontrovertible representation that the Bidder has complied with every requirement of this Article and these Contract Documents; that no additional examinations, investigations, explorations, studies, or tests are needed; that the Contract Documents are sufficient in scope and detail to indicate and convey understanding of all terms and conditions for performance of the Work; and that the Bidder provided written notice of any conflict, error, ambiguity, and/or discrepancy in the Contract Documents and that Owner's written resolution by formal written Addenda is acceptable to the Bidder.
- 4.10 Representatives of Federal, State and local agencies having a direct interest in the Work shall have access to the Work wherever it is in preparation or progress and the Contractor shall provide proper facilities for such access and inspection.

ARTICLE 5. INTERPRETATIONS AND ADDENDA

- 5.1 All questions about the meaning or intent of the Contract Documents shall be received in writing by the Owner, as described in the City of Providence, Rhode Island Board of Contract and Supply Request for Proposals and the Invitation to Bid of these Specifications, at least ten days before the date set herein for the opening of bids.
- 5.2 Written clarifications or interpretations will be issued by Addenda not later than five days before the bid opening date. Only questions answered by formal written Addenda will be binding. Oral and other clarifications or interpretations will be without legal effect. Addenda will be issued by delivery service with delivery confirmation and/or transmitted electronically to all parties recorded as having received the Contract Documents.
- 5.3 Bidders are responsible for determining that they have received all Addenda issued.

ARTICLE 6. PRE-BID CONFERENCE

- 6.1 If a pre-bid conference is to be held for this project where representatives of the Owner will review and discuss the project, the date, time, and place of the pre-bid conference is specified in the City of Providence, Rhode Island Board of Contract and Supply Request for Proposals and/or Invitation to Bid of these Specifications and the proceeds of any pre-bid conference will be issued by formal written Addenda.

ARTICLE 7. BID SECURITY

- 7.1 Each Bid must be accompanied by Bid Security payable to Owner as indicated in the City of Providence, Rhode Island Board of Contract and Supply Request for Proposals and/or Invitation To Bid of these Specifications. Bid Security shall be sealed in a separate envelope from the Bid and then attached to the envelope containing the Bid. All Bid

Securities will be returned on the execution of the Agreement or if no award is made, no later than 90 days after the actual date of opening of the Bids, unless forfeited under the conditions herein stipulated.

- 7.2 In case a party to whom a Contract is awarded shall fail or neglect to execute the Agreement and furnish the satisfactory bonds, insurance and documents within the time specified, Owner may determine that the Bidder has abandoned the Contract, and thereupon the Bid Forms and acceptance shall be null and void and the Bid Security accompanying the Bid Form shall be forfeited to Owner as liquidated damages for such failure or neglect and to indemnify said Owner for any loss which may be sustained by failure of the Bidder to execute the Contract Agreement and furnish the bonds as aforesaid, provided that the amount forfeited to Owner shall not exceed the difference between the Bid Price of said Bidder and that of the next lowest responsible and eligible bidder and provided further that, in case of death, disability, or other unforeseen circumstances affecting the Bidder, such Bid Security may be returned to the Bidder. After execution of the Agreement and acceptance of the bonds by Owner, the Bid Security accompanying the Bid Form of the Successful Bidder will be returned.

ARTICLE 8. PERFORMANCE, PAYMENT AND OTHER BONDS

- 8.1 Performance, Payment and other Bonds shall be provided in accordance with Article 6 of the General Conditions of the Contract.
- 8.2 All Bonds required as Contract Security shall be furnished with/for the executed Contract Agreement.

ARTICLE 9. TAX EXEMPTION

- 9.1 Owner is exempt from sales tax on materials and equipment permanently incorporated into the Work. A sales tax exemption certificate will be made available by Owner upon request. The cost of such taxes shall not be included with any Bid.

ARTICLE 10. CONTRACT TIME

- 10.1 The Contract duration and the time that the Work and Project must be completed is set forth in the Invitation to Bid, Bid Form, and/or Contract Agreement.

ARTICLE 11. LIQUIDATED DAMAGES

- 11.1 Any work taking place after the contract completion date will be subject to liquidated damages at a rate of \$2,000 for each day that work is being performed.
- 11.2 Additional provisions for liquidated damages, if any, are set forth in the Invitation to Bid, Bid Form, and/or Agreement.

ARTICLE 12. SUBCONTRACTORS, SUPPLIERS, APPRENTICE UTILIZATION & LOCAL HIRING

- 12.1 If the Bid Form requires the listing of proposed subcontractors and/or suppliers, the Bidder shall provide the names and requested information for all subcontractors and/or

suppliers whose prices the Bidder used in preparing the Bid and/or who Bidder knows to intend to enter into agreements with to participate in any portion of the Work. Failure to provide such requested information may, at the Owner's sole discretion, result in the Bid being considered non-responsive and rejected.

- 12.2 If the Contract Documents require the identity of subcontractors, suppliers, individuals, or entities to be submitted to Owner prior to the executed date of the Contract Agreement or prior to their participation in the Work, the Successful Bidder, and any other Bidder so requested, shall within five (5) days after the Bid opening or at other such time requested by the Owner or stated in the Contract Documents submit to Owner a list of all such subcontractors, suppliers, individuals, or entities proposed for stated portions of the Work. Such list shall be accompanied by an experience statement with pertinent information regarding similar projects and other evidence of qualification for each such subcontractor, supplier, individual, or entity if requested by Owner. If the Owner, after due investigation, has reasonable objection to any proposed subcontractor, supplier, individual, or entity, Owner may request Successful Bidder to submit a substitute in which case Successful Bidder shall submit an acceptable substitute.
- 12.3 Bidder shall not be required to employ any subcontractor, supplier, individual, or entity against whom Bidder has reasonable objection.
- 12.4 This Contract is subject to the requirements of the following sections of the Providence Code of Ordinances: Section 21-28.1 – "Qualifications for parties doing business with the City"; Section 2-169.1 – "Local Hiring (First Source)." Refer to "Apprentice Utilization, Local Hiring Requirements, & Air Quality Protocols" included with these Specifications.

ARTICLE 13. MANUFACTURER'S EXPERIENCE, SUBSTITUTES & "EQUAL" ITEMS

- 13.1 Wherever it may be written that an equipment or product manufacturer must have a specified period of experience with its product, equipment and/or products which do not meet the specified experience period can be considered if the supplier or manufacturer is willing to provide a bond or cash deposit for the duration of the specified time period which will guarantee replacement of that equipment in the event of failure. Such bond shall be an Efficiency Guarantee Bond, executed on forms to be approved by the Owner.
- 13.2 The Contract, if awarded, will be on the basis of materials and equipment specified or described in the Contract Documents, including any Addenda issued prior to the receipt of Bids. The materials and equipment described in the Contract Documents establish a standard of required type, function, quality, and performance to be met by any proposed substitute or "equal" item. Whenever it is specified or described in the Contract Documents that a substitute or "equal" item of material or equipment may be furnished or used by the Contractor if acceptable to the Owner, application for such acceptance will not be formally considered by the Owner until after the execution date of the Agreement. The procedure for submission of any such application by the Contractor and consideration by the Owner is set forth in the Contract Documents. The burden of proof of the merit of a proposed substitute or "equal" item is solely upon the Bidder/Contractor, and the Owner's decision of approval or disapproval will be final. The Bidder shall not rely on any assumption of approval by the Owner in preparing their Bid.

- 13.3 Any request for substitute or “or equal” shall include the Manufacturer’s Certification of compliance with the Build America, Buy America Act (BABAA) requirements mandated by Title IX of the Infrastructure Investment and Jobs Act (“IIJA”), Pub. L. 177-58.

ARTICLE 14. LAWS, REGULATIONS, ORDINANCES, REQUIREMENTS, PERMITTING & WAGE RATES

- 14.1 The language of all applicable Federal, State, and local laws, regulations, and ordinances shall be deemed to be incorporated into this Contract herein by reference. Bidders shall be familiar with and comply with all applicable laws, regulations, ordinances, and requirements that may in any way affect the cost, progress, and/or performance of the Work and the price submitted with their Bids. Bidders assume full responsibility for full compliance with all applicable Federal, State, and local laws, regulations, ordinances, and requirements.
- 14.2 Applicable provisions of the State of Rhode Island General Laws and/or the United States Code and Code of Federal Regulations govern this Contract and any provision in violation of the foregoing shall be deemed null, void, and of no effect. Where conflict between the Code of Federal Regulations and State Laws exist, the more stringent shall apply.
- 14.3 The work of this Contract shall specifically comply with RIGL Chapter 37, RICR 220-RICR-80-10-2, EPA 2 CFR Part 200 and 40 CFR Part 33.
- 14.4 Bidder must comply with all Federal, State, and local permitting requirements applicable to the Work.
- 14.5 By the submission of a Bid, the Bidder represents to the Owner that the Bidder is in full compliance with and will comply with all such requirements specified herein.

ARTICLE 15. BID FORM

- 15.1 Each Bid shall be submitted on the Bid Form included in the Contract Documents. Additional copies of the Bid Form may be appended to the Project Manual. The Bid Form shall be removed and submitted separately. All blank spaces for Bid prices must be filled in with the unit price for the item or the lump sum for which the Bid is made.
- 15.2 Bid Forms shall be completed in ink or by typewriter. The Bid price of each item on the form shall be stated in words and figures. If unit prices are required on the Bid Form, discrepancies between unit prices and their respective total amounts will be resolved in favor of the unit prices. Discrepancies between words and figures will be resolved in favor of words. Discrepancies between the indicated sum of any column of figures and the correct sum thereof will be resolved in favor of the correct sum.
- 15.3 Bids by corporations shall be executed in the corporate name by the president or a vice-president (or other corporate officer accompanied by evidence of authority to sign) and the corporate seal shall be affixed and attested by the secretary or an assistant secretary. The corporate address and state of incorporation shall be shown below the signature.

- 15.4 Bids by Limited Liability Companies shall be executed in the Limited Liability name by the Manager (or other Limited Liability Company officer/representative accompanied by evidence of authority to sign). The Limited Liability Company address and state where the Limited Liability Company was formed shall be shown below the signature.
- 15.5 Bids by partnerships shall be executed in the partnership name and signed by a partner, whose title shall appear under the signature. The official address of the partnership shall be shown below the signature.
- 15.6 Bid Forms shall be signed and executed in ink.
- 15.7 All names shall be typed or printed below the signature.
- 15.8 The Bid shall contain an acknowledgement of receipt of all Addenda (the numbers of which shall be filled in on the Bid Form).
- 15.9 The address and phone number to which communications regarding the Bid are to be directed shall be shown.
- 15.10 The Bid shall include evidence of Bidder's authority and qualifications to do business in the State of Rhode Island. Bidder's State of Rhode Island contractor license number(s) shall be shown on the Bid Form or otherwise provided with the Bid.
- 15.11 The Bid and Bid Forms shall be submitted with all required forms and information, including but not limited to all City of Providence forms and information, Bidder's Qualifications Forms, MBE/WBE/DBE Forms and Proposed Subcontractors & Suppliers. Failure to submit required forms and information will result in rejection of a Bid.

ARTICLE 16. RECEIPT OF BIDS

- 16.1 Copies of Bids shall be submitted in accordance with the City of Providence, Rhode Island Board of Contract and Supply Request For Proposals, Invitation To Bid, and these Instructions to Bidders of these Specifications. Bids shall be submitted in a sealed opaque envelope bearing on the outside the Bidder's name, address, and the Project Title for which the Bid is submitted. The Bid shall be addressed to and submitted as specified in the City of Providence, Rhode Island Board of Contract and Supply Request For Proposals and Invitation To Bid of these Specifications (If forwarded by mail, Bid and sealed envelope marked as described above shall be enclosed in another envelope with the notation "BID ENCLOSED" on the face and addressed as specified).
- 16.2 Sealed Bids for the Work of this Contract will be received at the time and place indicated in the City of Providence, Rhode Island Board of Contract and Supply Request For Proposals and Invitation To Bid of these Specifications
- 16.3 Owner may consider informal any Bid not prepared and submitted in accordance with the provisions hereof.
- 16.4 It is the responsibility of each individual Bidder to assure that their Bid is in the possession of the responsible official or the designated alternate prior to the stated time

and at the place of the Bid Opening. Owner is not responsible for Bids delayed by mail and/or delivery services, of any nature.

- 16.5 All Bids will remain subject to acceptance for the period of time stated in the Contract Documents. Owner may, at its sole discretion, release any Bid and return any Bid security prior to the end of this period.

ARTICLE 17. MODIFICATION AND WITHDRAWAL OF BIDS

- 17.1 Bids may be modified only by an appropriate document duly executed (in the manner that a Bid must be executed) and delivered to the place where Bids are to be submitted at any time prior to the opening of Bids.
- 17.2 Bids may be withdrawn prior to the scheduled time (or authorized postponement thereof) for the opening of Bids.
- 17.3 Any Bid received after the time and date specified shall not be considered. No Bid may be withdrawn for a period of 60 days, after the actual date of the opening of the Bids.

ARTICLE 18. EVALUATION OF BIDS & BASIS OF AWARD

- 18.1 In evaluating Bids, Owner will consider whether or not Bids comply with the prescribed requirements herein, pricing, and other data, as may be requested in the Bid Form, Advertisement, Request For Proposals, Invitation To Bid, and/or Instructions To Bidders.
- 18.2 Bid evaluation will be based on total of Base Bid plus all Supplemental Bid Items. Award will be based on Base Bid plus Owner-selected Supplementary Bid Items.
- 18.3 In evaluating Bids, Owner will consider the qualifications and experience of Bidders and may also consider the qualifications and experience of subcontractors, suppliers, and other individuals or entities proposed by Bidders for portions of the Work as submitted with the Bid Form.
- 18.4 Owner may conduct such investigations as Owner deems necessary to establish the responsibility, qualifications, experience, capability, and financial ability of Bidders, proposed subcontractors, suppliers, individuals, and/or entities proposed to perform the Work.
- 18.5 Discrepancies on the Bid Form will be resolved as previously specified herein.
- 18.6 Evaluation of Bids and Bidders:
- A. Bids and Bidders will be evaluated based on the following criteria:
1. The qualifications and experience of Bidders as set forth and specified herein and in the Contract Documents.
 2. The Bid Prices (resolved in favor of unit price amounts) submitted on the Bid Form.
 3. The adequacy of the financial resources of Bidders.

4. The ability of Bidder to comply with Article 6 of the Standard General Conditions of the Construction Contract, as amended and/or modified by the Supplementary Conditions.
5. The adequacy and availability of equipment of Bidders.
6. The experience of Bidders and quality of work performed previously on projects for Owner, if any, and on projects of comparable size for other entities.
7. The record of Bidders in accomplishing and completing work on other, similar projects within the required and contractual timeframes.
8. The ability of Bidders to obtain the necessary and required/specified materials for the Work.
9. Consistency with historical pricing of similar and related work.
10. Completeness of the required forms submitted with each bid and confirmation that the Bidder meets the minimum requirements.

ARTICLE 19. AWARD OF CONTRACT

- 19.1 The intent of the Owner is to award one contract to the lowest qualified and responsible Bidder (Successful Bidder). Such a Bidder shall possess the skill, ability, and integrity necessary for the faithful performance of the Work and shall meet the required minimum qualifications specified herein.
- 19.2 Owner reserves the right to reject any and all Bids, to waive any and all informalities if it is in Owner's best interest to do so, and the right to disregard all nonconforming, non-responsive, unbalanced or conditional Bids.
- 19.3 Owner reserves the right to reject the Bid of any Bidder whom it finds, after reasonable inquiry and evaluation, to be not responsible and/or not meet the required qualifications specified herein and that Owner considers to be unqualified to perform the Work of the Project.
- 19.4 Owner reserves the right to reject the Bid of any Bidder if in Owner's sole opinion would not be in the best interest of the Owner or project to make an award to Bidder.
- 19.5 A Bid which includes for any item a Bid Price that is abnormally low or high may be rejected as unbalanced.
- 19.6 More than one Bid for the same Work or Project from an individual or entity under the same or different names will not be considered. Reasonable grounds for believing that any Bidder has an interest in more than one Bid for the Work may be cause for the disqualification of that Bidder and the rejection of all Bids for which that Bidder has an interest.
- 19.7 In evaluating Bids, Owner will consider whether or not the Bids comply with the specified requirements of the City of Providence, Rhode Island Board of Contract and Supply

Request For Proposals, Invitation To Bid and Instructions To Bidders of these Specifications.

- 19.8 In evaluating Bids, Owner will consider the qualifications and experience of Bidders as specified herein, and may also consider the qualifications and experience of any subcontractors, suppliers, and other individuals or entities proposed for portions of the Work as submitted by Bidder with the Bid.
- 19.9 If the Contract is to be awarded, Owner will award the Contract to the Successful Bidder whose bid represents the best interests of the Owner and project and will provide a Notice of Award to the Successful Bidder.
- 19.10 Owner may, at Owner's sole discretion, release any Bid and return the Bid Security at any time.

ARTICLE 20. EXECUTION OF AGREEMENT

- 20.1 When Owner gives a Notice of Award to the Successful Bidder, the Successful Bidder shall deliver the required Bonds, Insurance Certificates and all other applicable Contract Documents to the Owner within the time period specified in the Standard General Conditions of the Construction Contract, as may be amended and/or modified by the Supplementary Conditions. Owner will prepare the Contract Agreement and provide unsigned copies of the Agreement to the Successful Bidder for execution. The Successful Bidder shall execute the Agreement and return it to Owner and Owner shall then execute the Agreement and return copy(ies) of the fully executed Agreement to the Successful Bidder as specified in the Standard General Conditions of the Construction Contract, as may be amended and/or modified by the Supplementary Conditions.
- 20.2 The Contract Agreement provided in these Specifications is a sample of the Contract Agreement to be executed by the Successful Bidder. Owner reserves the right to negotiate contract terms and conditions with the Successful Bidder.

ARTICLE 21. GUARANTEE & WARRANTY

- 21.1 The Contractor guarantees that the Work and Services to be performed under the Contract, and all workmanship, materials, and equipment performed, furnished, used or installed in the construction of the same shall be free from defects and flaws, and shall be performed and furnished in strict accordance with the Drawings, Specifications, and other Contract Documents, that the strength of all parts of all manufactured equipment shall be adequate and as specified, and that the performance test requirements of the Contract Documents shall be fulfilled. Unless otherwise specified in other sections of the Contract Documents or in required permits, this guarantee shall be for a period of one year minimum from and after the date of completion and acceptance of the Work as stated in the final estimate. If part of the Work is accepted in accordance with that subsection of this Agreement titled "Partial Acceptance," the guarantee for that part of the Work shall be for a period of one-year minimum from the date fixed for such acceptance.
- 21.2 If at any time within the said period of guarantee any part of the Work requires repairing, correction or replacement, the Owner may notify the Contractor in writing to make the required repairs, corrections or replacements. If the Contractor neglects to commence



making such repairs, corrections or replacements to the satisfaction of the Owner within seven days from the date of receipt of such notice, or having commenced fails to prosecute such Work with diligence, the Owner may employ other persons to make said repairs, corrections or replacements, and charge the costs, including compensation for additional professional services, to the Contractor.

ARTICLE 22. PAYMENT AND RETAINAGE

22.1 Provisions regarding payments to Contractor and retainage withheld are set forth in the General and Supplementary Conditions and the Contract Agreement. At the Owner's sole discretion, retainage held from prior Applications for Payment may be released at any time.

ARTICLE 23. FEDERAL AND STATE REQUIREMENTS

23.1 This project is subject to the Davis-Bacon Prevailing Wage Requirements, Federal Wage Rates, American Iron and Steel Requirements, Build America Buy America (BABA) Requirements, EPA DBE Requirements, EPA Debarment and Suspension Requirements, EPA Prohibition on certain Telecommunication and Video Surveillance Requirements, and Rhode Island MBE Utilization Requirements.

PROVIDENCE WATER SUPPLY BOARD
CITY OF PROVIDENCE, RHODE ISLAND

END OF SECTION

SECTION 00 30 00 AVAILABLE INFORMATION

PART 1 GENERAL

1.01 GENERAL INFORMATION

- A. Information made available is for Bidder's review and convenience. Refer to the City of Providence, Rhode Island Board of Contract and Supply Request For Proposals, Invitation to Bid, Instructions to Bidders, and the General and Supplemental Contract Conditions of these Specifications for further information pertaining to the use of these documents and information, as well as what documents and information constitute part of the Contract Documents.
- B. Owner makes no warranty, expressed or implied, regarding the accuracy, completeness, or usefulness of information made available to Bidders. Bidders, Contractors, and any other user of provided information assumes all liability and responsibility for the fitness for a particular use.
- C. Unless otherwise provided in these Contract Documents, information made available to Bidder is available for review by appointment at Owner's (Providence Water) Central Operations Facility (COF), 125 Dupont Drive, Providence, Rhode Island 02907. See the City of Providence, Rhode Island Board of Contract and Supply Request For Proposals and Instructions to Bidders of these Specifications for contact information to set up an appointment.

1.02 OWNER (PROVIDENCE WATER) INFORMATION

- A. Information that Owner makes available to Bidders and Contractors includes but is not limited to:
 - 1. Technical specifications, requirements and typical standard construction details (see the Appendices of these Specifications, which are part of these Contract Documents). These documents are the Owner's typical construction specifications and details for water main and water service line construction, which must be adhered to for all Work of this Project.
 - 2. List of Approved Materials & Manufacturers for use in the Providence Water Distribution System (see the Appendices of these Specifications, which are part of these Contract Documents). This guidance document provides a quick reference of approved materials and manufacturers that meet the intent of the items and materials specified herein and in the specifications (included in the Appendices of these Specifications). It is the responsibility of all Bidders and Contractors prior to construction to verify that the items and materials to be provided are acceptable to the Owner.
 - 3. Distribution Sheets. Owner will make available distribution sheets for Contractor to schedule and sequence the Work (if needed), as well as to plan and layout temporary bypass piping (if required).

4. Requirements for Water Mains, Services and Appurtenances. This document provides general information related to Owner administrative procedures, engineering requirements, materials, construction procedures, and typical construction installation details and can be accessed at <https://provwater.com/sites/default/files/forms/ReqWaterMainsServAppurt.pdf>.
5. Locations for replacement of lead water service lines throughout Owner's retail water service area. A list of proposed replacements is included in Appendix A of these contract documents.

1.03 RHODE ISLAND ENERGY (FORMERLY NATIONAL GRID) INFORMATION

- A. Information from Rhode Island Energy that is available to Bidders and Contractors includes but is not limited to:
 1. Rhode Island Energy Guidelines (see the Appendices of these Specifications). These guidelines show sketches and related criteria related to cast-iron (CI) gas main encroachments for informational purposes only. Contractor shall notify Rhode Island Energy of any locations where CI gas mains are exposed to the limits indicated in the guidelines, where CI gas mains are parallel to excavations for this Work, and where CI gas main bell and spigot joints are exposed. This information is provided for Contractor convenience only, as furnished by Rhode Island Energy to Owner. It is the sole responsibility of the Contractor to contact and coordinate with Rhode Island Energy as required throughout all the Work of the entire Project.

1.04 CITY OF PROVIDENCE INFORMATION

- A. Information from the City of Providence that is available to Bidders and Contractors through the City of Providence includes but is not limited to:
 1. *City of Providence Standards to be Employed by Public Utility Operators When Restoring any of the Streets, Lanes, and Highways in Providence ("the Standards")*, dated June 2008.

PART 2 PRODUCTS (NOT USED)

PART 3 EXECUTION (NOT USED)

END OF SECTION



**BID FORM
TO
PROVIDENCE WATER
ACCELERATED LEAD SERVICE LINE REPLACEMENT PROGRAM – CONTRACT 1.4
PROJECT NO. 20234**

This Bid is submitted to the City of Providence, Board of Contract and Supply, Department of the City Clerk, Room 311, Providence City Hall, 25 Dorrance Street, Providence, Rhode Island 02903.

The undersigned declares that the only persons or parties interested in this Bid as principals are as stated; that the Bid is made without any collusion with other persons, firms, or corporations; that all the Contract Documents dated March 2024 have been carefully examined; that the undersigned is fully informed in regard to all conditions pertaining to the Work and the places where it is to be done, and from them the undersigned makes this Bid. These prices shall cover all expenses incurred in performing the Work required under the Contract Documents, of which this Bid Form is a part.

If a Notice of Award accompanied by unsigned copies of the Agreement and all other applicable Contract Documents is delivered to the undersigned after the actual date of the opening of the Bids, the undersigned, in accordance with the Standard General Conditions of the Construction Contract as amended and/or modified by the Supplementary Conditions, will execute and return all copies of the Agreement and all other applicable Contract Documents to Owner. The premiums for all Bonds and Insurance required shall be paid by Contractor and shall be included in the Contract Prices. The undersigned Bidder further agrees that the Bid Security accompanying this Bid shall become the property of Owner if the Bidder fails to execute the Agreement as stated above.

The undersigned hereby agrees to fully complete the Work within the times specified in the Contract Documents and in the Agreement.

The undersigned acknowledges receipt of addenda numbered:

In accordance with the above understanding, the undersigned proposes to perform the Work, furnish all materials and complete the Work in its entirety in the manner and under the conditions required at the prices listed as follows:

**PROVIDENCE WATER
ACCELERATED LEAD SERVICE LINE REPLACEMENT PROGRAM - CONTRACT 1.4
PROJECT NO. 20234**

BID FORM

<u>ITEM NO.</u>	<u>ESTIMATED QUANTITY</u>	<u>BRIEF DESCRIPTION OF ITEMS WITH UNIT BID PRICE IN WORDS</u>	<u>UNIT BID PRICE IN FIGURES</u>	<u>AMOUNT IN FIGURES</u>
1A	19 each	Lead Service Line Replacement - Public Side Only (Water Main to Curb Stop) <hr/> each	\$ <hr/>	\$ <hr/>
1B	487 each	Lead Service Line Replacement - Public Side Portion of a Full Replacement (Water Main to Curb Stop) <hr/> each	\$ <hr/>	\$ <hr/>
1C	120 each	Test Pit at Curb Stop <hr/> each	\$ <hr/>	\$ <hr/>
1D	60 each	New Curb Box - (For Replacements Under Item 2A) <hr/> each	\$ <hr/>	\$ <hr/>
1E	280 each	Long Side Replacement <hr/> each	\$ <hr/>	\$ <hr/>
1F	1,100 CY	Lead Service Line Excavation Greater Than Five (5) Feet <hr/> per cubic yard	\$ <hr/>	\$ <hr/>
1G	300 SY	Final Trench Pavement Restoration (Infra-red) <hr/> per square yard	\$ <hr/>	\$ <hr/>
1H	600 SY	Final Trench Pavement Restoration (Milling and Paving) <hr/> per square yard	\$ <hr/>	\$ <hr/>

**PROVIDENCE WATER
ACCELERATED LEAD SERVICE LINE REPLACEMENT PROGRAM - CONTRACT 1.4
PROJECT NO. 20234**

BID FORM

<u>ITEM NO.</u>	<u>ESTIMATED QUANTITY</u>	<u>BRIEF DESCRIPTION OF ITEMS WITH UNIT BID PRICE IN WORDS</u>	<u>UNIT BID PRICE IN FIGURES</u>	<u>AMOUNT IN FIGURES</u>
1I	63,000 SY	Final Pavement (Curb-to-curb) _____ per square yard	\$ _____	\$ _____
1J	\$ 245,000.00 ALLOWANCE	Uniformed Police Traffic Control _____ Two hundred and forty five thousand and zero cents allowance	\$ 245,000.00	\$ 245,000.00
1K	\$ 150,000.00 ALLOWANCE	Flaggers for Traffic Control _____ One hundred and fifty thousand dollars and zero cents allowance	\$ 150,000.00	\$ 150,000.00
1L	\$ 50,000.00 ALLOWANCE	Utility Provisions _____ Fifty thousand dollars and zero cents allowance	\$ 50,000.00	\$ 50,000.00
2A	572 each	Lead Service Line Replacement - Private Side Only (Curb Stop to Meter) - _____ each	\$ _____	\$ _____
2B	460 each	Lead Service Line Replacement - Private Side Portion of a Full Replacement (Curb Stop to Meter) - _____ each	\$ _____	\$ _____
2C	120 each	Access Not Provided _____ each	\$ _____	\$ _____
2D	140 each	Reduced Pressure Zone (RPZ) Backflow Preventer _____ each	\$ _____	\$ _____

**PROVIDENCE WATER
ACCELERATED LEAD SERVICE LINE REPLACEMENT PROGRAM - CONTRACT 1.4
PROJECT NO. 20234**

BID FORM

<u>ITEM NO.</u>	<u>ESTIMATED QUANTITY</u>	<u>BRIEF DESCRIPTION OF ITEMS WITH UNIT BID PRICE IN WORDS</u>	<u>UNIT BID PRICE IN FIGURES</u>	<u>AMOUNT IN FIGURES</u>
3A	21 each	Lead Service Line Replacement - Commercial - Private Side Only (Curb Stop to Meter) <hr/> each	\$ <hr/>	\$ <hr/>
3B	30 each	Lead Service Line Replacement - Commercial - Private Side Portion of a Full Replacement (Curb Stop to Meter) <hr/> each	\$ <hr/>	\$ <hr/>
4	3,800 each	Pitcher Filters and Replacement Cartridges <hr/> each	\$ <hr/>	\$ <hr/>
TOTAL BASE BID PRICE IN WORDS (Items 1A-4)			<hr/>	<hr/>
TOTAL BASE BID PRICE IN FIGURES (Items 1A-4)			<hr/>	<hr/>

*Transfer Total Base Bid in words and figures to Section 001000 Bid Form 1 Bidders Blank (Page 7 of 30) under "Total Amount in Writing and Total Amount in Figures.

**PROVIDENCE WATER
ACCELERATED LEAD SERVICE LINE REPLACEMENT PROGRAM - CONTRACT 1.4
PROJECT NO. 20234**

BID FORM

<u>ITEM NO.</u>	<u>ESTIMATED QUANTITY</u>	<u>BRIEF DESCRIPTION OF ITEMS WITH UNIT BID PRICE IN WORDS</u>	<u>UNIT BID PRICE IN FIGURES</u>	<u>AMOUNT IN FIGURES</u>
S-1A	850 CY	Imported Common Fill _____ per cubic yard	\$ _____	\$ _____
S-1B	120 CY	Crushed Stone _____ per cubic yard	\$ _____	\$ _____
S-1C	20 CY	Flowable Fill _____ per cubic yard	\$ _____	\$ _____
S-2	105 CY	Miscellaneous Concrete _____ per cubic yard	\$ _____	\$ _____
S-3	\$ 600,000.00 ALLOWANCE	Miscellaneous Work at Direction of the Owner Six hundred thousand dollars and zero cents allowance _____	\$ 600,000.00	\$ 600,000.00
TOTAL SUPPLEMENTAL PRICE IN WORDS (S-1A through S-3)			_____	
TOTAL SUPPLEMENTAL PRICE IN FIGURES (S-1A through S-3)			_____	

**PROVIDENCE WATER
ACCELERATED LEAD SERVICE LINE REPLACEMENT PROGRAM - CONTRACT 1.4
PROJECT NO. 20234**

BID FORM

<u>ITEM NO.</u>	<u>ESTIMATED QUANTITY</u>	<u>BRIEF DESCRIPTION OF ITEMS WITH UNIT BID PRICE IN WORDS</u>	<u>UNIT BID PRICE IN FIGURES</u>	<u>AMOUNT IN FIGURES</u>
TOTAL BASE BID PRICE PLUS SUPPLEMENTAL PRICE IN WORDS			<hr/>	
TOTAL BASE BID PRICE PLUS SUPPLEMENTAL PRICE IN FIGURES			<hr/>	

The undersigned agrees that extra work, if any, will be performed in accordance with Article 11 of the Conditions of the Contract and will be paid for in accordance with Article 12 of the Conditions of the Contract.

The undersigned agrees to furnish Performance and Payment Bonds as specified with a surety company acceptable to the Owner.

Amounts shall be shown in both words and figures, where indicated. In case of discrepancy, the amount shown in words will govern.

The above prices shall include all labor, materials, bailing, shoring, removal, overhead, profit, insurance and incidentals required to complete the Work.

The undersigned acknowledges that (1) they have examined the Contract Documents thoroughly, including all the requirements specified in the Request For Proposals, Invitation to Bid and Instructions to Bidders; (2) they have had the opportunity to visit the site(s) to become familiar with local conditions that may in any manner affect cost, progress or performance of the Work; (3) they are familiar with all Federal, State and local laws, ordinances, rules and regulations that may in any manner affect cost, progress or performance of the Work; and (4) they have studied and carefully correlated Bidder's observations with the requirements of the Contract Documents.

The undersigned acknowledges that they have had the opportunity to make additional investigations and tests as they may deem necessary to determine their Bid for performance of the Work in accordance with the time, price and other terms and conditions of the Contract Documents.

The undersigned acknowledges they are familiar with all laws and regulations that may affect cost, progress, and performance of the work, including BABAA requirements.

The undersigned agrees that the submission of this Bid is an incontrovertible representation that the Bidder has complied with every requirement of this Article and these Contract Documents; that no additional examinations, investigations, explorations, studies, or tests are needed; that the Contract Documents are sufficient in scope and detail to indicate and convey understanding of all terms and conditions for performance of the Work; and that the Bidder provided written notice of any conflict, error, ambiguity, and/or discrepancy in the Contract Documents and that Owner's written resolution by formal written Addenda is acceptable to the Bidder.

The undersigned acknowledges that they have submitted the following with this Bid and with their Bid Forms of this Section and further that it is their sole responsibility to confirm that they have submitted all required forms and/or information with their Bid whether or not it is listed herein (failure to submit all required information may result in rejection of a Bid):

1. Bid Form 1: Bidder's Blank as the cover/first page.
2. Bid Form 2: Certification of Bidder as the second page.
3. Bid Form 3: Certificate Regarding Public Records as the third page.
4. Bid Form 4: Affidavit of City Vendor as the fourth and fifth page.
5. Bid Form 5: Bidder Certification, Performance of the Work as the sixth page.
6. Forms from the Minority and Women Business Enterprise Program.
7. Completed Bid Forms from this Section with Bid prices for each item stated in words and figures; acknowledgement of receipt of all Addenda; signed and executed City of Providence, Rhode Island Board of Contract and Supply signature page; and with included evidence of Bidder's authority to do business in the State of Rhode Island and Bidder's Rhode Island contractor license number(s).
8. Bid Security in a separate envelope from the Bid and then attached to the envelope containing the Bid.
9. Completed forms from Section 00 43 36 – Proposed Subcontractors & Suppliers, with supporting documentation as required.
10. Completed forms from Section 00 45 13 – Bidder's Qualifications, with supporting documentation as required.

Bids will remain subject to acceptance for 60 days after the Bid opening, or for such longer time period that Bidder may agree to in writing upon request of the Owner.

The names and residences of all persons and parties interested in the foregoing Bid as principals are as follows:

(Give first and last names in full. See Bid Form Article in the Instructions to Bidders.)

The undersigned hereby certifies that they are able to furnish labor that can work in harmony with all other elements of labor employed or to be employed on the Work.

The undersigned hereby certifies under the penalties of perjury that this Bid is in all respects bona fide, fair and made without collusion or fraud with any other person. As used in this section, the word "person" shall mean any natural person, joint venture, partnership, corporation, or other business or legal entity.



BOARD OF CONTRACT AND SUPPLY
CITY OF PROVIDENCE, RHODE ISLAND

BID FROM:

Company Name: _____

(SEAL)

If incorporated, State of Incorporation: _____

Date of Incorporation: _____

Type of Business (from incorporation papers): _____

By: _____

(Signature - attach evidence of authority to sign if not an individual submitting Bid)

Name (typed or printed): _____

Title: _____

Date: _____

Business Address: _____

Phone No. _____ Fax No. _____

Bidder State of Rhode Island License Information:

License No.

Type of License/Trade Licensed



SECTION 00 43 36
PROPOSED SUBCONTRACTORS & SUPPLIERS

PART 1 GENERAL

1.01 GENERAL REQUIREMENTS

- A. Bidder must, to the best of their knowledge at the time of the Bid, completely provide all information requested herein and submit the form(s) of this Section attached to their Bid Forms. Failure to submit this information may result in rejection of a Bid.
- B. Bidder shall provide and submit to Owner any additional information requested by Owner to demonstrate that proposed Subcontractors and Suppliers are sufficiently capable and qualified of performing their required work or supplying equipment and/or materials.
- C. Bidder must clearly identify the scope of work to be performed by all proposed Subcontractors and the items, materials, and/or equipment to be provided by a proposed Supplier.
- D. If sufficient space is not available on the provided form, Bidder may use and attach additional sheets (including copying the attached form) as needed to fully satisfy the requirements of this section.

PART 2 PRODUCTS (NOT USED)

PART 3 EXECUTION (NOT USED)

END OF SECTION



PROPOSED SUBCONTRACTORS & SUPPLIERS FORM

<u>SUBCONTRACTOR NAME</u>	<u>LICENSE NO.</u>	<u>SCOPE OF WORK</u>
_____	_____	_____
_____	_____	_____
_____	_____	_____
_____	_____	_____
_____	_____	_____
_____	_____	_____
_____	_____	_____

<u>SUPPLIER NAME</u>	<u>MATERIALS AND/OR EQUIPMENT TO BE PROVIDED</u>
_____	_____
_____	_____
_____	_____
_____	_____
_____	_____
_____	_____
_____	_____

CERTIFICATION:

The undersigned certifies that all information provided herein is complete, true, and accurate.

COMPANY NAME: _____

SIGNATURE: _____

NAME (typed or printed): _____

TITLE: _____

DATE: _____

SECTION 00 45 13
BIDDER'S QUALIFICATIONS

PART 1 GENERAL

1.01 GENERAL REQUIREMENTS

- A. Bidder must, to the best of their knowledge at the time of the Bid, completely provide all information requested herein and submit the forms of this Section attached to their Bid Forms. Failure to submit this information may result in rejection of a Bid.
- B. Bidders must provide actual number of lead service line replacements where requested.
- C. Bidder agrees to furnish to Owner an audited or certified financial statement of as recent a date as possible, including the latest balance sheet and income statement, as well as any other supporting financial documentation requested by Owner.
- D. Bidder shall list projects that meet the requirements in Section 00 21 13, Article 2.2.
- E. Bidder shall provide and submit to Owner any additional information requested by Owner to demonstrate their ability, experience, qualifications, and financial security to perform the Work.
- F. If sufficient space is not available on the provided forms, Bidder may use and attach additional sheets as needed (including copying the attached forms) to fully satisfy the requirements of this section.

PART 2 PRODUCTS (NOT USED)

PART 3 EXECUTION (NOT USED)

END OF SECTION



BIDDER/CONTRACTOR QUALIFICATIONS FORM

COMPANY INFORMATION:

COMPANY NAME: _____

STREET ADDRESS: _____
(Street Address, City/Town, State, and Zip Code)

MAILING ADDRESS (if different): _____

TELEPHONE NO.: _____ FAX NO.: _____

EMAIL ADDRESS(ES): _____

TYPE OF BUSINESS: _____
(Corporation, Partnership, Sole Proprietorship, Joint Venture, Other (explain))

STATE INCORPORATED OR REGISTERED TO DO BUSINESS: _____

DATE INCORPORATED OR REGISTERED TO DO BUSINESS: _____

NAMES OF COMPANY OFFICERS & TITLES:

Name:

Title:

LICENSE NUMBERS (MUST BE IN RHODE ISLAND):

Business/Trade:

License No.:



BONDING/SURETY INFORMATION:

BONDING/SURETY COMPANY NAME: _____

BONDING/SURETY CONTACT NAME: _____

STREET ADDRESS: _____
(Street Address, City/Town, State, and Zip Code)

MAILING ADDRESS (if different): _____

TELEPHONE NO.: _____ FAX NO.: _____

EMAIL ADDRESS: _____

HOW LONG HAS BIDDER/CONTRACTOR BEEN A CUSTOMER (YEARS)?: _____

WILL BONDING BE READILY PROVIDED FOR THIS WORK (YES/NO)*: _____
(* Please provide and attach a letter from bonding company indicating their intent to provide the required bonds.)

WHAT ARE THE BONDING LIMITS OF THE BIDDER/CONTRACTOR?:

\$ _____
(Aggregate)

\$ _____
(Single)

WHAT IS THE TOTAL AMOUNT OF WORK THAT BIDDER/CONTRACTOR CURRENTLY HAS BONDED?: \$ _____

HAS THERE EVER BEEN ANY ACTION TAKEN AGAINST THE BOND OF THE BIDDER/CONTRACTOR (YES/NO, IF YES EXPLAIN)?: _____

HAS THE BIDDER/CONTRACTOR EVER FAILED TO COMPLETE ANY WORK (YES/NO, IF YES EXPLAIN)?: _____



FINANCIAL INFORMATION:

(Bidder/Contractor shall provide/attach a signed letter authorizing Owner to inquire about financial status & records.)

BANK NAME: _____

BANK CONTACT NAME: _____

STREET ADDRESS: _____
(Street Address, City/Town, State, and Zip Code)

MAILING ADDRESS (if different): _____

TELEPHONE NO.: _____ FAX NO.: _____

EMAIL ADDRESS: _____

HOW LONG HAS BIDDER/CONTRACTOR BEEN A CUSTOMER (YEARS)?: _____

WHAT ARE THE AVERAGE ACCOUNT BALANCES OF THE BIDDER/CONTRACTOR (IF NOT ACTUAL ACCOUNT BALANCES, NUMBER OF FIGURES)?: \$ _____

IF THE BIDDER/CONTRACTOR HAS A LINE OF CREDIT, WHAT IS THE LIMIT AND IS IT SECURED OR UNSECURED?: \$ _____

HAS THE BIDDER/CONTRACTOR HAD OVERDRAFTS OR RETURNED PAYMENTS (YES/NO, IF YES EXPLAIN)?: _____

BANK NAME: _____

BANK CONTACT NAME: _____

STREET ADDRESS: _____
(Street Address, City/Town, State, and Zip Code)

MAILING ADDRESS (if different): _____

TELEPHONE NO.: _____ FAX NO.: _____

EMAIL ADDRESS: _____

HOW LONG HAS BIDDER/CONTRACTOR BEEN A CUSTOMER (YEARS)?: _____

WHAT ARE THE AVERAGE ACCOUNT BALANCES OF THE BIDDER/CONTRACTOR (IF NOT ACTUAL ACCOUNT BALANCES, NUMBER OF FIGURES)?: \$ _____

IF THE BIDDER/CONTRACTOR HAS A LINE OF CREDIT, WHAT IS THE LIMIT AND IS IT SECURED OR UNSECURED?: \$ _____

HAS THE BIDDER/CONTRACTOR HAD OVERDRAFTS OR RETURNED PAYMENTS (YES/NO, IF YES EXPLAIN)?: _____



QUALIFICATIONS INFORMATION:

DESCRIBE/LIST QUALIFICATIONS AS REQUIRED PER THE INSTRUCTIONS TO BIDDERS (SECTION 00 21 13), QUALIFICATIONS ARTICLE 2 (AND PROVIDE SUPPORTING PROJECT REFERENCE INFORMATION ON THE PAGES AT THE END OF THIS SECTION):

DESCRIBE/LIST THE CATEGORIES/TYPES OF WORK THAT BIDDER/CONTRACTOR WILL PERFORM WITH ITS OWN LABOR FORCES AND EQUIPMENT:

WHAT IS THE TOTAL DOLLAR VALUE OF THE LARGEST SINGLE CONTRACT THAT BIDDER/CONTRACTOR HAS COMPLETED: \$

WHAT IS THE TOTAL DOLLAR VALUE OF BIDDER/CONTRACTOR'S CURRENT WORK BACKLOG: \$

HAS THE BIDDER/CONTRACTOR EVER FAILED TO COMPLETE ANY WORK (YES/NO, IF YES EXPLAIN AND ATTACH ADDITIONAL SHEETS AS NEEDED):



DOES THE BIDDER/CONTRACTOR HAVE ANY UNRESOLVED CLAIMS OR LAWSUITS PENDING AS A RESULT OF WORK IT PERFORMED (YES/NO, IF YES EXPLAIN AND ATTACH ADDITIONAL SHEETS AS NEEDED): _____

PROVIDE/ATTACH A LIST OF ALL MAJOR ITEMS OF EQUIPMENT THAT BIDDER/CONTRACTOR HAS AVAILABE FOR USE FOR THE WORK, INCLUDING THE AGE AND EXTENT OF OWNERSHIP IN EACH.

PROVIDE/ATTACH THE EXPERIENCE AND QUALIFICATIONS (E.G., RESUMES) OF BIDDER/CONTRACTOR’S KEY PERSONNEL FOR THIS WORK (CORPORATE OFFICERS OR PARTNERS, SUPERINTENDENT, FOREMEN, LABORERS, ETC.).

PROVIDE/ATTACH A LIST OF ALL CONTRACTS ENTERED INTO DURING THE PAST FIVE (5) YEARS (INCLUDING OTHER CURRENT/ONGOING WORK), INDICATING THE TYPE OF WORK AND VALUE OF THE CONTRACT.

ON THE FOLLOWING PAGES, PROVIDE PROJECT REFERENCE INFORMATION. PROJECT REFERENCES SHOULD INCLUDE WORK WITHIN THE PAST TEN (10) YEARS OF A SIMILAR NATURE TO THIS CONTRACT TO MEET THE INTENT OF THE REQUIRED QUALIFICATIONS. FOR EACH PROJECT, LIST THE FOLLOWING:

1. WATER SYSTEM
2. APPROXIMATE DATES
3. SCOPE OF PROJECT
4. TOTAL NUMBER OF WATER SERVICE LINES REPLACED
5. NUMBER OF LEAD WATER SERVICE LINES ON THE CUSTOMER-OWNED SIDE (PRIVATE SIDE) REPLACED
6. METHODS OF SERVICE LINE INSTALLATION UTILIZED



PROJECT REFERENCE:

PROJECT NAME: _____

PROJECT LOCATION: _____

PROJECTS DATES: FROM: _____ TO: _____

TOTAL DOLLAR VALUE OF PROJECT: \$ _____

DOLLAR VALUE OF BIDDER/CONTRACTOR'S WORK: \$ _____

OWNER NAME: _____

OWNER CONTACT NAME: _____

STREET ADDRESS: _____
(Street Address, City/Town, State, and Zip Code)

TELEPHONE NO.: _____ FAX NO.: _____

EMAIL ADDRESS: _____

ENGINEER NAME: _____

ENGINEER CONTACT NAME: _____

STREET ADDRESS: _____
(Street Address, City/Town, State, and Zip Code)

TELEPHONE NO.: _____ FAX NO.: _____

EMAIL ADDRESS: _____

TOTAL NUMBER OF WATER SERVICE LINES REPLACED _____

TOTAL NUMBER OF LEAD WATER SERVICE LINES ON THE CUSTOMER-OWNED SIDE
(PRIVATE SIDE) REPLACED _____

WATER SERVICE LINE INSTALLATION METHODS USED: _____

DESCRIPTION OF THE PROJECT & WORK PERFORMED / COMMENTS / NOTES:



PROJECT REFERENCE:

PROJECT NAME: _____

PROJECT LOCATION: _____

PROJECTS DATES: FROM: _____ TO: _____

TOTAL DOLLAR VALUE OF PROJECT: \$ _____

DOLLAR VALUE OF BIDDER/CONTRACTOR'S WORK: \$ _____

OWNER NAME: _____

OWNER CONTACT NAME: _____

STREET ADDRESS: _____
(Street Address, City/Town, State, and Zip Code)

TELEPHONE NO.: _____ FAX NO.: _____

EMAIL ADDRESS: _____

ENGINEER NAME: _____

ENGINEER CONTACT NAME: _____

STREET ADDRESS: _____
(Street Address, City/Town, State, and Zip Code)

TELEPHONE NO.: _____ FAX NO.: _____

EMAIL ADDRESS: _____

TOTAL NUMBER OF WATER SERVICE LINES REPLACED _____

TOTAL NUMBER OF LEAD WATER SERVICE LINES ON THE CUSTOMER-OWNED SIDE
(PRIVATE SIDE) REPLACED _____

WATER SERVICE LINE INSTALLATION METHODS USED: _____

DESCRIPTION OF THE PROJECT & WORK PERFORMED / COMMENTS / NOTES:



PROJECT REFERENCE:

PROJECT NAME: _____

PROJECT LOCATION: _____

PROJECTS DATES: FROM: _____ TO: _____

TOTAL DOLLAR VALUE OF PROJECT: \$ _____

DOLLAR VALUE OF BIDDER/CONTRACTOR'S WORK: \$ _____

OWNER NAME: _____

OWNER CONTACT NAME: _____

STREET ADDRESS: _____
(Street Address, City/Town, State, and Zip Code)

TELEPHONE NO.: _____ FAX NO.: _____

EMAIL ADDRESS: _____

ENGINEER NAME: _____

ENGINEER CONTACT NAME: _____

STREET ADDRESS: _____
(Street Address, City/Town, State, and Zip Code)

TELEPHONE NO.: _____ FAX NO.: _____

EMAIL ADDRESS: _____

TOTAL NUMBER OF WATER SERVICE LINES REPLACED _____

TOTAL NUMBER OF LEAD WATER SERVICE LINES ON THE CUSTOMER-OWNED SIDE
(PRIVATE SIDE) REPLACED _____

WATER SERVICE LINE INSTALLATION METHODS USED: _____

DESCRIPTION OF THE PROJECT & WORK PERFORMED / COMMENTS / NOTES:



PROJECT REFERENCE:

PROJECT NAME: _____

PROJECT LOCATION: _____

PROJECTS DATES: FROM: _____ TO: _____

TOTAL DOLLAR VALUE OF PROJECT: \$ _____

DOLLAR VALUE OF BIDDER/CONTRACTOR'S WORK: \$ _____

OWNER NAME: _____

OWNER CONTACT NAME: _____

STREET ADDRESS: _____
(Street Address, City/Town, State, and Zip Code)

TELEPHONE NO.: _____ FAX NO.: _____

EMAIL ADDRESS: _____

ENGINEER NAME: _____

ENGINEER CONTACT NAME: _____

STREET ADDRESS: _____
(Street Address, City/Town, State, and Zip Code)

TELEPHONE NO.: _____ FAX NO.: _____

EMAIL ADDRESS: _____

TOTAL NUMBER OF WATER SERVICE LINES REPLACED _____

TOTAL NUMBER OF LEAD WATER SERVICE LINES ON THE CUSTOMER-OWNED SIDE
(PRIVATE SIDE) REPLACED _____

WATER SERVICE LINE INSTALLATION METHODS USED: _____

DESCRIPTION OF THE PROJECT & WORK PERFORMED / COMMENTS / NOTES:



PROJECT REFERENCE:

PROJECT NAME: _____

PROJECT LOCATION: _____

PROJECTS DATES: FROM: _____ TO: _____

TOTAL DOLLAR VALUE OF PROJECT: \$ _____

DOLLAR VALUE OF BIDDER/CONTRACTOR'S WORK: \$ _____

OWNER NAME: _____

OWNER CONTACT NAME: _____

STREET ADDRESS: _____
(Street Address, City/Town, State, and Zip Code)

TELEPHONE NO.: _____ FAX NO.: _____

EMAIL ADDRESS: _____

ENGINEER NAME: _____

ENGINEER CONTACT NAME: _____

STREET ADDRESS: _____
(Street Address, City/Town, State, and Zip Code)

TELEPHONE NO.: _____ FAX NO.: _____

EMAIL ADDRESS: _____

TOTAL NUMBER OF WATER SERVICE LINES REPLACED _____

TOTAL NUMBER OF LEAD WATER SERVICE LINES ON THE CUSTOMER-OWNED SIDE
(PRIVATE SIDE) REPLACED _____

WATER SERVICE LINE INSTALLATION METHODS USED: _____

DESCRIPTION OF THE PROJECT & WORK PERFORMED / COMMENTS / NOTES:



CERTIFICATION:

The undersigned certifies that all information provided herein on the Bidder's Qualifications forms is complete, true, and accurate.

COMPANY NAME: _____

SIGNATURE: _____

NAME (typed or printed): _____

TITLE: _____

DATE: _____

Signed and sworn to before me on this _____ day of _____, 20_____.

(Notary Public)

My commission expires: _____



**PROVIDENCE WATER
ACCELERATED LEAD SERVICE LINE REPLACEMENT PROGRAM
CONTRACT 1.4
PROJECT NO. 20234**

SECTION 00 52 00
AGREEMENT

Made and concluded this _____ day of _____, 20_____, by and between the City of Providence (acting through the Providence Water Supply Board), hereinafter called Owner or City, a municipal corporation created by the General Assembly of the State of Rhode Island, in the County of Providence, in said State, party of the first part; and [Contractor Name and Address] _____, hereinafter called Contractor, party of the second part, WITNESSETH, that the said party of the second part, in consideration of the promises and agreements herein mutually entered into, both for itself and for its Successors and Assigns, promise and agree to and with the said City that it, the said party of the second part, shall and will in a good and workmanlike manner, and to the satisfaction of the Executive Engineer of Providence Water, to be expressed in writing by said officer, at its own proper cost and expense, do and perform all the work, furnish all the materials which may be required, to wit Accelerated Lead Service Line Replacement Program – Contract 1.4 in accordance with the Contract Documents (as hereinafter defined), hereto annexed and made a part hereof, in the amount of Not to Exceed _____, which will be received and payable in accordance with the Standard General Conditions of the Construction Contract of the Contract Documents, as amended and/or modified by the Supplementary Conditions of the Contract Documents. Retainage withheld from Applications for Payment shall be five (5) percent of all completed work.

That said party of the second part, its Successors and Assigns, shall and will hold said City harmless, saved and indemnified from and against all loss, cost, damage and expense on account of all mechanics' liens, and all other liens, arising out of the services performed under this Contract Agreement and also on account of any and all other lawful claims and demands for work done or materials furnished by subcontractors, subconsultants and suppliers to party of the second part under this Contract Agreement. And also, that all

Work to be done under this Contract Agreement on the part of said party of the second part shall be fully completed and performed by December 13, 2025, unless a subsequent time extension is granted. Any work taking place after the required contract completion date will be subject to liquidated damages at a rate of \$2,000 for each day beyond the schedule.

That said party of the second part, its Successors and Assigns, acknowledge, understand and agree to perform the obligations enumerated under this Contract Agreement, subject to the provisions of Section 1006(d) of the Providence Home Rule Charter of 1980, which provides that this Contract or any Purchase Order for payment on this Contract shall be void and of no effect and that the City shall be under no obligation hereunder unless there is compliance with Sections 813(b)(3) and 1007(c)(2) of said Charter. Said sections require that prior to entering into this Contract Agreement or delivering any Purchase Order, the Board of Contract and Supply and the City Controller, respectively, shall each have ascertained that there exists a sufficient unexpended and unencumbered balance in funds appropriated and allotted for the purpose to justify the cost thereof.

That said party of the second part, its Executors, Administrators, Successors and Assigns, further acknowledge, understand and agree that all City Contracts for purchase of materials, supplies, services, equipment and property, which include a cost per unit shall also include a maximum cost for the Contract, and such maximum cost shall be used by the Board of Contract and Supply and the City Controller for compliance with Sections 813(b)(3) and 1007(c)(2) of the Providence Home Rule Charter of 1980.

And said City, party of the first part, and said party of the second part will faithfully perform said Contract Agreement in all its parts, and satisfying said City that no liens or other claims for labor done or materials furnished in the aforesaid work exist, will pay therefore the aforesaid sum, to be in full satisfaction of all claims and demands therefore, and which sum will be paid in manner aforesaid.

And it is hereby mutually understood and agreed that no payment for extra work shall or will be claimed or made unless ordered in writing by the Board of Contract and Supply and said City of Providence (acting through the Providence Water Supply Board). The said

party of the second part, by execution of the Contract Agreement, represents and warrants to said City that (1) they have examined the Contract Documents thoroughly, including all the requirements specified in the Request For Proposals, Invitation to Bid and Instructions to Bidders; (2) they have had the opportunity to visit the Project site(s) to become familiar with local conditions that may in any manner affect cost, progress or performance of the Work; (3) they are familiar with all Federal, State and local laws, ordinances, rules and regulations that may in any manner affect cost, progress or performance of the Work; (4) they have studied and carefully correlated their observations with the requirements of the Contract Documents; (5) they have had the opportunity to make additional investigations and tests as they may deem necessary to determine their Bid for performance of the Work in accordance with the time, price and other terms and conditions of the Contract Documents; (6) no additional examinations, investigations, explorations, studies, or tests are needed; (7) the Contract Documents are sufficient in scope and detail to indicate and convey understanding of all terms and conditions for performance of the Work; (8) they provided written notice of any conflict, error, ambiguity, and/or discrepancy in the Contract Documents and that the written resolution issued by formal written Addenda is acceptable; and (9) they satisfied itself as to anticipated availability and cost of labor, materials, tools, and equipment. In arriving at their Bid Prices, the said party of the second part has, as an experienced and prudent manager and contractor, exercised its reasonable judgment and expertise to include the impact of all such circumstances upon their Bid Prices and the Contract Time. Claims for additional compensation or time, by said party of the second part, because of the failure of the said party of the second part to familiarize itself with conditions under which the Work is to be performed will not be allowed.

In addition to this Contract Agreement document, the additional Contract Documents which shall constitute this Contract Agreement shall include the following:

1. Exhibit I: Bidding/Contract Documents as listed in the *Project Manual for Accelerated Lead Service Line Replacement Program (Contract 1.4)*, dated _____, prepared by CDM Smith, including but not limited to: Request For Proposals, Invitation to Bid, Instructions to Bidders, General Conditions of the Construction Contract (EJCDC Document No. C-700), Supplementary Conditions, City of Providence Terms and Conditions, Rhode Island General Laws, EPA General

Terms and Conditions, and all other Requirements and Specifications in the Project Manual; and all issued Addenda (_____). These documents are hereby incorporated into this Contract Agreement by reference; the cover page of the Project Manual is included herein as Exhibit I.

2. Exhibit II: Contractor's Original Bid and Bid Forms.
3. Exhibit III: Contractor's Certificates of Insurance.
4. Exhibit IV: Contractor's Bonds.

Said additional documents shall be interpreted in the order of priority listed above. The most recently executed addendum shall have the greatest priority.

SAMPLE



IN WITNESS WHEREOF, the parties hereto have signed and executed this Contract Agreement, the City of Providence, by _____, the Mayor thereof, hereunto duly authorized, at said Providence, Rhode Island, on the day and year first above written.

This Contract Agreement shall become effective on the day and year first above written (Effective Date of the Agreement).

SIGNED IN THE PRESENCE OF:

WITNESS TO MAYOR

CITY OF PROVIDENCE
MAYOR AND CHAIRMAN

WITNESS TO CONTRACTOR

CONTRACTOR SIGNATURE

CONTRACTOR NAME & ADDRESS

APPROVED AS TO FORM & CORRECTNESS: _____

PROVIDENCE WATER LEGAL COUNSEL

APPROVED AS TO FORM & CORRECTNESS: _____

CITY SOLICITOR

EXHIBIT I
BIDDING/CONTRACT DOCUMENTS

SAMPLE

EXHIBIT II
CONTRACTOR'S ORIGINAL BID & BID FORMS

SAMPLE

EXHIBIT III
CONTRACTOR'S CERTIFICATES OF INSURANCE

SAMPLE

EXHIBIT IV
CONTRACTOR'S BONDS

SAMPLE

PERFORMANCE BOND

<p>Contractor</p> <p>Name: [Full formal name of Contractor]</p> <p>Address <i>(principal place of business)</i>: [Address of Contractor's principal place of business]</p>	<p>Surety</p> <p>Name: [Full formal name of Surety]</p> <p>Address <i>(principal place of business)</i>: [Address of Surety's principal place of business]</p>
<p>Owner</p> <p>Name: [Full formal name of Owner]</p> <p>Mailing address <i>(principal place of business)</i>: [Address of Owner's principal place of business]</p>	<p>Contract</p> <p>Description <i>(name and location)</i>: [Owner's project/contract name, and location of the project]</p> <p>Contract Price: [Amount from Contract]</p> <p>Effective Date of Contract: [Date from Contract]</p>
<p>Bond</p> <p>Bond Amount: [Amount]</p> <p>Date of Bond: [Date]</p> <p><i>(Date of Bond cannot be earlier than Effective Date of Contract)</i></p> <p>Modifications to this Bond form: <input type="checkbox"/> None <input type="checkbox"/> See Paragraph 16</p>	
<p>Surety and Contractor, intending to be legally bound hereby, subject to the terms set forth in this Performance Bond, do each cause this Performance Bond to be duly executed by an authorized officer, agent, or representative.</p>	
Contractor as Principal	Surety
<i>(Full formal name of Contractor)</i>	<i>(Full formal name of Surety) (corporate seal)</i>
By: _____	By: _____
<i>(Signature)</i>	<i>(Signature)(Attach Power of Attorney)</i>
Name: _____	Name: _____
<i>(Printed or typed)</i>	<i>(Printed or typed)</i>
Title: _____	Title: _____
Attest: _____	Attest: _____
<i>(Signature)</i>	<i>(Signature)</i>
Name: _____	Name: _____
<i>(Printed or typed)</i>	<i>(Printed or typed)</i>
Title: _____	Title: _____
<p><i>Notes: (1) Provide supplemental execution by any additional parties, such as joint venturers. (2) Any singular reference to Contractor, Surety, Owner, or other party is considered plural where applicable.</i></p>	

1. The Contractor and Surety, jointly and severally, bind themselves, their heirs, executors, administrators, successors, and assigns to the Owner for the performance of the Construction Contract, which is incorporated herein by reference.
2. If the Contractor performs the Construction Contract, the Surety and the Contractor shall have no obligation under this Bond, except when applicable to participate in a conference as provided in Paragraph 3.
3. If there is no Owner Default under the Construction Contract, the Surety's obligation under this Bond will arise after:
 - 3.1. The Owner first provides notice to the Contractor and the Surety that the Owner is considering declaring a Contractor Default. Such notice may indicate whether the Owner is requesting a conference among the Owner, Contractor, and Surety to discuss the Contractor's performance. If the Owner does not request a conference, the Surety may, within five (5) business days after receipt of the Owner's notice, request such a conference. If the Surety timely requests a conference, the Owner shall attend. Unless the Owner agrees otherwise, any conference requested under this Paragraph 3.1 will be held within ten (10) business days of the Surety's receipt of the Owner's notice. If the Owner, the Contractor, and the Surety agree, the Contractor shall be allowed a reasonable time to perform the Construction Contract, but such an agreement does not waive the Owner's right, if any, subsequently to declare a Contractor Default;
 - 3.2. The Owner declares a Contractor Default, terminates the Construction Contract and notifies the Surety; and
 - 3.3. The Owner has agreed to pay the Balance of the Contract Price in accordance with the terms of the Construction Contract to the Surety or to a contractor selected to perform the Construction Contract.
4. Failure on the part of the Owner to comply with the notice requirement in Paragraph 3.1 does not constitute a failure to comply with a condition precedent to the Surety's obligations, or release the Surety from its obligations, except to the extent the Surety demonstrates actual prejudice.
5. When the Owner has satisfied the conditions of Paragraph 3, the Surety shall promptly and at the Surety's expense take one of the following actions:
 - 5.1. Arrange for the Contractor, with the consent of the Owner, to perform and complete the Construction Contract;
 - 5.2. Undertake to perform and complete the Construction Contract itself, through its agents or independent contractors;
 - 5.3. Obtain bids or negotiated proposals from qualified contractors acceptable to the Owner for a contract for performance and completion of the Construction Contract, arrange for a contract to be prepared for execution by the Owner and a contractor selected with the Owners concurrence, to be secured with performance and payment bonds executed by a qualified surety equivalent to the bonds issued on the Construction Contract, and pay to the Owner the amount of damages as described in Paragraph 7 in excess of the Balance of the Contract Price incurred by the Owner as a result of the Contractor Default; or

- 5.4. Waive its right to perform and complete, arrange for completion, or obtain a new contractor, and with reasonable promptness under the circumstances:
- 5.4.1 After investigation, determine the amount for which it may be liable to the Owner and, as soon as practicable after the amount is determined, make payment to the Owner; or
 - 5.4.2 Deny liability in whole or in part and notify the Owner, citing the reasons for denial.
6. If the Surety does not proceed as provided in Paragraph 5 with reasonable promptness, the Surety shall be deemed to be in default on this Bond seven days after receipt of an additional written notice from the Owner to the Surety demanding that the Surety perform its obligations under this Bond, and the Owner shall be entitled to enforce any remedy available to the Owner. If the Surety proceeds as provided in Paragraph 5.4, and the Owner refuses the payment, or the Surety has denied liability, in whole or in part, without further notice, the Owner shall be entitled to enforce any remedy available to the Owner.
7. If the Surety elects to act under Paragraph 5.1, 5.2, or 5.3, then the responsibilities of the Surety to the Owner will not be greater than those of the Contractor under the Construction Contract, and the responsibilities of the Owner to the Surety will not be greater than those of the Owner under the Construction Contract. Subject to the commitment by the Owner to pay the Balance of the Contract Price, the Surety is obligated, without duplication for:
- 7.1. the responsibilities of the Contractor for correction of defective work and completion of the Construction Contract;
 - 7.2. additional legal, design professional, and delay costs resulting from the Contractor's Default, and resulting from the actions or failure to act of the Surety under Paragraph 5; and
 - 7.3. liquidated damages, or if no liquidated damages are specified in the Construction Contract, actual damages caused by delayed performance or non-performance of the Contractor.
8. If the Surety elects to act under Paragraph 5.1, 5.3, or 5.4, the Surety's liability is limited to the amount of this Bond.
9. The Surety shall not be liable to the Owner or others for obligations of the Contractor that are unrelated to the Construction Contract, and the Balance of the Contract Price will not be reduced or set off on account of any such unrelated obligations. No right of action will accrue on this Bond to any person or entity other than the Owner or its heirs, executors, administrators, successors, and assigns.
10. The Surety hereby waives notice of any change, including changes of time, to the Construction Contract or to related subcontracts, purchase orders, and other obligations.
11. Any proceeding, legal or equitable, under this Bond must be instituted in any court of competent jurisdiction in the location in which the work or part of the work is located and must be instituted within two years after a declaration of Contractor Default or within two years after the Contractor ceased working or within two years after the Surety refuses or fails to perform its obligations under this Bond, whichever occurs first. If the provisions of this paragraph are void or prohibited by law, the minimum periods of limitations available to sureties as a defense in the jurisdiction of the suit will be applicable.

12. Notice to the Surety, the Owner, or the Contractor must be mailed or delivered to the address shown on the page on which their signature appears.
13. When this Bond has been furnished to comply with a statutory or other legal requirement in the location where the construction was to be performed, any provision in this Bond conflicting with said statutory or legal requirement will be deemed deleted therefrom and provisions conforming to such statutory or other legal requirement will be deemed incorporated herein. When so furnished, the intent is that this Bond will be construed as a statutory bond and not as a common law bond.
14. Definitions
 - 14.1. *Balance of the Contract Price*—The total amount payable by the Owner to the Contractor under the Construction Contract after all proper adjustments have been made including allowance for the Contractor for any amounts received or to be received by the Owner in settlement of insurance or other claims for damages to which the Contractor is entitled, reduced by all valid and proper payments made to or on behalf of the Contractor under the Construction Contract.
 - 14.2. *Construction Contract*—The agreement between the Owner and Contractor identified on the cover page, including all Contract Documents and changes made to the agreement and the Contract Documents.
 - 14.3. *Contractor Default*—Failure of the Contractor, which has not been remedied or waived, to perform or otherwise to comply with a material term of the Construction Contract.
 - 14.4. *Owner Default*—Failure of the Owner, which has not been remedied or waived, to pay the Contractor as required under the Construction Contract or to perform and complete or comply with the other material terms of the Construction Contract.
 - 14.5. *Contract Documents*—All the documents that comprise the agreement between the Owner and Contractor.
15. If this Bond is issued for an agreement between a contractor and subcontractor, the term Contractor in this Bond will be deemed to be Subcontractor and the term Owner will be deemed to be Contractor.
16. Modifications to this Bond are as follows: **[Describe modification or enter “None”]**

PAYMENT BOND

<p>Contractor</p> <p>Name: [Full formal name of Contractor]</p> <p>Address (<i>principal place of business</i>): [Address of Contractor's principal place of business]</p>	<p>Surety</p> <p>Name: [Full formal name of Surety]</p> <p>Address (<i>principal place of business</i>): [Address of Surety's principal place of business]</p>
<p>Owner</p> <p>Name: [Full formal name of Owner]</p> <p>Mailing address (<i>principal place of business</i>): [Address of Owner's principal place of business]</p>	<p>Contract</p> <p>Description (<i>name and location</i>): [Owner's project/contract name, and location of the project]</p> <p>Contract Price: [Amount, from Contract]</p> <p>Effective Date of Contract: [Date, from Contract]</p>
<p>Bond</p> <p>Bond Amount: [Amount]</p> <p>Date of Bond: [Date]</p> <p><i>(Date of Bond cannot be earlier than Effective Date of Contract)</i></p> <p>Modifications to this Bond form: <input type="checkbox"/> None <input type="checkbox"/> See Paragraph 18</p>	
<p>Surety and Contractor, intending to be legally bound hereby, subject to the terms set forth in this Payment Bond, do each cause this Payment Bond to be duly executed by an authorized officer, agent, or representative.</p>	
Contractor as Principal	Surety
<p>_____</p> <p><i>(Full formal name of Contractor)</i></p>	<p>_____</p> <p><i>(Full formal name of Surety) (corporate seal)</i></p>
<p>By: _____</p> <p style="text-align: center;"><i>(Signature)</i></p>	<p>By: _____</p> <p style="text-align: center;"><i>(Signature)(Attach Power of Attorney)</i></p>
<p>Name: _____</p> <p style="text-align: center;"><i>(Printed or typed)</i></p>	<p>Name: _____</p> <p style="text-align: center;"><i>(Printed or typed)</i></p>
<p>Title: _____</p>	<p>Title: _____</p>
<p>Attest: _____</p> <p style="text-align: center;"><i>(Signature)</i></p>	<p>Attest: _____</p> <p style="text-align: center;"><i>(Signature)</i></p>
<p>Name: _____</p> <p style="text-align: center;"><i>(Printed or typed)</i></p>	<p>Name: _____</p> <p style="text-align: center;"><i>(Printed or typed)</i></p>
<p>Title: _____</p>	<p>Title: _____</p>
<p><i>Notes: (1) Provide supplemental execution by any additional parties, such as joint venturers. (2) Any singular reference to Contractor, Surety, Owner, or other party is considered plural where applicable.</i></p>	

1. The Contractor and Surety, jointly and severally, bind themselves, their heirs, executors, administrators, successors, and assigns to the Owner to pay for labor, materials, and equipment furnished for use in the performance of the Construction Contract, which is incorporated herein by reference, subject to the following terms.
2. If the Contractor promptly makes payment of all sums due to Claimants, and defends, indemnifies, and holds harmless the Owner from claims, demands, liens, or suits by any person or entity seeking payment for labor, materials, or equipment furnished for use in the performance of the Construction Contract, then the Surety and the Contractor shall have no obligation under this Bond.
3. If there is no Owner Default under the Construction Contract, the Surety's obligation to the Owner under this Bond will arise after the Owner has promptly notified the Contractor and the Surety (at the address described in Paragraph 13) of claims, demands, liens, or suits against the Owner or the Owner's property by any person or entity seeking payment for labor, materials, or equipment furnished for use in the performance of the Construction Contract, and tendered defense of such claims, demands, liens, or suits to the Contractor and the Surety.
4. When the Owner has satisfied the conditions in Paragraph 3, the Surety shall promptly and at the Surety's expense defend, indemnify, and hold harmless the Owner against a duly tendered claim, demand, lien, or suit.
5. The Surety's obligations to a Claimant under this Bond will arise after the following:
 - 5.1. Claimants who do not have a direct contract with the Contractor
 - 5.1.1. have furnished a written notice of non-payment to the Contractor, stating with substantial accuracy the amount claimed and the name of the party to whom the materials were, or equipment was, furnished or supplied or for whom the labor was done or performed, within ninety (90) days after having last performed labor or last furnished materials or equipment included in the Claim; and
 - 5.1.2. have sent a Claim to the Surety (at the address described in Paragraph 13).
 - 5.2. Claimants who are employed by or have a direct contract with the Contractor have sent a Claim to the Surety (at the address described in Paragraph 13).
6. If a notice of non-payment required by Paragraph 5.1.1 is given by the Owner to the Contractor, that is sufficient to satisfy a Claimant's obligation to furnish a written notice of non-payment under Paragraph 5.1.1.
7. When a Claimant has satisfied the conditions of Paragraph 5.1 or 5.2, whichever is applicable, the Surety shall promptly and at the Surety's expense take the following actions:
 - 7.1. Send an answer to the Claimant, with a copy to the Owner, within sixty (60) days after receipt of the Claim, stating the amounts that are undisputed and the basis for challenging any amounts that are disputed; and
 - 7.2. Pay or arrange for payment of any undisputed amounts.
 - 7.3. The Surety's failure to discharge its obligations under Paragraph 7.1 or 7.2 will not be deemed to constitute a waiver of defenses the Surety or Contractor may have or acquire as to a Claim, except as to undisputed amounts for which the Surety and Claimant have reached agreement. If, however, the Surety fails to discharge its obligations under Paragraph 7.1 or 7.2, the Surety

shall indemnify the Claimant for the reasonable attorney's fees the Claimant incurs thereafter to recover any sums found to be due and owing to the Claimant.

8. The Surety's total obligation will not exceed the amount of this Bond, plus the amount of reasonable attorney's fees provided under Paragraph 7.3, and the amount of this Bond will be credited for any payments made in good faith by the Surety.
9. Amounts owed by the Owner to the Contractor under the Construction Contract will be used for the performance of the Construction Contract and to satisfy claims, if any, under any construction performance bond. By the Contractor furnishing and the Owner accepting this Bond, they agree that all funds earned by the Contractor in the performance of the Construction Contract are dedicated to satisfying obligations of the Contractor and Surety under this Bond, subject to the Owner's priority to use the funds for the completion of the work.
10. The Surety shall not be liable to the Owner, Claimants, or others for obligations of the Contractor that are unrelated to the Construction Contract. The Owner shall not be liable for the payment of any costs or expenses of any Claimant under this Bond, and shall have under this Bond no obligation to make payments to or give notice on behalf of Claimants, or otherwise have any obligations to Claimants under this Bond.
11. The Surety hereby waives notice of any change, including changes of time, to the Construction Contract or to related subcontracts, purchase orders, and other obligations.
12. No suit or action will be commenced by a Claimant under this Bond other than in a court of competent jurisdiction in the state in which the project that is the subject of the Construction Contract is located or after the expiration of one year from the date (1) on which the Claimant sent a Claim to the Surety pursuant to Paragraph 5.1.2 or 5.2, or (2) on which the last labor or service was performed by anyone or the last materials or equipment were furnished by anyone under the Construction Contract, whichever of (1) or (2) first occurs. If the provisions of this paragraph are void or prohibited by law, the minimum period of limitation available to sureties as a defense in the jurisdiction of the suit will be applicable.
13. Notice and Claims to the Surety, the Owner, or the Contractor must be mailed or delivered to the address shown on the page on which their signature appears. Actual receipt of notice or Claims, however accomplished, will be sufficient compliance as of the date received.
14. When this Bond has been furnished to comply with a statutory or other legal requirement in the location where the construction was to be performed, any provision in this Bond conflicting with said statutory or legal requirement will be deemed deleted here from and provisions conforming to such statutory or other legal requirement will be deemed incorporated herein. When so furnished, the intent is that this Bond will be construed as a statutory bond and not as a common law bond.
15. Upon requests by any person or entity appearing to be a potential beneficiary of this Bond, the Contractor and Owner shall promptly furnish a copy of this Bond or shall permit a copy to be made.

16. Definitions

16.1. *Claim*—A written statement by the Claimant including at a minimum:

16.1.1. The name of the Claimant;

16.1.2. The name of the person for whom the labor was done, or materials or equipment furnished;

- 16.1.3. A copy of the agreement or purchase order pursuant to which labor, materials, or equipment was furnished for use in the performance of the Construction Contract;
 - 16.1.4. A brief description of the labor, materials, or equipment furnished;
 - 16.1.5. The date on which the Claimant last performed labor or last furnished materials or equipment for use in the performance of the Construction Contract;
 - 16.1.6. The total amount earned by the Claimant for labor, materials, or equipment furnished as of the date of the Claim;
 - 16.1.7. The total amount of previous payments received by the Claimant; and
 - 16.1.8. The total amount due and unpaid to the Claimant for labor, materials, or equipment furnished as of the date of the Claim.
- 16.2. *Claimant*—An individual or entity having a direct contract with the Contractor or with a subcontractor of the Contractor to furnish labor, materials, or equipment for use in the performance of the Construction Contract. The term Claimant also includes any individual or entity that has rightfully asserted a claim under an applicable mechanic’s lien or similar statute against the real property upon which the Project is located. The intent of this Bond is to include without limitation in the terms of “labor, materials, or equipment” that part of the water, gas, power, light, heat, oil, gasoline, telephone service, or rental equipment used in the Construction Contract, architectural and engineering services required for performance of the work of the Contractor and the Contractor’s subcontractors, and all other items for which a mechanic’s lien may be asserted in the jurisdiction where the labor, materials, or equipment were furnished.
- 16.3. *Construction Contract*—The agreement between the Owner and Contractor identified on the cover page, including all Contract Documents and all changes made to the agreement and the Contract Documents.
- 16.4. *Owner Default*—Failure of the Owner, which has not been remedied or waived, to pay the Contractor as required under the Construction Contract or to perform and complete or comply with the other material terms of the Construction Contract.
- 16.5. *Contract Documents*—All the documents that comprise the agreement between the Owner and Contractor.
17. If this Bond is issued for an agreement between a contractor and subcontractor, the term Contractor in this Bond will be deemed to be Subcontractor and the term Owner will be deemed to be Contractor.
18. Modifications to this Bond are as follows: **[Describe modification or enter “None”]**

This document has important legal consequences; consultation with an attorney is encouraged with respect to its use or modification. This document should be adapted to the particular circumstances of the contemplated Project and the controlling Laws and Regulations.

STANDARD GENERAL CONDITIONS OF THE CONSTRUCTION CONTRACT

Prepared By



Endorsed By



Copyright© 2018

National Society of Professional Engineers
1420 King Street, Alexandria, VA 22314-2794
(703) 684-2882
www.nspe.org

American Council of Engineering Companies
1015 15th Street N.W., Washington, DC 20005
(202) 347-7474
www.acec.org

American Society of Civil Engineers
1801 Alexander Bell Drive, Reston, VA 20191-4400
(800) 548-2723
www.asce.org

The copyright for this EJCDC document is owned jointly by the three sponsoring organizations listed above. The National Society of Professional Engineers is the Copyright Administrator for the EJCDC documents; please direct all inquiries regarding EJCDC copyrights to NSPE.

NOTE: EJCDC publications may be purchased at www.ejcdc.org, or from any of the sponsoring organizations above.

GUIDELINES FOR USE OF EJCDC® C-700, STANDARD GENERAL CONDITIONS OF THE CONSTRUCTION CONTRACT

1.0 PURPOSE AND INTENDED USE OF THE DOCUMENT

EJCDC® C-700, Standard General Conditions of the Construction Contract (2018), is the foundation document for the EJCDC Construction Series. The General Conditions define the basic rights, responsibilities, risk allocations, and contractual relationship of the Owner and Contractor, and establish how the Contract is to be administered.

2.0 OTHER DOCUMENTS

EJCDC documents are intended to be used as a system and changes in one EJCDC document may require a corresponding change in other documents. Other EJCDC documents may also serve as a reference to provide insight or guidance for the preparation of this document.

These General Conditions have been prepared for use with either EJCDC® C-520, Agreement Between Owner and Contractor for Construction Contract (Stipulated Price), or EJCDC® C-525, Agreement Between Owner and Contractor for Construction Contract (Cost-Plus-Fee) (2018 Editions). The provisions of the General Conditions and the Agreement are interrelated, and a change in one may necessitate a change in the other.

To prepare supplementary conditions that are coordinated with the General Conditions, use EJCDC® C-800, Supplementary Conditions of the Construction Contract (2018).

The full EJCDC Construction series of documents is discussed in the EJCDC® C-001, Commentary on the 2018 EJCDC Construction Documents (2018).

3.0 ORGANIZATION OF INFORMATION

All parties involved in a construction project benefit significantly from a standardized approach in the location of subject matter throughout the documents. Experience confirms the danger of addressing the same subject matter in more than one location; doing so frequently leads to confusion and unanticipated legal consequences. Careful attention should be given to the guidance provided in EJCDC® N-122/AIA® A521, Uniform Location of Subject Matter (2012 Edition) when preparing documents. EJCDC® N-122/AIA® A521 is available at no charge from the EJCDC website, www.ejcdc.org, and from the websites of EJCDC's sponsoring organizations.

If CSI MasterFormat™ is used for organizing the Project Manual, consult CSI MasterFormat™ for the appropriate document number (e.g., under 00 11 00, Advertisements and Invitations), and accordingly number the document and its pages.

4.0 EDITING THIS DOCUMENT

Remove these Guidelines for Use. Some users may also prefer to remove the two cover pages.

Although it is permissible to revise the Standard EJCDC Text of C-700 (the content beginning at page 1 and continuing to the end), it is common practice to leave the Standard EJCDC Text of C-700 intact and unaltered, with modifications and supplementation of C-700's provisions set forth in EJCDC® C-800, Supplementary Conditions of the Construction Contract (2018). If the Standard Text itself is revised, the

user must comply with the terms of the License Agreement, Paragraph 4.0, Document-Specific Provisions, concerning the tracking or highlighting of revisions. The following is a summary of the relevant License Agreement provisions:

1. The term “Standard EJCDC Text” for C-700 refers to all text prepared by EJCDC in the main body of the document. Document covers, logos, footers, instructions, or copyright notices are not Standard EJCDC Text for this purpose.
2. During the drafting or negotiating process for C-700, it is important that the two contracting parties are both aware of any changes that have been made to the Standard EJCDC Text. Thus, if a draft or version of C-700 purports to be or appears to be an EJCDC document, the user must plainly show all changes to the Standard EJCDC Text, using “Track Changes” (redline/strikeout), highlighting, or other means of clearly indicating additions and deletions.
3. If C-700 has been revised or altered and is subsequently presented to third parties (such as potential bidders, grant agencies, lenders, or sureties) as an EJCDC document, then the changes to the Standard EJCDC Text must be shown, or the third parties must receive access to a version that shows the changes.
4. Once the document is ready to be finalized (and if applicable executed by the contracting parties), it is no longer necessary to continue to show changes to the Standard EJCDC Text. The user may produce a final version of the document in a format in which all changes are accepted, and the document at that point does not need to include any “Track Changes,” redline/strikeout, highlighting, or other indication of additions and deletions to the Standard EJCDC Text.

5.0 LICENSE AGREEMENT

This document is subject to the terms and conditions of the **License Agreement, 2018 EJCDC® Construction Series Documents**. A copy of the License Agreement was furnished at the time of purchase of this document, and is available for review at www.ejcdc.org and the websites of EJCDC’s sponsoring organizations.

STANDARD GENERAL CONDITIONS OF THE CONSTRUCTION CONTRACT

TABLE OF CONTENTS

	Page
Article 1—Definitions and Terminology	1
1.01 Defined Terms	1
1.02 Terminology	6
Article 2—Preliminary Matters	7
2.01 Delivery of Performance and Payment Bonds; Evidence of Insurance	7
2.02 Copies of Documents	7
2.03 Before Starting Construction	7
2.04 Preconstruction Conference; Designation of Authorized Representatives	8
2.05 Acceptance of Schedules	8
2.06 Electronic Transmittals	8
Article 3—Contract Documents: Intent, Requirements, Reuse	9
3.01 Intent	9
3.02 Reference Standards	9
3.03 Reporting and Resolving Discrepancies	10
3.04 Requirements of the Contract Documents	10
3.05 Reuse of Documents	11
Article 4—Commencement and Progress of the Work	11
4.01 Commencement of Contract Times; Notice to Proceed	11
4.02 Starting the Work	11
4.03 Reference Points	11
4.04 Progress Schedule	12
4.05 Delays in Contractor’s Progress	12
Article 5—Site; Subsurface and Physical Conditions; Hazardous Environmental Conditions	13
5.01 Availability of Lands	13
5.02 Use of Site and Other Areas	14
5.03 Subsurface and Physical Conditions	15
5.04 Differing Subsurface or Physical Conditions	16

5.05	Underground Facilities.....	17
5.06	Hazardous Environmental Conditions at Site	19
Article 6—Bonds and Insurance		21
6.01	Performance, Payment, and Other Bonds.....	21
6.02	Insurance—General Provisions.....	22
6.03	Contractor’s Insurance	24
6.04	Builder’s Risk and Other Property Insurance.....	25
6.05	Property Losses; Subrogation	25
6.06	Receipt and Application of Property Insurance Proceeds	27
Article 7—Contractor’s Responsibilities		27
7.01	Contractor’s Means and Methods of Construction	27
7.02	Supervision and Superintendence	27
7.03	Labor; Working Hours.....	27
7.04	Services, Materials, and Equipment	28
7.05	“Or Equals”	28
7.06	Substitutes	29
7.07	Concerning Subcontractors and Suppliers.....	31
7.08	Patent Fees and Royalties.....	32
7.09	Permits.....	33
7.10	Taxes.....	33
7.11	Laws and Regulations	33
7.12	Record Documents	33
7.13	Safety and Protection	34
7.14	Hazard Communication Programs.....	35
7.15	Emergencies.....	35
7.16	Submittals.....	35
7.17	Contractor’s General Warranty and Guarantee	38
7.18	Indemnification.....	39
7.19	Delegation of Professional Design Services	39
Article 8—Other Work at the Site		40
8.01	Other Work.....	40
8.02	Coordination	41
8.03	Legal Relationships	41

Article 9—Owner’s Responsibilities.....	42
9.01 Communications to Contractor	42
9.02 Replacement of Engineer.....	42
9.03 Furnish Data.....	42
9.04 Pay When Due	42
9.05 Lands and Easements; Reports, Tests, and Drawings.....	43
9.06 Insurance	43
9.07 Change Orders	43
9.08 Inspections, Tests, and Approvals.....	43
9.09 Limitations on Owner’s Responsibilities	43
9.10 Undisclosed Hazardous Environmental Condition.....	43
9.11 Evidence of Financial Arrangements	43
9.12 Safety Programs.....	43
Article 10—Engineer’s Status During Construction	44
10.01 Owner’s Representative	44
10.02 Visits to Site	44
10.03 Resident Project Representative	44
10.04 Engineer’s Authority	44
10.05 Determinations for Unit Price Work	45
10.06 Decisions on Requirements of Contract Documents and Acceptability of Work	45
10.07 Limitations on Engineer’s Authority and Responsibilities.....	45
10.08 Compliance with Safety Program	45
Article 11—Changes to the Contract.....	46
11.01 Amending and Supplementing the Contract	46
11.02 Change Orders	46
11.03 Work Change Directives.....	46
11.04 Field Orders	47
11.05 Owner-Authorized Changes in the Work.....	47
11.06 Unauthorized Changes in the Work.....	47
11.07 Change of Contract Price	47
11.08 Change of Contract Times.....	49
11.09 Change Proposals.....	49
11.10 Notification to Surety	50

Article 12—Claims	50
12.01 Claims	50
Article 13—Cost of the Work; Allowances; Unit Price Work	51
13.01 Cost of the Work.....	51
13.02 Allowances.....	55
13.03 Unit Price Work.....	55
Article 14—Tests and Inspections; Correction, Removal, or Acceptance of Defective Work.....	56
14.01 Access to Work	56
14.02 Tests, Inspections, and Approvals.....	56
14.03 Defective Work	57
14.04 Acceptance of Defective Work	58
14.05 Uncovering Work	58
14.06 Owner May Stop the Work	58
14.07 Owner May Correct Defective Work	59
Article 15—Payments to Contractor; Set-Offs; Completion; Correction Period.....	59
15.01 Progress Payments	59
15.02 Contractor’s Warranty of Title.....	62
15.03 Substantial Completion.....	62
15.04 Partial Use or Occupancy	63
15.05 Final Inspection.....	64
15.06 Final Payment	64
15.07 Waiver of Claims	65
15.08 Correction Period.....	66
Article 16—Suspension of Work and Termination	67
16.01 Owner May Suspend Work	67
16.02 Owner May Terminate for Cause.....	67
16.03 Owner May Terminate for Convenience	68
16.04 Contractor May Stop Work or Terminate	68
Article 17—Final Resolution of Disputes	69
17.01 Methods and Procedures	69
Article 18—Miscellaneous.....	69
18.01 Giving Notice.....	69
18.02 Computation of Times	69

18.03	Cumulative Remedies	70
18.04	Limitation of Damages.....	70
18.05	No Waiver	70
18.06	Survival of Obligations	70
18.07	Controlling Law	70
18.08	Assignment of Contract	70
18.09	Successors and Assigns	70
18.10	Headings	70

STANDARD GENERAL CONDITIONS OF THE CONSTRUCTION CONTRACT

ARTICLE 1—DEFINITIONS AND TERMINOLOGY

1.01 *Defined Terms*

- A. Wherever used in the Bidding Requirements or Contract Documents, a term printed with initial capital letters, including the term's singular and plural forms, will have the meaning indicated in the definitions below. In addition to terms specifically defined, terms with initial capital letters in the Contract Documents include references to identified articles and paragraphs, and the titles of other documents or forms.
1. *Addenda*—Written or graphic instruments issued prior to the opening of Bids which clarify, correct, or change the Bidding Requirements or the proposed Contract Documents.
 2. *Agreement*—The written instrument, executed by Owner and Contractor, that sets forth the Contract Price and Contract Times, identifies the parties and the Engineer, and designates the specific items that are Contract Documents.
 3. *Application for Payment*—The document prepared by Contractor, in a form acceptable to Engineer, to request progress or final payments, and which is to be accompanied by such supporting documentation as is required by the Contract Documents.
 4. *Bid*—The offer of a Bidder submitted on the prescribed form setting forth the prices for the Work to be performed.
 5. *Bidder*—An individual or entity that submits a Bid to Owner.
 6. *Bidding Documents*—The Bidding Requirements, the proposed Contract Documents, and all Addenda.
 7. *Bidding Requirements*—The Advertisement or invitation to bid, Instructions to Bidders, Bid Bond or other Bid security, if any, the Bid Form, and the Bid with any attachments.
 8. *Change Order*—A document which is signed by Contractor and Owner and authorizes an addition, deletion, or revision in the Work or an adjustment in the Contract Price or the Contract Times, or other revision to the Contract, issued on or after the Effective Date of the Contract.
 9. *Change Proposal*—A written request by Contractor, duly submitted in compliance with the procedural requirements set forth herein, seeking an adjustment in Contract Price or Contract Times; contesting an initial decision by Engineer concerning the requirements of the Contract Documents or the acceptability of Work under the Contract Documents; challenging a set-off against payments due; or seeking other relief with respect to the terms of the Contract.
 10. *Claim*
 - a. A demand or assertion by Owner directly to Contractor, duly submitted in compliance with the procedural requirements set forth herein, seeking an adjustment of Contract Price or Contract Times; contesting an initial decision by Engineer concerning the

- requirements of the Contract Documents or the acceptability of Work under the Contract Documents; contesting Engineer's decision regarding a Change Proposal; seeking resolution of a contractual issue that Engineer has declined to address; or seeking other relief with respect to the terms of the Contract.
- b. A demand or assertion by Contractor directly to Owner, duly submitted in compliance with the procedural requirements set forth herein, contesting Engineer's decision regarding a Change Proposal, or seeking resolution of a contractual issue that Engineer has declined to address.
 - c. A demand or assertion by Owner or Contractor, duly submitted in compliance with the procedural requirements set forth herein, made pursuant to Paragraph 12.01.A.4, concerning disputes arising after Engineer has issued a recommendation of final payment.
 - d. A demand for money or services by a third party is not a Claim.
11. *Constituent of Concern*—Asbestos, petroleum, radioactive materials, polychlorinated biphenyls (PCBs), lead-based paint (as defined by the HUD/EPA standard), hazardous waste, and any substance, product, waste, or other material of any nature whatsoever that is or becomes listed, regulated, or addressed pursuant to Laws and Regulations regulating, relating to, or imposing liability or standards of conduct concerning, any hazardous, toxic, or dangerous waste, substance, or material.
12. *Contract*—The entire and integrated written contract between Owner and Contractor concerning the Work.
13. *Contract Documents*—Those items so designated in the Agreement, and which together comprise the Contract.
14. *Contract Price*—The money that Owner has agreed to pay Contractor for completion of the Work in accordance with the Contract Documents.
15. *Contract Times*—The number of days or the dates by which Contractor shall: (a) achieve Milestones, if any; (b) achieve Substantial Completion; and (c) complete the Work.
16. *Contractor*—The individual or entity with which Owner has contracted for performance of the Work.
17. *Cost of the Work*—See Paragraph 13.01 for definition.
18. *Drawings*—The part of the Contract that graphically shows the scope, extent, and character of the Work to be performed by Contractor.
19. *Effective Date of the Contract*—The date, indicated in the Agreement, on which the Contract becomes effective.
20. *Electronic Document*—Any Project-related correspondence, attachments to correspondence, data, documents, drawings, information, or graphics, including but not limited to Shop Drawings and other Submittals, that are in an electronic or digital format.
21. *Electronic Means*—Electronic mail (email), upload/download from a secure Project website, or other communications methods that allow: (a) the transmission or communication of Electronic Documents; (b) the documentation of transmissions, including sending and receipt; (c) printing of the transmitted Electronic Document by the

recipient; (d) the storage and archiving of the Electronic Document by sender and recipient; and (e) the use by recipient of the Electronic Document for purposes permitted by this Contract. Electronic Means does not include the use of text messaging, or of Facebook, Twitter, Instagram, or similar social media services for transmission of Electronic Documents.

22. *Engineer*—The individual or entity named as such in the Agreement.
23. *Field Order*—A written order issued by Engineer which requires minor changes in the Work but does not change the Contract Price or the Contract Times.
24. *Hazardous Environmental Condition*—The presence at the Site of Constituents of Concern in such quantities or circumstances that may present a danger to persons or property exposed thereto.
 - a. The presence at the Site of materials that are necessary for the execution of the Work, or that are to be incorporated into the Work, and that are controlled and contained pursuant to industry practices, Laws and Regulations, and the requirements of the Contract, is not a Hazardous Environmental Condition.
 - b. The presence of Constituents of Concern that are to be removed or remediated as part of the Work is not a Hazardous Environmental Condition.
 - c. The presence of Constituents of Concern as part of the routine, anticipated, and obvious working conditions at the Site, is not a Hazardous Environmental Condition.
25. *Laws and Regulations; Laws or Regulations*—Any and all applicable laws, statutes, rules, regulations, ordinances, codes, and binding decrees, resolutions, and orders of any and all governmental bodies, agencies, authorities, and courts having jurisdiction.
26. *Liens*—Charges, security interests, or encumbrances upon Contract-related funds, real property, or personal property.
27. *Milestone*—A principal event in the performance of the Work that the Contract requires Contractor to achieve by an intermediate completion date, or by a time prior to Substantial Completion of all the Work.
28. *Notice of Award*—The written notice by Owner to a Bidder of Owner's acceptance of the Bid.
29. *Notice to Proceed*—A written notice by Owner to Contractor fixing the date on which the Contract Times will commence to run and on which Contractor shall start to perform the Work.
30. *Owner*—The individual or entity with which Contractor has contracted regarding the Work, and which has agreed to pay Contractor for the performance of the Work, pursuant to the terms of the Contract.
31. *Progress Schedule*—A schedule, prepared and maintained by Contractor, describing the sequence and duration of the activities comprising Contractor's plan to accomplish the Work within the Contract Times.
32. *Project*—The total undertaking to be accomplished for Owner by engineers, contractors, and others, including planning, study, design, construction, testing, commissioning, and start-up, and of which the Work to be performed under the Contract Documents is a part.

33. *Resident Project Representative*—The authorized representative of Engineer assigned to assist Engineer at the Site. As used herein, the term Resident Project Representative (RPR) includes any assistants or field staff of Resident Project Representative.
34. *Samples*—Physical examples of materials, equipment, or workmanship that are representative of some portion of the Work and that establish the standards by which such portion of the Work will be judged.
35. *Schedule of Submittals*—A schedule, prepared and maintained by Contractor, of required submittals and the time requirements for Engineer’s review of the submittals.
36. *Schedule of Values*—A schedule, prepared and maintained by Contractor, allocating portions of the Contract Price to various portions of the Work and used as the basis for reviewing Contractor’s Applications for Payment.
37. *Shop Drawings*—All drawings, diagrams, illustrations, schedules, and other data or information that are specifically prepared or assembled by or for Contractor and submitted by Contractor to illustrate some portion of the Work. Shop Drawings, whether approved or not, are not Drawings and are not Contract Documents.
38. *Site*—Lands or areas indicated in the Contract Documents as being furnished by Owner upon which the Work is to be performed, including rights-of-way and easements, and such other lands or areas furnished by Owner which are designated for the use of Contractor.
39. *Specifications*—The part of the Contract that consists of written requirements for materials, equipment, systems, standards, and workmanship as applied to the Work, and certain administrative requirements and procedural matters applicable to the Work.
40. *Subcontractor*—An individual or entity having a direct contract with Contractor or with any other Subcontractor for the performance of a part of the Work.
41. *Submittal*—A written or graphic document, prepared by or for Contractor, which the Contract Documents require Contractor to submit to Engineer, or that is indicated as a Submittal in the Schedule of Submittals accepted by Engineer. Submittals may include Shop Drawings and Samples; schedules; product data; Owner-delegated designs; sustainable design information; information on special procedures; testing plans; results of tests and evaluations, source quality-control testing and inspections, and field or Site quality-control testing and inspections; warranties and certifications; Suppliers’ instructions and reports; records of delivery of spare parts and tools; operations and maintenance data; Project photographic documentation; record documents; and other such documents required by the Contract Documents. Submittals, whether or not approved or accepted by Engineer, are not Contract Documents. Change Proposals, Change Orders, Claims, notices, Applications for Payment, and requests for interpretation or clarification are not Submittals.
42. *Substantial Completion*—The time at which the Work (or a specified part thereof) has progressed to the point where, in the opinion of Engineer, the Work (or a specified part thereof) is sufficiently complete, in accordance with the Contract Documents, so that the Work (or a specified part thereof) can be utilized for the purposes for which it is intended. The terms “substantially complete” and “substantially completed” as applied to all or part of the Work refer to Substantial Completion of such Work.

43. *Successful Bidder*—The Bidder to which the Owner makes an award of contract.
44. *Supplementary Conditions*—The part of the Contract that amends or supplements these General Conditions.
45. *Supplier*—A manufacturer, fabricator, supplier, distributor, or vendor having a direct contract with Contractor or with any Subcontractor to furnish materials or equipment to be incorporated in the Work by Contractor or a Subcontractor.
46. *Technical Data*
- a. Those items expressly identified as Technical Data in the Supplementary Conditions, with respect to either (1) existing subsurface conditions at or adjacent to the Site, or existing physical conditions at or adjacent to the Site including existing surface or subsurface structures (except Underground Facilities) or (2) Hazardous Environmental Conditions at the Site.
 - b. If no such express identifications of Technical Data have been made with respect to conditions at the Site, then Technical Data is defined, with respect to conditions at the Site under Paragraphs 5.03, 5.04, and 5.06, as the data contained in boring logs, recorded measurements of subsurface water levels, assessments of the condition of subsurface facilities, laboratory test results, and other factual, objective information regarding conditions at the Site that are set forth in any geotechnical, environmental, or other Site or facilities conditions report prepared for the Project and made available to Contractor.
 - c. Information and data regarding the presence or location of Underground Facilities are not intended to be categorized, identified, or defined as Technical Data, and instead Underground Facilities are shown or indicated on the Drawings.
47. *Underground Facilities*—All active or not-in-service underground lines, pipelines, conduits, ducts, encasements, cables, wires, manholes, vaults, tanks, tunnels, or other such facilities or systems at the Site, including but not limited to those facilities or systems that produce, transmit, distribute, or convey telephone or other communications, cable television, fiber optic transmissions, power, electricity, light, heat, gases, oil, crude oil products, liquid petroleum products, water, steam, waste, wastewater, storm water, other liquids or chemicals, or traffic or other control systems. An abandoned facility or system is not an Underground Facility.
48. *Unit Price Work*—Work to be paid for on the basis of unit prices.
49. *Work*—The entire construction or the various separately identifiable parts thereof required to be provided under the Contract Documents. Work includes and is the result of performing or providing all labor, services, and documentation necessary to produce such construction; furnishing, installing, and incorporating all materials and equipment into such construction; and may include related services such as testing, start-up, and commissioning, all as required by the Contract Documents.
50. *Work Change Directive*—A written directive to Contractor issued on or after the Effective Date of the Contract, signed by Owner and recommended by Engineer, ordering an addition, deletion, or revision in the Work.

1.02 Terminology

- A. The words and terms discussed in Paragraphs 1.02.B, C, D, and E are not defined terms that require initial capital letters, but, when used in the Bidding Requirements or Contract Documents, have the indicated meaning.
- B. *Intent of Certain Terms or Adjectives:* The Contract Documents include the terms “as allowed,” “as approved,” “as ordered,” “as directed” or terms of like effect or import to authorize an exercise of professional judgment by Engineer. In addition, the adjectives “reasonable,” “suitable,” “acceptable,” “proper,” “satisfactory,” or adjectives of like effect or import are used to describe an action or determination of Engineer as to the Work. It is intended that such exercise of professional judgment, action, or determination will be solely to evaluate, in general, the Work for compliance with the information in the Contract Documents and with the design concept of the Project as a functioning whole as shown or indicated in the Contract Documents (unless there is a specific statement indicating otherwise). The use of any such term or adjective is not intended to and shall not be effective to assign to Engineer any duty or authority to supervise or direct the performance of the Work, or any duty or authority to undertake responsibility contrary to the provisions of Article 10 or any other provision of the Contract Documents.
- C. *Day:* The word “day” means a calendar day of 24 hours measured from midnight to the next midnight.
- D. *Defective:* The word “defective,” when modifying the word “Work,” refers to Work that is unsatisfactory, faulty, or deficient in that it:
 - 1. does not conform to the Contract Documents;
 - 2. does not meet the requirements of any applicable inspection, reference standard, test, or approval referred to in the Contract Documents; or
 - 3. has been damaged prior to Engineer’s recommendation of final payment (unless responsibility for the protection thereof has been assumed by Owner at Substantial Completion in accordance with Paragraph 15.03 or Paragraph 15.04).
- E. *Furnish, Install, Perform, Provide*
 - 1. The word “furnish,” when used in connection with services, materials, or equipment, means to supply and deliver said services, materials, or equipment to the Site (or some other specified location) ready for use or installation and in usable or operable condition.
 - 2. The word “install,” when used in connection with services, materials, or equipment, means to put into use or place in final position said services, materials, or equipment complete and ready for intended use.
 - 3. The words “perform” or “provide,” when used in connection with services, materials, or equipment, means to furnish and install said services, materials, or equipment complete and ready for intended use.
 - 4. If the Contract Documents establish an obligation of Contractor with respect to specific services, materials, or equipment, but do not expressly use any of the four words “furnish,” “install,” “perform,” or “provide,” then Contractor shall furnish and install said services, materials, or equipment complete and ready for intended use.

- F. *Contract Price or Contract Times*: References to a change in “Contract Price or Contract Times” or “Contract Times or Contract Price” or similar, indicate that such change applies to (1) Contract Price, (2) Contract Times, or (3) both Contract Price and Contract Times, as warranted, even if the term “or both” is not expressed.
- G. Unless stated otherwise in the Contract Documents, words or phrases that have a well-known technical or construction industry or trade meaning are used in the Contract Documents in accordance with such recognized meaning.

ARTICLE 2—PRELIMINARY MATTERS

2.01 *Delivery of Performance and Payment Bonds; Evidence of Insurance*

- A. *Performance and Payment Bonds*: When Contractor delivers the signed counterparts of the Agreement to Owner, Contractor shall also deliver to Owner the performance bond and payment bond (if the Contract requires Contractor to furnish such bonds).
- B. *Evidence of Contractor’s Insurance*: When Contractor delivers the signed counterparts of the Agreement to Owner, Contractor shall also deliver to Owner, with copies to each additional insured (as identified in the Contract), the certificates, endorsements, and other evidence of insurance required to be provided by Contractor in accordance with Article 6, except to the extent the Supplementary Conditions expressly establish other dates for delivery of specific insurance policies.
- C. *Evidence of Owner’s Insurance*: After receipt of the signed counterparts of the Agreement and all required bonds and insurance documentation, Owner shall promptly deliver to Contractor, with copies to each additional insured (as identified in the Contract), the certificates and other evidence of insurance required to be provided by Owner under Article 6.

2.02 *Copies of Documents*

- A. Owner shall furnish to Contractor four printed copies of the Contract (including one fully signed counterpart of the Agreement), and one copy in electronic portable document format (PDF). Additional printed copies will be furnished upon request at the cost of reproduction.
- B. Owner shall maintain and safeguard at least one original printed record version of the Contract, including Drawings and Specifications signed and sealed by Engineer and other design professionals. Owner shall make such original printed record version of the Contract available to Contractor for review. Owner may delegate the responsibilities under this provision to Engineer.

2.03 *Before Starting Construction*

- A. *Preliminary Schedules*: Within 10 days after the Effective Date of the Contract (or as otherwise required by the Contract Documents), Contractor shall submit to Engineer for timely review:
 - 1. a preliminary Progress Schedule indicating the times (numbers of days or dates) for starting and completing the various stages of the Work, including any Milestones specified in the Contract;
 - 2. a preliminary Schedule of Submittals; and
 - 3. a preliminary Schedule of Values for all of the Work which includes quantities and prices of items which when added together equal the Contract Price and subdivides the Work

into component parts in sufficient detail to serve as the basis for progress payments during performance of the Work. Such prices will include an appropriate amount of overhead and profit applicable to each item of Work.

2.04 *Preconstruction Conference; Designation of Authorized Representatives*

- A. Before any Work at the Site is started, a conference attended by Owner, Contractor, Engineer, and others as appropriate will be held to establish a working understanding among the parties as to the Work, and to discuss the schedules referred to in Paragraph 2.03.A, procedures for handling Shop Drawings, Samples, and other Submittals, processing Applications for Payment, electronic or digital transmittals, and maintaining required records.
- B. At this conference Owner and Contractor each shall designate, in writing, a specific individual to act as its authorized representative with respect to the services and responsibilities under the Contract. Such individuals shall have the authority to transmit and receive information, render decisions relative to the Contract, and otherwise act on behalf of each respective party.

2.05 *Acceptance of Schedules*

- A. At least 10 days before submission of the first Application for Payment a conference, attended by Contractor, Engineer, and others as appropriate, will be held to review the schedules submitted in accordance with Paragraph 2.03.A. No progress payment will be made to Contractor until acceptable schedules are submitted to Engineer.
 - 1. The Progress Schedule will be acceptable to Engineer if it provides an orderly progression of the Work to completion within the Contract Times. Such acceptance will not impose on Engineer responsibility for the Progress Schedule, for sequencing, scheduling, or progress of the Work, nor interfere with or relieve Contractor from Contractor's full responsibility therefor.
 - 2. Contractor's Schedule of Submittals will be acceptable to Engineer if it provides a workable arrangement for reviewing and processing the required submittals.
 - 3. Contractor's Schedule of Values will be acceptable to Engineer as to form and substance if it provides a reasonable allocation of the Contract Price to the component parts of the Work.
 - 4. If a schedule is not acceptable, Contractor will have an additional 10 days to revise and resubmit the schedule.

2.06 *Electronic Transmittals*

- A. Except as otherwise stated elsewhere in the Contract, the Owner, Engineer, and Contractor may send, and shall accept, Electronic Documents transmitted by Electronic Means.
- B. If the Contract does not establish protocols for Electronic Means, then Owner, Engineer, and Contractor shall jointly develop such protocols.
- C. Subject to any governing protocols for Electronic Means, when transmitting Electronic Documents by Electronic Means, the transmitting party makes no representations as to long-term compatibility, usability, or readability of the Electronic Documents resulting from the recipient's use of software application packages, operating systems, or computer hardware differing from those used in the drafting or transmittal of the Electronic Documents.

ARTICLE 3—CONTRACT DOCUMENTS: INTENT, REQUIREMENTS, REUSE

3.01 *Intent*

- A. The Contract Documents are complementary; what is required by one Contract Document is as binding as if required by all.
- B. It is the intent of the Contract Documents to describe a functionally complete Project (or part thereof) to be constructed in accordance with the Contract Documents.
- C. Unless otherwise stated in the Contract Documents, if there is a discrepancy between the electronic versions of the Contract Documents (including any printed copies derived from such electronic versions) and the printed record version, the printed record version will govern.
- D. The Contract supersedes prior negotiations, representations, and agreements, whether written or oral.
- E. Engineer will issue clarifications and interpretations of the Contract Documents as provided herein.
- F. Any provision or part of the Contract Documents held to be void or unenforceable under any Law or Regulation will be deemed stricken, and all remaining provisions will continue to be valid and binding upon Owner and Contractor, which agree that the Contract Documents will be reformed to replace such stricken provision or part thereof with a valid and enforceable provision that comes as close as possible to expressing the intention of the stricken provision.
- G. Nothing in the Contract Documents creates:
 - 1. any contractual relationship between Owner or Engineer and any Subcontractor, Supplier, or other individual or entity performing or furnishing any of the Work, for the benefit of such Subcontractor, Supplier, or other individual or entity; or
 - 2. any obligation on the part of Owner or Engineer to pay or to see to the payment of any money due any such Subcontractor, Supplier, or other individual or entity, except as may otherwise be required by Laws and Regulations.

3.02 *Reference Standards*

- A. *Standards Specifications, Codes, Laws and Regulations*
 - 1. Reference in the Contract Documents to standard specifications, manuals, reference standards, or codes of any technical society, organization, or association, or to Laws or Regulations, whether such reference be specific or by implication, means the standard specification, manual, reference standard, code, or Laws or Regulations in effect at the time of opening of Bids (or on the Effective Date of the Contract if there were no Bids), except as may be otherwise specifically stated in the Contract Documents.
 - 2. No provision of any such standard specification, manual, reference standard, or code, and no instruction of a Supplier, will be effective to change the duties or responsibilities of Owner, Contractor, or Engineer from those set forth in the part of the Contract Documents prepared by or for Engineer. No such provision or instruction shall be effective to assign to Owner or Engineer any duty or authority to supervise or direct the performance of the Work, or any duty or authority to undertake responsibility

inconsistent with the provisions of the part of the Contract Documents prepared by or for Engineer.

3.03 *Reporting and Resolving Discrepancies*

A. *Reporting Discrepancies*

1. *Contractor's Verification of Figures and Field Measurements:* Before undertaking each part of the Work, Contractor shall carefully study the Contract Documents, and check and verify pertinent figures and dimensions therein, particularly with respect to applicable field measurements. Contractor shall promptly report in writing to Engineer any conflict, error, ambiguity, or discrepancy that Contractor discovers, or has actual knowledge of, and shall not proceed with any Work affected thereby until the conflict, error, ambiguity, or discrepancy is resolved by a clarification or interpretation by Engineer, or by an amendment or supplement to the Contract issued pursuant to Paragraph 11.01.
2. *Contractor's Review of Contract Documents:* If, before or during the performance of the Work, Contractor discovers any conflict, error, ambiguity, or discrepancy within the Contract Documents, or between the Contract Documents and (a) any applicable Law or Regulation, (b) actual field conditions, (c) any standard specification, manual, reference standard, or code, or (d) any instruction of any Supplier, then Contractor shall promptly report it to Engineer in writing. Contractor shall not proceed with the Work affected thereby (except in an emergency as required by Paragraph 7.15) until the conflict, error, ambiguity, or discrepancy is resolved, by a clarification or interpretation by Engineer, or by an amendment or supplement to the Contract issued pursuant to Paragraph 11.01.
3. Contractor shall not be liable to Owner or Engineer for failure to report any conflict, error, ambiguity, or discrepancy in the Contract Documents unless Contractor had actual knowledge thereof.

B. *Resolving Discrepancies*

1. Except as may be otherwise specifically stated in the Contract Documents, the provisions of the part of the Contract Documents prepared by or for Engineer take precedence in resolving any conflict, error, ambiguity, or discrepancy between such provisions of the Contract Documents and:
 - a. the provisions of any standard specification, manual, reference standard, or code, or the instruction of any Supplier (whether or not specifically incorporated by reference as a Contract Document); or
 - b. the provisions of any Laws or Regulations applicable to the performance of the Work (unless such an interpretation of the provisions of the Contract Documents would result in violation of such Law or Regulation).

3.04 *Requirements of the Contract Documents*

- A. During the performance of the Work and until final payment, Contractor and Owner shall submit to the Engineer in writing all matters in question concerning the requirements of the Contract Documents (sometimes referred to as requests for information or interpretation—RFIs), or relating to the acceptability of the Work under the Contract Documents, as soon as possible after such matters arise. Engineer will be the initial interpreter of the requirements of the Contract Documents, and judge of the acceptability of the Work.

- B. Engineer will, with reasonable promptness, render a written clarification, interpretation, or decision on the issue submitted, or initiate an amendment or supplement to the Contract Documents. Engineer's written clarification, interpretation, or decision will be final and binding on Contractor, unless it appeals by submitting a Change Proposal, and on Owner, unless it appeals by filing a Claim.
- C. If a submitted matter in question concerns terms and conditions of the Contract Documents that do not involve (1) the performance or acceptability of the Work under the Contract Documents, (2) the design (as set forth in the Drawings, Specifications, or otherwise), or (3) other engineering or technical matters, then Engineer will promptly notify Owner and Contractor in writing that Engineer is unable to provide a decision or interpretation. If Owner and Contractor are unable to agree on resolution of such a matter in question, either party may pursue resolution as provided in Article 12.

3.05 *Reuse of Documents*

- A. Contractor and its Subcontractors and Suppliers shall not:
 - 1. have or acquire any title to or ownership rights in any of the Drawings, Specifications, or other documents (or copies of any thereof) prepared by or bearing the seal of Engineer or its consultants, including electronic media versions, or reuse any such Drawings, Specifications, other documents, or copies thereof on extensions of the Project or any other project without written consent of Owner and Engineer and specific written verification or adaptation by Engineer; or
 - 2. have or acquire any title or ownership rights in any other Contract Documents, reuse any such Contract Documents for any purpose without Owner's express written consent, or violate any copyrights pertaining to such Contract Documents.
- B. The prohibitions of this Paragraph 3.05 will survive final payment, or termination of the Contract. Nothing herein precludes Contractor from retaining copies of the Contract Documents for record purposes.

ARTICLE 4—COMMENCEMENT AND PROGRESS OF THE WORK

4.01 *Commencement of Contract Times; Notice to Proceed*

- A. The Contract Times will commence to run on the 30th day after the Effective Date of the Contract or, if a Notice to Proceed is given, on the day indicated in the Notice to Proceed. A Notice to Proceed may be given at any time within 30 days after the Effective Date of the Contract. In no event will the Contract Times commence to run later than the 60th day after the day of Bid opening or the 30th day after the Effective Date of the Contract, whichever date is earlier.

4.02 *Starting the Work*

- A. Contractor shall start to perform the Work on the date when the Contract Times commence to run. No Work may be done at the Site prior to such date.

4.03 *Reference Points*

- A. Owner shall provide engineering surveys to establish reference points for construction which in Engineer's judgment are necessary to enable Contractor to proceed with the Work. Contractor shall be responsible for laying out the Work, shall protect and preserve the

established reference points and property monuments, and shall make no changes or relocations without the prior written approval of Owner. Contractor shall report to Engineer whenever any reference point or property monument is lost or destroyed or requires relocation because of necessary changes in grades or locations, and shall be responsible for the accurate replacement or relocation of such reference points or property monuments by professionally qualified personnel.

4.04 *Progress Schedule*

- A. Contractor shall adhere to the Progress Schedule established in accordance with Paragraph 2.05 as it may be adjusted from time to time as provided below.
 - 1. Contractor shall submit to Engineer for acceptance (to the extent indicated in Paragraph 2.05) proposed adjustments in the Progress Schedule that will not result in changing the Contract Times.
 - 2. Proposed adjustments in the Progress Schedule that will change the Contract Times must be submitted in accordance with the requirements of Article 11.
- B. Contractor shall carry on the Work and adhere to the Progress Schedule during all disputes or disagreements with Owner. No Work will be delayed or postponed pending resolution of any disputes or disagreements, or during any appeal process, except as permitted by Paragraph 16.04, or as Owner and Contractor may otherwise agree in writing.

4.05 *Delays in Contractor's Progress*

- A. If Owner, Engineer, or anyone for whom Owner is responsible, delays, disrupts, or interferes with the performance or progress of the Work, then Contractor shall be entitled to an equitable adjustment in Contract Price or Contract Times.
- B. Contractor shall not be entitled to an adjustment in Contract Price or Contract Times for delay, disruption, or interference caused by or within the control of Contractor. Delay, disruption, and interference attributable to and within the control of a Subcontractor or Supplier shall be deemed to be within the control of Contractor.
- C. If Contractor's performance or progress is delayed, disrupted, or interfered with by unanticipated causes not the fault of and beyond the control of Owner, Contractor, and those for which they are responsible, then Contractor shall be entitled to an equitable adjustment in Contract Times. Such an adjustment will be Contractor's sole and exclusive remedy for the delays, disruption, and interference described in this paragraph. Causes of delay, disruption, or interference that may give rise to an adjustment in Contract Times under this paragraph include but are not limited to the following:
 - 1. Severe and unavoidable natural catastrophes such as fires, floods, epidemics, and earthquakes;
 - 2. Abnormal weather conditions;
 - 3. Acts or failures to act of third-party utility owners or other third-party entities (other than those third-party utility owners or other third-party entities performing other work at or adjacent to the Site as arranged by or under contract with Owner, as contemplated in Article 8); and
 - 4. Acts of war or terrorism.

- D. Contractor's entitlement to an adjustment of Contract Times or Contract Price is limited as follows:
1. Contractor's entitlement to an adjustment of the Contract Times is conditioned on the delay, disruption, or interference adversely affecting an activity on the critical path to completion of the Work, as of the time of the delay, disruption, or interference.
 2. Contractor shall not be entitled to an adjustment in Contract Price for any delay, disruption, or interference if such delay is concurrent with a delay, disruption, or interference caused by or within the control of Contractor. Such a concurrent delay by Contractor shall not preclude an adjustment of Contract Times to which Contractor is otherwise entitled.
 3. Adjustments of Contract Times or Contract Price are subject to the provisions of Article 11.
- E. Each Contractor request or Change Proposal seeking an increase in Contract Times or Contract Price must be supplemented by supporting data that sets forth in detail the following:
1. The circumstances that form the basis for the requested adjustment;
 2. The date upon which each cause of delay, disruption, or interference began to affect the progress of the Work;
 3. The date upon which each cause of delay, disruption, or interference ceased to affect the progress of the Work;
 4. The number of days' increase in Contract Times claimed as a consequence of each such cause of delay, disruption, or interference; and
 5. The impact on Contract Price, in accordance with the provisions of Paragraph 11.07.
- Contractor shall also furnish such additional supporting documentation as Owner or Engineer may require including, where appropriate, a revised progress schedule indicating all the activities affected by the delay, disruption, or interference, and an explanation of the effect of the delay, disruption, or interference on the critical path to completion of the Work.
- F. Delays, disruption, and interference to the performance or progress of the Work resulting from the existence of a differing subsurface or physical condition, an Underground Facility that was not shown or indicated by the Contract Documents, or not shown or indicated with reasonable accuracy, and those resulting from Hazardous Environmental Conditions, are governed by Article 5, together with the provisions of Paragraphs 4.05.D and 4.05.E.
- G. Paragraph 8.03 addresses delays, disruption, and interference to the performance or progress of the Work resulting from the performance of certain other work at or adjacent to the Site.

ARTICLE 5—SITE; SUBSURFACE AND PHYSICAL CONDITIONS; HAZARDOUS ENVIRONMENTAL CONDITIONS

5.01 *Availability of Lands*

- A. Owner shall furnish the Site. Owner shall notify Contractor in writing of any encumbrances or restrictions not of general application but specifically related to use of the Site with which Contractor must comply in performing the Work.

- B. Upon reasonable written request, Owner shall furnish Contractor with a current statement of record legal title and legal description of the lands upon which permanent improvements are to be made and Owner's interest therein as necessary for giving notice of or filing a mechanic's or construction lien against such lands in accordance with applicable Laws and Regulations.
- C. Contractor shall provide for all additional lands and access thereto that may be required for temporary construction facilities or storage of materials and equipment.

5.02 *Use of Site and Other Areas*

A. *Limitation on Use of Site and Other Areas*

1. Contractor shall confine construction equipment, temporary construction facilities, the storage of materials and equipment, and the operations of workers to the Site, adjacent areas that Contractor has arranged to use through construction easements or otherwise, and other adjacent areas permitted by Laws and Regulations, and shall not unreasonably encumber the Site and such other adjacent areas with construction equipment or other materials or equipment. Contractor shall assume full responsibility for (a) damage to the Site; (b) damage to any such other adjacent areas used for Contractor's operations; (c) damage to any other adjacent land or areas, or to improvements, structures, utilities, or similar facilities located at such adjacent lands or areas; and (d) for injuries and losses sustained by the owners or occupants of any such land or areas; provided that such damage or injuries result from the performance of the Work or from other actions or conduct of the Contractor or those for which Contractor is responsible.
 2. If a damage or injury claim is made by the owner or occupant of any such land or area because of the performance of the Work, or because of other actions or conduct of the Contractor or those for which Contractor is responsible, Contractor shall (a) take immediate corrective or remedial action as required by Paragraph 7.13, or otherwise; (b) promptly attempt to settle the claim as to all parties through negotiations with such owner or occupant, or otherwise resolve the claim by arbitration or other dispute resolution proceeding, or in a court of competent jurisdiction; and (c) to the fullest extent permitted by Laws and Regulations, indemnify and hold harmless Owner and Engineer, and the officers, directors, members, partners, employees, agents, consultants and subcontractors of each and any of them, from and against any such claim, and against all costs, losses, and damages (including but not limited to all fees and charges of engineers, architects, attorneys, and other professionals and all court or arbitration or other dispute resolution costs) arising out of or relating to any claim or action, legal or equitable, brought by any such owner or occupant against Owner, Engineer, or any other party indemnified hereunder to the extent caused directly or indirectly, in whole or in part by, or based upon, Contractor's performance of the Work, or because of other actions or conduct of the Contractor or those for which Contractor is responsible.
- B. *Removal of Debris During Performance of the Work:* During the progress of the Work the Contractor shall keep the Site and other adjacent areas free from accumulations of waste materials, rubbish, and other debris. Removal and disposal of such waste materials, rubbish, and other debris will conform to applicable Laws and Regulations.
 - C. *Cleaning:* Prior to Substantial Completion of the Work Contractor shall clean the Site and the Work and make it ready for utilization by Owner. At the completion of the Work Contractor shall remove from the Site and adjacent areas all tools, appliances, construction equipment

and machinery, and surplus materials and shall restore to original condition all property not designated for alteration by the Contract Documents.

- D. *Loading of Structures:* Contractor shall not load nor permit any part of any structure to be loaded in any manner that will endanger the structure, nor shall Contractor subject any part of the Work or adjacent structures or land to stresses or pressures that will endanger them.

5.03 *Subsurface and Physical Conditions*

- A. *Reports and Drawings:* The Supplementary Conditions identify:

1. Those reports of explorations and tests of subsurface conditions at or adjacent to the Site that contain Technical Data;
2. Those drawings of existing physical conditions at or adjacent to the Site, including those drawings depicting existing surface or subsurface structures at or adjacent to the Site (except Underground Facilities), that contain Technical Data; and
3. Technical Data contained in such reports and drawings.

- B. *Underground Facilities:* Underground Facilities are shown or indicated on the Drawings, pursuant to Paragraph 5.05, and not in the drawings referred to in Paragraph 5.03.A. Information and data regarding the presence or location of Underground Facilities are not intended to be categorized, identified, or defined as Technical Data.

- C. *Reliance by Contractor on Technical Data:* Contractor may rely upon the accuracy of the Technical Data expressly identified in the Supplementary Conditions with respect to such reports and drawings, but such reports and drawings are not Contract Documents. If no such express identification has been made, then Contractor may rely upon the accuracy of the Technical Data as defined in Paragraph 1.01.A.46.b.

- D. *Limitations of Other Data and Documents:* Except for such reliance on Technical Data, Contractor may not rely upon or make any claim against Owner or Engineer, or any of their officers, directors, members, partners, employees, agents, consultants, or subcontractors, with respect to:

1. the completeness of such reports and drawings for Contractor's purposes, including, but not limited to, any aspects of the means, methods, techniques, sequences, and procedures of construction to be employed by Contractor, and safety precautions and programs incident thereto;
2. other data, interpretations, opinions, and information contained in such reports or shown or indicated in such drawings;
3. the contents of other Site-related documents made available to Contractor, such as record drawings from other projects at or adjacent to the Site, or Owner's archival documents concerning the Site; or
4. any Contractor interpretation of or conclusion drawn from any Technical Data or any such other data, interpretations, opinions, or information.

5.04 *Differing Subsurface or Physical Conditions*

- A. *Notice by Contractor:* If Contractor believes that any subsurface or physical condition that is uncovered or revealed at the Site:
1. is of such a nature as to establish that any Technical Data on which Contractor is entitled to rely as provided in Paragraph 5.03 is materially inaccurate;
 2. is of such a nature as to require a change in the Drawings or Specifications;
 3. differs materially from that shown or indicated in the Contract Documents; or
 4. is of an unusual nature, and differs materially from conditions ordinarily encountered and generally recognized as inherent in work of the character provided for in the Contract Documents;

then Contractor shall, promptly after becoming aware thereof and before further disturbing the subsurface or physical conditions or performing any Work in connection therewith (except in an emergency as required by Paragraph 7.15), notify Owner and Engineer in writing about such condition. Contractor shall not further disturb such condition or perform any Work in connection therewith (except with respect to an emergency) until receipt of a written statement permitting Contractor to do so.

- B. *Engineer's Review:* After receipt of written notice as required by the preceding paragraph, Engineer will promptly review the subsurface or physical condition in question; determine whether it is necessary for Owner to obtain additional exploration or tests with respect to the condition; conclude whether the condition falls within any one or more of the differing site condition categories in Paragraph 5.04.A; obtain any pertinent cost or schedule information from Contractor; prepare recommendations to Owner regarding the Contractor's resumption of Work in connection with the subsurface or physical condition in question and the need for any change in the Drawings or Specifications; and advise Owner in writing of Engineer's findings, conclusions, and recommendations.
- C. *Owner's Statement to Contractor Regarding Site Condition:* After receipt of Engineer's written findings, conclusions, and recommendations, Owner shall issue a written statement to Contractor (with a copy to Engineer) regarding the subsurface or physical condition in question, addressing the resumption of Work in connection with such condition, indicating whether any change in the Drawings or Specifications will be made, and adopting or rejecting Engineer's written findings, conclusions, and recommendations, in whole or in part.
- D. *Early Resumption of Work:* If at any time Engineer determines that Work in connection with the subsurface or physical condition in question may resume prior to completion of Engineer's review or Owner's issuance of its statement to Contractor, because the condition in question has been adequately documented, and analyzed on a preliminary basis, then the Engineer may at its discretion instruct Contractor to resume such Work.
- E. *Possible Price and Times Adjustments*
1. Contractor shall be entitled to an equitable adjustment in Contract Price or Contract Times, to the extent that the existence of a differing subsurface or physical condition, or any related delay, disruption, or interference, causes an increase or decrease in

Contractor's cost of, or time required for, performance of the Work; subject, however, to the following:

- a. Such condition must fall within any one or more of the categories described in Paragraph 5.04.A;
 - b. With respect to Work that is paid for on a unit price basis, any adjustment in Contract Price will be subject to the provisions of Paragraph 13.03; and,
 - c. Contractor's entitlement to an adjustment of the Contract Times is subject to the provisions of Paragraphs 4.05.D and 4.05.E.
2. Contractor shall not be entitled to any adjustment in the Contract Price or Contract Times with respect to a subsurface or physical condition if:
- a. Contractor knew of the existence of such condition at the time Contractor made a commitment to Owner with respect to Contract Price and Contract Times by the submission of a Bid or becoming bound under a negotiated contract, or otherwise;
 - b. The existence of such condition reasonably could have been discovered or revealed as a result of any examination, investigation, exploration, test, or study of the Site and contiguous areas expressly required by the Bidding Requirements or Contract Documents to be conducted by or for Contractor prior to Contractor's making such commitment; or
 - c. Contractor failed to give the written notice required by Paragraph 5.04.A.
3. If Owner and Contractor agree regarding Contractor's entitlement to and the amount or extent of any adjustment in the Contract Price or Contract Times, then any such adjustment will be set forth in a Change Order.
4. Contractor may submit a Change Proposal regarding its entitlement to or the amount or extent of any adjustment in the Contract Price or Contract Times, no later than 30 days after Owner's issuance of the Owner's written statement to Contractor regarding the subsurface or physical condition in question.
- F. *Underground Facilities; Hazardous Environmental Conditions:* Paragraph 5.05 governs rights and responsibilities regarding the presence or location of Underground Facilities. Paragraph 5.06 governs rights and responsibilities regarding Hazardous Environmental Conditions. The provisions of Paragraphs 5.03 and 5.04 are not applicable to the presence or location of Underground Facilities, or to Hazardous Environmental Conditions.

5.05 *Underground Facilities*

- A. *Contractor's Responsibilities:* Unless it is otherwise expressly provided in the Supplementary Conditions, the cost of all of the following are included in the Contract Price, and Contractor shall have full responsibility for:
1. reviewing and checking all information and data regarding existing Underground Facilities at the Site;
 2. complying with applicable state and local utility damage prevention Laws and Regulations;

3. verifying the actual location of those Underground Facilities shown or indicated in the Contract Documents as being within the area affected by the Work, by exposing such Underground Facilities during the course of construction;
 4. coordination of the Work with the owners (including Owner) of such Underground Facilities, during construction; and
 5. the safety and protection of all existing Underground Facilities at the Site, and repairing any damage thereto resulting from the Work.
- B. *Notice by Contractor:* If Contractor believes that an Underground Facility that is uncovered or revealed at the Site was not shown or indicated on the Drawings, or was not shown or indicated on the Drawings with reasonable accuracy, then Contractor shall, promptly after becoming aware thereof and before further disturbing conditions affected thereby or performing any Work in connection therewith (except in an emergency as required by Paragraph 7.15), notify Owner and Engineer in writing regarding such Underground Facility.
- C. *Engineer's Review:* Engineer will:
1. promptly review the Underground Facility and conclude whether such Underground Facility was not shown or indicated on the Drawings, or was not shown or indicated with reasonable accuracy;
 2. identify and communicate with the owner of the Underground Facility; prepare recommendations to Owner (and if necessary issue any preliminary instructions to Contractor) regarding the Contractor's resumption of Work in connection with the Underground Facility in question;
 3. obtain any pertinent cost or schedule information from Contractor; determine the extent, if any, to which a change is required in the Drawings or Specifications to reflect and document the consequences of the existence or location of the Underground Facility; and
 4. advise Owner in writing of Engineer's findings, conclusions, and recommendations.

During such time, Contractor shall be responsible for the safety and protection of such Underground Facility.

- D. *Owner's Statement to Contractor Regarding Underground Facility:* After receipt of Engineer's written findings, conclusions, and recommendations, Owner shall issue a written statement to Contractor (with a copy to Engineer) regarding the Underground Facility in question addressing the resumption of Work in connection with such Underground Facility, indicating whether any change in the Drawings or Specifications will be made, and adopting or rejecting Engineer's written findings, conclusions, and recommendations in whole or in part.
- E. *Early Resumption of Work:* If at any time Engineer determines that Work in connection with the Underground Facility may resume prior to completion of Engineer's review or Owner's issuance of its statement to Contractor, because the Underground Facility in question and conditions affected by its presence have been adequately documented, and analyzed on a preliminary basis, then the Engineer may at its discretion instruct Contractor to resume such Work.
- F. *Possible Price and Times Adjustments*
1. Contractor shall be entitled to an equitable adjustment in the Contract Price or Contract Times, to the extent that any existing Underground Facility at the Site that was not shown

or indicated on the Drawings, or was not shown or indicated with reasonable accuracy, or any related delay, disruption, or interference, causes an increase or decrease in Contractor's cost of, or time required for, performance of the Work; subject, however, to the following:

- a. With respect to Work that is paid for on a unit price basis, any adjustment in Contract Price will be subject to the provisions of Paragraph 13.03;
 - b. Contractor's entitlement to an adjustment of the Contract Times is subject to the provisions of Paragraphs 4.05.D and 4.05.E; and
 - c. Contractor gave the notice required in Paragraph 5.05.B.
2. If Owner and Contractor agree regarding Contractor's entitlement to and the amount or extent of any adjustment in the Contract Price or Contract Times, then any such adjustment will be set forth in a Change Order.
 3. Contractor may submit a Change Proposal regarding its entitlement to or the amount or extent of any adjustment in the Contract Price or Contract Times, no later than 30 days after Owner's issuance of the Owner's written statement to Contractor regarding the Underground Facility in question.
 4. The information and data shown or indicated on the Drawings with respect to existing Underground Facilities at the Site is based on information and data (a) furnished by the owners of such Underground Facilities, or by others, (b) obtained from available records, or (c) gathered in an investigation conducted in accordance with the current edition of ASCE 38, Standard Guideline for the Collection and Depiction of Existing Subsurface Utility Data, by the American Society of Civil Engineers. If such information or data is incorrect or incomplete, Contractor's remedies are limited to those set forth in this Paragraph 5.05.F.

5.06 *Hazardous Environmental Conditions at Site*

A. *Reports and Drawings*: The Supplementary Conditions identify:

1. those reports known to Owner relating to Hazardous Environmental Conditions that have been identified at or adjacent to the Site;
2. drawings known to Owner relating to Hazardous Environmental Conditions that have been identified at or adjacent to the Site; and
3. Technical Data contained in such reports and drawings.

B. *Reliance by Contractor on Technical Data Authorized*: Contractor may rely upon the accuracy of the Technical Data expressly identified in the Supplementary Conditions with respect to such reports and drawings, but such reports and drawings are not Contract Documents. If no such express identification has been made, then Contractor may rely on the accuracy of the Technical Data as defined in Paragraph 1.01.A.46.b. Except for such reliance on Technical Data, Contractor may not rely upon or make any claim against Owner or Engineer, or any of their officers, directors, members, partners, employees, agents, consultants, or subcontractors, with respect to:

1. the completeness of such reports and drawings for Contractor's purposes, including, but not limited to, any aspects of the means, methods, techniques, sequences and procedures

- of construction to be employed by Contractor, and safety precautions and programs incident thereto;
2. other data, interpretations, opinions, and information contained in such reports or shown or indicated in such drawings; or
 3. any Contractor interpretation of or conclusion drawn from any Technical Data or any such other data, interpretations, opinions or information.
- C. Contractor shall not be responsible for removing or remediating any Hazardous Environmental Condition encountered, uncovered, or revealed at the Site unless such removal or remediation is expressly identified in the Contract Documents to be within the scope of the Work.
- D. Contractor shall be responsible for controlling, containing, and duly removing all Constituents of Concern brought to the Site by Contractor, Subcontractors, Suppliers, or anyone else for whom Contractor is responsible, and for any associated costs; and for the costs of removing and remediating any Hazardous Environmental Condition created by the presence of any such Constituents of Concern.
- E. If Contractor encounters, uncovers, or reveals a Hazardous Environmental Condition whose removal or remediation is not expressly identified in the Contract Documents as being within the scope of the Work, or if Contractor or anyone for whom Contractor is responsible creates a Hazardous Environmental Condition, then Contractor shall immediately: (1) secure or otherwise isolate such condition; (2) stop all Work in connection with such condition and in any area affected thereby (except in an emergency as required by Paragraph 7.15); and (3) notify Owner and Engineer (and promptly thereafter confirm such notice in writing). Owner shall promptly consult with Engineer concerning the necessity for Owner to retain a qualified expert to evaluate such condition or take corrective action, if any. Promptly after consulting with Engineer, Owner shall take such actions as are necessary to permit Owner to timely obtain required permits and provide Contractor the written notice required by Paragraph 5.06.F. If Contractor or anyone for whom Contractor is responsible created the Hazardous Environmental Condition in question, then Owner may remove and remediate the Hazardous Environmental Condition, and impose a set-off against payments to account for the associated costs.
- F. Contractor shall not resume Work in connection with such Hazardous Environmental Condition or in any affected area until after Owner has obtained any required permits related thereto, and delivered written notice to Contractor either (1) specifying that such condition and any affected area is or has been rendered safe for the resumption of Work, or (2) specifying any special conditions under which such Work may be resumed safely.
- G. If Owner and Contractor cannot agree as to entitlement to or on the amount or extent, if any, of any adjustment in Contract Price or Contract Times, as a result of such Work stoppage, such special conditions under which Work is agreed to be resumed by Contractor, or any costs or expenses incurred in response to the Hazardous Environmental Condition, then within 30 days of Owner's written notice regarding the resumption of Work, Contractor may submit a Change Proposal, or Owner may impose a set-off. Entitlement to any such adjustment is subject to the provisions of Paragraphs 4.05.D, 4.05.E, 11.07, and 11.08.
- H. If, after receipt of such written notice, Contractor does not agree to resume such Work based on a reasonable belief it is unsafe, or does not agree to resume such Work under such special

conditions, then Owner may order the portion of the Work that is in the area affected by such condition to be deleted from the Work, following the contractual change procedures in Article 11. Owner may have such deleted portion of the Work performed by Owner's own forces or others in accordance with Article 8.

- I. To the fullest extent permitted by Laws and Regulations, Owner shall indemnify and hold harmless Contractor, Subcontractors, and Engineer, and the officers, directors, members, partners, employees, agents, consultants, and subcontractors of each and any of them, from and against all claims, costs, losses, and damages (including but not limited to all fees and charges of engineers, architects, attorneys, and other professionals, and all court, arbitration, or other dispute resolution costs) arising out of or relating to a Hazardous Environmental Condition, provided that such Hazardous Environmental Condition (1) was not shown or indicated in the Drawings, Specifications, or other Contract Documents, identified as Technical Data entitled to limited reliance pursuant to Paragraph 5.06.B, or identified in the Contract Documents to be included within the scope of the Work, and (2) was not created by Contractor or by anyone for whom Contractor is responsible. Nothing in this Paragraph 5.06.I obligates Owner to indemnify any individual or entity from and against the consequences of that individual's or entity's own negligence.
- J. To the fullest extent permitted by Laws and Regulations, Contractor shall indemnify and hold harmless Owner and Engineer, and the officers, directors, members, partners, employees, agents, consultants, and subcontractors of each and any of them, from and against all claims, costs, losses, and damages (including but not limited to all fees and charges of engineers, architects, attorneys, and other professionals and all court or arbitration or other dispute resolution costs) arising out of or relating to the failure to control, contain, or remove a Constituent of Concern brought to the Site by Contractor or by anyone for whom Contractor is responsible, or to a Hazardous Environmental Condition created by Contractor or by anyone for whom Contractor is responsible. Nothing in this Paragraph 5.06.J obligates Contractor to indemnify any individual or entity from and against the consequences of that individual's or entity's own negligence.
- K. The provisions of Paragraphs 5.03, 5.04, and 5.05 do not apply to the presence of Constituents of Concern or to a Hazardous Environmental Condition uncovered or revealed at the Site.

ARTICLE 6—BONDS AND INSURANCE

6.01 *Performance, Payment, and Other Bonds*

- A. Contractor shall furnish a performance bond and a payment bond, each in an amount at least equal to the Contract Price, as security for the faithful performance and payment of Contractor's obligations under the Contract. These bonds must remain in effect until one year after the date when final payment becomes due or until completion of the correction period specified in Paragraph 15.08, whichever is later, except as provided otherwise by Laws or Regulations, the terms of a prescribed bond form, the Supplementary Conditions, or other provisions of the Contract.
- B. Contractor shall also furnish such other bonds (if any) as are required by the Supplementary Conditions or other provisions of the Contract.
- C. All bonds must be in the form included in the Bidding Documents or otherwise specified by Owner prior to execution of the Contract, except as provided otherwise by Laws or

Regulations, and must be issued and signed by a surety named in “Companies Holding Certificates of Authority as Acceptable Sureties on Federal Bonds and as Acceptable Reinsuring Companies” as published in Department Circular 570 (as amended and supplemented) by the Bureau of the Fiscal Service, U.S. Department of the Treasury. A bond signed by an agent or attorney-in-fact must be accompanied by a certified copy of that individual’s authority to bind the surety. The evidence of authority must show that it is effective on the date the agent or attorney-in-fact signed the accompanying bond.

- D. Contractor shall obtain the required bonds from surety companies that are duly licensed or authorized, in the state or jurisdiction in which the Project is located, to issue bonds in the required amounts.
- E. If the surety on a bond furnished by Contractor is declared bankrupt or becomes insolvent, or the surety ceases to meet the requirements above, then Contractor shall promptly notify Owner and Engineer in writing and shall, within 20 days after the event giving rise to such notification, provide another bond and surety, both of which must comply with the bond and surety requirements above.
- F. If Contractor has failed to obtain a required bond, Owner may exclude the Contractor from the Site and exercise Owner’s termination rights under Article 16.
- G. Upon request to Owner from any Subcontractor, Supplier, or other person or entity claiming to have furnished labor, services, materials, or equipment used in the performance of the Work, Owner shall provide a copy of the payment bond to such person or entity.
- H. Upon request to Contractor from any Subcontractor, Supplier, or other person or entity claiming to have furnished labor, services, materials, or equipment used in the performance of the Work, Contractor shall provide a copy of the payment bond to such person or entity.

6.02 *Insurance—General Provisions*

- A. Owner and Contractor shall obtain and maintain insurance as required in this article and in the Supplementary Conditions.
- B. All insurance required by the Contract to be purchased and maintained by Owner or Contractor shall be obtained from insurance companies that are duly licensed or authorized in the state or jurisdiction in which the Project is located to issue insurance policies for the required limits and coverages. Unless a different standard is indicated in the Supplementary Conditions, all companies that provide insurance policies required under this Contract shall have an A.M. Best rating of A-VII or better.
- C. Alternative forms of insurance coverage, including but not limited to self-insurance and “Occupational Accident and Excess Employer’s Indemnity Policies,” are not sufficient to meet the insurance requirements of this Contract, unless expressly allowed in the Supplementary Conditions.
- D. Contractor shall deliver to Owner, with copies to each additional insured identified in the Contract, certificates of insurance and endorsements establishing that Contractor has obtained and is maintaining the policies and coverages required by the Contract. Upon request by Owner or any other insured, Contractor shall also furnish other evidence of such required insurance, including but not limited to copies of policies, documentation of applicable self-insured retentions (if allowed) and deductibles, full disclosure of all relevant exclusions, and evidence of insurance required to be purchased and maintained by

Subcontractors or Suppliers. In any documentation furnished under this provision, Contractor, Subcontractors, and Suppliers may block out (redact) (1) any confidential premium or pricing information and (2) any wording specific to a project or jurisdiction other than those applicable to this Contract.

- E. Owner shall deliver to Contractor, with copies to each additional insured identified in the Contract, certificates of insurance and endorsements establishing that Owner has obtained and is maintaining the policies and coverages required of Owner by the Contract (if any). Upon request by Contractor or any other insured, Owner shall also provide other evidence of such required insurance (if any), including but not limited to copies of policies, documentation of applicable self-insured retentions (if allowed) and deductibles, and full disclosure of all relevant exclusions. In any documentation furnished under this provision, Owner may block out (redact) (1) any confidential premium or pricing information and (2) any wording specific to a project or jurisdiction other than those relevant to this Contract.
- F. Failure of Owner or Contractor to demand such certificates or other evidence of the other party's full compliance with these insurance requirements, or failure of Owner or Contractor to identify a deficiency in compliance from the evidence provided, will not be construed as a waiver of the other party's obligation to obtain and maintain such insurance.
- G. In addition to the liability insurance required to be provided by Contractor, the Owner, at Owner's option, may purchase and maintain Owner's own liability insurance. Owner's liability policies, if any, operate separately and independently from policies required to be provided by Contractor, and Contractor cannot rely upon Owner's liability policies for any of Contractor's obligations to the Owner, Engineer, or third parties.
- H. Contractor shall require:
 - 1. Subcontractors to purchase and maintain worker's compensation, commercial general liability, and other insurance that is appropriate for their participation in the Project, and to name as additional insureds Owner and Engineer (and any other individuals or entities identified in the Supplementary Conditions as additional insureds on Contractor's liability policies) on each Subcontractor's commercial general liability insurance policy; and
 - 2. Suppliers to purchase and maintain insurance that is appropriate for their participation in the Project.
- I. If either party does not purchase or maintain the insurance required of such party by the Contract, such party shall notify the other party in writing of such failure to purchase prior to the start of the Work, or of such failure to maintain prior to any change in the required coverage.
- J. If Contractor has failed to obtain and maintain required insurance, Contractor's entitlement to enter or remain at the Site will end immediately, and Owner may impose an appropriate set-off against payment for any associated costs (including but not limited to the cost of purchasing necessary insurance coverage), and exercise Owner's termination rights under Article 16.
- K. Without prejudice to any other right or remedy, if a party has failed to obtain required insurance, the other party may elect (but is in no way obligated) to obtain equivalent insurance to protect such other party's interests at the expense of the party who was required to provide such coverage, and the Contract Price will be adjusted accordingly.

- L. Owner does not represent that insurance coverage and limits established in this Contract necessarily will be adequate to protect Contractor or Contractor's interests. Contractor is responsible for determining whether such coverage and limits are adequate to protect its interests, and for obtaining and maintaining any additional insurance that Contractor deems necessary.
- M. The insurance and insurance limits required herein will not be deemed as a limitation on Contractor's liability, or that of its Subcontractors or Suppliers, under the indemnities granted to Owner and other individuals and entities in the Contract or otherwise.
- N. All the policies of insurance required to be purchased and maintained under this Contract will contain a provision or endorsement that the coverage afforded will not be canceled, or renewal refused, until at least 10 days prior written notice has been given to the purchasing policyholder. Within three days of receipt of any such written notice, the purchasing policyholder shall provide a copy of the notice to each other insured and Engineer.

6.03 *Contractor's Insurance*

- A. *Required Insurance:* Contractor shall purchase and maintain Worker's Compensation, Commercial General Liability, and other insurance pursuant to the specific requirements of the Supplementary Conditions.
- B. *General Provisions:* The policies of insurance required by this Paragraph 6.03 as supplemented must:
 - 1. include at least the specific coverages required;
 - 2. be written for not less than the limits provided, or those required by Laws or Regulations, whichever is greater;
 - 3. remain in effect at least until the Work is complete (as set forth in Paragraph 15.06.D), and longer if expressly required elsewhere in this Contract, and at all times thereafter when Contractor may be correcting, removing, or replacing defective Work as a warranty or correction obligation, or otherwise, or returning to the Site to conduct other tasks arising from the Contract;
 - 4. apply with respect to the performance of the Work, whether such performance is by Contractor, any Subcontractor or Supplier, or by anyone directly or indirectly employed by any of them to perform any of the Work, or by anyone for whose acts any of them may be liable; and
 - 5. include all necessary endorsements to support the stated requirements.
- C. *Additional Insureds:* The Contractor's commercial general liability, automobile liability, employer's liability, umbrella or excess, pollution liability, and unmanned aerial vehicle liability policies, if required by this Contract, must:
 - 1. include and list as additional insureds Owner and Engineer, and any individuals or entities identified as additional insureds in the Supplementary Conditions;
 - 2. include coverage for the respective officers, directors, members, partners, employees, and consultants of all such additional insureds;
 - 3. afford primary coverage to these additional insureds for all claims covered thereby (including as applicable those arising from both ongoing and completed operations);

4. not seek contribution from insurance maintained by the additional insured; and
5. as to commercial general liability insurance, apply to additional insureds with respect to liability caused in whole or in part by Contractor's acts or omissions, or the acts and omissions of those working on Contractor's behalf, in the performance of Contractor's operations.

6.04 *Builder's Risk and Other Property Insurance*

- A. *Builder's Risk*: Unless otherwise provided in the Supplementary Conditions, Contractor shall purchase and maintain builder's risk insurance upon the Work on a completed value basis, in the amount of the Work's full insurable replacement cost (subject to such deductible amounts as may be provided in the Supplementary Conditions or required by Laws and Regulations). The specific requirements applicable to the builder's risk insurance are set forth in the Supplementary Conditions.
- B. *Property Insurance for Facilities of Owner Where Work Will Occur*: Owner is responsible for obtaining and maintaining property insurance covering each existing structure, building, or facility in which any part of the Work will occur, or to which any part of the Work will attach or be adjoined. Such property insurance will be written on a special perils (all-risk) form, on a replacement cost basis, providing coverage consistent with that required for the builder's risk insurance, and will be maintained until the Work is complete, as set forth in Paragraph 15.06.D.
- C. *Property Insurance for Substantially Complete Facilities*: Promptly after Substantial Completion, and before actual occupancy or use of the substantially completed Work, Owner will obtain property insurance for such substantially completed Work, and maintain such property insurance at least until the Work is complete, as set forth in Paragraph 15.06.D. Such property insurance will be written on a special perils (all-risk) form, on a replacement cost basis, and provide coverage consistent with that required for the builder's risk insurance. The builder's risk insurance may terminate upon written confirmation of Owner's procurement of such property insurance.
- D. *Partial Occupancy or Use by Owner*: If Owner will occupy or use a portion or portions of the Work prior to Substantial Completion of all the Work, as provided in Paragraph 15.04, then Owner (directly, if it is the purchaser of the builder's risk policy, or through Contractor) will provide advance notice of such occupancy or use to the builder's risk insurer, and obtain an endorsement consenting to the continuation of coverage prior to commencing such partial occupancy or use.
- E. *Insurance of Other Property; Additional Insurance*: If the express insurance provisions of the Contract do not require or address the insurance of a property item or interest, then the entity or individual owning such property item will be responsible for insuring it. If Contractor elects to obtain other special insurance to be included in or supplement the builder's risk or property insurance policies provided under this Paragraph 6.04, it may do so at Contractor's expense.

6.05 *Property Losses; Subrogation*

- A. The builder's risk insurance policy purchased and maintained in accordance with Paragraph 6.04 (or an installation floater policy if authorized by the Supplementary Conditions), will contain provisions to the effect that in the event of payment of any loss or damage the insurer will have no rights of recovery against any insureds thereunder, or against

Engineer or its consultants, or their officers, directors, members, partners, employees, agents, consultants, or subcontractors.

1. Owner and Contractor waive all rights against each other and the respective officers, directors, members, partners, employees, agents, consultants, and subcontractors of each and any of them, for all losses and damages caused by, arising out of, or resulting from any of the perils, risks, or causes of loss covered by such policies and any other property insurance applicable to the Work; and, in addition, waive all such rights against Engineer, its consultants, all individuals or entities identified in the Supplementary Conditions as builder's risk or installation floater insureds, and the officers, directors, members, partners, employees, agents, consultants, and subcontractors of each and any of them, under such policies for losses and damages so caused.
 2. None of the above waivers extends to the rights that any party making such waiver may have to the proceeds of insurance held by Owner or Contractor as trustee or fiduciary, or otherwise payable under any policy so issued.
- B. Any property insurance policy maintained by Owner covering any loss, damage, or consequential loss to Owner's existing structures, buildings, or facilities in which any part of the Work will occur, or to which any part of the Work will attach or adjoin; to adjacent structures, buildings, or facilities of Owner; or to part or all of the completed or substantially completed Work, during partial occupancy or use pursuant to Paragraph 15.04, after Substantial Completion pursuant to Paragraph 15.03, or after final payment pursuant to Paragraph 15.06, will contain provisions to the effect that in the event of payment of any loss or damage the insurer will have no rights of recovery against any insureds thereunder, or against Contractor, Subcontractors, or Engineer, or the officers, directors, members, partners, employees, agents, consultants, or subcontractors of each and any of them, and that the insured is allowed to waive the insurer's rights of subrogation in a written contract executed prior to the loss, damage, or consequential loss.
1. Owner waives all rights against Contractor, Subcontractors, and Engineer, and the officers, directors, members, partners, employees, agents, consultants and subcontractors of each and any of them, for all losses and damages caused by, arising out of, or resulting from fire or any of the perils, risks, or causes of loss covered by such policies.
- C. The waivers in this Paragraph 6.05 include the waiver of rights due to business interruption, loss of use, or other consequential loss extending beyond direct physical loss or damage to Owner's property or the Work caused by, arising out of, or resulting from fire or other insured peril, risk, or cause of loss.
- D. Contractor shall be responsible for assuring that each Subcontract contains provisions whereby the Subcontractor waives all rights against Owner, Contractor, all individuals or entities identified in the Supplementary Conditions as insureds, the Engineer and its consultants, and the officers, directors, members, partners, employees, agents, consultants, and subcontractors of each and any of them, for all losses and damages caused by, arising out of, relating to, or resulting from fire or other peril, risk, or cause of loss covered by builder's risk insurance, installation floater, and any other property insurance applicable to the Work.

6.06 *Receipt and Application of Property Insurance Proceeds*

- A. Any insured loss under the builder's risk and other policies of property insurance required by Paragraph 6.04 will be adjusted and settled with the named insured that purchased the policy. Such named insured shall act as fiduciary for the other insureds, and give notice to such other insureds that adjustment and settlement of a claim is in progress. Any other insured may state its position regarding a claim for insured loss in writing within 15 days after notice of such claim.
- B. Proceeds for such insured losses may be made payable by the insurer either jointly to multiple insureds, or to the named insured that purchased the policy in its own right and as fiduciary for other insureds, subject to the requirements of any applicable mortgage clause. A named insured receiving insurance proceeds under the builder's risk and other policies of insurance required by Paragraph 6.04 shall maintain such proceeds in a segregated account, and distribute such proceeds in accordance with such agreement as the parties in interest may reach, or as otherwise required under the dispute resolution provisions of this Contract or applicable Laws and Regulations.
- C. If no other special agreement is reached, Contractor shall repair or replace the damaged Work, using allocated insurance proceeds.

ARTICLE 7—CONTRACTOR'S RESPONSIBILITIES

7.01 *Contractor's Means and Methods of Construction*

- A. Contractor shall be solely responsible for the means, methods, techniques, sequences, and procedures of construction.
- B. If the Contract Documents note, or Contractor determines, that professional engineering or other design services are needed to carry out Contractor's responsibilities for construction means, methods, techniques, sequences, and procedures, or for Site safety, then Contractor shall cause such services to be provided by a properly licensed design professional, at Contractor's expense. Such services are not Owner-delegated professional design services under this Contract, and neither Owner nor Engineer has any responsibility with respect to (1) Contractor's determination of the need for such services, (2) the qualifications or licensing of the design professionals retained or employed by Contractor, (3) the performance of such services, or (4) any errors, omissions, or defects in such services.

7.02 *Supervision and Superintendence*

- A. Contractor shall supervise, inspect, and direct the Work competently and efficiently, devoting such attention thereto and applying such skills and expertise as may be necessary to perform the Work in accordance with the Contract Documents.
- B. At all times during the progress of the Work, Contractor shall assign a competent resident superintendent who will not be replaced without written notice to Owner and Engineer except under extraordinary circumstances.

7.03 *Labor; Working Hours*

- A. Contractor shall provide competent, suitably qualified personnel to survey and lay out the Work and perform construction as required by the Contract Documents. Contractor shall maintain good discipline and order at the Site.

- B. Contractor shall be fully responsible to Owner and Engineer for all acts and omissions of Contractor's employees; of Suppliers and Subcontractors, and their employees; and of any other individuals or entities performing or furnishing any of the Work, just as Contractor is responsible for Contractor's own acts and omissions.
- C. Except as otherwise required for the safety or protection of persons or the Work or property at the Site or adjacent thereto, and except as otherwise stated in the Contract Documents, all Work at the Site will be performed during regular working hours, Monday through Friday. Contractor will not perform Work on a Saturday, Sunday, or any legal holiday. Contractor may perform Work outside regular working hours or on Saturdays, Sundays, or legal holidays only with Owner's written consent, which will not be unreasonably withheld.

7.04 *Services, Materials, and Equipment*

- A. Unless otherwise specified in the Contract Documents, Contractor shall provide and assume full responsibility for all services, materials, equipment, labor, transportation, construction equipment and machinery, tools, appliances, fuel, power, light, heat, telephone, water, sanitary facilities, temporary facilities, and all other facilities and incidentals necessary for the performance, testing, start up, and completion of the Work, whether or not such items are specifically called for in the Contract Documents.
- B. All materials and equipment incorporated into the Work must be new and of good quality, except as otherwise provided in the Contract Documents. All special warranties and guarantees required by the Specifications will expressly run to the benefit of Owner. If required by Engineer, Contractor shall furnish satisfactory evidence (including reports of required tests) as to the source, kind, and quality of materials and equipment.
- C. All materials and equipment must be stored, applied, installed, connected, erected, protected, used, cleaned, and conditioned in accordance with instructions of the applicable Supplier, except as otherwise may be provided in the Contract Documents.

7.05 *"Or Equals"*

- A. *Contractor's Request; Governing Criteria:* Whenever an item of equipment or material is specified or described in the Contract Documents by using the names of one or more proprietary items or specific Suppliers, the Contract Price has been based upon Contractor furnishing such item as specified. The specification or description of such an item is intended to establish the type, function, appearance, and quality required. Unless the specification or description contains or is followed by words reading that no like, equivalent, or "or equal" item is permitted, Contractor may request that Engineer authorize the use of other items of equipment or material, or items from other proposed Suppliers, under the circumstances described below.
 - 1. If Engineer in its sole discretion determines that an item of equipment or material proposed by Contractor is functionally equal to that named and sufficiently similar so that no change in related Work will be required, Engineer will deem it an "or equal" item. For the purposes of this paragraph, a proposed item of equipment or material will be considered functionally equal to an item so named if:
 - a. in the exercise of reasonable judgment Engineer determines that the proposed item:
 - 1) is at least equal in materials of construction, quality, durability, appearance, strength, and design characteristics;

- 2) will reliably perform at least equally well the function and achieve the results imposed by the design concept of the completed Project as a functioning whole;
 - 3) has a proven record of performance and availability of responsive service; and
 - 4) is not objectionable to Owner.
- b. Contractor certifies that, if the proposed item is approved and incorporated into the Work:
- 1) there will be no increase in cost to the Owner or increase in Contract Times; and
 - 2) the item will conform substantially to the detailed requirements of the item named in the Contract Documents.
- B. *Contractor's Expense*: Contractor shall provide all data in support of any proposed "or equal" item at Contractor's expense.
- C. *Engineer's Evaluation and Determination*: Engineer will be allowed a reasonable time to evaluate each "or-equal" request. Engineer may require Contractor to furnish additional data about the proposed "or-equal" item. Engineer will be the sole judge of acceptability. No "or-equal" item will be ordered, furnished, installed, or utilized until Engineer's review is complete and Engineer determines that the proposed item is an "or-equal," which will be evidenced by an approved Shop Drawing or other written communication. Engineer will advise Contractor in writing of any negative determination.
- D. *Effect of Engineer's Determination*: Neither approval nor denial of an "or-equal" request will result in any change in Contract Price. The Engineer's denial of an "or-equal" request will be final and binding, and may not be reversed through an appeal under any provision of the Contract.
- E. *Treatment as a Substitution Request*: If Engineer determines that an item of equipment or material proposed by Contractor does not qualify as an "or-equal" item, Contractor may request that Engineer consider the item a proposed substitute pursuant to Paragraph 7.06.

7.06 Substitutes

- A. *Contractor's Request; Governing Criteria*: Unless the specification or description of an item of equipment or material required to be furnished under the Contract Documents contains or is followed by words reading that no substitution is permitted, Contractor may request that Engineer authorize the use of other items of equipment or material under the circumstances described below. To the extent possible such requests must be made before commencement of related construction at the Site.
1. Contractor shall submit sufficient information as provided below to allow Engineer to determine if the item of material or equipment proposed is functionally equivalent to that named and an acceptable substitute therefor. Engineer will not accept requests for review of proposed substitute items of equipment or material from anyone other than Contractor.
 2. The requirements for review by Engineer will be as set forth in Paragraph 7.06.B, as supplemented by the Specifications, and as Engineer may decide is appropriate under the circumstances.

3. Contractor shall make written application to Engineer for review of a proposed substitute item of equipment or material that Contractor seeks to furnish or use. The application:
 - a. will certify that the proposed substitute item will:
 - 1) perform adequately the functions and achieve the results called for by the general design;
 - 2) be similar in substance to the item specified; and
 - 3) be suited to the same use as the item specified.
 - b. will state:
 - 1) the extent, if any, to which the use of the proposed substitute item will necessitate a change in Contract Times;
 - 2) whether use of the proposed substitute item in the Work will require a change in any of the Contract Documents (or in the provisions of any other direct contract with Owner for other work on the Project) to adapt the design to the proposed substitute item; and
 - 3) whether incorporation or use of the proposed substitute item in connection with the Work is subject to payment of any license fee or royalty.
 - c. will identify:
 - 1) all variations of the proposed substitute item from the item specified; and
 - 2) available engineering, sales, maintenance, repair, and replacement services.
 - d. will contain an itemized estimate of all costs or credits that will result directly or indirectly from use of such substitute item, including but not limited to changes in Contract Price, shared savings, costs of redesign, and claims of other contractors affected by any resulting change.
- B. *Engineer's Evaluation and Determination*: Engineer will be allowed a reasonable time to evaluate each substitute request, and to obtain comments and direction from Owner. Engineer may require Contractor to furnish additional data about the proposed substitute item. Engineer will be the sole judge of acceptability. No substitute will be ordered, furnished, installed, or utilized until Engineer's review is complete and Engineer determines that the proposed item is an acceptable substitute. Engineer's determination will be evidenced by a Field Order or a proposed Change Order accounting for the substitution itself and all related impacts, including changes in Contract Price or Contract Times. Engineer will advise Contractor in writing of any negative determination.
- C. *Special Guarantee*: Owner may require Contractor to furnish at Contractor's expense a special performance guarantee or other surety with respect to any substitute.
- D. *Reimbursement of Engineer's Cost*: Engineer will record Engineer's costs in evaluating a substitute proposed or submitted by Contractor. Whether or not Engineer approves a substitute so proposed or submitted by Contractor, Contractor shall reimburse Owner for the reasonable charges of Engineer for evaluating each such proposed substitute. Contractor shall also reimburse Owner for the reasonable charges of Engineer for making changes in the Contract Documents (or in the provisions of any other direct contract with Owner) resulting from the acceptance of each proposed substitute.

- E. *Contractor's Expense*: Contractor shall provide all data in support of any proposed substitute at Contractor's expense.
- F. *Effect of Engineer's Determination*: If Engineer approves the substitution request, Contractor shall execute the proposed Change Order and proceed with the substitution. The Engineer's denial of a substitution request will be final and binding, and may not be reversed through an appeal under any provision of the Contract. Contractor may challenge the scope of reimbursement costs imposed under Paragraph 7.06.D, by timely submittal of a Change Proposal.

7.07 *Concerning Subcontractors and Suppliers*

- A. Contractor may retain Subcontractors and Suppliers for the performance of parts of the Work. Such Subcontractors and Suppliers must be acceptable to Owner. The Contractor's retention of a Subcontractor or Supplier for the performance of parts of the Work will not relieve Contractor's obligation to Owner to perform and complete the Work in accordance with the Contract Documents.
- B. Contractor shall retain specific Subcontractors and Suppliers for the performance of designated parts of the Work if required by the Contract to do so.
- C. Subsequent to the submittal of Contractor's Bid or final negotiation of the terms of the Contract, Owner may not require Contractor to retain any Subcontractor or Supplier to furnish or perform any of the Work against which Contractor has reasonable objection.
- D. Prior to entry into any binding subcontract or purchase order, Contractor shall submit to Owner the identity of the proposed Subcontractor or Supplier (unless Owner has already deemed such proposed Subcontractor or Supplier acceptable during the bidding process or otherwise). Such proposed Subcontractor or Supplier shall be deemed acceptable to Owner unless Owner raises a substantive, reasonable objection within 5 days.
- E. Owner may require the replacement of any Subcontractor or Supplier. Owner also may require Contractor to retain specific replacements; provided, however, that Owner may not require a replacement to which Contractor has a reasonable objection. If Contractor has submitted the identity of certain Subcontractors or Suppliers for acceptance by Owner, and Owner has accepted it (either in writing or by failing to make written objection thereto), then Owner may subsequently revoke the acceptance of any such Subcontractor or Supplier so identified solely on the basis of substantive, reasonable objection after due investigation. Contractor shall submit an acceptable replacement for the rejected Subcontractor or Supplier.
- F. If Owner requires the replacement of any Subcontractor or Supplier retained by Contractor to perform any part of the Work, then Contractor shall be entitled to an adjustment in Contract Price or Contract Times, with respect to the replacement; and Contractor shall initiate a Change Proposal for such adjustment within 30 days of Owner's requirement of replacement.
- G. No acceptance by Owner of any such Subcontractor or Supplier, whether initially or as a replacement, will constitute a waiver of the right of Owner to the completion of the Work in accordance with the Contract Documents.

- H. On a monthly basis, Contractor shall submit to Engineer a complete list of all Subcontractors and Suppliers having a direct contract with Contractor, and of all other Subcontractors and Suppliers known to Contractor at the time of submittal.
- I. Contractor shall be solely responsible for scheduling and coordinating the work of Subcontractors and Suppliers.
- J. The divisions and sections of the Specifications and the identifications of any Drawings do not control Contractor in dividing the Work among Subcontractors or Suppliers, or in delineating the Work to be performed by any specific trade.
- K. All Work performed for Contractor by a Subcontractor or Supplier must be pursuant to an appropriate contractual agreement that specifically binds the Subcontractor or Supplier to the applicable terms and conditions of the Contract for the benefit of Owner and Engineer.
- L. Owner may furnish to any Subcontractor or Supplier, to the extent practicable, information about amounts paid to Contractor for Work performed for Contractor by the Subcontractor or Supplier.
- M. Contractor shall restrict all Subcontractors and Suppliers from communicating with Engineer or Owner, except through Contractor or in case of an emergency, or as otherwise expressly allowed in this Contract.

7.08 *Patent Fees and Royalties*

- A. Contractor shall pay all license fees and royalties and assume all costs incident to the use in the performance of the Work or the incorporation in the Work of any invention, design, process, product, or device which is the subject of patent rights or copyrights held by others. If an invention, design, process, product, or device is specified in the Contract Documents for use in the performance of the Work and if, to the actual knowledge of Owner or Engineer, its use is subject to patent rights or copyrights calling for the payment of any license fee or royalty to others, the existence of such rights will be disclosed in the Contract Documents.
- B. To the fullest extent permitted by Laws and Regulations, Owner shall indemnify and hold harmless Contractor, and its officers, directors, members, partners, employees, agents, consultants, and subcontractors, from and against all claims, costs, losses, and damages (including but not limited to all fees and charges of engineers, architects, attorneys, and other professionals, and all court or arbitration or other dispute resolution costs) arising out of or relating to any infringement of patent rights or copyrights incident to the use in the performance of the Work or resulting from the incorporation in the Work of any invention, design, process, product, or device specified in the Contract Documents, but not identified as being subject to payment of any license fee or royalty to others required by patent rights or copyrights.
- C. To the fullest extent permitted by Laws and Regulations, Contractor shall indemnify and hold harmless Owner and Engineer, and the officers, directors, members, partners, employees, agents, consultants and subcontractors of each and any of them, from and against all claims, costs, losses, and damages (including but not limited to all fees and charges of engineers, architects, attorneys, and other professionals and all court or arbitration or other dispute resolution costs) arising out of or relating to any infringement of patent rights or copyrights incident to the use in the performance of the Work or resulting from the incorporation in the Work of any invention, design, process, product, or device not specified in the Contract Documents.

7.09 *Permits*

- A. Unless otherwise provided in the Contract Documents, Contractor shall obtain and pay for all construction permits, licenses, and certificates of occupancy. Owner shall assist Contractor, when necessary, in obtaining such permits and licenses. Contractor shall pay all governmental charges and inspection fees necessary for the prosecution of the Work which are applicable at the time of the submission of Contractor's Bid (or when Contractor became bound under a negotiated contract). Owner shall pay all charges of utility owners for connections for providing permanent service to the Work.

7.10 *Taxes*

- A. Contractor shall pay all sales, consumer, use, and other similar taxes required to be paid by Contractor in accordance with the Laws and Regulations of the place of the Project which are applicable during the performance of the Work.

7.11 *Laws and Regulations*

- A. Contractor shall give all notices required by and shall comply with all Laws and Regulations applicable to the performance of the Work. Neither Owner nor Engineer shall be responsible for monitoring Contractor's compliance with any Laws or Regulations.
- B. If Contractor performs any Work or takes any other action knowing or having reason to know that it is contrary to Laws or Regulations, Contractor shall bear all resulting costs and losses, and shall indemnify and hold harmless Owner and Engineer, and the officers, directors, members, partners, employees, agents, consultants, and subcontractors of each and any of them, from and against all claims, costs, losses, and damages (including but not limited to all fees and charges of engineers, architects, attorneys, and other professionals and all court or arbitration or other dispute resolution costs) arising out of or relating to such Work or other action. It is not Contractor's responsibility to make certain that the Work described in the Contract Documents is in accordance with Laws and Regulations, but this does not relieve Contractor of its obligations under Paragraph 3.03.
- C. Owner or Contractor may give written notice to the other party of any changes after the submission of Contractor's Bid (or after the date when Contractor became bound under a negotiated contract) in Laws or Regulations having an effect on the cost or time of performance of the Work, including but not limited to changes in Laws or Regulations having an effect on procuring permits and on sales, use, value-added, consumption, and other similar taxes. If Owner and Contractor are unable to agree on entitlement to or on the amount or extent, if any, of any adjustment in Contract Price or Contract Times resulting from such changes, then within 30 days of such written notice Contractor may submit a Change Proposal, or Owner may initiate a Claim.

7.12 *Record Documents*

- A. Contractor shall maintain in a safe place at the Site one printed record copy of all Drawings, Specifications, Addenda, Change Orders, Work Change Directives, Field Orders, written interpretations and clarifications, and approved Shop Drawings. Contractor shall keep such record documents in good order and annotate them to show changes made during construction. These record documents, together with all approved Samples, will be available to Engineer for reference. Upon completion of the Work, Contractor shall deliver these record documents to Engineer.

7.13 *Safety and Protection*

- A. Contractor shall be solely responsible for initiating, maintaining, and supervising all safety precautions and programs in connection with the Work. Such responsibility does not relieve Subcontractors of their responsibility for the safety of persons or property in the performance of their work, nor for compliance with applicable safety Laws and Regulations.
- B. Contractor shall designate a qualified and experienced safety representative whose duties and responsibilities are the prevention of Work-related accidents and the maintenance and supervision of safety precautions and programs.
- C. Contractor shall take all necessary precautions for the safety of, and shall provide the necessary protection to prevent damage, injury, or loss to:
 - 1. all persons on the Site or who may be affected by the Work;
 - 2. all the Work and materials and equipment to be incorporated therein, whether in storage on or off the Site; and
 - 3. other property at the Site or adjacent thereto, including trees, shrubs, lawns, walks, pavements, roadways, structures, other work in progress, utilities, and Underground Facilities not designated for removal, relocation, or replacement in the course of construction.
- D. All damage, injury, or loss to any property referred to in Paragraph 7.13.C.2 or 7.13.C.3 caused, directly or indirectly, in whole or in part, by Contractor, any Subcontractor, Supplier, or any other individual or entity directly or indirectly employed by any of them to perform any of the Work, or anyone for whose acts any of them may be liable, shall be remedied by Contractor at its expense (except damage or loss attributable to the fault of Drawings or Specifications or to the acts or omissions of Owner or Engineer or anyone employed by any of them, or anyone for whose acts any of them may be liable, and not attributable, directly or indirectly, in whole or in part, to the fault or negligence of Contractor or any Subcontractor, Supplier, or other individual or entity directly or indirectly employed by any of them).
- E. Contractor shall comply with all applicable Laws and Regulations relating to the safety of persons or property, or to the protection of persons or property from damage, injury, or loss; and shall erect and maintain all necessary safeguards for such safety and protection.
- F. Contractor shall notify Owner; the owners of adjacent property; the owners of Underground Facilities and other utilities (if the identity of such owners is known to Contractor); and other contractors and utility owners performing work at or adjacent to the Site, in writing, when Contractor knows that prosecution of the Work may affect them, and shall cooperate with them in the protection, removal, relocation, and replacement of their property or work in progress.
- G. Contractor shall comply with the applicable requirements of Owner's safety programs, if any. Any Owner's safety programs that are applicable to the Work are identified or included in the Supplementary Conditions or Specifications.
- H. Contractor shall inform Owner and Engineer of the specific requirements of Contractor's safety program with which Owner's and Engineer's employees and representatives must comply while at the Site.

- I. Contractor's duties and responsibilities for safety and protection will continue until all the Work is completed, Engineer has issued a written notice to Owner and Contractor in accordance with Paragraph 15.06.C that the Work is acceptable, and Contractor has left the Site (except as otherwise expressly provided in connection with Substantial Completion).
- J. Contractor's duties and responsibilities for safety and protection will resume whenever Contractor or any Subcontractor or Supplier returns to the Site to fulfill warranty or correction obligations, or to conduct other tasks arising from the Contract Documents.

7.14 *Hazard Communication Programs*

- A. Contractor shall be responsible for coordinating any exchange of safety data sheets (formerly known as material safety data sheets) or other hazard communication information required to be made available to or exchanged between or among employers at the Site in accordance with Laws or Regulations.

7.15 *Emergencies*

- A. In emergencies affecting the safety or protection of persons or the Work or property at the Site or adjacent thereto, Contractor is obligated to act to prevent damage, injury, or loss. Contractor shall give Engineer prompt written notice if Contractor believes that any significant changes in the Work or variations from the Contract Documents have been caused by an emergency, or are required as a result of Contractor's response to an emergency. If Engineer determines that a change in the Contract Documents is required because of an emergency or Contractor's response, a Work Change Directive or Change Order will be issued.

7.16 *Submittals*

A. *Shop Drawing and Sample Requirements*

- 1. Before submitting a Shop Drawing or Sample, Contractor shall:
 - a. review and coordinate the Shop Drawing or Sample with other Shop Drawings and Samples and with the requirements of the Work and the Contract Documents;
 - b. determine and verify:
 - 1) all field measurements, quantities, dimensions, specified performance and design criteria, installation requirements, materials, catalog numbers, and similar information with respect to the Submittal;
 - 2) the suitability of all materials and equipment offered with respect to the indicated application, fabrication, shipping, handling, storage, assembly, and installation pertaining to the performance of the Work; and
 - 3) all information relative to Contractor's responsibilities for means, methods, techniques, sequences, and procedures of construction, and safety precautions and programs incident thereto;
 - c. confirm that the Submittal is complete with respect to all related data included in the Submittal.
- 2. Each Shop Drawing or Sample must bear a stamp or specific written certification that Contractor has satisfied Contractor's obligations under the Contract Documents with respect to Contractor's review of that Submittal, and that Contractor approves the Submittal.

3. With each Shop Drawing or Sample, Contractor shall give Engineer specific written notice of any variations that the Submittal may have from the requirements of the Contract Documents. This notice must be set forth in a written communication separate from the Submittal; and, in addition, in the case of a Shop Drawing by a specific notation made on the Shop Drawing itself.
- B. *Submittal Procedures for Shop Drawings and Samples:* Contractor shall label and submit Shop Drawings and Samples to Engineer for review and approval in accordance with the accepted Schedule of Submittals.
1. *Shop Drawings*
 - a. Contractor shall submit the number of copies required in the Specifications.
 - b. Data shown on the Shop Drawings must be complete with respect to quantities, dimensions, specified performance and design criteria, materials, and similar data to show Engineer the services, materials, and equipment Contractor proposes to provide, and to enable Engineer to review the information for the limited purposes required by Paragraph 7.16.C.
 2. *Samples*
 - a. Contractor shall submit the number of Samples required in the Specifications.
 - b. Contractor shall clearly identify each Sample as to material, Supplier, pertinent data such as catalog numbers, the use for which intended and other data as Engineer may require to enable Engineer to review the Submittal for the limited purposes required by Paragraph 7.16.C.
 3. Where a Shop Drawing or Sample is required by the Contract Documents or the Schedule of Submittals, any related Work performed prior to Engineer's review and approval of the pertinent submittal will be at the sole expense and responsibility of Contractor.
- C. *Engineer's Review of Shop Drawings and Samples*
1. Engineer will provide timely review of Shop Drawings and Samples in accordance with the accepted Schedule of Submittals. Engineer's review and approval will be only to determine if the items covered by the Submittals will, after installation or incorporation in the Work, comply with the requirements of the Contract Documents, and be compatible with the design concept of the completed Project as a functioning whole as indicated by the Contract Documents.
 2. Engineer's review and approval will not extend to means, methods, techniques, sequences, or procedures of construction, or to safety precautions or programs incident thereto.
 3. Engineer's review and approval of a separate item as such will not indicate approval of the assembly in which the item functions.
 4. Engineer's review and approval of a Shop Drawing or Sample will not relieve Contractor from responsibility for any variation from the requirements of the Contract Documents unless Contractor has complied with the requirements of Paragraph 7.16.A.3 and Engineer has given written approval of each such variation by specific written notation thereof incorporated in or accompanying the Shop Drawing or Sample. Engineer will

document any such approved variation from the requirements of the Contract Documents in a Field Order or other appropriate Contract modification.

5. Engineer's review and approval of a Shop Drawing or Sample will not relieve Contractor from responsibility for complying with the requirements of Paragraphs 7.16.A and B.
6. Engineer's review and approval of a Shop Drawing or Sample, or of a variation from the requirements of the Contract Documents, will not, under any circumstances, change the Contract Times or Contract Price, unless such changes are included in a Change Order.
7. Neither Engineer's receipt, review, acceptance, or approval of a Shop Drawing or Sample will result in such item becoming a Contract Document.
8. Contractor shall perform the Work in compliance with the requirements and commitments set forth in approved Shop Drawings and Samples, subject to the provisions of Paragraph 7.16.C.4.

D. Resubmittal Procedures for Shop Drawings and Samples

1. Contractor shall make corrections required by Engineer and shall return the required number of corrected copies of Shop Drawings and submit, as required, new Samples for review and approval. Contractor shall direct specific attention in writing to revisions other than the corrections called for by Engineer on previous Submittals.
2. Contractor shall furnish required Shop Drawing and Sample submittals with sufficient information and accuracy to obtain required approval of an item with no more than two resubmittals. Engineer will record Engineer's time for reviewing a third or subsequent resubmittal of a Shop Drawing or Sample, and Contractor shall be responsible for Engineer's charges to Owner for such time. Owner may impose a set-off against payments due Contractor to secure reimbursement for such charges.
3. If Contractor requests a change of a previously approved Shop Drawing or Sample, Contractor shall be responsible for Engineer's charges to Owner for its review time, and Owner may impose a set-off against payments due Contractor to secure reimbursement for such charges, unless the need for such change is beyond the control of Contractor.

E. Submittals Other than Shop Drawings, Samples, and Owner-Delegated Designs

1. The following provisions apply to all Submittals other than Shop Drawings, Samples, and Owner-delegated designs:
 - a. Contractor shall submit all such Submittals to the Engineer in accordance with the Schedule of Submittals and pursuant to the applicable terms of the Contract Documents.
 - b. Engineer will provide timely review of all such Submittals in accordance with the Schedule of Submittals and return such Submittals with a notation of either Accepted or Not Accepted. Any such Submittal that is not returned within the time established in the Schedule of Submittals will be deemed accepted.
 - c. Engineer's review will be only to determine if the Submittal is acceptable under the requirements of the Contract Documents as to general form and content of the Submittal.

- d. If any such Submittal is not accepted, Contractor shall confer with Engineer regarding the reason for the non-acceptance, and resubmit an acceptable document.
 2. Procedures for the submittal and acceptance of the Progress Schedule, the Schedule of Submittals, and the Schedule of Values are set forth in Paragraphs 2.03, 2.04, and 2.05.
- F. Owner-delegated Designs: Submittals pursuant to Owner-delegated designs are governed by the provisions of Paragraph 7.19.

7.17 Contractor's General Warranty and Guarantee

- A. Contractor warrants and guarantees to Owner that all Work will be in accordance with the Contract Documents and will not be defective. Engineer is entitled to rely on Contractor's warranty and guarantee.
- B. Owner's rights under this warranty and guarantee are in addition to, and are not limited by, Owner's rights under the correction period provisions of Paragraph 15.08. The time in which Owner may enforce its warranty and guarantee rights under this Paragraph 7.17 is limited only by applicable Laws and Regulations restricting actions to enforce such rights; provided, however, that after the end of the correction period under Paragraph 15.08:
1. Owner shall give Contractor written notice of any defective Work within 60 days of the discovery that such Work is defective; and
 2. Such notice will be deemed the start of an event giving rise to a Claim under Paragraph 12.01.B, such that any related Claim must be brought within 30 days of the notice.
- C. Contractor's warranty and guarantee hereunder excludes defects or damage caused by:
1. abuse, or improper modification, maintenance, or operation, by persons other than Contractor, Subcontractors, Suppliers, or any other individual or entity for whom Contractor is responsible; or
 2. normal wear and tear under normal usage.
- D. Contractor's obligation to perform and complete the Work in accordance with the Contract Documents is absolute. None of the following will constitute an acceptance of Work that is not in accordance with the Contract Documents, a release of Contractor's obligation to perform the Work in accordance with the Contract Documents, or a release of Owner's warranty and guarantee rights under this Paragraph 7.17:
1. Observations by Engineer;
 2. Recommendation by Engineer or payment by Owner of any progress or final payment;
 3. The issuance of a certificate of Substantial Completion by Engineer or any payment related thereto by Owner;
 4. Use or occupancy of the Work or any part thereof by Owner;
 5. Any review and approval of a Shop Drawing or Sample submittal;
 6. The issuance of a notice of acceptability by Engineer;
 7. The end of the correction period established in Paragraph 15.08;
 8. Any inspection, test, or approval by others; or

9. Any correction of defective Work by Owner.
- E. If the Contract requires the Contractor to accept the assignment of a contract entered into by Owner, then the specific warranties, guarantees, and correction obligations contained in the assigned contract will govern with respect to Contractor's performance obligations to Owner for the Work described in the assigned contract.

7.18 *Indemnification*

- A. To the fullest extent permitted by Laws and Regulations, and in addition to any other obligations of Contractor under the Contract or otherwise, Contractor shall indemnify and hold harmless Owner and Engineer, and the officers, directors, members, partners, employees, agents, consultants and subcontractors of each and any of them, from losses, damages, costs, and judgments (including but not limited to all fees and charges of engineers, architects, attorneys, and other professionals, and all court or arbitration or other dispute resolution costs) arising from third-party claims or actions relating to or resulting from the performance or furnishing of the Work, provided that any such claim, action, loss, cost, judgment or damage is attributable to bodily injury, sickness, disease, or death, or to damage to or destruction of tangible property (other than the Work itself), including the loss of use resulting therefrom, but only to the extent caused by any negligent act or omission of Contractor, any Subcontractor, any Supplier, or any individual or entity directly or indirectly employed by any of them to perform any of the Work, or anyone for whose acts any of them may be liable.
- B. In any and all claims against Owner or Engineer, or any of their officers, directors, members, partners, employees, agents, consultants, or subcontractors, by any employee (or the survivor or personal representative of such employee) of Contractor, any Subcontractor, any Supplier, or any individual or entity directly or indirectly employed by any of them to perform any of the Work, or anyone for whose acts any of them may be liable, the indemnification obligation under Paragraph 7.18.A will not be limited in any way by any limitation on the amount or type of damages, compensation, or benefits payable by or for Contractor or any such Subcontractor, Supplier, or other individual or entity under workers' compensation acts, disability benefit acts, or other employee benefit acts.

7.19 *Delegation of Professional Design Services*

- A. Owner may require Contractor to provide professional design services for a portion of the Work by express delegation in the Contract Documents. Such delegation will specify the performance and design criteria that such services must satisfy, and the Submittals that Contractor must furnish to Engineer with respect to the Owner-delegated design.
- B. Contractor shall cause such Owner-delegated professional design services to be provided pursuant to the professional standard of care by a properly licensed design professional, whose signature and seal must appear on all drawings, calculations, specifications, certifications, and Submittals prepared by such design professional. Such design professional must issue all certifications of design required by Laws and Regulations.
- C. If a Shop Drawing or other Submittal related to the Owner-delegated design is prepared by Contractor, a Subcontractor, or others for submittal to Engineer, then such Shop Drawing or other Submittal must bear the written approval of Contractor's design professional when submitted by Contractor to Engineer.

- D. Owner and Engineer shall be entitled to rely upon the adequacy, accuracy, and completeness of the services, certifications, and approvals performed or provided by the design professionals retained or employed by Contractor under an Owner-delegated design, subject to the professional standard of care and the performance and design criteria stated in the Contract Documents.
- E. Pursuant to this Paragraph 7.19, Engineer's review, approval, and other determinations regarding design drawings, calculations, specifications, certifications, and other Submittals furnished by Contractor pursuant to an Owner-delegated design will be only for the following limited purposes:
 - 1. Checking for conformance with the requirements of this Paragraph 7.19;
 - 2. Confirming that Contractor (through its design professionals) has used the performance and design criteria specified in the Contract Documents; and
 - 3. Establishing that the design furnished by Contractor is consistent with the design concept expressed in the Contract Documents.
- F. Contractor shall not be responsible for the adequacy of performance or design criteria specified by Owner or Engineer.
- G. Contractor is not required to provide professional services in violation of applicable Laws and Regulations.

ARTICLE 8—OTHER WORK AT THE SITE

8.01 *Other Work*

- A. In addition to and apart from the Work under the Contract Documents, the Owner may perform other work at or adjacent to the Site. Such other work may be performed by Owner's employees, or through contracts between the Owner and third parties. Owner may also arrange to have third-party utility owners perform work on their utilities and facilities at or adjacent to the Site.
- B. If Owner performs other work at or adjacent to the Site with Owner's employees, or through contracts for such other work, then Owner shall give Contractor written notice thereof prior to starting any such other work. If Owner has advance information regarding the start of any third-party utility work that Owner has arranged to take place at or adjacent to the Site, Owner shall provide such information to Contractor.
- C. Contractor shall afford proper and safe access to the Site to each contractor that performs such other work, each utility owner performing other work, and Owner, if Owner is performing other work with Owner's employees, and provide a reasonable opportunity for the introduction and storage of materials and equipment and the execution of such other work.
- D. Contractor shall do all cutting, fitting, and patching of the Work that may be required to properly connect or otherwise make its several parts come together and properly integrate with such other work. Contractor shall not endanger any work of others by cutting, excavating, or otherwise altering such work; provided, however, that Contractor may cut or alter others' work with the written consent of Engineer and the others whose work will be affected.

- E. If the proper execution or results of any part of Contractor's Work depends upon work performed by others, Contractor shall inspect such other work and promptly report to Engineer in writing any delays, defects, or deficiencies in such other work that render it unavailable or unsuitable for the proper execution and results of Contractor's Work. Contractor's failure to so report will constitute an acceptance of such other work as fit and proper for integration with Contractor's Work except for latent defects and deficiencies in such other work.
- F. The provisions of this article are not applicable to work that is performed by third-party utilities or other third-party entities without a contract with Owner, or that is performed without having been arranged by Owner. If such work occurs, then any related delay, disruption, or interference incurred by Contractor is governed by the provisions of Paragraph 4.05.C.3.

8.02 *Coordination*

- A. If Owner intends to contract with others for the performance of other work at or adjacent to the Site, to perform other work at or adjacent to the Site with Owner's employees, or to arrange to have utility owners perform work at or adjacent to the Site, the following will be set forth in the Supplementary Conditions or provided to Contractor prior to the start of any such other work:
 - 1. The identity of the individual or entity that will have authority and responsibility for coordination of the activities among the various contractors;
 - 2. An itemization of the specific matters to be covered by such authority and responsibility; and
 - 3. The extent of such authority and responsibilities.
- B. Unless otherwise provided in the Supplementary Conditions, Owner shall have sole authority and responsibility for such coordination.

8.03 *Legal Relationships*

- A. If, in the course of performing other work for Owner at or adjacent to the Site, the Owner's employees, any other contractor working for Owner, or any utility owner that Owner has arranged to perform work, causes damage to the Work or to the property of Contractor or its Subcontractors, or delays, disrupts, interferes with, or increases the scope or cost of the performance of the Work, through actions or inaction, then Contractor shall be entitled to an equitable adjustment in the Contract Price or the Contract Times. Contractor must submit any Change Proposal seeking an equitable adjustment in the Contract Price or the Contract Times under this paragraph within 30 days of the damaging, delaying, disrupting, or interfering event. The entitlement to, and extent of, any such equitable adjustment will take into account information (if any) regarding such other work that was provided to Contractor in the Contract Documents prior to the submittal of the Bid or the final negotiation of the terms of the Contract, and any remedies available to Contractor under Laws or Regulations concerning utility action or inaction. When applicable, any such equitable adjustment in Contract Price will be conditioned on Contractor assigning to Owner all Contractor's rights against such other contractor or utility owner with respect to the damage, delay, disruption, or interference that is the subject of the adjustment. Contractor's entitlement to an adjustment of the Contract Times or Contract Price is subject to the provisions of Paragraphs 4.05.D and 4.05.E.

- B. Contractor shall take reasonable and customary measures to avoid damaging, delaying, disrupting, or interfering with the work of Owner, any other contractor, or any utility owner performing other work at or adjacent to the Site.
 - 1. If Contractor fails to take such measures and as a result damages, delays, disrupts, or interferes with the work of any such other contractor or utility owner, then Owner may impose a set-off against payments due Contractor, and assign to such other contractor or utility owner the Owner's contractual rights against Contractor with respect to the breach of the obligations set forth in this Paragraph 8.03.B.
 - 2. When Owner is performing other work at or adjacent to the Site with Owner's employees, Contractor shall be liable to Owner for damage to such other work, and for the reasonable direct delay, disruption, and interference costs incurred by Owner as a result of Contractor's failure to take reasonable and customary measures with respect to Owner's other work. In response to such damage, delay, disruption, or interference, Owner may impose a set-off against payments due Contractor.
- C. If Contractor damages, delays, disrupts, or interferes with the work of any other contractor, or any utility owner performing other work at or adjacent to the Site, through Contractor's failure to take reasonable and customary measures to avoid such impacts, or if any claim arising out of Contractor's actions, inactions, or negligence in performance of the Work at or adjacent to the Site is made by any such other contractor or utility owner against Contractor, Owner, or Engineer, then Contractor shall (1) promptly attempt to settle the claim as to all parties through negotiations with such other contractor or utility owner, or otherwise resolve the claim by arbitration or other dispute resolution proceeding or at law, and (2) indemnify and hold harmless Owner and Engineer, and the officers, directors, members, partners, employees, agents, consultants and subcontractors of each and any of them from and against any such claims, and against all costs, losses, and damages (including but not limited to all fees and charges of engineers, architects, attorneys, and other professionals and all court or arbitration or other dispute resolution costs) arising out of or relating to such damage, delay, disruption, or interference.

ARTICLE 9—OWNER'S RESPONSIBILITIES

9.01 *Communications to Contractor*

- A. Except as otherwise provided in these General Conditions, Owner shall issue all communications to Contractor through Engineer.

9.02 *Replacement of Engineer*

- A. Owner may at its discretion appoint an engineer to replace Engineer, provided Contractor makes no reasonable objection to the replacement engineer. The replacement engineer's status under the Contract Documents will be that of the former Engineer.

9.03 *Furnish Data*

- A. Owner shall promptly furnish the data required of Owner under the Contract Documents.

9.04 *Pay When Due*

- A. Owner shall make payments to Contractor when they are due as provided in the Agreement.

- 9.05 *Lands and Easements; Reports, Tests, and Drawings*
- A. Owner's duties with respect to providing lands and easements are set forth in Paragraph 5.01.
 - B. Owner's duties with respect to providing engineering surveys to establish reference points are set forth in Paragraph 4.03.
 - C. Article 5 refers to Owner's identifying and making available to Contractor copies of reports of explorations and tests of conditions at the Site, and drawings of physical conditions relating to existing surface or subsurface structures at the Site.
- 9.06 *Insurance*
- A. Owner's responsibilities, if any, with respect to purchasing and maintaining liability and property insurance are set forth in Article 6.
- 9.07 *Change Orders*
- A. Owner's responsibilities with respect to Change Orders are set forth in Article 11.
- 9.08 *Inspections, Tests, and Approvals*
- A. Owner's responsibility with respect to certain inspections, tests, and approvals is set forth in Paragraph 14.02.B.
- 9.09 *Limitations on Owner's Responsibilities*
- A. The Owner shall not supervise, direct, or have control or authority over, nor be responsible for, Contractor's means, methods, techniques, sequences, or procedures of construction, or the safety precautions and programs incident thereto, or for any failure of Contractor to comply with Laws and Regulations applicable to the performance of the Work. Owner will not be responsible for Contractor's failure to perform the Work in accordance with the Contract Documents.
- 9.10 *Undisclosed Hazardous Environmental Condition*
- A. Owner's responsibility in respect to an undisclosed Hazardous Environmental Condition is set forth in Paragraph 5.06.
- 9.11 *Evidence of Financial Arrangements*
- A. Upon request of Contractor, Owner shall furnish Contractor reasonable evidence that financial arrangements have been made to satisfy Owner's obligations under the Contract (including obligations under proposed changes in the Work).
- 9.12 *Safety Programs*
- A. While at the Site, Owner's employees and representatives shall comply with the specific applicable requirements of Contractor's safety programs of which Owner has been informed.
 - B. Owner shall furnish copies of any applicable Owner safety programs to Contractor.

ARTICLE 10—ENGINEER'S STATUS DURING CONSTRUCTION

10.01 *Owner's Representative*

- A. Engineer will be Owner's representative during the construction period. The duties and responsibilities and the limitations of authority of Engineer as Owner's representative during construction are set forth in the Contract.

10.02 *Visits to Site*

- A. Engineer will make visits to the Site at intervals appropriate to the various stages of construction as Engineer deems necessary in order to observe, as an experienced and qualified design professional, the progress that has been made and the quality of the various aspects of Contractor's executed Work. Based on information obtained during such visits and observations, Engineer, for the benefit of Owner, will determine, in general, if the Work is proceeding in accordance with the Contract Documents. Engineer will not be required to make exhaustive or continuous inspections on the Site to check the quality or quantity of the Work. Engineer's efforts will be directed toward providing for Owner a greater degree of confidence that the completed Work will conform generally to the Contract Documents. On the basis of such visits and observations, Engineer will keep Owner informed of the progress of the Work and will endeavor to guard Owner against defective Work.
- B. Engineer's visits and observations are subject to all the limitations on Engineer's authority and responsibility set forth in Paragraph 10.07. Particularly, but without limitation, during or as a result of Engineer's visits or observations of Contractor's Work, Engineer will not supervise, direct, control, or have authority over or be responsible for Contractor's means, methods, techniques, sequences, or procedures of construction, or the safety precautions and programs incident thereto, or for any failure of Contractor to comply with Laws and Regulations applicable to the performance of the Work.

10.03 *Resident Project Representative*

- A. If Owner and Engineer have agreed that Engineer will furnish a Resident Project Representative to represent Engineer at the Site and assist Engineer in observing the progress and quality of the Work, then the authority and responsibilities of any such Resident Project Representative will be as provided in the Supplementary Conditions, and limitations on the responsibilities thereof will be as provided in the Supplementary Conditions and in Paragraph 10.07.
- B. If Owner designates an individual or entity who is not Engineer's consultant, agent, or employee to represent Owner at the Site, then the responsibilities and authority of such individual or entity will be as provided in the Supplementary Conditions.

10.04 *Engineer's Authority*

- A. Engineer has the authority to reject Work in accordance with Article 14.
- B. Engineer's authority as to Submittals is set forth in Paragraph 7.16.
- C. Engineer's authority as to design drawings, calculations, specifications, certifications and other Submittals from Contractor in response to Owner's delegation (if any) to Contractor of professional design services, is set forth in Paragraph 7.19.
- D. Engineer's authority as to changes in the Work is set forth in Article 11.

E. Engineer's authority as to Applications for Payment is set forth in Article 15.

10.05 *Determinations for Unit Price Work*

A. Engineer will determine the actual quantities and classifications of Unit Price Work performed by Contractor as set forth in Paragraph 13.03.

10.06 *Decisions on Requirements of Contract Documents and Acceptability of Work*

A. Engineer will render decisions regarding the requirements of the Contract Documents, and judge the acceptability of the Work, pursuant to the specific procedures set forth herein for initial interpretations, Change Proposals, and acceptance of the Work. In rendering such decisions and judgments, Engineer will not show partiality to Owner or Contractor, and will not be liable to Owner, Contractor, or others in connection with any proceedings, interpretations, decisions, or judgments conducted or rendered in good faith.

10.07 *Limitations on Engineer's Authority and Responsibilities*

A. Neither Engineer's authority or responsibility under this Article 10 or under any other provision of the Contract, nor any decision made by Engineer in good faith either to exercise or not exercise such authority or responsibility or the undertaking, exercise, or performance of any authority or responsibility by Engineer, will create, impose, or give rise to any duty in contract, tort, or otherwise owed by Engineer to Contractor, any Subcontractor, any Supplier, any other individual or entity, or to any surety for or employee or agent of any of them.

B. Engineer will not supervise, direct, control, or have authority over or be responsible for Contractor's means, methods, techniques, sequences, or procedures of construction, or the safety precautions and programs incident thereto, or for any failure of Contractor to comply with Laws and Regulations applicable to the performance of the Work. Engineer will not be responsible for Contractor's failure to perform the Work in accordance with the Contract Documents.

C. Engineer will not be responsible for the acts or omissions of Contractor or of any Subcontractor, any Supplier, or of any other individual or entity performing any of the Work.

D. Engineer's review of the final Application for Payment and accompanying documentation, and all maintenance and operating instructions, schedules, guarantees, bonds, certificates of inspection, tests and approvals, and other documentation required to be delivered by Contractor under Paragraph 15.06.A, will only be to determine generally that their content complies with the requirements of, and in the case of certificates of inspections, tests, and approvals, that the results certified indicate compliance with the Contract Documents.

E. The limitations upon authority and responsibility set forth in this Paragraph 10.07 also apply to the Resident Project Representative, if any.

10.08 *Compliance with Safety Program*

A. While at the Site, Engineer's employees and representatives will comply with the specific applicable requirements of Owner's and Contractor's safety programs of which Engineer has been informed.

ARTICLE 11—CHANGES TO THE CONTRACT

11.01 *Amending and Supplementing the Contract*

- A. The Contract may be amended or supplemented by a Change Order, a Work Change Directive, or a Field Order.
- B. If an amendment or supplement to the Contract includes a change in the Contract Price or the Contract Times, such amendment or supplement must be set forth in a Change Order.
- C. All changes to the Contract that involve (1) the performance or acceptability of the Work, (2) the design (as set forth in the Drawings, Specifications, or otherwise), or (3) other engineering or technical matters, must be supported by Engineer's recommendation. Owner and Contractor may amend other terms and conditions of the Contract without the recommendation of the Engineer.

11.02 *Change Orders*

- A. Owner and Contractor shall execute appropriate Change Orders covering:
 - 1. Changes in Contract Price or Contract Times which are agreed to by the parties, including any undisputed sum or amount of time for Work actually performed in accordance with a Work Change Directive;
 - 2. Changes in Contract Price resulting from an Owner set-off, unless Contractor has duly contested such set-off;
 - 3. Changes in the Work which are: (a) ordered by Owner pursuant to Paragraph 11.05, (b) required because of Owner's acceptance of defective Work under Paragraph 14.04 or Owner's correction of defective Work under Paragraph 14.07, or (c) agreed to by the parties, subject to the need for Engineer's recommendation if the change in the Work involves the design (as set forth in the Drawings, Specifications, or otherwise) or other engineering or technical matters; and
 - 4. Changes that embody the substance of any final and binding results under: Paragraph 11.03.B, resolving the impact of a Work Change Directive; Paragraph 11.09, concerning Change Proposals; Article 12, Claims; Paragraph 13.02.D, final adjustments resulting from allowances; Paragraph 13.03.D, final adjustments relating to determination of quantities for Unit Price Work; and similar provisions.
- B. If Owner or Contractor refuses to execute a Change Order that is required to be executed under the terms of Paragraph 11.02.A, it will be deemed to be of full force and effect, as if fully executed.

11.03 *Work Change Directives*

- A. A Work Change Directive will not change the Contract Price or the Contract Times but is evidence that the parties expect that the modification ordered or documented by a Work Change Directive will be incorporated in a subsequently issued Change Order, following negotiations by the parties as to the Work Change Directive's effect, if any, on the Contract Price and Contract Times; or, if negotiations are unsuccessful, by a determination under the terms of the Contract Documents governing adjustments, expressly including Paragraph 11.07 regarding change of Contract Price.

- B. If Owner has issued a Work Change Directive and:
 - 1. Contractor believes that an adjustment in Contract Times or Contract Price is necessary, then Contractor shall submit any Change Proposal seeking such an adjustment no later than 30 days after the completion of the Work set out in the Work Change Directive.
 - 2. Owner believes that an adjustment in Contract Times or Contract Price is necessary, then Owner shall submit any Claim seeking such an adjustment no later than 60 days after issuance of the Work Change Directive.

11.04 *Field Orders*

- A. Engineer may authorize minor changes in the Work if the changes do not involve an adjustment in the Contract Price or the Contract Times and are compatible with the design concept of the completed Project as a functioning whole as indicated by the Contract Documents. Such changes will be accomplished by a Field Order and will be binding on Owner and also on Contractor, which shall perform the Work involved promptly.
- B. If Contractor believes that a Field Order justifies an adjustment in the Contract Price or Contract Times, then before proceeding with the Work at issue, Contractor shall submit a Change Proposal as provided herein.

11.05 *Owner-Authorized Changes in the Work*

- A. Without invalidating the Contract and without notice to any surety, Owner may, at any time or from time to time, order additions, deletions, or revisions in the Work. Changes involving the design (as set forth in the Drawings, Specifications, or otherwise) or other engineering or technical matters will be supported by Engineer's recommendation.
- B. Such changes in the Work may be accomplished by a Change Order, if Owner and Contractor have agreed as to the effect, if any, of the changes on Contract Times or Contract Price; or by a Work Change Directive. Upon receipt of any such document, Contractor shall promptly proceed with the Work involved; or, in the case of a deletion in the Work, promptly cease construction activities with respect to such deleted Work. Added or revised Work must be performed under the applicable conditions of the Contract Documents.
- C. Nothing in this Paragraph 11.05 obligates Contractor to undertake work that Contractor reasonably concludes cannot be performed in a manner consistent with Contractor's safety obligations under the Contract Documents or Laws and Regulations.

11.06 *Unauthorized Changes in the Work*

- A. Contractor shall not be entitled to an increase in the Contract Price or an extension of the Contract Times with respect to any work performed that is not required by the Contract Documents, as amended, modified, or supplemented, except in the case of an emergency as provided in Paragraph 7.15 or in the case of uncovering Work as provided in Paragraph 14.05.C.2.

11.07 *Change of Contract Price*

- A. The Contract Price may only be changed by a Change Order. Any Change Proposal for an adjustment in the Contract Price must comply with the provisions of Paragraph 11.09. Any Claim for an adjustment of Contract Price must comply with the provisions of Article 12.
- B. An adjustment in the Contract Price will be determined as follows:

1. Where the Work involved is covered by unit prices contained in the Contract Documents, then by application of such unit prices to the quantities of the items involved (subject to the provisions of Paragraph 13.03);
 2. Where the Work involved is not covered by unit prices contained in the Contract Documents, then by a mutually agreed lump sum (which may include an allowance for overhead and profit not necessarily in accordance with Paragraph 11.07.C.2); or
 3. Where the Work involved is not covered by unit prices contained in the Contract Documents and the parties do not reach mutual agreement to a lump sum, then on the basis of the Cost of the Work (determined as provided in Paragraph 13.01) plus a Contractor's fee for overhead and profit (determined as provided in Paragraph 11.07.C).
- C. *Contractor's Fee*: When applicable, the Contractor's fee for overhead and profit will be determined as follows:
1. A mutually acceptable fixed fee; or
 2. If a fixed fee is not agreed upon, then a fee based on the following percentages of the various portions of the Cost of the Work:
 - a. For costs incurred under Paragraphs 13.01.B.1 and 13.01.B.2, the Contractor's fee will be 15 percent;
 - b. For costs incurred under Paragraph 13.01.B.3, the Contractor's fee will be 5 percent;
 - c. Where one or more tiers of subcontracts are on the basis of Cost of the Work plus a fee and no fixed fee is agreed upon, the intent of Paragraphs 11.07.C.2.a and 11.07.C.2.b is that the Contractor's fee will be based on: (1) a fee of 15 percent of the costs incurred under Paragraphs 13.01.B.1 and 13.01.B.2 by the Subcontractor that actually performs the Work, at whatever tier, and (2) with respect to Contractor itself and to any Subcontractors of a tier higher than that of the Subcontractor that actually performs the Work, a fee of 5 percent of the amount (fee plus underlying costs incurred) attributable to the next lower tier Subcontractor; provided, however, that for any such subcontracted Work the maximum total fee to be paid by Owner will be no greater than 27 percent of the costs incurred by the Subcontractor that actually performs the Work;
 - d. No fee will be payable on the basis of costs itemized under Paragraphs 13.01.B.4, 13.01.B.5, and 13.01.C;
 - e. The amount of credit to be allowed by Contractor to Owner for any change which results in a net decrease in Cost of the Work will be the amount of the actual net decrease in Cost of the Work and a deduction of an additional amount equal to 5 percent of such actual net decrease in Cost of the Work; and
 - f. When both additions and credits are involved in any one change or Change Proposal, the adjustment in Contractor's fee will be computed by determining the sum of the costs in each of the cost categories in Paragraph 13.01.B (specifically, payroll costs, Paragraph 13.01.B.1; incorporated materials and equipment costs, Paragraph 13.01.B.2; Subcontract costs, Paragraph 13.01.B.3; special consultants costs, Paragraph 13.01.B.4; and other costs, Paragraph 13.01.B.5) and applying to each such cost category sum the appropriate fee from Paragraphs 11.07.C.2.a through 11.07.C.2.e, inclusive.

11.08 *Change of Contract Times*

- A. The Contract Times may only be changed by a Change Order. Any Change Proposal for an adjustment in the Contract Times must comply with the provisions of Paragraph 11.09. Any Claim for an adjustment in the Contract Times must comply with the provisions of Article 12.
- B. Delay, disruption, and interference in the Work, and any related changes in Contract Times, are addressed in and governed by Paragraph 4.05.

11.09 *Change Proposals*

- A. *Purpose and Content:* Contractor shall submit a Change Proposal to Engineer to request an adjustment in the Contract Times or Contract Price; contest an initial decision by Engineer concerning the requirements of the Contract Documents or relating to the acceptability of the Work under the Contract Documents; challenge a set-off against payment due; or seek other relief under the Contract. The Change Proposal will specify any proposed change in Contract Times or Contract Price, or other proposed relief, and explain the reason for the proposed change, with citations to any governing or applicable provisions of the Contract Documents. Each Change Proposal will address only one issue, or a set of closely related issues.

B. *Change Proposal Procedures*

1. *Submittal:* Contractor shall submit each Change Proposal to Engineer within 30 days after the start of the event giving rise thereto, or after such initial decision.
2. *Supporting Data:* The Contractor shall submit supporting data, including the proposed change in Contract Price or Contract Time (if any), to the Engineer and Owner within 15 days after the submittal of the Change Proposal.
 - a. Change Proposals based on or related to delay, interruption, or interference must comply with the provisions of Paragraphs 4.05.D and 4.05.E.
 - b. Change proposals related to a change of Contract Price must include full and detailed accounts of materials incorporated into the Work and labor and equipment used for the subject Work.

The supporting data must be accompanied by a written statement that the supporting data are accurate and complete, and that any requested time or price adjustment is the entire adjustment to which Contractor believes it is entitled as a result of said event.

3. *Engineer's Initial Review:* Engineer will advise Owner regarding the Change Proposal, and consider any comments or response from Owner regarding the Change Proposal. If in its discretion Engineer concludes that additional supporting data is needed before conducting a full review and making a decision regarding the Change Proposal, then Engineer may request that Contractor submit such additional supporting data by a date specified by Engineer, prior to Engineer beginning its full review of the Change Proposal.
4. *Engineer's Full Review and Action on the Change Proposal:* Upon receipt of Contractor's supporting data (including any additional data requested by Engineer), Engineer will conduct a full review of each Change Proposal and, within 30 days after such receipt of the Contractor's supporting data, either approve the Change Proposal in whole, deny it in whole, or approve it in part and deny it in part. Such actions must be in writing, with a copy provided to Owner and Contractor. If Engineer does not take action on the Change

Proposal within 30 days, then either Owner or Contractor may at any time thereafter submit a letter to the other party indicating that as a result of Engineer's inaction the Change Proposal is deemed denied, thereby commencing the time for appeal of the denial under Article 12.

5. *Binding Decision*: Engineer's decision is final and binding upon Owner and Contractor, unless Owner or Contractor appeals the decision by filing a Claim under Article 12.
- C. *Resolution of Certain Change Proposals*: If the Change Proposal does not involve the design (as set forth in the Drawings, Specifications, or otherwise), the acceptability of the Work, or other engineering or technical matters, then Engineer will notify the parties in writing that the Engineer is unable to resolve the Change Proposal. For purposes of further resolution of such a Change Proposal, such notice will be deemed a denial, and Contractor may choose to seek resolution under the terms of Article 12.
- D. *Post-Completion*: Contractor shall not submit any Change Proposals after Engineer issues a written recommendation of final payment pursuant to Paragraph 15.06.B.

11.10 *Notification to Surety*

- A. If the provisions of any bond require notice to be given to a surety of any change affecting the general scope of the Work or the provisions of the Contract Documents (including, but not limited to, Contract Price or Contract Times), the giving of any such notice will be Contractor's responsibility. The amount of each applicable bond will be adjusted to reflect the effect of any such change.

ARTICLE 12—CLAIMS

12.01 *Claims*

- A. *Claims Process*: The following disputes between Owner and Contractor are subject to the Claims process set forth in this article:
 1. Appeals by Owner or Contractor of Engineer's decisions regarding Change Proposals;
 2. Owner demands for adjustments in the Contract Price or Contract Times, or other relief under the Contract Documents;
 3. Disputes that Engineer has been unable to address because they do not involve the design (as set forth in the Drawings, Specifications, or otherwise), the acceptability of the Work, or other engineering or technical matters; and
 4. Subject to the waiver provisions of Paragraph 15.07, any dispute arising after Engineer has issued a written recommendation of final payment pursuant to Paragraph 15.06.B.
- B. *Submittal of Claim*: The party submitting a Claim shall deliver it directly to the other party to the Contract promptly (but in no event later than 30 days) after the start of the event giving rise thereto; in the case of appeals regarding Change Proposals within 30 days of the decision under appeal. The party submitting the Claim shall also furnish a copy to the Engineer, for its information only. The responsibility to substantiate a Claim rests with the party making the Claim. In the case of a Claim by Contractor seeking an increase in the Contract Times or Contract Price, Contractor shall certify that the Claim is made in good faith, that the supporting data are accurate and complete, and that to the best of Contractor's knowledge

and belief the amount of time or money requested accurately reflects the full amount to which Contractor is entitled.

- C. *Review and Resolution*: The party receiving a Claim shall review it thoroughly, giving full consideration to its merits. The two parties shall seek to resolve the Claim through the exchange of information and direct negotiations. The parties may extend the time for resolving the Claim by mutual agreement. All actions taken on a Claim will be stated in writing and submitted to the other party, with a copy to Engineer.
- D. *Mediation*
 - 1. At any time after initiation of a Claim, Owner and Contractor may mutually agree to mediation of the underlying dispute. The agreement to mediate will stay the Claim submittal and response process.
 - 2. If Owner and Contractor agree to mediation, then after 60 days from such agreement, either Owner or Contractor may unilaterally terminate the mediation process, and the Claim submittal and decision process will resume as of the date of the termination. If the mediation proceeds but is unsuccessful in resolving the dispute, the Claim submittal and decision process will resume as of the date of the conclusion of the mediation, as determined by the mediator.
 - 3. Owner and Contractor shall each pay one-half of the mediator's fees and costs.
- E. *Partial Approval*: If the party receiving a Claim approves the Claim in part and denies it in part, such action will be final and binding unless within 30 days of such action the other party invokes the procedure set forth in Article 17 for final resolution of disputes.
- F. *Denial of Claim*: If efforts to resolve a Claim are not successful, the party receiving the Claim may deny it by giving written notice of denial to the other party. If the receiving party does not take action on the Claim within 90 days, then either Owner or Contractor may at any time thereafter submit a letter to the other party indicating that as a result of the inaction, the Claim is deemed denied, thereby commencing the time for appeal of the denial. A denial of the Claim will be final and binding unless within 30 days of the denial the other party invokes the procedure set forth in Article 17 for the final resolution of disputes.
- G. *Final and Binding Results*: If the parties reach a mutual agreement regarding a Claim, whether through approval of the Claim, direct negotiations, mediation, or otherwise; or if a Claim is approved in part and denied in part, or denied in full, and such actions become final and binding; then the results of the agreement or action on the Claim will be incorporated in a Change Order or other written document to the extent they affect the Contract, including the Work, the Contract Times, or the Contract Price.

ARTICLE 13—COST OF THE WORK; ALLOWANCES; UNIT PRICE WORK

13.01 *Cost of the Work*

- A. *Purposes for Determination of Cost of the Work*: The term Cost of the Work means the sum of all costs necessary for the proper performance of the Work at issue, as further defined below. The provisions of this Paragraph 13.01 are used for two distinct purposes:
 - 1. To determine Cost of the Work when Cost of the Work is a component of the Contract Price, under cost-plus-fee, time-and-materials, or other cost-based terms; or

2. When needed to determine the value of a Change Order, Change Proposal, Claim, set-off, or other adjustment in Contract Price. When the value of any such adjustment is determined on the basis of Cost of the Work, Contractor is entitled only to those additional or incremental costs required because of the change in the Work or because of the event giving rise to the adjustment.
- B. *Costs Included:* Except as otherwise may be agreed to in writing by Owner, costs included in the Cost of the Work will be in amounts no higher than those commonly incurred in the locality of the Project, will not include any of the costs itemized in Paragraph 13.01.C, and will include only the following items:
1. Payroll costs for employees in the direct employ of Contractor in the performance of the Work under schedules of job classifications agreed upon by Owner and Contractor in advance of the subject Work. Such employees include, without limitation, superintendents, foremen, safety managers, safety representatives, and other personnel employed full time on the Work. Payroll costs for employees not employed full time on the Work will be apportioned on the basis of their time spent on the Work. Payroll costs include, but are not limited to, salaries and wages plus the cost of fringe benefits, which include social security contributions, unemployment, excise, and payroll taxes, workers' compensation, health and retirement benefits, sick leave, and vacation and holiday pay applicable thereto. The expenses of performing Work outside of regular working hours, on Saturday, Sunday, or legal holidays, will be included in the above to the extent authorized by Owner.
 2. Cost of all materials and equipment furnished and incorporated in the Work, including costs of transportation and storage thereof, and Suppliers' field services required in connection therewith. All cash discounts accrue to Contractor unless Owner deposits funds with Contractor with which to make payments, in which case the cash discounts will accrue to Owner. All trade discounts, rebates, and refunds and returns from sale of surplus materials and equipment will accrue to Owner, and Contractor shall make provisions so that they may be obtained.
 3. Payments made by Contractor to Subcontractors for Work performed by Subcontractors. If required by Owner, Contractor shall obtain competitive bids from subcontractors acceptable to Owner and Contractor and shall deliver such bids to Owner, which will then determine, with the advice of Engineer, which bids, if any, will be acceptable. If any subcontract provides that the Subcontractor is to be paid on the basis of Cost of the Work plus a fee, the Subcontractor's Cost of the Work and fee will be determined in the same manner as Contractor's Cost of the Work and fee as provided in this Paragraph 13.01.
 4. Costs of special consultants (including but not limited to engineers, architects, testing laboratories, surveyors, attorneys, and accountants) employed or retained for services specifically related to the Work.
 5. Other costs consisting of the following:
 - a. The proportion of necessary transportation, travel, and subsistence expenses of Contractor's employees incurred in discharge of duties connected with the Work.
 - b. Cost, including transportation and maintenance, of all materials, supplies, equipment, machinery, appliances, office, and temporary facilities at the Site, which are

consumed in the performance of the Work, and cost, less market value, of such items used but not consumed which remain the property of Contractor.

- 1) In establishing included costs for materials such as scaffolding, plating, or sheeting, consideration will be given to the actual or the estimated life of the material for use on other projects; or rental rates may be established on the basis of purchase or salvage value of such items, whichever is less. Contractor will not be eligible for compensation for such items in an amount that exceeds the purchase cost of such item.

c. *Construction Equipment Rental*

- 1) Rentals of all construction equipment and machinery, and the parts thereof, in accordance with rental agreements approved by Owner as to price (including any surcharge or special rates applicable to overtime use of the construction equipment or machinery), and the costs of transportation, loading, unloading, assembly, dismantling, and removal thereof. All such costs will be in accordance with the terms of said rental agreements. The rental of any such equipment, machinery, or parts must cease when the use thereof is no longer necessary for the Work.
- 2) Costs for equipment and machinery owned by Contractor or a Contractor-related entity will be paid at a rate shown for such equipment in the equipment rental rate book specified in the Supplementary Conditions. An hourly rate will be computed by dividing the monthly rates by 176. These computed rates will include all operating costs.
- 3) With respect to Work that is the result of a Change Order, Change Proposal, Claim, set-off, or other adjustment in Contract Price ("changed Work"), included costs will be based on the time the equipment or machinery is in use on the changed Work and the costs of transportation, loading, unloading, assembly, dismantling, and removal when directly attributable to the changed Work. The cost of any such equipment or machinery, or parts thereof, must cease to accrue when the use thereof is no longer necessary for the changed Work.

- d. Sales, consumer, use, and other similar taxes related to the Work, and for which Contractor is liable, as imposed by Laws and Regulations.
- e. Deposits lost for causes other than negligence of Contractor, any Subcontractor, or anyone directly or indirectly employed by any of them or for whose acts any of them may be liable, and royalty payments and fees for permits and licenses.
- f. Losses and damages (and related expenses) caused by damage to the Work, not compensated by insurance or otherwise, sustained by Contractor in connection with the performance of the Work (except losses and damages within the deductible amounts of builder's risk or other property insurance established in accordance with Paragraph 6.04), provided such losses and damages have resulted from causes other than the negligence of Contractor, any Subcontractor, or anyone directly or indirectly employed by any of them or for whose acts any of them may be liable. Such losses include settlements made with the written consent and approval of Owner. No such losses, damages, and expenses will be included in the Cost of the Work for the purpose of determining Contractor's fee.

- g. The cost of utilities, fuel, and sanitary facilities at the Site.
- h. Minor expenses such as communication service at the Site, express and courier services, and similar petty cash items in connection with the Work.
- i. The costs of premiums for all bonds and insurance that Contractor is required by the Contract Documents to purchase and maintain.

C. *Costs Excluded*: The term Cost of the Work does not include any of the following items:

- 1. Payroll costs and other compensation of Contractor's officers, executives, principals, general managers, engineers, architects, estimators, attorneys, auditors, accountants, purchasing and contracting agents, expeditors, timekeepers, clerks, and other personnel employed by Contractor, whether at the Site or in Contractor's principal or branch office for general administration of the Work and not specifically included in the agreed upon schedule of job classifications referred to in Paragraph 13.01.B.1 or specifically covered by Paragraph 13.01.B.4. The payroll costs and other compensation excluded here are to be considered administrative costs covered by the Contractor's fee.
- 2. The cost of purchasing, renting, or furnishing small tools and hand tools.
- 3. Expenses of Contractor's principal and branch offices other than Contractor's office at the Site.
- 4. Any part of Contractor's capital expenses, including interest on Contractor's capital employed for the Work and charges against Contractor for delinquent payments.
- 5. Costs due to the negligence of Contractor, any Subcontractor, or anyone directly or indirectly employed by any of them or for whose acts any of them may be liable, including but not limited to, the correction of defective Work, disposal of materials or equipment wrongly supplied, and making good any damage to property.
- 6. Expenses incurred in preparing and advancing Claims.
- 7. Other overhead or general expense costs of any kind and the costs of any item not specifically and expressly included in Paragraph 13.01.B.

D. *Contractor's Fee*

- 1. When the Work as a whole is performed on the basis of cost-plus-a-fee, then:
 - a. Contractor's fee for the Work set forth in the Contract Documents as of the Effective Date of the Contract will be determined as set forth in the Agreement.
 - b. for any Work covered by a Change Order, Change Proposal, Claim, set-off, or other adjustment in Contract Price on the basis of Cost of the Work, Contractor's fee will be determined as follows:
 - 1) When the fee for the Work as a whole is a percentage of the Cost of the Work, the fee will automatically adjust as the Cost of the Work changes.
 - 2) When the fee for the Work as a whole is a fixed fee, the fee for any additions or deletions will be determined in accordance with Paragraph 11.07.C.2.
- 2. When the Work as a whole is performed on the basis of a stipulated sum, or any other basis other than cost-plus-a-fee, then Contractor's fee for any Work covered by a Change

Order, Change Proposal, Claim, set-off, or other adjustment in Contract Price on the basis of Cost of the Work will be determined in accordance with Paragraph 11.07.C.2.

- E. *Documentation and Audit:* Whenever the Cost of the Work for any purpose is to be determined pursuant to this Article 13, Contractor and pertinent Subcontractors will establish and maintain records of the costs in accordance with generally accepted accounting practices. Subject to prior written notice, Owner will be afforded reasonable access, during normal business hours, to all Contractor's accounts, records, books, correspondence, instructions, drawings, receipts, vouchers, memoranda, and similar data relating to the Cost of the Work and Contractor's fee. Contractor shall preserve all such documents for a period of three years after the final payment by Owner. Pertinent Subcontractors will afford such access to Owner, and preserve such documents, to the same extent required of Contractor.

13.02 Allowances

- A. It is understood that Contractor has included in the Contract Price all allowances so named in the Contract Documents and shall cause the Work so covered to be performed for such sums and by such persons or entities as may be acceptable to Owner and Engineer.
- B. *Cash Allowances:* Contractor agrees that:
 - 1. the cash allowances include the cost to Contractor (less any applicable trade discounts) of materials and equipment required by the allowances to be delivered at the Site, and all applicable taxes; and
 - 2. Contractor's costs for unloading and handling on the Site, labor, installation, overhead, profit, and other expenses contemplated for the cash allowances have been included in the Contract Price and not in the allowances, and no demand for additional payment for any of the foregoing will be valid.
- C. *Owner's Contingency Allowance:* Contractor agrees that an Owner's contingency allowance, if any, is for the sole use of Owner to cover unanticipated costs.
- D. Prior to final payment, an appropriate Change Order will be issued as recommended by Engineer to reflect actual amounts due Contractor for Work covered by allowances, and the Contract Price will be correspondingly adjusted.

13.03 Unit Price Work

- A. Where the Contract Documents provide that all or part of the Work is to be Unit Price Work, initially the Contract Price will be deemed to include for all Unit Price Work an amount equal to the sum of the unit price for each separately identified item of Unit Price Work times the estimated quantity of each item as indicated in the Agreement.
- B. The estimated quantities of items of Unit Price Work are not guaranteed and are solely for the purpose of comparison of Bids and determining an initial Contract Price. Payments to Contractor for Unit Price Work will be based on actual quantities.
- C. Each unit price will be deemed to include an amount considered by Contractor to be adequate to cover Contractor's overhead and profit for each separately identified item.
- D. Engineer will determine the actual quantities and classifications of Unit Price Work performed by Contractor. Engineer will review with Contractor the Engineer's preliminary determinations on such matters before rendering a written decision thereon (by recommendation of an Application for Payment or otherwise). Engineer's written decision

thereon will be final and binding (except as modified by Engineer to reflect changed factual conditions or more accurate data) upon Owner and Contractor, and the final adjustment of Contract Price will be set forth in a Change Order, subject to the provisions of the following paragraph.

E. *Adjustments in Unit Price*

1. Contractor or Owner shall be entitled to an adjustment in the unit price with respect to an item of Unit Price Work if:
 - a. the quantity of the item of Unit Price Work performed by Contractor differs materially and significantly from the estimated quantity of such item indicated in the Agreement; and
 - b. Contractor's unit costs to perform the item of Unit Price Work have changed materially and significantly as a result of the quantity change.
2. The adjustment in unit price will account for and be coordinated with any related changes in quantities of other items of Work, and in Contractor's costs to perform such other Work, such that the resulting overall change in Contract Price is equitable to Owner and Contractor.
3. Adjusted unit prices will apply to all units of that item.

ARTICLE 14—TESTS AND INSPECTIONS; CORRECTION, REMOVAL, OR ACCEPTANCE OF DEFECTIVE WORK

14.01 *Access to Work*

- A. Owner, Engineer, their consultants and other representatives and personnel of Owner, independent testing laboratories, and authorities having jurisdiction have access to the Site and the Work at reasonable times for their observation, inspection, and testing. Contractor shall provide them proper and safe conditions for such access and advise them of Contractor's safety procedures and programs so that they may comply with such procedures and programs as applicable.

14.02 *Tests, Inspections, and Approvals*

- A. Contractor shall give Engineer timely notice of readiness of the Work (or specific parts thereof) for all required inspections and tests, and shall cooperate with inspection and testing personnel to facilitate required inspections and tests.
- B. Owner shall retain and pay for the services of an independent inspector, testing laboratory, or other qualified individual or entity to perform all inspections and tests expressly required by the Contract Documents to be furnished and paid for by Owner, except that costs incurred in connection with tests or inspections of covered Work will be governed by the provisions of Paragraph 14.05.
- C. If Laws or Regulations of any public body having jurisdiction require any Work (or part thereof) specifically to be inspected, tested, or approved by an employee or other representative of such public body, Contractor shall assume full responsibility for arranging and obtaining such inspections, tests, or approvals, pay all costs in connection therewith, and furnish Engineer the required certificates of inspection or approval.

- D. Contractor shall be responsible for arranging, obtaining, and paying for all inspections and tests required:
1. by the Contract Documents, unless the Contract Documents expressly allocate responsibility for a specific inspection or test to Owner;
 2. to attain Owner's and Engineer's acceptance of materials or equipment to be incorporated in the Work;
 3. by manufacturers of equipment furnished under the Contract Documents;
 4. for testing, adjusting, and balancing of mechanical, electrical, and other equipment to be incorporated into the Work; and
 5. for acceptance of materials, mix designs, or equipment submitted for approval prior to Contractor's purchase thereof for incorporation in the Work.

Such inspections and tests will be performed by independent inspectors, testing laboratories, or other qualified individuals or entities acceptable to Owner and Engineer.

- E. If the Contract Documents require the Work (or part thereof) to be approved by Owner, Engineer, or another designated individual or entity, then Contractor shall assume full responsibility for arranging and obtaining such approvals.
- F. If any Work (or the work of others) that is to be inspected, tested, or approved is covered by Contractor without written concurrence of Engineer, Contractor shall, if requested by Engineer, uncover such Work for observation. Such uncovering will be at Contractor's expense unless Contractor had given Engineer timely notice of Contractor's intention to cover the same and Engineer had not acted with reasonable promptness in response to such notice.

14.03 *Defective Work*

- A. *Contractor's Obligation:* It is Contractor's obligation to assure that the Work is not defective.
- B. *Engineer's Authority:* Engineer has the authority to determine whether Work is defective, and to reject defective Work.
- C. *Notice of Defects:* Prompt written notice of all defective Work of which Owner or Engineer has actual knowledge will be given to Contractor.
- D. *Correction, or Removal and Replacement:* Promptly after receipt of written notice of defective Work, Contractor shall correct all such defective Work, whether or not fabricated, installed, or completed, or, if Engineer has rejected the defective Work, remove it from the Project and replace it with Work that is not defective.
- E. *Preservation of Warranties:* When correcting defective Work, Contractor shall take no action that would void or otherwise impair Owner's special warranty and guarantee, if any, on said Work.
- F. *Costs and Damages:* In addition to its correction, removal, and replacement obligations with respect to defective Work, Contractor shall pay all claims, costs, losses, and damages arising out of or relating to defective Work, including but not limited to the cost of the inspection, testing, correction, removal, replacement, or reconstruction of such defective Work, fines levied against Owner by governmental authorities because the Work is defective, and the costs of repair or replacement of work of others resulting from defective Work. Prior to final payment, if Owner and Contractor are unable to agree as to the measure of such claims, costs,

losses, and damages resulting from defective Work, then Owner may impose a reasonable set-off against payments due under Article 15.

14.04 *Acceptance of Defective Work*

- A. If, instead of requiring correction or removal and replacement of defective Work, Owner prefers to accept it, Owner may do so (subject, if such acceptance occurs prior to final payment, to Engineer's confirmation that such acceptance is in general accord with the design intent and applicable engineering principles, and will not endanger public safety). Contractor shall pay all claims, costs, losses, and damages attributable to Owner's evaluation of and determination to accept such defective Work (such costs to be approved by Engineer as to reasonableness), and for the diminished value of the Work to the extent not otherwise paid by Contractor. If any such acceptance occurs prior to final payment, the necessary revisions in the Contract Documents with respect to the Work will be incorporated in a Change Order. If the parties are unable to agree as to the decrease in the Contract Price, reflecting the diminished value of Work so accepted, then Owner may impose a reasonable set-off against payments due under Article 15. If the acceptance of defective Work occurs after final payment, Contractor shall pay an appropriate amount to Owner.

14.05 *Uncovering Work*

- A. Engineer has the authority to require additional inspection or testing of the Work, whether or not the Work is fabricated, installed, or completed.
- B. If any Work is covered contrary to the written request of Engineer, then Contractor shall, if requested by Engineer, uncover such Work for Engineer's observation, and then replace the covering, all at Contractor's expense.
- C. If Engineer considers it necessary or advisable that covered Work be observed by Engineer or inspected or tested by others, then Contractor, at Engineer's request, shall uncover, expose, or otherwise make available for observation, inspection, or testing as Engineer may require, that portion of the Work in question, and provide all necessary labor, material, and equipment.
 1. If it is found that the uncovered Work is defective, Contractor shall be responsible for all claims, costs, losses, and damages arising out of or relating to such uncovering, exposure, observation, inspection, and testing, and of satisfactory replacement or reconstruction (including but not limited to all costs of repair or replacement of work of others); and pending Contractor's full discharge of this responsibility the Owner shall be entitled to impose a reasonable set-off against payments due under Article 15.
 2. If the uncovered Work is not found to be defective, Contractor shall be allowed an increase in the Contract Price or an extension of the Contract Times, directly attributable to such uncovering, exposure, observation, inspection, testing, replacement, and reconstruction. If the parties are unable to agree as to the amount or extent thereof, then Contractor may submit a Change Proposal within 30 days of the determination that the Work is not defective.

14.06 *Owner May Stop the Work*

- A. If the Work is defective, or Contractor fails to supply sufficient skilled workers or suitable materials or equipment, or fails to perform the Work in such a way that the completed Work will conform to the Contract Documents, then Owner may order Contractor to stop the Work,

or any portion thereof, until the cause for such order has been eliminated; however, this right of Owner to stop the Work will not give rise to any duty on the part of Owner to exercise this right for the benefit of Contractor, any Subcontractor, any Supplier, any other individual or entity, or any surety for, or employee or agent of any of them.

14.07 Owner May Correct Defective Work

- A. If Contractor fails within a reasonable time after written notice from Engineer to correct defective Work, or to remove and replace defective Work as required by Engineer, then Owner may, after 7 days' written notice to Contractor, correct or remedy any such deficiency.
- B. In exercising the rights and remedies under this Paragraph 14.07, Owner shall proceed expeditiously. In connection with such corrective or remedial action, Owner may exclude Contractor from all or part of the Site, take possession of all or part of the Work and suspend Contractor's services related thereto, and incorporate in the Work all materials and equipment stored at the Site or for which Owner has paid Contractor but which are stored elsewhere. Contractor shall allow Owner, Owner's representatives, agents and employees, Owner's other contractors, and Engineer and Engineer's consultants access to the Site to enable Owner to exercise the rights and remedies under this paragraph.
- C. All claims, costs, losses, and damages incurred or sustained by Owner in exercising the rights and remedies under this Paragraph 14.07 will be charged against Contractor as set-offs against payments due under Article 15. Such claims, costs, losses and damages will include but not be limited to all costs of repair, or replacement of work of others destroyed or damaged by correction, removal, or replacement of Contractor's defective Work.
- D. Contractor shall not be allowed an extension of the Contract Times because of any delay in the performance of the Work attributable to the exercise by Owner of Owner's rights and remedies under this Paragraph 14.07.

ARTICLE 15—PAYMENTS TO CONTRACTOR; SET-OFFS; COMPLETION; CORRECTION PERIOD

15.01 Progress Payments

- A. *Basis for Progress Payments:* The Schedule of Values established as provided in Article 2 will serve as the basis for progress payments and will be incorporated into a form of Application for Payment acceptable to Engineer. Progress payments for Unit Price Work will be based on the number of units completed during the pay period, as determined under the provisions of Paragraph 13.03. Progress payments for cost-based Work will be based on Cost of the Work completed by Contractor during the pay period.
- B. *Applications for Payments*
 - 1. At least 20 days before the date established in the Agreement for each progress payment (but not more often than once a month), Contractor shall submit to Engineer for review an Application for Payment filled out and signed by Contractor covering the Work completed as of the date of the Application and accompanied by such supporting documentation as is required by the Contract Documents.
 - 2. If payment is requested on the basis of materials and equipment not incorporated in the Work but delivered and suitably stored at the Site or at another location agreed to in writing, the Application for Payment must also be accompanied by: (a) a bill of sale, invoice, copies of subcontract or purchase order payments, or other documentation

establishing full payment by Contractor for the materials and equipment; (b) at Owner's request, documentation warranting that Owner has received the materials and equipment free and clear of all Liens; and (c) evidence that the materials and equipment are covered by appropriate property insurance, a warehouse bond, or other arrangements to protect Owner's interest therein, all of which must be satisfactory to Owner.

3. Beginning with the second Application for Payment, each Application must include an affidavit of Contractor stating that all previous progress payments received by Contractor have been applied to discharge Contractor's legitimate obligations associated with prior Applications for Payment.
4. The amount of retainage with respect to progress payments will be as stipulated in the Agreement.

C. *Review of Applications*

1. Engineer will, within 10 days after receipt of each Application for Payment, including each resubmittal, either indicate in writing a recommendation of payment and present the Application to Owner, or return the Application to Contractor indicating in writing Engineer's reasons for refusing to recommend payment. In the latter case, Contractor may make the necessary corrections and resubmit the Application.
2. Engineer's recommendation of any payment requested in an Application for Payment will constitute a representation by Engineer to Owner, based on Engineer's observations of the executed Work as an experienced and qualified design professional, and on Engineer's review of the Application for Payment and the accompanying data and schedules, that to the best of Engineer's knowledge, information and belief:
 - a. the Work has progressed to the point indicated;
 - b. the quality of the Work is generally in accordance with the Contract Documents (subject to an evaluation of the Work as a functioning whole prior to or upon Substantial Completion, the results of any subsequent tests called for in the Contract Documents, a final determination of quantities and classifications for Unit Price Work under Paragraph 13.03, and any other qualifications stated in the recommendation); and
 - c. the conditions precedent to Contractor's being entitled to such payment appear to have been fulfilled in so far as it is Engineer's responsibility to observe the Work.
3. By recommending any such payment Engineer will not thereby be deemed to have represented that:
 - a. inspections made to check the quality or the quantity of the Work as it has been performed have been exhaustive, extended to every aspect of the Work in progress, or involved detailed inspections of the Work beyond the responsibilities specifically assigned to Engineer in the Contract; or
 - b. there may not be other matters or issues between the parties that might entitle Contractor to be paid additionally by Owner or entitle Owner to withhold payment to Contractor.

4. Neither Engineer's review of Contractor's Work for the purposes of recommending payments nor Engineer's recommendation of any payment, including final payment, will impose responsibility on Engineer:
 - a. to supervise, direct, or control the Work;
 - b. for the means, methods, techniques, sequences, or procedures of construction, or the safety precautions and programs incident thereto;
 - c. for Contractor's failure to comply with Laws and Regulations applicable to Contractor's performance of the Work;
 - d. to make any examination to ascertain how or for what purposes Contractor has used the money paid by Owner; or
 - e. to determine that title to any of the Work, materials, or equipment has passed to Owner free and clear of any Liens.
5. Engineer may refuse to recommend the whole or any part of any payment if, in Engineer's opinion, it would be incorrect to make the representations to Owner stated in Paragraph 15.01.C.2.
6. Engineer will recommend reductions in payment (set-offs) necessary in Engineer's opinion to protect Owner from loss because:
 - a. the Work is defective, requiring correction or replacement;
 - b. the Contract Price has been reduced by Change Orders;
 - c. Owner has been required to correct defective Work in accordance with Paragraph 14.07, or has accepted defective Work pursuant to Paragraph 14.04;
 - d. Owner has been required to remove or remediate a Hazardous Environmental Condition for which Contractor is responsible; or
 - e. Engineer has actual knowledge of the occurrence of any of the events that would constitute a default by Contractor and therefore justify termination for cause under the Contract Documents.

D. *Payment Becomes Due*

1. Ten days after presentation of the Application for Payment to Owner with Engineer's recommendation, the amount recommended (subject to any Owner set-offs) will become due, and when due will be paid by Owner to Contractor.

E. *Reductions in Payment by Owner*

1. In addition to any reductions in payment (set-offs) recommended by Engineer, Owner is entitled to impose a set-off against payment based on any of the following:
 - a. Claims have been made against Owner based on Contractor's conduct in the performance or furnishing of the Work, or Owner has incurred costs, losses, or damages resulting from Contractor's conduct in the performance or furnishing of the Work, including but not limited to claims, costs, losses, or damages from workplace injuries, adjacent property damage, non-compliance with Laws and Regulations, and patent infringement;

- b. Contractor has failed to take reasonable and customary measures to avoid damage, delay, disruption, and interference with other work at or adjacent to the Site;
 - c. Contractor has failed to provide and maintain required bonds or insurance;
 - d. Owner has been required to remove or remediate a Hazardous Environmental Condition for which Contractor is responsible;
 - e. Owner has incurred extra charges or engineering costs related to submittal reviews, evaluations of proposed substitutes, tests and inspections, or return visits to manufacturing or assembly facilities;
 - f. The Work is defective, requiring correction or replacement;
 - g. Owner has been required to correct defective Work in accordance with Paragraph 14.07, or has accepted defective Work pursuant to Paragraph 14.04;
 - h. The Contract Price has been reduced by Change Orders;
 - i. An event has occurred that would constitute a default by Contractor and therefore justify a termination for cause;
 - j. Liquidated or other damages have accrued as a result of Contractor's failure to achieve Milestones, Substantial Completion, or final completion of the Work;
 - k. Liens have been filed in connection with the Work, except where Contractor has delivered a specific bond satisfactory to Owner to secure the satisfaction and discharge of such Liens; or
 - l. Other items entitle Owner to a set-off against the amount recommended.
2. If Owner imposes any set-off against payment, whether based on its own knowledge or on the written recommendations of Engineer, Owner will give Contractor immediate written notice (with a copy to Engineer) stating the reasons for such action and the specific amount of the reduction, and promptly pay Contractor any amount remaining after deduction of the amount so withheld. Owner shall promptly pay Contractor the amount so withheld, or any adjustment thereto agreed to by Owner and Contractor, if Contractor remedies the reasons for such action. The reduction imposed will be binding on Contractor unless it duly submits a Change Proposal contesting the reduction.
 3. Upon a subsequent determination that Owner's refusal of payment was not justified, the amount wrongfully withheld will be treated as an amount due as determined by Paragraph 15.01.D.1 and subject to interest as provided in the Agreement.

15.02 *Contractor's Warranty of Title*

- A. Contractor warrants and guarantees that title to all Work, materials, and equipment furnished under the Contract will pass to Owner free and clear of (1) all Liens and other title defects, and (2) all patent, licensing, copyright, or royalty obligations, no later than 7 days after the time of payment by Owner.

15.03 *Substantial Completion*

- A. When Contractor considers the entire Work ready for its intended use Contractor shall notify Owner and Engineer in writing that the entire Work is substantially complete and request that Engineer issue a certificate of Substantial Completion. Contractor shall at the same time

submit to Owner and Engineer an initial draft of punch list items to be completed or corrected before final payment.

- B. Promptly after Contractor's notification, Owner, Contractor, and Engineer shall make an inspection of the Work to determine the status of completion. If Engineer does not consider the Work substantially complete, Engineer will notify Contractor in writing giving the reasons therefor.
- C. If Engineer considers the Work substantially complete, Engineer will deliver to Owner a preliminary certificate of Substantial Completion which will fix the date of Substantial Completion. Engineer shall attach to the certificate a punch list of items to be completed or corrected before final payment. Owner shall have 7 days after receipt of the preliminary certificate during which to make written objection to Engineer as to any provisions of the certificate or attached punch list. If, after considering the objections to the provisions of the preliminary certificate, Engineer concludes that the Work is not substantially complete, Engineer will, within 14 days after submission of the preliminary certificate to Owner, notify Contractor in writing that the Work is not substantially complete, stating the reasons therefor. If Owner does not object to the provisions of the certificate, or if despite consideration of Owner's objections Engineer concludes that the Work is substantially complete, then Engineer will, within said 14 days, execute and deliver to Owner and Contractor a final certificate of Substantial Completion (with a revised punch list of items to be completed or corrected) reflecting such changes from the preliminary certificate as Engineer believes justified after consideration of any objections from Owner.
- D. At the time of receipt of the preliminary certificate of Substantial Completion, Owner and Contractor will confer regarding Owner's use or occupancy of the Work following Substantial Completion, review the builder's risk insurance policy with respect to the end of the builder's risk coverage, and confirm the transition to coverage of the Work under a permanent property insurance policy held by Owner. Unless Owner and Contractor agree otherwise in writing, Owner shall bear responsibility for security, operation, protection of the Work, property insurance, maintenance, heat, and utilities upon Owner's use or occupancy of the Work.
- E. After Substantial Completion the Contractor shall promptly begin work on the punch list of items to be completed or corrected prior to final payment. In appropriate cases Contractor may submit monthly Applications for Payment for completed punch list items, following the progress payment procedures set forth above.
- F. Owner shall have the right to exclude Contractor from the Site after the date of Substantial Completion subject to allowing Contractor reasonable access to remove its property and complete or correct items on the punch list.

15.04 *Partial Use or Occupancy*

- A. Prior to Substantial Completion of all the Work, Owner may use or occupy any substantially completed part of the Work which has specifically been identified in the Contract Documents, or which Owner, Engineer, and Contractor agree constitutes a separately functioning and usable part of the Work that can be used by Owner for its intended purpose without

significant interference with Contractor's performance of the remainder of the Work, subject to the following conditions:

1. At any time, Owner may request in writing that Contractor permit Owner to use or occupy any such part of the Work that Owner believes to be substantially complete. If and when Contractor agrees that such part of the Work is substantially complete, Contractor, Owner, and Engineer will follow the procedures of Paragraph 15.03.A through 15.03.E for that part of the Work.
2. At any time, Contractor may notify Owner and Engineer in writing that Contractor considers any such part of the Work substantially complete and request Engineer to issue a certificate of Substantial Completion for that part of the Work.
3. Within a reasonable time after either such request, Owner, Contractor, and Engineer shall make an inspection of that part of the Work to determine its status of completion. If Engineer does not consider that part of the Work to be substantially complete, Engineer will notify Owner and Contractor in writing giving the reasons therefor. If Engineer considers that part of the Work to be substantially complete, the provisions of Paragraph 15.03 will apply with respect to certification of Substantial Completion of that part of the Work and the division of responsibility in respect thereof and access thereto.
4. No use or occupancy or separate operation of part of the Work may occur prior to compliance with the requirements of Paragraph 6.04 regarding builder's risk or other property insurance.

15.05 *Final Inspection*

- A. Upon written notice from Contractor that the entire Work or an agreed portion thereof is complete, Engineer will promptly make a final inspection with Owner and Contractor and will notify Contractor in writing of all particulars in which this inspection reveals that the Work, or agreed portion thereof, is incomplete or defective. Contractor shall immediately take such measures as are necessary to complete such Work or remedy such deficiencies.

15.06 *Final Payment*

A. *Application for Payment*

1. After Contractor has, in the opinion of Engineer, satisfactorily completed all corrections identified during the final inspection and has delivered, in accordance with the Contract Documents, all maintenance and operating instructions, schedules, guarantees, bonds, certificates or other evidence of insurance, certificates of inspection, annotated record documents (as provided in Paragraph 7.12), and other documents, Contractor may make application for final payment.
2. The final Application for Payment must be accompanied (except as previously delivered) by:
 - a. all documentation called for in the Contract Documents;
 - b. consent of the surety, if any, to final payment;
 - c. satisfactory evidence that all title issues have been resolved such that title to all Work, materials, and equipment has passed to Owner free and clear of any Liens or other title defects, or will so pass upon final payment.

- d. a list of all duly pending Change Proposals and Claims; and
 - e. complete and legally effective releases or waivers (satisfactory to Owner) of all Lien rights arising out of the Work, and of Liens filed in connection with the Work.
3. In lieu of the releases or waivers of Liens specified in Paragraph 15.06.A.2 and as approved by Owner, Contractor may furnish receipts or releases in full and an affidavit of Contractor that: (a) the releases and receipts include all labor, services, material, and equipment for which a Lien could be filed; and (b) all payrolls, material and equipment bills, and other indebtedness connected with the Work for which Owner might in any way be responsible, or which might in any way result in liens or other burdens on Owner's property, have been paid or otherwise satisfied. If any Subcontractor or Supplier fails to furnish such a release or receipt in full, Contractor may furnish a bond or other collateral satisfactory to Owner to indemnify Owner against any Lien, or Owner at its option may issue joint checks payable to Contractor and specified Subcontractors and Suppliers.
- B. *Engineer's Review of Final Application and Recommendation of Payment:* If, on the basis of Engineer's observation of the Work during construction and final inspection, and Engineer's review of the final Application for Payment and accompanying documentation as required by the Contract Documents, Engineer is satisfied that the Work has been completed and Contractor's other obligations under the Contract have been fulfilled, Engineer will, within 10 days after receipt of the final Application for Payment, indicate in writing Engineer's recommendation of final payment and present the final Application for Payment to Owner for payment. Such recommendation will account for any set-offs against payment that are necessary in Engineer's opinion to protect Owner from loss for the reasons stated above with respect to progress payments. Otherwise, Engineer will return the Application for Payment to Contractor, indicating in writing the reasons for refusing to recommend final payment, in which case Contractor shall make the necessary corrections and resubmit the Application for Payment.
- C. *Notice of Acceptability:* In support of its recommendation of payment of the final Application for Payment, Engineer will also give written notice to Owner and Contractor that the Work is acceptable, subject to stated limitations in the notice and to the provisions of Paragraph 15.07.
- D. *Completion of Work:* The Work is complete (subject to surviving obligations) when it is ready for final payment as established by the Engineer's written recommendation of final payment and issuance of notice of the acceptability of the Work.
- E. *Final Payment Becomes Due:* Upon receipt from Engineer of the final Application for Payment and accompanying documentation, Owner shall set off against the amount recommended by Engineer for final payment any further sum to which Owner is entitled, including but not limited to set-offs for liquidated damages and set-offs allowed under the provisions of this Contract with respect to progress payments. Owner shall pay the resulting balance due to Contractor within 30 days of Owner's receipt of the final Application for Payment from Engineer.

15.07 *Waiver of Claims*

- A. By making final payment, Owner waives its claim or right to liquidated damages or other damages for late completion by Contractor, except as set forth in an outstanding Claim,

appeal under the provisions of Article 17, set-off, or express reservation of rights by Owner. Owner reserves all other claims or rights after final payment.

- B. The acceptance of final payment by Contractor will constitute a waiver by Contractor of all claims and rights against Owner other than those pending matters that have been duly submitted as a Claim, or appealed under the provisions of Article 17.

15.08 *Correction Period*

- A. If within one year after the date of Substantial Completion (or such longer period of time as may be prescribed by the Supplementary Conditions or the terms of any applicable special guarantee required by the Contract Documents), Owner gives Contractor written notice that any Work has been found to be defective, or that Contractor's repair of any damages to the Site or adjacent areas has been found to be defective, then after receipt of such notice of defect Contractor shall promptly, without cost to Owner and in accordance with Owner's written instructions:
 - 1. correct the defective repairs to the Site or such adjacent areas;
 - 2. correct such defective Work;
 - 3. remove the defective Work from the Project and replace it with Work that is not defective, if the defective Work has been rejected by Owner, and
 - 4. satisfactorily correct or repair or remove and replace any damage to other Work, to the work of others, or to other land or areas resulting from the corrective measures.
- B. Owner shall give any such notice of defect within 60 days of the discovery that such Work or repairs is defective. If such notice is given within such 60 days but after the end of the correction period, the notice will be deemed a notice of defective Work under Paragraph 7.17.B.
- C. If, after receipt of a notice of defect within 60 days and within the correction period, Contractor does not promptly comply with the terms of Owner's written instructions, or in an emergency where delay would cause serious risk of loss or damage, Owner may have the defective Work corrected or repaired or may have the rejected Work removed and replaced. Contractor shall pay all costs, losses, and damages (including but not limited to all fees and charges of engineers, architects, attorneys, and other professionals and all court or arbitration or other dispute resolution costs) arising out of or relating to such correction or repair or such removal and replacement (including but not limited to all costs of repair or replacement of work of others). Contractor's failure to pay such costs, losses, and damages within 10 days of invoice from Owner will be deemed the start of an event giving rise to a Claim under Paragraph 12.01.B, such that any related Claim must be brought within 30 days of the failure to pay.
- D. In special circumstances where a particular item of equipment is placed in continuous service before Substantial Completion of all the Work, the correction period for that item may start to run from an earlier date if so provided in the Specifications.
- E. Where defective Work (and damage to other Work resulting therefrom) has been corrected or removed and replaced under this paragraph, the correction period hereunder with respect to such Work will be extended for an additional period of one year after such correction or removal and replacement has been satisfactorily completed.

- F. Contractor's obligations under this paragraph are in addition to all other obligations and warranties. The provisions of this paragraph are not to be construed as a substitute for, or a waiver of, the provisions of any applicable statute of limitation or repose.

ARTICLE 16—SUSPENSION OF WORK AND TERMINATION

16.01 *Owner May Suspend Work*

- A. At any time and without cause, Owner may suspend the Work or any portion thereof for a period of not more than 90 consecutive days by written notice to Contractor and Engineer. Such notice will fix the date on which Work will be resumed. Contractor shall resume the Work on the date so fixed. Contractor shall be entitled to an adjustment in the Contract Price or an extension of the Contract Times directly attributable to any such suspension. Any Change Proposal seeking such adjustments must be submitted no later than 30 days after the date fixed for resumption of Work.

16.02 *Owner May Terminate for Cause*

- A. The occurrence of any one or more of the following events will constitute a default by Contractor and justify termination for cause:
 - 1. Contractor's persistent failure to perform the Work in accordance with the Contract Documents (including, but not limited to, failure to supply sufficient skilled workers or suitable materials or equipment, or failure to adhere to the Progress Schedule);
 - 2. Failure of Contractor to perform or otherwise to comply with a material term of the Contract Documents;
 - 3. Contractor's disregard of Laws or Regulations of any public body having jurisdiction; or
 - 4. Contractor's repeated disregard of the authority of Owner or Engineer.
- B. If one or more of the events identified in Paragraph 16.02.A occurs, then after giving Contractor (and any surety) 10 days' written notice that Owner is considering a declaration that Contractor is in default and termination of the Contract, Owner may proceed to:
 - 1. declare Contractor to be in default, and give Contractor (and any surety) written notice that the Contract is terminated; and
 - 2. enforce the rights available to Owner under any applicable performance bond.
- C. Subject to the terms and operation of any applicable performance bond, if Owner has terminated the Contract for cause, Owner may exclude Contractor from the Site, take possession of the Work, incorporate in the Work all materials and equipment stored at the Site or for which Owner has paid Contractor but which are stored elsewhere, and complete the Work as Owner may deem expedient.
- D. Owner may not proceed with termination of the Contract under Paragraph 16.02.B if Contractor within 7 days of receipt of notice of intent to terminate begins to correct its failure to perform and proceeds diligently to cure such failure.
- E. If Owner proceeds as provided in Paragraph 16.02.B, Contractor shall not be entitled to receive any further payment until the Work is completed. If the unpaid balance of the Contract Price exceeds the cost to complete the Work, including all related claims, costs, losses, and damages (including but not limited to all fees and charges of engineers, architects,

attorneys, and other professionals) sustained by Owner, such excess will be paid to Contractor. If the cost to complete the Work including such related claims, costs, losses, and damages exceeds such unpaid balance, Contractor shall pay the difference to Owner. Such claims, costs, losses, and damages incurred by Owner will be reviewed by Engineer as to their reasonableness and, when so approved by Engineer, incorporated in a Change Order. When exercising any rights or remedies under this paragraph, Owner shall not be required to obtain the lowest price for the Work performed.

- F. Where Contractor's services have been so terminated by Owner, the termination will not affect any rights or remedies of Owner against Contractor then existing or which may thereafter accrue, or any rights or remedies of Owner against Contractor or any surety under any payment bond or performance bond. Any retention or payment of money due Contractor by Owner will not release Contractor from liability.
- G. If and to the extent that Contractor has provided a performance bond under the provisions of Paragraph 6.01.A, the provisions of that bond will govern over any inconsistent provisions of Paragraphs 16.02.B and 16.02.D.

16.03 *Owner May Terminate for Convenience*

- A. Upon 7 days' written notice to Contractor and Engineer, Owner may, without cause and without prejudice to any other right or remedy of Owner, terminate the Contract. In such case, Contractor shall be paid for (without duplication of any items):
 - 1. completed and acceptable Work executed in accordance with the Contract Documents prior to the effective date of termination, including fair and reasonable sums for overhead and profit on such Work;
 - 2. expenses sustained prior to the effective date of termination in performing services and furnishing labor, materials, or equipment as required by the Contract Documents in connection with uncompleted Work, plus fair and reasonable sums for overhead and profit on such expenses; and
 - 3. other reasonable expenses directly attributable to termination, including costs incurred to prepare a termination for convenience cost proposal.
- B. Contractor shall not be paid for any loss of anticipated profits or revenue, post-termination overhead costs, or other economic loss arising out of or resulting from such termination.

16.04 *Contractor May Stop Work or Terminate*

- A. If, through no act or fault of Contractor, (1) the Work is suspended for more than 90 consecutive days by Owner or under an order of court or other public authority, or (2) Engineer fails to act on any Application for Payment within 30 days after it is submitted, or (3) Owner fails for 30 days to pay Contractor any sum finally determined to be due, then Contractor may, upon 7 days' written notice to Owner and Engineer, and provided Owner or Engineer do not remedy such suspension or failure within that time, terminate the contract and recover from Owner payment on the same terms as provided in Paragraph 16.03.
- B. In lieu of terminating the Contract and without prejudice to any other right or remedy, if Engineer has failed to act on an Application for Payment within 30 days after it is submitted, or Owner has failed for 30 days to pay Contractor any sum finally determined to be due, Contractor may, 7 days after written notice to Owner and Engineer, stop the Work until payment is made of all such amounts due Contractor, including interest thereon. The

provisions of this paragraph are not intended to preclude Contractor from submitting a Change Proposal for an adjustment in Contract Price or Contract Times or otherwise for expenses or damage directly attributable to Contractor's stopping the Work as permitted by this paragraph.

ARTICLE 17—FINAL RESOLUTION OF DISPUTES

17.01 *Methods and Procedures*

- A. *Disputes Subject to Final Resolution:* The following disputed matters are subject to final resolution under the provisions of this article:
1. A timely appeal of an approval in part and denial in part of a Claim, or of a denial in full, pursuant to Article 12; and
 2. Disputes between Owner and Contractor concerning the Work, or obligations under the Contract Documents, that arise after final payment has been made.
- B. *Final Resolution of Disputes:* For any dispute subject to resolution under this article, Owner or Contractor may:
1. elect in writing to invoke the dispute resolution process provided for in the Supplementary Conditions;
 2. agree with the other party to submit the dispute to another dispute resolution process; or
 3. if no dispute resolution process is provided for in the Supplementary Conditions or mutually agreed to, give written notice to the other party of the intent to submit the dispute to a court of competent jurisdiction.

ARTICLE 18—MISCELLANEOUS

18.01 *Giving Notice*

- A. Whenever any provision of the Contract requires the giving of written notice to Owner, Engineer, or Contractor, it will be deemed to have been validly given only if delivered:
1. in person, by a commercial courier service or otherwise, to the recipient's place of business;
 2. by registered or certified mail, postage prepaid, to the recipient's place of business; or
 3. by e-mail to the recipient, with the words "Formal Notice" or similar in the e-mail's subject line.

18.02 *Computation of Times*

- A. When any period of time is referred to in the Contract by days, it will be computed to exclude the first and include the last day of such period. If the last day of any such period falls on a Saturday or Sunday or on a day made a legal holiday by the law of the applicable jurisdiction, such day will be omitted from the computation.

18.03 *Cumulative Remedies*

- A. The duties and obligations imposed by these General Conditions and the rights and remedies available hereunder to the parties hereto are in addition to, and are not to be construed in any way as a limitation of, any rights and remedies available to any or all of them which are otherwise imposed or available by Laws or Regulations, by special warranty or guarantee, or by other provisions of the Contract. The provisions of this paragraph will be as effective as if repeated specifically in the Contract Documents in connection with each particular duty, obligation, right, and remedy to which they apply.

18.04 *Limitation of Damages*

- A. With respect to any and all Change Proposals, Claims, disputes subject to final resolution, and other matters at issue, neither Owner nor Engineer, nor any of their officers, directors, members, partners, employees, agents, consultants, or subcontractors, shall be liable to Contractor for any claims, costs, losses, or damages sustained by Contractor on or in connection with any other project or anticipated project.

18.05 *No Waiver*

- A. A party's non-enforcement of any provision will not constitute a waiver of that provision, nor will it affect the enforceability of that provision or of the remainder of this Contract.

18.06 *Survival of Obligations*

- A. All representations, indemnifications, warranties, and guarantees made in, required by, or given in accordance with the Contract, as well as all continuing obligations indicated in the Contract, will survive final payment, completion, and acceptance of the Work or termination of the Contract or of the services of Contractor.

18.07 *Controlling Law*

- A. This Contract is to be governed by the law of the state in which the Project is located.

18.08 *Assignment of Contract*

- A. Unless expressly agreed to elsewhere in the Contract, no assignment by a party to this Contract of any rights under or interests in the Contract will be binding on the other party without the written consent of the party sought to be bound; and, specifically but without limitation, money that may become due and money that is due may not be assigned without such consent (except to the extent that the effect of this restriction may be limited by law), and unless specifically stated to the contrary in any written consent to an assignment, no assignment will release or discharge the assignor from any duty or responsibility under the Contract.

18.09 *Successors and Assigns*

- A. Owner and Contractor each binds itself, its successors, assigns, and legal representatives to the other party hereto, its successors, assigns, and legal representatives in respect to all covenants, agreements, and obligations contained in the Contract Documents.

18.10 *Headings*

- A. Article and paragraph headings are inserted for convenience only and do not constitute parts of these General Conditions.

SECTION 007300 - SUPPLEMENTARY CONDITIONS
TABLE OF CONTENTS

PART I - AMENDMENTS TO GENERAL CONDITIONS

Article Number	Title
1	DEFINITIONS AND TERMINOLOGY
2	PRELIMINARY MATTERS
3	DOCUMENTS; INTENT, REQUIREMENTS, REUSE
4	COMMENCEMENT AND PROGRESS OF THE WORK
5	SITE; SUBSURFACE AND PHYSICAL CONDITIONS; HAZARDOUS ENVIRONMENTAL CONDITIONS
6	BONDS AND INSURANCE
7	CONTRACTOR'S RESPONSIBILITIES
8	OTHER WORK AT THE SITE
9	OWNER'S RESPONSIBILITIES
10	ENGINEER'S STATUS DURING CONSTRUCTION
11	AMENDING THE CONTRACT DOCUMENTS; CHANGES IN THE WORK
13	COST OF THE WORK; ALLOWANCES; UNIT PRICE WORK
14	TESTS AND INSPECTIONS; CORRECTION, REMOVAL OR ACCEPTANCE OF DEFECTIVE WORK
15	PAYMENTS TO CONTRACTOR; SET-OFFS; COMPLETION; CORRECTION PERIOD
16	SUSPENSION OF WORK AND TERMINATION
17	FINAL RESOLUTION OF DISPUTES
18	MISCELLANEOUS

PART II - FEDERAL, STATE AND LOCAL GOVERNMENT PROVISIONS

- 1.0. FEDERAL GOVERNMENT PROVISIONS
- 2.0. STATE GOVERNMENT PROVISIONS
- 3.0. CITY OF PROVIDENCE RHODE ISLAND PROVISIONS

SECTION 007300 - SUPPLEMENTARY CONDITIONS

PART 1 - AMENDMENTS TO GENERAL CONDITIONS

These Supplementary Conditions amend or supplement the Standard General Conditions of the Construction Contract (EJCDC Document No. C-700, 2018 edition) and other provisions of the Contract Documents as indicated below. All provisions which are not so amended or supplemented remain in full force and effect.

ARTICLE 1 - DEFINITIONS AND TERMINOLOGY

SC-1.01A.7.

Delete Paragraph 1.01A.7 of the General Conditions in its entirety and replace it with the following:

7. Bidding Requirements - The Advertisement or Request for Proposals, Invitation to Bid, Instructions to Bidders, Information Available to Bidders, Bid Security Form, if any, and the bid form with any supplements.

SC-1.01A.15

Delete Paragraph 1.01A.15 of the General Conditions in its entirety and replace it with the following:

15. Contract Times - The number of days or dates stated in the Contract Documents and in the Agreement to: (I) achieve substantial completion; and (II) complete the Work so that it is ready for final payment as evidenced by Engineer's written recommendation of final payment.

SC-1.01A.22

Delete Paragraph 1.01A.22 of the General Conditions in its entirety and replace it with the following:

22. Engineer - The individual or entity named as such elsewhere in the Contract Documents or as designated by the Owner. The Owner may act in the Engineer's capacity at its sole discretion if another individual or entity is not so named, in which case where the word Engineer is used the word Owner may be substituted at the Owner's sole discretion.

SC-1.01A.39.

Delete paragraph 1.01A.39. of the General Conditions in its entirety and replace with the following:

39. Specifications - Sections included under Division 00 through Division 16 of the Project Manual.

SC-1.01A51

Add the following new paragraphs immediately after Paragraph 1.01A.50 of the General Conditions which is to read as follows:

51. *Cover Documents*—City of Providence, Rhode Island documents found at the beginning of the Bidding Documents, which provide City of Providence terms and requirements for bidding and for the Contract. The title of these documents may include but are not limited to “Board of Contract and Supply, City of Providence, Rhode Island, Request For Proposals”.

52. *Build America, Buy America Act (BABAA)* – Requirements instituted by the Bipartisan Infrastructure Law of 2021 mandating domestic preference that all iron and steel, manufactured products, and construction materials are produced in the United States.

53. *Construction Materials* – Those articles, materials, or supply, - other than an item of primarily iron or steel; a manufactured product; cement and cementitious materials; aggregates such as stone, sand, or gravel; or aggregate binding agents or additives – that are or consist primarily of: non-ferrous metals, plastic and polymer-based products, glass, lumber, or drywall.

54. *Manufactured Product* – Items assembled out of components, or otherwise made or processed from raw materials into finished products. Manufactured products must be manufactured (assembled) in the United States, and the cost of components that were mined, produced, or manufactured in the United States must be greater than 55 percent of the total cost of all components of the project.

55. *Manufacturer’s Certification* – Documentation provided by a Manufacturer, certifying that the items provided by Manufacturer meet the domestic preference requirements of BABAA.

ARTICLE 2 - PRELIMINARY MATTERS

SC-2.01A.

Delete Paragraph 2.01A of the General Conditions in its entirety and replace it with the following:

A. Performance and Payment Bonds: Within ten (10) calendar days following the receipt of a Notice to Award, the Contractor shall deliver the required bonds to the Owner for preparation of the Contract Agreement by Owner.

SC-2.01B.

Add the following new sentence at the end of this paragraph:

The Contractor shall file the original and one certified copy of all policies with the Owner before exposure to loss may occur. If the Owner is damaged by failure of the Contractor to maintain such insurance and to so notify the Owner, then the Contractor shall bear all responsible costs properly attributable thereto.

SC-2.01C.

Delete Paragraph 2.01C of the General Conditions in its entirety.

SC-2.02A.

Delete "four" in the first line and replace with "one."

SC-2.03A.4

Add the following new paragraph immediately after Paragraph 2.03A.3 of the General Conditions which is to read as follows:

4. Contractor shall prepare all schedules in a format approved by the Owner and compatible with the complexity of the project to adequately illustrate the relationship of major work activities. Minimum requirements will include a horizontal bar chart on a monthly time scale, with separate activities conforming to major divisions of the Specifications. Projected percentage completion of each activity and cumulative total of all activities should be shown for the first day of each month throughout the projected contract duration.

ARTICLE 3 – CONTRACT DOCUMENTS: INTENT, REQUIREMENTS, REUSE

SC-3.01H.

Add the following new paragraph immediately after Paragraph 3.01G. of the General Conditions which is to read as follows:

H. Each and every provision of law and clause required by law to be inserted in these Contract Documents shall be deemed to be inserted herein, and they shall be read and enforced as though they were included herein, and if through mistake or otherwise, any such provision is not inserted, or if not correctly inserted, then upon the application of either party, the Contract Documents shall forthwith be physically amended to make such insertion.

SC-3.03B.2.

Add the following new paragraph immediately after Paragraph 3.03B.1.b of the General Conditions which is to read as follows:

2. In case of a discrepancy between the requirements of the Cover Documents and the requirements stated in other sections of the Contract Documents, the requirements stated in the Cover Documents shall prevail.

SC-3.03C.

Add the following new paragraph immediately after Paragraph 3.03B.2 of the General Conditions which is to read as follows:

C. In case of conflict as to the type or quality of materials to be supplied, the Contractor shall provide the best quality of materials, unless otherwise directed by the Owner.

ARTICLE 4 - COMMENCEMENT AND PROGRESS OF THE WORK

SC-4.01A.

Delete Paragraph 4.01A of the General Conditions in its entirety and replace with the following:

A. The Contract Time will commence to run as indicated in the Contract Documents. If not specifically stated in the Contract Documents, the Contract Times will commence to run on the thirtieth day after the Effective Date of Agreement or, if a Notice to Proceed is given, on the day indicated in the Notice to Proceed.

SC-4.03B.

Add the following new paragraph immediately after Paragraph 4.03A of the General Conditions which is to read as follows:

B. Engineer may check the lines, elevations, reference marks, batter boards, etc., set by Contractor, and Contractor shall correct any errors disclosed by such check. Such a check shall not be considered approval of Contractor's work and shall not relieve Contractor of the responsibility for accurate construction of the entire Work. Contractor shall furnish personnel to assist Engineer in checking lines and grades.

SC-4.04A.3.

Add the following new paragraph immediately after Paragraph 4.04.A.2 of the General Conditions which is to read as follows:

3. Submit periodic updates as necessary to reflect any deviations of actual progress from the initial schedule.

ARTICLE 5 - SITE; SUBSURFACE AND PHYSICAL CONDITIONS; HAZARDOUS ENVIRONMENTAL CONDITIONS

SC-5.01A.1.

Add the following new paragraph immediately after Paragraph 5.01A. of the General Conditions which is to read as follows:

1. If all lands and rights-of-way are not obtained as herein contemplated before construction begins, Contractor shall begin the Work upon such land and rights-of-way as Owner has previously acquired.

SC-5.01B.

Delete Paragraph 5.01.B of the General Conditions in its entirety and relabel the subsequent Paragraph 5.01.C to 5.01.B.

SC-5.03A.

Delete Paragraphs 5.03A and 5.03B in their entirety and insert the following:

A. No reports of explorations or tests of subsurface conditions at or adjacent to the Site, or drawings of physical conditions relating to existing surface or subsurface structures at the Site, are known to Owner.

5.03D.

Delete Paragraph 5.03D of the General Conditions in its entirety and replace it with the following:

D. Limited Reliance by CONTRACTOR on Technical Data Authorized: CONTRACTOR may rely upon the general accuracy of the “technical data” contained in such reports and drawings, but such reports and drawings are not Contract Documents. Such “technical data”, if any, will be specifically identified and defined in the Bidding Documents, if applicable. Except for such reliance on such “technical data,” CONTRACTOR may not rely upon or make any Claim against OWNER, ENGINEER, or any of the ENGINEER’s Consultants with respect to:”

SC 5.04E.1.

Add the following new paragraph immediately after Paragraph 5.04.E.1.c of the General Conditions which is to read as follows:

d. the provisions of this paragraph are not in conflict with other provisions of the Contract Documents.

SC-5.06A.

Delete Paragraphs 5.06A and 5.06B in their entirety and insert the following:

A. No reports or drawings related to Hazardous Environmental Conditions at the Site, are known to Owner.

SC-5.06B.

Delete Paragraph 506.B of the General Conditions in its entirety and replace it with the following:

B. Limited Reliance by CONTRACTOR on Technical Data Authorized: CONTRACTOR may rely upon the general accuracy of the “technical data” contained in such reports and drawings, but such reports and drawings are not Contract Documents. Such “technical data”, if any, will be specifically identified and defined in the Bidding Documents, if applicable. Except for such reliance on such “technical data,” CONTRACTOR may not rely upon or make any Claim against OWNER, ENGINEER or any of ENGINEER’s Consultants with respect to:”

ARTICLE 6 - BONDS AND INSURANCE

SC-6.01A.

Add the following new sentences immediately following the first sentence of paragraph 6.01A:

If the Contract is for a multiple year period, the Owner reserves the right to direct the Contractor to supply bonding for one-year periods, but such bonds must be renewed prior to expiration during the required period; it is the Contractor’s responsibility to renew such bonds and provide proof of such renewal to the Owner without notice from the Owner. Failure to renew such bonds before expiration will result in termination of the Contract by the Owner and liquidated damages may apply.

SC-6.01B.1.

Add the following paragraph immediately after Paragraph 6.01B of the General Conditions:

1. Contractor shall furnish Efficiency Guarantee Bonds in accordance with Article entitled MANUFACTURER'S EXPERIENCE in the Instructions to Bidders and executed on forms approved by the Owner.

SC-6.01C.

Add the following new sentences at the end of paragraph 6.01C:

Bonds shall be executed by a company licensed to do business in the State of Rhode Island. All out-of-state corporations must add the following language to the original bond: “[Name of Incorporating State] corporation, authorized to do business in the State of Rhode Island.” A private individual will not be accepted as a surety to provide the required bonds.

SC-6.01I.

Add the following new paragraph immediately after Paragraph 6.01.H of the General Conditions which is to read as follows:

I. The reference to the Contract Date on the bond must be left blank. This date will be filled in upon execution of the Contract by the Owner. The Contractor must submit all required Bonds to the Owner within 10 calendar days after notification of award of the Contract. If the required Bonds are not submitted to the Owner by the required date, the Owner may cancel the award of the Contract and award the Contract to another bidder. The original and one copy of the required Bonds must be submitted to Providence Water, 125 Dupont Drive, Providence, Rhode Island 02907 Attn: Purchasing Department. Any costs incurred from obtaining the required Bonds shall be solely the responsibility of the Contractor and shall be included in the prices bid, unless a specific bid line item on the Bid Forms provides separately for them as an additional cost or allowance.

SC-6.02D

Add the following paragraphs immediately after Paragraph 6.02D of the General Conditions which are to read as follows:

1. Contractor shall provide evidence of its insurance coverage on the ACORD certificate of insurance form and shall include the following statement in its entirety in the section of the form entitled “Description of Operations/Locations/Vehicles/Special Items”.

2. The City of Providence, Rhode Island; Providence Water Supply Board; and CDM Smith Inc., and their subsidiaries, officers, directors, partners, employees and other consultants and subcontractors are named as additional insureds with respect to the insured’s Commercial General Liability, Automobile Liability and Pollution Liability Insurance Policies. All insurers waive all rights of subrogation against the City of Providence, Rhode Island; Providence Water Supply Board; and CDM Smith Inc., their subsidiaries, officers, directors, partners, employees and other consultants and subcontractors. All insurance is primary for all claims covered thereby. Commercial General Liability Insurance includes contractual liability coverage.

3. The insured name must be the same name as the name on the Bid submitted.

4. Insurance Certificates must state the title of the Project to be performed.

5. Certificate Holder provision of the certificates must list “City of Providence and Providence Water”.
6. Cancellation and/or reduction in coverage must provide 30 days written notice.
7. The Successful Bidder must produce satisfactory Certificates of Insurance within 10 days following a Notice of Award. The Contract shall not be executed, and no work shall begin unless all these requirements are satisfied. Failure to do so may result in the cancellation of an award and award to another bidder.
 - a. The insurance coverages specified shall be carried until all the Work required to be completed per the Contract Documents and Contract are satisfactorily completed by the Contractor and for a period of at least two years after the date when final payment becomes due. Failure to carry or keep such insurance in force shall constitute a violation of the Contract, and Owner maintains the right to stop work and/or withhold payment until proper evidence of insurance is provided.
 - b. The insurance shall provide for 30 days prior written notice to be given to Owner in the event coverage is substantially changed, canceled or not renewed.
 - c. In no case shall the coverage limits for Commercial General Liability, Automobile Liability, or Professional Liability Insurance stated above be less than the total Contract amount. If the total Contract amount exceeds any stated limit, the limit shall be adjusted to the satisfaction of the Owner to the next highest \$1,000,000 exceeding the total Contract amount.
 - d. Owner maintains the right to modify, delete, alter or change these requirements.
 - e. The Successful Bidder understands and agrees that any insurance protection furnished by the Contractor hereunder shall in no way limit its responsibility to indemnify and save harmless Owner, CDM Smith, and their officers, agents, directors, partners, employees and other consultants and subcontractors.
 - f. For additional information, contact the Purchasing Department of Providence Water at (401) 521-6300 Ext. 7227.

SC-6.02E.

Delete paragraph 6.02E of the General Conditions in its entirety and replace with the following which is to read as follows:

E. The Contractor shall send the original and one copy of all Certificates of Insurance required by Contract Documents to Providence Water, 125 Dupont Drive, Providence, Rhode Island 02907 Attn: Purchasing Department. These Certificates shall be furnished to the Owner within 10 days of a Notice of Award of the Contract and will be attached to the final executed copies of the Contract. The Certificates must be completely filled out listing all insurance companies, evidence of the coverages and limits set forth by the Contract Documents, and additional insureds. The Certificates shall be on standard insurance Accord Forms.

SC-6.02O.

Add the following new paragraph immediately after new Paragraph 6.02N of the General Conditions which is to read as follows and re-letter all following paragraphs:

O. The Owner shall be notified immediately by the Contractor and the insurance company of their termination or cancellation of the policy or coverages, and the protection shall be renewed before further work will be permitted at the site(s) of the Contract. The Contractor shall not cause any policy or coverage to be canceled or permit them to lapse or be subject to cancellation or a reduction in the required limits of liability or amounts of insurance. Copies of any endorsements that are subsequently issued amending coverages or limits shall immediately be furnished to the Owner.

SC-6.03A.

Insert the words “from a company or companies licensed to do business in the State in which the Project is located” immediately following the word “insurance” in the second line.

SC-6.03A.1

Add the following paragraph immediately after Paragraph 6.03A of the General Conditions:

1. Contractor’s Insurance

a. Workers' Compensation: Contractor shall purchase and maintain workers’ compensation and employer’s liability insurance for:

1. claims under workers’ compensation, disability benefits, and other similar employee benefit acts.
2. United States Longshoreman and Harbor Workers’ Compensation Act and Jones Act coverage (if applicable).
3. claims for damages because of bodily injury, occupational sickness or disease, or death of Contractor’s employees (by stop-gap endorsement in monopolist worker’s compensation states).
4. Foreign voluntary worker compensation (if applicable)
5. Stop Gap Employer Liability for work in ND, OH, WA, WY & Puerto Rico
6. The limits of liability for the workers compensation insurance required by Paragraph 6.03 of the General Conditions shall provide coverage for not less than the following amounts or greater where required by law.

(1) Worker's Compensation	Statutory
(2) Employer's Liability	\$1,000,000 Each Occurrence \$1,000,000 Disease per employee

b. Commercial General Liability – Claims Covered: Contractor shall purchase and maintain commercial general liability insurance, covering all operations by or on behalf of Contractor, on an occurrence basis, against:

1. claims for damages because of bodily injury, sickness or disease, or death of any person other than Contractor’s employees.
2. claims for damages insured by reasonably available personal injury liability coverage.
3. claims for damages, other than to the Work itself, because of injury to or destruction of tangible property wherever located, including loss of use resulting therefrom.
4. Contractor’s commercial liability policy shall be written on a 1996 (or later) ISO commercial general liability form (occurrence form) and include the following coverages and endorsements:

5. Products and completed operations coverage:
 - 1) Such insurance shall be maintained for three years after final payment.
 - 2) Contractor shall furnish Owner and each other additional insured (as identified in the Supplementary Conditions or elsewhere in the Contract) evidence of continuation of such insurance at final payment and three years thereafter.
6. Blanket contractual liability coverage, to the extent permitted by law, including but not limited to tort liability and coverage of Contractor’s contractual indemnity obligations in Paragraph 7.18.
7. Severability of interest.
8. Underground, explosion, and collapse coverage.
9. Personal injury coverage.
10. Additional insured endorsements that include both ongoing operations and products and completed operations coverage through ISO Endorsements CG 20 10 10 01 and CG 20 37 10 01 (together); or CG 20 10 07 04 and CG 20 37 07 04 (together); or their equivalent.
11. For design professional additional insureds, ISO Endorsement CG 20 32 07 04, “Additional Insured—Engineers, Architects or Surveyors Not Engaged by the Named Insured” or its equivalent.
12. There shall be no specific exclusions associated with scope or work or any cross-suit exclusions for Additional Insureds.
13. Commercial General Liability Insurance shall not be less than the following amounts.

Bodily Injury:	\$2,000,000	Each Occurrence
	\$4,000,000	Annual Aggregate
Property Damage:	\$2,000,000	Each Occurrence
	\$4,000,000	Annual Aggregate
Personal Injury:	\$4,000,000	Annual Aggregate

- c. Comprehensive Automobile Liability including all owned (private and others), hired and non-owned vehicles, including contractual liability coverage and MCS-90 endorsement if Contractor is hauling goods:

Bodily Injury	\$1,000,000	
Each Person	\$1,000,000	Each Accident
Property Damage: Each accident [or] Combined Single Limit of	\$1,000,000	Each Occurrence

- d. Umbrella or Excess Liability:

Per Occurrence	\$5,000,000
General Aggregate	\$5,000,000

- e. Contractor’s Pollution Liability:

Each Occurrence	\$2,000,000
General Aggregate	\$2,000,000

If box is checked, Contractor is required to provide Contractor's Pollution Liability insurance under this Contract.

f. Contractor's Professional Liability:

Each Claim	\$1,000,000
Annual Aggregate	\$2,000,000

If box is checked, Contractor is required to provide Contractor's Professional Liability insurance under this Contract.

SC 6.03B.6.

Add the following new subparagraph after subparagraph 6.03B.5 of the General Conditions:

6. All policies of insurance required to be provided by the Contractor shall contain provisions that the insurer(s) waive all rights of subrogation against the Owner, Engineer, and their officers, directors, partners and other consultants and subcontractors of each and any of them and other parties identified in the Supplementary Conditions.

SC-6.03C.1

Add the following two sentences to subparagraph 6.03.C.1 of the General Conditions:

The City of Providence, Rhode Island; Providence Water Supply Board; and CDM Smith Inc., and their subsidiaries officers, directors, partners, employees and other consultants and subcontractors are named as additional insureds. All insurers waive all rights of subrogation against the City of Providence, Rhode Island; Providence Water Supply Board; and CDM Smith Inc., their subsidiaries, officers, directors, partners, employees and other consultants and subcontractors.

SC-6.04.A.

Add the following new subparagraph after Paragraph 6.04.A of the General Conditions:

1. In addition to City of Providence, Rhode Island, Providence Water Supply Board, Contractor, and all Subcontractors, include as insureds the following: CDM Smith Inc., and their subsidiaries, officers, directors, partners, employees and other consultants and subcontractors.
2. include for the benefit of Owner loss of profits and soft cost coverage including, without limitation, fixed expenses and debt service for a minimum of 12 months with a maximum deductible of 30 days, plus attorneys' fees and engineering or other consultants' fees, if not otherwise covered;
3. include by express endorsement coverage of damage to Contractor's equipment.

SC-6.04B.

Delete Paragraph 6.04B of the General Condition in its entirety.

SC-6.04D.

Insert the following at the end of the last sentence of Paragraph 6.04D of the General Conditions:

“at no additional expense to the Owner”

SC-6.04F.

Add Paragraph 6.04.F after Paragraph 6.04E of the General Conditions.

F. All policies required by this Paragraph shall contain provisions to the effect that the insurer(s) waive all rights of subrogation against the Owner, Engineer and their officers, directors, partners, employees and other consultants and subcontractors of each and any of them.

SC-6.07.

Add the following new Paragraph immediately after Paragraph 6.06 of the General Conditions which is to read as follows:

6.07. Other Data

A. In the event the form of any policy or certificate for the amounts of insurance or the companies writing same are not satisfactory to the Owner, the Contractor shall secure other policies or certificates in form and amount and with companies satisfactory to the Owner. The Contractor shall not cause policies to be canceled or permit them to lapse and all insurance policies shall include a clause to the effect that the policy shall not be subject to cancellation or a reduction in the required limits of liability or amounts of insurance until notice has been sent by registered mail to the Owner, stating when, not less than thirty (30) days thereafter, such cancellation or insurance shall take effect. Such notice shall contain true transcripts from the policy, authenticated by the proper officer of the insurer evidencing in particular those insured, the extent of the insurance, the location and operations to which the insurance applies, the expiration date, and the above mentioned notice of cancellation clause. All policies and certificates by the accepted Successful Bidder shall be delivered to the Owner immediately before preparation of the Contract.

ARTICLE 7 - CONTRACTOR'S RESPONSIBILITIES

SC-7.02.

Add the following new paragraphs immediately after Paragraph 7.02B of the General Conditions, which are to read as follows:

C. This Agreement is subject to the applicable provisions of the Contract Work Hours and Safety Standards Act, Public Law 87-581, 87th Congress. No Contractor or Subcontractor contracting for any part of the Work shall require or permit any laborer or mechanic to be employed on the Work in excess of forty hours in any work week unless such laborer or mechanic receives compensation at a rate not less than one and one-half times that person's basic rate of pay for all hours worked in excess of forty hours in such work week.

D. Contractor shall employ only competent persons to do the work and whenever Owner shall notify Contractor, in writing, that any person on the Work appears to be incompetent, disorderly, or otherwise unsatisfactory, such person shall be removed from the Project and shall not again be employed on it except with the consent of Owner.

E. Contractor and Subcontractors shall, insofar as practicable, give preference in the hiring of workers for the Project to qualified local residents with first preference being given to citizens of the United States who have served in the armed forces of the United States and have been honorably discharged therefrom or released from active duty therein.

F. Contractor and all Subcontractors shall pay to all laborers and mechanics employed for the construction covered by this Contract the minimum rates of pay as determined by the Secretary of Labor in accordance with the Act of March 3, 1931, as amended, known as the Davis-Bacon Act (40 U.S.C. 276a through 276a-7). Furthermore, Contractor and Subcontractors shall adhere to the stipulations and provisions published by the Secretary of Health, Education, and Welfare in "Labor Standards (Federal Water Pollution Control Act)." The Wage Rate Schedule as prepared by the Secretary of Labor and the "Labor Standards" are part of this Contract and are included in PART II of these Supplementary Conditions.

G. Except as may be otherwise required by law, all claims and disputes pertaining to the classification of labor employed on the project under this Contract shall be decided by the governing body having jurisdiction.

H. Contractor and all Subcontractors shall comply with the Regulations of the Secretary of Labor made pursuant to the Anti-Kickback Act of June 30, 1940 (40 U.S.C. 276c) and all amendments or modifications thereto. Contractor and all Subcontractors shall furnish Owner with weekly Statements of Compliance. In case of Subcontracts, Contractor shall cause appropriate provision to be inserted in all subcontracts for the Work which Contractor may let to ensure compliance with said Anti-Kickback Act by all Subcontractors subject thereto, and Contractor shall be responsible for the submission of all Statements of Compliance required of Subcontractors by said Anti-Kickback Act except as the Secretary of Labor may specifically provide for reasonable limitations, variations, and exemptions from the requirements thereof. These Regulations are part of this Contract and are included in PART II of these Supplementary Conditions.

I. Prior to work on the project commencing, the Contractor shall provide the Owner with the name and qualifications of its resident superintendent for the work. The superintendent shall be permanently assigned to this project and shall be present at all times during the performance of the work. Any proposed replacement superintendent will be subject to the approval of the Owner. The Contractor shall provide the Owner with the qualifications of any superintendent for review.

SC-7.03C.

Delete Paragraph 7.03C of the General Conditions in its entirety and replace it with the following:

C. Except as otherwise required for the safety or protection of persons or the Work or property at the Site or adjacent thereto, and except as otherwise stated in the Contract Documents, all Work at the Site shall be performed during the Owner's regular working hours, and Contractor will not permit overtime work or performance of Work on Saturday, Sunday, or any holiday observed by the Owner without Owner's written consent (which will not be unreasonably withheld) given after prior written notice to Engineer. Requests to work other than regular working hours shall be submitted to Engineer not less than 48 hours

prior to any proposed weekend work or scheduled extended work weeks. Occasional unscheduled overtime on weekdays may be permitted provided two hours' notice is given to Engineer.

SC-7.03D.

Add the following new paragraph immediately after Paragraph 7.02C of the General Conditions which is to read as follows:

D. Contractor shall reimburse the Owner for additional engineering and/or inspection costs incurred as a result of overtime work in excess of the regular working hours stipulated in Paragraph SC-7.02B. At Owner's option, overtime costs may either be deducted from the Contractor's monthly payment request or deducted from the Contractor's retention prior to release of final payment. Overtime costs for the Owner's personnel shall be based on the individual's current overtime wage rate. Overtime costs for personnel employed by the Engineer or Owner's independent testing laboratory shall be calculated in accordance with the terms of their respective contracts with the Owner.

SC-7.04C.

Add the following new sentences at the end of Paragraph 7.04C of the General Conditions which to read as follows:

All equipment incorporated into the Work shall bear the manufacturer's original identification numbers and nameplates. Manufacturer's identification numbers and nameplates shall not be removed from equipment and shall be protected from damage during installation and during performance of any Work.

SC-7.04D.

Add the following new paragraphs immediately after Paragraph 7.04C of the General Conditions which is to read as follows:

D. Omissions of items from the Drawings and Specifications that are obviously needed to properly perform the Work, such as attachments, bolts, hangers, and other fastening devices, shall not relieve the Contractor from furnishing and installing same to properly perform the required Work. It shall be the Contractor's responsibility to obtain from Engineer all necessary interpretations of the designs, Drawings, and Specifications.

E. All products must meet Build America, Buy America Act (BABAA) requirements.

F. Contractor shall include Manufacturer's Certification for BABAA requirements with all applicable submittals. If a specific manufacturer is used in bidding, a statement that the Manufacturer will comply with BABAA must be included with the bid submission. Contractor shall comply with BABAA requirements, including coordination with manufacturers, distributors, and suppliers to correct deficiencies in any BABAA documentation.

G. Contractor shall certify upon completion that all work and materials have complied with BABAA requirements.

H. Installation of materials or products that are not compliant with BABAA requirements shall be considered defective work. Contractor should ensure that Engineer has an approved Manufacturer's Certification or waiver prior to items being delivered to the project site.

I. By submitting an application for payment, based in whole or in part on furnishing equipment or materials, Contractor certifies that such equipment and materials, to Contractor's knowledge, are compliant with BABAA requirements.

SC-7.09B.

Add the following new paragraph immediately after Paragraph 7.09A of the General Conditions to read as follows:

B. The Contractor shall make himself aware of all laws applicable to the Work pertaining to the licensing of specific trades and securing of related permits. The Contractor shall be solely responsible to assure that he and all his proposed Subcontractors are in compliance with such laws at the time of submission of Contractor's Bid. The Contractor shall submit to the Owner any documentation necessary or required to verify such compliance.

SC-7.10B.

Add the following new Paragraph 7.10B to the General Conditions to read as follows:

B. This Project is exempt from sales tax on products permanently incorporated into the Work. Sales tax exemption certificate shall be available from the Owner. Contractor shall attach the tax exemption certificate to invoices for materials incorporated in the Work. Upon completion of the Work, Contractor shall file with Owner a notarized statement that all purchases were entitled to be exempt. Contractor shall pay legally assessed penalties, including any unpaid sales taxes, for improper use of Owner's tax exemption status.

SC-7.11D.

Add the following new paragraph immediately after Paragraph 7.11C of the General Conditions to read as follows:

D. During execution of the Work, the Contractor and each of his Subcontractors and any firms with employees performing portions of the Work under these Contract Documents agree not to discriminate against any employee or applicant for employment because of race, color, religion, age, sex, or national origin. The Contractor shall ensure that applicants are employed, and that employees are treated during employment without regard to race, color, religion, age, sex, or national origin. This includes, but is not limited to, the following: employment, upgrading, demotion or transfer, recruitment or recruiting advertisement, lay-off or termination, rate of pay or other form of compensation, and selection for training, including apprenticeship.

SC-7.12A.

Add the following new sentence at the end of Paragraph 7.12A of the General Conditions:

Should the Owner find that the Contractor is not satisfying the requirements of this paragraph, the Owner may withhold all or portions of progress payments until these requirements are complied with by the Contractor to the satisfaction of the Owner.

SC-7.13

Add the following new paragraph 7.13.E.1 of the General Conditions as follows:

Contractor is required to provide proper PPE and training for the work activities on the project including, but not limited to, for lead service line removal and replacement as recommended by the National Institute for Occupational Safety and Health (NIOSH) <https://www.cdc.gov/niosh/docs/wp-solutions/2023-141/default.html>.

SC-7.15A.

Delete the last sentence in Paragraph 7.15A. of the General Conditions in its entirety and replace with the following:

If Engineer determines that the incident giving rise to the emergency action was not the responsibility of the Contractor and that a change in the Contract Document is required because of the action taken by the Contractor in response to such an emergency, a Work Change Directive or Change Order will be issued.

SC-7.16D.1.

Add the following new sentence at the end of paragraph 7.16.D.1 of the General Conditions to read as follows:

Approval of Shop Drawings for equipment requiring Efficiency Guarantee Bonds will be withheld until the receipt of such Bonds.

SC-7.17A.

Add the following new paragraph immediately after Paragraph 7.17A. of the General Conditions which is to read as follow:

1. The Contractor guarantees that the Work and Services to be performed under the Contract, and all workmanship, materials and equipment performed, furnished, used or installed in the construction of the same shall be free from defects and flaws, and shall be performed and furnished in strict accordance with the Drawings, Specifications, and other Contract Documents, that the strength of all parts of all manufactured equipment shall be adequate and as specified and that the performance test requirements of the Contract shall be fulfilled. This guarantee shall be for a period of one year from and after the date of substantial completion. If part of the Work is accepted in accordance with Paragraph 15.04 of the General Conditions, the guarantee for that part of the Work shall be for a period of one year from the date fixed for such acceptance.
2. If at any time within the said period of guarantee any part of the Work requires repairing, correction or replacement, the Owner may notify the Contractor in writing to make the required repairs, correction or replacements. If the Contractor neglects to commence making such repairs, corrections or replacements to the satisfaction of the Owner within seven (7) days from the date of receipt of such notice, or having commenced fails to prosecute such Work with diligence, the Owner may employ other persons to make said repairs, correction or replacements, and charge the costs, including compensation for additional professional services, to the Contractor.
3. The Contractor's guarantee under Paragraph 7.17A, is in addition to the Contractor's express or implied warranties under this Contract and State law and in no way diminish any other rights that the Owner may have against the Contractor.

SC-7.17F.

Add the following new paragraph immediately after Paragraph 7.17E. of the General Conditions which is to read as follows:

F. Manufacturer's Guaranty/Warranty

1. The Contractor shall obtain the following guaranty/warranty from the manufacturer of all major pieces of equipment furnished and installed on this Project. Such guaranty/warranty shall be for the benefit of Owner and be furnished in writing by the manufacturer. The Contractor's and manufacturer's obligations under this provision are in addition to other express or implied warranties under the Contract Documents and under the law and in no way diminish any other right that the Owner may have against the Contractor or manufacturer for faulty material, equipment or work. The warranty period shall not be interpreted as a limitation on the time in which the Owner can enforce such other duties, obligations, rights, or remedies.
2. The manufacturer warrants and guarantees for a period of one year from the date of Substantial Completion, or such longer period that may be specified in the Contract Documents, that all materials and equipment furnished and installed shall be free from flaws, defects in material and workmanship and shall be in conformance with the Contract Documents.

SC-7.18A.

Delete Paragraph 7.18A of the General Conditions in its entirety and replace with the following:

A. To the fullest extent permitted by Laws and Regulations, and in addition to any other obligations of Contractor under the Contract or otherwise, Contractor shall defend, indemnify and hold harmless Owner, Engineer and the officers, directors, members, partners, employees, agents, consultants and subcontractors of each and any of them from and against all claims, costs, losses and damages (including but not limited to all reasonable fees and charges of engineers, architects, attorneys and other professionals and all court or arbitration or other dispute resolution costs) arising out of or relating to the performance of the Work, provided that any such claim, cost or loss or damage:

1. is attributable to bodily injury, sickness, disease or death or to injury to or destruction of tangible property (other than the Work itself), including the loss of use resulting therefrom; and
2. is caused in whole or in part by any act or omission of Contractor, any Subcontractor, any Supplier, or any individual or entity directly or indirectly employed by any of them to perform any of the Work or anyone for whose acts any of them may be liable, regardless of whether or not caused in part by any negligence or omission of an individual or entity indemnified hereunder or whether liability is imposed upon such indemnified party by Laws and Regulations regardless of the negligence of any such indemnified party unless caused by the sole negligence of a party indemnified hereunder. If through the omissions or acts of neglect on the part of Contractor, any other contractor or any Subcontractor shall suffer loss or damage on the Work, Contractor shall settle with such other contractor or Subcontractor by agreement or arbitration if such other contractor or Subcontractor will so settle. If such other contractor or Subcontractor shall assert any claim against Owner and/or Engineer, or the officers, directors, members, partners, employees, agents, consultants and subcontractors of each on account of any damage alleged to have been sustained, Owner shall notify Contractor, who shall defend, indemnify and save harmless Owner, Engineer, and the officers, directors, members, partners, employees, agents, consultants and subcontractors of each against any such claims.

SC-7.18C.

Add the following new paragraph immediately after Paragraph 7.18B of the General Conditions:

C. The indemnification obligations of the Contractor under paragraphs 7.18 and Article 12 shall include defending all those indemnified, including, but not limited to, payment of all professional court, mediation, arbitration, and attorney costs which may be incurred as a result of such defense.

ARTICLE 8. OTHER WORK AT THE SITE

SC-8.02A.

Delete the words “Supplementary Conditions” and replace them with the words “Contract Documents”.

SC-8.02B.

Delete the words “Supplementary Conditions” and replace them with the words “Contract Documents”.

SC-8.03A.

Delete paragraph 8.03A of the General Conditions in its entirety and replace with the following.

A. If, in the course of performing other work at or adjacent to the Site for Owner, the Owner’s employees, any other contractor working for Owner, or any utility owner for whom the Owner is responsible causes damage to the Work or to the property of Contractor or its Subcontractors, or delays, disrupts, interferes with, or increases the scope or cost of the performance of the Work, through actions or inaction, then Contractor shall not institute any action, legal or equitable, against Owner, Engineer, Engineer’s Consultants or the Construction Coordinator or permit any action against any of them to be maintained and continued in its name or for its benefit in any court or before any arbiter which seeks to impose liability on or to recover damages from Owner, Engineer, Engineer’s Consultants or the Construction Coordinator on account of any such damage or claim. If Contractor is delayed at any time in performing or furnishing Work by any act or neglect of a separate contractor and Owner and Contractor are unable to agree as to the extent of any adjustment in Contract Times attributable thereto, Contractor may make a claim for an extension of times in accordance with Article 12. An extension of the Contract Times shall be Contractor’s exclusive remedy with respect to Owner, Engineer, Engineer’s Consultants and Construction Coordinator for any delay, disruption, interference or hindrance caused by any separate contractor. This paragraph does not prevent recovery from Owner, Engineer, Engineer’s Consultant or Construction Coordinator for activities that are their respective responsibilities.

SC-8.03C.

Delete Paragraph 8.03C of the General Conditions in its entirety and replace with the following.

C. If Contractor damages, delays, disrupts, or interferes with the work of any other contractor, or any utility owner performing other work at or adjacent to the Site, through Contractor’s failure to take reasonable and customary measures to avoid such impacts, or if any claim arising out of Contractor’s actions, inactions, or negligence in performance of the Work at or adjacent to the Site is made by any such other contractor or utility owner against Contractor, Owner, or Engineer, Engineer’s Consultants, the Construction Coordinator or any person then Contractor shall promptly attempt to settle the claim as to all parties through negotiations with such other contractor or utility owner, or otherwise resolve the claim by arbitration or other dispute resolution proceeding or at law, Contractor shall, to the fullest extent

permitted by Laws and Regulations defend, indemnify and hold Owner, Engineer, Engineer's Consultants and the Construction Coordinator harmless from and against all claims, damages, losses and expenses (including, but not limited to, fees of engineers, architects, attorneys and other professionals, and court and arbitration or mediation costs) arising directly, indirectly or consequentially out of any action, legal or equitable, brought by any separate contractor against Owner, Engineer, Engineer's Consultants or the Construction Coordinator to the extent based on a claim arising out of Contractor's performance of the Work.

SC-8.03D.

Add the following new paragraph immediately after Paragraph 8.03C of the General Conditions which is to read as follows:

D. If Contractor is delayed at any time in performing or furnishing Work by any act or neglect of a separate contractor, and Owner and Contractor are unable to agree as the adjustment in Contract Time attributable thereto, Contractor may make a Claim for an extension of time in accordance with Article 12. An extension of the Contract Time shall be Contractor's sole and exclusive remedy with respect to Owner, Engineer, Engineer's Consultants, and construction coordinator for any delay, disruption, interference, or hindrance caused by any separate contractor.

ARTICLE 9. OWNER'S RESPONSIBILITIES

SC-9.02A.

Delete Paragraph 9.02.A of the General Conditions in its entirety and replace it with the following:

A. In case of termination of the employment of the ENGINEER, the OWNER may, at his option, appoint another Engineer or the OWNER may assume the responsibilities and authority of the ENGINEER defined in the Contract Documents.

SC-9.04

Delete the words "Pay When Due" in the title of this paragraph and replace them with the word "Payment".

SC-9.08A.

Delete Paragraph 9.08.A of the General Conditions in its entirety and replace it with the following:

A. OWNER'S responsibility in respect to certain inspections, tests, and approvals is set forth in paragraph 14.02.B and as may be supplemented by the General Requirements.

SC-9.11A.

Delete Paragraph 9.11A of the General Conditions in its entirety.

ARTICLE 10 - ENGINEER'S STATUS DURING CONSTRUCTION

SC-10.03 Resident Project Representative

SC-10.03C.

Add the following new paragraphs immediately after paragraph 10.03B of the General Conditions which are to read as follows:

C. The Resident Project Representative (RPR) will be Engineer's representative at the Site, will act as directed by and under the supervision of Engineer, and will confer with Engineer regarding RPR's actions.

1. General: RPR's dealings in matters pertaining to the Work in general shall be with Engineer and Contractor. RPR's dealings with Subcontractors shall only be through or with the full knowledge and approval of Contractor. RPR shall generally communicate with Owner only with the knowledge of and under the direction of Engineer.

2. Schedules: Review the progress schedule, schedule of Shop Drawing and Sample submittals, and Schedule of Values prepared by Contractor and consult with Engineer concerning acceptability.

3. Conferences and Meetings: Attend meetings with Contractor, such as preconstruction conferences, progress meetings, job conferences, and other Project-related meetings, and prepare and circulate copies of minutes thereof.

4. Liaison:

- a. Serve as Engineer's liaison with Contractor. Working principally through Contractor's authorized representative or designee, assist in providing information regarding the provisions and intent of the Contract Documents.
- b. Assist Engineer in serving as Owner's liaison with Contractor when Contractor's operations affect Owner's on-Site operations.
- c. Assist in obtaining from Owner additional details or information, when required for proper execution of the Work.

5. Interpretation of Contract Documents: Report to Engineer when clarifications and interpretations of the Contract Documents are needed and transmit to Contractor clarifications and interpretations as issued by Engineer.

6. Shop Drawings and Samples:

- a. Record date of receipt of Samples and Contractor-approved Shop Drawings.
- b. Receive Samples which are furnished at the Site by Contractor, and notify Engineer of availability of Samples for examination.

- c. Advise Engineer and Contractor of the commencement of any portion of the Work requiring a Shop Drawing or Sample submittal for which RPR believes that the submittal has not been approved by Engineer.
 - d. Engineer approval of shop drawings or samples shall include review of BABAA documentation.
7. Modifications: Consider and evaluate Contractor's suggestions for modifications in Drawings or Specifications and report such suggestions, together with RPR's recommendations, if any, to Engineer. Transmit to Contractor in writing decisions as issued by Engineer.
8. Review of Work and Rejection of Defective Work:
 - a. Conduct on-Site observations of Contractor's work in progress to assist Engineer in determining if the Work is in general proceeding in accordance with the Contract Documents.
 - b. Report to Engineer whenever RPR believes that any part of Contractor's work in progress is defective, will not produce a completed Project that conforms generally to the Contract Documents, or will imperil the integrity of the design concept of the completed Project as a functioning whole as indicated in the Contract Documents, or has been damaged, or does not meet the requirements of any inspection, test or approval required to be made; and advise Engineer of that part of work in progress that RPR believes should be corrected or rejected or should be uncovered for observation, or requires special testing, inspection or approval.
9. Inspections, Tests, and System Start-ups:
 - a. Verify that tests, equipment, and systems start-ups and operating and maintenance training are conducted in the presence of appropriate Owner's personnel, and that Contractor maintains adequate records thereof.
 - b. Observe, record, and report to Engineer appropriate details relative to the test procedures and systems start-ups.
10. Records:
 - a. Prepare a daily report or keep a diary or log book, recording Contractor's hours on the Site, Subcontractors present at the Site, weather conditions, data relative to questions of Change Orders, Field Orders, Work Change Directives, or changed conditions, Site visitors, deliveries of equipment or materials, daily activities, decisions, observations in general, and specific observations in more detail as in the case of observing test procedures; and send copies to Engineer.
 - b. Record names, addresses, fax numbers, e-mail addresses, web site locations, and telephone numbers of all Contractors, Subcontractors, and major Suppliers of materials and equipment.
 - c. Maintain records for use in preparing Project documentation.
11. Reports:
 - a. Furnish to Engineer periodic reports as required of progress of the Work and of Contractor's compliance with the Progress Schedule and schedule of Shop Drawing and Sample submittals.

- b. Draft and recommend to Engineer proposed Change Orders, Work Change Directives, and Field Orders. Obtain backup material from Contractor.
- c. Immediately notify Engineer of the occurrence of any Site accidents, emergencies, acts of God endangering the Work, force majeure or delay events, damage to property by fire or other causes, or the discovery of any Constituent of Concern or Hazardous Environmental Condition.

12. Payment Requests: Review applications for payment with Contractor for compliance with the established procedure for their submission and forward with recommendations to Engineer, noting particularly the relationship of the payment requested to the Schedule of Values, Work completed, and materials and equipment delivered at the Site but not incorporated in the Work.

13. Certificates, Operation and Maintenance Manuals: During the course of the Work, verify that materials and equipment certificates, operation and maintenance manuals and other data required by the Contract Documents to be assembled and furnished by Contractor are applicable to the items actually installed and in accordance with the Contract Documents, and have these documents delivered to Engineer for review and forwarding to Owner prior to payment for that part of the Work.

14. Completion:

- a. Participate in Engineer's visits to the Site to determine Substantial Completion, assist in the determination of Substantial Completion and the preparation of a punch list of items to be completed or corrected.
- b. Participate in Engineer's final visit to the Site to determine completion of the Work, in the company of Owner and Contractor, and prepare a final punch list of items to be completed and deficiencies to be remedied.
- c. Observe whether all items on the final list have been completed or corrected and make recommendations to Engineer concerning acceptance and issuance of the notice of acceptability of the work.

D. The RPR shall not:

- 1. Authorize any deviation from the Contract Documents or substitution of materials or equipment (including "or-equal" items).
- 2. Exceed limitations of Engineer's authority as set forth in the Contract Documents.
- 3. Undertake any of the responsibilities of Contractor, Subcontractors, or Suppliers.
- 4. Advise on, issue directions relative to, or assume control over any aspect of the means, methods, techniques, sequences or procedures of Contractor's work.
- 5. Advise on, issue directions regarding, or assume control over security or safety practices, precautions, and programs in connection with the activities or operations of Owner or Contractor.
- 6. Participate in specialized field or laboratory tests or inspections conducted off-site by others except as specifically authorized by Engineer.
- 7. Accept Shop Drawing or Sample submittals from anyone other than Contractor.

8. Authorize Owner to occupy the Project in whole or in part.
SC-10.03C

Add the following new paragraph immediately after Paragraph 10.03B of the General Conditions which is to read as follows:

C. On this Project, by agreement with the Owner, Engineer will not furnish a Resident Project Representative to represent Engineer at the Site or assist Engineer in observing the progress and quality of the Work.

SC-10.05A.

Delete Paragraph 10.05A of the General Conditions in its entirety and replace it with the following:

A. Engineer will determine the actual quantities and classifications of Unit Price Work performed by Contractor. Engineer will review with Owner and Contractor the Engineer's preliminary determinations on such matters before rendering a written decision thereon (by recommendation of an Application for Payment or otherwise). Engineer's written decision thereon will be final and binding (except as modified by Engineer to reflect changed factual conditions or more accurate data) upon Contractor, subject to the provisions of paragraph 13.03.

SC-10.06B

Add the following Paragraph 10.06B immediately after Paragraph 10.07A of the General Conditions:

B. The rendering of a decision by Engineer pursuant to this Paragraph 10.07 with respect to any such Claim, dispute, or other matter (except any which have been waived by the making or acceptance of final payment as provided in paragraph 15.06) will be a condition precedent to any exercise by Contractor of such rights or remedies as Contractor may otherwise have under the Contract Documents or by Laws or Regulations in respect of any such Claim, dispute, or other matter.

ARTICLE 11 - CHANGES TO THE CONTRACT

SC-11.02C

Add the following Paragraph 11.02C immediately after Paragraph 11.02B of the General Conditions:

C. For any change orders, Contractor shall provide BABAA documentation for any new products or materials required by the change.

SC-11.07B.2

Delete Paragraph 11.07B.2. of the General Conditions in its entirety.

SC-11.07C.1.

Delete Paragraph 11.07C.1 of the General Conditions in its entirety.

SC-11.07C.2.

Delete "15 percent" in the second line of Paragraph 11.07C.2.a of the General Conditions and replace with "20 percent".

SC-11.07C.2.b.

In Paragraph 11.07C.2.b, before the semicolon add the following words "based on subcontractor's Cost of the Work";

Delete "5 percent" in Paragraph 11.07C.2.b of the General Conditions and replace with "7-1/2 percent."

Delete "15 percent" in the third line of Paragraph 11.07C.2.c, of the General Conditions and replace with "20 percent" and delete "5 percent" in the seventh line and replace with "7-1/2 percent."

ARTICLE 13 - COST OF THE WORK; ALLOWANCES; UNIT PRICE WORK

SC-13.01B.1.

Delete the second sentence in Paragraph 13.01B.1. of the General Conditions in its entirety and replace with the following:

Such employees shall include foremen at the site.

SC-13.03E.

Delete Paragraph 13.03E. of the General Conditions in its entirety and replace with the following:

E. The unit price of an item of Unit Price Work shall be subject to re-evaluation and adjustment under the following conditions:

1. if the total cost of a particular item of Unit Price Work amounts to 5 percent or more of the Contract Price and the variation in the quantity of that particular item of Unit Price Work performed by Contractor differs by more than 15 percent above the estimated quantity of such item indicated in the Agreement; and
2. if there is no corresponding adjustment with respect to any other item of Work; and
3. if Contractor believes that Contractor has incurred additional expense as a result thereof; or if Owner believes that the quantity variation entitles Owner to an adjustment in the unit price, either Owner or Contractor may make a claim for an adjustment in the Unit Price for that quantity by which the actual quantity exceeds 115% of the estimated quantity in accordance with Article 12 if the parties are unable to agree as to the effect of any such variations in the quantity of Unit Price Work performed.

ARTICLE 14 - TESTS AND INSPECTIONS; CORRECTION, REMOVAL OR ACCEPTANCE OF DEFECTIVE WORK

SC-14.06B.

Add the following new paragraph immediately after Paragraph 14.06A. of the General Conditions to read as follows:

B. If Owner stops Work under Paragraph 14.06A. Contractor shall not be entitled to any extension of Contract Time or increase in Contract Price.

ARTICLE 15 - PAYMENTS TO CONTRACTOR; SET-OFFS; COMPLETION; CORRECTION PERIOD

SC-15.01B.1.

In the first sentence of Paragraph 15.01.B.1 of the General Conditions delete the number "20" and replace with the number "10".

SC-15.01B.4.

Delete the word "Agreement" and replace it with "Contract Documents" in Paragraph SC-15.01B.4 of the General Conditions.

SC-15.01B.5.

Add the following new paragraph immediately after Paragraph 15.01B.4 of the General Conditions which is to read as follows:

5. Contractor shall furnish evidence that payment received on the basis of materials and equipment not incorporated and suitably stored, has in fact been paid to the respective supplier(s) within sixty (60) days of payment by Owner. Failure to provide such evidence of payment may result in the withdrawal of previous approval(s) and removal of the cost of related materials and equipment from the next submitted Application for Payment.

SC-15.01B.6.

Add the following three new paragraphs immediately after Paragraph 15.01B.4 of the General Conditions which are to read as follows:

6. With each Application for Payment, the CONTRACTOR shall submit certified payrolls for all his employees that performed work on the project for the payment application period and for all Subcontractors' employees to demonstrate compliance with Rhode Island General Laws Chapter 37-13-1 through 37-13-7 and State of Rhode Island Department of Labor prevailing wage requirements. Certified payrolls shall be prepared and submitted on the "Statement of Compliance" forms as prescribed and in accordance with the State of Rhode Island Department of Labor.

7. The form used for preparation and submission of Applications for Payments shall be AIA Form G702 and G703, which shall be provided by the Contractor, unless another form is approved by the OWNER prior to the submission of the first Application for Payment.

8. Applications for Payments shall be submitted monthly by Contractor.

SC-15.01.C.1.

Delete the words "within 10 days" from the first sentence of Paragraph 15.01.C.1 of the General Conditions.

SC-15.01D.1.

In paragraph 15.01D.1. of the General Conditions delete the word "Ten days".

SC-15.01D.1.

Add the following new paragraphs immediately after Paragraph 15.01D.1. of the General Conditions which are to read as follows:

2. Should Contractor neglect to pay any undisputed claims, made in writing to Owner within thirty days after completion of the Work, but continuing unsatisfied for a period of ninety days, Owner may pay such claim and deduct the amount thereof from the balance due Contractor. Owner may also, with the written consent of Contractor, use any monies retained, due, or to become due under this Contract for the purpose of paying for both labor and materials for the Work, for which claims have not been filed.
3. Security is provided both by the Payment Bond and the power of Owner to retain any monies for claims, but payment by one shall in no way impair or discharge the liability of the other.
4. All monies paid by Owner in settlement of liens, with the costs and expenses incurred by Owner in connection therewith, shall be charged to Contractor, shall bear interest at the rate of three percentage points above the rediscount rate then charged by the Federal Reserve Bank, and shall be deducted from the next payment due Contractor under the terms of this Contract.

SC-15.01E.1.m

Add the following new paragraph immediately after Paragraph 15.01.E.1 of the General Conditions which is to read as follows:

- m. Invoices submitted by Contractor for work that exceeds 90 days, following completion of said work. Time is of the essence for Contractor to promptly submit invoices to Owner for review and processing and Owner reserves the right to withhold or refuse payment for invoices for work completed over 90 days prior.

SC-15.01E.2.

Delete the word "promptly" from both the first and second sentences of Paragraph 15.01E.2 of the General Conditions.

SC-15.01E.3.

Delete Paragraph 15.01.E.3 of the General Conditions in its entirety.

SC-15.02

Add the following new paragraphs immediately after Paragraph 15.02A of the General Conditions which are to read as follows:

- B. The Contractor shall immediately satisfy any Lien or encumbrance which, because of any act or default of the Contractor, is filed against the premises of the project, and shall indemnify and save the Owner harmless against all resulting loss and expense, including attorney's fees. In addition, monies due under this Contract, as may be considered necessary by the Owner, may be retained by the Owner until all such suits, claims for damages, or expense, etc. shall have been settled and paid.

C. No materials or supplies for the Work shall be purchased by Contractor or Subcontractor subject to any chattel mortgage or under a conditional sale contract or other agreement by which an interest is retained by the seller. Contractor warrants that Contractor has good title to all materials and supplies used by Contractor in the Work, free from all liens, claims or encumbrances.

D. Contractor shall defend, indemnify and save Owner and Engineer harmless from all claims growing out of the lawful demands of Subcontractors, laborers, workmen, mechanics, materialmen, and furnishers of machinery and parts thereof, equipment, power tools, and all supplies, including commissary, incurred in the furtherance of the performance of this Contract. Contractor shall at Owner's request, furnish satisfactory evidence that all obligations of the nature hereinabove designated have been paid, discharged, or waived. If Contractor fails to do so, then Owner may, after having served written notice on the said Contractor either pay unpaid bills, of which Owner has written notice, direct, or withhold from the Contractor's unpaid compensation a sum of money deemed reasonably sufficient to pay any and all such lawful claims until satisfactory evidence is furnished that all liabilities have been fully discharged whereupon payment to Contractor shall be resumed, in accordance with the terms of this Contract, but in no event shall the provisions of this sentence be construed to impose any obligations upon Owner to either Contractor or Contractor's Surety. In paying any unpaid bills of the Contractor, Owner shall be deemed the agent of Contractor and any payment so made by Owner shall be considered as payment made under the Contract by Owner to Contractor and Owner shall not be liable to Contractor for any such payment made in good faith.

SC-15.03.F.

Delete Paragraph 15.03.F of the General Conditions in its entirety.

SC-15.05.B.

Add the following new paragraph immediately after Paragraph 15.05.A of the General Conditions which is to read as follows:

B. Upon completion of the Work, the Contractor shall deliver to the Owner all required certificates of testing and inspection.

SC-15.06.A.4.

Add the following new paragraph immediately after Paragraph 15.06.A.3 of the General Conditions which is to read as follows:

4. Prior to preparation of the punch list by the Engineer, the Contractor and his Subcontractors shall submit their respective certificates of contract document compliance with Contractor's written notice that the Work is complete. After Final Completion, including completion of all punch list items, the Owner will consider processing of the final Application for Payment only after receipt of: 1) warranties and guaranties; 2) operations and maintenance manuals; 3) record (as-built) drawings; 4) Contractor's affidavits; 5) consent of surety; 6) extra materials and samples required for Owner; 7) lien waivers and releases; and 8) occupancy permit, if required. Completion of the Project shall be construed to include accomplishment and acceptance of punch list items.

SC-15.06B.

Delete Paragraph 15.06B of the General Conditions in its entirety and replace with the following:

Engineer's Review of Final Application and Recommendation of Payment: If, on the basis of Engineer's observation of the Work during construction and final inspection, and Engineer's review of the final Application for Payment and accompanying documentation - all as required by the Contract Documents, Engineer is satisfied that the Work has been completed and Contractor's other obligations under the Contract Documents have been fulfilled, Engineer will indicate in writing Engineer's recommendation of payment and present the Application to Owner for payment. Thereupon Engineer will give written notice to Owner and Contractor that the Work is acceptable subject to the provisions of paragraph 15.07. Otherwise, Engineer will return the Application to Contractor, indicating in writing the reasons for refusing to recommend final payment, in which case Contractor shall make the necessary corrections and resubmit the Application. If the Application and accompanying documentation are appropriate as to form and substance, Owner shall in accordance with the applicable laws and regulations, pay Contractor the amount recommended by Engineer.

SC-15.06E.

Delete the word "Thirty" and replace it with "Ninety" in Paragraph 15.06E of the General Conditions.

SC-15.06F.

Add the following new paragraph immediately after Paragraph 15.06E. of the General Conditions which is to read as follows:

F. Final payment will be reduced by the amount of excessive costs of plant inspection of pipe. Excessive costs are defined as the inspection costs incurred by Owner for that amount of pipe which exceeds 125 percent of the aggregate length of each type installed.

ARTICLE 16 - SUSPENSION OF WORK AND TERMINATION

SC-16.02A.5.

Add the following new paragraph immediately after Paragraph 16.02.A.4 of the General Conditions which is to read as follows:

5. If Contractor abandons the Work, or sublets this Contract or any part thereof, without the previous written consent of Owner, or if the Contract or any claim thereunder shall be assigned by Contractor otherwise than as herein specified.

SC-16.04

Delete Paragraph 16.04 of the General Conditions in its entirety.

ARTICLE 17 - FINAL RESOLUTION OF DISPUTES

SC-17.01

Delete Paragraph 17.01 of the General Conditions in its entirety and replace it with the following:

17.01 *Conditions*

A. As a precondition to the implementation of action under this Article 17, the claim, when applicable, must be made and a decision rendered in accordance with the provisions of Paragraphs 10.06 and 12.01 as they apply to each party under the Contract Documents.

B. By entering into the Contract, the Owner and Contractor agree that time is of the essence in resolving any disputes and that failure to make any claim for damages or delays in accordance with the requirements and time constraints set forth in the Contract Documents shall nullify the claim and the claimant shall waive his rights to further action provided by the Contract or laws and waive its right to litigate the claim.

C. The location of all meetings for negotiations and mediation shall be the Owner's offices, with the actual physical location to be determined by the Owner.

D. It is understood and accepted by all parties that any agreement reached as a result of this Article resolving a dispute will require the final approval of the City of Providence Board of Contract and Supply before the agreement can be finalized and executed.

SC-17.02

Add the following new paragraph immediately after Paragraph 17.01 of the General Conditions which is to read as follows:

17.02 Negotiations

A. If either the Owner or Contractor chooses to appeal the Engineer's decision rendered under Article 12 as applicable, or for unresolved claims not requiring such a decision, the Owner or Contractor must, within 15 days of the date of the Engineer's decision, deliver to the Engineer and to the opposing party a written notice requesting that the negotiation procedures of this Article be initiated. Within 15 days after the initial written notice, the opposing party must submit its written response to the Engineer and the other party. The initial notice and the response must include a statement of each party's position on the claim, a summary of the party's arguments supporting its position, and the name and title of the Principal who will represent the party and the names and titles of each person who will be attending the negotiations. The Principals representing each party must be at a higher management level than the persons responsible for administering the Work and have authority to make decisions that settle the claim, subject to the provisions of paragraph 17.01.D.

B. The initial negotiations meeting will be scheduled by the Engineer and must be held within 30 days of the date of the initial written notice. Within 10 days of the date of such notice to the Engineer and opposing party, the Engineer will contact each party and arrange and schedule a mutually agreeable time and date to meet. The Engineer will confirm in writing with each party the date, time and location of the meeting. All parties to the claim must make themselves available to a date within this period or the Engineer will establish a mandatory date and time for the meeting which both parties must attend. Failure to attend this meeting will result in the forfeiture of the claim by the party not attending and in that party's waiver of any rights to further pursue or litigate the claim.

C. The parties shall meet at the initially scheduled meeting and additional meetings arranged thereafter as necessary to attempt to resolve the claim. The parties shall use their best efforts to resolve the claim and shall consult and negotiate with each other in good faith. Recognizing their mutual interests, the parties shall attempt to reach a just and equitable resolution satisfactory to both parties. The Engineer shall attend the negotiation meetings if requested by either party for the sole purpose of providing information pertinent to resolving the claim.

D. Conduct and statements made pursuant to this paragraph during the negotiation process, both written and verbal, shall be considered to have been made during compromised negotiations and shall not be admissible in any further litigation pursuant to Rule 408 of the Federal Rules of Evidence and State of Rhode Island counterparts and any similarly applicable rules.

E. Each party involved in the negotiation process shall be responsible for and pay its own costs incurred, including all administrative costs, costs of witnesses produced by the party, and legal costs and fees, and shall not pursue nor be entitled to reimbursement in any way from the opposing party.

F. If the parties do not reach a mutually acceptable resolution within 30 days of the initial meeting, either party may provide written notice to the opposing party terminating the negotiation process after that time.

SC-17.03

Add the following new paragraph immediately after new Paragraph 17.02 of the General Conditions which is to read as follows:

17.03 Non-Binding Mediation

A. Owner and Contractor agree that they shall submit any and all claims, counterclaims, disputes, or other matters in question between them arising out of or relating to the Contract Documents or the breach thereof that remain unsettled after negotiation to non-binding mediation prior to either of them initiating against the other a demand for arbitration under the Public Works Arbitration Act, if applicable, or litigation in Superior Court, as provided in Paragraph 17.04. Completion of the negotiation process of Paragraph 17.02 shall be a precondition to requesting non-binding mediation.

B. If the Owner and Contractor cannot reach a mutually agreeable resolution to the claim through negotiation as provided for in paragraph 17.02, either party may choose to deliver to the opposing party a request for non-binding mediation. The request for non-binding mediation must be delivered to the opposing party within 10 days of the date of the written notice terminating the negotiation process as provided under paragraph 17.02.F.

C. Representatives of each party authorized to make the decisions required of the non-binding mediation process shall meet within 15 days of the date of the request for non-binding mediation. Each party to the claim must provide the other with at least five dates within that period that they are available to meet and a meeting arranged on a mutually agreeable date. The failure of either party to attend a scheduled meeting will result in the forfeiture of the claim by that party and that party's waiver of any rights to further pursue or litigate the claim.

D. The parties shall meet in good faith to discuss the issues surrounding the non-binding mediation process and to negotiate to choose an outside party as a mediator for the proceedings. If after 15 days from the initial meeting of the parties they are unable to agree upon a mediator, each of the parties shall select a mediator of its own to represent them, and the two mediators selected shall meet with each other within 10 days of their selection and negotiate and select a single mediator (herein after referred to as the "mediator") for the proceedings.

E. The mediator shall establish the rules and procedures used during the mediation proceedings. All parties to the proceedings shall abide by the rules established by the mediator.

F. Conduct and statements made pursuant to this paragraph during the mediation process, both written and verbal, shall be considered to have been made during compromised negotiations and shall not be admissible in any further litigation pursuant to Rule 408 of the Federal Rules of Evidence and State of Rhode Island counterparts and any similarly applicable rules.

G. Each party involved in the mediation process shall be responsible for and pay its own costs incurred to present its case, including all administrative costs, costs of witnesses produced by the party, and legal costs and fees, and shall not pursue or be entitled to reimbursement in any way from the opposing party. The parties will equally divide and pay all costs for the services of the mediator and any witnesses or experts (having no direct or indirect connection to or interests in either party's behalf) produced at the direct request of the mediator, including administrative, travel and incidental expenses of both the mediator and such witnesses. If the parties were unable to agree on a single mediator and had to choose separate mediators to select the final mediator, each party shall be responsible for and pay all costs and expenses of the mediator that it chose, in addition to equally dividing the costs of the final mediator as described above.

H. If the parties do not reach a mutually acceptable resolution within 90 days of the initial meeting of the parties, either party may provide written notice to the opposing party terminating the mediation proceedings after that time.

SC-17.04.

Add the following new paragraph immediately after new Paragraph 17.03 of the General Conditions which is to read as follows:

17.04 Litigation and Public Works Arbitration

A. If the parties fail to reach a mutually acceptable agreement as a result of the non-binding mediation proceedings described in paragraph 17.03, the exclusive remedy remaining to the parties, unless the Work is subject to the provisions of the Public Works Arbitration Act of the State of Rhode Island General Laws, will be to file suit in Superior Court for Providence County, Rhode Island before the business calendar in that court. The Owner and Contractor agree to waive any claims that venue is inappropriate in this court.

B. If the parties fail to reach a mutually acceptable agreement as a result of the non-binding mediation proceedings described in Paragraph 17.03 and the Public Works Arbitration Act of Chapter 37-16 of the State of Rhode Island General Laws applies to the Work as determined by the contract types listed by Section 37-16-2 of the Chapter, then the Chapter shall apply and the context of Paragraph 37-16-2(b)(2) shall be in effect as if included in these Supplemental Conditions.

ARTICLE 18 - MISCELLANEOUS

SC-18.10.

Add the following new paragraphs immediately after Paragraph 18.10 of the General Conditions which are to read as follows:

18.11 Addresses

A. Both the address given in the Bid Form upon which this Agreement is founded, and Contractor's office at or near the site of the Work are hereby designated as places to either of which notices, letters,

and other communications to Contractor shall be certified, mailed, or delivered. The delivering at the above-named place, or depositing in a postpaid wrapper directed to the first-named place, in any post office box regularly maintained by the post office department, of any notice, letter or other communication to Contractor shall be deemed sufficient service thereof upon Contractor; and the date of said service shall be the date of such delivery or mailing. The first-named address may be changed at any time by an instrument in writing, executed and acknowledged by Contractor, and delivered to Owner and Engineer. Nothing herein contained shall be deemed to preclude or render inoperative the service of any notice, letter, or other communication upon Contractor personally.

18.12 Wage Rates

A. The requirements and provisions of all applicable laws and any amendments thereof or additions thereto as to the employment of labor, and to the schedule of minimum wage rates established in compliance with laws shall be a part of these Contract Documents. Copies of the wage schedules are included in PART II of these Supplementary Conditions. If, after the Notice of Award, it becomes necessary to employ any person in a trade or occupation not classified in the wage determinations, such person shall be paid at not less than such rates as shall be determined by the officials administering the laws mentioned above. Such approved minimum rate shall be retroactive to the time of the initial employment of such person in such trade or occupation. Contractor shall notify Owner of Contractor's intention to employ persons in trades or occupations not classified in sufficient time for Owner to obtain approved rates for such trades or occupations.

B. The schedules of wages referred to above are minimum rates only, and Owner will not consider any claims for additional compensation made by Contractor because of payment by Contractor of any wage rate in excess of the applicable rate contained in these Contract Documents. All disputes between Contractor and employees of Contractor in regard to the payment of wages in excess of these specified in the schedules shall be resolved by Contractor.

C. The said schedules of wages shall continue to be the minimum rates to be paid during the life of this Agreement and a legible copy of said schedules shall be kept posted in a conspicuous place at the site of the work.

D. Both Federal and State schedules of minimum wage rates are included in PART II of these Supplementary Conditions. Where rates differ, the higher rates shall apply as a minimum for that trade.

E. The Contractor shall comply with all minimum wage rates in accordance with Rhode Island Department of Labor Laws (reference the General Laws of Rhode Island, Chapters 37-12 and 37-13, as amended). These rates may change without notice, and it is the responsibility of the Contractor to check and confirm at the time of the submission of a Bid that the rates used in the preparation of the Bid meet the most current wage rates issued. No additional compensation will be considered by the Owner for failure of the Contractor to comply with these requirements.

F. The Contractor shall regularly submit to the Owner, but no less frequently than his request for payment, certified payrolls for all his applicable employees performing work on the Project and for all his Subcontractors. Certified payrolls shall be submitted on "Statement of Compliance" forms or other such forms as prescribed and provided by the State of Rhode Island Department of Labor.

18.13 *Compliance*

A. All Subcontractors employed by the Contractor for the Work shall fully comply with the requirements of this Contract.

B. The Contractor shall bear full responsibility for compliance to the requirements of this Contract by both himself and by his Subcontractors. Submissions made to the Owner shall not relieve, nor be construed to relieve, the Contractor of this responsibility.

PART 2 - FEDERAL , STATE AND LOCAL GOVERNMENT PROVISIONS

Federal, State and Local Government Provisions included herein, have been selected from those to which specific references have been made elsewhere in the Contract Documents. Each and every other provision of law or clause required by law to be inserted in this Contract shall be deemed to be also inserted herein in accordance with Paragraph 3.01H of the Supplementary Conditions.

1. This Contract is subject to certain rules and regulations, especially those pertaining to bonds, labor and payment, minority/women businesses, disadvantaged business enterprises, and prevailing wage rates.
2. It is the responsibility of each Bidder to thoroughly research and make themselves fully aware of all Federal, State and Local laws, ordinances, regulations and requirements. It is the responsibility of each Bidder, Contractor, and all Subcontractors to ensure that they fully comply with all laws, ordinances, regulations and requirements.
3. Before a final payment and/or retainage is released, Contractor must submit a notarized confirmation by an officer of the company confirming that the Contractor and all their Subcontractors working on the Project have fully complied with all Federal, State and Local Labor laws, including but not limited to payment of prevailing wages and posting of said wages on-site.

1.0. FEDERAL GOVERNMENT PROVISIONS

1.1. Davis Bacon Act Requirements (Appendix H)

1.2. Federal Wage Rates

1.3. American Iron and Steel Requirements of P. L. 113-76, the Consolidated Appropriations Act of 2014 (Appendix G).

1.4. Build America, Buy America Act Requirements

This project is subject to American Iron and Steel and the Build America, Buy America Act (BABA). The amendments to the Clean Water Act, as part of WRRDA, apply the American Iron and Steel (AIS) requirements to all treatment works projects. Furthermore, Bipartisan Infrastructure Law (BIL) extends this procurement requirement to all State Revolving Fund (SRF) construction projects going forward with the inclusion of the Build America, Buy America Act (BABA). Starting on May 14, 2022, all steel, iron, manufactured products, non-ferrous metals, plastic and polymer-based products (including polyvinylchloride, composite building materials, and polymers used in fiber optic cables), glass (including optic glass), lumber, and drywall used in infrastructure projects for federal financial assistance programs must be produced in the United States. RIDOH ensures that the required procurement language is included in contracts and conducts field verifications of project compliance.

Domestic preference: Iron and steel products, Manufactured Products, and Construction Materials used in this project comply with the Build America, Buy America Act (BABAA) requirements mandated by Title IX of the Infrastructure Investment and Jobs Act (“IIJA”), Pub. L. 177-58.

1.5 EPA Debarment and Suspension (Appendix I)

1.6 EPA Prohibition on Certain Telecommunication and Video Surveillance (Appendix J)

1.7 EPA General Terms and Conditions (Appendix K)

1.8 EPA DBE Program (Section 00 10 00)

1.9 Regulations of the Secretary of Labor Anti-Kickback Act 40 U.S.C 276c (Appendix Q)

2.0. STATE GOVERNMENT PROVISIONS

2.1. Owner and Contractor agree that the following State Government Provisions apply to the work to be performed under this Contract and that these provisions supersede any conflicting provisions of this Contract.

2.2 State of Rhode Island General Laws: <http://webserver.rilin.state.ri.us/Statutes/>

2.3 State of Rhode Island General Law Chapter 37-13

The Contractor’s attention is specifically called to the provisions of Rhode Island General Law Chapter 37-13, Sections 37-13-1 through 37-13-13, as amended. The Contractor shall fully adhere to all provisions of the latest revision of this Chapter. Appending the referenced Sections of this Chapter of the State of Rhode Island General Laws shall in no way limit the responsibilities of the CONTRACTOR to comply with this and all other applicable Federal, State, and local laws. The CONTRACTOR shall verify that they comply with the latest version of this and all other such applicable laws.

2.4 State of Rhode Island Department of Labor and Training (Current Wage Rate Determinations & Laws, Rules and Regulations): <https://dlt.ri.gov/>

2.5 State of Rhode Island Office of Diversity, Equity & Opportunity (MBE/WBE Directory Search): <http://odeo.ri.gov/>

2.6 State of Rhode Island Office of Diversity, Equity & Opportunity MBE Forms (Appendix L)

2.7 State Wage Rates (Appendix R)

3.0 CITY PROVIDENCE, RHODE ISLAND PROVISIONS

3.1 City of Providence Code of Ordinances: <https://council.providenceri.gov/city-clerk/>

3.2 The City of Providence has initiated, by Section 21-52 of its Code of Ordinances and by Executive Order No. 1992-01, a Minority & Women Business Enterprise program. This program, by inclusion and reference, shall be considered part of this section. All Work performed under this Project and Contract shall be carried out in accordance with the requirements of this program. Subcontractor Payment and Utilization Report and MBE/WBE Project Utilization Summary forms are included at Appendix N.

3.3 City of Providence Apprentice Utilization, Local Hiring Requirements, and Air Quality Protocols are attached to and included in Appendix O.

3.4 City of Providence Contract Terms & Conditions are attached to and included in Appendix P.

END OF SECTION 007300.16

SECTION 01010
SUMMARY OF WORK

PART 1 GENERAL

1.01 LOCATION OF WORK

- A. The work of this Contract is located within multiple areas of the City of Providence and the northern area of the City of Cranston, Rhode Island. The Work Area is defined as the area shown in the Project Area Map in Appendix C of the Project Manual. A list of addresses for lead service line replacements is included in Appendix A of the Project Manual. These are addresses which are required to be contacted and inspected; if it is found that the service line is lead, and the homeowner signs the Right of Entry (ROE) and Release Form for Lead Service Line Replacement, the lead service lines are to be replaced.
- B. The Accelerated Lead Service Line Replacement Program will target replacements of lead service lines within multiple areas of the City of Providence and northern area of the City of Cranston, Rhode Island, as included in Appendix A. For the purposes of this project, galvanized steel is defined as a lead service line and should be removed and treated as if it was a lead pipe. Addresses may be added to and removed from the list in Appendix A by the Engineer or Owner within the defined Work Area throughout the project duration for a total of up to 1,219 service line replacements. Most replacements are likely to be full replacements (i.e. both public side and private side are replaced). However, some replacements may be on the public side only and some may be on the private side only. No partial replacements are allowed. A partial replacement is when a service line is lead on both the public and private sides and only one side is replaced while the side with lead is left in the ground. Contractor may perform replacements at addresses not listed in Appendix A only under the conditions discussed in Section 01170, Paragraph 1.18.I.

1.02 SCOPE OF WORK

- A. Furnish all labor, materials, equipment, and incidentals required to replace up to 1,219 lead service lines, and construct the Accelerated Lead Service Line Replacement Program in its entirety as specified herein and as shown in the details in Appendix B. All replacements will be full replacements, unless upon excavation the entire service line is observed to not be made of lead. In the event that only the service line from curb stop to meter or from the main to curb stop consists of lead, it shall be considered a private side or public side only replacement, respectively.
- B. Provide adequate workforce including service replacement crews, restoration crews, plumbers, and subcontractors to execute the work within the Contract Duration while maintaining a minimum monthly quota of 80 completed service replacements per winter month (December to March) and a minimum monthly quota of 100 completed service replacements per summer month (April to November) starting in the second month of the contract. The Owner may terminate for cause if the Contractor fails to maintain a minimum monthly quota of 80 service replacements per winter month or 100 service replacements per summer month.
- C. The Work includes, but is not necessarily limited to, the following:

1. Furnishing and installing new copper service tubing, corporation stop, curb stops and boxes, ball valves, core drilling and adapters and fittings of the necessary size required to reinstate water service to the customer, and disposal of existing domestic lead water service lines in accordance with all local, state, and federal requirements including corporation stops, curb stops and boxes, valves, and adapters. Existing service lines shall be replaced with the new service lines of diameter closest (and rounded up) to the next incremental size of 1-inch, 1.5-inch and 2-inch diameter. New 1-inch service lines shall replace all existing service lines less than or equal to 1-inch. New 1.5-inch service lines shall replace all existing services lines greater than 1-inch and less than or equal to 1.5-inch. New 2-inch service lines shall replace all existing services lines greater than 1.5-inch and less than or equal to 2-inch. All work required for lead service line replacements, including but not limited to:
 - a. Coordination with the Owner
 - b. Obtaining the Right-of-Entry (ROE) and Release Form for Lead Service Line Replacement from homeowners.
 - c. Coordination and scheduling of work on private property with Customer (which shall include property owners, residents, tenants, and businesses)
 - d. Coordination with other contractors working on other projects within the Work Area
 - e. Traffic control, including uniformed police officers and flaggers, as required
 - f. Test pits
 - g. Pavement and concrete removal, including saw cutting, as required
 - h. Excavation and backfilling
 - i. Removal and proper legal disposal of lead service lines, concrete, asphalt, vegetation, excess soil, and other surplus waste and materials in accordance with all local, state, and federal requirements
 - j. Dewatering and shoring
 - k. Trenchless installation, and open-cut installation when needed
 - l. Leakage testing and flushing of new service lines in accordance with AWWA Standard C810
 - m. Connecting to existing or newly installed water meter
 - n. Installation of a new ball valve upstream of the water meter and downstream of the water meter, when replacing the private-side.
 - o. Relocating meters and filling existing meter pits with concrete
 - p. Replacing, furnishing, and installing all required ball valves, adapters, reducers, fittings, flare adapters, pressure reducing valves, backflow devices, expansion tanks, reduced pressure zone (RPZ) backflow preventers (if required), and appurtenances of the necessary size required and as required by Rhode Island Plumbing Code.
 - q. Temporary water service (as required)
 - r. Photographic documentation of pre and post-construction activities and interior and exterior conditions for each property.
 - s. Documentation of contractor's work and photographs in leadCAST;
 - t. All temporary surface restoration work in accordance with local municipality permit conditions
 - u. All final surface restoration work to restore all areas disturbed by construction to conditions equal to or better than pre-construction conditions in accordance with local municipality permit conditions as shown in Appendix C.
 - v. Furnishing a technician from an Independent Testing Laboratory who shall be on-site for at least 10 days while work is taking place to perform all specified testing. All

coordination, labor, analysis, and reporting related to testing at each excavation for those 10 days shall be included in Bid Items 1A or 1B, as applicable.

- w. Permits, all required supporting documentation, and all associated permit fees including but not limited to road opening (municipal and state), plumbing, sidewalk opening, street closing, and all other permits required to complete work. Contractor to prepare all required traffic management and detour plans to obtain required road opening permits. Contractor shall prepare and submit the plumbing permit on behalf of the Customer and coordinate inspection with the municipality.
2. All other work required for successful completion of the Work as specified.

1.03 WORK BY LICENSED PLUMBER

- A. The following work shall be performed by a licensed plumber in accordance with Rhode Island Plumbing Code under this Contract:
 - 1. Check electrical grounding before cutting into existing water line as specified in Section 02663. Make grounding modifications as required in Section 02663.
 - 2. Installation of new interior copper piping.
 - 3. Installation of new full port ball valves of the necessary size in building interior upstream and downstream of the existing building water meter.
 - 4. All required interior piping modifications to meet the local plumbing code, including installation of an expansion tank and a pressure reducing valve, and for the convenience of the installation.
 - 5. Final connection to the existing water meter.

1.04 CONTRACTOR'S USE OF PREMISES

- A. Coordinate all work with Owner, Engineer, and Customer to facilitate the usage of water services lines, with minimal conflicts and interruptions to the water service.
- B. Coordinate work to allow full, uninterrupted access to all residences and businesses, and allow for pedestrian access around work zones and closed sidewalks. Contractor shall limit the use of the premises for his/her Work and storage to allow for:
 - 1. Work by other contractors or by Owner.
 - 2. Access of public to homes and businesses.
 - 3. Public use and safety.
 - 4. Fire Protection.
- C. Coordinate use of premises with Owner, Engineer, and Customer prior to the start of Contractor's work thereon.

- D. Contractor shall assume full responsibility for the security of all his/her personnel, materials, and equipment stored on the project including all subcontractors.
- E. If directed by the Owner or Engineer, move any stored items or containers that interfere with operations of Owner, other contractors, Customer or public.
- F. Obtain and pay for the use of additional storage or work areas if needed to perform the Work.

1.05 OWNER AND CUSTOMER OCCUPANCY

- A. Customer (Private property owners, tenants, businesses and residents) will occupy premises during the performance of the work. Coordinate all construction operations with Customer, Owner, and Engineer to minimize conflict and to facilitate usage and occupancy during construction.
- B. Owner or Engineer will provide residents with point-of-use pitcher filters, replacement cartridges, and installation and use instructions through PWSB's current pitcher filter distribution program.

1.06 ROAD WORK

- A. Road work in City of Providence, City of Cranston, or State of Rhode Island rights-of-way shall conform to City or RIDOT requirements where applicable. Contractor shall obtain all permits necessary.
- B. All traffic control devices shall be in accordance with the Manual on Uniform Traffic Control Devices, published by U.S.D.O.T., Federal Highway Administration latest revision, and local police and government requirements.
- C. Where permission is granted to the Contractor by the authority having jurisdiction for the use of road plates to secure excavations on a temporary basis, all road plates shall be recessed to match existing pavement surface and shall be secured with at least four railroad spikes per plate (minimum one spike in each side of plate). Road plates are not permitted to be used between November 15th and April 15th.
- D. No public-side only or full replacements on roads under a 2019 moratorium shall be completed before 2025.
- E. Traffic Control Officers will be paid from the Uniformed Police Traffic Control Allowance. When not available, Flaggers can be used and will be paid from the Flagger Traffic Control Allowance.

END OF SECTION

SECTION 01014
CONSTRUCTION SEQUENCE AND SCHEDULE REQUIREMENTS

PART 1 GENERAL

1.01 GENERAL REQUIREMENTS

- A. Provide adequate workforce including service replacement crews, restoration crews, plumbers, and subcontractors to execute the work within the Contract Duration while maintaining the minimum monthly quota as specified in Section 01010.
- B. The water distribution system must provide continuous service to all customers during the construction period and meet all demands required under normal service conditions with the exceptions permitted herein when directly replacing a Customer's water service line.
- C. Submit a proposed construction sequence with a detailed sequence of work for the work area. Contractor shall submit the following for Engineer and Owner review:
 - 1. Lead service line replacement plan including:
 - a. Detailed activities with estimated durations (i.e., contacting the Customer, verifying pipe materials, installing the new water service line, removing or abandoning the existing water service line, flushing, and testing, placing into service, restoring, etc.).
 - b. Number of Contractor construction crews
 - c. Estimated construction duration for each crew in each area
 - d. Estimated service downtime for each Customer
 - 2. Traffic management and detour plans.
- D. In general, no work which affects or could affect system operations shall be performed without a specific detailed plan by the Contractor approved in advance by the Engineer and the Owner. All requests shall be in writing to the Owner and Engineer.
- E. Construction progress schedules required shall reflect the conditions presented in Section 01310.
- F. No City of Providence Department of Public Works controlled roads can be opened after November 15th or before April 15th.
- G. No public-side only or full replacements on roads under a 2019 moratorium shall be completed before 2025. Contractor shall not schedule replacements meeting this criteria before 2025, when the moratorium expires.

1.02 DEFINITIONS AND TERMS

- A. System Operational Constraints: The constraints to the performance of the work required because of system operations which must be maintained at all times are identified in this section. These constraints shall be included in the Contractor's progress schedule and plans.
- B. Construction Scheduling Constraints: The constraints to the performance of the work required because of special sequencing with other parts of the work, calendar time constraints and

special testing, commissioning and work procedures are identified in this Section. These constraints are in addition to the standard procedural constraints such as shop drawings, testing, commissioning, training, etc. and the above plant operational constraints. These constraints shall be included in the Contractor's progress schedule.

- C. Special Conditions: Certain special conditions, if any, related to performance or scheduling of the work. Special conditions are identified in this section and Section 01170. If they affect the scheduling of the work, they shall be included in the Contractor's progress schedule.
- D. Owner: Providence Water Supply Board, Providence, Rhode Island
- E. Engineer: CDM Smith Inc., 3 Davol Square, Building A Suite A 425, Providence, Rhode Island.
- F. Customer: The property owners, homeowners, residents, tenants and businesses that will be impacted by the replacement of water service lines and the Contractor's activities occurring as part of this project.
- G. Work Area: Consists of the addresses provided in Appendix A.

1.03 SUBMITTALS

- A. Submit proposed construction sequence with a detailed sequence of work in accordance with the requirements herein and of Section 01300 for Engineer and Owner review and approval prior to starting construction.

1.04 NOTIFICATION REQUIREMENT

- A. Give a minimum of 72 hours advanced notice via door hanger to the Customers of any service line to be replaced or water service disrupted. In addition, notify the customer via a 24-hour notice within 24 hours of the replacement to remind them to provide access and to remind them of the hours they should anticipate being without water.
- B. In addition, the Contractor shall provide and distribute door hangers a minimum 72 hours in advance to residents that may be affected by construction activities and the potential interruption of water service, traffic or parking areas on the street.
- C. "No parking" signs shall be posted for a duration of no more than 5 days at one time and shall be posted at least 24 hours in advance of work commencing at that address.
- D. All work, including customer scheduling, color printing (double-sided full color on white paper) and distributing door hangers, shall be included as part of the replacement bid item corresponding with the replacement scheduled at the property and shall be the responsibility of the Contractor.
- E. All registration information will be printed and/or distributed by the Owner.
- F. If the homeowner refuses entry or does not grant the Contractor access to perform an internal inspection, Contractor shall document rejection and provide to Owner and Engineer. Contractor shall not perform a test pit. Contractor shall not charge for any work at locations with documented rejections.

1.05 CONNECTION PREPARATIONS

- A. Where new service piping shall be tied-into existing piping, the new piping installed by Contractor shall be fully prepared in anticipation of the final connection in order to minimize downtime. Coordinate all work as required with Engineer and Owner so that the final connections can be made to the existing water meter. If no water meter previously existed or a new water meter installation is necessary, the Contractor should notify the Owner immediately. See Section 01170 for requirements related to coordination for connection of new water service lines to existing building water meters.
- B. Perform a flush as specified in Section 02663 after any type of replacement is conducted. Flushing shall of the entire service line.

1.06 SITE CONDITIONS

- A. Locations for lead service line replacement as part of this Contract and typical details for water service connection replacement are included in the appendices of these Specifications. Each location will vary and have unique site conditions. Additional addresses may be added by the Owner or Engineer within the defined Work Area.
- B. Coordinate all work and work activities with the Owner, Engineer, and Customers as specified.
- C. Coordinate the activities with other contractors, if any, to allow the orderly and timely completion of all the work.

1.07 OPERATIONAL CONSTRAINTS

- A. The following is a list of operational constraints to consider in developing the overall plan of construction. This list is not intended to release the Contractor from the responsibility to coordinate the work in any manner which will ensure project completion within the time allowed or to complete the work while maintaining the safety and integrity of the water system. These requirements are such that the Owner can maintain proper flow, pressures and fire flows to the water system at all times. The safety and integrity of the water system are of prime importance.
 - 1. Water service lines to be replaced in the Owner's distribution system have typical normal operating pressures ranging from 60 psi to 70 psi. The Contractor is responsible for verifying and documenting the operating pressure at all locations prior to performing any work.
 - 2. The water distribution system must provide continuous service to all customers during the construction period and meet all demands required under normal service conditions except as permitted herein.
 - 3. All work for lead service line replacements at each location must be completed in a maximum time not to exceed 8 hours from arrival on-site. One (1) temporary shutdown of service line per location will be allowed to facilitate replacement of the lead service line with the shutdown not exceeding 8 hours. In no case shall any customer or location be without potable water service for longer than 8 hours. Provide temporary service, in accordance with Section 01046, if the shutdown will be longer than 8 hours, at Contractor's expense.

4. Unless otherwise approved by the Engineer and Owner, all work shall be performed with water mains live and in service as specified in Section 02663.

1.08 CONSTRUCTION SCHEDULING CONSTRAINTS

- A. The following is a list of scheduling constraints to consider in developing the overall plan of construction. This list is not intended to release the Contractor from the responsibility to coordinate the work in any manner which will ensure project completion within the time allowed. The following items are not necessarily listed in their order of priority or required sequence of construction.
 1. Coordinate all work activities with the Owner, Engineer, and Customer as specified to allow orderly and timely completion of all required work.
 2. Contractor shall be aware of elections, school schedules, certain festivals and activities that occur in the City which may restrict work at certain times. These activities may cause changes in traffic patterns and road closures in areas of the City. Contractor is responsible for being aware of the dates, times and locations of all festivals and activities that may be located in work areas and require adjustments to the construction schedule. Coordinate all work with Owner and Engineer.
 3. Restrictions for placement of final, permanent paving is as specified in Section 02576. All work should be timed to avoid the need to place initial pavement during cold temperatures, as defined in Section 02576.
 4. All initial pavement over trenches and excavations, in the form of hot patch, shall be completed by the end of each workday. No trench or excavated area shall be left past the end of the day without initial pavement placed and installed.
 5. Final road restoration shall be completed on the streets shown in Appendix C.
 6. The Right-of-Entry (ROE) and Release Form for Lead Service Line Replacement must be obtained before any replacement work can commence on a customer-owned portion of the service line. ROE must be submitted to and approved by the Owner before any work at that address takes place.
 7. The Contractor shall be capable of providing multiple crews as needed to complete the work without undue delay.
 8. All documentation of service line materials (pre and post-construction) and work performed shall be made in leadCAST by the end of each workday for the day on which the work is performed.

1.09 HOURS OF CONSTRUCTION

- A. The Contractor's hours of operation will be limited to an 8-hour shift between the hours of 7:00 AM to 3:30 PM on Mondays through Fridays only. There shall be no work performed on Saturdays, Sundays, holidays, or outside the hours of operation unless prior written approval is obtained by the Contractor from the Engineer and Owner.

- B. Work hours shall be as indicated above with the exception of the local requirements for the City or for the type of roadway or location. The Contractor is responsible for following all local codes, ordinances and permit conditions where the work is taking place.

1.10 ADVERSE WEATHER

- A. The schedule submittal to the Engineer must include planning for typical adverse weather in the project area over the duration of the contract.
- B. The Contractor must provide the Engineer evidence of excessive weather conditions in excess of the adverse weather typically expected by the National Oceanic Atmospheric Administration (NOAA) (<https://www.ncei.noaa.gov/>, 828-271-4800) for the project area, in order to justify a delay due to excess adverse weather (i.e., unusually severe weather).
- C. Time Extension for unusually severe weather:
 - 1. This provision specifies the requirements for the consideration of time extensions for unusually severe weather. In order for the Engineer to grant a time extension, the following conditions must be satisfied.
 - a. The weather experienced at the project site during the Contract period must be found to be unusually severe, that is, more severe than the adverse weather determined to be typical for the project area according to the NOAA website.
 - b. The unusually severe weather must actually cause a delay to the completion of the project. The delay must be beyond the control and without the fault or negligence of the Contractor.
- D. Upon acknowledgement of the Notice to Proceed (NTP) and continuing throughout the contract, the Contractor shall record on the project schedule, the occurrence of adverse weather and resultant impact to normally scheduled Work.

PART 2 PRODUCTS (NOT USED)

PART 3 EXECUTION (NOT USED)

END OF SECTION

SECTION 01025
MEASUREMENT AND PAYMENT

PART 1 GENERAL

1.01 SCOPE

- A. This Section includes specifications for the measurement and payment of the various elements of the Work, with provisions applicable to lump sum prices, unit prices, and allowances, if applicable.
- B. In the case of conflict between this Section and the measurement methods specified in the individual technical Sections, the measurement methods in the technical specifications shall govern.
- C. The Contractor shall receive no payment for any portion of the work until it is installed and accepted by the Engineer. The only exception to this is payment for stored materials on-site if the Contract provides for the payment of stored materials. A partial payment may be requested for items partially installed.

1.02 RELATED WORK

- A. Bid Form is included in Section 00 41 00.
- B. General Conditions are included in Section 00 72 00.
- C. Applications for Payment are included in Section 01026.
- D. Schedule of Values is included in Section 01370.

1.03 LUMP SUM ITEMS

- A. Lump Sum measurement will be for the entire item, unit of work, structure, or combination thereof, as specified and as indicated in the Bid Form. Measurement and payment for all bid items indicated as Lump Sums shall include the cost of all labor, materials, and equipment necessary to furnish, install, clean, test, and place each bid item into operation, including general conditions, overhead and profit.
- B. Progress payments will be based on the Schedule of Values prepared by the Contractor and approved by the Engineer and Owner before acceptance of the first Application for Payment.
- C. In order for the Contractor to request progress payments against Lump Sum items, Contractor shall provide a disaggregation or breakdown in sufficient measurable detail that is acceptable to the Engineer.
- D. Measurement
 - 1. Measurement shall be based on the estimated percent complete of each item of the Schedule of Values, as determined by the Engineer.

E. Payment

1. Payment will be made at the lump sum price proportional to the completion percentages approved by the Engineer.
2. Contactor must track and maintain copies of all necessary permits submitted. Retainage as specified in Section 00 73 00 will be held until all permits are approved, paid for and received by Engineer and Owner.

1.04 UNIT PRICE ITEMS

- A. Quantity and measurement estimates stated in the Bid Form are estimates for bidding purposes only. Actual payments shall be based on actual quantities installed, in-place, as measured and/or verified by the Engineer.
- B. Unless otherwise provided in the General Conditions, the bid unit prices shall be in effect throughout the contract duration, regardless of variances between the estimated quantities and the actual quantities.
- C. The Contractor shall make no claim, nor receive any compensation, for anticipated profits, loss of profit, damages, or any extra payment due to any difference between the amounts of work completed, or materials or equipment furnished, and the estimated quantities.
- D. Assist Engineer by providing necessary equipment, workers, and survey personnel as required to measure quantities.
- E. Measurement
 1. Measurement for progress payment shall be made by, or approved by, the Engineer based on the estimated effective quantity installed. The effective quantity installed represents the actual units or quantities installed, adjusted for incomplete elements or components.
 2. Unless otherwise provided for in the Bid Form, unit price items are all-inclusive of all related work, direct and indirect, to provide a complete and functional item.
 3. The final measurement shall be based on actual quantities, jointly measured by Contractor and Engineer, complete, fully, tested and placed into service.
- F. Payment
 1. Progress payments shall be in accordance with the contract documents based on estimated effective quantities installed, paid at the bid unit price.
 2. The final payment shall be based on actual quantities, fully installed, tested, and placed into service, paid at the bid unit price.

1.05 ALLOWANCES

- A. Allowances, if any, specified in the Contract Documents and indicated in the Bid Form are considered provisional amounts to be used only as needed.

- B. Allowances are exclusive of work indicated in the Contract Documents for which payment is included under other items in the Bid Form. No work may be performed under an allowance without the prior written approval of the Owner.
- C. Any unused balance of the allowances shall revert to the Owner upon completion of the project. Prior to final payment, the original amount provided for allowances shall be adjusted to actual costs by deductive Change Order, adjusting the contract price, accordingly.
- D. The Contractor shall make no claim, nor receive any compensation, for anticipated profits, loss of profit, damages, or any extra payment due to any unexpended portion of the allowances.
- E. Include time for allowance work in the construction schedule. No adjustment of Contract Time will be allowed for any work performed under allowance items.
- F. Allowance items shall be included in the Schedule of Values.
- G. Unless otherwise indicated in the specific measurement and payment provisions under allowance items, the measurable and allowable costs for work performed under an Allowance item shall be limited to the actual, demonstrable, and direct costs associated with that Allowance item. Shipping and sales taxes (if applicable) are allowable costs.
 - 1. No markup for overhead or profit (including cost for bonds) shall be included for payment under an Allowance item. Overhead and profit (including cost for bonds) shall be included in the contract base bid or allocated across other bid items.
 - 2. Work authorized by the Owner under an allowance may be performed as a lump sum (negotiated before the fact), unit prices (when applicable), or time and material. For work performed under time and material, submit detailed verification (break-down) of all costs, subject to the approval of the Engineer or Owner. Time and material records shall be submitted to the Engineer on a daily basis and in no case later than 48 hours after the work is performed.

1.06 DEFECT ASSESSMENT

- A. Replace defective Work, or portions of defective Work, not conforming to specified requirements.
- B. If in the opinion of the Engineer, it is not practical to remove and replace the Work, the Engineer will direct a remedy in accordance with the requirements of the General Conditions.

1.07 NON-PAYMENT FOR REJECTED PRODUCTS

- A. Payment will not be made for any of the following:
 - 1. Products wasted or disposed of in a manner that is not acceptable.
 - 2. Products determined as unacceptable before or after placement.
 - 3. Products not completely unloaded from the transporting vehicle.

4. Products placed beyond the lines and levels of the required Work.
5. Products remaining on hand after completion of the Work.
6. Loading, hauling, and disposing of rejected products.

PART 2 PRODUCTS – NOT USED

PART 3 EXECUTION

3.01 PUBLIC SIDE BID ITEMS (ITEMS 1A-1I)

A. General

1. Replacement Items

- a. Trenchless or other approved means of lead water service line replacement which may include replacement of the public side only service line (Item 1A), replacement of the public side portion of a full replacement (Item 1B), and replacement of all necessary appurtenances. All replacements on the public side shall include mobilization, (sanitary facilities, insurance, temporary construction facilities, construction vehicle parking and storage, bonds, permit acquisition, permit fees, labor, project coordination, control of work, project signs, coordination with homeowner and inspectors, scheduling, notifications, printing, all data and record document management, and preparation of contract required submittals); removal and disposal of excess soil, spoil, rubble, lead pipes and construction debris, vegetation and similar items; stockpiling, sampling and testing, all labor, materials, new corporation stop, temporary roadway, temporary and permanent sidewalk and/or yard restoration, equipment required for erosion and sediment control, and protection of existing trees as approved by the Engineer; all work required for or incidental to the satisfactory completion of the Work.
- b. Each property listed by the Owner in Appendix A, or the updated list in the database management system at the time of construction, is the target list for construction. Each property with a signed ROE agreement must have a replacement completed or, if no lead is found on either side, a test pit. Public side only replacements (Item 1A) do not require a signed ROE, however, private side material must be confirmed prior to scheduling the public side only replacement in the event the record on the private side is incorrect and is actually lead. If the private side is lead, both sides must be replaced at the same time after obtaining an ROE from the homeowner.

2. Test Pit at Curb Stop (Item 1C)

- a. A test pit is defined as a planned service line replacement that is found not to be lead on either side or a property where the Owner or Engineer specifically directs the Contractor to perform a test pit.
- b. If there is more than one service in the same excavation as a planned replacement, Contractor must notify the Owner of observed materials at all properties. Contractor

must make every effort to inspect and photograph all properties within the excavation. Only test pits at locations in Appendix A (or added to the data management system) with signed ROE, or as directed by the Owner or Engineer, will be paid for under Item 1C.

3. New Curb Box (Item 1D)
 - a. For when a new curb box is needed when replacing the private-side only service line for a commercial property. Curb boxes that are needed to be replaced during a test pit at the commercial property at the direction of the Engineer.
4. Long-Side Replacement (Item 1E)
 - a. A long-side replacement is when the resident with the service line being replaced is on the opposite side of the street from the water main. The distance from the water main to the curb must be greater than half the roadway width for a replacement to be considered a long side replacement. Water mains with a centerline within 1-foot of the center of the road do not have long-side replacements on either side.
5. Lead Service Line Excavation Greater Than 5 Feet (Item 1F)
 - a. Lead water service trenching to a depth of greater than 5-feet and non-hazardous waste disposal; shoring; dewatering; installation, backfill; compaction; including all labor, materials, and equipment necessary. All excavation to a depth of 5-feet is included in the replacement bid items.
6. Final Trench Pavement Restoration (Infra-red) (Item 1G); Final Trench Pavement Restoration (Milling and Paving) (Item 1H); Final Pavement (Curb-to-curb) (Item 1I)
 - a. In general, final pavement restoration will be undertaken only on streets shown with an outer yellow circle on Appendix C where any construction work is performed within the roadways as a result of service line replacement or otherwise deemed necessary in the field. Final pavement on streets shown in red will be required to be restored by either mill and pave (patch paving at trench locations), infra-red, or curb to curb (full width paving) methods, based on the paving requirements of the Department of Public Works or RIDOT permit issued. Streets shown in Appendix C without the outer yellow circle do not require roadway restoration due to being private-side only replacement. Pavement replacement necessary resulting from the activities of the Contractor outside of the limits defined in the Details in Appendix B shall be paid for by Contractor. Payment of restoration does not relieve the contractor of responding to complaints by Customers and returning, for the period of the 5-year warranty, to make necessary repairs.
 - b. Owner will make every effort to ensure the proposed quantities for pavement restoration will be provided to the Contractor. However, if the final restoration area is less than the bid quantity, Contractor shall have no claim to modify the price of the unit price item.
 - c. Final Pavement (Curb-to-curb, full width paving of a block or street) will be used at the direction of the Engineer when initial paving areas encompass a majority of the pavement surface and as required by the Owner or Department of Public Works and

as defined by the Rhode Island Department of Transportation Minimum Standards for State and Municipal Road Repair for Utility Work.

- d. Only one of the paving items (Items 1G-1I) will be applied per public side lead service line address.

B. Measurement

1. **(Item 1A) Lead Service Line Replacement – Public Side Only** - Measurement will be based on the number of installations completed from the water main to the curb stop within the Work Area and shall be contingent on the submission of comparable pre-construction and post-construction photographs of each installation and complete record documents, including all permits, for each property. When only a public side only replacement (i.e., from water main to curb stop) is completed at a property, the Contractor shall be paid under Item 1A. Replacement includes all road opening and street closure permit acquisition and fees, piping, curb stop valve and box, new corporation stop, appurtenances to make all connections, procurement and placement of warning tape, flushing at the meter, leak testing, equipment required for erosion and sediment control, protection of existing trees, and temporary paving, temporary and permanent sidewalk and/or yard restoration. Full Replacements will not be paid for under this item.
2. **(Item 1B) Lead Service Line Replacement – Public Side Portion of a Full Replacement** - Measurement will be based on the number of installations completed from the water main to the curb stop within the Work Area, only where the private side of the service line is also being replaced (full replacement) and shall be contingent on the submission of comparable pre-construction and post-construction photographs of each installation and complete record documents, including all permits, for each property. Replacement includes all road opening and street closure permit acquisition and fees, piping, curb stop valve and box, procurement and placement of warning tape, flushing at the hose bib, leak testing, equipment required for erosion and sediment control, protection of existing trees, temporary paving, temporary and permanent sidewalk and/or yard restoration, and appurtenances to make all connections. Full Replacements performed under this contract within the Work Area will be paid for as the sum of Item 1B and Item 2B.
3. **(Item 1C) Test Pit at Curb Stop** - Measurement will be based on the number of locations in Appendix A (or most updated list as provided during construction in the database management system), and those properties that the Owner or Contractor has acquired a Right-of-Entry and Release Form for, where pipe material in the test pit was found not to be lead on both the private side and the public side or where directed by the Owner or Engineer and all material information is documented by Contractor. Submit comparable pre-construction and post-construction photographs of each test pit, and Owner and Engineer shall accept the surface restoration of the test pit prior to payment. Temporary and permanent sidewalk and/or yard restoration shall be included in this item.
4. **(Item 1D) New Curb Box – Commercial – Private Side Only** - Measurement will be based on the number of curb boxes replaced for private-side only replacements at commercial properties (Item 3A) and curb boxes replaced during a test pit at a commercial property at the direction of the Engineer (Item 1C). Curb box and valve replacements are already included in Items 1A and 1B for public side replacements.

5. **(Item 1E) Long-Side Replacement** - Measurement will be based on the number of long-side replacements. This Item will be paid in addition to either Bid Item 1A or Bid Item 1B to cover the cost of the additional time and material for the additional length of service line required to be replaced.
6. **(Item 1F) Lead Service Line Excavation Greater Than 5 Feet** - Measurement will be based on the actual depth of excavation beyond a 5-foot depth, as approved by the Engineer, for a maximum trench width as shown in Details, if and when directed. If the trench bottom is more than twelve inches below pipe invert through an error by the Contractor or if improper drainage softens the subgrade and additional excavation in the trench or access pit is required before laying the pipe or installing the water service line, such removal and replacement of material will not be paid for by Owner. Measurement by truck count will not be permitted.
6. **(Item 1G) Final Trench Pavement Restoration (Infra-Red)** - Measurement will be based on the square yard(s) installed on streets, as directed by the Engineer, and as measured by the Engineer, within the specified widths and completed between 45 and 90 days of placing the temporary paving. This item shall include milling and paving of the trench and infra-red sealing of the seams.
7. **(Item 1H) Final Trench Pavement Restoration (Milling and Paving)** - Final Pavement Restoration (Milling and Paving) - Measurement will be based on the square yard(s) of patch paving installed at each trench as measured by the Engineer, within the specified widths and completed between 45 and 90 days of placing the temporary paving.
8. **(Item 1I) Final Pavement (Curb-to-curb)** - Measurement will be based on square yard(s) of full width, curb-to-curb, entire block, or street paving installed as measured by the Engineer, if and when directed or required by the Road Opening Permit.

C. Payment

1. Full payment for **Item 1A Lead Service Line Replacement – Public Side Only and Item 1B Lead Service Line Replacement – Public Side Portion of a Full Replacement** shall be provided once the following components are completed:
 - a. **Administration:** Price and payment shall include, but not be limited to customer coordination, printing and distributing door hangers for notifications of service disturbance, procurement and posting of no parking signs, local agency coordination for permits, permit fees, inspections and scheduling; pipe material validation through interior inspection; underground utility mark outs and coordination, pre-construction photographs; and all other preliminary documentation as required by the Contract.
 - b. **Site Preparation:** Price and payment shall include, but not be limited to temporary traffic control including traffic signage; erosion and sediment control; mobilization (sanitary facilities, insurance, temporary construction facilities, construction vehicle parking and storage, bonds, permit preparation and fees, state roadway inspector when working on state roadways, project coordination, control of work, project signs, scheduling, and preparation and submittal of contract required work plans); cutting existing pavement, pavement including subbase depth to match existing; temporarily

support and protection of all existing utilities and structures; all trench excavation up to depth of 5 feet (including hand, vacuum, rock and boulders and concrete road base excavation); excavation support and protection (as required); dewatering and drainage.

- c. **Service Replacement:** Price and payment shall include, but not be limited to: temporary water for customer (as required); furnishing and installation of water service line (up to and including 2-inches in size) to limits defined in individual bid items by trenchless methods or by open-cut methods when approved by the Engineer, including pipe, new corporation stop, curb stop valve and box, all the necessary adapters, reducers, fittings and appurtenances of the necessary size required to connect to existing piping; flushing, testing of the new service line, placing the service line into service; existing lead water service line and appurtenances removal, disposal, demolition or abandonment; backfill materials shown in Appendix B; compaction and compaction testing; restoring the trench surface to grade or the limits of roadway base course; restoring the existing curb to grade; stockpiling, sampling and laboratory testing of excess excavated material including, but not limited to, spoil, rubble, concrete, asphalt, vegetation, etc. Payment for these items shall include all work required for or incidental to the satisfactory completion of the Items for which payment is not provided under other items in the Bid Form.
 - d. **Restoration on Public Side:** Price and payment shall include, but not be limited to temporary traffic control; GPS coordinates of the corporation stop, curb stop, and where the service line enters the house (for full service), service application records, closeout documentation including photographs; repairs and cleaning of interior work spaces; procurement and placement of warning tape; restoring exterior physical features; temporary paving restoration; temporary and permanent sidewalk and/or yard restoration; forming and pouring concrete curbs to match sidewalk elevation, concrete testing and all other testing required to complete the project as specified herein; transportation and disposal of excess excavated material, spoil, rubble, concrete, asphalt, vegetation, lead pipes and construction debris, etc. in accordance with all Federal, State and local regulations; including all labor, materials and necessary equipment; removal of erosion and sediment control devices; all work required for or incidental to the satisfactory completion of the Items for which payment is not provided under other items in the Bid Form.
 - e. All items, including restoration, must be fully completed prior to requesting payment in full for Bid Items 1A and 1B. A payment of 50% can be requested if a service line is installed but the restoration is not yet complete.
 - f. When a private side only replacement (i.e., from curb stop to meter) is completed at a property, the Contractor shall be paid under Item 2A.
2. Payment for **Item 1C - Test Pit at Curb Stop**, shall be made as follows: Payment for this Item shall be provided for the Contractor completing 3.01-C.1a Administration, 3.01-C.1b Site Preparation, performing the test pit, and 3.01-C.1d. Test pit shall assume excavation is in concrete and temporary and permanent sidewalk restoration is included in this bid item. Payment for Item 1C will only be made if the entire water service line (corporation stop to meter) is found not to be lead. No payment will be made under this Item if any pipe

replacement is performed. If the curb box is replaced without a portion of the service line being replaced, payment will be made under Item 1C plus Item 2C for the curb box. Contractor will not receive payment for Item 1D if the curb box is damaged during excavation.

3. Payment for **Item 1D New Curb Box** shall be made in full for all private side only replacements (Item 2A) when a public side replacement (Item 1B) does not occur at the same location and the curb box is replaced. Payment shall also be made in full if a curb box is replaced during a test pit when the curb box is considered in need of replacement by the Engineer.
4. Payment for **Item 1E - Long Side Replacement** shall be made as follows: When the Contractor performs a long-side replacement (i.e., when the resident with the service line being replaced is on the opposite side of the street from the water main it will be supplied from), Contractor will be paid for the service line replacement under the replacement bid items (1A or 1B as applicable), however, an additional payment under this bid item will be made to cover the additional work associated with performing trenchless or open-cut installation across utilities in the roadway. This item shall include the additional excavation, backfill, temporary restoration, pipe and all other items associated with a long-side replacement that are not included in a short-side replacement. All items associated with administration, site preparation, service replacements and restoration shall be included in Item 1A or 1B, as applicable with this item being an additional payment for long-side replacements.
5. Payment for **Item 1F - Lead Service Line Excavation Greater Than 5-Feet** shall be as follows: All work associated with excavation beyond 5-feet in depth shall be included under this bid item unless otherwise stated. Price and payment shall be full compensation for, but not limited to, protection of all existing utilities and structures; excavation (including hand excavation); loading; hauling; excavation support and protection; dewatering and drainage; temporarily support of utilities; backfilling with native soil; compaction, testing by technician from the Soils Testing Laboratory; removal of debris, spoils, pipe, tubing, rubble, vegetation, and similar items removed and legally disposed, including all labor, materials and necessary equipment; all work required for or incidental to the satisfactory completion of the Items for which payment is not provided under other items in the Bid Form. Payment for excavation 5-feet or shallower is included in Items 1A, 1B, 2A, 2B, 3A or 3C as applicable.
6. Payment for **Item 1G - Final Trench Pavement Restoration (Infra-Red)** shall be as follows: All work associated with final infra-red pavement, shall be included under this bid item unless otherwise stated. Price and payment shall be full compensation for, but not limited to: sweeping, cleaning and preparing the base course surface; traffic control, traffic signage; cutting back existing pavement, furnishing, hauling, heating, raking mixing and placing the final pavement, compacting, testing, pavement marking restoration, including all labor, materials and necessary equipment; all work required for or incidental to the satisfactory completion of the Items for which payment is not provided under other items in the Bid Form.
7. Payment for **Item 1H - Final Trench Pavement Restoration (Milling and Paving)** shall be as follows: All work associated with final milling and paving, shall be included under

this bid item unless otherwise stated. Price and payment shall be full compensation for, but not limited to: sweeping, cleaning and preparing the base course surface; traffic control, traffic signage; cutting back existing pavement, milling and disposal, installation of tack coat, furnishing, hauling, and placing the final pavement, compacting, testing, pavement marking restoration, including all labor, materials and necessary equipment; all work required for or incidental to the satisfactory completion of the Items for which payment is not provided under other items in the Bid Form.

8. Payment for **Item 11 - Final Pavement (Curb to Curb)** shall be as follows - All work associated with final pavement restoration shall be included under this bid item unless otherwise stated. Price and payment shall be full compensation for, but not limited to: sweeping, cleaning and preparing the base course surface, traffic control, traffic signage;; milling and removing initial or existing pavement surface, installation of tack coat, furnishing, hauling and placing the final pavement, compacting, pavement marking restoration, including all labor, materials and necessary equipment; all work required for or incidental to the satisfactory completion of the Items for which payment is not provided under other items in the Bid Form.

3.02 UNIFORMED POLICE TRAFFIC CONTROL ALLOWANCE (ITEM 1J)

A. General

1. The Uniformed Police Traffic Control Allowance will apply only to the labor for traffic control Police officers provided by the City for the direction of traffic for this Contract per Manual on Uniform Traffic Control Devices.

B. Measurement

1. The Contractor will be reimbursed for costs for uniformed police traffic control officers for the project as invoiced by the City.

C. Payment

1. Payment for Uniformed Police Traffic Control officers provided by the City to direct traffic will be made based on the actual time on site and applicable City Ordinances. No markup will be allowed by the Contractor. The allowance price established in the Bid Form is for bidding purposes only, and the amount paid for Traffic Control may differ from this amount.
 - a. All other costs associated with uniformed police traffic control for this Contract, including traffic control devices, barriers, signage, flaggers, vehicles, equipment, personnel, and administrative costs, shall be paid under the respective replacement bid items and not under any allowance item.
 - b. Additionally, any fees associated with permits required for road opening and street closure by the Rhode Island Department of Transportation and Municipalities shall be paid under the respective replacement bid item and not under any allowance item.

3.03 FLAGGER TRAFFIC CONTROL ALLOWANCE (ITEM 1K)

A. General

1. The Flagger Traffic Control Allowance will apply only to the labor for traffic control flaggers for the direction of traffic for this Contract per Manual on Uniform Traffic Control Devices. Flaggers can only be used when permitted by the agency with jurisdiction of the roadway or when uniformed police are not available, when provided with the required advanced notification.

B. Measurement

1. The Contractor will be reimbursed for costs for traffic control flaggers for the project as invoiced.

C. Payment

1. Payment for Traffic Control Flaggers to direct traffic will be made based on the actual time on site and applicable City Ordinances. No markup will be allowed by the Contractor. The allowance price established in the Bid Form is for bidding purposes only, and the amount paid for Flagger Traffic Control may differ from this amount.
 - a. All other costs associated with traffic control for this Contract, including traffic control devices, barriers, signage, flaggers, vehicles, equipment, personnel, and administrative costs, shall be paid separately, under the respective replacement bid items and not under any allowance item.
 - b. Additionally, any fees associated with permits required for road opening or street closures by the Rhode Island Department of Transportation and Municipalities shall be paid under the respective replacement bid item and not under any allowance item.

3.04 UTILITY PROVISION ALLOWANCE (ITEM 1L)

A. General

1. The Utility Provision Allowance will apply only to reimburse the Contractor for charges imposed by utilities to protect their existing infrastructure, such as utility poles and underground mains or ducts.

B. Measurement

1. The Contractor will be reimbursed for costs invoiced by the utility.

C. Payment

1. Payment for Utility Provisions required to protect existing infrastructure based on the actual time on site and requirements of the utilities. No markup will be allowed by the Contractor. The allowance price established in the Bid Form is for bidding purposes only, and the amount paid for Utility Provisions may differ from this amount.

- a. All other costs associated with Utility Provisions for this Contract, including Contractor's vehicles, equipment, personnel, and administrative costs, shall be paid separately, under the respective replacement bid items and not under any allowance item.

3.05 PRIVATE SIDE BID ITEMS (ITEMS 2A-2D)

A. General

1. Replacement Items

- a. Trenchless or other approved means of lead water service line replacement which may include, replacement of the private side only service line (Item 2A), replacement of the private side portion of a full replacement (Item 2B), and replacing, furnishing and installing all required ball valves, adapters, reducers, fittings, flare adapters (before and after water meter), pressure reducing valves, backflow devices, expansion tanks, reduced pressure zone (RPZ) backflow preventers (if required), and appurtenances of the necessary size as required by Rhode Island Plumbing Code. Work includes testing for current and if water line is used for grounding, bypass with a temporary bonding jumper. All replacements, full or private side only, shall include mobilization (sanitary facilities, insurance, temporary construction facilities, construction vehicle parking and storage, drywall restoration, bonds, permit acquisition and fees, labor, project coordination, control of work, project signs, coordination with homeowner, property residents, tenants, and inspectors, scheduling, notifications, printing, all data and record document management, and preparation of contract required submittals); removal and disposal excess soil, spoil, rubble, lead pipes and construction debris, vegetation and similar items; stockpiling, sampling and testing; temporary and permanent sidewalk and/or yard restoration; pre and post construction photos, record documents all work required for or incidental to the satisfactory completion of the Work.
- b. Each property listed by the Owner in Appendix A, or the updated list in the database management system at the time of construction, is the target list for construction. Each property with a signed ROE agreement must have a replacement completed or, if no lead is found on either side, a test pit. If the Homeowner rejects participation in the program or does not provide entry, no test pit shall be performed.

B. Measurement

1. **(Item 2A) Lead Service Line Replacement – Private Side Only** - Measurement will be based on the number of installations completed from the curb stop to water meter within the Work Area and shall be contingent on the submission of comparable pre-construction and post-construction photographs of each installation and complete record documents, including any required permits, for each property. When a private side only replacement (i.e., from curb stop to water meter) is completed at a property, the Contractor shall be paid under Item 2A. Replacement includes scheduling all service line replacement appointments with homeowner, residents, or tenants, plumbing permit acquisition and fees, piping, coring and patching through wall or floor, drywall restoration, ball valves, relocation of meter and all appurtenances as required by the Rhode Island Plumbing Code and to make

all connections as listed in A above, installation of a temporary bonding jumper if water line is used for grounding, procurement and placement of warning tape, temporary and permanent sidewalk and/or yard restoration, flushing at the meter or hose bib, leak testing, equipment required for erosion and sediment control, and protection of existing trees. New curb boxes for private side only replacements will be paid under Item 2C as directed by the Engineer. Full Replacements will not be paid for under this item.

2. **(Item 2B) Lead Service Line Replacement – Private Side Portion of a Full Replacement** – Measurement will be based on the number of installations completed from the curb stop to water meter within the Work Area only where the public side installation is also being replaced (full replacement) and shall be contingent on the submission of comparable pre-construction and post-construction photographs of each installation and complete record documents, including any required permits, for each property. Replacement includes scheduling all service line replacement appointments with homeowner, plumbing permit acquisition and fees, piping, coring and patching through wall or floor, drywall restoration, ball valves, relocation of meter and all appurtenances as required by the Rhode Island Plumbing Code and to make all connections as listed in A above, installation of a temporary bonding jumper if water line is used for grounding, procurement and placement of warning tape, temporary and permanent sidewalk and/or yard restoration, equipment required for erosion and sediment control and protection of existing trees, flushing at the meter or hose bib, and leak testing. Full Replacements performed under this contract within the Work Area will be paid for as the sum of Item 1B and Item 2B.
3. **(Item 2C) Access Not Provided** – Measurement will be based on the number of locations where one of the following occurs:
 - a. Customer misses a scheduled and documented appointment after the Contractor mobilized for the replacement and cannot reschedule for more than 72 hours.
 - b. Customer was home but provided no reasonable work area to access the service line or water meter on the interior of the house after the Contractor mobilized for the replacement.
 - c. Improper grounding or electrical work is identified by the Contractor after mobilizing for the replacement requiring the homeowner to hire an electrician to perform electrical work before the replacement can be completed by the Contractor.

All work claimed under this Item must be documented in writing by the Contractor.

4. **(Item 2D) Reduced Pressure Zone (RPZ) Backflow Preventer** – Measurement will be based on the number of locations where an RPZ backflow preventer is installed where required by Section 15410 Interior Service Piping and Appurtenances.

C. Payment

1. Payment for **Item 2A Lead Service Line Replacement – Private Side Only** and **Item 2B Lead Service Line Replacement – Private Side Portion of a Full Replacement** shall be provided once the following components are completed:
 - a. **Administration:** Price and payment shall include, but not be limited to customer coordination, printing and distributing door hangers, notifications of service disturbance, local agency coordination and all preparation, submittal and fees associated with permits, inspections and scheduling; pipe material validation through interior inspection; pre-construction photographs; and all other preliminary documentation as required by the Contract.
 - b. **Site Preparation:** Price and payment shall include, but not be limited to temporary traffic control including traffic signage; erosion and sediment control; mobilization (sanitary facilities, insurance, temporary construction facilities, construction vehicle parking and storage, bonds, permit acquisition and fees, project coordination, control of work, project signs, scheduling, and preparation and submittal of contract required work plans); temporarily support and protection of all existing utilities and structures; all trench excavation up to depth of 5 feet (including hand, vacuum, rock and boulders and concrete road base excavation); excavation support and protection (as required); dewatering and drainage.
 - c. **Service Replacement:** Price and payment shall include, but not be limited to: temporary water for customer (as required); furnishing and installation of water service line (up to and including 2-inches in size) to limits defined in individual bid items by trenchless methods or by open-cut methods when approved by the Engineer, including pipe, all the necessary adapters, reducers, fittings and appurtenances of the necessary size required to connect to existing piping; coring through the existing foundation or wall, relocation of the meter and installation of items required to meet the Rhode Island Plumbing Code and as shown in the details in Appendix B, filling the existing meter pit with concrete, patching and waterproofing of new and abandoned penetrations; flushing at the meter or hose bib, testing of the new service line, placing the service line into service; existing lead water service line and appurtenances demolition or abandonment; procurement and placement of warning tape; backfill materials as shown in Appendix B; compaction; restoring the trench surface to grade; stockpiling. Payment for these items shall include all work required for or incidental to the satisfactory completion of the Items for which payment is not provided under other items in the Bid Form.
 - d. **Restoration on Private Side:** Price and payment shall include, but not be limited to GPS coordinates of the curb stop, and where the service line enters the house, service applications, closeout documentation including photographs; repairs and cleaning of interior work spaces; drywall restoration, patching and waterproofing of new and abandoned penetrations; loaming and seeding; temporary and permanent restoration of sidewalk, and all other testing required to complete the project as specified herein; transportation and disposal of excess excavated material, spoil, rubble, concrete, asphalt, vegetation, lead pipes and construction debris, etc. in accordance with all Federal, State and local regulations; including all labor, materials and necessary

equipment; removal of erosion and sediment control; all work required for or incidental to the satisfactory completion of the Items for which payment is not provided under other items in the Bid Form.

- e. All items, including restoration, must be fully completed prior to requesting payment in full for Bid Items 2A and 2B. A payment of 50% can be requested if a service line is installed but the restoration is not yet complete.
 - f. When a public side only replacement (i.e. from main to curb stop) is completed at a property, the Contractor shall be paid under Item 1A.
2. Payment for **Item 2C Access Not Provided** shall be full compensation for partial work described in Bid Items 2A and 2B, paragraph 1a (administration) and 1b (site preparation). Access shall be determined prior to any test pits or other excavation being performed for private side replacements. If any excavation occurs prior to access being determined, no additional payment for backfilling and restoration will be provided.
 3. Payment for **Item 2D Reduced Pressure Zone (RPZ) Backflow Preventer** shall be full compensation for all residential private side replacements when a RPZ backflow preventer is required by Section 15410 Interior Service Piping and Appurtenances. Assume RPZs required are 1-inch in size. Contractor will be paid the difference in material costs for any required larger RPZs under Item S-4 Miscellaneous Work at the Direction of the Owner. Contractor shall provide the invoices to indicate the price difference. No overhead or profit will be paid on the difference in price.

3.06 PRIVATE SIDE ITEMS – COMMERCIAL (ITEMS 3A-3C)

A. General

1. Replacement Items

- a. Commercial bid items are only for commercial-only properties. Mixed use properties with a residential component are paid for under the residential bid items. Trenchless or other approved means of lead water service line replacement which may include, replacement of the private side only service line at a commercial property (Item 3A), replacement of the private side portion of a full replacement at a commercial property (Item 3B), and replacing, furnishing and installing all required ball valves, adapters, reducers, fittings, flare adapters (before and after water meter), pressure reducing valves, backflow devices, expansion tanks, reduced pressure zone (RPZ) backflow preventers (if required), and appurtenances of the necessary size as required by Rhode Island Plumbing Code. Work includes testing for current and if water line is used for grounding, bypass with a temporary bonding jumper. All replacements, full or private side only, shall include mobilization (sanitary facilities, insurance, temporary construction facilities, construction vehicle parking and storage, drywall restoration, bonds, permit acquisition and fees, labor, project coordination, control of work, project signs, coordination with homeowner, property residents/owners, tenants, and inspectors, scheduling, notifications, printing, all data and record document management, and preparation of contract required submittals); removal and disposal

excess soil, spoil, rubble, lead pipes and construction debris, vegetation and similar items; stockpiling, sampling and testing; temporary and permanent sidewalk and/or yard restoration; all work required for or incidental to the satisfactory completion of the Work.

B. Each property listed by the Owner in Appendix A, or the updated list the database management system at the time of construction, is the target list for construction. Each property with a signed ROE agreement must have a replacement completed or, if no lead is found on either side, a test pit. If the Property Owner rejects participation in the program or does not provide entry, no test pit shall be performed. Measurement

1. **(Item 3A) Lead Service Line Replacement – Commercial – Private Side Only -**

Measurement will be based on the number of installations completed from the curb stop to water meter at a commercial property within the Work Area and shall be contingent on the submission of comparable pre-construction and post-construction photographs of each installation and complete record documents, including any required permits, for each property. When a private side only replacement (i.e., from curb stop to water meter) is completed at a commercial property, the Contractor shall be paid under Item 3A. Replacement includes scheduling all service line replacement appointments with homeowner, residents, property owners or tenants, plumbing permit acquisition and fees, piping, coring and patching through wall or floor, drywall restoration, ball valves, relocation of meter and all appurtenances as required by the Rhode Island Plumbing Code and to make all connections as listed in A above, installation of a temporary bonding jumper if water line is used for grounding, procurement and placement of warning tape, temporary and permanent sidewalk and/or yard restoration, flushing at the meter or hose bib, leak testing, equipment required for erosion and sediment control, and protection of existing trees. New curb boxes for commercial private side only replacements will be paid under Item 3C as directed by the Engineer. No full replacements will be paid for under Item 3A. An RPZ is required at all commercial locations and shall be included in Bid Item 3A.

2. **(Item 3B) Lead Service Line Replacement – Commercial – Private Side Portion of a Full Replacement -**

Measurement will be based on the number of installations completed from the curb stop to water meter at a commercial property within the Work Area only where the public side installation is also being replaced (full replacement) and shall be contingent on the submission of comparable pre-construction and post-construction photographs of each installation and complete record documents, including all required permits, for each property.

3. Replacement includes scheduling all service line replacement appointments with property owners, plumbing permit acquisition and fees, piping, coring and patching through wall or floor, drywall restoration, ball valves, relocation of meter and all appurtenances as required by the Rhode Island Plumbing Code and to make all connections as listed in A above, installation of a temporary bonding jumper if water line is used for grounding, procurement and placement of warning tape, temporary and permanent sidewalk and/or yard restoration, equipment required for erosion and sediment control and protection of existing trees, flushing at the meter or hose bib, and leak testing. Full Replacements performed under this contract within the Work Area will be paid for as the sum of Item 1B and Item 3B. An RPZ is required at all commercial locations and shall be included in Bid Item 3A.

C. Payment

1. Payment for **Item 3A Lead Service Line Replacement – Commercial – Private Side Only** and **Item 3B Lead Service Line Replacement – Commercial -- Private Side Portion of a Full** shall be provided once the following components are completed:

- a. **Administration:** Price and payment shall include, but not be limited to customer coordination, printing and distributing door hangers for notifications of service disturbance, local agency coordination, any preparation, submittal, and fees associated with permitting, inspections and scheduling; pipe material validation through interior inspection or test pit; pre-construction photographs; and all other preliminary documentation as required by the Contract.
- b. **Site Preparation:** Price and payment shall include, but not be limited to temporary traffic control including traffic signage; erosion and sediment control; mobilization (sanitary facilities, insurance, temporary construction facilities, construction vehicle parking and storage, bonds, permit acquisition and fees, project coordination, control of work, project signs, scheduling, and preparation and submittal of contract required work plans); temporarily support and protection of all existing utilities and structures; all trench excavation up to depth of 5 feet (including hand, vacuum, rock and boulders and concrete road base excavation); excavation support and protection (as required); dewatering and drainage.
- c. **Service Replacement:** Price and payment shall include, but not be limited to: temporary water for customer (as required); furnishing and installation of water service line (up to and including 2-inches in size) to limits defined in individual bid items by trenchless methods or by open-cut methods when approved by the Engineer, including pipe, all the necessary adapters, reducers, fittings and appurtenances of the necessary size required to connect to existing piping; coring through the existing foundation or wall, relocation of the meter and installation of items required to meet the Rhode Island Plumbing Code and as shown in the details in Appendix B, filling the existing meter pit with concrete, flushing at the meter or hose bib, drywall restoration, patching and waterproofing of new and abandoned penetrations; flushing, testing of the new service line, placing the service line into service; existing lead water service line and appurtenances demolition or abandonment; backfill materials as shown in Appendix B; compaction; restoring the trench surface to grade or the limits of roadway base course; stockpiling, sampling and laboratory testing of excess excavated material including, but not limited to, soil, spoil, rubble, concrete, asphalt, vegetation, etc. Payment for these items shall include all work required for or incidental to the satisfactory completion of the Items for which payment is not provided under other items in the Bid Form.
- d. **Restoration on Private Side:** Price and payment shall include, but not be limited to GPS coordinates of the curb stop, and where the service line enters the house, service application records, closeout documentation including photographs; repairs and cleaning of interior work spaces; drywall restoration, patching and waterproofing of new and abandoned penetrations; loaming and seeding; temporary and permanent restoration of sidewalk, and all other testing required to complete the project as specified herein; transportation and disposal of excess excavated material, spoil, rubble, concrete, asphalt, vegetation, lead pipes and construction debris, etc. in

accordance with all Federal, State and local regulations; including all labor, materials and necessary equipment; removal of erosion and sediment control; all work required for or incidental to the satisfactory completion of the Items for which payment is not provided under other items in the Bid Form.

- e. All items, including restoration, must be fully completed prior to requesting payment in full for Bid Items 3A and 3B. A payment of 50% can be requested if a service line is installed but the restoration is not yet complete.
 - f. When a public side only replacement (i.e. from main to curb stop) is completed at a commercial property, the Contractor shall be paid under Item 1A.
2. Payment for **Item 3C New Curb Box** shall be made in full for all private side only replacements or test pits at a commercial property (Item 3A) when a public side replacement (Item 1B) does not occur at the same location and the curb box is replaced. Payment shall also be made in full if a curb box is replaced during a test pit at a commercial property when the curb box is considered in need of replacement by the Engineer.

3.07 PITCHER FILTERS AND REPLACEMENT CARTRIDGES (ITEM 4)

A. General

1. **Pitcher Filters and Replacement Cartridges** in accordance with Specification 02663 Paragraph 2.10 shall be provided to all locations with a lead service line replacement in accordance with the following:

Single-family home = 1 pitcher filter and filter cartridges(s).

Multi-family home = 1 pitcher filter and filter cartridge(s) per unit.

Commercial = 1 pitcher filter and filter cartridge(s).

If filter cartridge lifespan is less than a 6 month supply, provide additional filter cartridges for a minimum total 6 months of filter supply.

B. Measurement

1. **Pitcher Filters and Replacement Cartridges** – Measurement will be based on the number of pitcher filters (including 6 month supply of filter cartridges) delivered to each unit per the schedule in Paragraph 3.07.A.1 at the time of replacement, including tracking delivery in leadCAST with photographic documentation.

C. Payment

1. Payment for **Pitcher Filters and Replacement Cartridges** shall be made in full for pitcher filters with 6 months of filter cartridge capacity distributed. All work associated

with ordering, storing, distributing, and tracking confirmation of distribution shall be included under this bid item.

3.08 FILL MATERIALS (ITEMS S-1A - S-1C)

A. General

1. **Imported Common Fill (Item S-1A)** - will be utilized for backfill of miscellaneous work at the direction of the Owner or Engineer. This item shall include handling, transportation placing of common fill where the native hazardous material or unsuitable material is being replaced by common fill.
2. **Crushed Stone (Item S-1B) and Flowable Fill (Item S-1C)** - will be installed on an as-needed basis for miscellaneous work at the direction of the Owner or Engineer throughout the course of the project.

B. Measurement

1. **(Item S-1A) Common Fill and (Item S-1B) Crushed Stone** - Measurement will be based on cubic yards installed as measured in place by the Engineer and as allowable per the maximum trench payment width for trenches as indicated in the Contract Documents or the actual amount placed, whichever is less, if and when directed. Under no circumstances will measurement for payment under this item be made unless specifically approved by the Engineer to replace unsuitable soil.
2. **(Item S-1C) Flowable Fill** - Measurement will be based on cubic yards installed in place as measured by the Engineer, if and when directed. Under no circumstances will measurement for payment under this item be made unless specifically approved by the Engineer. If used in trenches, the payment limits shall not exceed the trench widths as indicated in the Contract Documents or the actual amount placed, whichever is less.

C. Payment

1. Payment for **Items (Item S-1A) Imported Common Fill and (Item S-1B) Crushed Stone** shall be as follows - Price and payment shall be full compensation for, but not limited to: purchasing, transporting, testing, washing, placement, compaction, loading, unloading, reloading; including all labor, materials and necessary equipment; all work required for or incidental to the satisfactory completion of the Items for which payment is not provided under other items in the Bid Form. Backfill materials related to service line replacements shall be paid for under the respective replacement items.
2. Payment of **Item S-1C Flowable Fill** shall be as follows- Price and payment shall be full compensation for, but not limited to: purchasing, transporting, testing, pumping, placement, finishing, including all labor, materials and necessary equipment; all work required for or incidental to the satisfactory completion of the Items for which payment is not provided under other items in the Bid Form.

3.09 MISCELLANEOUS CONCRETE (ITEM S-3)

A. General

1. **Miscellaneous Concrete** - The installation of miscellaneous concrete will be performed on an as-needed basis as directed by the Engineer throughout the course of the project. Miscellaneous concrete shall contain no wire or steel reinforcement. In general, the installation of miscellaneous concrete will be undertaken whenever any construction work is required as a result of service line replacement, curb stop installation, or otherwise deemed necessary in the field.

B. Measurement

1. **(Item S-3) Miscellaneous Concrete** - Measurement will be based on cubic yards installed as measured by the Engineer, if and when directed and as not included already in another bid item.

C. Payment

1. Payment for **Item S-3 Miscellaneous Concrete** shall be as follows - Price and payment shall be full compensation for, but not limited to: formwork, purchasing and transporting all concrete used for the Work; all labor, material (including expansion joints) and equipment required to properly place, prepare, finish and protect the concrete, concrete testing; and all other incidentals to the Work for which separate payment is not provided under other items in the Bid Form. Concrete shown on the Details in Appendix B or as listed in other bid items will not be paid for under this bid item.

3.10 MISCELLANEOUS WORK AT DIRECTION OF THE OWNER (ITEM S-4)

A. General

1. This item is intended to pay the Contractor for performing emergency repairs of water, sewer utilities and services for correction of any unforeseen conditions as discovered during the performance of the work as directed and approved by the Engineer or Owner. Utility repairs resulting from activities related to the Contractor's convenience or negligence will not be paid for under this item and will be paid for by the Contractor at no additional cost to the Owner.

B. Measurement

1. **(Item S-4) Miscellaneous Work at Direction of the Owner** - Measurement shall be based on the Contractor's time and material costs for performing emergency repairs of water and sewer utilities, as approved by Engineer. Contractor shall notify the Engineer's representative prior to proceeding with time and material work and shall provide time and material ticket to the Engineer's representative the day the work is performed. No time and material tickets will be accepted if not provided within 48 hours of work being performed.

C. Payment

1. Payment for **Item S-4 Miscellaneous Work at Direction of the Owner** will be made on the actual amount of work done approved and measured by the Engineer. Emergency repairs of water and sewer utilities shall include but not be limited labor, materials and equipment required for repair and replacement of water and sewer utilities and services utilizing the methods allowed herein and shall be full compensation for all work related to cutting existing pavement and excavation; excavation support and protection (as required); dewatering and drainage; repair of utility pipelines as directed by the Engineer; backfilling with native soil; compaction; restoring the trench surface to grade; restoring all physical features to grade including furnishing, installing, placing, compacting and sweeping; dense-graded base course, formwork, curing, concrete sidewalks, driveway aprons, concrete curb, initial paving, roadway concrete subbase, resetting or replacing of existing slate sidewalks and granite curbs, asphalt or concrete stamping, resetting or replacement of brick or rock pavers, pavement markings; painting, patching; cleaning, chlorinating; and all other incidentals to the satisfactory completion of this Item.
2. Services shall be based on the Contractor's time and material costs for performing the work as approved by Engineer.
3. Only work authorized in writing by the Engineer will be allowed to be reimbursed under this item.

END OF SECTION

SECTION 01026
APPLICATION FOR PAYMENT

PART 1 GENERAL

1.01 REQUIREMENTS INCLUDED

- A. Submit Applications for Payment to the Engineer in accordance with the schedule established by Conditions of the Contract and Agreement between Owner and Contractor.
- B. The accepted Schedule of Values, Section 01370, shall be used as the basis for the Contractor's Application for Payment.

1.02 RELATED WORK

- A. Standard General Conditions of the Construction Contract are included in Section 00 72 00.
- B. Schedule of Values are included in Section 01370.
- C. Contract Closeout is included in Section 01700.

1.03 SUBMITTALS

- A. Submit, in accordance with Section 01300, applications typed on forms provided by the Owner, Application for Payment, with itemized data typed on 8-1/2-in by 11-in or 8-1/2-in by 14-in white paper continuation sheets.
- B. Provide itemized data on a continuation sheet.
 - 1. Format, schedules, line items, and values: Those of the Schedule of Values accepted by the Engineer.

1.04 PREPARATION OF APPLICATION FOR EACH PROGRESS PAYMENT

- A. Application Form
 - 1. Fill in the required information, including that for Change Orders executed prior to the date of submittal of application.
 - 2. Fill in the summary of dollar values to agree with respective totals indicated on continuation sheets.
 - 3. Execute certification with the signature of a responsible officer of Contract firm.
- B. Continuation Sheets
 - 1. Fill in the total list of all scheduled component items of Work, with item number and scheduled dollar value for each item.
 - 2. Fill in dollar value in each column for each scheduled line item when work has been performed or products stored.
 - a. Round off values to the nearest dollar, or as specified for Schedule of Values.

3. List each Change Order executed prior to the date of submission, at the end of the continuation sheets.
 - a. List by Change Order Number and description, as for an original component item of work.
4. To receive approval for payment on component material stored on site, submit copies of the original paid invoices with the application for payment.

1.05 SUBSTANTIATING DATA FOR PROGRESS PAYMENTS

- A. The following must be provided before the property location is listed on the pay application. Full payment will not be provided until these items are submitted in accordance with Section 01720.
 1. Water service applications
 2. Traffic engineering permits
 3. Road opening permits
 4. Plumbing permits
 5. Pre-/Post-construction photographic documentation
- B. Submit suitable information, with a cover letter identifying.
 1. Project name and location.
 2. Application number and date
 3. Certified payroll
 4. Detailed list of enclosures with property addresses and type of replacement performed
 5. For stored products:
 - a. Item number and identification as shown on the application
 - b. Description of specific material
- C. Submit one copy of data and cover letter for each copy of the application.
- D. As a prerequisite for payment, submit a "Surety Acknowledgement of Payment Request" letter showing the amount of progress payment which the Contractor is requesting.
- E. Quantities in pay applications will be checked with the information stored in the project data management system. No payment will be made to Contractor unless all record information for every installed service line matches between the project data management system database, the Contractor's pay application, and the Engineer's measured quantities.

1.06 PREPARATION OF APPLICATION FOR FINAL PAYMENT

- A. Fill in the Application form as specified for progress payments.

- B. Use a continuation sheet for presenting the final statement of accounting as specified in Section 01700.
- C. Submit all Project Record Documents in accordance with Section 01720.

1.07 SUBMITTAL PROCEDURE

- A. Submit Applications for Payment to the Engineer at times stipulated in the Agreement.
- B. Number: Five copies of each Application.
- C. When the Engineer finds Application properly completed and correct, he/she will transmit certificate for payment to Owner, with a copy to Contractor.

PART 2 PRODUCTS (NOT USED)

PART 3 EXECUTION (NOT USED)

END OF SECTION

SECTION 01038
REQUESTS FOR INFORMATION

PART 1 GENERAL

1.01 DESCRIPTION OF REQUIREMENTS

- A. This Section specifies the general methods and requirements of Requests for Information (RFIs).

1.02 RELATED WORK

- A. Additional requirements may be specified in the General Conditions.
- B. Submittals are included in Section 01300.
- C. Special Provisions are included in Section 01170.
- D. Project Record Documents are included in Section 01720.

1.03 REQUESTS FOR INFORMATION

- A. When the Contractor believes that additional information or clarification of a contract requirement is needed, Contractor may initiate a Request for Information via the Kahua software.
- B. RFIs may relate to Technical matters or Administrative matters. The RFI process shall be limited to the clarification of technical and/or administrative matters. While the response to an RFI might lead to a change in the contract scope, cost or time, RFIs are not a substitute for the notification requirements stipulated in the General Conditions.
- C. A response to an RFI may authorize minor changes to the contract consistent with the terms of the contract related to the responsibilities and limitations of authority of the Engineer.
- D. A response to an RFI is not an authorization to perform any additional work that would require a change order or written amendment to the contract. If the Contractor believes the response to an RFI requires a change to the contract, Contractor shall promptly provide written notice to the Owner and Engineer in accordance with the General Conditions.
- E. RFIs are not a substitute for the Submittals process specified elsewhere.

PART 2 PRODUCTS – NOT USED

PART 3 EXECUTION

3.01 ORIGINATION

- A. Originate RFIs using the form appended to this Section.
 - 1. RFIs shall be numbered consecutively. In the event that an answered RFI results in a follow-up inquiry, the follow-up shall maintain the same number as the original, appended with a suffix.

2. Include Specification Section(s), Contract Maps(s), or detail(s) for which information is requested.
 3. Attach drawings, sketches, photographs or other relevant information.
 4. If the question concerns an interpretation of the Contract Documents, enter the Contractor's interpretation.
 5. Indicate the date by which the Contractor requests a reply.
 6. Sign the upper portion of the form.
- B. RFIs may not be submitted by subcontractors or suppliers. When a subcontractor or supplier generates a request for information or clarification to the Contractor, incorporate such requests into the required format, assign the next number, and sign.
- C. Maintain a log of all RFIs including the date originated, date delivered, and date answered.

3.02 PROCESSING

- A. Submit all RFIs to the Engineer for processing.
- B. Technical RFIs will generally be reviewed and answered by the respective discipline engineer or architect.
- C. Administrative RFIs will generally be reviewed and answered by the Engineer in consultation with the Owner.
- D. The Engineer will generally respond to RFIs within fourteen calendar days of receipt – depending on the complexity of the inquiry.

3.03 RESPONSES

- A. If the RFI contains sufficient clarity, the Engineer will insert a response in the lower portion of the RFI form, sign and date the response; and, return the completed form to the Contractor.
- B. If the RFI does not contain sufficient clarity, the Engineer may request additional information from the Contractor.
- C. The Engineer will distribute copies to the Owner and project files.
- D. The Engineer will maintain a log of all RFIs including the date received, and date returned to Contractor.

3.04 RECORD INFORMATION

- A. Include all clarifications obtained through the RFI process into the record information in accordance with Section 01720.

END OF SECTION
(Standard RFI Form Follows)

Request for Information

Project Name:		
Contract Number.:		
Contractor:	RFI No.:	
	Date:	
Subject:		
Spec Section:	Drawing/Map:	Detail:

QUESTION:	
<p>If the above question concerns an interpretation of the Contract Documents, the Contractor's interpretation is:</p>	
Please Respond by This Date:	
Submitted by Contractor:	Date:
Received by (CDM Smith):	Date:

RESPONSE:	
By:	Date:
Distribution: Contractor, Owner, File, Field, RFI Notebook	

SECTION 01045
CUTTING, CORING AND PATCHING

PART 1 GENERAL

1.01 SCOPE OF WORK

- A. This Section covers the cutting, coring, rough and finished patching of holes and openings. Holes and opening made in existing construction, or in parts of new construction. Procedures for cutting and patching will be the same for either condition.
- B. All cutting, coring, and rough patching shall be performed by the Contractor. Finish patching shall be the responsibility of the Contractor.
- C. Provide all cutting, fitting and patching, including attendant excavation and backfill, required to complete the work or to:
 - 1. Make its several parts fit together properly.
 - 2. Uncover portions of the work to provide for installation of ill-timed or improperly scheduled work.
 - 3. Remove and replace defective work.
 - 4. Remove and replace work not conforming to requirements of Contract Documents.
 - 5. Provide penetrations of structural surfaces and materials for installation of piping.
 - 6. Provide penetrations of non-structural surfaces for installation of piping. The determination of what is a nonstructural surface or material shall be made by the Engineer.
 - 7. Remove, install, or relocate materials.

1.02 RELATED WORK

- A. Summary of Work is included in Section 01010.
- B. Pipe penetrations and assemblies are included in Section 01180.
- C. Site work is included in Division 02.
- D. Concrete is included in Division 03.

1.03 SUBMITTALS

- A. Submit, in accordance with Section 01300, a written request prior to executing any cutting or alteration which is not shown on details which affects or requires:
 - 1. Work of the Owner or "Customer."

- B. The request shall include:
 - 1. Identification of the project.
 - 2. Effect on work of Owner or any separate contractor, or on the structural or weatherproof integrity of the project.
 - 3. Description of proposed work:
 - a. Method and extent of cutting, patching, alteration, or excavation.
 - b. Trades who will execute the work.
 - c. Products proposed to be used.
 - d. The extent of refinishing to be done.
 - 4. Confirmation of coordination with any separate contractor whose work will be affected.
 - 5. Related shutdown requests if required to do the work.

PART 2 PRODUCTS

2.01 MATERIALS

- A. Comply with specifications and standards for each specific product involved. Where there is no equivalent specification, notify the Engineer who will provide a specification for the materials to be used.
- B. Grout for patching shall be as specified in Section 01180.
- C. Materials for finish patching shall be equal to those of adjacent construction. Where existing materials are no longer available, use materials with equivalent properties and that will provide the same appearance. The materials are to be approved by the Engineer prior to their use.

PART 3 EXECUTION

3.01 INSPECTION

- A. Inspect existing conditions, including elements subject to damage or movement during cutting and patching.
- B. After uncovering work, inspect conditions affecting installation of products, or performance of work.
- C. Report unsatisfactory or questionable conditions to the Engineer; do not proceed with work until the Engineer has provided further instructions.

3.02 PREPARATION

- A. Provide adequate temporary support as necessary to assure structural value or integrity of the affected portion of work.
- B. Protect surrounding materials and equipment prior to starting work.
- C. Contain and control cooling liquids and slurry produced by the cutting and coring operations.

- D. When the cutting or coring results in the structure or equipment being exposed to the environment, the Contractor shall provide adequate weather protection.
- E. Provide dewatering for excavation work in accordance with Section 02140.

3.03 PERFORMANCE

- A. Execute cutting and demolition by methods which will prevent damage to other work and will provide proper surfaces to receive installation.
- B. Execute excavating and backfilling by methods which will prevent settlement or damage to other work. When excavating in close proximity to piping or other items subject to damage, use hand excavation.
- C. All equipment and workplace safety shall conform to OSHA standards and specifications pertaining to plugs, noise and fume pollution, wiring and maintenance.
- D. Execute fitting and adjustment of products to provide a finished installation to comply with specified products, functions, tolerances and finishes.
- E. Restore work which has been cut or removed; install new products to provide completed work in accordance with the requirements of Contract Documents.
- F. Refinish entire surfaces as necessary to provide an even finish to match adjacent finishes:
- G. Remove rubble and excess patching materials from the premises.

3.04 CORING

- A. All coring shall be performed in such a manner as to limit the extent of patching. Locate the rebar before coring to minimize cut-throughs.
- B. Coring shall be performed with an approved non-impact rotary tool with diamond core drills.
- C. Size of holes shall be suitable for pipe, packing, patching, waterproofing or mechanical seals to be installed.
- D. All holes cut through concrete, masonry and rock walls, slabs or arches shall be core drilled unless otherwise approved. All work shall be performed by personnel skilled in this type of work.
- E. If holes are cored through floor slabs, they shall be drilled from below where possible. If holes are drilled from above, provide protection and containment below the area being drilled to catch the plug and contain liquid and slurry.

3.05 CUTTING

- A. All cutting shall be performed in such a manner as to limit the extent of patching.
- B. Cutting shall be performed with a concrete saw, and diamond saw blades of the proper size.

- C. Provide for control of slurry generated by sawing operation on both sides of the wall and from below if cutting a floor.
- D. When cutting a reinforced concrete wall or floor, the cutting shall be done so as not to damage the bond between the concrete and reinforcing steel left in structure. Cut shall be made so that steel neither protrudes or is recessed from the face of the cut.
- E. Adequate bracing of the area to be cut shall be installed prior to the start of cutting. Check area during sawing operations for partial cracking and provide additional bracing as required to prevent a partial release of the cut area during sawing operations.
- F. Provide equipment of adequate size to remove cut panel.
- G. Saw cut concrete and masonry prior to breaking out sections.
- H. Install work at such time as to require the minimum amount of cutting and patching.

3.06 PROTECTION

- A. Provide devices and methods to protect other portions of the project from damage.
- B. Provide protection from elements for that portion of the project which may be exposed by cutting and patching work.
- C. Maintain excavations free from water.

3.07 PATCHING

- A. Rough patching shall be such as to bring the cut or cored area flush with existing construction unless otherwise shown.
- B. Finish patching shall match existing surfaces as approved.
- C. Patching shall be of the same kind and quality of material as was removed.
- D. The completed patching work shall restore the surface to its original appearance or better.
- E. Patching of waterproofed surfaces shall render the area of the patching completely waterproofed to include the joint between the existing material and the patch.
- F. Slurry or tailings resulting from coring or cutting operations shall be contained and vacuumed or otherwise removed from the area following drilling or cut.
- G. Equipment shall be protected against mechanical and water damage during cutting and patching. Provide protective covers or use other means to protect equipment that is at risk of damage from the cutting and patching.
- H. Provide protection for existing equipment, utilities and critical areas against water or other damage caused by drilling operation.

END OF SECTION

SECTION 01046
CONTROL OF WORK

PART 1 GENERAL

1.01 CONSTRUCTION EQUIPMENT

- A. Furnish equipment which will be efficient, appropriate and large enough to secure a satisfactory quality of work and a rate of progress which will ensure the completion of the work within the Contract Time. If at any time such plan appears to the Engineer to be inefficient, inappropriate or insufficient for securing the quality of work required or for producing the rate of progress aforesaid, he/she may order the Contractor to increase the efficiency, change the character or increase the equipment and the Contractor shall conform to such order. Failure of the Engineer to give such order shall in no way relieve the Contractor of his/her obligations to secure the quality of the work and rate of progress required.

1.02 PRIVATE LAND

- A. Do not enter or occupy private land outside of easements, except by written permission of the Customer. See requirements for the Right of Entry (ROE) and Release Form for Lead Service Line Replacement in Section 01170.

1.03 EXISTING WATER DISTRIBUTION SYSTEM

- A. If approved by Engineer and Owner, Notify the Owner, Engineer and fire department 72 hours in advance of any requirement for isolating a section of water mains, so that water customers may be notified, and the necessary arrangements may be made, which may include a fire watch by the fire department.
- B. The Owner will perform all shutdowns. The Contractor shall not turn any valves in the system unless approved by the Owner in writing.
- C. If water or fire services for a single Customer or several customers are to be interrupted for an extended period (i.e., longer than 8 hours), provide temporary water service to all water users as required through new temporary piping and hoses. Temporary piping and hoses shall meet NSF 61 standards for potable water; hoses shall be connected to the water meter at every impacted location, providing potable water. The inconvenience to water users shall be kept at a minimum.
- D. The Owner and Engineer reserve the right to review and approve the Contractor's proposed use of any temporary bypass piping and hoses. If for any reason an existing fire hydrant is taken out of service, a temporary hydrant must be provided and the City Fire Department must be notified immediately. The safety and integrity of the water system are of prime importance. All work shall be completed with all water mains live and in service as specified in Section 02663 unless necessitated by special circumstances that are reviewed and approved by the Engineer.
- E. If temporary hoses are needed and only if approved by the Engineer, the Contractor is required to submit a daily log of all addresses where temporary services have been installed or removed. All temporary hoses shall be ¾ -inch minimum diameter and shall be capable of withstanding at least 1.5 times the normal working pressure. All hoses that are to supply potable water to buildings are to be NSF 61 and/or FDA approved for contact with drinking water. Hoses shall be installed in a safe location, shall not be considered a tripping hazard by the Owner or

Engineer and shall not block any walkways, driveways, or access to homes. During the winter months, freeze protection shall be provided.

- F. Construction Sequence and Special Work Requirements are as specified in Section 01014.

1.04 WATER SERVICE LINE LOCATIONS

- A. The Contractor shall bear full responsibility for obtaining all locations of underground structures and utilities (including existing water services, drain lines, gas, cable, fiber optic, sewers, etc.). The location of water service line as provided by the Owner will be determined from service cards and service maps that represent the existing conditions at the time of the original installation and not guaranteed to be accurate or reflect current conditions.
- B. All mark outs of utilities shall be considered by the Contractor as the approximate location for the purpose of damage prevention. The Contractor shall be solely responsible for employing prudent techniques to determine the precise position of the water distribution system underground facility for connection purposes. The cost for this work shall be included in Bid Items 1A, 1B, 2A, 2B, 3A or 3B, where applicable. The Contractor will not be compensated for any additional costs to locate the water line if the water department markout/records are not accurate.
- C. New service line replacement piping shall be located substantially close to the existing locations of the lead service lines; however, the Engineer reserves the right to make such modifications in locations as may be found desirable to avoid interference with existing structures or utilities or for other reasons. Where fittings or connections are noted in details, such notation is for the Contractor's convenience and does not relieve him/her from laying and jointing different or additional items where required.

1.05 TRENCHLESS

- A. All new water service lines shall be constructed via trenchless methods to minimize private property restoration unless otherwise approved by the Engineer for specific properties.
- B. Trenchless installation shall include but not be limited to Utility Impact Molding or Pipe Pulling.
 - 1. All trenchless work shall be done at a minimum of 4-feet below surface unless the existing water service line is shallower.
 - 2. Make every effort to minimize impact to existing underground utilities and Contractor shall report any utilities struck or damaged to Owner and Engineer.
 - 3. Launch pits shall be large enough to accommodate the operator and tools for alignment. All excavation specifications shall be followed in the construction of the launch and recovery pits.
 - 4. If a "tool" is lost, it shall be recovered as soon as possible at the Contractor's expense.
- C. Obtain approval from the Engineer to install the entire new service line, or portions of the new line, utilizing a method other than a trenchless method. If a service line or portion of the new service line is installed via open-cut trench due to site conditions, failure of trenchless methods, or other approved reasons, payment shall be under the same bid item as if the service line was installed via trenchless methods, including all restoration requirements as specified.

1.06 OPEN EXCAVATION

- A. If open excavations are used, adequate safeguarding shall include but not limited to temporary barricades, caution signs, lights and other means to prevent accidents to persons and damage to property. The Contractor shall, at his/her own expense, provide suitable and safe bridges and other crossings for accommodating travel by pedestrians and workers. Bridges provided for access during construction shall be removed when no longer required. The length or size of excavation will be controlled by the particular surrounding conditions but shall always be confined to the limits prescribed by the Engineer. If the excavation becomes a hazard, or if it excessively restricts traffic at any point, the Engineer may require special construction procedures such as limiting the length of the open trench, prohibiting stacking excavated material in the street and requiring that the trench shall not remain open overnight.
- B. Take precautions to prevent injury to the public due to open trenches. All trenches, excavated material, equipment, or other obstacles which could be dangerous to the public shall be well lighted at night. Accordingly, unattended trenches must be covered, barricaded or backfilled.
- C. Where the use of road plates is approved for temporarily securing open excavations in roads, plates shall be spiked and recessed to be flush with the surrounding pavement.

1.07 TEST PITS

- A. If the public and private sides of the service line are both found to be a material other than lead, backfill the excavation and perform the surface restoration in accordance with Section 02221. All restoration shall be completed to the satisfaction of the Engineer. All work associated with the excavation, backfill, and restoration for a service line that is found to not be lead on either side shall be considered a test pit and paid for under Bid Item 1C. See Section 01170 for minimum test pit dimensions.
- B. If a test pit is performed at a location not indicated in Appendix A or without the direction of the Owner and Engineer, the test pit will be for the convenience of the Contractor and the Contractor will not be paid under Bid Item 1C.

1.08 MAINTENANCE OF TRAFFIC

- A. Traffic on the affected roads and streets shall be maintained at all times under responsibility of the Contractor. Maintenance of traffic provisions shall be approved in writing by the Engineer, Owner, and the jurisdiction Police Department. All maintenance of traffic and road closures shall be in accordance with all Providence Department of Public Works permits. Work on State roads also shall be approved in writing by the Rhode Island Department of Transportation (RIDOT). All traffic control devices shall be in accordance with the Manual on Uniform Traffic Control Devices, latest issue.
- B. Unless permission to close a street is received in writing from the Police Department, Engineer and Owner, all construction equipment and excavated material shall be placed so that vehicular and pedestrian traffic may be maintained at all times. If the Contractor's operations cause traffic hazards, he/she shall repair the road surface, provide temporary ways, erect wheel guards or fences, or take other measures for safety satisfactory to the Engineer.
- C. Detours around construction will be subject to permit approval, and approval of the Engineer and Owner. Where detours are permitted, provide all necessary barricades and signs as required to divert the flow of traffic. Provide expedited construction when traffic is detoured.

- D. The Contractor shall be fully responsible for damage or injuries whether or not traffic control officers have been provided.
- E. See Section 01576 for additional requirements for traffic control.

1.09 CARE AND PROTECTION OF PROPERTY

- A. The Contractor shall be responsible for the preservation of all public and private property and shall use every precaution necessary to prevent damage thereto. If any direct or indirect damage is done to public or private property by or on account of any act, omission, neglect, or misconduct in the execution of the work on the part of the Contractor, such property shall be restored by the Contractor, at his/her expense, to a condition similar or equal to that existing before the damage was done, or he/she shall make good the damage in another manner acceptable to the Engineer.

1.10 PROTECTION AND RELOCATION OF EXISTING STRUCTURES AND UTILITIES

- A. Assume full responsibility for the protection of all buildings, structures, and utilities, public or private, including poles, signs, services to buildings, utilities in the street, gas pipes, water pipes, hydrants, sewers, drains, and electric and telephone cables. Carefully support and protect all such structures and utilities from injury of any kind. All damage resulting from the Contractor's operations shall be repaired at the Contractor's expense. Establish the location and extent of all existing utilities before the commencement of excavation by calling 811 Dig Safe RI and obtaining a dig ticket. Notify all utility companies and Dig Safe in writing at least 72 hours (excluding Saturdays, Sundays and Legal holidays) before excavating or otherwise affecting utilities in any public way or easement. Only Providence Water Supply Board personnel may operate Providence Water Supply Board valves.
- B. Services to buildings shall be maintained, and all costs or charges resulting from damage thereto shall be paid by the Contractor at no additional cost to the Owner.
- C. Protection and temporary removal and replacement of existing utilities and structures as described in this Section shall be a part of the work under the Contract at no additional cost to the Owner.
- D. Service lines installation shall be worked around all existing underground utilities. Make every effort to install service line in such manner as to avoid utility conflicts. If in the opinion of the Engineer, permanent relocation of a utility is required, the Engineer may direct the Contractor, in writing, to perform the work. Work so ordered will be paid for at the Contract unit prices, if applicable, or as extra work under Article 11 of the General Conditions. If relocation of a privately-owned utility is required, the Owner will notify the Utility to perform the work as expeditiously as possible. The Contractor shall fully cooperate with the Owner and Utility and shall have no claim for the delay due to such relocation.
- E. Coordinate the removal and replacement of traffic loops and signals, as required for the performance of the work, at no additional cost to the Owner.
- F. The Contractor shall bear full responsibility, for obtaining all locations of underground structures and utilities (including existing water services, drain lines, gas, electric, telecommunication, and sewers). All utilities are considered unknown and shall not be considered as differing site conditions.

1.11 WATER FOR CONSTRUCTION PURPOSES

- A. In locations where public water is available, the Contractor may be allowed to use water for construction purposes without charge.
- B. The express approval of the Owner shall be obtained before water is used. Waste of water shall be sufficient cause for withdrawing the privilege of unrestricted use. Hydrants or valves shall only be operated under the supervision of the Owner's personnel.
- C. If water restrictions are in force, the Contractor shall supply his/her own source of water which shall be acceptable to the Engineer.
- D. When drawing water for construction purposes, use caution at all times to prevent potential contamination of the Owner's water distribution system. Hydrant connections will require a backflow preventer and meter suitably installed to the satisfaction of the Engineer and Owner.
- E. Coordinate with the Owner for the opening and closing of hydrants. Hydrants shall be operated under the supervision of the Owner. All hydrants must be opened and closed SLOWLY to prevent damage.
- F. Supply a working reduced pressure backflow preventer and flow meter on each hydrant utilized during construction. The Contractor shall be responsible for providing all hoses and special fittings needed for utilizing the Owner's water supply. During the shop drawing process, submit information on the hydrant meters and backflow preventer intended for use for construction purposes.
- G. At the end of construction, furnish a tabulation of the total gallons of water utilized during the course of the contract.
- H. The Contractor will be responsible for all damage caused by water which passes through the hydrant meter, whether it is used or wasted. If damage does occur, Contractor shall incur all responsibility and costs for repair of any damage and returning the site to its original condition.

1.12 MAINTENANCE OF FLOW

- A. The Contractor shall at his/her own cost, provide for the flow of drains and watercourses interrupted during the progress of the work, and shall immediately cart away and remove all offensive matter. The entire procedure of maintaining existing flow shall be fully discussed with the Engineer well in advance of the interruption of any flow.

1.13 COOPERATION WITHIN THIS CONTRACT

- A. All firms or persons authorized to perform any work under this Contract shall cooperate with the Contractor and his/her Subcontractors or trades and shall assist in incorporating the work of other trades where necessary or required.

1.14 CLEANUP AND DISPOSAL OF EXCESS MATERIAL

- A. During the course of the work, keep the site of Contractor operations in as clean and neat a condition as is possible. Contractor shall dispose of all residue resulting from the construction work and, at the conclusion of the work, Contractor shall remove and haul away any surplus excavation, broken pavement, lumber, equipment, temporary structures and any other refuse

remaining from the construction operations and shall leave the entire site of the work in a neat and orderly condition.

- B. Immediately remove from the site and legally dispose of all service lines and appurtenances replaced under this Contract. At no time shall these materials be stacked along the trench.
- C. In order to prevent environmental pollution arising from the construction activities related to the performance of this Contract, the Contractor and his/her subcontractors shall comply with all applicable Federal, State and local laws and regulations concerning waste material disposal, as well as the specific requirements stated in this Section and elsewhere in the Specifications.
- D. The Contractor is advised that the disposal of excess excavated material in wetlands, stream corridors, and floodplains is strictly prohibited even if the permission of the Owner is obtained. Any violation of this restriction by the Contractor or any person employed by him/her will be brought to the immediate attention of the responsible regulatory agencies, with a request that appropriate action is taken against the offending parties. Therefore, the Contractor will be required to remove the fill at his/her own expense and restore the area impacted.
- E. Dispose of all surplus excavated soil material, including construction debris, boulders, broken pavement, demolished pipe, and other non-soil material.

1.15 RESTORATION

- A. Restore all areas to conditions that existed prior to construction. Restoration outside of the pipe trench limits required as a result of the construction activities shall be at the Contractor's own expense. Restoration within the pipe trench limits shall be included in the appropriate bid items as required in Section 01025. Restoration, including restoration on private property, as specified in Sections 01025 (Measurement and Payment), Section 02576 (Pavement Repair and Resurfacing), and Section (02930) Loaming and Seeding.
- B. Existing public and private driveways and sidewalks disturbed by the construction shall be replaced to the limits and thicknesses existing prior to construction and as specified in Section 02576 (Pavement Repair and Resurfacing), and Section (02930) Loaming and Seeding.
- C. Existing signs, lampposts and mailboxes which are damaged by the Contractor or removed by the Contractor during the course of the work shall be reinstalled in a vertical position at the same location from which they were removed. Damaged items shall be replaced with an item equal to or better than the damaged items. A concrete anchor shall be provided as necessary, at no additional cost, to ensure a rigid alignment. Care shall be exercised in the reinstallation of all items to prevent damage to the newly installed pipelines.
- D. Existing concrete, bituminous, timber, granite or other material curbing shall be protected. If necessary, curbing shall be removed and replaced after backfilling. Curbing which is damaged during construction shall be replaced with curbing of equal quality and dimension. Granite curbing removed and reset shall conform to the local municipality's standards. Joints between sections shall be expansion type as required. Bituminous berms shall conform to the Owner's Standards.
- E. Restoration of any areas on private property disturbed by construction is as specified in Sections 02576 Pavement Repair and Resurfacing, and 02930 Loaming and Seeding.

1.16 PIPE TRENCH WIDTHS

- A. Pipe trench widths referred to herein are the distances separating the vertical planes between which the pipe is to be laid. Maximum trench payment widths for open cut installations are provided on the Details included in Appendix B. In computing the amount of excavation below 5-feet for payment under Item 1F, trench width shall be as specified for maximum trench width.
- B. Where trenchless installation methods are used, the excavation area shall be only what is needed for workers and equipment to perform the installation. Maximum access pit payment sizes for trenchless installations shall be 4 ft by 6 ft in the roadway and 4 ft by 4 ft at the curb stop or anywhere on private property.
- C. Trench and excavation limits are applicable for determining additional payment related to excavation, backfill, and restoration outside of the items included in the replacement bid items.

1.17 SERVICE LINE TRENCH DEPTHS

- A. The top of the trench shall be the ground elevation. The bottom of the trench shall be the invert elevation of the pipe and minimum 6-inches of bedding material as specified in Section 02230 Paragraph 2.01.E.
- B. In computing the amount of excavation below 5-feet for payment under Item 1F, trench depth shall be depth below 5-feet of excavation and trench width shall be as described in Paragraph 1.16.

END OF SECTION

SECTION 01110
ENVIRONMENTAL PROTECTION PROCEDURES

PART 1 - GENERAL

1.1 RELATED DOCUMENTS

- A. Drawings and general provisions of the Contract, including General and Special Conditions and Division 01 Specification Sections, apply to this Section.

1.2 SUMMARY

- A. Furnish all labor, materials and equipment and perform all work required for the prevention of environmental pollution in conformance with applicable laws and regulations, during and as the result of construction operations under this Contract. For the purpose of this Section, environmental pollution is defined as the presence of chemical, physical, or biological elements or agents which adversely affect human health or welfare; unfavorably alter ecological balances of importance to human life; affect other species of importance to man; or degrade the utility of the environment for aesthetic and/or recreational purposes.
- B. The control of environmental pollution requires consideration of air, water and land, and involves management of noise and solid waste, as well as other pollutants.
- C. Schedule and conduct all work in a manner that will minimize the erosion of soils in the area of the work. Provide erosion control measures such as diversion channels, sedimentation or filtration systems, berms, seeding, mulching or other special surface treatments as are required to prevent silting and muddying of streams, rivers, impoundments, lakes, etc. All erosion control measures shall be in place in an area prior to any construction activity in that area. Specific requirements for erosion and sedimentation controls are specified in Section 02270 "Sedimentation and Erosion Controls".
- D. This Section is intended to ensure that construction is achieved with a minimum of disturbance to the existing ecological balance between a water resource and its surroundings. These are general guidelines. It is the Contractor's responsibility to determine the specific construction techniques to meet these guidelines.
- E. All phases of sedimentation and erosion control shall comply with and be subject to the approval of the Engineer and Owner.
- F. Section includes:
 - 1. Prohibited Activities.
 - 2. Erosion control.
 - 3. Protection of streams and surface waters.
 - 4. Protection of land resources.
 - 5. Protection of air quality.
 - 6. Noise control.
 - 7. Maintenance of Pollution Control Facilities During Construction.

1.3 QUALITY CONTROL

- A. Comply with all applicable Federal, State and local laws and regulations concerning environmental pollution control and abatement.
- B. Engineer will notify the Contractor in writing of any non-compliance with the foregoing provisions or of any environmentally objectionable acts and corrective action to be taken. State or local agencies responsible for verification of certain aspects of the environmental protection requirements shall notify the Contractor in writing, through the Engineer, of any non-compliance with State or local requirements. After receipt of such notice from the Engineer or from the regulatory agency through the Engineer, immediately take corrective action. Such notice, when delivered to the Contractor or his authorized representative at the site of the work, shall be deemed sufficient for the purpose. If the Contractor fails or refuses to comply promptly, the Owner may issue an order stopping all or part of the work until satisfactory corrective action has been taken. No part of the time lost due to any such stop orders shall be made the subject of a claim for extension of time or for excess costs or damages by the Contractor unless it is later determined that the Contractor was in compliance.

1.4 PREINSTALLATION MEETINGS

- A. Prior to commencement of the work, meet with the Engineer and Owner to develop mutual understandings relative to compliance with these provisions and administration of the environmental pollution control program.

1.5 IMPLEMENTATION

- A. Remove temporary environmental control features, when approved by the Engineer and incorporate permanent control features into the project at the earliest practicable time.

PART 2 - PRODUCTS (NOT USED)

PART 3 - EXECUTION

3.1 PROHIBITED ACTIVITIES

- A. Do not use procedures, activities, or operations that may adversely impact the natural environment or the public health and safety. Prohibited construction procedures, activities, or operations include but are not limited to:
 - 1. Dumping or disposal of spoil materials, discharging of solid waste deleterious to any stream corridors, any wetlands, any surface waters, or on any public or private property not specified for said purpose.
 - 2. Disposal of debris in any stream corridors, any wetlands, any surface water, or at unspecified locations.
 - 3. Storing construction equipment and vehicles and/or stockpiling construction materials at locations not previously specified and approved by the Owner for said purposes.

4. Dumping, disposing, or stockpiling of any material at any location within the City of Providence without approval.

3.2 EROSION CONTROL

- A. Provide positive means of erosion control such as shallow ditches around construction to carry off surface water. Erosion control measures, such as siltation basins, hay check dams, mulching, jute netting and other equivalent techniques, shall be used as appropriate. Offsite surface water shall be diverted around the site, to a downstream channel ahead of siltation barriers. Flow of surface water into excavated areas shall be prevented. Ditches around construction area shall also be used to carry away water resulting from dewatering of excavated areas. All erosion control measures shall be in place in an area prior to construction activity in that area. Specific requirements for erosion and sedimentation controls are specified in Section 02270 “Sedimentation and Erosion Controls”. At the completion of the work, ditches shall be backfilled and the ground surface restored to original condition.
- B. Clearing of vegetation shall be limited to what is necessary for equipment to access the manholes. Roots shall not be removed.

3.3 PROTECTION OF STREAMS AND SURFACE WATERS

- A. Temporary stockpiling of soil materials shall be upgradient of the hay bale barrier to prevent sediments from being transported to adjacent wetland resource areas.
- B. Take all precautions to prevent, or reduce to a minimum, any damage to any stream or surface water from pollution by debris, sediment or other material, or from the manipulation of equipment and/or materials in or near such streams. Water that has been used for washing or processing, that contains oils or sediments that will reduce the quality of the water in the stream, shall not be directly returned to the stream. Divert such waters through a settling basin or filter before being directed into streams or surface waters.
- C. Do not discharge water from dewatering operations directly into any live or intermittent stream, channel, wetlands, surface water or any storm sewer. Water from dewatering operations shall be treated by filtration, settling basins, or other approved method to reduce the amount of sediment contained in the water to allowable levels.
- D. Take all preventative measures to avoid spillage of petroleum products and other pollutants. Maintenance and refueling of vehicles will take place outside of the 100-foot buffer zone to any resource areas. In the event of any spillage, prompt remedial action shall be taken in accordance with a contingency action plan approved by the Rhode Island Department of Environmental Management. A supply of “Speedy Dry”, oil absorbent pads, or an approved equivalent, shall be maintained with the construction equipment at all times which shall be used to contain any accidental release of oil or other petroleum products during the field work. Submit two copies of approved contingency plans to the Engineer.

3.4 PROTECTION OF LAND RESOURCES

- A. Restore land resources within the project boundaries and outside the limits of permanent work to a condition, after completion of construction that will appear to be natural and not detract from the appearance of the project. Confine all construction activities to areas shown on the Drawings.
- B. Do not deface, injure, or destroy trees or shrubs, nor remove or cut them without prior approval. No ropes, cables, or guys shall be fastened to or attached to any existing nearby trees for anchorage unless specifically authorized by the Engineer. Where such special emergency use is permitted, first wrap the trunk with a sufficient thickness of burlap or rags over which softwood cleats shall be tied before any rope, cable, or wire is placed. The Contractor shall in any event be responsible for any damage resulting from such use.
- C. Before beginning operations near them, protect trees that may possibly be defaced, bruised, injured, or otherwise damaged by the construction equipment, dumping or other operations, by placing boards, planks, or poles around them. Monuments and markers shall be protected similarly.
- D. Trees or other landscape features scarred or damaged by the Contractor's equipment or operations shall be restored as nearly as possible to their original condition. The local Tree Warden will decide the method of restoration to be used and whether damaged trees shall be treated and healed or removed and disposed of.
 - 1. All scars made on trees by equipment, construction operations, or by the removal of limbs larger than 1-in in diameter shall be coated as soon as possible with an approved tree wound dressing. All trimming or pruning shall be performed in an approved manner by experienced workmen with saws or pruning shears. Tree trimming with axes will not be permitted.
 - 2. Climbing ropes shall be used where necessary for safety. Trees that are to remain, either within or outside established clearing limits, that are subsequently damaged by the Contractor and are beyond saving in the opinion of the Engineer or local Tree Warden, shall be immediately removed and replaced.
- E. The locations of the Contractor's storage and other construction buildings required temporarily in the performance of the work, shall be cleared portions of the job site or areas to be cleared as shown on the Drawings and approved by the Engineer and shall not be within wetlands or floodplains. The preservation of the landscape shall be an imperative consideration in the selection of all sites and in the construction of buildings.
- F. If the Contractor proposes to construct temporary roads or embankments and excavations for plant and/or work areas, he shall submit the following for approval at least ten days prior to scheduled start of such temporary work.
 - 1. A layout of all temporary roads, excavations, embankments and drainage to be constructed within the work area.
 - 2. Details of temporary road construction.
 - 3. Drawings and cross sections of proposed embankments and their foundations, including a description of proposed materials.
 - 4. A landscaping drawing showing the proposed restoration of the area. Indicate the proposed removal of any trees and shrubs outside the limits of existing clearing area.

Indicate locations of guard posts or barriers required to control vehicular traffic and protect trees and shrubs to be maintained undamaged. The Drawing shall provide for the obliteration of construction scars as such and shall provide for a natural appearing final condition of the area. Modification of the Contractor's approved drawings shall be made only with the written approval of the Engineer. No unauthorized road construction, excavation or embankment construction including disposal areas will be permitted.

- G. Remove all signs of temporary construction facilities such as haul roads, work areas, structures, foundations of temporary structures, stockpiles of excess of waste materials, or any other vestiges of construction as directed by the Engineer. It is anticipated that excavation, filling and plowing of roadways will be required to restore the area to near natural conditions which will permit the growth of vegetation thereon. This work is only anticipated to impact roadways, the disturbed areas will be prepared as described in Section 02270 "Sedimentation and Erosion Control" and Section 02576 "Pavement Repair and Resurfacing."
- H. All debris and excess material will be disposed of outside wetland or floodplain areas in an environmentally sound manner.
- I. All new trees shall be maintained and guaranteed by the Contractor for not less than one full year from the time of provisional acceptance.
- J. At the end of this period, any tree that is missing, dead, not true to name or size as specified, or not in satisfactory growth, as determined by the Engineer, shall be replaced at no cost to the Owner. In case of any question regarding the condition and satisfactory establishment of a rejected plant, the Engineer may allow such a plant to remain through another complete planting season at which time the rejected tree, if found to be dead, in an unhealthy, or badly impaired condition, shall be replaced at once at no cost to the Owner.
- K. All replacements shall be trees of the same kind and size, and the cost shall be borne by the Contractor except where it can be definitely shown that loss resulted from vandalism or the Owner's failure to maintain planting as instructed.
- L. At the end of the maintenance and guarantee period, and after all necessary corrective work has been completed, an inspection will be made by the Engineer who will certify in writing the final acceptance of the trees.

3.5 PROTECTION OF AIR QUALITY

- A. Burning - The use of burning at the project site for the disposal of refuse and debris will not be permitted.
- B. Dust Control - Maintain all excavations, embankment, stockpiles, access roads, plant sites, waste areas, borrow areas and all other work areas within or without the project boundaries free from dust which could cause the standards for air pollution to be exceeded and which would cause a hazard or nuisance to others.
- C. An approved method of stabilization consisting of sprinkling or other similar methods will be permitted to control dust. The use of petroleum products is prohibited. The use of chlorides may be permitted with approval from the Engineer.

- D. Sprinkling, to be approved, must be repeated at such intervals as to keep all parts of the disturbed area at least damp at all times, and the Contractor shall have sufficient competent equipment on the job to accomplish this. Dust control shall be performed as the work proceeds and whenever a dust nuisance or hazard occurs, as determined by the Engineer.

3.6 NOISE CONTROL

- A. Make every effort to minimize noises caused by the construction operations. Equipment shall be equipped with silencers or mufflers designed to operate with the least possible noise in compliance with Federal and State regulations.

3.7 MAINTENANCE OF POLLUTION CONTROL FACILITIES DURING CONSTRUCTION

- A. Maintain all facilities constructed for pollution control as long as the operations creating the particular pollutant are being carried out or until the material concerned has become stabilized to the extent that pollution is no longer being created.

END OF SECTION

SECTION 01170
SPECIAL PROVISIONS

PART 1 GENERAL

1.01 GENERAL OBLIGATIONS OF THE CONTRACTOR

- A. General obligations of the Contractor shall be as set forth in the Contract Documents. Unless special payment is specifically provided in the payment paragraphs of the specifications, all incidental work and expenses in connection with the completion of work under the Contract will be considered a subsidiary obligation of the Contractor, and all such costs shall be included in the appropriate items in the Bid Form in connection with which the costs are incurred.
- B. Obtain and maintain all licenses required to complete the work, including but not limited to plumbing, contractor, municipal contractor licenses.

1.02 SITE INVESTIGATION

- A. Review and become familiar with the conditions existing within the project area, the type of equipment required to perform the work, the character, quality and quantity of the subsurface materials to be encountered insofar as this information is reasonably ascertainable from an inspection of the site(s), as well as from information presented by Contract Maps, Details and Specifications. Failure of the Contractor to become acquainted with the available information will not relieve the Contractor from the responsibility for estimating properly the difficulty or cost of successfully performing the work. The Owner assumes no responsibility for any conclusions or interpretation made by the Contractor on the basis of the information made available by the Owner.

1.03 COORDINATION WITH LOCAL AGENCIES

- A. Coordinate with the local Police Department, public and private schools, Fire Department, Traffic Engineering Department, Public Works Department, the Rhode Island Department of Transportation, the Owner, and other City and local agencies as required, and supply the following information.
 - 1. A list of streets and intersections where work will be performed and the schedule (dates and work hours) for the work.
 - 2. Areas and dates where approved detours will be in effect.
 - 3. Immediate notification of any drain, sewer, gas or water main breaks or damage to any other utilities.
- B. Advise local agencies of changes in the work schedule and locations immediately and provide construction progress updates.
- C. Provide the Owner and Engineer with a list of after-hours telephone numbers by which appropriate Contractor personnel may be contacted in the event of an emergency.

- D. Maintain pavement as specified in Section 02576 and provide the Owner with a telephone number where the Contractor may be reached at any time of day or night. Upon notification by the Owner or the Engineer, promptly make such repairs as necessary to paved surfaces.

1.04 EMPLOYEE IDENTIFICATION AND BACKGROUND CHECKS

- A. The successful bidder is required to submit all names of all employees who will be performing work on behalf of the Owner. The successful bidder, at no cost to Owner, is required to perform a State of Rhode Island BCI check on those employees. The Owner requires a sworn notarized affidavit that the named employees performing the work have successfully passed a State of Rhode Island BCI check. As new employees, and or subcontracted employees are hired, a State of Rhode Island BCI check must be performed for each individual. Submit an updated BCI screening list prior to them performing work for the Owner. The successful bidder is responsible for the professional behavior of their employees and Subcontractor employees while working at the Owner's job site.
- B. In the event of mitigating circumstances or blemishes found on the BCI, the Owner may consider granting an exemption. Exemptions are considered on a case by case basis, once all parties agree to release the BCI results to the Owner. The Owner's executive panel will review all exemption requests and make a determination.
- C. The Owner reserves the right to deny access to private property to any person, as allowed by law. All of Contractor's employees, and subcontractor's staff and all other people associated with the Work that are to enter private property are required to possess and carry a valid and current Driver's License, Identification Card (issued by the Rhode Island Division of Motor Vehicles), or current driver's license from another State in the United States. This identification must include a photograph and signature of the holder.
- D. Anyone entering private property will also be required to carry a Contractor ID badge provided by Providence Water. Badges to be provided by Owner after proof of an acceptable BCI check. Allow 10 days for the badge to be provided.
- E. Order identification badges through the Owner for all new employees or subcontractor's employees that will be working on private property throughout the course of the project after an acceptable BCI check.
- F. Keep a written record of the name, employer and work telephone number of each person issued a photo identification badge. Lost or missing badges shall be reported immediately to the Engineer.
- G. If any Contractor's employee is reassigned to other sites or terminated during the construction, the Contractor shall return the badge issued to that employee to the Owner. The Contractor shall be responsible for collecting and returning the badges from all Contractors' staff, all subcontractor's staff all other personnel when their particular assignment on the site is complete.
- H. It is required that all trucks and equipment shall be marked with company logo. Contractor employees and subcontractors shall wear a uniform shirt or vest with the Contractor's logo displayed at all times while working.

1.05 HOURS OF CONSTRUCTION

- A. Work outside of normal hours as specified in Section 01014 may be done upon Customers' request. Notify Owner and Engineer of such work and Contractor shall make all accommodations to meet such Customer requests. All work performed to accommodate the Customer shall be done at no additional cost to Owner; this includes overtime and weekend work.

1.06 PUBLIC UTILITIES

- A. Comply with all state and local requirements related to excavations in public and private property. Compliance shall include the following:
 - 1. Notify public utility companies in writing at least seventy-two (72) hours (excluding Saturdays, Sundays and legal holidays) but not more than thirty (30) days before excavating in areas where underground utilities (pipes, cables, manholes, etc.) exist.
 - 2. The Contractor shall be responsible for providing the Utility Companies with a schedule of his activities in areas where their utilities exist.
 - 3. Immediately notify utility companies of any damage to their utilities resulting from construction operations and coordinate repair to such utilities with the utility company at no cost to the Owner.
 - 4. Notify Dig Safe at 811 at a minimum of 72 hours before digging, trenching, boring, test pits, backfilling, grading, landscaping, or other earthmoving operations in any public ways, rights of way and easements.
- B. All mark outs of utilities shall be considered by the Contractor as the approximate location for the purpose of damage prevention. The Contractor shall be solely responsible for employing prudent techniques to determine the precise position of the water distribution system underground facility for connection purposes. The cost for this work shall be included in Bid Items 1A, 1B, 2A, or 3A. No additional compensation or time extensions will be made for mis-marked utilities.

1.07 PERMITS

- A. The Contractor shall be required to obtain all necessary permits for proper execution of the project. Contractor shall prepare all forms and furnish all drawings required to obtain the permits. Where necessary Owner will sign application forms as the utility owner. Electronic copies of all approved permit shall be submitted to the Engineer. Applications and permits shall be saved individually and categorized by street address, permit type and permit number. Permit fees will not be reimbursed through an allowance item but will be included as part of the respective replacement bid item. Work shall not commence on any phase of the work requiring a permit until the permit is obtained.
- B. Submit applications for and obtain all required Traffic Engineering, Road Opening (municipal and State), Sidewalk Opening, and Street Closure Permits for excavations and work within streets or sidewalk areas..

- C. Prepare and submit the Plumbing Permit and Providence Water Supply Board's Standard Service Application on behalf of the Customer. Plumbing permit fees are included as part of bid items 2A, 2B, 3A, and 3B and will not be reimbursed under any allowance item.

1.08 DOOR HANGERS

- A. The Contractor shall be responsible for printing and distributing the following door hangers. The door hangers shall be printed 2-sided full color on white 12 pt stock with full bleed print with a cutout and slit at the top for the doorknob or handle. The Engineer will provide the door hanger electronic files for printing and distribution by the Contractor.
 - 1. Scheduling Replacements
 - 2. 72-Hour Notice to Scheduled Replacements and to Other Impacted Residents on the Street
 - 3. 24-Hour Reminder of Scheduled Replacement
 - 4. Notification About Household Flushing
 - 5. Critical Flushing When No Access to Spigot
 - 6. Last Chance for Properties Not Yet Signed Up

1.09 DISRUPTIONS TO THE EXISTING WATER SYSTEM

- A. If during the course of the excavation, the Contractor, for whatever reason, causes existing water mains to fail, restore service in the shortest possible time, working around the clock if necessary. Pay all costs associated with, or resulting from, all water main breaks at no additional cost to the Owner or Customer. Cooperate with the Owner in supplying emergency water.
- B. Planned or scheduled water shutdowns (only if approved by the Engineer or Owner) require the Contractor to notify the Owner in writing at least 72 hours prior to work on the existing water distribution system, including water distribution shutdown requests.
- C. Notify all affected residents and businesses along the project limits of any impending water main or water service work. It is the Contractor's responsibility to provide and distribute written notifications describing the expected water distribution system construction activities, the responsibility of the residents and/or businesses, how long the residents and/or businesses will be without service, and the estimated time of completion of the water distribution system construction activities. The notice should identify the location of the water distribution system construction activities as well as the times of any disruptions to the water system. The water distribution system shall not be taken out of service unless everyone serviced by the water main or water service has been notified at least 72 hours in advance. Notifications shall include 24-hour local or toll-free telephone numbers on the written notification in order to accommodate the residents' or business owners' questions or comments. Notices shall be approved in advance by the Owner and Engineer and shall be written in English and Spanish.
- D. Remind customers of the disturbance within 24 hours of the loss of service. This shall be either the day before the replacement is scheduled or the morning of.

1.10 TOOLS

- A. Any special tools unique to a special piece of equipment or appurtenances (including grease guns or other lubricating devices) which may be necessary for the adjustment, operation, and maintenance of any equipment or appurtenances shall be furnished with the respective equipment.

1.11 PARTS

- A. Parts for certain appurtenances have been specified in the pertinent Sections of the Specifications. Deliver to the Owner all required parts.
- B. Parts shall be packed in original cartons, properly labeled with indelible markings with complete descriptive information including manufacturer, part number, and part name.

1.12 CONNECTIONS TO EXISTING WATER MAINS

- A. Perform all work necessary to locate, excavate and prepare for connections to the existing mains and service connections. The cost for this work and the physical connection of new water service lines to the existing mains shall be included in the replacement bid items for the project and shall not result in any additional cost to the Owner.
- B. The Owner may direct services be transferred to a newer or larger adjacent main located on the same part of the street as the lead service line replacement. Existing service will be capped/plugged at the existing main. The service shall be transferred to the adjacent main, with a new connection of the same size as the service line. The cost for this work and the actual connection to the adjacent mains shall be included in the respective replacement bid item and shall not result in any additional cost to the Owner.

1.13 EXISTING WATER SERVICE LINES

- A. Existing service lines made of galvanized steel are known to be brittle and have several bends. They may not extract in one piece if pipe pulling is used. The difficulty of pulling the existing pipe shall not result in any additional cost to the Owner.

1.14 UTILITY CROSSINGS

- A. It is intended that wherever existing utilities such as water, sewer, electrical or other service lines must be crossed, deflection of the pipe within recommended limits and cover shall be used to clear the obstruction satisfactorily. However, when in the opinion of the Owner or Engineer this procedure is not feasible the Engineer may direct the use of fittings for a utility crossing.

1.15 DAMAGE ON ACCOUNT OF HIGH WATER

- A. The Contractor will hold themselves responsible for all damage done to Contractor's work by heavy rains or floods, and Contractor shall take all reasonable precautions to provide against damages by building such temporary dikes, channels, or shoring to carry off stormwater as the nature of the work may require.

1.16 RELOCATIONS

- A. Contractor is responsible for the relocation of above-ground structures, including but not limited to light poles, signs, sign poles, fences, piping, laterals and french drains that interfere with the positioning of the work. The cost of all such relocations including labor, materials and equipment shall be included in the replacement bid items for the project and shall not result in any additional cost to the Owner. Costs imposed by the a utility to protect their infrastructure will be paid for under the appropriate allowance item.

1.17 OBSTRUCTIONS

- A. The attention of the Contractor is drawn to the fact that during excavation at the Project site, the possibility exists of the Contractor encountering various water, sewer, electrical, or other lines unknown to Engineer. Exercise extreme care before and during excavation to locate and flag these lines to avoid damage to the existing lines. Should damage occur to an existing line, repair the line at no cost to the Owner.
- B. It is the responsibility of the Contractor to ensure that all utility or other poles, the stability of which may be endangered by the close proximity of excavation, are temporarily stayed in position while work proceeds in the vicinity of the pole and that the utility or other companies concerned be given reasonable advanced notice of any such excavation by the Contractor.

1.18 WATER SERVICE LINE REPLACEMENT PROCESS

- A. Refer to the details in Appendix B for additional requirements and notes related to the water service lines.
- B. Locations for Service Line Replacement
 - 1. Contractor is required to visit the streets of the proposed replacements to become familiar with all conditions that may in any manner affect cost, progress or performance of the work, including conditions that exist prior to construction at every location for purposes of restoring conditions to at least equal to what exists prior to construction as part of the final restoration requirements of this project. Contractor's submission of a Bid for this project will constitute an incontrovertible representation that Contractor has visited all of the streets with proposed lead service line replacements, including for purposes of reviewing existing conditions to establish bid prices for this work for all potential final restoration as part of this work. Submission of a Bid for this project will also constitute an incontrovertible representation that Contractor is satisfied with all of the site conditions that may affect the cost, progress or performance of the work of this project.
 - 2. A list of addresses for replacement of existing lead service lines as part of this project are provided in Appendix A of this Project Manual and will be available in leadCAST. A list of customers at these addresses that have signed the Right-of-Entry (ROE) and Release Form for Lead Service Line Replacement will be continuously updated and shared by the Engineer to the Contractor via leadCAST. The Contractor shall make four (4) documented attempts to obtain a signed ROE from homeowners and log attempts in leadCAST. The four (4) attempts shall be on different dates and times and using different media (i.e. doorhangers, phone calls, door-to-door, etc.) and documented in the data management system. A minimum of three (3) of the attempts must be door-to-door. A maximum of one (1) of the attempts can be a phone call or email. The Contractor shall leave notification each time with a phone number for the Customer to contact them. If after four attempts, the

ROE is not completed, the Contractor shall inform the Owner and Engineer in writing of the address, Customer name and the documented four (4) failed attempts including date, time and media. The Engineer may attempt to contact the Customer within 72 hours of the Contractor notifying the Engineer. The cost for this effort shall be included in the replacement bid items and no additional payment will be provided for the outreach effort. If the homeowner refuses the replacement prior to the third attempt, the Contractor shall document the refusal (i.e. address, customer name, date and time of refusal, reason for refusal, and person obtaining the refusal) and does not need to complete the remaining attempts. Provide any signed ROEs to the Inspector to confirm eligibility and add into the master list. For services that do not have a signed ROE reviewed and confirmed by the Engineer, no work shall take place. Owner reserves the right to revise the locations intended for lead service line replacements, including:

- a. Adding or replacing proposed locations of replacements for any reason.
- b. If replacement locations are added to the contract, these locations will be within the Work Area as defined in Appendix A.
- c. Replacements and Test Pits at addresses added during construction shall be paid in accordance with the bid items in the Bid Form.
- d. Owner will make every effort to ensure the proposed number of replacement locations will be provided to the Contractor. However, if the final replacement number is less than the bid quantity, Contractor shall have no claim to modify the price of the unit price item.

C. Right-Of-Entry and Replacement Agreement

1. Before scheduling or commencing any work on private property, Contractor will obtain the consent of each Customer with a signed Right of Entry (ROE) and Release Form for Lead Service Line Replacement (a sample is provided at the end of this section). No work shall commence on private property until Contractor has received a signed ROE and Release Form for Lead Service Line Replacement authorizing permission to complete work on private property and the ROE is submitted to and approved by the Owner.
2. Contractor shall print the form for signature by the homeowner. In lieu of providing and collecting hard copies of the ROE, the Contractor may obtain signatures electronically through the leadCAST platform.
3. If an executed hard copy of the ROE is obtained by the Contractor, the Contractor shall upload the signed ROE to the leadCAST platform.

D. Coordination with Owner

1. Coordinate all work activities with the Owner and Engineer.

E. Coordination with other contractors

1. Coordinate all work activities with any other Contractors performing work in adjacent areas.

F. Coordination with Customers

1. Engineer or Owner will confirm Homeowner signatures on the ROE and Release Form for Lead Service Line Replacement obtained by the Contractor prior to Contractor

- commencing construction activities. Contractor shall coordinate with Customers on the list in Appendix A by scheduling an inspection to confirm the presence or absence of a lead water service line.
2. If, at a property where a full replacement or private side replacement was expected to take place, copper is observed at the wall/floor penetration inside the home, Contractor shall perform a test pit at the curb stop to confirm the private side material. If both the private side is also copper at the curb, no replacement shall take place and Contractor will be paid for a public-side only replacement or a test pit as described in Section 01025.
 3. Prior to commencing work at locations listed as public side only replacements, confirm the material on the private side with a test pit. If the material is found to not be lead on the private side, proceed with the public side replacement paid for under Bid Item 1A and no additional payment will be made for the test pit. If the private sidematerial is found to be lead, both sides must be replaced. Obtain an ROE prior to commencing the replacement work. If an ROE is not obtained, Contractor is not to replace either side and will be paid for a test pit under Bid Item 1C if a test pit was conducted.
 4. Contractor shall make and document four (4) attempts to schedule the work. The four attempts shall be on different days and times. The Contractor shall leave notification each time with a phone number for the customer to contact them by phone and document each attempt in the data management system. . If after four attempts, the customer does not respond, the Contractor shall inform the Owner and Engineer in writing of the address, and Customer name, as well as, information on the four (4) failed attempts including date, time and summary of attempts made. The Owner may attempt to contact Customer within 72 hours of the Contractor notifying the Owner. If no permission is granted by the Customer, the Contractor will not be compensated for any work at this address.
 5. The Contractor is responsible for scheduling and coordinating all work at each individual location with the Customers, including approximate dates when work will begin and end. For each location, Contractor shall provide to the Customers a general description of work to be performed and contact information of the Contractor, Engineer, and Owner. The Contractor shall schedule all replacement types, including public side only replacements, when homeowner is home unless the private side material is confirmed non-lead ahead of the replacement.
 6. Coordinate all work activities with Customers whose water service may be temporarily interrupted to facilitate work for this project. No water services shall be disconnected without alerting the customer and for a duration more than 8-hours.
 7. Schedule construction activities at the convenience of the Customer. If the Customer cancels the work or is unavailable at the time of the scheduled appointment, the Contractor shall attempt to reschedule the work with the customer within 72 hours at the mutual convenience of the Customer and Contractor. If the customer refuses to reschedule within 72 hours, the Contractor shall be compensated via the unit price bid item for Access Not Provided. Submit documentation of the scheduled appointment and the customer's confirmation that the appointment was accepted and then cancelled or proof that the customer did not show up for the appointment. This shall be documented in the leadCAST platform by the Contractor.
 8. Customer shall provide reasonable access and a working area for the Contractor at the service line and water meter location inside their home. If such access is not provided, Contractor shall request Customer provide such access within 72 hours. If no access is provided during that time, immediately inform Owner and Engineer in writing of the address and Customer name. If no access is provided by the Customer, then they shall be removed from the contract list, and the Contractor shall be compensated via the unit price bid item for Access Not Provided. No other work will be compensated at this address.

9. Any Contractor personnel that will enter private property for any work on this project are required to have background checks and badges/identification. Only personnel which have completed background checks and issued badges/identification by the Owner shall enter private property. No Contractor personnel will be allowed to attempt entry into private property or enter private property without wearing proper identification.
10. The Contractor, subcontractors and all members of the construction crew shall continuously use all courtesies when working with the residents and their property. Such practices include, but are not limited to, using foot covers when inside the home, using electric saws and performing dust control to minimize any air contamination. Contractor shall minimize property disturbance to the minimum necessary disturbance in order to complete the replacement work. Contractor shall not request to use the bathrooms of the residents.

G. Photographic Documentation

1. Photographic documentation shall be in accordance with Section 01322 of these Specifications.
2. The Contractor is not allowed to start any work at any location until the Contractor has submitted pre-construction photographic documentation at each location. This requirement intends to document conditions existing prior to construction to establish documentation and visual evidence to confirm all needed final restoration that is at least equal to conditions existing prior to construction. No payment will be made to Contractor for work performed at a location unless photographic documentation is submitted in leadCAST for that location.
3. Provide photographic documentation of all completed work at all locations. This requirement intends to provide final visual evidence and a final record of final restoration. No payment will be made to Contractor for work performed at a location unless photographic documentation is submitted in leadCAST for that location.

H. Test Pits

1. A test pit is defined as a planned service line replacement that is found not to be lead on either side. A test pit shall be assumed to be at least 6-feet in length, or consist of two separate holes, to verify the materials at least 3-feet on both sides from the curb stop are not lead. Photograph the service line materials in accordance with Section 01322, and record the Private and Public-side materials, to verify both sides of the curb stop.
2. If a planned replacement results in a test pit, backfill in accordance with Paragraph 3.05 in Section 02221 and the details in Appendix B. Payment will be made under Bid Item 1C. If a property is not on the list in Appendix A and has not been added by the Owner or Engineer, any test pit performed will be for the convenience of the Contractor and will not be paid under Bid Item 1C.
3. Water service must be turned off before any excavation near the lead service line, including test pits. Notify the Customer prior to turning off water service in accordance with Part E above.
4. Engineer or Owner may request test pits for identifying materials at additional properties. If a test pit does not result in a replacement at that address, backfill and restore in accordance with Paragraphs 3.05 and 3.06 in Section 02221 and the details in Appendix B only once the material information is obtained and recorded. Payment would be made under Bid Item 1C for requested test pits by the Engineer or Owner. Test pits requested by Owner or Engineer shall be performed to minimize disturbance to lead service lines while positively identifying the service line material on both sides of the curb stop.

5. Test pits are to be behind the curb only. Test pits in roadways shall only be performed at the direction of the Owner or Engineer, and Controlled Low-Strength Material (CLSM) shall be used to ensure required compaction and strength are achieved. The backfilled surface shall be maintained in a satisfactory condition for travel until resurfaced as specified.
6. Owner will provide Customer with flushing instruction flyer after any test pit or excavation is conducted within 5-feet of a lead service line.

I. Additional Replacements

1. Contractor may, at Owner's direction, commence replacement at a property that is not on the list in Appendix A under all of the following conditions:
 - a. An LSL not listed in Appendix A is discovered to be in the same trench as a planned replacement once and ROE is signed and reviewed by the Owner or Engineer if the private-side is impacted.
 - b. A signed ROE and Release Form for Lead Service Line Replacement for the property not listed in Appendix A has been received by the Owner and added to the list of replacements.
 - c. The Owner has approved a replacement at this location.
 - d. Any additional homes will not replace the addresses already on the list in Appendix A.

J. Water Service Line Replacements

1. All work, including final interior connections performed by a licensed plumber in accordance with the RI Plumbing Code for lead service line replacements at each location must be completed in a maximum time not to exceed 8 hours. Temporary shutdowns of service lines to facilitate replacement of lead service lines shall not exceed 8 hours and in no case shall any customer or location be without potable water service longer than 8 hours.
2. Unless otherwise approved by the Engineer, all work shall be performed with water mains live and in service as specified in Section 02663.
3. Buildings in this area should assumed to be grounded to the water service line. See Section 02663 for the requirements under this contract related to grounding.
4. Unless otherwise approved by the Engineer, all planned service line replacements shall begin with an excavation behind the curb to confirm existing service line materials on both the public and private side of the curb stop. Excavation in roadways shall only be performed once the service line materials are confirmed to be lead and require replacement.
5. New water service lines to replace existing lead services shall be as specified in Section 02663. The minimum size of all new service lines is 1-inch.
6. Typical water service connection details are included in Appendix B to the Specifications. These details represent typical conditions for water service line replacement. Each location will vary.
7. Final connection of new service lines to the existing water meter in buildings will be made by a licensed plumber in accordance with the RI Plumbing Code included in this Contract. Coordinate all work with Engineer and Owner.
8. Contractor shall be prepared and responsible for draining and handling water from building plumbing after cutting into the existing service lines to facilitate the installation of new work. All water drained from building plumbing shall be drained outside of the building not to flood the existing building basement.
9. Refer to Appendix B for the standard details for this project and additional requirements for water service line installations.

K. Existing Sewer Service Connections

1. Water and sewer services may be located in close proximity and/or the same trench at many locations. The Contractor is cautioned as to the proximity of existing sewer services to the existing water service line.
2. Any existing sewer service connection that is broken or damaged by the Contractor during construction shall be repaired with all pipe, fittings, and couplings at no additional cost to the Owner. No separate payment will be paid for the repair of existing sewer service connections damaged by the Contractor.

L. Illegal Water Service Connections

1. If during work an illegal water service tap is discovered upstream of a meter, Contractor shall document with photographs and immediately contact Owner and Engineer.
2. After inspection by Owner or Engineer, Contractor shall remove the illegal service line up to property line or to the extent in which it is exposed. If removal is not possible, the pipe shall be crimped in two locations a minimum of 1-foot apart. If a replacement of a lead service line occurs, payment shall be under Item 1A, 1B, 2A, 2B, 3A, or 3B. in the bid form. If no replacement of a lead service line occurs, payment shall be under the Miscellaneous Work at Direction of Owner Allowance Item.
3. If during work an address is discovered to not have a water meter present, Contractor shall document with photographs and immediately contact Owner and Engineer.

M. Final Restoration

1. Before starting construction at any location, Contractor shall review features that will be impacted by construction that shall be restored to a condition at least equal to that which existed prior to construction.
2. The Contractor is required to restore all areas to a condition at least equal to that which existed prior to construction, other than the items listed in the Right of Entry (ROE) and Release Form for Lead Service Line Replacement, within 90 days of the test pit or replacement, with the exception of final sidewalk restoration which may occur after 90 days as specified. Final road restoration shall be performed on streets shown in Appendix C. The Engineer will inspect all work and will inspect pre- and post-construction photographic and video documentation to confirm that all final restoration is acceptable, including restoration on private property as specified in Sections, 02576 Pavement Repair and Resurfacing, and 02930 Loaming and Seeding. Damage to private property shall be the responsibility of the Contractor.

1.19 EXCAVATED SOIL

- A. The project excavation areas are located within the public right of way and private property. All excess soils for disposal shall be excavated, stockpiled, hauled and disposed of in accordance with all local, state and federal regulations at no additional cost to the Owner.
- B. Native soil may be reused on the property it was excavated from if it meets the requirements for Common Fill in accordance with Section 02230.

1.20 PALLETIZE COBBLESTONES

- A. Cobblestones dug out as part of this project shall be palletized and shipped to the City of Providence or Cranston yard depending on the jurisdiction where the cobblestone is removed from.

END OF SECTION

PROVIDENCE WATER SUPPLY BOARD (PWSB)

RIGHT OF ENTRY AND RELEASE FORM FOR LEAD SERVICE LINE REPLACEMENT.

PLEASE RETURN BY

PERSONAL CONTACT INFORMATION (REQUIRED)

Owner Name(s):

Account Number **(From PWSB Water Bill)**:

Providence Water ("PWSB") requests that you, as an owner of your Property ("**you**"), sign, complete, and return this document ("**Right of Entry**") to grant PWSB's Contractor and Representatives a right of entry onto your property, at the address ("**your Property**"), so PWSB may provide your Property with a lead service line replacement (the "Work"). *If you are a tenant*, please provide a copy of this Right of Entry to your landlord and have the landlord sign. *If your property is rented*, please notify your tenant of the scheduled work.

REASON FOR PWSB'S REQUEST FOR A RIGHT OF ENTRY:

LEAD SERVICE LINE REPLACEMENT: PWSB's records indicate that the pipe from PWSB's water main to your home may be made of lead. PWSB's contractor will be replacing the service. PWSB's Contractor, and other Representatives will need access to your Property to perform work associated with the lead service removal and replacement. Before beginning, PWSB's Contractor will notify you when they will be on your Property to perform the work. It is your responsibility to provide reasonable access and a safe and appropriate working area for the Contractor at the service line and water meter location as requested by the Contractor. The Contractor and PWSB Representatives may continue to enter onto your Property until construction is completed and you and PWSB accepts the work.

RIGHT-OF-ENTRY:

By signing and returning this Right of Entry, you grant PWSB, its Representatives and Contractor the right to enter your Property between the hours of 7:00 a.m. and 6:00 p.m. The right to enter your property is for the purpose of **replacement of your lead service line.**

PWSB's Contractor will identify themselves prior to entering the property.

This Work involves shutting off your water service for an estimated eight (8) hours, removal of your existing lead water service, installation of a new copper service from the street to your home and through your basement to the existing water meter, connection to PWSB water main and flushing the new service. Work also involves interior work in the area of the water meter to install the new copper service from the exterior to the interior of the building, including plumbing work (e.g., new valves, backflow preventer, expansion tank, pressure reducing valve, etc.) in the area of the water meter to meet the current Plumbing Code.

All construction excavations will be backfilled, topped with topsoil, and seeded. Any removed asphalt or concrete will be replaced in-kind. The penetration through the building wall or floor will be sealed. No other restoration of existing internal surfaces, finishes or other features will be performed.

Any other items located in the way of the construction and disturbed during construction on private property outside the building (including but not limited to walls, fences, shrubs and other landscaping, brick sidewalks or driveways, and lawns requiring specific seed or sod), will not be restored. If disturbed by the Contractor, stones, fences, shrubs, plants, bricks, sod, etc., will be left on the property for re-use by the Owner, and the costs of re-installation or restoration shall be borne by the Owner. Neither PWSB nor the Contractor is responsible for damage to trees, shrubs, and living plant material disturbed as a result of construction operations to replace the private service line. The Owner will be required to dig up plant materials that they wish to save prior to the start of construction and provide the necessary protection for the plants during construction. The Owner will be responsible for the replanting of the plant material.

In consideration of the foregoing, you affirm that you are the lawful, recorded owner at your Property and hereby grant PWSB Right of Entry allowing PWSB and its contractors, agents, and employees to enter your Property, take photographs and videos of the interior and exterior of your property in the area of the water service line before and after installation, bring workers, material, equipment, and supplies onto your Property and to utilize your Property for the purpose of performing your lead service line replacement. The contractor's work is warranted for one (1) year after the replacement. If you have any issues or concerns with the work during this one-year period, please contact the Contractor that performed the work first (using the contact information provided by the Contractor) and allow 48 hours for the Contractor to respond. If you are not satisfied with their response, please contact the Lead Service Line Replacement Hotline at (401-575-0776).

IN CONSIDERATION OF AND AS A CONDITION TO THE PERFORMANCE OF THE LEAD SERVICE LINE REPLACEMENT, YOU, THE UNDERSIGNED, HEREBY RELEASE AND FOREVER DISCHARGE PWSB, ITS EMPLOYEES, AND LEGAL REPRESENTATIVE (COLLECTIVELY THE "PWSB") FROM ALL LIABILITY FOR INJURY, DEATH, DAMAGE, OR LOSS TO PERSONS, REAL PROPERTY, OR PERSONAL PROPERTY IN CONNECTION WITH THE PERFORMANCE OF THE LEAD SERVICE LINE REPLACEMENT. YOU UNDERSTAND THAT PWSB'S CONTRACTOR ACTUALLY PERFORMING THE WORK WILL BE RESPONSIBLE FOR ANY CLAIM IN CONNECTION TO THIS RIGHT OF ENTRY FOR DAMAGE TO YOUR PROPERTY OR ASSETS ON YOUR PROPERTY.

PW AND ITS CONTRACTOR ARE NOT RESPONSIBLE FOR ANY DAMAGE CAUSED BY FAULTY EXISTING ELECTRICAL (SUCH AS INCORRECT GROUNDING) OR PLUMBING SYSTEMS WITHIN YOUR HOME OR ON YOUR PROPERTY. IF PW OR ITS CONTRACTOR DETECT ANY IMPROPER ELECTRICAL OR GROUNDING, THE PROPERTY OWNER WILL BE NOTIFIED TO FIRST CONTACT AN ELECTRICIAN TO CORRECT THE ELECTRICAL ISSUES BEFORE THE LEAD SERVICE LINE REPLACEMENT WORK CAN PROCEED.

YES, I, the undersigned, **choose to replace** the portion of the lead service line I own:

Name (Property Owner/Authorized Tenant): _____

Account Number (From PWSB Water Bill): _____

Property Address (Street Number & Street Name): _____

Signature Date Mailing Address (Street Number & Street Name)

Printed name City State Zip

Phone number Email address

ONCE COMPLETED, RETURN BY EMAIL OR MAIL TO CONTRACTOR:

Scan and e-mail:
PWleadfree@cdmsmith.com

Mail:
CDM Smith
3 Davol Square
Building A Suite, A-425
Providence RI 02903

REQUESTS & CLAIMS:

A. YOUR PRESENCE DURING WORK: Someone at least 18 years old must be present during the work to provide access to the Contractor in the area where your water service line enters your home up to your meter.

B. CLAIM PROCEDURES: In order to make a claim against the PWSB's Contractor for damage to your Property in connection to this Right of Entry, please call (401) 575-0776 and have a copy of this Right-of-Entry form available.

NO, I CHOOSE NOT TO REPLACE MY LEAD SERVICE LINE

I, the undersigned, **choose not to replace** the portion of lead service line which I own.

Printed Name

Date

Signature

Telephone Number

Your feedback is important to us. Please check the reason for choosing not to participate in Providence Water's FREE Lead Service Line Replacement Program:

- I am not concerned about lead in drinking water.
- I want to be able to hire my own contractor.
- Other – please explain:

JUNTA DEL SUMINISTRO DE AGUA DE PROVIDENCIA (PWSB)

PERMISO DE ENTRADA Y FORMULARIO DE AUTORIZACIÓN PARA EL REEMPLAZAMIENTO DE TUBERÍAS DE SERVICIO DE PLOMO.

FAVOR DE ENVIAR ANTES DE

INFORMACIÓN PERSONAL DE CONTACTO (OBLIGATORIA)

Nombre del/de la propietario/a:

Número de cuenta **(De la Factura de agua de PWSB):**

Providence Water ("PWSB") requiere que usted, como dueño de su propiedad ("usted"), firme, complete y envíe este documento ("**Permiso de Entrada**") para conceder al contratista y a los representantes de PWSB el permiso de entrada a su propiedad, en la dirección ("**su propiedad**"), para que PWSB pueda realizar en su propiedad el reemplazo de la tubería de servicio de plomo (el "Trabajo"). Si usted es un inquilino, por favor haga posible una copia de este permiso de entrada a su propietario y haga que el propietario firme este permiso de entrada. Si su propiedad *está alquilada*, favor de notificar a su inquilino del trabajo programado.

MOTIVO DE LA SOLICITUD DEL PERMISO DE ENTRADA DE PWSB:

REEMPLAZO DE LA TUBERÍA DE SERVICIO DE PLOMO: Los registros de PWSB indican que las tuberías principales de agua que les proveen servicio a su hogar pueden ser hechas de plomo. El contratista de PWSB reemplazará la tubería. El contratista de PWSB, y otros representantes, necesitarán acceso a su propiedad para realizar el trabajo asociado con la eliminación y el reemplazo de la tubería de servicio de plomo. Antes de comenzar, el contratista de PWSB le notificará cuándo estará en su propiedad para realizar el trabajo. Es su responsabilidad de proveer acceso razonable y un espacio de trabajo segura y adecuada para el Contratista realizar el reemplazamiento de tubería de servicio y la ubicación del contador de agua según los requisitos del Contratista. El Contratista y los Representantes de PWSB tendrán acceso continuamente en su Propiedad hasta que el reemplazamiento esté terminado y usted y PWSB acepten el trabajo.

PERMISO DE ENTRADA:

Al firmar y devolver este Permiso de Entrada, usted otorga a PWSB, sus Representantes y el Contratista, el permiso de entrar a su Propiedad entre las horas de 7:00 a.m. a 6:00 p.m. El permiso de entrar a su propiedad es con el propósito de **reemplazar su tubería de servicio de plomo gratuitamente.**

Los contratistas de PWSB se identificarán antes de entrar en su propiedad.

Este trabajo implica el corte de su servicio de agua durante aproximadamente ocho (8) horas, la eliminación de su tubería de servicio de agua de plomo existente, la instalación de una tubería de servicio de cobre nueva desde la calle hasta su casa y a través de su sótano hasta el contador de agua existente, la conexión a la tubería principal de agua de PWSB y el llenado de la nueva tubería. El reemplazamiento también incluye el trabajo interior en el área del contador de agua para instalar la nueva tubería de servicio de cobre desde el exterior hasta el interior del edificio, incluyendo el trabajo de plomería (por ejemplo, nuevas válvulas, válvula contra reflujo, tanque de expansión, válvula de reducción de presión, etc.) en el área del contador de agua para cumplir con el Código de Plomería actual.

Todas las excavaciones de la construcción se rellenarán, se cubrirán con mantillo y se sembrarán. El asfalto y el hormigón retirados se sustituirán en especie. Se sellará la penetración de la pared o el suelo del edificio. No se llevará a cabo ninguna otra restauración de las superficies internas existentes, acabados u otras características. Cualquier otro elemento situado en el camino de la construcción, y modificado durante la construcción en la

propiedad privada fuera del edificio (incluyendo, pero no limitado a las paredes, vallas, arbustos y otros jardines, aceras de ladrillo o calzadas, y el césped que requiere semillas o césped específico), no será restaurado. Si son modificados por el Contratista, las piedras, las vallas, arbustos, plantas, ladrillos, césped, etc., se dejarán en la propiedad para su reutilización por el Propietario, y los costos de reinstalación o restauración correrán a cargo del Propietario. Ni PWSB ni el Contratista son responsables de los daños causados a los árboles, arbustos y material vegetal vivo perturbado como resultado de las operaciones de construcción para reemplazar la tubería de servicio privada. El Propietario deberá desenterrar los materiales vegetales que desee salvar antes del inicio del reemplazamiento, y proveer la protección necesaria para las plantas durante el proceso del reemplazamiento. El propietario será responsable de volver a plantar el material vegetal.

Teniendo en cuenta lo anterior, usted afirma que es el propietario(a) legal y registrado en su Propiedad y por la presente concede a PWSB el Permiso de Entrada permitiendo a PWSB y a sus contratistas, agentes y empleado(a)s entrar en su Propiedad, tomar fotografías y videos del interior y exterior de su propiedad en el área de la tubería de servicio de agua antes y después de la instalación, llevar trabajadores, material, equipo y suministros a su Propiedad y utilizar su Propiedad con el propósito de realizar el reemplazo de su tubería de servicio de plomo. El trabajo del contratista está garantizado por un (1) año después del reemplazo. Si tiene algún problema e inquietud con el trabajo durante este período de un (1) año, comuníquese primero con el contratista que realizó el trabajo (utilizando la información de contacto probada por el contratista) y espere 48 horas para que el contratista le responda. Si no está satisfecho(a) con su respuesta, comuníquese con Línea Directa de Reemplazo de Líneas de Servicio de Plomo (401-575-0776).

EN CONSIDERACION Y COMO CONDICION PARA LA REALIZACION DEL REEMPLAZO DE LA TUBERÍA DE SERVICIO DE PLOMO, USTED, EL FIRMANTE, POR LA PRESENTE LIBERA Y EXIME PARA SIEMPRE A PWSB, SUS EMPLEADO(A)S Y REPRESENTANTE LEGAL (COLECTIVAMENTE EL "PWSB") DE TODA RESPONSABILIDAD POR LESIONES, MUERTE, DAÑOS O PÉRDIDAS A PERSONAS, BIENES RAÍCES O BIENES PERSONALES EN RELACION CON LA REALIZACIÓN DEL REEMPLAZO DE LA TUBERÍA DE SERVICIO DE PLOMO. USTED ENTIENDE QUE EL CONTRATISTA DE PWSB QUE REALICE EL TRABAJO SERÁ RESPONSABLE DE CUALQUIER RECLAMO EN RELACIÓN CON ESTE PERMISO DE ENTRADA POR DAÑOS A SU PROPIEDAD O A LOS BIENES DE SU PROPIEDAD.

PW Y SU CONTRATISTA NO SON RESPONSABLES DE NINGÚN DAÑO CAUSADO POR SISTEMAS ELÉCTRICOS EXISTENTES DEFECTUOSOS (COMO UNA CONEXIÓN A TIERRA INCORRECTA) O SISTEMAS DE PLOMERÍA DENTRO DE SU CASA O EN SU PROPIEDAD. SI PW O SU CONTRATISTA DETECTAN CUALQUIER CONEXIÓN A TIERRA O ELÉCTRICA INADECUADA, SE NOTIFICARÁ AL PROPIETARIO DE LA PROPIEDAD PARA QUE PRIMERO SE CONTACTE CON UN ELECTRICISTA PROFESIONAL PARA CORREGIR LOS PROBLEMAS ELÉCTRICOS ANTES DE QUE PUEDAN CONTINUAR LOS TRABAJOS DE REEMPLAZAMIENTO DE LA TUBERIA DE SERVICIO DE PLOMO.

Sí, yo, el firmante, elijo reemplazar la parte de la línea de plomo que poseo:

Nombre (Propietario/a/Arrendatario autorizado/a): _____

Número de cuenta (De la Factura de agua de PWSB): _____

Dirección de la propiedad (número y nombre de calle): _____

Firma:

Fecha:

Dirección postal (número y nombre de calle):

Aclaración:

Ciudad:

Código postal del estado:

Número telefónico:

Correo electrónico:

UNA VEZ COMPLETADO, POR FAVOR ENVÍELO POR CORREO ELECTRÓNICO O POR CORREO AL CONTRATISTA:

Por favor escanee y envíe el documento por vía de correo electrónico a: PWleadfree@cdmsmith.com

Dirección Postal: CDM Smith
3 Davol Square
Building A Suite, A-425
Providence RI, 02903

PETICIONES Y RECLAMOS:

- A. SU PRESENCIA DURANTE EL TRABAJO:** Alguien mayor de 18 años debe estar presente durante el trabajo para dar acceso al Contratista en el área donde su tubería de servicio de agua entra en su casa hasta su medidor.
- B. PROCEDIMIENTOS PARA HACER RECLAMOS:** Para presentar un reclamo contra el Contratista de la PWSB por daños a su Propiedad en relación con este Permiso de Entrada, favor de llamar al (401) 575-0776 y tenga en mano una copia de este formulario de Permiso de Entrada.

NO, ELIJO NO REEMPLAZAR MI TUBERÍA DE SERVICIO DE PLOMO

Yo, el firmante, **decido no reemplazar** la parte de la tubería de servicio de plomo de la que soy responsable.

Aclaración

Fecha

Firma

Número telefónico

Su opinión es importante para nosotros. Favor de marcar la razón por la que eligió no participar en el programa de reemplazamiento de tuberías de servicio de plomo **GRATUITAMENTE** de Providence Water:

- No me preocupa el plomo en el agua potable.
- Quiero poder contratar a mi propio contratista.
- Otros - por favor, explique: _____

SECTION 01180 PIPE PENETRATIONS

PART 1 GENERAL

1.01 SCOPE OF WORK

- A. Furnish all labor, materials, equipment, and incidentals required and install pipe penetration assemblies at all floor and wall penetrations. This Section covers materials for the various pipe penetration configurations. Penetration details are provided in Appendix B. Where possible, existing pipe penetration are to be reused. Where penetrations are required the most conservative penetration detail shown on the detail sheets shall be utilized as appropriate for the piping type, the wall or floor construction and the rating of the wall or floor penetrated.
- B. Fill any voids left from removing or installing the water service lines to the satisfaction of the Engineer, Owner and any agency having jurisdiction over the work with approved sealant.
- C. In instances where meter is relocated, fill vacated meter pits with concrete to the satisfaction of the Engineer, Owner and any agency having jurisdiction over the work.

1.02 RELATED WORK

- A. Cutting, coring and patching are included in Section 01045.
- B. Interior service piping and appurtenances are included in Section 15410.

1.03 SUBMITTALS

- A. Submit manufacturers' literature, installation instructions, and where applicable, certified test results of the various components on all items including sleeve, seal, and grout materials to be furnished in accordance with Section 01300.
- B. Submit proposed sealing methods for pipe penetrations.

1.04 WARRANTY

- A. Warrant the work against defects for one (1) year from the date of Substantial Completion.

PART 2 PRODUCTS

2.01 PIPE SLEEVE

- A. Pipe sleeve shall be PVC, galvanized steel or as required by the local plumbing code official.
- B. Wall opening for pipe sleeve shall be cored when a new penetration is used. Annular spaces shall be repaired and sealed with watertight seal between pipe sleeve and existing concrete.
- C. Pipe sleeves are required for penetrations through the wall or floor whether new or existing.

2.02 SEALING MATERIALS

- A. Install mechanical seal between the new copper pipe and the pipe sleeve when coring a new hole. Mechanical seals shall consist of rubber links shaped to continuously fill the annular space between the pipe and the sleeve. Link pressure plates shall be molded of glass reinforced nylon. Hardware shall be mild steel with a 60,000 psi minimum tensile strength and 2-part Zinc Dichromate coating per ASTM B-633 and Organic Coating, tested in accordance with ASTM B-117 to pass a 1,470-hour salt spray test. Links shall be colored throughout elastomer for positive material identification. Each link shall have permanent identification of the size and manufacturer's name molded into the pressure plate and sealing element. The completed sealing system shall be duty pressure rated for 20 psig differential pressure. Link material shall be EPDM "M" for all services except fire-rated assemblies; fire rated seals shall use silicone link material. Modular mechanical seals shall be Link-Seal® as manufactured by Garlock Pipeline Technologies (GPT), an Enpro Industries Company (formerly Thunderline/Pipeline Seal & Insulator [PSI]), or pre-approved equal.
- B. Wrap copper pipe in insulation tape. Insulation tape shall be Harvey's Black Pipe Wrap or equal.
- C. Install sealant in remaining voids between the new copper pipe and the pipe sleeve. Sealant shall be a two-part vulcanizing (RTV) silicone foam by The Dow Chemical Company, Product No. 3-6548 R.T.V. Silicone Foam; 3M brand fire barrier products caulk C.P. 25 and 3M brand moldable putty MP+, or Flame-Safe firestop systems FS-900 by RectorSeal. Sealant bead configuration, depth, and width shall be in accordance with manufacturer's recommendations.
- D. Install swell strip between sleeve and new concrete prior to pouring concrete to fill the meter pit to grade of existing floor. Install second swell strip between new and existing concrete. Swell strip shall be Sika Hydrotite CJ or equal.

2.03 SLEEVE GROUT MATERIALS

- A. Epoxy bonding compound shall be Sikadur Hi-Mod epoxy by Sika Corp.; Euco 452 Epoxy System by Euclid Chemical Corp.; or pre-approved equal.
- B. Non-shrink grout shall be Masterflow 713 by Master Builders Co.; Euco NS by Euclid Chemical Co.; Five Star Grout by Five Star Products. or equal.
- C. Class II Non-Shrink Grout:
 - 1. Class II Non-Shrink grout shall be high precision, fluid, extended working time grout. The minimum 28-day compressive strength shall be 7500 psi when mixed at a fluid consistency.
 - 2. Grout shall have a maximum early age height change of 4.0 percent expansion, and shall have no shrinkage (0.0 percent) in accordance with ASTM C827.
 - 3. Grout shall have no shrinkage (0.0 percent) and a maximum of 0.3 percent expansion in the hardened state when tested in accordance with ASTM C1090.
 - 4. Class II grout shall have an extended working time of 30 minutes minimum when mixed to a fluid consistency as defined in ASTM C827 at temperature extremes of 45 to 90 degrees F in accordance with ASTM C1107.

5. Class II Non-Shrink grouts shall meet the requirements of ASTM C1107; Grade B or C when tested using the amount of water needed to achieve fluid consistency per ASTM C939.
 6. The grout when tested shall not bleed or segregate at the maximum allowed water.
 7. Provide certification that its non-shrink property is not based on gas production or gypsum expansion.
- D. Stone Patching Compound: Factory-mixed cementitious product that is custom manufactured for patching stone.
1. Products: Provide one of the following:
 - a. Cathedral Stone Products, Inc.; Jahn Restoration Mortars.
 - b. Conproco Corporation;
 - c. Edison Coatings, Inc.; Custom System 45.
 - d. Or pre-approved equal.
 2. Use formulation that is vapor and water permeable (equal to or more than the stone), exhibits low shrinkage, has a lower modulus of elasticity than the stone units being repaired, and develops the high bond strength to all types of stone.
 3. Use formulation having working qualities and retardation control to permit forming and sculpturing where necessary.
 4. Formulate patching compound in colors, textures, and grain to match stone being patched. Provide colors to enable matching each piece of stone, to the satisfaction of the Engineer.

PART 3 EXECUTION

3.01 PREPARATION OF SURFACE:

- A. All surfaces that will be in contact with seal shall be free of dirt, loose rust, oil, wax, grease, curing compounds, laitance, loose concrete or other deleterious and all other preparations in accordance with manufacturer's recommendations.

3.02 PROCEDURES

- A. Waterproof seal product shall be placed in such a manner, for the consistency necessary for each application, to assure that the space to be sealed is completely filled.

3.03 CURING

- A. Seals shall be cured per manufacturer's recommendations.

END OF SECTION

SECTION 01300
SUBMITTALS

PART 1 GENERAL

1.01 SCOPE OF WORK

- A. This Section specifies the general methods and requirements of submissions applicable to Shop Drawings, Product Data, Construction Photographs, and Construction or Submittal Schedules. Additional general submission requirements are contained in Article 7.16 of the General Conditions. Detailed submittal requirements are specified in the technical Sections. A preliminary list of shop drawings is included in Part 2.
- B. All submittals shall be clearly identified by reference to Section Number, Paragraph, Contract Map number or Detail as applicable. Submittals shall be clear and legible and of sufficient size for presentation of data.
1. Submittals are categorized into two types: Action Submittals and Informational Submittals
Action Submittal: Written and graphic information submitted by the Contractor that requires the Engineer's approval. The following are examples of action submittals:
 - a. Shop drawings (including working drawings, product data, and signage)
 - b. Schedule of values
 - c. Payment application format
 2. Informational Submittal: Information submitted by the Contractor that does not require the Engineer's approval. The following are examples of informational submittals:
 - a. Shop Drawing Schedule
 - b. Construction Schedule
 - c. Two-Week Lookahead Schedules
 - d. Statements of Qualifications
 - e. Health and Safety Plans
 - f. Construction Photography and Videography
 - g. Work Plans
 - h. Maintenance of Traffic Plans
 - i. Test Records and Reports
 - j. Certifications
 - k. Record Information
 - l. Record Shop Drawings
 - m. Submittals required by laws, regulations and governing agencies
 - n. Submittals required by funding agencies
 - o. Other requirements found within the technical specifications
 - p. Warranties and Bonds
 - q. Contract Close-out Documents

1.02 RELATED WORK

- A. Additional requirements may be specified in the General Conditions for the Contract.
- B. Additional submittal requirements may be specified in the respective technical Specification Sections.

- C. Requests for Information are included in Section 01038.
- D. Photographic Documentation is included in Section 01322.
- E. Contract Closeout submittals are included in Section 01700.
- F. Project Record Documents are included in Section 01720.

1.03 CONTRACTOR'S RESPONSIBILITIES

- A. All submittals shall be clearly identified as follows:
 - 1. Date of Submission
 - 2. Project Number
 - 3. Project Name
 - 4. Contractor Identification
 - a. Contractor
 - b. Supplier
 - c. Manufacturer
 - d. Manufacturer or supplier representative
 - 5. Identification of the Product
 - 6. Reference to Contract Maps and Details
 - 7. Reference to specification section number, page and paragraph(s)
 - 8. Reference to applicable standards, such as ASTM or Federal Standards numbers
 - 9. An indication of Contractor's approval
 - 10. Contractor's Certification statement
 - 11. Identification of deviations from the Contract Documents, if any
 - 12. Reference to previous submittal (for re-submittals)
 - 13. Made in America (when required by the Contract)
- B. Submittals shall be clear and legible, and of sufficient size for legibility and clarity of the presented data.
- C. Submittal Log: Maintain a log of all submittals. The submittal log shall be kept accurate and up to date. This log should include the following items (as applicable):
 - 1. Description
 - 2. Submittal Number
 - 3. Date transmitted to the Engineer
 - 4. Date returned to Contractor (from Engineer)
 - 5. Status of Submittal (Approved/Not Approved/etc.)
 - 6. Date of Resubmittal to Engineer and Return from Engineer (if applicable and repeat as necessary)
 - 7. Date material released for fabrication
 - 8. Projected (or actual) delivery date
- D. Numbering System: Utilize the following submittal identification numbering system:

1. The first character shall be a D, S, M or I which represents Shop Drawing (including working drawings and product data), Sample, Manual (Operating & Maintenance) or Informational, respectively.
2. The next five digits shall be the applicable Section Number.
3. The next three digits shall be the sequential number of each separate item or drawing submitted under each Specification Section, in the chronological order submitted, starting at 001.
4. The last character shall be a letter, A to Z, indicating the submission (or resubmission) of the same submittal, i.e., "A" = 1st submission, "B" = 2nd submission, "C" = 3rd submission, etc. A typical submittal number would be as follows:
 - a. D-03300-008-B.
 - b. D = Shop Drawing
 - c. 03300 = Section for Concrete.
 - d. 008 = the eighth different submittal under this Section.
 - e. B = the second submission (first resubmission) of that particular shop drawing.
5. Submittals that are not cataloged as described in this Section will not be reviewed by the Engineer and will be immediately returned to the Contractor for resubmittal.

E. Variances

1. Notify the Engineer in writing, at the time of submittal, of any deviations in the submittals from the requirements of the Contract Documents.
2. Notify the Engineer in writing, at the time of re-submittal (resubmission), of all deviations from previous submissions of that particular shop drawing, except those deviations which are the specific result of prior comments from the Engineer.

F. Submit all of the data and documents required by the Contract Documents (unless specified otherwise) to the Engineer electronically:

1. Facilitate exchanging information electronically
2. Expedite the review process for submitted documents
3. Centralize Project information

G. Project communications shall be submitted and processed using electronic file sharing and shall be the primary communication tool for all document transfers between the Owner, the Engineer, and the Contractor.

1.04 SHOP DRAWINGS AND PRODUCT DATA

A. Shop Drawings

1. Shop drawings as specified in individual Sections include such items as custom-prepared data such as fabrication and erection/installation (working) drawings, scheduled information, setting diagrams, actual shopwork manufacturing instructions, custom templates, special wiring diagrams, coordination drawings, individual system or equipment inspection and test reports including pump curves and certifications, as applicable to the Work.
2. All shop drawings submitted by subcontractors shall be sent directly to the Contractor for checking. The Contractor shall be responsible for their submission at the proper time so as to prevent delays in delivery of materials.

3. Check all subcontractors' shop drawings regarding measurements, size of members, materials and details to make sure that they conform to the intent of the Details and related Sections. Return shop drawings found to be inaccurate or otherwise in error to the subcontractors for correction before submission thereof.
4. All details on shop drawings shall show clearly the relation of the various parts to the main members and lines of the structure and where correct fabrication of the work depends upon field measurements, such measurements shall be made and noted on the drawings before being submitted.
5. Submittals for equipment or material specified under Divisions 2 or 3 shall include a listing of all installations where identical or similar equipment or material has been installed and been in operation or use for a period of at least one year.
6. Delays to construction due to the untimely submission of submittals will constitute inexcusable delays, for which Contractor shall not be eligible for additional cost nor additional contract time. Inexcusable delays consist of any delay within the Contractor's control.

B. Product Data

1. Product data as specified in individual Sections include such items as, standard prepared data for manufactured products (sometimes referred to as catalog data), such as the manufacturer's product specification and installation instructions, availability of colors and patterns, manufacturer's printed statements of compliance and applicability, roughing-in diagrams and templates, catalog cuts, product photographs, standard wiring diagrams, printed performance curves and operational-range diagrams, production or quality control inspection and test reports and certifications, mill reports, product operating and maintenance instructions and recommended spare-parts listing and printed product warranties, as applicable to the work.

C. Test Records and Reports

1. Provide copies of all test records and reports as specified in the various technical specifications.

D. Certifications

1. Provide all material certifications required to meet the federal and state laws as required in the applicable specification sections.

E. Record Information

1. Submit record information in accordance with Section 01720 for each property including electronic information required in Kahua, photographs and scanned copies of all permit applications and approvals.

F. Record Shop Drawings

1. Before final payment is made, furnish one set of record shop drawings to the Engineer. These record shop drawings shall be in conformance with the approved documents and should show any field conditions which may affect their accuracy.
2. Submittals required by laws, regulations and governing agencies.

- a. Prepare and submit all documentation required by state or local law, regulation or government agency directly to the applicable agency. This includes, but is not limited to, notifications, reports, certifications, certified payroll (for projects subject to wage requirements) and other documentation required to satisfy all requirements. Provide to Engineer one copy of each submittal made in accordance with this paragraph.
3. Submittals required by funding agencies
 - a. Prepare and submit all documentation required by funding agencies. This includes, but is not limited to segregated pay applications and change orders when required to allocate funds to different funding sources properly; and certified payrolls for projects subject to wage requirements. Provide one copy of each submittal made in accordance with this paragraph to the Engineer.
- G. Other requirements of the technical Specification Sections
 1. Comply with all other requirements of the technical specifications.

1.05 CONTRACTOR'S CERTIFICATION

- A. Review shop drawings, product data and samples, including those by subcontractors, prior to submission to determine and verify the following:
 1. Field measurements
 2. Field construction criteria
 3. Catalog numbers and similar data
 4. Conformance with related Sections
- B. Each shop drawing, sample and product data submitted by the Contractor shall have affixed to it the following Certification Statement including the Contractor's Company name and signed by the Contractor:

"Certification Statement: by this submittal, I hereby represent that I have determined and verified all field measurements, field construction criteria, materials, dimensions, catalog numbers and similar data and I have checked and coordinated each item with other applicable approved shop drawings and all Contract requirements."

Shop drawings and product data sheets 11-in x 17-in and smaller shall be bound together in an orderly fashion and bear the above Certification Statement on the cover sheet. Submittals presented without a Certification Statement will not be reviewed by the Engineer and will be immediately returned to the Contractor for resubmittal. The cover sheet shall fully describe the packaged data and include a listing of all items within the package. Provide to the Resident Project Representative a copy of each transmittal sheet for shop drawings, product data and samples at the time of submittal to the Engineer.
- C. Notify the Engineer in writing, at the time of submittal, of any deviations in the submittals from the requirements of the Contract Documents.
- D. The review and approval of shop drawings, samples or product data by the Engineer shall not relieve the Contractor from the responsibility for the fulfillment of the terms of the Contract. All risks of error and omission are assumed by the Contractor and the Engineer will have no responsibility therefore.

- E. No portion of the work requiring a shop drawing, sample, or product data shall be started nor shall any materials be fabricated or installed prior to the approval or qualified approval of such item. Fabrication performed, materials purchased or on-site construction accomplished which does not conform to approved shop drawings and data shall be at the Contractor's risk. The Owner will not be liable for any expense or delay due to corrections or remedies required to accomplish conformity.
- F. Project work, materials, fabrication, and installation shall conform with approved shop drawings, applicable samples, and product data.

1.06 SUBMISSION REQUIREMENTS

- A. Make submittals promptly in accordance with approved schedule and in such sequence as to cause no delay in the Work or in the work of any other contractor.
- B. Each submittal, appropriately coded, will be returned within 14 working days following receipt of submittal by the Engineer.
- C. All submittals and RFI's shall be provided to the Engineer via electronic file sharing.
- D. Number of submittals required:
 - 1. Shop Drawings: One (1) PDF submission
 - 2. Product Data: One (1) PDF submission.
 - 3. Samples: Submit the number stated in the respective Sections.
- E. Submittals shall contain:
 - 1. The date of submission and the dates of any previous submissions.
 - 2. The Project title and number.
 - 3. Contractor identification.
 - 4. The names of:
 - a. Contractor
 - b. Supplier
 - c. Manufacturer
 - 5. Identification of the product, with the section number, page and paragraph(s).
 - 6. Field dimensions, verified prior to submission, clearly identified as such.
 - 7. Relation to adjacent or critical features of the work or materials.
 - 8. Applicable standards, such as ASTM or Federal Standards numbers.
 - 9. Identification of deviations from Contract Documents.
 - 10. Identification of revisions on re-submittals.
 - 11. An 8-inch by 3-inch blank space for Contractor and Engineer stamps.
 - 12. Where calculations are required to be submitted by the Contractor, a qualified individual other than the preparer shall have checked the calculations. The submitted calculations shall clearly show the names of the preparer and of the checker.
- F. Submittals may be transmitted by electronic means provided the following conditions are met:
 - 1. The above-specified transmittal form is included.

2. All other requirements specified above have been met including, but not limited to, coordination by the Contractor, review and approval by the Contractor, and the Contractor's Certification.
3. The submittal contains no pages or sheets larger than 11 x 17 inches.
4. The entire submittal is included in a single file.
5. The electronic files shall be in PDF format, the file shall be indexed, bookmarked, searchable and print enabled
6. The Engineer's review time will commence upon receipt of the transmittal with the attached PDF's in proper format.
7. For Submittals that require certification, corporate seal, or professional embossment (i.e., P.E.s, Surveyors, etc.) transmit at least three hard-copy originals to the Engineer. In addition, provide additional photocopied or scanned copies, as specified above, showing the required certification, corporate seal, or professional seal.

1.07 REVIEW OF SHOP DRAWINGS AND PRODUCT DATA

- A. The review of shop drawings will be for general conformance with the design concept and Contract Documents. They shall not be construed:
 1. as permitting any departure from the Contract requirements;
 2. as relieving the Contractor of responsibility for any errors, including details, dimensions, and materials;
 3. as approving departures from details furnished by the Engineer, except as otherwise provided herein.
- B. The Contractor remains responsible for details and accuracy, for coordinating the work with all other associated work and trades, for selecting fabrication processes, for techniques of assembly, and for performing work in a safe manner.
- C. If the shop drawings, data or samples as submitted describe variations and show a departure from the Contract requirements which Engineer finds to be in the interest of the Owner and to be so minor as not to involve a change in Contract Price or Contract Time, the Engineer may return the reviewed drawings without noting an exception.
- D. Submittals will be returned to the Contractor under one of the following codes.
 - Code 1 - "APPROVED" is assigned when there are no notations or comments on the submittal. When returned under this code the Contractor may release the equipment and/or material for manufacture.
 - Code 2 - "APPROVED AS NOTED" This code is assigned when a confirmation of the notations and comments IS NOT required by the Contractor. The Contractor may release the equipment or material for manufacture; however, all notations and comments must be incorporated into the final product.
 - Code 3 - "APPROVED AS NOTED/CONFIRM" This combination of codes is assigned when a confirmation of the notations and comments IS required by the Contractor. The Contractor may, at his own risk, release the equipment or material for manufacture; however, all notations and comments must be incorporated into the final product. This confirmation shall specifically address

each omission and nonconforming item that was noted. Confirmation is to be received by the Engineer within 15 calendar days of the date of the Engineer's transmittal requiring the confirmation.

- Code 4 - "APPROVED AS NOTED/RESUBMIT" This combination of codes is assigned when notations and comments are extensive enough to require a resubmittal of the package. This resubmittal is to address all comments, omissions and non-conforming items that were noted. Resubmittal is to be received by the Engineer within 15 calendar days of the date of the Engineer's transmittal requiring the resubmittal.
- Code 5 - "NOT APPROVED" is assigned when the submittal does not meet the intent of the Contract Documents. The Contractor must resubmit the entire package revised to bring the submittal into conformance. It may be necessary to resubmit using a different manufacturer/vendor to meet the Contract Documents.
- Code 6 - "COMMENTS ATTACHED" is assigned where there are comments attached to the returned submittal which provide additional data to aid the Contractor.

Codes 1 through 5 designate the status of the reviewed submittal with Code 6 showing there has been an attachment of additional data.

- E. Resubmittals will be handled in the same manner as first submittals. On re-submittals, the Contractor shall identify all revisions made to the submittals, either in writing on the letter of transmittal or on the shop drawings by use of revision triangles or other similar methods. The resubmittal shall clearly respond to each comment made by the Engineer on the previous submission.
- F. Additionally, the Contractor shall direct specific attention to any revisions made other than the corrections requested by the Engineer on previous submissions.
- G. The Engineer will not review preliminary submittals that do not conform to the requirements of regular submittals. Any preliminary submittal will count as the first review and additional submittals will be considered resubmittals.
- H. Partial submittals may not be reviewed. The Engineer will be the only judge as to the completeness of a submittal. Submittals not complete will be returned to the Contractor and will be considered "Not Approved" until resubmitted. The Engineer may at his option provide a list or mark the submittal directing the Contractor to the areas that are incomplete.
- I. Repetitive Review
 - 1. Shop drawings and other submittals will be reviewed no more than twice at the Owner's expense. All subsequent reviews will be performed at times convenient to the Engineer and at the Contractor's expense, based on the Engineer's then prevailing rates. The Contractor shall reimburse the Owner for all such fees invoiced to the Owner by the Engineer. Submittals are required until approved.
 - 2. Any need for more than one resubmission, or any other delay in obtaining Engineer's review of submittals, will not entitle Contractor to an extension of the Contract Time.

- J. If the Contractor considers any correction indicated on the shop drawings to constitute a change to the Contract Documents, the Contractor shall give written notice thereof to the Engineer at least seven working days prior to release for manufacture.
- K. When the shop drawings have been completed to the satisfaction of the Engineer, the Contractor shall carry out the construction in accordance therewith and shall make no further changes therein except upon written instructions from the Engineer.

1.08 DISTRIBUTION

- A. Distribute electronic reproductions of approved shop drawings and copies of approved product data and samples, where required, to the job site file and elsewhere as directed by the Engineer. The recipients of electronic copies shall be as directed by the Engineer.

1.09 PROFESSIONAL ENGINEER (P.E.) CERTIFICATION FORM

- A. If specifically required in other related Sections, submit a P.E. Certification for each item required, in the form attached to this Section, completely filled in and sealed.

1.10 ELECTRONIC FILE SHARING REQUIREMENTS

- A. The online submittal exchange platform, Kahua, will be hosted by the Engineer. The Contractor will be provided two licenses as part of this project. Any additional licenses can be purchased by the Contractor at a cost of \$1,200 per year per license.
- B. All data entered into the electronic file sharing site or service shall be the Owner's sole property.
- C. The Contractor shall be responsible for the validity of the information placed on the electronic file sharing site or service and their personnel's ability to use the application.
- D. The Contractor is responsible for training their personnel in the use of the electronic file sharing site or service.
- E. Any costs associated with using the electronic file sharing site or service system shall be evenly distributed in the Project overheads; a separate added cost shall not be allowed.
- F. Notify the Engineer immediately about any users who no longer are permitted access to the electronic file sharing site or service. Their user account shall be deactivated.
- G. Protect the electronic file sharing site or services security by limiting access to authorized users only and not allowing them to share usernames and passwords.
- H. Comply with the applicable laws and regulations regarding the electronic transmission of documents requiring the stamps or signatures of professional architects, professional engineers, geologists, and surveyors including any provisions to provide of hard copies of such documents as appropriate.
- I. The Contractor, their representatives, users, sub-consultants, and subcontractors shall not enter, attach, or store sensitive personal information such as Social Security numbers in the electronic file sharing site or service.

- J. Project Communications requiring an authorized person’s signature shall use either of the following:
1. An approved image of the official signature to be affixed to the document with the original signed hard copy/paper document to be provided as well.
 2. An electronic copy or electronic image of a fully executed document containing the required signatures with the original signed hard copy/paper document to be provided as well.

PART 2 PRODUCTS

2.01 PRELIMINARY SHOP DRAWING LIST

- A. The below submittals are required to be submitted as part of this project. No scheduling of replacements shall be made until the noted submittals are approved. Additional submittals throughout the specifications are conditional and are required if the conditions apply. The list is not intended to be comprehensive and final. Submittals required in other sections of the specifications are required whether or not included in this list:

<u>Section</u>	<u>Submittal Topic</u>
Procedures and Informational	
01010	Permits
01014	Proposed Notification and Construction Sequence*
01026	Applications for Payment
01045	Cutting, Coring and Patching*
01046	Hydrant Meter with backflow preventer setup
01170	All names of all employees working on the project*
01170	Updated BCI screening*
01300	Contact List / Emergency Contacts*
01300	Health & Safety Plan*
01300	Schedule of submittals*
01310	Baseline construction schedule*
01310	Two week look aheads (initial)*
01322	Pre and post-construction photographs for each property
01370	Schedule of values
01410	Independent testing lab*
01576	Traffic control submittals*
02140	Dewatering and drainage*
02151	General drawing for utility impact moling set up*
02151	Utility impact moling equipment to be used*
02213	Rock and boulder excavation (if needed)
02221	Trenching (if sheeting and bracing is needed)
02221	Backfilling and compaction*
02311	Excavation support and protection (if needed)
02663	Electrical grounding*
02768	General drawing for pipe pulling set up*
02768	Pipe pulling equipment to be used*

Construction Materials

01180	Pipe sleeve*
01180	Sealant*
01180	Swell Strip*
01180	Insulation tape*
01180	Epoxy/ grout*
01180	Mechanical sleeve*
01580	Project sign*
01720	iPad for RPRs*
02270	Sedimentation and erosion control products*
02330	Granular fill materials*
02330	Warning tape*
02576	Pavement repair*
02616	Ductile Iron pipe*
02616	Ductile Iron fittings*
02663	Copper fittings*
02663	Type K Copper*
02663	Curb Box*
02663	Curb Box stainless steel rod*
02663	Corporation Stop*
02663	Curb Stop*
02663	Electrical grounding clamps*
02663	AIS Certification (Curb box, Curb box stainless steel rod, pipe hangers and supports, ductile iron pipe, reinforcing steel)*
02930	Site restoration materials and seed mixtures*
03301	Concrete*
03301	Reinforcing steel*
15410	Interior – Copper Pipe (if different than exterior pipe)*
15410	Interior – Valves*
15410	Interior – Backflow Preventer (Dual Check)*
15410	Interior – Backflow Preventer (RPZ)*
15410	Interior – Pipe hangers and supports*
15410	Interior – Expansion Tank*
15410	Interior – Solder*
BABAA Certification	For iron and steel, manufactured products, and non-ferrous construction materials (non-ferrous metals, plastic and polymer-based products, glass, lumber, drywall; excludes cement and cementitious materials, aggregates, aggregate binding agents, flora, and non-permanent items)*

Any submittal on the above list marked with “*” shall be submitted and approved prior to scheduling any work with homeowners. Allowable timeframes for submittal review stated herein shall be accounted when providing the submittals.

2.02 SOFTWARE

- A. For the duration of the project, Kahua will be maintained by the Engineer for submission of shop drawings, RFIs, and field data such as quantities and schedules. Contractor to obtain licenses in accordance with Paragraph 1.10.
- B. Access to the electronic file sharing site or service shall be provided to allow for submitting and processing documents including, but not limited to, letters, shop drawings, submittals, meeting minutes, daily reports, drawings, Specifications, quantities, schedules, memoranda, payment requisitions, change order requests, testing reports, warranties, guarantees, and correspondence. Requests for Information (RFIs) shall be directly entered into Kahua and generated by the application unless specified otherwise.
- C. Subcontractors and suppliers shall not have direct access to the electronic file sharing site or service unless approved otherwise by Owner and Engineer. Entering information to be exchanged and transferred between the Contractor and subcontractors and suppliers shall be the Contractor's responsibility.

2.03 INTERNET CONNECTIVITY

- A. The electronic file sharing site or service shall be a web-based environment subject to the Contractor's internet service provider's speed and connectivity issues. The Contractor is responsible for their own connectivity to the internet. The electronic file sharing site or service's response time depends on the user's equipment including processor speed, network interface equipment, internet service provider access speed, etc., and current traffic on the internet.
- B. Owner and Engineer shall not be liable for any delays associated with the usage of the electronic file sharing site or service including, but not limited to, slow response time, down time periods, connectivity problems, or information loss on the Contractor's equipment.
- C. Under no circumstances shall using the electronic file sharing site or service be grounds for a time extension or cost adjustment to the Contract.
- D. The Contractor shall have access to the electronic file sharing site or service, and it shall be operational on the Notice to Proceed date.

2.04 DOWN TIME

- A. If the electronic file sharing site or service system is temporarily unavailable, continue with Project Communications using an alternate secure means (e-mail) or hard copies to transmit and receive Project communications.
- B. Maintain records for all Project communications during the electronic file sharing site or service down time and upload the records to the electronic file sharing site or service when it is operational.
- C. Notify the Owner and Engineer by telephone and/or e-mail when the electronic file sharing site or service is not functional.

PART 3 EXECUTION

3.01 SUBMITTAL SCHEDULE

- A. Provide an initial submittal schedule (if different than what is provided in this Section) at the pre-construction meeting for review by Owner and Engineer. Incorporate comments from Owner or Engineer into a revised submittal schedule.
- B. Maintain the submittal schedule and provide sufficient copies for review by Owner and Engineer. An up-to-date submittal schedule shall be provided at each project progress meeting.

3.02 TRANSMITTALS

- A. Prepare separate transmittal sheets for each submittal. Each transmittal sheet shall include at least the following: the Contractor's name and address, Owner's name, project name, project number, submittal number, description of submittal and number of copies submitted.
- B. Submittals shall be transmitted or delivered directly to the Engineer, as indicated in the Contract Documents or as otherwise directed by the Engineer.

3.03 PROCEDURES

- A. Action Submittals
 - 1. Contractor's Responsibilities
 - a. Coordination of Submittal Times: Prepare and transmit each submittal sufficiently in advance of performing the related work or other applicable activities, or within the time specified in the individual work of other related Sections, so that the installation will not be delayed by processing times including disapproval and resubmittal (if required). Coordinate with other submittals, testing, purchasing, fabrication, delivery and similar sequenced activities. Extensions to the Contract Time will not be approved for the Contractor's failure to transmit submittals sufficiently in advance of the Work.
 - b. The submittals of all shop drawings (including working drawings and product data) shall be sufficiently in advance of construction requirements to allow for possible need of re-submittals, including the specified review time for the Engineer.
 - c. No less than 14 calendar days will be required for Engineer's review time for shop drawings and O&M manuals involving only one engineering discipline. No less than 14 calendar days will be required for Engineer's review time for shop drawings and O&M manuals that require review by more than one engineering discipline. Resubmittals will be subject to the same review time.
 - d. Submittals of operation and maintenance data shall be provided within 14 days of approval of the related shop drawing(s).
 - e. Before submission to the Engineer, review shop drawings as follows:
 - 1) make corrections and add field measurements, as required
 - 2) use any color for its notations except red (reserved for the Engineer's notations) and black (to be able to distinguish notations on black and white documents)
 - 3) identify and describe each and every deviation or variation from Contract documents or from previous submissions, except those specifically resulting from a comment from the Engineer on a previous submission
 - 4) include the required Contractor's Certification statement
 - 5) provide field measurements (as needed)

- 6) coordinate with other submittals
 - 7) indicate relationships to other features of the Work
 - 8) highlight information applicable to the Work and/or delete information not applicable to the Work.
2. Engineer's Responsibilities
 - a. The Engineer will not review shop drawings (including working drawings and product data) that do not include the Contractor's approval stamp and the required certification statement. Such submittals will be returned to the Contractor, without action, for correction.
 - b. Partial shop drawings (including working drawings and product data) will not be reviewed. If, in the opinion of the Engineer, a submittal is incomplete, that submittal will be returned to the Contractor for completion. Such submittals may be returned with comments from Engineer indicating the deficiencies requiring correction.
 - c. If shop drawings (including working drawings and product data) meet the submittal requirements, Engineer will forward copies to the appropriate reviewer(s). Otherwise, noncompliant submittals will be returned to the Contractor without action - with the Engineer retaining one copy.
 - d. Submittals which are transmitted in accordance with the specified requirements will be reviewed by the Engineer within the time specified herein. The time for review will commence upon receipt of submittal by Engineer.
 3. Electronic Transmission
 - a. Action submittals are to be transmitted by electronic means and meet all of the following conditions:
 - 1) The above-specified transmittal form is included.
 - 2) The submittal contains no pages or sheets larger than 11 x 17 inches.
 - 3) The entire submittal is included in a single file.
 - 4) The electronic files are PDF format (with printing enabled).
 4. For Submittals that require certification, corporate seal, or professional embossment (i.e., P.E.s, Surveyors, etc.) transmit three hard-copy originals to the Engineer.

B. Informational Submittals

1. Contractor's Responsibilities
 - a. Number of copies: Submit six copies, unless otherwise indicated in individual Specification sections
 - b. Refer to individual technical Specification Sections for specific submittal requirements.
2. Engineer's Responsibilities
 - a. The Engineer will review each informational submittal within 15 days. If the informational submittal complies with the Contract requirements, Engineer will file for the project record and transmit a copy to the Owner. The Engineer may elect not to respond to Contractor regarding informational submittals meeting the Contract requirements.
 - b. If an informational submittal does not comply with the Contract requirements, Engineer will respond accordingly to the Contractor within 15 days. Thereafter, the Contractor shall perform the required corrective action, including retesting, if needed,

until the submittal, in the opinion of the Engineer, is in conformance with the Contract Documents.

3. Electronic Transmission
 - a. Informational submittals are to be transmitted by electronic means and meet all of the following conditions:
 - 1) The above-specified transmittal form is included.
 - 2) The submittal contains no pages or sheets larger than 11 x 17 inches.
 - 3) The entire submittal is included in a single file.
 - 4) The electronic files are PDF format (with printing enabled).
4. For Submittals that require certification, corporate seal, or professional embossment (i.e., P.E.s, Surveyors, etc.)) transmit three hard-copy originals to the Engineer.

P.E. CERTIFICATION FORM

The undersigned hereby certifies that he/she is a professional engineer registered in the State of Rhode Island and that he/she has been employed by

_____ to design
(Name of Contractor)

(Insert P.E. Responsibilities)

in accordance with Section _____ for the

(Name of Project)

The undersigned further certifies that he/she has performed the design of the _____

_____, that said design is in conformance
(Name of Project)

with all applicable local, state and federal codes, rules, and regulations, and that his/her signature and P.E. stamp have been affixed to all calculations and drawings used in, and resulting from, the design.

The undersigned hereby agrees to make all original design drawings and calculations available to the

(Insert Name of Owner)

or Owner's representative within seven days following written request therefor by the Owner.

P.E. Name

Contractor's Name

Signature

Signature

Address

Title

Address

END OF SECTION

SECTION 01310
CONSTRUCTION SCHEDULING

PART 1 GENERAL

1.01 PROGRAM DESCRIPTION

- A. Within ten days after the effective date of Agreement, provide and submit to the Engineer for approval, the schedule the Contractor plans to maintain in order to construct the work with the time allotted successfully. This Schedule shall be a time-scaled Bar Chart in order of early start and shall account for all the work of the Contractor. In addition to all reasonably important construction activities, the Schedule shall provide for the proper sequence of construction considering the various crafts, purchasing time, submittal approval, material delivery, equipment fabrication, and similar time-consuming factors. Failure to supply the construction schedule on time will be cause for withholding progress payments.
- B. Following receipt by the Engineer of the Schedule, a pre-construction conference will then be held between the Owner, Engineer and Contractor to review and, if necessary, revise the Schedule to afford ample time to perform the work in the proper sequence and construction operations. The Engineer shall approve the schedule in accordance with paragraph 2.05 of the Conditions of the Contract.
- C. The Contractor bears full responsibility for scheduling all phases and stages of the work to ensure its successful execution and completion with the time specified in accordance with all provisions of these Specifications.
- D. Update the Schedule monthly and shall submit it to the Engineer in duplicate. The monthly Schedule update shall include the following items:
 - 1. Activities that are completed or in the process are to be identified.
 - 2. Restraints imposed by material deliveries, precedent activity durations or schedule
 - 3. Actual start and completion dates are to be shown.

1.02 SUBMITTALS

- A. Submit schedules, and revisions including graphics, as specified herein.

PART 2 PRODUCTS

PART 3 EXECUTION

3.01 PROGRESS SCHEDULE

- A. Submit a progress schedule before starting any work, in accordance with Article 2.05 of the General Conditions.
- B. Review the progress schedule with the Engineer periodically. Such review shall be made on a monthly basis or more frequently as required by the Engineer. If the Contractor fails to adhere to any part of the progress schedule, the progress schedule shall be updated by the Contractor to reflect the accurate progress of work.

- C. Also submit a 2-week Look Ahead Schedule as described in Article 3.02 below. Adhere to the Look Ahead Schedule and provide written updates whenever the schedule changes due to weather or any other reason.

3.02 2-WEEK LOOK AHEAD

- A. 2-Week Look Ahead Schedule shall be provided weekly (but no later than 12:00 PM on Friday of each week).
 - 1. At a minimum the 2-week Look Ahead shall have the following items listed in a tabular form:
 - a. Project Name, and project number, Contractors Name
 - b. Detailed day-to-day schedule of the task identified in the overall work schedule
 - c. Identify crew and address for each task
 - d. Identify any outages, closures and control activities
 - e. Start and end dates of the week shall be clearly displayed by days of the week
 - f. Anticipated addresses for lead service line replacements
 - g. Anticipated work areas for traffic control and if required, encouraging new registrants
 - h. Dig safe utility mark-out number
 - i. Hour of day that work will be performed (within a 4 hour window)
 - j. Type of replacement (full, public side only, or private side only) or test pit
 - k. Assumed water main size and material type (i.e., 6-inch cast iron)
 - l. Name of licensed plumber to be utilized
 - m. Proposed method of traffic control
 - n. Whether or not road is under a paving moratorium or anticipated to be under an upcoming paving moratorium
 - 2. Payment to be withheld if weekly updates to the 2-week look ahead are not being provided.

3.03 SCHEDULE UPDATES AND STATUS REPORTS

- A. Provide Monthly Schedule Updates with each application for payment. Unless approved otherwise by the Owner and Engineer, the Date for the Monthly Status Reports shall be the end of the respective payment period.
- B. Prior to generating each month's status report, meet with the Engineer to agree to the percent complete of each network activity.

3.04 DELIVERABLES

- A. Unless approved otherwise by the Engineer, all schedule submittals shall be in electronic format (PDF) and in color on pages no larger than 11-in by 17-in and may be divided into as many separate sheets as required.
- B. 2-Week Look Ahead: Submit one electronic copy (PDF) to the Owner and Engineer.
- C. Monthly Schedule Updates: Submit one electronic copy (PDF) to the Owner and Engineer.

3.05 PROGRESS REPORTING

- A. The Monthly Schedule Update will be discussed at each progress meeting.
- B. The two-week look ahead shall be provided via e-mail every Friday by 12:00 P.M. The Engineer shall provide the Contractor with a distribution list of who this two-week look ahead schedule should be sent to.

3.06 RESPONSIBILITY FOR SCHEDULE COMPLIANCE

- A. Whenever it becomes apparent from the current schedule that delays occurred and the contract completion date will not be met, or when so directed by Owner, submit to the Owner for approval, a written statement of the steps intended to take to remove or arrest the delay in the accepted schedule at no additional cost to the Owner, including:
 - 1. Increase construction manpower in such quantities and crafts,
 - 2. Increase the number of working hours per shift, shifts per day, working days per week,
 - 3. Increase the amount of construction equipment, and/or
 - 4. Reschedule activities to maximize the concurrence of activities and comply with the revised schedule.
- B. If when so requested by the Owner, failure to submit a written statement of the steps intended to take or should fail to take such steps as approved by the Engineer, the Engineer may direct the Contractor to increase the level of effort in manpower (trades), equipment and work schedule (overtime, weekend and holiday work, etc.) to be employed by the Contractor in order to remove or arrest the delay to the accepted schedule and the Contractor shall promptly provide such level of effort at no additional cost to the Owner.

3.07 ADJUSTMENT OF CONTRACT SCHEDULE AND COMPLETION TIME

- A. If the Contractor wants or needs to make changes in their execution of the construction schedule that would affect schedule, the Contractor shall notify the Engineer in writing stating what changes are proposed and the reasons for the changes. If the Engineer approves such changes, the Contractor shall revise and submit a revised schedule for acceptance - without additional cost to the Owner. The schedule shall be adjusted by the Contractor only after prior acceptance of their proposed changes. Adjustments may consist of changing portions of the activity sequence, activity durations, division of accepted activities, or other adjustments as may be accepted by the Engineer; however, the addition of extraneous, non-working activities and activities that add unacceptable restraints to the schedule will not be allowed.
- B. Shop drawings that are not approved on the first submittal will require the addition of network activities for the re-submittals.
- C. Equipment that does not pass the specified tests will require the addition of network activities for the retesting.
- D. The contract completion time will be adjusted only for causes specified in this Contract. In the event the Contractor requests an extension of any contract completion date, the Contractor shall furnish such justification and supporting evidence as the Owner may deem necessary to determine whether the Contractor is entitled to an extension of time under the provisions of this Contract. After receipt of such justification and supporting evidence, the Owner shall perform

an assessment or evaluation of the appropriate change in contract time based upon the currently accepted schedule and on all data relevant to the extension. Inexcusable delays (attributable to the Contractor) and non-critical delays (delays to activities which, according to the schedule, do not affect any contract completion date) shall not be the basis for a change in contract time. The Owner will provide a written recommendation based on its assessment, with a copy to the Contractor. The Contractor shall not change any fixed contract milestones or required completion dates without the approval of the Owner, evidenced by the execution of a contract change order. However, the Contractor should make a note of such requests for changes in contract time in the narrative of monthly schedule status reports.

- E. Each request for a change in any contract completion date shall be submitted by the Contractor to the Owner in accordance with the notification requirements stipulated in the Contract Documents. No time extension will be granted for requests that are not submitted in accordance with the Contract requirements.
- F. Total float in the accepted schedule belongs to the project; i.e., either the Owner or Contractor may take advantage of available total float on a first-come, first-served basis. Therefore, without obligation to extend either the overall completion date or any intermediate completion dates set out in the schedule, the Owner may initiate changes to the work or delay work that absorb available total float existing at the time of the change or delay. Owner-initiated changes or delays that affect the schedule shall be the sole grounds for extending (or contracting) contract completion dates or fixed milestones.

END OF SECTION

SECTION 01322
PHOTOGRAPHIC DOCUMENTATION

PART 1 GENERAL

1.01 SCOPE OF WORK

- A. Furnish all labor, materials, equipment and incidentals required to provide photographic documentation of the Project as specified herein.

1.02 SUMMARY

- A. The section includes administrative and procedural requirements for the following:
 - 1. Land-based preconstruction photographs.
 - 2. Land-based final completion construction photographs.

1.03 RELATED WORK

- 1. Submittal procedures are included in Section 01300.
- 2. Project Record Documents are included in Section 01720.

1.04 REFERENCES

- A. Not Used.

1.05 SUBMITTALS

- A. Digital Photographs land-based: Submit image files within three days of taking photographs.
 - 1. File Format: Minimum 3200 by 2400 pixels, in unaltered original files, uncropped, date and time stamped, in a folder named address and date of photograph, with the following required photos by replacement type:

Replacement Type	Required Photos – Pre-construction	Required Photos – Post-construction
Full Replacement	<ol style="list-style-type: none"> 1. Existing condition upon arrival including adjacent properties, buildings on adjacent properties, existing paving, curb, and sidewalks. One photo should be taken capturing the entire width of the road and taken from across the street from where work is to take place. Additional photos as required to record pre-existing settlement or cracking of adjacent structures or pavements and improvements. 2. Existing materials on either side of curb stop, ensuring the material on each side of the curb stop is clearly visible and label which side on a white board 3. Existing corporation stop 4. Existing curb stop 5. Existing piping at foundation and water meter 6. Existing interior area of work 	<ol style="list-style-type: none"> 1. New connection at corporation stop 2. Materials on either side of curb stop after replacement 3. New curb stop 4. New ball valve(s), piping, water meter connection, service line entering at the foundation, and appurtenances inside home 5. Yard restoration photo 6. Sidewalk restoration photo 7. Photo of street patch 8. Interior area of work post-construction 9. Photo after final paving 10. Photo of pitcher filter
Public Side Only Replacement	<ol style="list-style-type: none"> 1. Existing condition upon arrival including adjacent properties, buildings on adjacent properties, existing paving, curb, and sidewalks. One photo should be taken capturing the entire width of the road and taken from across the street from where work is to take place. Additional photos as required to record pre-existing settlement or cracking of adjacent structures or pavements and improvements. 2. Existing materials on either side of curb stop, ensuring the material on each side of the curb stop is clearly visible and label which side on a white board 3. Existing curb stop 4. Existing corporation stop 	<ol style="list-style-type: none"> 1. New fitting at corporation stop 2. Materials on either side of curb stop after replacement 3. New curb stop 4. Sidewalk restoration photo 5. Photo of street patch 6. Photo after final paving 7. Photo of pitcher filter
Private Side Only Replacement	<ol style="list-style-type: none"> 1. Existing condition upon arrival including adjacent properties, buildings on adjacent properties, existing paving, curb, and sidewalks. One photo should be taken capturing the entire width of the road and taken from across the street from where work is to take place. Additional 	<ol style="list-style-type: none"> 1. Materials on either side of curb stop after replacement 2. New ball valve(s), piping, water meter connection, service line entering at the foundation, and appurtenances inside home 3. Yard restoration photo 4. Sidewalk restoration photo

	<p>photos as required to record pre-existing settlement or cracking of adjacent structures or pavements and improvements.</p> <ol style="list-style-type: none"> 2. Existing materials on either side of curb stop, ensuring the material on each side of the curb stop is clearly visible and label which side on a white board 3. Existing piping at foundation and water meter 4. Existing interior area of work 	<ol style="list-style-type: none"> 5. Interior area of work post-construction 6. Photo of pitcher filter
Test Pit	<ol style="list-style-type: none"> 1. Existing condition upon arrival including adjacent properties, buildings on adjacent properties, existing paving, curb, and sidewalks. One photo should be taken capturing the entire width of the road and taken from across the street from where work is to take place. Additional photos as required to record pre-existing settlement or cracking of adjacent structures or pavements and improvements. 2. Existing materials on either side of curb stop, ensuring the material on each side of the curb stop is clearly visible and label which side on a white board 	<ol style="list-style-type: none"> 1. Yard restoration photo 2. Sidewalk restoration photo

2. The photos of the existing conditions upon arrival, yard restoration, and the street patch should include the address number on the building legible and in clear focus. If no number is visible, then Contractor shall provide a white board and write the address on board with minimum number height of 3-inches.
 3. Provide a whiteboard with the address, replacement type, date of work, materials observed on which side, and identification of private side and public side in all photos where the pipe is exposed. The service line materials should be identifiable in all photos. Remove soil such that visual identification of materials from photos is possible.
 4. Submit digital photographs through leadCAST.
11. Any additional photos shall be provided on a file sharing website such as Dropbox or Google Drive with individual file folders for each address. Organize folders by city, street, and address number, in that order.
 12. At the completion of the project, provide all photos on two, mirrored media storage devices (including USB drives or portable solid-state drives). Package each drive, clearly and indelibly labeled using self-adhesive labels specifically designed for labeling of media storage devices. Include on the label the project name and number, Owner and the time period covered by the photographs contained on the disc.

B. Video Recordings: Submit video recordings within seven days of recording.

File Format: Minimum resolution of 720p (1280 x 720, progressive) in unaltered original files, in a folder named address and date of the video.

1. Submit video recordings in digital video on media storage devices in a format acceptable to Engineer (Mpg, .mov, or MP4).
2. Two, mirrored media storage devices (including USB drives or portable solid-state drives)
3. Package each media storage device, clearly and indelibly labeled using self-adhesive labels specifically designed for labeling of discs or media storage devices. Include on the label the project name program number, Owner and the time period covered by the photographs contained on the disc.

1.06 QUALITY ASSURANCE

- A. Photographs are to clearly show the Work. Exhibit correct exposure and focus, accurate color balance, maximum depth of field, minimal optical distortion, and minimal noise.

1.07 USAGE RIGHTS

- A. All photos taken for the purpose of documenting construction and project related work are to be the Owner's property for unlimited reproduction of photographic documentation.

PART 2 PRODUCTS

2.01 PHOTOGRAPHIC MEDIA

- A. Provide digital photographs produced by a digital camera.
- B. Digital Camera: Have a minimum image resolution of twelve (12) megapixels and produce images in JPEG (.JPG) format with image dimensions of not less than 3200 by 2400 pixels.

2.02 DIGITAL VIDEO RECORDINGS:

- A. Digital Video Camera: Have a minimum resolution of 720p (1280 x 720, progressive).
- B. Provide video recordings in a common digital video format such as.MP4. The minimum resolution of all video files shall be 720p (1280 x 720, progressive).

PART 3 EXECUTION

3.01 CONSTRUCTION PHOTOGRAPHS

- A. General: Expose service line materials from debris and soil such that the materials can be easily identified from photographs. Photographs that, in the Engineer's opinion, do not meet these quality criteria will not be accepted and shall be re-taken at no additional cost to the Owner.
- B. Digital Images: Submit digital images exactly as originally recorded in the digital camera, without alteration, manipulation, editing, or modifications using image-editing software except in the case of captioning the photograph with the address, replacement type, date of work, materials observed on which side, and identification of private side and public side in all photos where the curb stop is exposed.

- C. Pre-construction Photographs: Before starting construction, take photographs of Project site and surrounding properties, including existing items to remain during construction, from different vantage points, as directed by Engineer.
 - 1. Flag excavation areas before taking construction photographs.
 - 2. Provide all photos listed in Section 1.05 above.
- D. Post-Construction Photographs: Duplicate the location of the photo taken for pre-construction or as directed by Engineer. Follow all photo requirements as listed in Section 1.05 above.

3.02 CONSTRUCTION VIDEO RECORDINGS

- A. Video Recordings:
 - 1. Produce bright, clear, sharp pictures with accurate colors and free from distortion, excessive shake, or any other form of picture imperfection. Video recordings that, in the Engineer's opinion, do not meet these quality criteria will not be accepted and shall be re-recorded at no additional cost to the Owner.
 - 2. Display continuous running time and date.
 - B. Pre-construction Video Recording: Before starting excavation, demolition or construction, the Contractor is advised to record video of Project site and surrounding properties from different vantage points. Contractor is advised to record individual videos of each street in the Work Area prior to beginning work. Each video file is to be captioned with its respective street name.
 - C. Post-Construction Videos: Retrace path of preconstruction video or as directed by Engineer.
 - D. Additional Photographs or video: Engineer or Owner may request photographs or videos in addition to photographs specified.
 - 1. Three days' notice will be given, where feasible.
 - 2. In emergency situations, take additional photographs within 24 hours of request.
 - 3. Circumstances that could require additional photographs or videos include, but are not limited to, the following:
- 13. Immediate follow-up when on-site events result in construction damage or losses.
 - 14. Substantial Completion of a major phase or component of the Work.
 - 15. Extra-record photographs at the time of final acceptance.
 - 16. Owner's request for special publicity photographs.

END OF SECTION

SECTION 01370
SCHEDULE OF VALUES

PART 1 GENERAL

1.01 REQUIREMENTS INCLUDED

- A. Submit a Schedule of Values allocated to the various portions of the work, within ten (10) days after the effective date of the Agreement.
- B. Upon request of the Engineer or Owner provide supporting data which will substantiate the correctness of values.
- C. The accepted Schedule of Values shall be used only as the basis for the Contractor's Applications for Payment.

1.02 RELATED REQUIREMENTS

- A. Contract Agreement and General Conditions of the Construction Contract are included in Division 00.
- B. Application for Payment is included in Section 01026.

1.03 FORM AND CONTENT OF SCHEDULE OF VALUES

- A. Type schedule on an 8-1/2-in by 11-in or 8-1/2-in by 14-in white paper; Contractor's standard forms and the automated printout will be considered for approval by the Engineer upon Contractor's request. Identify schedule with:
 - 1. Title of Project and location.
 - 2. Owner and Project Number.
 - 3. Name and Address of Contractor.
 - 4. Contract designation.
 - 5. Date of submission.
- B. The schedule shall list the installed value of the component parts of the work in sufficient detail to serve as a basis for computing values for progress payments during construction.
- C. For each major line item list sub-values of major products or operations under the item.
- D. Each item shall include a directly proportional amount of the Contractor's overhead and profit.
- E. The sum of all values listed in the schedule shall equal the total Contract Sum.
- F. Contractor's Schedule of Values will be acceptable to the Owner as to form and substance if it provides a reasonable allocation of the Contract Price to component parts of the Work.

PART 2 PRODUCTS (NOT USED)

PART 3 EXECUTION (NOT USED)

END OF SECTION

SECTION 01410
TESTING AND TESTING LABORATORY SERVICES

PART 1 GENERAL

1.01 REQUIREMENTS INCLUDED

- A. Employ and pay for services of an Independent Testing Laboratory to perform testing specifically indicated in the Contract Documents and upon approval of the Engineer.
 - 1. Perform all inspections and tests required by the Contract Documents.
 - 2. Perform all inspections and tests required by laws, ordinances, rules, regulations, or orders of public authorities
 - 3. Cooperate with the laboratory to facilitate the execution of its required services.
 - 4. Employment of the laboratory shall in no way relieve Contractor's obligations to perform the work of the Contract.
 - 5. Neither observations by the Engineer, nor inspections, tests, or approvals by other than the Contractor, shall relieve the Contractor from his obligation to perform the work in accordance with the requirements of the Contract Documents.

- B. It is the intent to have a technician from the Independent Testing Laboratory on-site for a minimum of ten (10) days during the duration of construction to perform testing as specified. The cost of this technician to be on-site as specified in Section 01010 and all test reports shall be included in the cost of Bid Item No. 1A or 1B as applicable. No additional payment will be made with respect to this.

1.02 RELATED REQUIREMENTS

- A. Conditions of the Contract: Inspections and testing required by laws, ordinances, rules, regulations, orders or approvals of public authorities.
- B. Respective Sections: Certification of products.
- C. Each Section listed: Laboratory tests required and standards for testing.
- D. Testing Laboratory inspection, sampling, and testing is required for but not limited to the following:
 - 1. Trenching, Backfilling, and Compaction are included in Section 02221.
 - 2. Granular Fill Materials is included in Section 02230.
 - 3. Concrete is included in Section 03301.

1.03 SUBMITTALS

- A. Submit to the Engineer in accordance with Section 01300, the names, location and price list of three (3) testing laboratories that meet the following qualifications.
 - 1. The laboratory shall meet "Recommended Requirements for Independent Laboratory Qualifications," published by American Council of Independent Laboratories.
 - 2. The laboratory shall be authorized to operate in the State of Rhode Island.

3. The laboratory is required to maintain Professional Liability Insurance throughout the project.
4. The laboratory shall submit a copy of the report of inspection of facilities made by Materials Reference Laboratory of National Bureau of Standards during the most recent tour of inspection, with a memorandum of remedies of any deficiencies reported by the inspection.
5. Testing Equipment shall be calibrated at intervals recommended by the equipment manufacturer by devices of accuracy that are traceable to either the National Bureau of Standards or accepted values of natural physical constants.
6. The Engineer will select one (1) of the three (3) qualified testing firms, which the Contractor shall employ during the course of the Contract.

1.04 LABORATORY DUTIES

- A. Cooperate with Engineer and Contractor; provide qualified personnel after due notice.
- B. Perform specified inspections, sampling, and testing of materials and methods of construction:
 1. Comply with specified standards.
 2. Ascertain compliance of materials with requirements of Contract Documents.
- C. Secure and deliver to the laboratory adequate quantities of representative samples of materials proposed to be used and which require testing.
- D. Promptly notify Engineer and Contractor of observed irregularities or deficiencies of work or products.
- E. Promptly (but no longer than two (2) days after work has been completed) submit an electronic report of each test and inspection to Engineer. Each report shall include:
 1. Date Issued.
 2. Project title and number.
 3. Testing laboratory name, address, and telephone number.
 4. Name and signature of the laboratory inspector.
 5. Date and time of sampling or inspection.
 6. Record of temperature and weather conditions.
 7. Date of the test.
 8. Identification of product and specification section.
 9. Location of sample or test in the Project.
 10. Type of inspection or test.
 11. Results of tests and compliance with the Contract Documents.
 12. Interpretation of test results, when requested by Engineer.
- F. Perform additional tests as required by Engineer, Owner or Third Party Inspector.

1.05 LIMITATIONS OF AUTHORITY OF TESTING LABORATORY

- A. The laboratory is not authorized to:
 1. Release, revoke, alter or enlarge on requirements of Contract Documents.
 2. Approve or accept any portion of the work.

3. Perform any duties of the Contractor.

1.06 CONTRACTOR'S RESPONSIBILITIES

- A. Cooperate with laboratory personnel and provide access to work.
- B. Secure and deliver to the laboratory adequate quantities of representational samples of materials proposed to be used and which require testing.
- C. Provide to the laboratory the preliminary design mix proposed to be used for concrete and other materials mixes which require control by the testing laboratory.
- D. Materials and equipment used in the performance of work under this Contract are subject to inspection and testing at the point of manufacture or fabrication. Standard requirements for quality and workmanship are indicated in the Contract Documents. The Engineer may require the Contractor to provide statements or certificates from the manufacturers and fabricators that the materials and equipment provided by them are manufactured or fabricated in full accordance with the standard specifications for quality and workmanship indicated in the Contract Documents. All costs of this testing and providing statements and certificates shall be a subsidiary obligation of the Contractor, and no extra charge to the Owner shall be allowed on account of such testing and certification.
- E. Furnish incidental labor and facilities:
 1. To provide access to work to be tested.
 2. To obtain and handle samples at the project site or at the source of the product to be tested.
 3. To facilitate inspections and tests.
 4. For storage and curing of test samples.
- F. Notify laboratory sufficiently in advance of operations to allow for laboratory assignment of personnel and scheduling of tests.
 1. When tests or inspections cannot be performed after such notice, reimburse Owner for laboratory personnel and travel expenses incurred due to the Contractor's negligence.
- G. Employ and pay for the services of the same or a separate, equally qualified independent testing laboratory to perform additional inspections, sampling, and testing required for the Contractor's convenience.
- H. Arrange for submittals of test results directly from the laboratory to the Engineer.
- I. Payment for all testing and testing laboratory services required by this Section shall be included in the bid items installing of the service line. No additional payment for testing required by this Section shall be made, and the cost shall be deemed to be included in the appropriate bid item. The Contractor shall pay for the laboratory costs directly to the testing firm for all test and subsequent retests as a result of failed tests until the test results meet the requirements of the Contract Documents.

PART 2 PRODUCTS (NOT USED)

PART 3 EXECUTION

3.01 CONTRACTOR'S CONVENIENCE TESTING

- A. Inspection or testing performed exclusively for the Contractor's convenience shall be the sole responsibility of the Contractor.

3.02 COOPERATION WITH TESTING LABORATORY

- A. Representatives of the testing laboratory shall have access to Work at all times. The Contractor shall provide facilities for such access in order that the laboratory may properly perform its functions.

3.03 SCHEDULES FOR TESTING

- A. Establishing Schedule:

1. A technician from the approved Laboratory shall be on-site at all times when backfilling of any trench is occurring and when any temporary and/or final pavement restoration is occurring.
2. By advance discussion with the testing laboratory selected by the Owner, determine the time required for the laboratory to perform tests and to issue each of its findings.
3. Provide all required time within the construction schedule.

- B. Revising Schedule:

When changes of construction schedule are necessary during construction, coordinate all such changes in schedule with the testing laboratory as required.

- C. Adherence to Schedule:

When the testing laboratory is ready to test according to the determined schedule but is prevented from testing or taking specimens due to the incompleteness of the work, all extra costs for testing attributable to the delay may be back-charged to the Contractor and shall not be borne by the Owner.

3.04 TAKING SPECIMENS

- A. All specimens and samples for testing, unless otherwise provided in these Contract Documents, will be taken by the testing laboratory; all sampling equipment and personnel will be provided by the testing laboratory, and all deliveries of specimens and samples to the testing laboratory will be performed by the testing laboratory.

END OF SECTION

SECTION 01500
TEMPORARY FACILITIES

PART 1 GENERAL

1.01 SCOPE OF WORK

- A. The Contractor shall provide any temporary facilities, equipment, utilities and appurtenances specified or necessary to properly complete the work.
- B. Upon removal of any temporary facilities, equipment, or appurtenances, the Contractor shall restore the site, location, structure, etc. to its proper condition and make all necessary repairs acceptable to the Owner.
- C. Security and protection of work, materials, and equipment are the responsibility of the Contractor.
- D. The Contractor shall confine all apparatus, materials, supplies, machinery, and equipment to areas designated or approved by the Owner, and do not unreasonably encumber the premises/work site with such apparatus, materials, supplies, etc. Keep the premises/work site clean, neat and free of litter and promptly remove and dispose of all debris resulting from the operation. Confine operations to the property limits of the Owner and do not infringe upon abutting properties; save the Owner harmless from the claims of any abutting or adjacent property owners for damages resulting from operations. Upon completion of work, completely clean and restore the site to a condition acceptable to the Owner.
- E. Providing equipment and temporary facilities needed to perform and complete the work as required by the Contract Documents is the responsibility of the Contractor. Payment for such will be the sole responsibility of the Contractor.
- F. In situations where the facility is owned by Owner, the Contractor may, within reason, use power, water, and telephone available at the facility. The Owner reserves the right to restrict this use to what is necessary and reasonable.
- G. The Contractor shall provide its own office and storage facilities in the work area, as needed at no additional cost to the Owner.
- H. Contractor shall provide sanitary facilities for the construction crews. Contractor shall not use the bathroom facilities of the property owners.
- I. At the end of each day the Contractor shall remove all debris, stored material, equipment, and generally sweep the site(s), and all excavations shall be paved with temporary bituminous pavement or trench plated. Extensive use of trench plates overnight shall not be allowed.

END OF SECTION

SECTION 01576
TRAFFIC CONTROL

PART 1 GENERAL

1.01 SCOPE OF WORK

- A. Public safety and convenience require the Contractor to provide trained traffic control personnel to direct and control traffic within the location of work under this Contract. Uniformed Police officers shall be used for traffic control. If uniformed police officers are not available, flaggers may be used when approved by the agency having jurisdiction over the road.
- B. Arrange with the Police Department for traffic direction services whenever work is conducted within a roadway or whenever traffic flow is restricted as a result of work performed under this Contract. The Contractor shall also be responsible for coordinating and scheduling with the Police Department whenever work is to be conducted within a roadway or whenever traffic flow is restricted as a result of work performed under this Contract.
- C. The traffic control services required herein are intended to ensure public safety by the direction and control of traffic. Traffic control personnel are not intended to serve as watchmen or security to protect the Contractor's equipment and material or to warn pedestrians of such hazards as open trenches or manholes. It is solely the Contractor's responsibility to guard open excavations by erecting suitable barriers by day and lights by night.
- D. Nothing contained herein shall be construed as relieving the Contractor of any of his/her responsibilities for the protection of persons and property under the terms of the Contract.
- E. All payments to the Uniformed Traffic Officers under this Contract shall be in accordance with the General Laws of the State of Rhode Island and any amendments thereto. On a weekly basis, the Contractor shall submit to the Engineer a summary of the hours each officer provided traffic control services. Owner shall be responsible for reimbursing the Contractor for the cost charged by the jurisdiction for police officers' time, with no markup by the Contractor. Reimbursement for police officers' time within a given month shall coincide with the corresponding month's Payment Application. The Contractor will be responsible for paying the police cost, and the police cost from the City shall be included in the Contractor's voucher for payment without overhead or profit and no other markup. Payment for flaggers will also be paid for in the same manner without overhead or profit under a separate allowance item.
- F. Prior to submitting their bid on the project, contact all agencies having jurisdiction over the project including, but not limited to the City of Providence, and RIDOT in order to determine the traffic control requirements and costs of same. The cost of traffic control is included in appropriate bid item.
- G. Provide the Police Departments with construction schedules on a biweekly basis showing work that requires traffic control. In the event the construction schedule is revised after submittal to the Police Department, the Contractor shall provide at least 24 hours' notice before commencing the unscheduled work.
- H. Contractor shall be responsible for all snow removal and ice control within the construction zone throughout the duration of construction.

- I. No road shall be closed to traffic without the prior consent of the Engineer, local Town or City, or RIDOT, as applicable.
- J. Traffic control, including but not restricted to signing, devices and message board, shall be provided for all openings in roads by the Contractor in accordance with City and State standards.

1.02 REQUIREMENTS

- A. All traffic control work performed by the Contractor shall be in accordance with the Manual on Uniform Traffic Control Devices (latest edition), the latest edition of the Rhode Island Department of Transportation Standard Specifications for Road and Bridge Construction, the Details in Appendix B, and these Specifications. Where reference is made to one of the aforementioned publications, the revision in effect at the time of bid opening shall apply.
- B. Protect the traveling public and personnel by adhering to the requirements of Title 31, The Motor and Other Vehicles Code of the State of Rhode Island. The Contractor shall be liable for any neglect to safeguard the traveling public.
- C. Furnish, install, transport operate, maintain equipment, repair and replace; services, and personnel, with traffic control and protective devices, as required to expedite vehicular traffic flow during construction.
- D. Follow the traffic control requirements shown in the Contract Documents detailing all temporary changes in traffic control equipment, street or road closures, detours, etc. Make every effort to adhere to these requirements. The Owner and Engineer reserve the right to modify traffic control requirements through the course of the Contract.
- E. Remove temporary equipment and facilities when no longer required and restore grounds to original or to specified conditions.
- F. Notify all Customers at least 72 hours in advance of any work that will interfere with access to their residence or place of business.
- G. No road shall be closed to traffic without the prior consent of the Engineer and the Owner.
- H. Traffic control, including but not restricted to signing and devices, shall be provided for all openings in roads by the Contractor in accordance with Owner and State standards.
- I. No roadwork is permitted within the City of Providence between November 15th and April 15th unless otherwise approved in writing by the City's Department of Public Works. Private side only replacements that do not require cutting into the roadway may continue throughout the year.
- J. Special work hour limitations are discussed in Section 01014.

1.03 MINIMUM REQUIREMENTS FOR TRAFFIC CONTROL

- A. Provide for access to all buildings including business and parking areas at all times. This shall include but is not limited to schools, churches, hospitals, urgent care centers, polling stations, and grocery stores. The Contractor shall allow for the maintenance of a minimum of one – 11-foot lane of traffic, in one direction, at all times.

- B. Make every reasonable effort to avoid detours. No detour shall be allowed without prior approval from the Engineer and the Owner. A detailed Traffic Control Detour Plan shall be submitted by the Contractor to the Engineer and Owner showing schedule, signing and control for the proposed detour. Said plan(s) shall be submitted at least five workdays prior to the proposed detour and shall be subject to the review and approval of the Engineer and Owner.
- C. Traffic control and road closings in the City of Providence are under the direct control of the Police Department.
- D. Normal drainage shall be maintained. The pavement shall be maintained in broom-swept clean condition, and all work shall be cleaned up at the close of operations each day.
- E. During non-working hours, all excavations shall be either back-filled or steel-plated, and all roadways shall be kept completely clear of any obstructions to traffic. No barricades shall be left within the roadway at night when work is not in progress.
- F. If the Contractor is notified of hazardous construction practice, violation of a regulation or motor vehicle code or if traffic volumes become excessive, all operations shall be summarily discontinued and immediate corrective action shall be taken to the satisfaction of regulator before work can resume.
- G. In the event an obstruction blocks pedestrian traffic, provide a safe passage area for pedestrians.
- H. When the Contractor will be performing an operation which requires the closing of a lane of traffic, even for brief periods of time, close the lane and so mark it with the necessary Protections. Flagmen shall be placed in advance of all lane closures. Additional flagmen shall be placed anywhere in the work area that trucks or other vehicles enter or leave the traffic stream. The cost of flagmen shall be included in unit price. The local police departments shall determine the number of flagmen which may be required by the Contractor.

1.04 TRAFFIC CONTROL

- A. All traffic control shall be performed in accordance with all Federal, State, and local laws, codes, rules and regulations.
- B. All individuals performing traffic control shall be properly equipped and trained. Where required by the road opening permit or as required by the agencies have jurisdiction over the road a Uniformed Police officer for Traffic Control shall be paid for under the Uniformed Police Traffic Control Allowance (Item 1J) on the Bid Form (Section 00 41 00). Flaggers to be paid for under the Flaggers for Traffic Control Allowance (Item 1K).
- C. A minimum of one trained traffic control person shall be present during all work in public streets. If the setup is such that more than one trained traffic control person is needed to control traffic at any one location, provide the additional personal at no additional cost to the Owner.
- D. Be aware of certain festivals and activities that occur in the local municipality. These activities may cause changes in traffic patterns and road closures. Work with Owner and Engineer and is responsible for being aware of the dates, times and locations of all festivals and activities that may be located in work areas and require adjustments to traffic control and construction schedule. Coordinate all work with Owner and Engineer.

- E. Personal vehicles shall not be permitted to park in the work area or immediately adjacent thereto.
- F. No construction vehicles shall be left on the street overnight unless approved in writing by the municipality having jurisdiction.

1.05 TRAFFIC CONTROL SUBMITTALS

- A. Maintain traffic on affected roads and streets at all times as specified and required for permit approvals.
- B. Work shall not commence until approval has been obtained from the Police Department, the Engineer, and the City's Department of Public Works Traffic Engineering Division. Approval by the Engineer shall be required before the Contractor applies for street occupancy and street opening permits with the Department of Public Works' Engineering Division. The traffic control plans submitted to and approved by the Engineer shall be the basis of the plans submitted with the permit applications to the Department of Engineering. Revise and resubmit the traffic control plans based on the Department of Public Works' Engineering Division comments as required to receive approval for street occupancy and street opening permits. Approval by the Engineer does not assure approval without revision by the Department of Public Works' Engineering Division. All traffic control work and road closures must abide by permits issued by the City's Department of Public Works Traffic Engineering Division.
- C. Prior to submitting the traffic control plans to the Engineer, Contractor is to review its proposed traffic control set-up for each work site and work activity with representatives of the local Police Department having jurisdiction. Obtain input from the Police Department regarding the level of police presence and any work hour restrictions on construction activities at the sites.
- D. The traffic control plans shall indicate:
 - 1. Street right-of-way, traffic flow directions, driveway locations, and other site features.
 - 2. The location and arrangement of all traffic control devices, signs, equipment, and personals.
 - 3. Location where temporary no parking signs will be posted. No parking signs shall be dated for a period longer than five (5) calendar days and shall be posted at least 24 hours in advance of work commencing.
 - 4. Legend and description of symbols used.
 - 5. Arrangement and dimensions of work zones, buffer areas, transition zones, and traffic lanes.
 - 6. Location of bypass pumps, hose, and water hose routes and required hose ramps.
 - 7. Anticipated work schedule, including work hours (start and ending times), dates, and duration.
- E. Modifications to approved traffic control plans shall be submitted for approval before being implemented in the field.
- F. See Section 01010 and Section 01046 for related work.
- G. Provide to the Engineer complete copies of approved street permits for each site per Section 01170 prior to commencing work at each site.

- H. Provide to the Engineer written approval from the Police Department and the Department of Public Works prior to commencing work at each site.
- I. The Engineer shall be copied on all correspondence to and from the Police Department and Department of Public Works Traffic Engineering Division concerning obtaining approval of the traffic control plans.

END OF SECTION

SECTION 01580
PROJECT IDENTIFICATION SIGNS

PART 1 GENERAL

1.01 SCOPE OF WORK

- A. Provide and install, prior to the start of construction, the project sign(s) indicated below.

PART 2 PRODUCTS

2.01 ENVIRONMENTAL INFRASTRUCTURE PROJECT SIGN

- A. In accordance with Rhode Island Drinking Water State Revolving Fund (RI DWSRF) and the Bipartisan Infrastructure Law (BIL) funding signage specifications, two project identification signs, at least eight feet long and four feet high, bearing the emblem of the Department shall be displayed in a prominent location to be discussed at the Pre-Construction Meeting.
- B. The Project Signs shall be constructed as shown on the illustration appended to this specification section. Verify that all information is accurate and current before fabrication of the identification signs.

PART 3 EXECUTION

3.01 INSTALLATION

- A. Signs shall be located at a prominent location in the vicinity of the project selected by the Contractor and approved by the Owner.
- B. All project signs shall be maintained by the Contractor in good condition at all times for the duration of the construction.
- C. Remove all project signs from the construction sites at the conclusion of the work when ordered by the Engineer.

END OF SECTION

PROJECT FUNDED BY

President Joe Biden's

Bipartisan

Infrastructure Law

**INVESTING IN
AMERICA**



Variations and Usage



There is one approved mark associated with the Investing In America logo. To preserve the integrity of the Investing In America logo mark, make sure to apply them correctly. Altering, distorting, or recreating the 'marks' in any way weakens the power of the image and what it represents. Layout and design of signs and communication materials will vary, so care must be taken when applying the logo mark.

Primary Logo Mark

INVESTING IN AMERICA

Colors

The colors, graphics, and fonts used should conform to graphic standards.

COLOR	CMYK	RGB	HEX	PMS
 Blue	83, 48, 0, 48	22 / 68 / 132	#164484	PMS 7687 C
 Red	0, 100, 81, 0	255 / 0 / 49	#FF0031	PMS 185 C
 White	2, 2, 0, 3	242 / 244 / 248	#F2F4F8	Bright White

Investing In America General Guidelines for Logo Applications

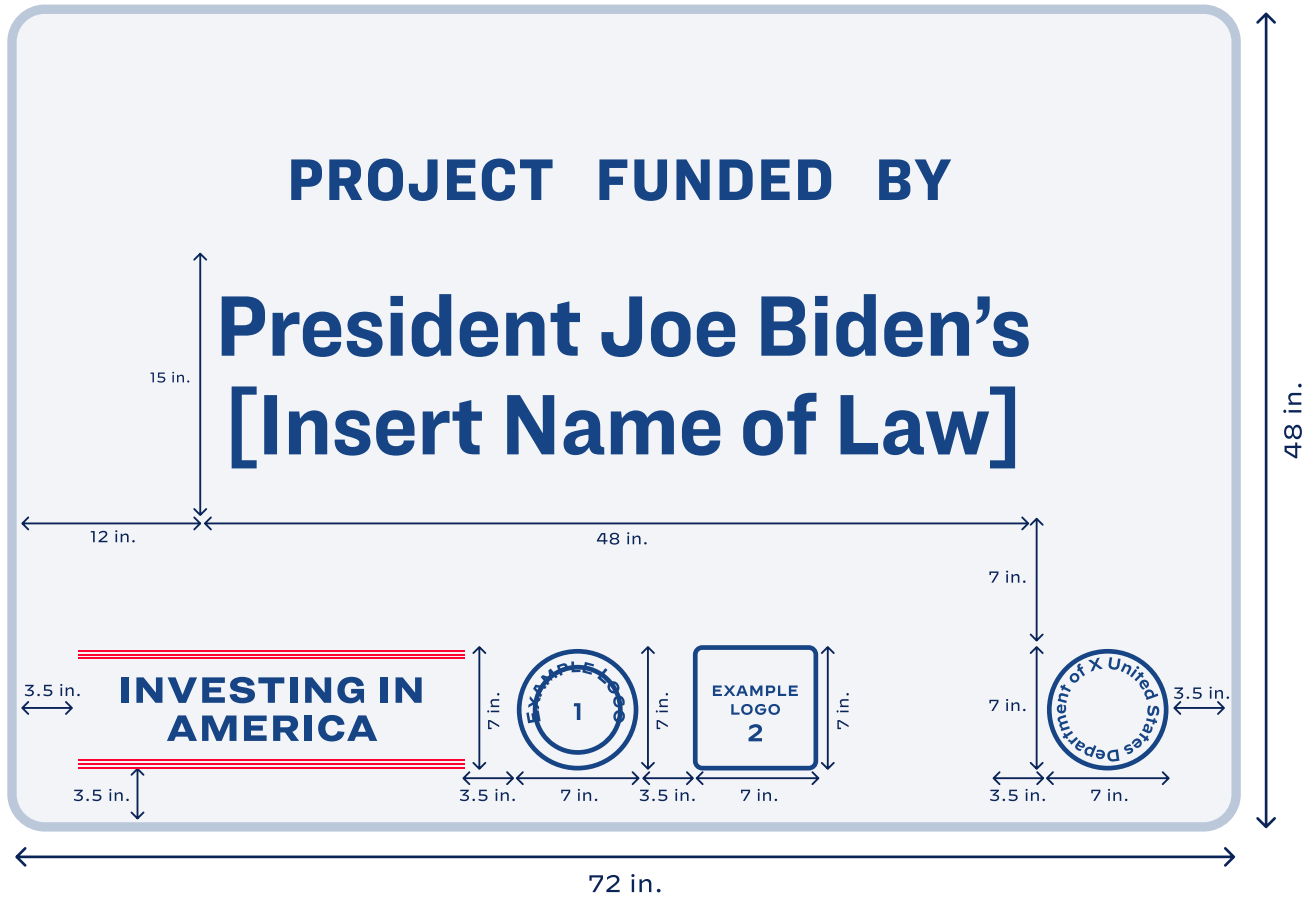

Black

THIS PROJECT IS FUNDED BY THE



Navy Blue

STATE REVOLVING FUND

JOINTLY ADMINISTERED BY THE

Black

Black

**Rhode Island
Infrastructure Bank**

**State of Rhode Island
Department of Health**

Navy Blue



Vahid Ownjazayeri
Board Chair

William J. Fazioli
Executive Director



Daniel J. McKee
Governor

Utpala Bandy, MD, MPH
Director - RI Health



Navy Blue

Navy Blue

"Dedicated To Protecting And Preserving Our State's Most Important Resource...Clean Water"

Grade

Navy Blue

Black

8' - 0"

4' - 0"

A A

THIS PROJECT IS FUNDED BY THE



STATE REVOLVING FUND

JOINTLY ADMINISTERED BY THE

Rhode Island Infrastructure Bank	State of Rhode Island Department of Health	
		
Vahid Ownjazayeri Board Chair	Daniel J. McKee Governor	
William Fazioli Executive Director	Utpala Bandy, MD, MPH Director - RI Health	

"Dedicated To Protecting And Preserving Our State's Most Important Resource...Clean Water"

5"
2"
4"
5"
4"
2"
3"
4"
2"
3"
2"
3"
4"
2"
3"

Grade

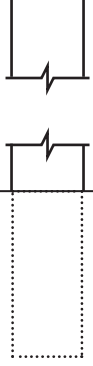

Provide adequate supports for sign as site conditions may require & keep sign a proper distance above prevailing grade to permit public viewing.

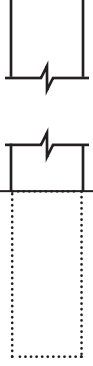

Sign to be extension type high density overlaid plywood or other approved material suitable for signs.

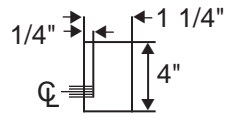

SECTION 01601 CONTROL OF MATERIALS

PART 1 GENERAL

1.01 APPROVAL OF MATERIALS

- A. Unless otherwise specified, only new materials and equipment shall be incorporated in the work. All materials and equipment furnished by the Contractor shall be subject to the inspection and approval of the Engineer. No material shall be delivered to the work without prior approval of the Engineer.
- B. As specified in Section 01300, the Contractor shall submit to the Engineer, data relating to materials and equipment he/she proposes to furnish for the work. Such data shall be in sufficient detail to enable the Engineer to identify the particular product and to form an opinion as to its conformity to the specifications.
- C. Furnish facilities and labor for handling and inspection of all materials and equipment. If the Engineer requires, either prior to beginning or during the progress of the Work, the Contractor shall submit additional samples or materials for such special tests as may be necessary to demonstrate that they conform to the specifications. Such samples shall be furnished, stored, packed and shipped as directed at the Contractor's expense.
- D. Any delay of approval resulting from the Contractor's failure to submit samples or data promptly shall not be used as a basis of a claim against the Owner or the Engineer.
- E. In order to demonstrate the proficiency of workmen or to facilitate the choice among several textures, types, finishes, and surfaces, the Contractor shall provide such samples of workmanship or finish as may be required.
- F. The materials and equipment used on the work shall correspond to the approved samples or other data.
- G. Certify that the purchased products and materials used by the Contractor, subcontractor, material suppliers, and equipment suppliers in the performance of this Contract are in accordance with the "Buy American" provision in Public Law 95-217 (Section 215 of the Public Law 91-500 as amended) and EPA regulations and guidelines. In addition, provide all information required to justify the use of any foreign made product.

1.02 HANDLING AND STORAGE OF MATERIALS

- A. All materials and equipment to be incorporated in the work shall be handled and stored by the manufacturer, fabricator, supplier, and Contractor before, during and after shipment in a manner to prevent warping, twisting, bending, breaking, chipping, rusting and any injury, theft or damage of any kind whatsoever to the material or equipment.
- B. Cement and lime shall be stored under a roof and off the ground and shall be kept completely dry at all times. All structural, miscellaneous, reinforcing steel shall be stored off the ground or otherwise to prevent accumulations of dirt or grease and in a position to prevent accumulations of standing water and to minimize rusting. Flat metal shall be stored vertically. Precast concrete shall be handled and stored in a manner to prevent accumulations of dirt, standing water,

staining, chipping or cracking. Brick, block and similar masonry products shall be handled and stored in a manner to reduce breakage, chipping, cracking and spalling to a minimum.

- C. All mechanical equipment subject to corrosive damage by the atmosphere if stored outdoors (even though covered by canvas) shall be stored in a building to prevent injury. The building may be a temporary structure on the site or elsewhere, but it must be satisfactory to the Engineer.
- D. All materials which, in the opinion of the Engineer, have become so damaged as to be unfit for the use intended or specified shall be promptly removed from the site of the work, and the Contractor shall receive no compensation for the damaged material or its removal.
- E. All pipe and other materials delivered to the job shall be unloaded and placed in a manner that will not hamper the normal operation of the work or interfere with the flow of necessary traffic.

END OF SECTION

SECTION 01700
CONTRACT CLOSEOUT

PART 1 GENERAL

1.01 SCOPE OF WORK

- A. This Section specifies administrative and procedural requirements for project closeout, including but not limited to:
 - 1. Special provisions are included in Section 01170.
 - 2. Submittals are included in Section 01300.
 - 3. Photographic Documentation is included in Section 01322.
 - 4. Project Record Documents are included in Section 01720.

1.02 RELATED WORK

- A. Project deliverables are described in Division 1, 2, 3 and 15.

1.03 PROJECT RECORDS

- A. Maintain in Contractor's office, one set of the following information; actual revisions to work shall be recorded in these documents:
 - 1. Specifications
 - 2. Addenda
 - 3. Change Orders and other Modifications to the Contract
 - 4. Reviewed submittals
 - 5. Contract Maps
 - 6. Details
- B. Record information concurrent with the progress of the Work.
- C. Specifications:
 - 1. Changes made by Addenda and Modifications.
- D. Submit record information and complete service line log documents to Engineer prior to Application for Final Payment.
 - 1. Record information shall be submitted in accordance with as specified in Section 01720.

1.04 CLOSEOUT PROCEDURES

- A. Submit written certification that Contract Documents have been reviewed, work has been inspected, and that work is complete in accordance with Contract Documents and ready for Engineer's inspection.
- B. Provide all deliverables as specified, prior to submitting the final payment application.

- C. Provide submittals to Engineer that are required by governing or other authorities having applicable jurisdiction including but not limited to permit close out information, certificates of occupancy, etc.
- D. Provide evidence that all customer complaints have been addressed.
- E. Provide photographic evidence that final restoration has been completed at each work location.
- F. Submit Application for Final Payment identifying total adjusted Contract Sum, previous payments and sum remaining due. The adjusted Contract Sum shall reflect the actual installed unit quantities as well as other possible adjustments for change orders, liquidated damages, and recovery of engineering fees.
- G. Submit fully executed Contractor's Certificate, Final Release and Release of Liens with a final payment application.
- H. Submit the information required by the Contract, including tabulations and an accurate list and the proof of business registration of each subcontractor or supplier used in the fulfillment of the Contract, or attest that no subcontractor was used.

1.05 FINAL CLEANING

- A. Before requesting the inspection for certification of substantial completion, the Contractor shall complete the following to the extent that the inspection operations left the work area in an unacceptable condition.
 - 1. Clean the project area of rubbish, litter, and other foreign substances. Sweep paved areas broom clean; remove stains, spills and other foreign deposits. Rake grounds that are neither paved nor planted, to a smooth even-textured surface, as necessary.

END OF SECTION

SECTION 01720
PROJECT RECORD DOCUMENTS

PART 1 GENERAL

1.01 SCOPE

- A. Keep and maintain, at the job site, a copy of contract documents, Contract maps, details, photos, service applications and sketches of installed service line marked up to indicate all changes made during the course of a project, as specified herein.
- B. Engineer will maintain the electronic leadCAST database that shall be updated as work progresses. Contractor will add quantities via application provided and the information in the leadCAST database will be compared with the Contractor's pay applications on a weekly and monthly basis. No pay applications will be approved by the Engineer until the quantities match between the Contractor's pay application, leadCAST database and the Engineer's recorded quantities. Neither the Owner or Engineer are responsible for the delay in review and approval of the Contractor's payment application as a result of the Contractor not utilizing leadCAST as specified or in a timely manner.

1.02 RELATED REQUIREMENTS

- A. Submittals are included in Section 01300.
- B. Photographic documentation is included in Section 01322.
- C. Contract Closeout is included in Section 01700.

1.03 REQUIREMENTS INCLUDED

- A. Maintain a record copy of the following documents, marked up to indicate all changes made during the course of a project:
 - 1. Specifications
 - 2. Service applications with information and data for every water service line replaced as specified herein.
 - 3. Swing ties
 - 4. Traffic engineering permits
 - 5. Road opening permits
 - 6. Plumbing permits
- B. Assemble copies of the following documents for turnover to the Owner at the end of the project, as specified.
 - 1. Field Orders, Change Orders, Design Modifications, and RFIs
 - 2. Field Test records
 - 3. Permits and permit close-outs (final approvals)
 - 4. Certificate of Completion, as applicable
 - 5. Laboratory test reports
 - 6. Certificates of Compliance for materials and equipment
 - 7. Record Shop Drawings

8. Material delivery tickets
9. Pre-construction and post-construction photography
10. Service Applications

C. Record Drawings

1. Photographs shall be provided in a file sharing site as required in Section 01322.
2. Provide Providence Water Supply Board standard service application for every water service line replaced. All information on the service applications shall also be tracked in a database as the work progresses.
 - a. Record service applications shall be provided via email, with one file for each service application.
 - b. Service application and database shall include the following information
 - 1) Section A – Applicant Information
 - 2) Section B – Backflow Device Data
 - 3) Section C – Fixture Information
 - 4) Section D – Schedule of Fees (Not applicable for service line replacements)
 - 5) Section E – Disclosures and Signature
 - 6) Site Plan – Proposed
 - 7) Rules and Regulations Governing Water Service Application and Installation
 - 8) Rules and Regulations Governing Water Supplies Used for Fire Service
3. The annotated service applications constitute the Contractor's Record documents and shall be accurate representations of as-built conditions, including all revisions made necessary by change orders, design modifications, requests for information and field orders.
4. Record drawings shall be accessible to the Owner and Engineer at all times during the construction period.
5. Record documents and service applications are considered incidental to the project. Ascertain as-built record information specific to the work, including assistance with the measurements to develop tie-cards produced by the Resident Project Representative.
 - a. Compile record information contemporaneously with construction progress for review and approval on a monthly basis along with pay application. If Engineer determines that the record information provided by the Contractor be inaccurate, incomplete or does not meet the requirements of these Specifications, Engineer will return the information to the Contractor for correction. Contractor shall correct the record information at no additional cost to the Owner and shall resubmit to the Engineer for review and approval. Requirements for as-built record documents and information for the work include:
 - 1) Laboratory test reports (e.g., bacteriological and primary & secondary water quality, soil and concrete test).
 - 2) Legibly mark the Specifications to record the manufacturer, trade name, catalog number, and supplier of each product and item of equipment or material actually installed, as well as any changes made by Field Order, Change Order, RFI, and approved shop drawing.
 - 3) Service applications
6. Record documents shall be stored on-site apart from documents used for construction. Record documents shall not be used for construction purposes. The information submitted by the Contractor in the Record Documents will be assumed to be correct, and the Contractor shall be responsible for the accuracy of such information and shall bear the costs resulting from the correction of incorrect data.

7. The following information shall be provided electronically in the database management system on a daily basis for each property where work is performed:
 - a. Observed pre-construction materials (utility side and private side both interior and exterior)
 - b. Which side of the service is replaced (or if it is a test pit only)
 - c. Record of attempts to reach the homeowner for scheduling the replacement
 - d. Homeowner's information
 - e. New materials used
 - f. Date work scheduled and date work completed
 - g. Contractor name
 - h. Contract number
 - i. Service line length and diameter
 - j. Main diameter
 - k. Depth to service line
 - l. Street surface (for utility side)
 - m. Surface at curb stop
 - n. Measurements for tie-cards
 - o. Up to 10 additional data entries to be specified by the Owner or Engineer

PART 2 PRODUCTS

2.01 EQUIPMENT

- A. The Contractor shall provide the equipment necessary to support the Kahua software. This shall include at least one tablet device per construction crew that can utilize a web browser and include a data package that does not require Wi-Fi for connectivity.
- B. The Contractor shall also provide the Owner with two (2) iPads, 10th generation or later, with Verizon cellular service for the Owner and Engineer to use during the project and retain ownership for future phases. iPads shall be the newest version with a 10.9-inch minimum screen and have at least 32 GB of data and an A14 chip. Cellular data shall be paid for by the Contractor for the duration of the contract through Final Completion. iPads shall be provided with a rugged case meant for field work and all-terrain. Case shall be "impact-resistant". iPads shall be provided with a glass screen protector and spare glass screen protector.

PART 3 EXECUTION

3.01 MAINTENANCE OF RECORD DOCUMENTS AND SAMPLES

- A. Store documents and samples in Contractor's field office apart from documents used for construction.
- B. File documents and samples in accordance with the Construction Specifications Institute (CSI) format.
- C. Maintain documents in a clean, dry, legible, condition and good order. Do not use record documents for construction purposes.
- D. Make documents and sample available for inspection by the Engineer or Owner at all times.

- E. All record documents, including service applications, shall be scanned and linked to the correct water service in the database management system.
- F. Up-to-date electronic record documents may be a pre-requisite of processing periodic monthly pay applications if so specified under the section for progress payments.

3.02 RECORD INFORMATION COMPILATION

- A. Do not conceal any work until the required information is acquired.
- B. Items to be recorded include, but are not limited to:
 - 1. Location of utilities and appurtenances concealed in the construction – referenced to visible and accessible features.
- C. Details not indicated on the original Details.
- D. Service Line cards.
- E. Specifications - legibly mark each Section to record:
 - 1. Manufacturer, trade name, catalog number, and Supplier of each product and item of equipment actually installed.
 - 2. Changes made by Field Order, Change Order, RFI, and approved shop drawing.

3.03 SUBMITTAL

- A. Monthly applications for payment will be contingent upon up-to-date Record documents. Contractor is to send weekly updates on replacement item quantities completed at each address. If requested by the Engineer or Owner, provide a copy of the Record documents, or present them for review prior to processing monthly applications for payment.
- B. Upon substantial completion of the work and prior to final acceptance, the Contractor shall finalize and deliver a complete set of Project Record Documents to the Engineer conforming to the construction records of the Contractor. The Project Record Documents shall consist of service applications and corrected and annotated Contract maps. Unless specified otherwise elsewhere, Record Documents shall be both a hard copy of the service applications and in scanned in PDF format.
- C. The information submitted by the Contractor into the Project Record Documents will be assumed to be correct, and the Contractor shall be responsible for the accuracy of such information and shall bear the costs resulting from the correction of incorrect data.
- D. Delivery of record documents for each location is a prerequisite for complete payment of the replacement bid items as specified in Section 01025.
- E. Delivery of a complete compiled set of Project Record Documents to the Owner and Engineer will be a prerequisite to final payment.
- F. Maintain a copy of all books, records, and documents pertinent to the performance under this Agreement for a period of five years following completion of the contract.

END OF SECTION

SECTION 02140
DEWATERING AND DRAINAGE

PART 1 GENERAL

1.01 SCOPE OF WORK

- A. Design, furnish, install, operate, monitor, maintain and remove a temporary dewatering system as required to lower and control water levels at least 2-ft below subgrades of excavations and to permit construction to proceed in-the-dry.
- B. Furnish, maintain and remove temporary surface water control measures adequate to drain and remove surface water entering excavations.
- C. Work shall include the design, equipment, materials, installation, protection, and monitoring of geotechnical instrumentation required to monitor the performance of the dewatering and drainage system as required herein.
- D. Collect and properly dispose of all discharge water from the dewatering and drainage systems. Under no circumstances shall water from dewatering systems be discharged into the existing sewer system without prior approval from the Owner which may include fees and applications.
- E. All discharges from dewatering activities to surface waters, wetlands, vernal habitats, or storm sewers shall be free of sediment. Discharges due to dewatering activities shall be in accordance with local and state regulations and any related permitting fees are to be at the Contractor's expense. Care shall be taken not to damage or kill vegetation by excessive watering or by damaging silt accumulation in the discharge area. If discharges are sediment-laden, techniques shall be employed to remove sediment prior to discharge. A sedimentation basin shall be constructed and used as specified, where necessary, to protect vegetation and to achieve environmental objectives.
- F. Obtain and pay for all permits required for dewatering and drainage systems under the replacement bid items.
- G. Repair damage caused by dewatering and drainage system operations.

1.02 RELATED WORK

- A. Submittals are included in Section 01300.
- B. Testing and Laboratory Services is included in Section 01410.
- C. Trenching, Backfilling and Compaction is included in Section 02221.
- D. Granular Fill Material is included in Section 02230.
- E. Sedimentation and Erosion Control are included in Section 02270.
- F. Pavement Repair and Resurfacing is included in Section 02576.
- G. Loaming and Seeding is included in Section 02930.

1.03 SUBMITTALS

- A. Dewatering and drainage system designs shall be prepared by the Contractor. Contractor shall submit qualifications as required herein.
- B. Submit a dewatering and drainage system design plan.
 - 1. The plan shall include a description of the proposed dewatering system(s) and include the proposed installation methods to be used for dewatering and drainage system(s) elements. The plan shall include equipment, and dewatering system design calculations in the plan.
- C. The plan shall identify the anticipated area influenced by the dewatering system(s) and address impacts to adjacent existing and proposed structures.
- D. Coordinate dewatering and drainage submittals with the excavation and support of excavation submittals. The submittal shall show the areas and depths of excavation to be dewatered.
- E. Do not proceed with any excavation or dewatering activities until the dewatering submittals have been reviewed by the Engineer.

1.04 QUALITY ASSURANCE

- A. Perform all work in accordance with current applicable regulations and codes of all Federal, State and local agencies.
- B. The Contractor shall have at least 5 years of experience with work compatible to the Work specified, employing labor and supervisory personnel who are similarly experienced in this type of Work.

1.05 DESIGN REQUIREMENTS

- A. The Contractor is responsible for the proper design and implementation of methods for controlling surface water and groundwater.
- B. The primary purpose of the groundwater control system(s) is to perform all pipe laying "in-the-dry" and on undisturbed subgrade soils in the areas of the proposed excavations. The Contractor is responsible for lowering the groundwater as necessary to complete construction in accordance with the details and specifications at no additional cost to the Owner.
- C. Design all groundwater control system components to prevent loss of fines from surrounding soils.
- D. The Contractor shall be responsible for damage to properties, buildings or structures, sewers and other utility installations, pavements and work that may result from dewatering or surface water control operations.
- E. Design review and field monitoring activities by the Owner or by the Engineer shall not relieve the Contractor of his/her responsibilities for the work.

1.06 DEFINITIONS

- A. Where the phrase "in-the-dry" is used in this Section, it shall be defined as an excavation subgrade where the groundwater level has been lowered to at least 2-ft below the lowest level of the excavation, is stable with no ponded water, mud, or muck, is able to support construction equipment without rutting or disturbance and is suitable for the placement and compaction of fill material, pipe or concrete foundations.

PART 2 PRODUCTS

2.01 MATERIALS

- A. Piping, pumping equipment and all other materials required to control of surface water and groundwater in excavations shall be suitable for the intended purpose.
- B. Standby pumping systems and a source of standby power shall be maintained at all sites.

PART 3 EXECUTION

3.01 GENERAL

- A. Control surface water and groundwater such that excavation to final grade is made in-the-dry, the natural undisturbed condition of the subgrade soils is maintained and softening and/or instability or disturbance due to the presence or seepage of water does not occur. All construction and backfilling shall proceed in-the-dry and flotation of completed portions of work shall be prohibited.
- B. Methods of groundwater control may include but are not limited to perimeter trenches and sump pumping, perimeter groundwater cutoff, ejectors and combinations thereof.
- C. It is expected that the type of system, and details of the work will have to be varied depending on soil/water conditions at a particular location.
- D. All work included in this Section shall be done in a manner which will protect adjacent structures and utilities and shall not cause loss of ground or disturbance to the pipe bearing soils or to soils which support overlying or adjacent structures.
- E. Locate groundwater control system components where they will not interfere with construction activities adjacent to the work area. Excavations for sumps or drainage ditches shall not be made within or below 1H:1V slopes extending downward and out from the edges of existing or proposed foundation elements or from the downward vertical footprint of the pipe.

3.02 SURFACE WATER CONTROL

- A. Construct surface water control measures, including dikes, ditches, sumps and other methods to prevent, as necessary, flow of surface water into excavations and to allow construction to proceed without delay.
- B. All sewer and storm inlets within construction areas shall be provided with perimeter hay bales or other appropriate siltation control measures. All inlets shall be maintained to allow capture of incoming flow and shall not be blocked.

3.03 EXCAVATION DEWATERING

- A. At all times during construction, provide and maintain proper equipment and facilities to promptly remove and properly dispose of all water entering excavations. Excavations shall be maintained in-the-dry. Groundwater levels shall be kept at least 2-ft below the lowest excavation level.
- B. Excavation dewatering shall maintain the subgrade in a natural undisturbed condition and until the fill, structure or pipes to be built thereon have been completed to such extent that they will not be floated or otherwise damaged by allowing water levels to return to natural elevations.
- C. Pipe, masonry, and concrete shall not be placed in water or be submerged within 24 hours after being installed. Water shall not flow over new masonry or concrete within four days after placement.
- D. In no event shall water rise to cause unbalanced pressure on structures until the concrete or mortar has set at least 24 hours. Prevent flotation of the pipe by promptly placing backfill.
- E. Dewatering shall at all times be conducted in such a manner as to preserve the natural undisturbed condition of the subgrade soils at the proposed bottom of excavation.
- F. If the subgrade of the trench or excavation bottom becomes disturbed due to inadequate dewatering or drainage, excavate below normal grade as directed by the Engineer and refill with structural fill, screened gravel or other material as approved by the Engineer at the Contractor's expense.
- G. It is expected that the initial dewatering plan may have to be modified to suit the variable soil/water conditions to be encountered during construction. Dewater and excavate, at all times, in a manner which does not cause loss of ground or disturbance to the pipe bearing soil or soil which supports overlying or adjacent structures.
- H. Pumping from the dewatering system shall be continuous until pipe or structure is adequately backfilled. Stand-by pumps shall be provided.
- I. Water entering the excavation from precipitation or surface runoff shall be collected in shallow ditches around the perimeter of the excavation, drained to a sump and pumped from the excavation to maintain a bottom free from standing water.
- J. Drainage shall be disposed of in an approved area as specified in Section 01110. Existing or new sanitary sewers shall not be used to dispose of drainage without first obtaining written permission from the local municipality.

3.04 REMOVAL OF SYSTEMS

- A. At the completion of the excavation and backfilling work, and when approved by the Engineer, all pipe, pumps, generators, other equipment and accessories used for the groundwater and surface water control systems shall be removed from the site. All materials and equipment shall become the property of the Contractor. All areas disturbed by the installation and removal of groundwater control systems shall be restored to their original condition.

END OF SECTION

SECTION 02151
UTILITY IMPACT MOLING

PART 1 GENERAL

1.01 SCOPE OF WORK

- A. Furnish all labor, materials, equipment and incidentals required to install and test the water service line piping and appurtenances using pneumatic horizontal boring (aka moling) methods as specified herein.
- B. The Contractor shall be capable of providing crews as needed to complete the work without undue delay.
- C. The Contractor shall be prepared to provide temporary water service to any location that is not completed within the allocated time.
- D. Review and comply with the coordination requirements listed in Section 02663.
- E. Review and comply record-keeping requirements listed in Section 01720.

1.02 RELATED WORK

- A. Trenching, Backfilling, and Compaction is included in Section 02221.
- B. Water Service Connections are included in Section 02663.

1.03 SUBMITTALS

Submit, in accordance with Section 01300, shop drawings for the pneumatic horizontal boring tool, replaceable boring heads, the air compressor.

- A. Submit, prior to the start of work, a typical drawing showing the equipment setup and the size and location of all proposed pits and excavations required to complete the work.
- B. The Owner shall approve or disapprove the Contractor and/or manufacturer based on the submitted information.

1.04 GUARANTEE

- A. All work shall be fully guaranteed by the Contractor for two (2) years from the date of Substantial Completion. During this period, all serious defects discovered by the Customer or Owner shall be removed and replaced in a satisfactory manner by the Contractor at no cost to the Customer or Owner.

PART 2 PRODUCTS

2.01 MATERIAL

- A. Provide and install copper water service line pipe in accordance with Section 02663.

2.02 EQUIPMENT

- A. The pneumatic horizontal boring tool shall be designed and manufactured to force its way through the existing ground by compressing the surrounding soil as it progresses. The unit shall generate sufficient force to compact the existing soil as it progresses.
- B. Sizing of the pneumatic horizontal boring equipment shall be per manufacturer's specifications for the specific diameter pipe and the soil conditions.
- C. The pneumatic horizontal boring tool shall be a reciprocating stepped-cone chisel head with pre-tensioned spring. Compressed air shall repeatedly propel the piston against the rear of the chisel head assembly to compress the pre-tensioned steel spring to propel the tool forward. At the same time, the new water service line, directly attached to the rear of the boring unit shall be pulled forward with the boring unit.
- D. Provide an air compressor with a hose to drive the Mole (20 to 200 cfm at pressure recommended by manufacturer).
- E. Provide continuous in-line lubrication (oil type recommended by manufacturer) between the compressor and the tool (bore head) for optimal performance.
- F. Provide replaceable boring heads (fixed or moving), made adaptable for different soil conditions.

PART 3 EXECUTION

3.01 GENERAL INSTALLATION

- A. Pneumatic horizontal boring shall be conducted in a continuous operation powered by compressed air to propel the tool forward while pulling the new water service pipe at the same time.
- B. Use a launching cradle and an aiming scope to provide accurate bore alignment and grade.

3.02 INSTALLATION PROCEDURE FOR NON-STEERABLE MOLES

- A. Conduct a pre-installation inspection of the property in which moling is proposed in order to become familiarize each specific site condition (i.e., the location of access, length of pipe, conflicting utilities, etc.).
- B. Provide temporary piping in order to maintain water to existing property during pipe moling, if the property will be without water for longer than 8-hours.

- C. Prior to the actual moling and disconnection of existing water service line, the Contractor shall prepare all excavation pits and have all equipment and piping on-site in order to complete the moling operation in a timely fashion.
- D. Curb stop must be excavated before any other excavation takes place to confirm the service line materials on both sides – the public side and the private side.
- E. Excavate access pits as needed along the existing water service line. The number and size of access pits shall be the minimum necessary to allow for satisfactory completion of the work.
- F. Access pits shall be of sufficient size to allow access and proper alignment for moling equipment, operator and installation of new water service line. All excavation shall be fully braced and supported in accordance with Section 02311. Maximum pit sizes for payment are shown on the details. The Mole must be carefully aligned in the insertion pit and advanced along a straight line
- G. Non-steerable Moles shall have a tracking device by which the depth and location of the Mole will be tracked with a walkover receiver. A sonde (beacon probe) shall be placed in a special housing between the “hose whip” (short hose) at the back of the tool and the air supply hose, or in special housing at the nose of the Mole as per manufacturer’s specifications. This allows the operator to determine if the unit is on the correct line path.

3.03 INSTALLATION PROCEDURE FOR STEERABLE MOLES

- A. The moling shall be conducted as a continuous operation. The bore head shall be immovable thus having the continuous tendency to steer. In order to bore approximately straight, the Mole has to be rotated as it advances.
- B. Moling method shall limit vibrations transmitted to the surrounding soils. The peak particle velocity (PPV) shall be limited to 0.5-inches per second (ips).
- C. The accuracy of steerable Moles depends on the accuracy of the tracking system in the Mole and the skill of the operator. The accuracy of a tracking system shall be 2 to 5 percent of the depth. Expected accuracy should be within 1 to 3 inches from designed bore path.

3.04 DEPTH/CLEARANCE

- A. The Mole shall be installed between 3 to 4 ft below grade. A minimum of 2 feet of clearance shall be maintained between the designed bore path and any adjacent existing underground utilities. The new service line shall be installed a minimum of 4-ft and 6-inches below existing grade regardless of existing service line depth.

3.05 TOOL SIZE, ALIGNMENT AND LAUNCHING

- A. The diameter of the Mole shall be determined by the outer pipe diameter. The created bore should be approximately 15 to 25 percent larger in diameter than the product pipe or as recommended by the manufacturer to allow for borehole shrinkage and to reduce the friction between the pipe and the soil.
- B. The Mole shall be placed on the bottom of the insertion access pit and point at the receiving access pit. Due care must be taken to align the Mole in the pit properly.

3.06 AIR SUPPLY

- A. A standard air compressor with silencer shall be used to operate the impact Mole. The operating pressure at the point where the air hose is connected to the Mole should not exceed the manufacturer's recommended value. The air hose should be lightweight, flexible, and collapse resistant. For steerable moling, the hose shall also have a high torsional stiffness.
- B. As soon as the moling operation is complete, connect the new water service line in accordance with Section 02663.

3.07 BORING SPEED

- A. The penetration rate of the Mole will depend on soil conditions and can vary, the maximum penetration rate for non-steerable moling shall be 5 ft/min. The maximum speed for steerable moling shall be according to the manufacturer's recommendation.

3.08 TOOL LUBRICATION

- A. The Mole requires continuous lubrication for optimal performance. Follow the manufacturer's recommendation as to quantity and type of oil.

3.09 FIELD TESTING AND ACCEPTANCE

- A. Flushing and testing of the new service line shall be done in accordance with 02663.

END OF SECTION

SECTION 02213
ROCK AND BOULDER EXCAVATION

PART 1 GENERAL

1.01 SCOPE OF WORK

- A. Furnish all labor, materials, equipment, and incidentals required and excavate and dispose of rock and boulders as specified herein. Furnish acceptable material for backfill in place of the excavated rock to bring the limits of the trench and/or excavation to those required on this project.
- B. Blasting will not be permitted on this project.
- C. Protect existing structures, utilities, roadway, adjacent property, workers, Engineer, Owner, all abutters, and the public from damage or injury from excessive ground vibrations and rock block movements.

1.02 RELATED WORK

- A. Granular Fill Materials are included in Section 02230.
- B. Sedimentation and Erosion Control is included in Section 02270.
- C. Excavation Support and Protection is included in Section 02311.

1.03 SUBMITTALS

- A. Submit, in accordance with Section 01300, at least two weeks prior to commencing excavation that includes rock excavation the following:
 - 1. A description of the means and methods of rock and boulder excavation techniques including size and energy of any impact equipment and chemical properties of any chemical agents to be used for chemical splitting.
 - 2. Name and qualifications of the person(s) responsible for monitoring and reporting rock excavation vibrations.
- B. Review by the Engineer of material submitted by the Contractor shall not relieve the Contractor of responsibility for the accuracy, adequacy, and safety of the rock and boulder excavation, exercising proper supervision and field judgment and producing the results within the limits required by this Section.

1.04 DEFINITIONS

- A. Rock: Any large mass of stone, bedrock, or ledge rock.
- B. Soil Excavation: The removal of earth, including boulder, weathered rock and rock fragment, loose or disintegrated rock, loose or rotted shale, nested stones, hardpan and the like. Soil Excavation shall include all excavation of earth materials including rock excavation.

PART 2 PRODUCTS (NOT USED)

PART 3 EXECUTION

3.01 GENERAL

- A. Vibrations shall be limited to peak particle velocity (PPV) of 0.5-inches per second (ips).

3.02 ROCK EXCAVATION

- A. Rock excavation may be performed by drilling, wedging, sledging, cutting, barring, jackhammering, hoe ramming, expansive chemical splitting, or another similar process in a manner, which does not cause damage to the existing structures, new construction.
- B. Blasting is not allowed.
- C. All rock excavation operations shall comply with the project, state and local noise and dust regulations.
- D. If rock below grade is shattered by rock excavation methods, and if, in the opinion of the Engineer, the shattered rock is unfit for subgrade, the rock shall be removed and the excavation refilled with thoroughly compacted screened gravel or structural fill at no additional cost.

3.03 DISPOSAL OF ROCK

- A. Fragmented rock with dimensions not exceeding 6 inches in any direction may be mixed with common fill and used as common fill in accordance with Section 02230.
- B. Excavated material shall be stacked without excessive surcharge on the excavation or obstructing free access to hydrants and gate valves. Inconvenience to traffic and abutters shall be avoided as much as possible.
- C. Should conditions make it impracticable or unsafe to stack material adjacent to the excavation, the material shall be hauled and stored at a location provided. When required, it shall be rehandled and used in backfilling the trench at no additional cost to the Owner.
- D. Rock and boulder material disposed of by wasting shall be replaced by available surplus suitable soils. Common fill to supply any deficiency of backfill shall be provided at no additional cost.
- E. Unused rock and boulders shall be removed and disposed of off-site.
- F. Provide to the Owner and Engineer the name and address of the facility receiving any unused rock generated during construction. In addition, provide to the Owner and Owner's representative documentation of the facility's commitment to accept the rock and boulders and the facility's intended use.

END OF SECTION

SECTION 02221
TRENCHING, BACKFILLING AND COMPACTION

PART 1 GENERAL

1.01 SCOPE OF WORK

- A. Furnish all labor, materials, equipment, and incidentals required and perform all trenching for pipelines and appurtenances, including drainage, filling, backfilling, disposal of surplus material and restoration of trench surfaces and rights-of-way.
- B. Furnish and place all sheeting, bracing and supports and remove from the excavation all materials which the Engineer may deem unsuitable for backfilling. The bottom of the excavation shall be firm, dry and in all respects, acceptable.
- C. All excavation, trenching and related sheeting, bracing, etc., shall comply with the requirements of OSHA excavation safety standards (29 CFR Part 1926.650 Subpart P) and State requirements. Where a conflict between OSHA and State regulations exists, the more stringent requirements shall apply.
- D. Wherever the requirement for 95 percent compaction is referred to herein, it shall mean "at least 95 percent of maximum density as determined by ASTM D1557".

1.02 RELATED WORK

- A. Testing and Testing Laboratory Services are included in Section 01410.
- B. Dewatering and Drainage are included in Section 02140.
- C. Excavation Support and Protection is included in Section 02311.
- D. Granular Fill Materials are included in Section 02230.
- E. Pavement Repair and Resurfacing is included in Section 02576.

1.03 SUBMITTALS

- A. Submit to the Engineer the sheeting and bracing design as required prior to excavation.
- B. Submit to the Engineer the proposed method of backfilling and compaction prior to excavation.

1.04 SOIL TESTING

- A. At all structures, appurtenances, manholes, pipelines and service connections, prior to the placement of bedding material, initial backfill, concrete work mats, structural fill, granular fill or structural concrete, coordinate with the soils testing laboratory to verify the suitability of the existing subgrade soil and to perform in-place soil density tests as required to verify that the bearing capacity of the subgrade is sufficient. The Engineer shall assess all subgrades below structures prior to the placement and compaction of backfill material.

- B. Materials will be tested and observed as described in the following paragraphs. Cooperate by allowing free access to the work for selection of test materials and observations:
1. Materials to be used in the work shall be tested in accordance with Section 02230.
 2. If field test results are not in conformance with the requirements of these Specifications, costs of re-testing after correction of deficiencies shall be borne by the Contractor.
 3. Earthwork activities performed without properly scheduled inspection are subject to removal and replacement or additional testing as directed by the Engineer at no expense to the Owner.
 4. Testing methods shall comply with the latest applicable ASTM or AASHTO Standards specified.
 5. During the placement of bedding, backfill and fill, the Contractor shall perform in-place soil density testing to confirm that fill material has been compacted in accordance with the requirements of this Section. Such testing will be paid for by the Contractor and included in the bid price for Bid Items 1A and 1B. The Engineer will designate areas to be tested. The approved testing laboratory representative shall be on-site for 10 full days during the course of construction on days selected by the Engineer or Owner and be present during compaction of subgrade and placement and compaction of bedding and backfill. The approved testing laboratory representative shall confirm the suitability of the subgrade of the excavated trench prior to placement of any bedding and backfill.
 6. Materials which have been previously tested may be subjected to further testing from time to time and may be rejected if it is determined that they do not conform to the requirements of these Specifications. Rejected materials shall be removed from the work immediately when so directed by the Engineer, notwithstanding the results of previous testing.
- C. The Engineer or Owner may conduct additional soil testing. Cooperate fully in obtaining the information desired and allowing free access to the work.
- D. Payment for all testing and testing laboratory services required by this Section shall be included in Bid Item Nos. 1A and 1B.

PART 2 PRODUCTS

2.01 GENERAL

- A. Soils and materials designated for use in this Section are specified in Section 02230.
- B. Warning Tape
1. Tape material shall be formulated from 100 percent virgin polyethylene resins. Resins shall be pigmented for chemical stability and resistance to sulfide staining (colorfastness). Tape shall be constructed by the mechanical (non-adhesive) lamination of two plies of three layers blown film in such a manner as to produce a bi-axially oriented structure. The tape shall be able to provide a 700 percent elongation prior to rupture. The warning tape shall be manufactured with a permanent APWA line color pigment at a maximum of every thirty (30) inches along its length, be imprinted with a continuous warning message as follows: "CAUTION: SERVICE WATER LINE BURIED BELOW"
 2. During the backfilling process, all PVC and Ductile Iron water mains, service lines and system appurtenances shall have a continuous warning tape placed in the open trenches or access pits immediately above them and throughout their length at a depth of eighteen (18)

inches above the utility line surface. The tape shall be six (6) inches wide. At tees, tape ends, etc., the warning tape shall be tied together (spliced) with a knot to create a continuous warning tape throughout the length of the pipeline and associated branch lines, appurtenances, etc.

PART 3 EXECUTION

3.01 TRENCH EXCAVATION

- A. All trench excavations shall comply with OSHA Standards.
- B. Trench excavation shall include material of every description and of whatever substance encountered, including brick pavement, rock, and boulders. Where encountered in the trench, rock shall be excavated to a depth of half of the pipe diameter below the pipe, but in no case less than 6-inches below the bottom of the pipe.
- C. Pavement shall be cut with a saw, wheel or pneumatic chisel along straight lines before excavating.
- D. Strip and stockpile topsoil from grassed areas crossed by trenches. At the Contractor's option, topsoil may be otherwise disposed of and replaced, when required, with approved topsoil of equal quality.
- E. Ensure that trenching does not interfere with normal 45 degrees bearing splay of any building foundation.
- F. While excavating and backfilling is in progress, traffic shall be maintained, and all utilities and other property protected as provided in the General Conditions and other Specification Sections.
- G. Do not disturb soil within the branch spread of existing trees or shrubs that are to remain. If necessary to excavate through roots, perform work by hand and cut roots with a sharp axe.
- H. Except where trees are indicated to be removed, trees shall be protected from injury during construction operations. No tree roots over 2 inches in diameter shall be cut without express permission of the Engineer. Trees shall be supported during excavation by any means previously reviewed by the Engineer.
- I. Correct unauthorized excavations as directed at no cost to the Owner.
- J. Trenches shall be excavated to the depth and in widths no larger than the limit described in Section 01046 Control of Work Paragraphs 1.16 and 1.17. The bottom of the excavations shall be firm, dry and free of irregularities lumps, projections and in all respects acceptable to the Engineer.
- K. Excavation and dewatering shall be accomplished by methods which preserve the undisturbed state of subgrade soils. The trench may be excavated by machinery to or just below the designated subgrade, provided that material remaining in the bottom of the trench is no more than slightly disturbed. Subgrade soils which become soft, loose, "quick," or otherwise unsatisfactory as a result of inadequate excavation, dewatering or other construction methods shall be removed and replaced by crushed stone as required by the Engineer at the Contractor's expense.

- L. Clay and organic silt soils are particularly susceptible to disturbance due to construction operations. When excavation is to end in such soils, use a smooth-edge bucket to excavate the last 1-ft of depth.
- M. Service lines in open cut areas are to be laid on well-graded sand bedding; the trench may be excavated by machinery to the normal depth of the pipe provided that the material remaining in the bottom of the trench is no more than slightly disturbed and does not become softened.
- N. The maximum amount of open trench permitted in any one location shall be 100 feet, or the length necessary to accommodate the amount of pipe installed in a single day, whichever is greater. All trenches shall be fully backfilled at the end of each day or, in lieu thereof, shall be covered by recessed heavy steel plates adequately braced pinned and capable of supporting vehicular traffic in those locations where it is impractical to backfill at the end of each day. If the Owner needs to access the corporation or curb stop for a flush and turn-on of the service in the event the Contractor cannot gain access to the property, the trench shall not be plated with a heavy steel plate. The Contractor shall wait for the Owner to arrive on the site and not leave the Customer without water service. Alternately, the Contractor can backfill the service.

3.02 DISPOSAL OF MATERIALS

- A. Excavated material shall be stacked without excessive surcharge on the trench bank or obstructing free access to hydrants and water valves. Inconvenience to traffic and abutters shall be avoided as much as possible. Excavated material shall be segregated for use in backfilling as specified below.
- A. It is expressly understood that all surplus material shall be removed from the site of the work and properly disposed of at the end of each work day. All surplus material shall be transported, stockpiled and disposed of in accordance with all local, state and federal regulations at no additional cost to the Owner.
- B. Should conditions make it impracticable or unsafe to stack material adjacent to the trench, the material shall be hauled and stored at a location provided by the Contractor. When possible, it shall be rehandled and used in backfilling the trench, see paragraph 3.06.

3.03 EXCAVATION BELOW GRADE AND REFILL

- A. Whatever the nature of unstable material encountered or the groundwater conditions, trench drainage shall be complete and effective.
- B. If the Contractor excavates below grade through error or for the Contractor's own convenience, or through failure to properly dewater the trench, or disturbs the subgrade before dewatering is sufficiently complete, Contractor may be directed by the Engineer to excavate below grade as set forth in the following paragraph, in which case the work of excavating below grade and furnishing and placing the refill shall be performed at his own expense.
- C. A 6-inch thick layer of crushed stone shall be placed below the pipe. Select common fill shall then be placed in 6-in layer thoroughly compacted up to the normal grade of the pipe. If directed by the Engineer, crushed stone shall be used for refill of excavation below grade.

3.04 WARNING TAPE

- A. During the backfilling process, all service lines and system appurtenances shall have a continuous warning tape, as specified in Part 2 of this Section, placed immediately above them and throughout their length at a depth of eighteen (18) inches above the utility line surface. The tape shall be six (6) inches wide. At tees, tape ends, etc., the warning tape shall be tied together (spliced) with a knot to create a continuous warning tape throughout the length of the pipeline and associated branch lines, appurtenances, etc.

3.05 BACKFILLING

- A. Contractor shall have a technician from an approved Soils Testing Laboratory on-site in accordance with Section 01410.
- B. As soon as practicable after the pipe has been laid and jointed, backfilling shall begin and thereafter be prosecuted expeditiously. Backfilling shall be in compliance with RIDOT Standard Specifications for Road and Bridge Construction Section 205.03.5.
- C. Where the pipes are laid in streets, the remainder of the trench up to the bottom of Initial Pavement shall be backfilled with compacted backfill as referenced in Appendix B and as specified in Section 02230. At no time shall backfill layers exceed 1-ft.
- D. Water Service Connections in the open cut areas shall be installed on a minimum of a 6-inch bed of well-graded fine aggregate sand and shall be covered with a minimum of 6-inches of well-graded fine aggregate sand.
- E. To prevent movement of all pipes, dumping backfill material into the trench and then spreading will not be permitted until material has been placed and compacted to a level 1-ft over the pipe.
- F. Backfill shall be brought up evenly on all sides. Each layer of backfill material shall be thoroughly compacted by rolling, tamping, or vibrating with mechanical compacting equipment or hand tamping, to tamping to 95 percent compaction according to ASTM D 1557 or 98 percent according to ASTM D 698. If rolling is employed, it shall be by use of a suitable roller or tractor, being careful to compact the fill throughout the full width of the trench.
- G. All percentages of compaction specified herein shall be related to the maximum dry density as established by Method D, ASTM D1557-70, and verified in the field by the Contractor's field/laboratory testing representative utilizing ASTM D1556-68, D2167-66 or an approved nuclear density testing device. Prior to placing the backfill material, at least one (1) laboratory test shall be made on a representative sample to determine gradation and the moisture density characteristics of the proposed material.
- H. Nuclear compaction tests shall be performed by the technician from the Soils Testing Laboratory once per excavation when soil testing lab is on-site, or at the discretion of the Engineer's representative, to confirm the specified compaction is obtained.
- I. Where other methods are not practicable, compaction shall be by use of hand or pneumatic ramming with tools weighing at least 20 lbs. The material being spread and compacted in layers not over 6-in thick. If necessary, sprinkling shall be employed in conjunction with rolling or ramming.

- J. Subject to approval by the Engineer, fragments of ledge and boulders smaller than 6-in may be used in trench backfill provided that the quantity, in the opinion of the Engineer, is not excessive. Rock fragments shall not be placed until the pipe has at least 2-ft of earth cover. Small stones and rocks shall be placed in thin layers alternating with earth to ensure that all voids are completely filled. Fill shall not be dropped into the trench in a manner to endanger the pipe. All other rock, ledge, boulders, and other material unsuitable for backfilling shall be removed from the site and disposed of by the Contractor.
- K. Bituminous paving shall not be placed in backfilling. Frozen material shall not be used under any circumstances.
- L. Do not compact by puddling or water jetting.
- M. Broom and hose-clean road surfaces immediately after backfilling. Employ dust control measures throughout the construction period.

3.06 RESTORING TRENCH SURFACE

- A. Where the trench occurs adjacent to paved streets, in shoulders or sidewalks, thoroughly consolidate the backfill and maintain the surface as the work progresses. If settlement takes place, immediately deposit additional fill to restore the level of the ground.
- B. The surface of any driveway or any other area which is disturbed by the trench excavation and which is not a part of the paved road shall be restored to a condition at least equal to that existing before work began.
- C. In sections where the pipeline passes through grassed areas, and at the Contractor's own expense, remove and replace the sod, or loam and seed the surface as per Section 02930 and to the satisfaction of the Engineer.
- D. Where the trench occurs in paved area, the pavement shall be restored to maintain smooth even grade that matches the adjacent pavement and preconstruction conditions as detailed in Section 02576.

END OF SECTION

SECTION 02230 GRANULAR FILL MATERIALS

PART 1 GENERAL

1.01 DESCRIPTION

- A. Granular fill materials are specified in this Section, but their use for bedding pipe, pavement base, and similar uses are specified in detail elsewhere. The Engineer may order the use of fill materials for purposes other than those specified in other Sections if, in his/her opinion, such use is advisable.
- B. Granular fill materials shall be natural or processed mineral soils, graded crushed stone or gravel obtained from off-site sources. Granular fill materials shall be free of all organic material, trash, snow, ice, frozen soil, or other objectionable materials which may be compressible, or which cannot be properly compacted. Soft, wet, plastic soils which may be expansive, clay soils having a natural, in-place water content in excess of 30 percent, soils containing more than 5 percent (by weight) fibrous organic materials, and soils having a plasticity index greater than 30 shall be considered unsuitable for use as granular fill materials. Granular fill materials shall have a maximum of 1 percent expansion when testing is performed on a sample remolded to 95 percent of maximum dry density (per ASTM D1557) at 2 percent below optimum moisture content under a 100 lbs/sq ft surcharge.

1.02 RELATED WORK

- A. Trenching, Backfilling, and Compaction are included in Section 02221.
- B. Sedimentation and Erosion Control is included in Section 02270.
- C. Pavement Repair and Resurfacing is included in Section 02576.
- D. Loaming and Seeding is included in Section 02930.

1.03 QUALITY ASSURANCE

A. Laboratory Testing

- 1. Engage the soils testing laboratory to perform:

Grain size analyses of the samples to determine their suitability for use as backfill or fill material in conformance to the materials requirements specified herein.

The appropriate Proctor analyses to determine the maximum dry densities required for compaction testing as specified elsewhere in the Contract Documents.

Test results and determinations of suitability shall be delivered to the resident project representative no later than 3 days prior to the placement of backfill or fill materials.

1.04 SUBMITTALS

- A. Submit to the Engineer all laboratory testing and certification prior to any work.

PART 2 PRODUCTS

2.01 BORROW AND AGGREGATE MATERIALS

- A. Common Fill/Granular Backfill: In accordance with State of Rhode Island, Department of Transportation Standard Specifications for Road and Bridge Construction, Subsection M.01.01.
- B. Gravel Borrow: In accordance with State of Rhode Island, Department of Transportation Standard Specifications for Road and Bridge Construction, Subsection M.01.02 and Subsection M.01.09, Table I (Gradation – Percent Passing), Column I. Gravel Borrow shall also include:
 - 1. Bank Run or Plant-Processed Sand and Gravel: in accordance with Subsection M.01.02.1 and meeting the gradation requirements specified in Subsection M.01.09, Table I, Column I(a).
 - 2. Reclaimed and Processed Granular Material: in accordance with Subsection M.01.02.2 and meeting gradation requirements specified in Subsection M.01.09, Table I, Column I(b).
- C. Crushed Stone or Crushed Gravel: In accordance with State of Rhode Island, Department of Transportation Standard Specifications for Road and Bridge Construction, Subsection M.01.09, Table I, Column II.
- D. Pervious Fill: In accordance with State of Rhode Island, Department of Transportation Standard Specifications for Road and Bridge Construction, Subsection M.01.03, Table I, Column IV.
- E. Bedding Material: Bedding material shall be gravel borrow as specified in 2.01 B.1.
- F. Coarse Aggregate for Bituminous Concrete and Portland Cement Concrete: In accordance with State of Rhode Island, Department of Transportation Standard Specifications for Road and Bridge Construction, Subsection M.01.05.
- G. Fine Aggregate for Asphalt or Portland Cement Concrete: In accordance with State of Rhode Island, Department of Transportation Standard Specifications for Road and Bridge Construction, Subsection M.01.08.
- H. Fine Aggregate – Sand: Natural river or bank sand; free of silt, clay, loam, friable or soluble materials, and organic matter; graded according to ASTM C 33; within the following limits:
 - 1. Percent Passing per Sieve Size:
 - No. 4: 95 to 100.
 - No. 8: 80 to 100.
 - No. 16: 50 to 85.
 - No. 30: 25 to 60.
 - No. 50: 10 to 30.
 - No. 100: 2 to 10.
- I. Topsoil: In accordance with State of Rhode Island, Department of Transportation Standard Specifications for Road and Bridge Construction, Sections L.01 and L.02.

- J. Select Common Fill/Unclassified Fill: Select common fill shall be as specified above for common fill/borrow except that the material shall contain no stones larger than 1 inch in its largest dimension.
- K. Flowable Fill/Controlled Low-Strength Material (CLSM)/Controlled Density Fill (CDF) used as backfill in State Highway right-of-ways or as specified in the Drawings, shall be in accordance with State of Rhode Island, Department of Transportation Standard Specifications for Road and Bridge Construction, Section 603.
- L. Suitability of Backfill Material
 - 1. Suitable backfill material is free of stones larger than half the size of the compacted lift as provided for in RI Highway Standards, construction debris, trash frozen soil, and other foreign material. It consists of well graded gravel and sand or processed gravel.
 - 2. Unsuitable backfill materials consist of the following:
 - Inorganic silts and clays;
 - Organic silts;
 - Organic soils including peat, humus, topsoil, swamp soils, mulch, and soils containing leaves, grass, branches, and other fibrous vegetable matter.

PART 3 EXECUTION (NOT USED)

END OF SECTION

SECTION 02270
SEDIMENTATION AND EROSION CONTROL

PART 1 GENERAL

1.01 SCOPE OF WORK

- A. Furnish all labor, materials, equipment, and incidentals required and perform all installation, maintenance, removal, and area cleanup related to sedimentation control work as shown on the Details and as specified herein.

1.02 RELATED WORK

- A. Environmental Protection Procedures are included in Section 01110.
- B. Trenching, Backfilling and Compaction specifications are included in Section 02221.
- C. Granular Fill Materials are included in Section 02230.

1.03 SUBMITTALS

- A. Submit to the Engineer, in accordance with Section 01300 and within 10 days after award of Contract, technical product literature for all commercial products to be used for sedimentation and erosion control.

1.04 QUALITY ASSURANCE

- A. Be responsible for the timely installation and maintenance of all sedimentation control devices necessary to prevent the movement of sediment from the construction site, staging or laydown areas to off-site areas or into the sewer and/or drainage systems. Measures in addition to those shown in the details necessary to prevent the movement of sediment off site shall be installed, maintained, removed, and cleaned up at the expense of the Contractor. No additional charges to the Owner will be considered.
- B. Sedimentation and erosion control measures shall conform to the requirements outlined in the Rhode Island Soil Erosion and Sediment Control Handbook, most recent edition, which are incorporated herein by reference.

PART 2 PRODUCTS

2.01 MATERIALS

- A. Filter Fabric
 - 1. Filter fabric shall be a woven, polypropylene, ultraviolet resistant material such as Mirafi 100X by Mirafi Inc., Charlotte, NC or equal.
- B. Crushed stone shall be as specified in Section 02230 Granular Fill Materials.

PART 3 EXECUTION

3.01 GENERAL

- A. Take sufficient precautions during construction to minimize the runoff of polluting substances such as silt, clay, fuels, oils, bitumen, and calcium chloride into the supplies and surface waters of the State. Special precautions shall be taken in the use of construction equipment to prevent operations that promote erosion.
- B. Prevent the flow or seepage of runoff to catch basins and drainage areas. Drainage shall not be disposed of until silt and other sedimentary materials have been removed. Particular care shall be taken to prevent the discharge of unsuitable drainage to a water supply or surface water body.
- C. Measures for control of erosion must be adequate to assure that turbidity in the receiving water will not be increased more than 10 standard turbidity units (s.t.u.), or as otherwise required by the State or other controlling body, in waters used for public water supply or fishing unless limits have been established for the particular water. In surface water used for other purposes, the turbidity must not exceed 25 s.t.u. unless otherwise permitted.

3.02 INSTALLATION

- A. Construct inlet filters using filter fabric as specified in this Section and as shown in the details. Filter fabric shall be secured to inlet frame with bricks and in a fashion as to minimize impedance on traffic flow.

3.03 MAINTENANCE AND INSPECTIONS

- A. Inspections
 - 1. Make a visual inspection of all sedimentation control devices once per week and promptly before and after every rainstorm.
 - 2. If such inspection reveals that additional measures are needed to prevent movement of sediment to offsite areas or into the vent trench, promptly install additional devices as needed. Sediment controls in need of maintenance shall be repaired promptly.
- B. Device Maintenance
 - 1. Filter Boxes
 - a. Replace crushed stone when it becomes saturated with silt.

3.04 REMOVAL AND FINAL CLEANUP

- A. Once the site has been fully stabilized against erosion, remove sediment control devices and all accumulated silt. Dispose of silt and waste materials in proper manner. Regrade all areas disturbed during this process and stabilize against erosion with surfacing materials.

END OF SECTION

SECTION 02311
EXCAVATION SUPPORT AND PROTECTION

PART 1 GENERAL

1.01 SCOPE OF WORK

- A. The work specified in this Section includes requirements for excavation and support of temporary excavations, and trenches. The Contractor shall design, furnish, install, and maintain a system of supports, including all bracing and associated items, to retain excavations in a safe manner and to control ground movements. Upon completion of the required construction, the system of supports shall be completely removed and the excavation and staging area sites restored as discussed herein.
- B. The work shall include site grading; fencing, barricades and signing; construction staging areas; design and construction of excavation support systems; disposal of excavated material, surface water, and groundwater; backfilling; and site restoration. Work shall include all labor, materials, and equipment required to complete excavation support.
- C. Retain the services of a professional engineer registered in the State of Rhode Island to prepare excavation support and protection system designs and submittals described herein. Work shall include the design, equipment, materials, installation, protection, and monitoring of geotechnical instrumentation required to monitor the performance of the excavation support system as required herein.
- D. All excavations and support systems shall conform to applicable OSHA excavation, trenching, and shoring standards which are contained in the U.S. Code of Federal Regulations 29 (C.F.R.) 1926.650-1926.653, other federal, state or local requirements. In the event of a conflict, comply with the more restrictive applicable requirements.

1.02 RELATED WORK

- A. Dewatering and Drainage are included in Section 02140.
- B. Rock and Boulder Excavation are included in Section 02213.
- C. Trenching, Backfilling, and Compaction are included in Section 02221.
- D. Granular Fill Materials are included in Section 02230.

1.03 SUBMITTALS

- A. Submit to the Engineer in accordance with Section 01300, Shop Drawings and design calculations for the Contractor-designed excavation support system stamped by a Professional Engineer in the State of Rhode Island when excavation support is required per OSHA or State laws.
- B. Shop Drawings shall include:
 - 1. Overall plan layout of the system, indicating clearances, dimensions, material properties, member sizes, locations, spacing and penetrations depth of all members, locations of

various types of lateral supports. Indicate existing and proposed utilities, structures or other obstruction, location and type of instrumentation and monitoring points within the area of influence of the excavation.

2. Wall elevations and locations of all bracing.
 3. Overall sequence of installation and removal of bracing, indicating levels to which the work will be carried out before bracing is installed or removed.
 4. Method of preloading bracing (if required) and the preload for each member, and the method of locking-off the preload. Include detailed drawings of the connections, jacking supports and method of shimming.
 5. Details, layout, arrangement, equipment requirements, and method of construction of the proposed excavation support system.
 6. Procedures for resolving difficulties arising from misalignment of members exposed during excavation, and criteria for implementing those procedures.
- C. Design calculations shall include:
1. Loads on the excavation support system for all stages of excavation, bracing removal, and concrete placement, including material and equipment loads on the adjacent ground during construction.
 2. Design of wall and all bracing members including all details for all stages of construction.
 3. Theoretical deflections of excavation support system and deformation of structures, pipelines, and other improvements located within the area of influence of the excavation.
 4. Submit to the Engineer for review and acceptance, a plan of action to be implemented in the event any threshold value for deformation is reached. The plan of actions shall be positive measures by the Contractor to limit further movement of the wall including but not limited to trenching for struts and wales, placement of granular earth berms against the wall, installation of additional struts, or combinations thereof. The details of the mitigating measures shall include a schedule of implementation, location and/or availability of materials, structural details for all connections to the wall and support elements, and a detailed description of the method of implementation. The Contractor shall be prepared to work 24 hours per day to implement such measures. The remedial work/mitigating measures shall be at no additional cost to the Owner.
- D. Submit quality control measures as required to ensure that the performance of the excavation support system is consistent with the approved shop drawings and the requirements herein.
- E. Submit welder qualifications and weld procedures in accordance with AWS D1.1.
- F. Submit Contractor's and Design Engineer's qualifications as described in herein.
- G. At least one copy of the design shall be maintained at the job site during excavation that includes a plan indicating the sizes, types, and configurations of the materials to be used in the protective system, and the identity of the registered engineer who approved the design.

- H. Do not proceed with any support of excavation or protection activities until the submittal has been approved by the Engineer.
- I. Design Engineer's documentation shall include:
 - 1. On-site inspections of the excavation support system as the systems are constructed.
 - 2. Review of quality control measures and performance data.
 - 3. Certification that the excavation support system is constructed per the applicable design following completion of each support system and following any modifications by Contractor during construction.

1.04 QUALITY ASSURANCE

- A. Regulations: Perform all work in accordance with current applicable regulations and codes of all Federal, State and local agencies.
- B. The Contractor shall have at least 5 years of experience with work compatible with the Work shown and specified, employing labor and supervisory personnel who are similarly experienced in this type of Work.
- C. The Contractor's Design Engineer shall be a Registered Professional Engineer in the State in which the work is located with at least 5 years professional experience in the design and construction of support of excavation systems and shall have completed not less than 5 successful excavation support projects of equal type, size, and complexity to that required for the work.

1.05 DESIGN REQUIREMENTS

- A. The design of temporary excavation support systems is the responsibility of the Contractor. The design calculations and drawings shall be prepared, stamped and signed by a Professional Engineer registered in the State of Rhode Island, who is experienced in designing similar excavation support systems.
- B. Design temporary excavation support systems in accordance with the requirements of this Section. These criteria are the minimum acceptable standards.
- C. All underground utility lines shall be identified, located, and protected from damage or displacement. Utility companies and other responsible authorities shall be contacted to locate and mark the locations and, if they so desire, direct or assist with protecting the underground installation. However, all mark outs of utilities shall be considered by the Contractor as approximate and the Contractor shall be solely responsible for employing prudent techniques to determine the actual location. When required, the Contractor shall obtain an excavation permit from the local authority having jurisdiction prior to the initiation of any excavation work.
- D. Design excavation support systems in accordance with all OSHA requirements and other local and agency requirements.
- E. Design the support system to minimize horizontal and vertical movements and to protect adjacent structures and utilities from damage.

- F. Excavations below the level of the base of any adjacent foundation or retaining wall shall not be permitted unless the design of the excavation and bracing includes an analysis of the stability of the structure supported by the foundation and as necessary, incorporates required bracing/underpinning of the foundation.
- G. For support systems in which bracing is installed between opposite sides of the excavation, design the excavation support of both sides to be nearly the same as feasible.
- H. Where necessary to resist point loads, pipe piles used as soldier piles shall be filled with concrete with a compressive strength not less than 3,000 psi. The strength of the concrete shall not be considered in the design of the pipe pile for bending stress.
- I. Design, install, operate, and maintain groundwater control system to control groundwater inflows, prevent piping or loss of ground, and maintain the stability of the excavation. Refer to the requirements of Section 02140.
- J. Design review and field monitoring activities by the Owner or by the Engineer shall not relieve the Contractor of his/her responsibilities for the work.

PART 2 PRODUCTS

2.01 MATERIALS

- A. Soldier piles and structural steel members shall conform to ASTM A572 or ASTM A242 unless approved otherwise. No members with permanent deformations are to be provided. Members shall not be spliced unless approved by the Engineer.
- B. Pipe piles used as soldier piles shall conform to ASTM A252.
- C. Steel sheet piling shall conform to ASTM A328 or ASTM A572 or ASTM A690 unless approved otherwise.
- D. Liner plates shall be fabricated from structural quality hot-rolled carbon steel sheets or plates conforming to ASTM A1101 with the following minimum properties before cold forming:
 - E. Plates shall be of either the two- or four-flange type, punched for bolting on all sides. Bolt spacing shall be in accordance with the manufacturer's standard spacing and shall be multiples of the plate length so that the plates having the same curvature shall be interchangeable. Bolt numbers and pattern shall be determined by the liner supplier.
- F. Tensile Strength: 42,000 psi
 - 1. Yield strength: 28,000 psi
- G. Concrete shall conform to Section 03301 or ASTM C33 and ASTM C150 unless otherwise approved.
- H. All timber shall be structural grade with a minimum allowable flexural strength of 1100 psi. Timber lagging shall be at least 3 inches thick and free of large or loose knots.

PART 3 EXECUTION

3.01 GENERAL

- A. Commence installation of support system and excavations only after shop drawings have been reviewed and accepted by the Engineer.
- B. All required instrumentation shall be installed and initialized prior to the start of work.
- C. Methods of construction for excavations shall be such as to ensure the safety of the Work, Contractor's employees, Engineer, and Owner's employees and inspectors, the public and adjacent property and improvements, whether public or private.
- D. Before beginning construction at any location of this project, adequately protect existing structures, utilities, trees, shrubs, and other existing facilities. The repair of or compensation for damage to existing facilities shall be at no additional cost to the Owner.
- E. As a minimum, place fencing or suitable barricades, gates, lights, and signs as necessary around the excavations and staging areas to provide for public safety. Provide personnel to serve as flagmen and watchmen.
- F. Install excavation support systems in accordance with the approved shop drawings and applicable permits.
- G. All voids between the excavation support system and earth shall be filled with materials acceptable to the Engineer.
- H. If unstable material is encountered during excavation, all necessary measures shall be taken immediately to contain it in place and prevent ground displacement.
- I. If settlement or deflections of supports indicate that support system requires modification to prevent excessive movements, redesign and resubmit revised shop drawings and calculations to the Engineer at no additional cost to the Owner.
- J. Sufficient quantity of material shall be maintained on site for the protection of work and use in case of accident or emergency.
- K. All welding shall conform to the applicable provisions of ANSI/AWS D1.1.

3.02 PORTABLE TRENCH BOXES

- A. Portable trench boxes or sliding trench shields may be used for the protection of workers only.
- B. Additional excavation, backfilling, and surface restoration required as the result of trench box use shall be at no additional cost to the Owner.
- C. Trench boxes or shields shall be designed, constructed, and maintained to meet acceptable engineering and industry standards.
- D. Shields shall be installed in a manner to restrict lateral or other hazardous movement of the shield in the event of the application of sudden lateral loads.

- E. A copy of the trench box manufacturer's specifications, recommendations, and limitations shall be in written form and maintained at the job site during all excavation work.

3.03 SOLDIER PILES

- A. Install soldier piles with the minimum embedment depths as shown on approved shop drawings.
- B. Driven piles shall be installed with driving shoes where hard driving is anticipated.
- C. For soldier piles installed in predrilled holes, provide casing or other methods of support as necessary to prevent caving of holes and loss of ground.
- D. Predrilled holes for soldier piles shall be backfilled with concrete from the pile tip elevation to the elevation of the bottom of the excavation. The remainder of the predrilled hole shall be backfilled with lean concrete or sand. Concrete strength shall be in accordance with the approved shop drawings.
- E. The predrilled hole diameter shall be sufficient to allow for proper alignment and concrete backfilling of the pile.
- F. Driven soldier piles shall be advanced without the aid of a water jet.
- G. Provide timber lagging of sufficient thickness to withstand earth pressures and in accordance with the approved shop drawings.
- H. Install lagging such that ground loss does not occur between adjacent or below the lowest board. As excavation proceeds, the maximum height of unlagged face of excavation shall not exceed 4 feet. The unlagged face shall not exceed 2-ft if water seeps or flows from the face of the excavation or if the face of the excavation becomes unstable.
- I. As installation progresses, backfill the voids between the excavation face and the lagging. Pack with materials such as hay, burlap, or geotextile filter fabric where necessary to allow drainage of groundwater without loss of ground.

3.04 STEEL SHEET PILING

- A. Install steel sheet piling with the minimum embedment depths as shown on the approved shop drawings.
- B. Drive sheeting in plumb position with each sheet pile interlocked with adjoining piles for its entire length to form a continuous diaphragm throughout the length of each run of the wall, bearing tightly against the original ground. Exercise care in driving so that interlocking members can be extracted without damaging adjacent structures or utilities. The methods of driving, cutting, and splicing shall conform to the approved shop drawings.
- C. Use templates or other temporary alignment facilities to maintain piling line.
- D. Prior to installation, the sheet piles shall be thoroughly cleaned and inspected for defects and proper interlock dimensions. Provide a tool for checking the interlock dimensions.

- E. Each sheet pile shall have sufficient clearance in the interlocks to slide, under its own weight, into the interlock of the sheet pile previously placed.
- F. Excavation shall not be carried in advance of steel sheet piling installation.
- G. Where obstructions are anticipated, pre-excavation or pre-drilling along the sheet pile wall alignment shall be conducted at no additional cost to the Owner. Pre-excavation and pre-drilling shall not extend below the lowest excavation level or into bearing soils for existing or future structures.
- H. Obstructions encountered before the specified embedment for piles shall be removed. Where obstructions cannot be removed, the sheet pile system shall be re-evaluated by the Contractor's Design Engineer for the resulted reduced embedment and additional toe stability measure implemented, as required or for realignment of the sheet pile wall. Submittal of the proposed measures shall be provided.
- I. Damaged piling or piling with faulty alignment shall be withdrawn and new piling driven properly in its place. The cost of such additional work shall be considered as part of the pile driving and shall be borne by the Contractor.

3.05 LINER PLATES

- A. Liner plates shall be installed as soon as excavation has progressed sufficiently for the next ring of plates to be installed. A complete circumferential ring of liner plates shall be installed prior to continuing the excavation. Installing more than one incomplete ring of liner plates at any time is not acceptable. Plates shall be staggered in the vertical direction to facilitate shaft strength and leakage resistance.
- B. Liner plates shall be grouted in accordance with the approved shop drawings.

3.06 INTERNAL BRACING

- A. Provide internal bracing to carry maximum design load without distortion or buckling.
- B. Include web stiffeners, plates, or angles as needed to prevent rotation, crippling, or buckling of connections and points of bearing between structural steel members. Allow for eccentricities caused by field fabrication and assembly.
- C. Install and maintain all bracing support members in tight contact with each other and with the surface being supported.
- D. Coordinate excavation work with the installation of bracing. Excavation shall extend no more than 2 feet below any brace level prior to installation of the bracing.
- E. Use procedures that produce uniform loading of a bracing member without eccentricities or overstressing and distortion of members of the system.

3.07 REMOVAL OF EXCAVATION SUPPORT

- A. Do not remove internal bracing and transfer loads to the permanent structure without prior acceptance of the Engineer.

- B. Removal shall begin at and progress from the bottom of the excavation. Members shall be released slowly as to note any indication of the possible failure of the remaining members or possible cave-in of the sides of the excavation.
- C. Backfilling shall progress together with the removal of support systems from excavations.
- D. Unless otherwise indicated, remove all portions of excavation support.
- E. Do not remove vertical support members that were installed within the zone of influence of new or existing structures. The zone of influence is defined as a zone extending down and away from the outer edge of the structure at 1 horizontal to 1 vertical. Support members installed within this zone shall be cut off at 5 ft below finished grade and abandoned in place.
- F. No untreated wood shall remain as part of the abandoned portion of the work.
- G. When removing the excavation support system, do not disturb or damage adjacent buildings, structures, waterproofing material, or utilities. Fill voids immediately with lean concrete or well-graded cohesionless sand, as indicated or as directed by the Engineer.
- H. Remove material of the excavation support system from the site immediately.

END OF SECTION

SECTION 02576
PAVEMENT REPAIR AND RESURFACING

PART 1 GENERAL

1.01 SCOPE OF WORK

- A. Furnish all labor, material, equipment, and incidentals required and replace all pavement removed over trenches or excavations or otherwise disturbed by the Contractor's operations.
- B. New pavement in streets shall consist of initial pavement over all trenches. Final bituminous concrete pavement shall be placed over trenches and excavations on roads indicated in Appendix C.
- C. Final pavement on streets under moratorium must comply with the paving requirements of the corresponding City Department of Public Works or RIDOT permit issued, which may be infra-red or curb to curb paving. Infra-red paving shall be performed as described in Section 02577.
- D. Streets, driveways, parking areas or sidewalk pavements damaged or disturbed by the Contractor's operations shall be repaired, replaced, or restored in accordance with the requirements specified herein and as directed for the respective type of pavement replacement and in a manner satisfactory to the Owner and City.
- E. Obtain all necessary City and State permits for road opening and comply with all rules and regulations governing road opening permits.
- F. Damage to the pavement outside of the limits of work which, in the opinion of the Engineer, is not necessary to complete the Work and is a result of activities by the Contractor, his laborers, agents or subcontractors shall be repaired in a manner satisfactory to the Engineer, Owner, City and State at the expense of the Contractor.
- G. Limits of pavement and pavement details are shown on the details in Appendix B.

1.02 RELATED WORK

- A. Trenching, Backfilling, and Compaction are included in Section 02221.
- B. Granular Fill Materials are included in Section 02230.
- C. Infra-red Pavement Repair and Patching are included in Section 02577.

1.03 REFERENCE STANDARDS

- A. Except as otherwise specified herein, the current Standard Specifications for Road and Bridge Construction, including all addenda, issued by the State of Rhode Island Department of Transportation (RIDOT), shall apply to materials and workmanship required for the work of this Section.
- B. American Association of State Highways and Transportation Officials (AASHTO)

1. AASHTO M144 - Standard Specification for Calcium Chloride.

- D. Where reference is made to one of the above standards, the revision in effect at the time of bid opening shall apply.

1.04 MAINTENANCE

- A. The CONTRACTOR will be held responsible for any pavement failures due to settlement or failures associated with his excavations, for a period of five (5) years from the date of the pavement's installation and acceptance.
- B. If, at any time during the five (5) year period following final acceptance of paving work under this contract, any part of the paving or surfacing work which, in the opinion of the OWNER, requires replacement, repair, or remedial action to damaged private or public property (caused by any defect in the paving work), the OWNER will require the CONTRACTOR to make the necessary repairs or replacement to the OWNER's satisfaction within ten (10) days of notification.
- C. At the OWNER's discretion, the OWNER may employ other persons to make such repairs and replacement. The CONTRACTOR agrees, upon demand, to reimburse the City all amounts expended for such repairs or replacements.
- D. All material and labor required for such maintenance shall be supplied by the Contractor, and the work shall be done in a manner satisfactory to the Owner at no additional cost to the Owner.
- E. Failure to meet the warranty requirements constitutes a breach of contract.

1.05 SUBMITTALS

- A. Submit to the Engineer, in accordance with Section 01300, design mix for each bituminous material.
- B. Samples: Provide samples of materials for laboratory testing and job mix design.
- C. The following submittals must be furnished for the work of this Section:
1. Certified Mix Designs
 2. Certified Test results for gravel gradation.
- D. Product Data: Submit data on material and equipment to be used in concrete pavement including:
1. Sources of aggregate, manufacturer data sheets for cement and concrete admixtures used in the concrete mix design.
 2. Dowels and dowel bar assemblies.
 3. Reinforcement or welded wire mesh.
 4. Proposed Techniques: submit proposed techniques for placement, consolidation, finishing texturing and curing of concrete.
 5. Concrete Mix Design Data:
 - a. Submit concrete mix design for each concrete strength.
 - b. Identify mix ingredients and proportions, including admixtures.

PART 2 PRODUCTS

2.01 MATERIALS

A. Asphalt Paving

1. Bituminous concrete pavement and bituminous materials shall conform to Section M.03 of the Rhode Island Department of Transportation Standard Specifications for Road and Bridge Construction.
2. Asphalt-Tack coat type, grade, and application methods shall conform to both Section M.03; Materials and Section 403; Asphalt Emulsion Tack Coat of the Rhode Island Department of Transportation Standard Specifications for Road and Bridge Construction.
3. Backfill shall be in accordance with RIDOT Minimum Standards for State and Municipal Road Repair for Utility Work.
4. Initial pavement shall be in accordance with the Rhode Island Department of Transportation Standard Specifications for Road and Bridge Construction and RIDOT Minimum Standards for State and Municipal Road Repair for Utility Work.
5. Temporary pavement marking paint shall be epoxy and thermoplastic markings. Paint shall be white or yellow to match existing conditions or as directed by the Engineer.
6. Final street pavement restoration shall include two (2) inches of micro-milling and resurfacing of all impacted travel lanes and/or shoulders for their full width using Class 9.5 or 12.5 hot mix asphalt (as directed by City permit conditions).

B. Concrete Paving

1. Concrete pavement shall be Class A concrete, as specified in Section 03301, repaired with a minimum of 3,000 psi concrete in accordance with RIDOT Standard Specifications for Road and Bridge Construction, Section 601, Table 2.

C. Permanent pavement marking paint shall be epoxy resin reflectorized traffic paint. Paint shall be white or yellow to match existing conditions or as directed by the Engineer.

D. Concrete sidewalks shall conform to Rhode Island Department of Transportation Standard Specifications for Road and Bridge Construction, Section 905.

E. Concrete curbs shall conform to Rhode Island Department of Transportation Standard Specifications for Road and Bridge Construction, Section 906.

PART 3 EXECUTION

3.01 GENERAL

A. Openings

1. It shall be unlawful for any person or persons, firm, corporation, or municipality to make any excavation in or to open or damage the surface of any road or street under the jurisdiction of the RIDOT, City of Providence or Cranston without written approval from the authority having jurisdiction.
2. No City of Providence Department of Public Works controlled roads can be opened after November 15th or before April 15th. Road work is permitted during winter months in Cranston, North Providence, Smithfield and Johnston as long as temporary road restoration requirements are followed. Road plates may not be left in place after November 15th. The

only exceptions shall be for emergencies declared by the City Department of Public Works.

3. The Contractor shall abide by the hours of construction specified in Section 01014.
4. Notify residents and business 72-hours prior to beginning roadwork.
5. Steel plates are to be used over excavations to permit full traffic flow during non-working hours. No barricades, equipment, materials, or other obstructions to traffic shall be left in the roadway when work is not actually in progress.
6. Provisions shall be made to protect all existing underground utilities during construction. Work shall be conducted to eliminate interference with subsurface utilities and their appurtenances unless permission for interference has been obtained from the proper authorities.
7. All roadways shall be cleanly saw cut before excavation is made.
8. After an opening is made, the work shall be continuous, and restoration of disturbed surfaces shall be completed as soon as conditions permit.
9. The excavated area shall be backfilled and the temporary pavement shall be completed on the same day trench is made. Open trenches shall not be permitted overnight.
10. If the edge of any excavation ends with two (2) feet or less to the curb or edge of the pavement, remove and replace all pavement between the edge of the trench and curb or edge of pavement at no additional cost other than at the unit price bid for pavement replacement.
11. All excavations shall be completely backfilled. Trenches may not be flushed or puddled except by specific permission of the City.
12. All backfill of trench work or excavated areas within City Road Right of Way shall be done in the presence of the assigned Inspector. If Inspector is not present and the excavated area has been backfilled, re-excavate the opening and backfill with the inspector present at Contractor's sole expense.
13. All openings shall be properly guarded, day and night, with approved signs, barricades, lights, etc. Flagmen shall be provided in the amount as directed by the involved jurisdiction's Police Department. If necessary, a uniformed police officer for traffic control will be determined by the involved jurisdiction's Police Department. Transverse openings shall be restricted so that not more than one half of a traveled way will be obstructed at any time, one line in each direction must be maintained at all times. Recessed and pinned steel plates are to be used as protection on openings maintained overnight in the traveled ways.
14. All pavement replacement, curbing, and sidewalk replacement shall be performed in strict accordance with the requirements of the City.
15. Materials for pavement shall be mixed, delivered, placed, and compacted in accordance with the RIDOT standards and as specified herein.
16. When the air temperature falls below 50 degrees F, extra precautions shall be taken in drying the aggregates, controlling the temperatures of the materials, and placing and compacting the mixtures.
17. No mixtures shall be placed when the air temperature is below 40 degrees F, nor when the material on which the mixtures are to be placed contains frost or has a surface temperature not suitable to the Engineer. Before the Contractor leaves each site, all areas shall be restored to original conditions. If the existing traffic lines are removed or damaged during the day's construction, the Contractor is to restripe these lines as necessary and return them to their original condition. Following final completion, restore all traffic lines with long life epoxy resin.

B. Permits

1. The Contractor shall be solely responsible for obtaining and maintaining all road opening and street closure permits with the City as needed. Notify police jurisdiction of work.

2. The Contractor shall apply for road opening permits from the Providence Department of Public Works Engineering Division, the City of Cranston and the Rhode Island Department of Transportation (RIDOT) depending on the agency with jurisdiction for the roadway. All road opening permits must be submitted a minimum of 2-weeks prior to the start of work.
3. Road opening permits in Cranston require payment for the road opening permit as well as payment of an administrator and engineering fee which will be paid for under the replacement Bid Items 1A and 1B.
4. Road opening permits are valid for 30-days from the date of issuance.
5. Contractor shall be responsible for taking out and maintaining the minimum required Insurances, Bonds, statements, and providing any and all information requested by the Department of Public Works to obtain permits.
6. Schedule all inspections 72-hours prior to the commencement of work. If the anticipated date and duration of work change, notify the City Department of Public Works Traffic Engineering Division the prior business day. Failure to notify the Department of Public Works may result in the nullification of the permit. Contractor shall be responsible for providing any and all information requested by the City Department of Public Works.

C. Protection of Traffic

1. Employ Police Officers as required by the Road Opening Permit to maintain and control the flow of traffic and for the protection of motorists and pedestrians. Place and maintain such barricades, detour signs, flashing lights, etc. as are deemed necessary by the by the involved jurisdiction's Police Department. Traffic control shall be coordinated with Police and City.
2. Special attention shall be given for the protection of pedestrians, school children, and motorists.
3. Ingress and egress shall be maintained to the abutting properties at all times.
4. Daily notification of the area of operations shall be made to the Engineer, Police, Fire Department, City Engineer, Department of Public Works, or City Road Supervisor.
5. No vehicular traffic or loads shall be permitted on the newly completed pavement until adequate stability has been attained and the material has cooled sufficiently to prevent distortion or loss of fines. If the climatic or other conditions warrant it, the period of time before opening to traffic may be extended at the discretion of the Engineer.
6. All agencies must be notified in the event of a detour or road closure, these include but are not limited to Police, Fire, and other emergency departments.

3.02 ROLLING AND COMPACTION

- A. Compaction shall be started immediately after spreading. Rollers shall be types approved by the Engineer. Rolling shall be a continuous process, and all parts of the pavement shall receive uniform compaction.
- B. Sidewalk compaction and curbing shall be inspected by the assigned Inspector. Curbing shall be raised level to the top of sidewalk.
- C. All pavement thicknesses referred to herein are compacted thicknesses. The Contractor shall place sufficient mix to ensure that the specified thickness of pavement occurs wherever called for.
- D. After the paving mixture has been properly spread, initial compaction shall be obtained by the use of power rollers weighing not less than 240 pounds per inch width of tread.

- E. Final compaction of the surface shall be accomplished by rollers weighing not less than 285 pounds per inch width of tread. Along curbs, structures and all places not accessible with a roller, the mixture shall be thoroughly compacted with tampers. Such tampers shall not weigh less than 25 pounds and shall have a tamping face of not more than 50 square inches. The surface of the mixture after compaction shall be smooth and true to the established line and grade.

3.03 TEMPORARY PAVEMENT

- A. Initial Pavement shall be placed immediately after trenches have been backfilled and compacted unless otherwise approved by the City. Initial Pavement shall be placed wherever existing pavement has been removed or disturbed as soon as practical, but in no case, more than 24 hours after backfilling is completed. Exceptions are noted elsewhere in the Specification.
- B. During the interval between the completion of backfill and the time of placement of initial paving, all areas shall be maintained in a safe and satisfactory condition to allow for normal traffic use.
- C. If working in Cranston during the winter months and the specified initial pavement is not available, the Contractor may substitute Type "A" cold patch material if approved in writing by the City. Cold patches shall be a minimum of 2" compacted, underlaid by the appropriate Base Course or Compacted backfill as applicable to the work area. However, as soon as Initial Pavement is available and a maximum of 7 days, the Contractor shall excavate the cold patch and base material to its full depth or a depth of 10-inches, whichever is greater, and replace it with compacted Initial Pavement. Installation and removal of temporary cold patch material and replacement with the specified Initial Pavement material shall be at no additional cost to the Initial Paving unit price bid.
- D. Cold patch is not allowed in the City of Providence at any time of year for roadways or sidewalks.
- E. The Initial Pavement shall be placed in two equal layers. Tack coat shall be applied between all layers and along the edges of the existing pavement. Prior to placing any initial, temporary pavement, ensure the edges of the cut pavement are vertical and square. The Engineer will inspect the conditions prior to pavement placement, and the Contractor will correct any deficiencies prior to paving operations. This Initial Pavement shall be maintained in a safe and usable condition and brought to pre-construction grade at no additional cost until top mix pavement is placed.
- F. The base pavement shall be placed and compacted by a roller to thoroughly compact the bituminous concrete without damaging the existing pavement. The width of the roller must be less than the width of the trench. The new pavement shall be rolled smooth and flush with the existing pavement.
- G. Hose clean all road surfaces adjacent to the trench area to be paved. No paving is to be placed until subsurface is dry.
- H. Initial pavement shall be maintained in a condition suitable for traffic until replaced or overlaid by top mix. Defects shall be repaired within 3 days of notification of such defects.

- I. If the Contractor fails to maintain the trench and pavements in a safe and satisfactory condition and fails to remedy these conditions, the Owner may repair these areas at his own expenses with the cost of such repairs being deducted from payments due to the Contractor.
- J. The work area shall be cleaned with a sweeper with a water attachment for dust control immediately after each excavation is backfilled and temporarily paved. A mechanical sweeper is required to be available on-site and used at all times while construction is taking place.

3.04 FINAL PAVEMENT

- A. Final pavement shall be completed on roads shown in Appendix C.

3.05 CONCRETE ROADS

- A. Where concrete road repair is required, concrete shall be placed to match existing concrete thickness. Steel plates shall be used to protect the concrete during curing time.
- B. Prior to placing concrete, the Contractor shall cut back the existing concrete for a minimum of twelve inches beyond the limits of the pipe trench. Existing concrete shall be of suitable quality to abut repair.
- C. Drill holes into the face of the existing concrete pavement not more than 1/4 inch in diameter greater than the dowels. Maintain vertical and horizontal alignment during drilling and do not damage existing concrete surrounding the hole. Before installing dowels and joint ties, clean the holes of cement dust, standing water, and materials that interfere with the proper bonding of the epoxy grout.
- D. Place concrete in 2 layers with the first layer placed to such a depth that the surface of the layer is at the proper elevation to receive the reinforcement steel. Place the reinforcement steel followed by the next layer of concrete. Remove and replace the lower layer concrete if it has developed initial set or has been in place more than 30 minutes before being covered with the next layer. Texture the surface using a stiff broom.
- E. Steel plates shall be set flush with surrounding pavement and pinned with a minimum of one spike at each corner of the individual steel plate.
- F. All manhole/catch basin covers, grates, valve covers, and other items at the roadway surfaces shall be appropriately raised or lowered to bring them flush with the new pavement.
- G. Repair any defects in curbing caused by the Contractor's operations.

3.04 STAMPED ASPHALT

- A. Repair stamped asphalt to match the pattern, color and texture of the surrounding stamped asphalt during the placement of the final surface course.

3.06 CONCRETE SIDEWALKS

- A. The subgrade shall be constructed to the required elevation to match the existing. All soft and unsuitable materials shall be removed and replaced with approved materials. The subgrade shall be compacted until a smooth, hard and dense surface is obtained. The subgrade shall be moistened prior to the placing of concrete.

- B. Forms shall be of wood or metal and shall be of the full depth of the concrete.
- C. Concrete shall be placed in the forms by methods which will prevent segregation, spread to the full depth and brought to grade by screening and straight edging and shall be floated with a wooden float to produce a surface free from irregularities.
- D. Joints shall be constructed in intervals of 12 ft, except for closures, but a slab shall not be less than 6 ft in length. Slabs shall be separated by transverse premolded expansion joint filler for the full width of the slab, extending from the bottom of the slab to within 1/4-in of its top surface. The slab between expansion joints shall be divided into blocks approximately 5 ft in length by scoring transversely. Transverse scoring shall extend to at least 1/3 of the depth of the concrete slab.
- E. Concrete sidewalk panels disturbed by construction activities shall be replaced in their entirety to the nearest joint. New slabs shall be separated from existing adjacent slabs by a transverse premolded expansion joint filler for the full width of the slab, extending from the bottom of the slab to within 1/4-in of its top surface.
- F. Where sidewalks are constructed adjacent to permanent structures or other rigid construction on one side and curb on the other, an expansion joint of premolded material extending along both structure and the curb shall be placed for the full depth of the slab. A premolded expansion joint shall be placed between the sidewalk and adjacent curb at all crosswalks. All joint filler shall be fastened to prevent displacement. The walk shall be sloped so that water will drain away from the structure.
- G. After the sidewalk has been placed and finished it shall be cured as specified in Section 03301.

3.07 CURBS

- A. Concrete curbs shall be constructed of the same dimensions as the existing curbs. Curbs shall be poured in forms and finished with a steel trowel, float or broom so as to duplicate the finish of the existing curb.

3.08 DRIVEWAY APRONS

- A. Driveway aprons shall be 6-inches thick and include 6" x 6" steel welded fabric placed in the center of the slab. The apron shall slope uniformly from sidewalk to gutter, without depressions or humps. The surface shall be broomed to create a rough but uniform surface. If existing apron is left in place, then the new apron shall be finished to match.

3.09 STRIPING

- A. Surface Preparation: All dirt, oil, grease and other foreign material shall be removed from the areas upon which the traffic paint or stripes are to be placed. Large areas of tar, grease or foreign materials may require sand blasting, steam cleaning or power brooming to accomplish complete removal. Application of stripes shall not proceed until final authorization is received from the Engineer.
- B. The paint shall be applied in accordance with the Rhode Island Department of Transportation Standard Specifications for Road and Bridge Construction. Traffic shall not be permitted until the paint is thoroughly dry.
- C. All disturbed pavement markings shall be replaced to the satisfaction of the Engineer.

- D. No thinners shall be used for the above listed pavement marking applications except in accordance with the manufacturer's specifications and at the direction of the Engineer.
- E. No paint or pavement marking material shall be heated above the temperature marked on the container.
- F. Bituminous concrete pavements shall have been in place for 48 hours prior to the application of pavement markings.
- G. If for any reason material is spilled or tracked on the pavement, or any markings applied, in the Engineer's judgement, fail to conform because of a deviation from the desired pattern, remove such material by a method that is not injurious to the roadway surface and is acceptable to the Engineer, clean the roadway surface and prepare the surface for a reapplication of markings and reapply the markings as directed without additional compensation for any of the foregoing corrective operations.
- H. Parking area pavement of each handicapped parking space shall be painted with an international symbol of accessibility as shown on the Drawings, and as approved by the Engineer. Provide an R7-8 sign in accordance with the Manual of Uniform Traffic Control Devices at each space. Sign shall be fastened to a single aluminum post and bottom of sign shall be mounted 5'-0" above finished grade. Post shall have a 12-in diameter by 4'-0" deep concrete base. Concrete shall conform to Section 03301.
- I. Access aisles shall be painted with parallel pavement markings as shown on the Drawings. Markings inside the perimeter border shall be equally spaced twice the distance of the line width.

END OF SECTION

SECTION 02577
INFRA-RED PAVEMENT REPAIR AND PATCHING

PART 1 GENERAL

1.01 SCOPE OF WORK

- A. When required by the road opening permit, furnish all labor, material, equipment, and incidentals required and replace all pavement removed over trenches or otherwise disturbed by the Contractor's operations utilizing infra-red paving techniques.
- B. Products, procedures, and equipment to provide a seamless repair of bituminous pavement by the application of evenly distributed infrared heat to aid in the reworking and remixing of the existing asphalt mix.
- C. New pavement installed by infra-red repair and patching method shall consist of bituminous concrete pavement placed over trenches as outlined below -
 - 1. Initial pavement shall be as per Section 02576 unless directed otherwise by the Engineer.
 - 2. Permanent pavement shall consist of initial pavement treatment by the infra-red method as specified below.
- D. Work consists of furnishing the labor, materials and equipment required to blend new bituminous material with infrared heated existing material to form a joint free integral mix. This special provision is for locations as indicated on the design plans or as directed by the Engineer.
 - 1. New pavement in streets shall consist of Class 9.5 (Marshall Mix: Class I, Type I-1) bituminous concrete pavement placed over trenches as outlined below.
 - 2. For non-state-owned roads, at a minimum, the restored pavement thickness shall match the existing depth of the roadway, or equal four (4) inches, whichever is greater, unless directed otherwise by the Owner. For state-owned roads, at a minimum, the restored pavement thickness shall match the existing depth of the roadway, or equal six (6) inches, whichever is greater.
 - 3. After a 60-day settlement period, permanent pavement shall consist of infra-red treatment of the initial pavement as specified herein.
 - 4. Driveway, parking area or sidewalk pavements damaged or disturbed by the Contractor's operations shall be repaired, restored or replaced in accordance with the requirements specified herein or as directed by the Engineer for the respective type of pavement replacement and in a manner satisfactory to the Owner and the Engineer.

1.02 RELATED WORK

- A. Trenching, backfilling and compaction are included in Section 02221.
- B. Granular fill materials are included in Section 02230.
- C. Pavement Repair and Resurfacing is included in Section 02576.

1.03 STANDARD REFERENCES

- A. Except as otherwise specified herein, the current Standard Specifications for Road and Bridge Construction, including all addenda, issued by the State of Rhode Island Department of Transportation (RIDOT), shall apply to materials and workmanship required for the work of this Section.
- B. American Association of State Highways and Transportation Officials (AASHTO)
 - 1. AASHTO M144 Standard Specification for Calcium Chloride.
- C. Where reference is made to one of the above standards, the revision in effect at the time of bid opening shall apply.

1.04 MAINTENANCE

- A. The Contractor shall warrantee the infrared patches for a 5-year period starting from the date of acceptance. Within the 5-year period, the Contractor will be held responsible for maintaining the final restoration work and repair any failures at no expense to the Owner. During this period, all areas that have settled or are unsatisfactory for traffic shall be refilled and replaced within 5 days of notification by the Owner.
- B. All material and labor required for such maintenance shall be supplied by the Contractor, and the work shall be done in a manner satisfactory to the Owner at no additional cost to the Owner.

1.05 QUALITY ASSURANCE

Failure to meet the warranty requirements constitutes a breach of contract. Failure is defined as the following:

- 1. Greater than 5% cracking in the repaired area within 12 months
 - 2. Greater than 5% raveling of material from the repaired area within 12 months
 - 3. Rutting more than ½” within 12 months
 - 4. Not providing a seamless repair
- A. The infra-red bituminous concrete pavement replacement and repairs shall be performed by a fully qualified, experienced paving subcontractor. Submit the following information for the proposed paving subcontractor to the Engineer for review and approval before any infra-red repair work is performed:
 - 1. The number of years of experience in performing specialized work of this nature.
 - 2. A list of municipal clients that the Contractor has performed this type of work for without any pavement deterioration resulting from heat treatment for a period of 5 years after repair.
 - 3. The list shall contain names and telephone numbers of persons who can be called to verify previous satisfactory performance.
 - 4. Work performed for utility companies will not be acceptable.

5. The size, number, type and BTU rating of the operational infra-red heating equipment and heated storage units owned that would be available for this project.
 6. The Contractor shall be capable of providing a variety of infra-red units having different shield sizes in order not to needlessly oxidize pavement beyond the limits of the repair.
- B. The Contractor shall also be capable of providing multiple crews as needed to complete the work without undue delay.
- C. The Owner reserves the right to approve or disapprove the Infra-red Contractor, based on the submitted qualifications and a follow-up interview.

PART 2 PRODUCTS

2.01 MATERIALS

- A. Bituminous concrete pavement and bituminous materials shall conform to Part 400 of the RIDOT Standard Specifications for Road and Bridge Construction.
- B. Hot Mix Asphalt Pavement (HMA) uniformly mixed and well graded. The Contractor shall maintain records to be given to the Owner upon request of the plant that supplied the HMA and of the gradation and Superpave binder grade (in accordance with RIDOT Standard Specifications) that is utilized in the Infrared Pavement Repair process.
1. Aggregate size for Wearing Course as prescribed by RIDOT shall conform to Class 9.5 (Marshall Mix: Class I, Type I-1) 9.5 mm maximum, well-graded aggregate.
 2. From pick up through placement, the Contractor shall conduct and record periodic temperature checks of the Virgin HMA in its hotbox to ensure the temperature does not fall below 250°F or exceed 300°F. This documentation shall be provided to the Owner upon request.
- C. Asphalt Rejuvenator Agent (ARA) shall be a petroleum product additive that falls under one of the recycling agent (RA) groups outlined in ASTM D4552.
1. The Contractor shall apply a one-component emulsified maltenes recycling agent (rejuvenator) in a ratio of 1:1 with water.
 2. The rejuvenator application area shall include both the area under repair as well as the area heated but left undisturbed around the perimeter of the repair.
 3. The application shall take place after the area has been scarified and just prior to the addition of new asphalt. The rejuvenator replaces the light oil component of asphalt which has oxidized out over time.
- D. Tack Coat/ Sealant shall be emulsified asphalt with the same asphaltic cement as the HMA pavement mix placed, SSI or equal. In accordance with requirements of AASHTO M140/M208 and Section 403 of RIDOT Standard Specifications.
- E. Cationic asphalt emulsion shall be a homogeneous asphalt emulsion and shall remain homogeneous for a minimum of three months. It shall conform to the requirements of AASHTO

M208 and except that its viscosity, Saybolt Furol at 77 degrees F, sec. shall be between 15 and 20.

- F. Stone dust for the cover material shall be free from dirt, organic material, clay balls and film, dust or other objectionable matter, and shall be suitable for the intended use as approved by the Engineer.
- G. Temporary pavement marking paint shall be epoxy and thermoplastic markings conforming to Section T.20 of the RIDOT Standard Specifications for Road and Bridge Construction. Paint shall be white or yellow to match existing conditions or as directed by the Engineer.
- H. Permanent pavement marking paint shall be epoxy resin reflectorized traffic paint conforming to Section T.20 of the RIDOT Standard Specifications for Road and Bridge Construction. Paint shall be white or yellow to match existing conditions or as directed by the Engineer.

2.02 EQUIPMENT

- A. PRV and Hotbox: Pavement Restoration Vehicle (PRV) shall be a truck mounted, self-contained pavement maintenance heating system (Hotbox) equipped with a fuel system and a heated chamber capable of maintaining the fresh asphalt at a temperature of 250-300°F. The Hotbox storage unit shall be utilized to ensure that sufficient hot virgin asphalt is on hand. This unit must ensure that the temperature of the asphalt is never in excess of 325 degrees Fahrenheit.
- B. Infrared Heater: The adjustable height infrared heating unit may be truck or trailer mounted to the PRV. The unit shall be equipped with a chamber or chambers capable of heating the existing bituminous pavement to a workable condition without oxidation or burning. There shall be no flame in direct contact with the existing bituminous surface.
 - 1. The heating chamber used shall consume no more than 12,500 BTU per square foot of heated area. This rate of consumption shall translate into the ability of the heater to soften asphalt to a depth of 1½ -2½ inches in 8-10 minutes without burning the surface.
- C. Commercial Grade Sprayer: The sprayer for the asphalt rejuvenator agent (ARA) shall deliver the ARA with a fan spray ensuring equal and uniform coverage of the heated. The sprayer shall have a clear tank with measurement markings on the side or a fluid gauge to determine the amount of ARA used.
- D. Steel Rake: A steel rake shall be used to delineate the repair area along the chalk line and to scarify the heated area of the patch inside the chalk line to a depth of at least 2 inches.
- E. Asphalt Lute: A 36-inch-wide lute shall be used to evenly distribute the added asphalt and to establish the proper grade.
- F. Tandem Ride-on Vibratory Roller: Compaction shall be achieved with a tandem ride-on 1.25 Ton (min) Vibratory Roller.

PART 3 EXECUTION

3.01 GENERAL

- A. Materials for pavement shall be mixed, delivered, placed and compacted in accordance with the RIDOT standards and as specified herein.
- B. Whenever the sub-base becomes dry enough to cause dust problems, spread water uniformly over the gravel surface in sufficient quantity to eliminate the dust.
- C. When the air temperature falls below 50 degrees F, extra precautions shall be taken in drying the aggregates, controlling the temperatures of the materials, placing and compacting the mixtures.
- D. No mixtures shall be placed when the air temperature is below 40 degrees F unless authorized in writing by the Engineer.
- E. No mixtures shall be placed when the material on which the mixtures are to be placed contains frost or has a surface temperature not suitable to the Engineer.
- F. Identify, mark, and measure the specific area to be repaired in coordination with the Owner's representative (Inspector).
 - 1. A chalk line shall be drawn a minimum of 6" beyond the original temporary patch limits, unless otherwise directed by Owner.
- G. No vehicular traffic or loads shall be permitted on the newly completed pavement until adequate stability has been attained and the material has cooled sufficiently to prevent distortions or loss of fines. If the climatic or other conditions warrant it, the period of time before opening to traffic may be extended at the discretion of the Engineer.

3.02 INSTALLATION

- A. Heat area to be repaired to a sufficient temperature using infrared heat to allow remixing of the asphalt without oxidation or burning.
 - 1. The heater shall be lowered to within 10-14 inches of the existing pavement, centered over the existing temporary patch with at least 6" of heated area beyond the perimeter of the original opening (as delineated with the chalk outline).
 - 2. Do not exceed a surface temperature of 350° F. Measurement shall be conducted with a temperature probe or infrared temperature gun provided by the contractor. If the temperature is exceeded additional material shall be removed.
 - 3. Heating is sufficient when the existing asphalt can be worked with a rake to a depth of 2 inches (typically 8-10 minutes).
- B. After heating no less than the top ¼ - ½" of asphalt shall be removed to take away any charred material. If the surface temperature exceeds 350°F as mentioned in section 3.3.A.2, another ½" of material shall be removed for every 100°F over.

- C. ARA shall be uniformly sprayed to the surface of the heated asphalt with a fan nozzle at a rate of 0.1-0.5 gallons per square yard. The color of the ARA will be used to help assess adequate coverage.
- D. Using a hand rake or mechanical tiller, scarify and thoroughly mix the repair area to depth of 2 inches. Add additional virgin HMA as necessary. As required, the Contractor shall add the Superpave Class 9.5 (Marshall Mix Class 1 Type I-1) surface coarse asphalt mix.
 - 1. When placing additional HMA the temperature shall not fall below 225 degrees F during placement.
- E. Reshape repair area by hand (luting) to match grade of adjacent pavement.
- F. Compact the surface with a tandem 1.25 ton (min) ride-on vibratory roller. The surface should be smooth, tight, and matching the grade of the adjacent pavement.
 - 1. The outside perimeter shall be compacted first in order to ensure a full thermal bond with the existing heated pavement.
 - 2. If greater than 2 inches of asphalt is to be compacted, multiple lifts should be placed and compacted.
 - 3. If evidence of asphalt shoving occurs during compaction the vibratory compactor shall be operated in static mode or the pavement shall be allowed to cool for a slight amount of time before compaction resumes.
 - 4. The temperature of the asphalt shall not fall below 175 degrees F during compaction. Temperature at compaction shall be recorded by the Contractor.
- G. At the direction of Owner, stone dust or fine sand may be applied to reduce the tackiness of the patch. Sand should be evenly distributed over the surface to fill small voids and absorb excess sealant if surface sealant is applied.
- H. The total time for a typical single heat restoration should be no more than 20-25 minutes. This timeframe shall be strictly adhered to ensure that both the heated pavement and added asphalt have not been allowed to cool significantly. This provides the proper fusion between the repair and the existing road surface.
- I. Allow the repaired area to cool to 175°F before opening to traffic. Measurement shall be conducted with an infrared temperature gun.
- J. No vehicular traffic or loads shall be permitted on the newly completed pavement until adequate stability has been attained and the material has cooled sufficiently to prevent distortions or loss of fines. If the climatic or other conditions warrant it, the period of time before opening to traffic may be extended at the discretion of Owner.

3.03 PAVEMENT MARKINGS

- A. Reline all streets with pavement markings equal in materials, type, and location to those that existed prior to excavation.

END OF SECTION

SECTION 02616
DUCTILE IRON PIPE AND FITTINGS

PART 1 GENERAL

1.01 SCOPE OF WORK

- A. Furnish all labor, materials, equipment, and incidentals required, install, disinfect, test and repair ductile iron pipe and fittings as may be directed by the Engineer.
- B. Where the word “pipe” is used it shall refer to pipe, fittings, or appurtenances unless otherwise noted.
- C. Existing asbestos water main shall be removed and replaced with a ductile iron pipe of equal size. This work shall be paid for under the allowance, Miscellaneous Work at Direction of the Owner.
- D. All water main work shall be in accordance with this Section regardless of whether it is work requested by the Owner and paid for under the allowance Miscellaneous Work at Direction of the Owner or results from the Contractor’s activities where no additional compensation will be provided by the Owner.

1.02 RELATED WORK

- A. Trenching, Backfilling, and Compaction are included in Section 02221.
- B. Granular Fill Materials are included in Section 02230.
- C. Water Service Connections are included in Section 02663.

1.03 SUBMITTALS

- A. Submit to the Engineer in accordance with Section 01300 shop drawings and product data for review.
- B. Submit a certified affidavit of compliance from the manufacturer stating that the pipe, fittings, gaskets, linings, and exterior coatings for this project have been manufactured and tested in accordance the ASTM and AWWA standards and requirements specified herein.
- C. This project is funded in part by the Rhode Island Infrastructure Bank via the Drinking Water State Revolving Fund (DWSRF). As part of that program, iron and steel materials and equipment shall meet the American Iron and Steel requirements Provide a certificate of compliance with the shop drawings for items in this section.

1.04 QUALITY ASSURANCE

- A. All ductile-iron pipe and fittings shall be from a single manufacturer on the List of Approved Materials/Manufacturers in Appendix F. Each length of ductile-iron pipe supplied for the project shall be hydrostatically tested at the point of manufacture to 500 psi for a duration of 10 seconds per AWWA C151. Testing may be performed prior to machining bell and spigot. Failure of ductile-iron pipe shall be defined as any rupture of the pipe wall.
- B. All ductile-iron pipe and fittings to be installed under this project shall be inspected and tested at the foundry as required by the standard specifications to which the material is manufactured.

- C. Inspection of the pipe and fittings will be made by the Engineer or representative of the Owner after delivery. The pipe shall be subject to rejection at any time on account of failure to meet any of the requirements specified herein, even though pipes may have been accepted as satisfactory at the place of manufacture. Pipe rejected after delivery shall be marked for identification and immediately removed from the job site.
- D. All pipe and fittings shall be permanently marked with the following information:
 - 1. Manufacturer, date.
 - 2. Size, type, class, or wall thickness.
 - 3. Standard produced to (ASTM, AWWA, etc).
 - 4. Interior coating type.

1.05 DELIVERY, STORAGE, AND HANDLING

- A. Care shall be taken in loading, transporting, and unloading to prevent injury to the pipe. Under no circumstances shall the pipe be dropped or skidded against each other. Slings, hooks, or pipe tongs shall be used in pipe handling.
- B. Materials, as stored, shall be kept safe from damage. The interior of all pipe, fittings, and other appurtenances shall be kept free from dirt or foreign matter at all times.
- C. Pipe shall not be stacked higher than the limits recommended by its manufacturer. The bottom tier shall be kept off the ground on timbers, rails, or concrete. Stacking shall conform to the manufacturer's recommendations.
- D. Gaskets for mechanical and push-on joints to be stored shall be placed in a cool location out of direct sunlight. Gaskets shall not come in contact with petroleum products. Gaskets shall be used on a first-in, first-out basis.

PART 2 PRODUCTS

2.01 PIPING

- A. Zinc coated ductile iron pipe shall be from manufacturers listed in Appendix F and must conform to AWWA C151. Pipe shall be supplied in standard lengths as much as possible.
- B. Thickness design shall be per AWWA C150, except provide minimum Thickness Class 52 piping. In areas of the system where "High Service Fire Mains" are present or other circumstances directed by the Owner, Class 56 ductile iron pipe shall be required.
- C. Metalized detectable identification tape, 2-inches wide, blue in color and imprinted with the words "Caution - WATER LINE BURIED BELOW," shall be utilized over the new water main and all service lines from the main to curb stop. The tape shall be buried a depth of 18-24 inches below finished grade.

2.02 JOINTS

- A. Mechanical Joints with Retainer glands shall be used for Ductile Iron Fittings underground.

2.03 FITTINGS

- A. The zinc coated ductile iron fittings shall be from manufacturers listed in Appendix F. Fittings are to be furnished and installed by the Contractor under these specifications and shall be Rubber Seat Mechanical Joints. The fittings shall be standard length or short body castings conforming to AWWA Standard Ductile Iron Fittings specifications designation C-153 or ANSI Standard for Ductile Iron Fittings specifications designation A21.53, newest edition and as amended to date. Fittings shall be Class 350 and 250.
- B. Cement mortar lining shall be in accordance with AWWA C-104 or ANSI A21.4, newest edition and as amended to date.
- C. Zinc Coating - The exterior of ductile iron fittings shall be coated with a layer of arc-sprayed zinc per ISO 8179, newest edition and as amended to date. The external protective coating system shall be factory applied to ductile iron pipeline components as specified in ISO 2531. A finishing layer topcoat shall be applied to the zinc. The coating system shall conform in every respect to ISO 8179, newest edition and as amended to date.
- D. Rubber gaskets for pipes and fittings shall be in accordance with AWWA specification designation C-111 or ANSI A21.11, newest edition and as amended to date.

2.04 INTERIOR LINING

- A. Ductile iron pipe and fittings shall have a double thickness cement mortar lining in accordance with AWWA C104 and liner shall be NSF/ANSI 61 certified. Ductile iron pipe and fittings shall have the same type of lining.

2.05 EXTERIOR COATING

- A. Zinc Coating - The exterior of ductile iron pipe shall be coated with a layer of arc-sprayed zinc per ISO 8179, newest edition and as amended to date. The external protective coating system shall be factory applied to ductile iron pipeline components as specified in ISO 2531. A finishing layer topcoat shall be applied to the zinc. The coating system shall conform in every respect to ISO 8179, newest edition and as amended to date.

2.06 REPAIR SLEEVES

- A. Repair sleeves for repairing potable water mains shall be from a single manufacturer on the List of Approved Materials/Manufacturers in Appendix F. Clamps for water mains up to and including 10-inches in diameter shall be single band and clamps for water mains greater than 10 inches in diameter shall be multi-band. All clamps shall be Type 304 stainless steel, with Type 304 stainless steel bolts and nuts. Clamp width shall be as required to properly and fully seal the leak area.
- B. Mechanical Joint solid sleeves shall be from a single manufacturer on the List of Approved Materials/Manufacturers in Appendix F. Solid sleeves shall be installed with ductile iron retainer glands and shall be installed in accordance with manufacturers recommendations. Solid sleeves shall be installed where shown on the drawings and where necessary to prevent movement of cut out lengthen that are to be rejoined.
- C. Flexible couplings shall be from a single manufacturer on the List of Approved Materials/Manufacturers in Appendix F. Couplings shall be used only where existing pipe diameters make the use of mechanical joint solid sleeves inappropriate. Couplings shall be

installed in accordance with the recommendations of the manufacturer. All flexible couplings are to be adequately harnessed to withstand the test pressures in the lines unless other means are provided to take the thrust. Where new ductile iron mains are to be joined to existing pit cast pipe, transitional couplings suitable for the actual field-measured pipe diameters shall be provided.

- D. Coupling devices for connecting existing water mains to new mains shall be from a single manufacturer on the List of Approved Materials/Manufacturers in Appendix F. All couplings shall be furnished with a fusion bonded epoxy coating meeting the requirements of AWWA C213 and AWWA C550.

PART 3 EXECUTION

3.01 GENERAL

- A. Care shall be taken in loading, transporting and unloading to prevent injury to the pipe, lining or coatings. Pipe or fittings shall not be dropped. All pipe or fittings shall be examined before laying, and no piece shall be installed which is found to be defective. Damage to the pipe linings or coatings shall be repaired per manufacturer's recommendations. Handling and laying of pipe and fittings shall be in accordance with the manufacturer's instruction and as specified herein.
- B. Prior to delivery, all lengths of ductile iron must be secured with plastic bags on both ends.
- C. If any defective pipe is discovered after it has been laid, it shall be removed and replaced with a sound pipe in a satisfactory manner. All pipe and fittings shall be thoroughly cleaned before laying, shall be kept clean until they are used in the work, and when installed or laid, shall conform to the lines and grades required.

3.02 INSTALLING DUCTILE IRON PIPE AND FITTINGS

- A. Ductile iron pipe and fittings shall be installed in accordance with requirements of AWWA C600, except as otherwise specified herein. A firm, even bearing throughout the length of the pipe shall be provided by digging bell holes at each joint and by tamping backfill materials at the side of the pipe to the springline. Blocking will not be permitted.
- B. All pipe and fittings shall be sound and clean before laying. When laying is not in progress, including lunchtime, the open ends of the pipe shall be closed by watertight plugs or other approved means. Sufficient backfill shall be placed to prevent flotation. Good alignment shall be preserved in laying. The deflection at joints shall not exceed 75 percent of allowable deflection recommended by the manufacturer. If any defective pipe or fitting is discovered after it has been laid, it shall be removed and replaced with a sound pipe in a satisfactory manner at the Contractor's own expense.
- C. All ductile iron pipe laid underground shall have a minimum of 4.5-ft of cover.
- D. Fittings, in addition to those shown on the Drawings, shall be provided, where required, in crossing utilities that may be encountered upon opening the trench. Solid sleeve closures shall be installed at locations approved by the Engineer.
- E. The pipe interior shall be maintained dry and brush clean throughout the construction period.
- F. When cutting pipe is required, the cutting shall be done by machine, leaving a smooth cut at right angles to the axis of the pipe. Cut ends of pipe to be joined with a bell shall be beveled to

conform to the manufactured spigot end. Cement lining shall be undamaged. Field cut ends shall be sealed with approved epoxy in accordance with manufacturer's instructions. Cutting of restrained joint pipe will not be allowed, unless approved at specific joints in conjunction with the use of mechanical joint retaining brands or field adaptable restrained joints.

G. Concrete thrust blocks shall be installed at all fittings and other locations as directed by the Engineer. Joints shall be protected by felt roofing paper prior to placing concrete. Concrete shall be placed against the undisturbed material, and shall not cover joints, bolts or nuts, or interfere with the removal of any joint. Wooden side forms or sandbags shall be provided for thrust blocks.

H. Jointing Ductile-Iron Pipe

1. Mechanical joints shall be assembled in strict accordance with the manufacturer's instructions and AWWA C600. Pipe shall be laid with bell ends looking ahead. To assemble the joints in the field, thoroughly clean and lubricate the joint surfaces and rubber gasket. Bolts shall be tightened to the specified torque. Under no condition shall extension wrenches or pipe over the handle of ordinary ratchet wrench be used to secure greater leverage.
2. Bolts in mechanical or restrained joints shall be tightened alternately and evenly.
3. Restrained joints shall be installed according to the pipe manufacturer's instructions.
4. Transition couplings shall be used where new ductile iron mains are to be joined to existing pit cast pipe and be from a single manufacturer on the List of Approved Materials/Manufacturers in Appendix F. Couplings shall be installed in accordance with the recommendation of the manufacturer. All transition couplings are to be adequately harnessed to withstand the test pressures in the lines unless other means are provided to take the thrust.

3.03 TESTING

- A. After installation, the pipe shall be tested for compliance as specified herein. Furnish all necessary equipment and labor for the pressure tests and leakage tests on the pipelines. The Engineer shall approve the procedures and method for carrying out the pressure and leakage tests.
- B. Submit detailed test procedures and method for Engineer's review. In general, testing shall be conducted in accordance with Section 4 of AWWA C600.
- C. Pressure pipelines shall be subjected to a hydrostatic pressure 50 percent above the normal operating pressure for the line being tested. This test pressure shall be maintained for a minimum of 2 hours. The leakage rate shall not exceed those indicated in AWWA C600. Provide suitably restrained bulkheads as required to complete the hydrostatic testing specified.
- D. All valves and valve boxes shall be properly located, installed, and operable prior to testing. Bulkheads shall be provided with a sufficient number of outlets for filling and draining the line and for venting air.
- E. Duration of pressure test shall not be less than 2 hours. The leakage test shall be a separate test following the pressure test and shall not be less than 2 hours in duration. All leaks evident at the surface shall be repaired, and leakage eliminated regardless of the total leakage as shown by the test. Lines that fail to meet test criteria shall be repaired and retested as necessary until test requirements are met. Defective materials, pipes, valves, and accessories shall be removed and replaced.

3.04 CLEANING

- A. At the conclusion of the work, thoroughly clean the entire pipe by flushing with water or other means to remove all dirt, stones, pieces of wood, or other material that may have entered during the construction period. All debris shall be removed from the pipeline. The lowest segment outlet shall be flushed last to assure debris removal.

3.05 DISINFECTION

- A. Ductile iron pipe used for potable water service shall be disinfected after cleaning. Provide all necessary equipment and labor for the disinfection.
- B. Disinfection shall be in accordance with AWWA C651 standard.
- C. Discharge of chlorinated water shall comply with all Federal, State, and local standards. Provide sodium bisulfite for dechlorination prior to discharge. Under no circumstances shall chlorinated water be discharged to the combined sewer and/or drain system without dechlorinating to a maximum 1-mg/l of residual chlorine and the express permission of the Engineer.
- D. Heavily chlorinated water must be disposed of in a manner that conforms to all local, State and Federal regulations. Disposal may be to the sanitary sewer system or storm sewer system. The proposed disposal site shall be approved by the Engineer.
 - 1. If the Contractor elects to direct the heavily chlorinated water to the sanitary sewer system, the Contractor shall contact the local sewer department to ascertain any requirements for discharge. Any fees associated with the discharge to the sanitary sewer system shall be included in the unit price.
 - 2. If the Contractor elects to direct the heavily chlorinated water to a storm sewer system, the chlorine residual of water being disposed of shall be neutralized by treating with one of the reducing agents listed in Table 1. The amount of reducing agent applied shall be sufficient to the lower chlorine residual of the water disposed to 0.0 mg/l. If the Contractor elects to utilize a chemical for dechlorination, the water shall be aerated prior to discharge to the storm sewer system.

Table 1. Pounds of Chemical Required to Neutralize Various Residual Chlorine Concentrations in 100,000 Gallons of Water.

Residual Chlorine Concentration (mg/l)	Sulfur Dioxide (SO ₂)	Sodium Bisulfite (NaHSO ₃)	Sodium Sulfite (NaSO ₃)	Sodium Thiosulfate (Na ₂ S ₂ O ₃ ·5H ₂ O)
1	0.8	1.2	1.4	1.2
2	1.7	2.5	2.9	2.4
10	8.3	12.5	14.6	12.0
50	41.7	62.6	73.0	60.0

- 3. Engage a State Certified potable water testing lab to perform all bacteriological testing; and pay all costs of the testing. The laboratory must be acceptable to the Owner.

END OF SECTION

SECTION 02663
WATER SERVICE CONNECTIONS

PART 1 GENERAL

1.01 SCOPE OF WORK

- A. Typical Water Service Connection Details are included in Appendix B of this Project Manual. Replace existing lead service lines using trenchless technology in accordance with these details.
- B. Obtain approval from the Engineer to install the entire new service line, or portions of the new service line, utilizing a method other than a trenchless method. If a service line or portion of the new service line, is installed via open-cut trench due to site conditions, failure of trenchless methods or other approved reasons, payment shall be under Bid Items 1A, 1B, 2A, 2B, 3A, or 3B, the same as if the service line was installed via trenchless methods including all restoration requirements as specified.
- C. Furnish all labor, materials, equipment, tools, and incidentals required to verify existing service line material, replace water service connections to the limits directed by the Engineer. Furnish all necessary labor and equipment to replace existing lead service line piping and install new rolled copper tubing, saddles on water mains as required, corporation stops, curb stops, curb boxes, meter pits as required, adapters and fittings of the necessary size required, and restore the street, sidewalk, landscaped areas and any other areas disturbed by construction to their original condition unless otherwise stated.
- D. Contractor shall make no replacement on the public side of the service line if the public side (corporation to curb stop) is copper or plastic. Contractor shall replace the private side of the service line if it is found to be lead, and provided that the Homeowner has signed the Right-of-Entry (ROE) and Release Form for Lead Service Line Replacement.
- E. The Contractor may encounter different water main pipe materials such as Asbestos Cement, Cast Iron or Ductile Iron. See typical details in Appendix B requirements to connect the new services to water mains.
- F. Unless otherwise directed, the new curb stops shall be located 1.5-feet behind the curb line. Contractor shall be responsible for the removal of existing curb stops and/or installation of curb stops in the locations directed by the Engineer.
- G. Unless otherwise directed, any service line with a diameter less than 1.0 inches in diameter shall be replaced with a 1.0-inch service line. Any existing service line with a diameter greater than 1.0 inches shall be replaced with a new service line of the same diameter as the existing pipe.
- H. A list of addresses for lead service lines to be replaced as part of this project are listed in Appendix A of this Project Manual. Owner may add or remove properties to this list. Contractor may add properties only under circumstances specified in Section 01170.
- I. Any lead service piping removed shall be handled and disposed of in accordance with all local, state and federal laws and regulations.
- J. Replacement work within private property shall be coordinated with the Owner, Engineer, Property Owner and Residents prior to starting any work.

- K. For service replacements into the building, Contractor shall either bring the new rolled copper tubing, by expanding the existing pipe penetration, into the building or create a new penetration for the new water service line, as approved by the Engineer. The water service line shall extend into the building and be reconnected to the existing water meter. Water meter orientation shall be horizontal. If any water meter is found to be oriented vertically, Contractor shall notify Owner immediately. If a meter is found to be broken or is missing, the Contractor shall notify the Owner immediately, in accordance with Section 15410, to obtain a new meter. If the meter is located in a pit, the meter is to be relocated and the pit filled with concrete in accordance with the details in Appendix B. The Contractor shall repair and provide a watertight seal of the pipe penetration through the building in accordance with Section 01180, as approved by Engineer.
- L. Existing water service lines constructed of pipe materials that contain lead or of a pipe material not designed for use in a potable water system shall be considered lead, replaced as such, and paid for under the appropriate associated Bid Item. These materials include but are not limited to brass, galvanized and black iron.
- M. If portions of the interior plumbing on the downstream side of the water meter are found to be lead, Contractor is to immediately contact the Engineer.
- N. Maintain an on-site supply of anticipated specialty fittings, including but not limited to tapping saddles, repair clamps, repair sleeves, repair saddles, corporation stops, curb stops, curb boxes, fittings to connect to meters of a different size than the pipe, etc., such that the work proceeds without impacting the execution of the work and causing a delay in connecting the service.
- O. Adjust alignment of the new service to avoid damaging existing trees and tree roots. Engineer may require an alternate alignment which will be anywhere along the frontage of the property.
- P. Any changes to meter alignment must be first approved by the Owner and must comply with Providence Water Supply Board Rules and Regulations Section 2.1.3.
- Q. If at any point the Contractor encounters a leaking service line at an adjacent property to a scheduled service line replacement or on a portion of the service line that is not lead, Contractor shall notify Owner immediately to determine the appropriate course of action.
- R. Dewatering shall be in accordance with Section 02140. Dewatering cost shall be included in applicable service line replacement Bid Items. If, during the course of work, an existing corporation stop becomes dislodged from the water main for any reason, Contractor shall immediately contact Owner to coordinate shut down of main and repair. Owner's inspector shall be present. The contractor shall be responsible for dewatering the excavation to perform a new water service connection in the dry, all work and dewatering shall be included in the applicable replacement Bid Item.

1.02 RELATED WORK

- A. Special Provisions are included in Section 01170.
- B. Pipe Penetration is included in Section 01180.
- C. Photographic Documentation is included in Section 01322.
- D. Project Record Documents are included in Section 01720.

- E. Trenching, Backfilling, and Compaction are included in Section 02221.
- F. Granular Fill Material is included in Section 02230.
- G. Interior Service Piping - 15410

1.03 SUBMITTALS

- A. Submit, in accordance with Section 01300, and within 10 days after signing the contract a list of materials to be furnished, the name of suppliers and the date of delivery of materials on the job site. Submit means and methods for repairing and sealing pipe penetrations through all types of building foundations during shop drawing submittals. All proposed means and methods for repairing and sealing pipe penetrations through building foundations shall be reviewed by the Engineer.
- B. This project is funded in part by the Rhode Island Infrastructure Bank via the Drinking Water State Revolving Fund (DWSRF). As part of that program, iron and steel materials and equipment shall meet the American Iron and Steel requirements. Provide a certificate of compliance with the shop drawings for items in this section.

1.04 REFERENCE STANDARDS

- A. National Sanitation Foundation (NSF)
 - 1. NSF 61 - Drinking Water System Components Health Effects.

1.05 DELIVERY, STORAGE AND HANDLING

- A. All materials shall be inspected for size, quality, and quantity against approved shop drawings upon delivery.
- B. Delivery schedule of all equipment shall be coordinated with the Contractor. Equipment ready for shipment prior to the agreed upon shipping date shall be stored without cost to the Owner by the manufacturer.
- C. All materials shall be suitably packed for shipment and long-term storage. Each package shall be labeled to indicate the project and the contents of each package. Where applicable, equipment numbers shall be marked on the container.
- D. All equipment shipped that is exposed, such as on a flatbed truck, shall be protected during transit. The equipment shall be protected from moisture, road salt, dirt, stones or other materials thrown up from other vehicles. Electrical components shall be protected as above, but with special attention to moisture. The method of shipment protection shall be defined in the submittals.
- E. All materials shall be stored in a covered dry location off of the ground. When required to protect the materials they shall be stored in a temperature-controlled location.

1.06 QUALITY ASSURANCE

- A. All products and materials provided for potable water service application shall be certified “lead-free,” by an ANSI certified, third-party independent organization. The term “lead-free” shall refer to the wetted surface of the pipe, fittings, and fixtures in potable water systems that have a weighted average lead content less than or equal to 0.25 percent per the Safe Drinking Water Act (Sec. 1417) amended in 2020 and other equivalent state regulations.
- B. All products of a given type included in this Section shall be furnished by or through a single manufacturer.
- C. Inspection by the Engineer's representative or failure to inspect shall not relieve the Contractor of responsibility to provide materials and perform the work in accordance with the Contract Documents.
- D. The piping manufacturer shall furnish an affidavit of compliance certifying that all materials used and work performed complies with the specified requirements. Provide copies of the mill test confirming the type of material used in the various components.
- E. All the types of valves and appurtenances shall be the product of well-established firms who are fully experienced, reputable and qualified in the manufacture of the equipment to be furnished. The equipment shall be designed, constructed and installed in accordance with the best practices and methods and shall comply with this Section as applicable.
- F. The Owner and Engineer reserve the right to sample and test any materials after delivery and to reject all components represented by a sample that fails to comply with the specified requirements.

1.07 WARRANTY:

- A. Warrant the work against defects for one (1) year from the date of Substantial Completion.

PART 2 PRODUCTS

2.01 COPPER SERVICE PIPE

- A. Service pipe shall be soft, annealed seamless rolled copper tubing conforming to ASTM B88 and NSF/ANSI 61 requirements, Type “K” with a maximum working pressure of 200 psi. The name and trademark of the manufacturer shall be stamped along the pipe. Copper tubing shall be a minimum of 1-inch or shall match the existing service connection size if larger than 1-inch. Type “L” copper tubing may be used for interior piping only in accordance with Section 15410.
- B. Tubing for water services over 100 ft. long shall be polyethylene CTS water service tubing (PE 3408) with a 200-psi pressure rating in accordance with AWWA Standard Specification C-901

2.02 FITTINGS

- A. Line fittings, as required on the new service line and if approved by Engineer, shall be standard three-part unions conforming to AWWA C800. For full-service line replacements from the water main into the building, fittings shall be used only at the corporation and curb stop.

- B. All service fittings shall be in accordance with Appendix F – List of Approved Materials/Manufacturers for Use in the Providence Water Distribution System. Contractors are responsible for contacting Owner to verify their selection of materials prior to starting any construction.
- C. The couplings shall be the "lead-free" brass compression style couplings for use with service piping (tubing), or the polypropylene compression couplings as specified herein. The conventional brass couplings shall be utilized for service connections when the house (building) foundation is less than ten (10) feet from the curb stop location. The polypropylene couplings shall be utilized for service connections when the foundation is greater than ten (10) feet from the curb stop location.

2.03 JOINING OF PIPE

- A. Pipe shall only be joined if approved by the Engineer.
- B. Compression
 - 1. Rolled copper tubing shall be joined by bronze bodied compression fittings with a synthetic rubber gasket that holds stainless steel gripper band, such as Mueller 110 Compression Connections or equal.

2.04 VALVES AND APPURTENANCES

- A. Valves and appurtenances shall be in accordance with Appendix F – List of Approved Materials/Manufacturers for Use in the Providence Water Distribution System. Contractors are responsible for contacting Owner to verify their selection of materials prior to starting any construction.
- B. All valves for service lines shall open right - clockwise. Valves of the same type shall be identical and from one manufacturer.
- C. Valves shall have the name of the maker, nominal size, flow directional arrows, working pressure for which they are designed and standard to which they are manufactured cast in raised letters on some appropriate part of the body.
- D. Unless otherwise noted, valves shall have a minimum working pressure of 200 psi and suitable for the pressures noted where they are installed.
- E. Valves shall be of the same nominal diameter as the pipe or fittings they are connected to. Except as otherwise noted, joints shall be compression joints for copper tubing.
- F. Valves shall be specially constructed for buried service.

2.05 CORPORATION STOP ASSEMBLIES

- A. Corporation stops shall be lead-free meeting all NSF lead-free requirements, shall be compliant with ASTM B62 and AWWA C800. Corporation stops for service connections shall not be less than 3/4-inch in diameter. Corporation stops shall be the same size as the service unless otherwise directed by the Engineer. Corporation stops shall be rated at 200 psi working pressure.

- B. Corporation Stops shall be from manufacturers in accordance with Appendix F – List of Approved Materials/Manufacturers for Use in the Providence Water Distribution System. Contractors are responsible for contacting Owner to verify their selection of materials prior to starting any construction.
- C. The inlet thread of all corporation stops shall be AWWA Standard CC inlet thread for their respective sizes. The outlet of all corporation stops shall be provided with compression couplings for type "K" copper service pipe for their respective sizes.
- D. New corporation stops shall be installed in the same location as the existing. The existing corporation stop shall be removed from the main using the tapping machine with the extraction tool and the new stop shall be installed after drilling for the larger corporation.

2.06 CURB STOP ASSEMBLIES

- A. Curb stops shall be from manufacturers in accordance with Appendix F – List of Approved Materials/Manufacturers for Use in the Providence Water Distribution System. Contractors are responsible for contacting Owner to verify their selection of materials prior to starting any construction.
- B. Curb stops shall be manufactured in accordance with AWWA Standard C800 and shall be "Lead-Free" as defined for lead-free brass alloys in accordance with the ANSI/NSF- 60 and ANSI/NSF-61 standards for components in contact with potable water. These products shall have the letters "NL" or "LF" cast into the main body of curb stop for proper identification.
- C. Curb stops shall be ball valve type with combined cap and tee and shall be provided with a positive stop at fully open and fully closed.
- D. The inlet and outlet ends of the curb stops shall be provided with compression couplings for Type "K" copper service pipe for their respective sizes.
- E. The curb stops to be furnished under these specifications shall "OPEN TO THE RIGHT - CLOCKWISE."

2.07 CURB BOXES

- A. Curb boxes shall be installed for all new curb stops. Curb boxes shall be compatible with approved curb stop.
- B. Curb boxes shall be from manufacturers in accordance with Appendix F – List of Approved Materials/Manufacturers for Use in the Providence Water Distribution System. Contractors are responsible for contacting Owner to verify their selection of materials prior to starting any construction. Lid shall be inscribed with "WATER". Box extension shall be 50.5-inches to 60-inches fully extended or shall be sized to fit actual service depth.
 - 1. Curb boxes for $\frac{3}{4}$ and 1" services shall be Erie style type boxes with an arch or bell bottom and shall be so constructed as to permit the total length of the box to be adjusted from not less than 4 $\frac{1}{2}$ feet to 5 $\frac{1}{2}$ feet.
 - 2. The upper section of the box shall not be less than one (1) inch in diameter and provided with a suitable and removable cover. The covers for all curb boxes shall be screwed to top section, have a bronze pentagon plug, and have the word "Water" cast into them.

3. The boxes shall be constructed so as to prevent the separation of the upper section from the lower section and to prevent the upper section from turning when removing the lid.
4. The boxes shall be furnished with stationary rods extending up into the upper section to allow the use of a short wrench. The rod shall be stainless steel not less than 5/8 of an inch in diameter, the upper end of which shall be shaped to receive a curb stop operating wrench. The lower end of the rod shall be provided with a malleable iron fork to fit standard curb stop operating keys. A suitable pin shall be furnished to attach the rod to the key.
5. The boxes shall be coated both inside and outside with the manufacturer's standard paint or enamel.
6. The service box covers are to be furnished with a plug cover.
7. Curb boxes for 1-1/2 inch and 2-inch curb stops shall be constructed of a cast iron two section roadway style box and shall have a 4-1/2 inch cover with the word "Water" cast into them, with an arched bell and foot bottom section. Curb stops shall be placed on a bedding of crushed stone to provide adequate drainage with suitable blocking on each side of the pipe to support the curb box bottom. At no time should the service box bottom rest or contact the service piping. Boxes shall be adjustable for a maximum burial depth of 5.5 feet.
8. One curb box key of appropriate size shall be provided for every 100 services installed of that size.

2.08 TAPPING SADDLES

- A. Service saddles shall be utilized only for all connections to asbestos-cement (transite) pipe. Direct taps shall be made on all other pipe material, including ductile iron and cast iron .
- B. Service saddles, which are to be furnished and installed by the Contractor under these specifications, shall be constructed of Epoxy Coated Ductile Iron with a body curvature designed to fit pipes accurately with a broad pressure activated gasket to provide uniform sealing pressure. Service saddles shall have double straps.
- C. Shall be compatible with approved corporation stops.
- D. The saddle clamp must be furnished with a tapped outlet with full length threads that meet AWWA Standards for corporation stops and shall be from manufacturers on the latest revision of the "List of Approved Materials / Manufacturers for use in the Providence Water Distribution System", or approved substitutes.
- E. The saddle's double straps, bolts, nuts and washers shall be 18-8 stainless steel with all welds passivated for resistance to corrosion. The combined strap width shall be 3-1/4" wide to provide a wide stance on the pipe.
- F. A neoprene or virgin rubber gasket must be bonded into a cavity in the saddle body to provide a pressure tight seal on a water main.
- G. Tapping Saddles for 1-inch services shall only be used if approved or directed by the Engineer. Tapping saddles shall be compatible with approved corporation stops.

2.09 SERVICE TAP REPAIRS

- A. Repair saddle for broken or leaking tap shall be from a single manufacturer on the List of Approved Materials/Manufacturers in Appendix F.
- B. Abandon Corporation Cap for the abandonment of a water service corporation shall be from a single manufacturer on the List of Approved Materials/Manufacturers in Appendix F.

2.10 PITCHER FILTERS AND REPLACEMENT CARTRIDGES

- A. The filters shall be NSF 53 and 42 certified to remove lead under the certification limit at the time of distribution to the customer. The filter shall be:
 - 1. Pitcher filter with replacement cartridges - both the filter and the replacement cartridges shall be certified to the NSF 53 and NSF 42 standards for removal of lead.
 - 2. Provide a minimum 7-cup pitcher filter that supports an NSF 53 and 42 certified filter cartridge.
 - 3. A minimum 6-month supply of filter cartridges must be provided at the time of the replacement. Per the manufacturer's specifications, this may be a single 6-month cartridge that is provided with the pitcher filter or an extra box of three replacement (3) cartridges each with a 2-month lifespan, totaling a minimum of 6-months of supply.
 - 4. Only full boxes shall be provided to the residents. No unopened or repackage boxes shall be provided even if this results in a greater than 6-month supply of filters.
 - 5. Pitchers and filter cartridge shall be by Brita, PUR, ZeroWater, Dupont or equal.
- B. Pitcher filters with replacement cartridges for a minimum 6 month duration shall be provided by the Contractor to each unit in a household following replacements along with instructions for use.
- C. Contractor shall track delivery of pitcher filters in leadCAST, including a photograph confirming the delivery.
- D. Filters shall be stored by the Contractor in a temperature controlled, dry place for a maximum of 6 months in accordance with the manufacturer's recommendations.

PART 3 INSTALLATION

3.01 WATER SERVICE INSTALLATION

- A. Lead service line replacement, testing, and flushing shall be in strict accordance with AWWA C810, latest edition. Water service to the interior plumbing of the building must be shut off before any excavation, or test pits are commenced.
- B. If any portion of the service line is lead, it shall be replaced as a whole, no partial replacements will be allowed.
- C. Unless otherwise approved or directed by the Engineer, all work shall be performed with water mains live and in service. If emergency circumstances or special circumstances approved by Engineer necessitate that water main be temporarily shut down, the water main must be returned to service within 8 hours – no water main shall be out of service for emergencies or special circumstances as approved by the Engineer for longer than 8 hours.

- D. The Contractor shall also install additional interior plumbing equipment as part of the overall interior private service replacement work as shown in Detail No. 1a and 1b in Appendix B. This work shall consist of the installation of ball valves before and after the meter, pressure reducing valve, backflow preventer, and an expansion tank. This work shall also include all appurtenant interior copper piping and fittings required for the completed equipment installations. All materials and installations shall be in accordance with Owner specifications and/or the local plumbing code.
- E. Meters shall be relocated to a higher elevation as shown in Detail No. 1a and 1b in Appendix B when the existing meter is located in a meter pit inside the house. All below grade meter pits shall be filled with concrete that meets the specifications in Section 03301 and Detail No. 1 in Appendix B.
- F. All service connections shall be installed as shown in Detail No. 1a and 1b, Appendix B and shall have a minimum of 4.5 feet of cover unless approved by the Engineer or Owner. Any new service connection that is not installed in the same location as the existing service and is installed in a new location must not be laid in the same trench as other utilities (i.e., gas, electric, sewer).
- G. Care shall be exercised when either pulling or placing and laying copper tubing to be sure that the pipe does not have kinks or sharp bends and to assure against it being in contact with sharp stones or ledge which would cause damage to the pipe. At least 6-inches of sand shall be placed adjacent to and above the service line in open cut locations.
- H. New corporation stops shall be installed at each service and shall be the same size as the new service line diameter. Extract and remove existing corporation stop with an extraction tool and install the new corporation stop matching diameter of new service, in the same penetration unless otherwise approved or directed by the Engineer with the water main live. If existing corporation stop location cannot be reused, notify the Engineer and install a new tap a minimum of 1 ft from the existing tap and 18 inches away from a water main joint. The existing corporation shall be shutoff in a permanent manner, capped/plugged (wood plug with stainless steel strap), abandon Corporation cap, or other approved manner and abandoned. Corporation extraction and installation, direct tapping, repairing, relocation, capping/plugging, and abandonment shall be at no additional cost to the Owner. Rolled copper tubing, curb stops, and necessary adapters and fittings shall be used to make connections between new corporation stops and new and existing service piping.
- I. All valves on the service line and downstream of the meter shall be closed and kept closed until otherwise directed by the Engineer.
- J. During installation of all valves and appurtenances, verify that all items are clean, free of defects in material and workmanship and function properly.
- K. Buried valves shall be cleaned and manually operated to verify that all items are clean, free of defects in material and workmanship and function properly before installation. Buried valves and valve boxes shall be set with the stem vertically aligned in the center of the valve box. Valves shall be set on a firm foundation and supported by tamping pipe bedding material under the sides of the valve. The valve box shall be supported during backfilling and maintained in vertical alignment with the top flush with finish grade.

- L. The drilling and tapping machine shall be rigidly fastened to the pipe. The length of travel of the tap should be so established that when the stop is inserted and tightened per manufacturer recommendations so that no more than one to three threads will be exposed on the outside. When a wet tapping machine is used, the corporation stops shall be inserted with the machine while it is still in place. Corporation stops shall be tightened only sufficiently to give water tightness, and care must be constantly exercised not to overtighten them.
- M. Water service lines shall be installed with a minimum vertical separation distance of 12 inches at all sewer and stormwater utility crossings. Where possible, water service lines shall be installed above sewer utilities in accordance with the applicable State Plumbing Code.
- N. Curb stops will, unless otherwise directed, be installed 1.5-feet from the curb line or pavement limit. Contractor shall be responsible for the removal of existing curb stops and/or installation of curb stops in the locations directed by the Engineer. Install the curb stops and boxes in a workmanlike manner as described herein and as directed by the Engineer and place compacted pea gravel around and below the stop to permit ready draining of the pipe through the waste opening.
 - 1. Curb Boxes shall be set center and plum over curb stops.
 - 2. Set curb box flush with finished grade, except when located in the roadway. If curb box is within a roadway the box shall be set ½-inch below finished grade.

3.02 ELECTRICAL GROUNDING

- A. Prior to performing a replacement involving the private-side (curb to meter), the Contractor shall have a quality inspection performed by a competent person properly trained to check if the existing water pipe is being used for grounding and test for current with a multi-meter. If used for grounding, the Contractor shall perform the following:
 - 1. For a private-side only replacement, install a temporary bonding jumper in parallel with the existing service line, firmly attaching approved grounding clamps to either side of the service line to be repaired, replaced, or reconnected. Contractor shall ensure the connectors are contacting bare (clean) service line material for a metal-to-metal contact. Contractor shall remove temporary grounding after completion of all work and perform a re-inspection by a competent person properly trained to check if the grounding system is properly functioning.
 - 2. For a full replacement (water main to meter), install a temporary bonding jumper in parallel with existing service line from the existing water meter to the existing water main firmly attaching approved grounding clamps to the service line and magnetic connector to the water main ensuring contact with bare (clean) service line and water main material for metal-to-metal contact. For bonding connection to water main, Contractor shall excavate and expose water main and then clean pipe so that magnetic device can make metal-to-metal contact. Contractor shall remove temporary grounding after completion of all work and perform a re-inspection by a competent person properly trained to check if the grounding system is properly functioning.
- B. All work shall be in accordance with the National Electrical Code and City of Providence or Cranston requirements for grounding systems.
- C. Contractor shall perform the work utilizing appropriate Personal Protective Equipment (PPE) and maintain the existing level of electrical grounding through the water service line

replacement process. Do not cut the existing service line until the temporary bonding jumpers are installed.

- D. Once the new copper water pipe is installed, Contractor to connect the pipe to the grounding system with a jumper across the meter for continuity. Existing conditions prior to the replacement shall be restored.
- E. If improper grounding or electrical work is detected, the Contractor shall notify the homeowner who will need to contact an electrician to correct the electrical work in the building before the replacement can commence. No work shall be performed until the improper grounding or electrical work is corrected. If the electrical issue is identified on the day scheduled for replacement at that address, the Contractor will be paid under the Bid Item for “No Access Provided” and will return to the house for the replacement once the homeowner notifies the Contractor that the grounding is corrected.

3.03 FLUSHING AND LEAK TESTING

A. Flushing and Leak Testing

1. When the service line has been installed, prior to backfilling of the access pits or trenches and connecting the customer service, the ball valve shall be closed, and the Contractor shall open the corporation at the water main connection to perform a preliminary flushing and cleaning of the new service piping prior to connection to the existing private-side service piping.
2. After all air is expelled, a visual leakage test is to be conducted on all exposed unions and connections. Test all pipelines for water tightness as specified herein at system pressure. Furnish all labor, testing plugs or caps, pipe connections, gauges and all other equipment required. Testing shall be performed after the line has been constructed and in the presence of the Engineer or the Owner’s representative, and no backfilling of the access pits or trenches will be permitted until the leakage testing is satisfactorily completed.
3. Whereupon the final connection of the new service to the existing private service piping is completed, and the water service is activated, the Contractor will perform a final flushing of the overall service line utilizing the exterior faucet/hose bib of the house or building or by installing a jumper before the water meter or other methods approved by Engineer and shall be performed for a minimum period of fifteen (15) minutes, or in accordance with the latest recommendation in AWWA C810, whichever is greater. If an exterior faucet is not available or is inoperable, and a final flush cannot be performed, the Contractor shall deliver and place a “red” door- hanger notice, as provided by the Owner, at the home (building). This notice will advise the homeowner and/or resident to flush their internal plumbing.
4. When the flush is complete, the final connection shall be made to the water meter and final visual leakage test under “system pressure” will commence for 10 minutes and be observed by Engineer. Repair faulty joints or remove any cracked or defective piping, valves, and fittings and replace as approved by the Engineer. Retest until water service line passes.

- B. The contractor must coordinate with Owner before removing a lead water service from the bypass and shall notify Owner 24 hours prior to the final connection and activation of a new service line connection to an existing lead private side pipe.

C. Partial Replacements

1. If, for any reason, a part of a lead service line cannot be replaced but has been disturbed in any manner, a thirty (30) minute flush of the service line is to be performed and a pitcher filter provided to all units in the building. The Contractor shall inform Owner and Engineer immediately if such a situation arises.
 - a. Flushing shall be performed by installing jumper before water meter or through exterior faucet/hose bib, or other methods approved by Engineer.

D. Flushing Instructions

1. Post-replacement customer flushing instructions shall be left with Customer. These instructions will be provided by the Engineer for the Contractor to distribute.

END OF SECTION

SECTION 02768
PIPE PULLING (EXTRACTION)

PART 1 GENERAL

1.01 SCOPE OF WORK

- A. Furnish all labor, materials, equipment and incidentals required to install new service lines and appurtenances using pipe pulling methods as shown on the water service connection detail and as specified herein.
- B. The Contractor shall be capable of providing crews as needed to complete the work without undue delay.
- C. The Contractor shall be prepared to provide temporary water service to any location that is not completed within the allocated time.
- D. Review and comply with the coordination requirements listed in Section 02663.
- E. Review and comply record-keeping requirements listed in Section 01720.

1.02 RELATED WORK

- A. Trenching, Backfilling, and Compaction are included in Section 02221.
- B. Water Service Connections are included in Section 02663.

1.03 SUBMITTALS

Submit, in accordance with Section 01300, shop drawings for the pipe pulling tool and pulling head.

- A. Submit, prior to the start of work, a typical drawing showing the equipment setup and the size and location of all proposed pits and excavations required to complete the work.
- B. The Owner shall approve or disapprove the Contractor and/or manufacturer based on the submitted information.

1.04 GUARANTEE

- A. All work shall be fully guaranteed by the Contractor for one (1) year from the date of Substantial Completion. During this period, all serious defects discovered by the Customer or Owner shall be removed and replaced in a satisfactory manner by the Contractor at no cost to the Customer or Owner.

PART 2 PRODUCTS

2.01 MATERIAL

- A. Provide and install copper water service line pipe in accordance with Section 02663.

2.02 EQUIPMENT

- A. The pipe pulling tool shall be performed per tool manufacturer's specifications for the application pulled through via a cable installed by a constant tension winch located at the receiving excavation. The pulling unit shall pull the pipe with it as it moves. The pulling head shall incorporate a shield/expander to prevent the collapse of the hole ahead of the pipe insertion.

PART 3 EXECUTION

3.01 GENERAL

- A. Conduct a pre-installation inspection of the property at which pipe pulling is proposed in order to become familiarized each specific site condition (i.e., location of access, conflicting utilities, etc.).
- B. Provide temporary piping in order to maintain water to existing property during pipe pulling if the property will be without water for longer than 8-hours.
- C. Curb stop must be excavated before any other excavation takes place to confirm the service line materials on both sides – the public-owned side and the privately-owned side. If neither side is lead, the excavation shall be backfilled and will be paid for as a test pit.
- D. Excavate access pits as needed along the existing water service line. The number and size of access pits shall be the minimum necessary to allow for satisfactory completion of the work.
- E. Access pits shall be of sufficient size to allow access for pulling equipment and installation of new water service line. All excavation shall be fully braced and supported in accordance with Section 02311. Pits shall be centered over the existing water service line. Maximum pit sizes for payment are shown on the details.
- F. Prior to the actual pipe pulling operation and disconnection of existing water service line, prepare all excavation pits and have all equipment and piping on-site in order to complete the pipe busting or pulling operation in a timely fashion.

3.02 INSTALLATION

- A. The pipe pulling shall be conducted as a continuous operation. Pipe pulling shall consist of pulling specialized head or gripper finger which will install the new water service line. The pulling head shall be sized per manufacture recommendations to prevent breakage of new service line. The new water service line shall be installed straight and parallel to the centerline of the existing water service line following the same line and grade.
- B. Pipe pulling method shall limit vibrations transmitted to the surrounding soils. The peak particle velocity (PPV) shall be limited to 0.5-inches per second.
- C. All buried utilities adjacent to the pipe pulling operation shall be reviewed, and, where necessary, be excavated to relieve transient loading during the pipe pulling operation.
- D. If the water service line is concrete encased employ substitute means to install the new water service line.

- E. The area excavated within the property for the pipe pulling operation shall be repaired, and the new water service line pipe entrance through the building wall shall be fully sealed to provide a watertight seal.
- F. As soon as the pipe pulling operation is complete, connect the new water service line in accordance with Section 02663.

3.03 FIELD TESTING AND ACCEPTANCE

- A. Flushing and testing of the new service line shall be done in accordance with 02663.

END OF SECTION

SECTION 02930
LOAMING AND SEEDING

PART 1 GENERAL

1.01 SCOPE OF WORK

- A. Furnish all labor, materials, equipment and incidentals required and place loam, finish grade, apply lime and fertilizer, apply seed and mulch and maintain all seeded areas to fully restoration of all areas to conditions equal to or better than pre-construction and as specified herein, including all areas disturbed and all existing lawn areas.
- B. As much as feasible, salvage existing sod and grass. Utilize loam and seed to supplement existing sod to restore to existing conditions.

1.02 RELATED WORK

- A. Trenching, Backfilling, and Compaction included in Section 02221.

1.03 SUBMITTALS

- A. Submit, in accordance with Section 01300, complete shop drawings, materials, and equipment furnished under this Section including seed mixtures and product label information.
- B. Samples of all materials shall be submitted for inspection and acceptance upon Engineer's request.

PART 2 PRODUCTS

2.01 MATERIALS

- A. Loam: In accordance with State of Rhode Island, Department of Transportation Standard Specifications for Road and Bridge Construction, Subsection M.18.01.
- B. Starter fertilizer shall be a complete commercial fertilizer, 10-6-4 grade for grass areas. It shall be delivered to the site in the original unopened containers each showing the manufacturer's guaranteed analysis. Store fertilizer so that when used it shall be dry and free-flowing.
- C. Lime shall be ground limestone consisting of a standard commercial product of ground dolomitic limestone intended for agricultural use.
- D. Grass seed shall be equal in mixture to Improved U.R.I. No. 2.
- E. Unrotten straw, hay free of seeds, or salt hay is required on all seeding and shall be applied at a rate of 1.5 to 2 tons/acre (70 to 90 lbs./1,000 square feet). If a crimper is used instead of a liquid mulch-binder, the rate of application shall be 3 tons per acre.
- F. Mulch anchoring shall be a specially processed cellulose fiber containing no growth or germination-inhibiting factors. It shall be manufactured in such a manner that after addition and agitation in slurry tanks with water, the fibers in the material become uniformly suspended to form a homogeneous slurry. When sprayed on the ground, the material shall allow absorption

and percolation of moisture. Each package of the cellulose fiber shall be marked by the manufacturer to show the air-dry weight content.

- G. Other approved mulch anchors include synthetic or organic binders, Peg and twine, mulch netting, and mechanical crimping.

PART 3 EXECUTION

3.01 STRIPPING AND STOCKPILING

- A. 6-inch stripping depth is typical but may vary depending on the soil structure.
- B. Stockpiles shall be located not to obstruct natural drainage, constructed according to the stockpile detail.

3.02 APPLICATION

- A. All areas having lawn or landscaping shall have loam placed to a minimum depth of 5-in (Unsettled).
- B. For all areas to be seeded:
 - 1. Unless otherwise shown on the Details, lime shall be applied at the rate of 0.5 lbs per square yard.
 - 2. Fertilizer shall be applied at the rate of 0.20 lb per square yard.
 - 3. Lawn grass seed shall be applied at the rate of 0.05 lbs per square yard. If the seed is applied by Hydroseeding, then the seed rate shall be increased by 25%
 - 4. Small grain straw mulch shall be applied at the rate of 70 to 90 lbs/1,000 sq ft.
 - 5. Fiber mulch shall be applied by hydroseeding at the rate of 35 lbs/1,000 sq ft.
- C. The application of fertilizer and lime and hydroseeding must be performed separately. Hydroseeding shall be performed as a two-step process applying seed first and covering with mulch second; mulch shall not be mixed with the seed. Seed and mulch must be cleaned from all structures and paved areas of unwanted deposits.

3.03 INSTALLATION

- A. The subgrade of all areas to be loamed and seeded shall be raked, and all rubbish, sticks, roots, and stones larger than 2-in shall be removed. Subgrade surfaces shall be raked or otherwise loosened immediately prior to being covered with loam. Subgrade shall be inspected and approved by the Engineer before loam is placed.
- B. Loam shall be placed over approved areas to a depth sufficiently greater than required so that after natural settlement and light rolling, the complete work will conform to the lines, grades and elevations indicated. No loam shall be spread in water or while frozen or muddy.
- C. After loam has been spread, it shall be carefully prepared by scarifying or harrowing and hand raking. All large stiff clods, lumps, brush, roots, stumps, litter, and other foreign material, shall be removed from the loamed area and disposed of. The areas shall also be free of smaller stones, in excessive quantities, as determined by the Engineer. The whole surface shall then be rolled with a hand roller weighing not more than 100 lbs/ft of width. During the rolling, all

depressions caused by settlement of rolling shall be filled with additional loam, and the surface shall be regraded and rolled until a smooth and even finished grade is created.

- D. Seeding, mulching, and conditioning shall only be performed during those periods within the seasons which are normal for such work as determined by the weather and locally accepted practice, as approved by the Engineer.
- E. Schedules for seeding and fertilizing shall be submitted to the Engineer for approval prior to the work. Landscape work shall only be performed during acceptable growing seasons, as defined for USDA hardiness zone 6b. The customer shall be responsible for the watering of the newly seeded areas to promote satisfactory initial grass growth within the restored grassed areas.
- F. Lime and fertilizer are to be spread mechanically, then:
 - 1. After the loam is placed and before it is raked to true lines and rolled, limestone shall be spread evenly over loam surface and thoroughly incorporated with loam by heavy raking to at least 4-inches of loam.
 - 2. Fertilizer shall be uniformly spread and immediately mixed with the upper 4-inches of topsoil.
- G. Seeding shall be done within 10 days following soil preparation. Seed shall be applied rates and percentages indicated.
- H. In order to prevent unnecessary erosion of newly graded slopes and unnecessary siltation of drainage ways, carry out seeding and mulching as soon as satisfactory completion of a unit or portion of the project. A unit of the work will be defined as not more than 5,000 sq ft.
- I. When protection of newly graded areas is necessary at a time that is outside of the normal seeding season, protect those areas by whatever means necessary (such as straw applied with a tar tack) or by other measures as approved by the Engineer.

3.04 SEEDING IN WOODED AND UNGRADED AREAS

- A. For preparation and seeding in wooded areas under this Contract and where no grading is required, all of the specified materials and procedures shall be utilized except that no disking shall be performed within the drip line of trees to be preserved. The seedbed shall be prepared by the addition of a thin layer of topsoil roughly 1-in deep.

3.05 MAINTENANCE AND PROVISIONAL ACCEPTANCE

- A. Keep all seeded areas watered and in good condition, reseeding if and when necessary until a good, healthy, uniform growth is established over the entire area seeded.
- B. On slopes, provide against washouts by an approved method. Any washout that occurs shall be regraded and reseeded at the Contractor's expense until a good sod is established.
- C. The Engineer will inspect all work for provisional acceptance at the end of the 8-week grass maintenance period, upon the written request, received at least 10 days before the anticipated date of inspection.
- D. A satisfactory stand will be defined as a section of grass of 5 sq ft or larger that has:

1. No bare spots larger than 1 sq ft.
 2. No more than 10 percent of total area with bare spots larger than a 4-inch square.
- E. Furnish full and complete written instructions for maintenance of the lawns to the Customer at the time of provisional acceptance.
- F. The inspection by the Engineer will determine whether maintenance shall continue in any area of manner.
- G. After all necessary corrective work and clean-up has been completed and maintenance instructions have been received by the Customer, the Engineer will certify in writing the provisional acceptance of the lawn areas. Maintenance of lawns or parts of lawns shall cease on receipt of provisional acceptance.

3.06 GUARANTEE PERIOD AND FINAL ACCEPTANCE

- A. All seeded areas shall be guaranteed for not less than 1 full year from the time of provisional acceptance.
- B. At the end of the guarantee period, an inspection will be made by the Engineer upon written request submitted at least 10 days before the anticipated date. Lawn areas not demonstrating satisfactory stands as outlined above, as determined by the Engineer, shall be renovated, reseeded and maintained meeting all requirements as specified herein.
- C. After all necessary corrective work has been completed, the Engineer shall certify in writing the final acceptance of the lawns.

END OF SECTION

SECTION 03301
CONCRETE AND REINFORCING STEEL

PART 1 GENERAL

1.01 SCOPE OF WORK

- A. Furnish all labor, materials, equipment, and incidentals required and install all concrete work complete as shown on the Drawings and as specified herein.

1.02 SUBMITTALS

- A. Submit to the Engineer, in accordance with Section 01300, shop drawings and product data. Submittals shall include at least the following:

- 1. Concrete mix for each formulation of concrete proposed for use including constituent quantities per cubic yard, water-cementitious ratio, type and manufacturer of cement.
- 2. Bar schedules and bar bending details in conformity with the recommendations of ACI 315.
- 3. Technical data on all materials and components.
- 4. Material Safety Data Sheets (MSDS) for all concrete admixtures and curing agents.

- B. Certifications

- 1. Certify concrete proposed will have a minimum 28-day compressive strength as specified.

1.03 QUALITY ASSURANCE

- A. If during the progress of the work, it is impossible to secure concrete of the required workability and strength with the materials being furnished, the Engineer may order such changes in proportions or materials, or both, as may be necessary to secure the desired properties. All changes so ordered shall be made at the Contractor's expense.
- B. Reinforced concrete shall comply with ACI 318.
- C. Ready-Mix-Concrete Manufacturer Qualifications: A firm experienced in manufacturing ready-mixed concrete products, and that complies with ASTM C 94/C 94M requirements for production facilities and equipment.
- D. All testing and inspection services required, unless otherwise specified, shall be provided and paid for by the Contractor. Testing necessary to establish the concrete mixes shall be performed by and at the expense of the Contractor. Methods of testing shall comply with the latest applicable ASTM standards.

1.04 DELIVERY, STORAGE AND HANDLING

- A. Reinforcing steel shall be shipped and stored with bars of the same size and shape fastened bundles with durable tags, marked in a legible manner with waterproof markings showing the same designations as shown on the submitted bar schedules and shop drawings.
- B. Reinforcing steel and Welded Steel Wire Fabric shall be free from mill scale, loose rust, dirt, grease, or other foreign matter. Store off the ground and protect from moisture, dirt, oil, or other injurious contaminants.

- C. Products shall be stored in conformity with the manufacturer's recommendations.
- D. Sand, aggregates, and cement shall be stored or stockpiled in conformity with the recommendations of ACI 301.

1.05 FIELD CONDITIONS

- A. Cold-Weather Concrete Placement: Protect concrete work from physical damage or reduced strength that could be caused by frost, freezing, or low temperatures. Comply with ACI 306.1 and the following:
 - 1. When air temperature has fallen to or is expected to fall below 40 deg F (4.4 deg C), uniformly heat water and aggregates before mixing to obtain a concrete mixture temperature of not less than 50 deg F (10 deg C) and not more than 80 deg F (27 deg C) at point of placement.
 - 2. Do not use frozen materials or materials containing ice or snow.
 - 3. Do not use calcium chloride, salt, or other materials containing antifreeze agents or chemical accelerators unless otherwise specified and approved in design mixtures.
- B. Hot-Weather Concrete Placement: Comply with ACI 301 (ACI 301M) and as follows when hot-weather conditions exist:
 - 1. Cool ingredients before mixing to maintain concrete temperature below 90 deg F (32 deg C) at time of placement. Chilled mixing water or chopped ice may be used to control temperature, provided water equivalent of ice is calculated in total amount of mixing water. Using liquid nitrogen to cool concrete is Contractor's option.

PART 2 PRODUCTS

2.01 MATERIALS

- A. Cement shall be domestic Portland cement conforming to ASTM C150, Type II.
- B. Fine aggregate shall be washed inert natural sand conforming to the requirements of ASTM C33.
- C. Coarse aggregate shall be well-graded crushed stone or washed gravel conforming to the requirements of ASTM C33, size 57 unless otherwise directed.
- D. Water shall be potable, clean, and free from injurious amounts of oils, acids, alkalis, organic matter, or other deleterious substances.
- E. Concrete admixtures shall be free of chlorides and alkalis (except for those attributable to water). When it is required to use more than one admixture in a concrete mix, the admixtures shall be from the same manufacturer. Admixtures shall be compatible with the concrete mix including other admixtures and shall be suitable for use in contact with potable water after 30 days of concrete curing. No admixtures shall be used unless approved by the Engineer in writing.
 - 1. Air-entraining admixture shall comply with ASTM C260. Proportioning and mixing shall be in accordance with manufacturer's recommendations.
 - 2. Water reducing admixture shall comply with ASTM C494, Type A. Proportioning and mixing shall be in accordance with manufacturer's recommendations.

3. Admixtures causing retarded or accelerated setting of concrete shall not be used without written approval from the Engineer. When allowed, the admixtures shall be retarding or accelerating water-reducing admixtures.
- F. Reinforcing steel bars shall be deformed, intermediate grade, steel bars conforming to ASTM A615 Grade 40. Rail-steel bars will not be permitted in the work.
- G. Welded Steel Wire Fabric: Conforming to ASTM A1064.
- H. Tie wires for reinforcing steel shall be 16 gauge or heavier, black annealed wire.
- I. Precast concrete block bar supports shall conform to CRSI - Manual of Standard Practice (MSP) for Precast Concrete Bar Supports.

2.02 CONCRETE QUALITY

- A. Class A concrete, as indicated on Table 1 of Section 601 of the Rhode Island Department of Transportation Standard Specifications for Road and Bridge Construction, shall be designed in accordance with the Rhode Island Department of Transportation Standard Specifications for Road and Bridge Construction, Section 601.02 and Section M.02.

2.03 MIXING CONCRETE

- A. Ready-mix concrete shall conform to ASTM C94 and the requirements herein, or as otherwise approved by the Engineer. If ready-mix concrete is to be used, the manufacturer shall furnish a statement to the Engineer for his approval giving the dry portions to be used, with evidence that these will produce concrete of the quality specified.
- B. Select proportions of ingredients to meet the design strength and materials limits specified and to produce concrete having proper placability, durability, strength, appearance, and other required properties. Proportion ingredients to produce a homogenous mixture which will readily work into corners and angles of forms and around reinforcement without permitting materials to segregate or allowing excessive free water to collect on the surface.

2.04 MEASURING, BATCHING, MIXING AND TRANSPORTING CONCRETE

- A. Measuring, batching, mixing and transporting concrete shall conform to ASTM C94 and the requirements herein, or as otherwise approved in writing by the Engineer.
- B. Ready-mixed concrete, whether produced by a concrete supplier or the Contractor shall conform to the requirements above. No hand mixing will be permitted.
- C. Admixtures shall be dispensed into the batch in conformity with the recommendations of the manufacturer of the admixtures.
- D. Concrete shall be mixed until there is uniform distribution of the materials and shall be discharged completely before the mixer is recharged. The mixer shall be rotated at a speed recommended by the mixer manufacturer and mixing shall be continued for at least 1-1/2 minutes after all the materials are in the mixer. Concrete shall be placed within 1-1/2 hours of the time at which water was first added, otherwise it shall be rejected. Concrete which has been remixed or retempered, or to which an excess amount of water has been added, shall also be rejected.

2.05 FORMS

- A. Forms shall be free from roughness and imperfections, substantially watertight and adequately braced and tied to prevent motion when concrete is placed. No wooden spreaders will be allowed in the concrete.
- B. Wire ties will not be allowed. Metal ties or anchorages which are necessary within the forms shall be so constructed that the metal work can be removed for a depth of at least 1-in from the surface of the concrete without injury to such surface by spalling or otherwise. Forms shall be thoroughly cleaned before using and shall be treated with oil, or other approved material.

PART 3 EXECUTION

3.01 REINFORCING STEEL

- A. Fabricate reinforcing steel accurately to the dimensions shown. Bend bars around a revolving collar having a diameter of not less than that recommended in ACI 318. All bars shall be bent cold.
- B. Provide tension lap splices in compliance with ACI 318. Stagger splices in adjacent bars where possible. Provide Class B tension lap splices at all locations unless otherwise indicated.
- C. Lap splices in welded wire fabric in accordance with the requirements of ACI 318 but not less than 12-in. Tie the spliced fabrics together with wire ties spaced not more than 24-in on center and lace with wire of the same diameter as the welded wire fabric. Offset splices in adjacent widths to prevent continuous splices.
- D. Before being placed in position, reinforcement shall be thoroughly cleaned of loose mill and rust scale, dirt and other coatings, including ice, that reduce or destroy bond. Where there is a delay in depositing concrete after the reinforcement is in place bars shall be reinspected and cleaned when necessary.
- E. Reinforcement which is to be exposed for a considerable length of time after being placed shall be given a heavy coat of cement grout.
- F. In no case shall any reinforcing steel be covered with concrete until the amount and position of the reinforcements have been checked and permission given to proceed by the Engineer.

3.02 INSPECTION AND COORDINATION

- A. The batching, mixing, transporting, placing and curing of concrete shall be subject to the inspection of the Engineer at all times. The Contractor shall advise the Engineer of his/her readiness to proceed at least 24 hours prior to each concrete placement. The Engineer will inspect the preparations for concreting including the preparation of previously placed concrete, the reinforcing steel, and the alignment, cleanliness and tightness of formwork. No placement shall be made without the inspection and acceptance of the Engineer.

3.03 CONCRETE APPEARANCE

- A. Concrete mix showing either poor cohesion or poor coating of the coarse aggregate with paste shall be remixed. If this does not correct the condition, the concrete shall be rejected.

- B. Concrete for the work shall provide a homogeneous structure which, when hardened, will have the required strength, durability and appearance. Mixtures and workmanship shall be such that concrete surfaces, when exposed, will require no finishing. When concrete surfaces are stripped, the concrete when viewed in good lighting from 10-ft away shall be pleasing in appearance and at 20-ft shall show no visible defects.

3.04 PLACING AND COMPACTING

- A. Reinforcement, where required, shall be accurately placed in exact positions shown, shall be secured against displacement with annealed iron wire ties or suitable clips at intersections and shall have a clear space of 2-in between the steel and face of forms unless otherwise indicated. Wire ties passing through the forms for the purpose of holding the steel in proper position will not be allowed. Concrete blocks with wire ties cast therein may be used where approved by the Engineer for the purpose of maintaining the clearance between reinforcement and forms. Reinforcing bars shall be free from rust, scale, dirt, grease, and injurious contaminants.
- B. No concrete shall be placed until forms, the condition of subgrade and method of placement have been approved by the Engineer. Before depositing concrete, all debris, foreign matter, dirt, and water shall be removed from the forms. The contact surface between concrete previously placed and new concrete shall be cleaned and brushed with cement paste.
- C. Concrete shall not be placed in water or submerged within 24 hours after placing, nor shall running water be permitted to flow over the surface of fresh concrete within 4 days after its placing.
- D. Deposit concrete as near its final position as possible to avoid segregation due to rehandling or flowing. Pumping of concrete will be permitted when an approved design mix and aggregate sizes, suitable for pumping, are used. Do not deposit concrete which has partially hardened or has been contaminated by foreign materials. If the section cannot be placed continuously, place construction joints as specified or as approved. Do not drop concrete more than 4-ft.
- E. High-frequency mechanical vibrators shall be used to the extent necessary to obtain proper consolidation of the concrete, but not to move or transport concrete in the forms. Care shall be taken to avoid segregation of aggregates by excess vibration. Vibration shall continue until the frequency returns to normal, trapped air ceases to rise and the surface appears liquefied, flattened and glistening. Concrete adjacent to forms and around pipe stubs shall be carefully spaded or rodded.
- F. No concrete shall be mixed or placed during freezing weather without explicit permission. When placing concrete when the air temperature is below 40 degrees F, the water, sand, and gravel shall be heated so that the temperature of the concrete will be at least 50 degrees F. This temperature shall be maintained for 72 hours after placing. No concrete shall be placed on the frozen ground.
- G. Preformed expansion joint filler shall be placed adjacent to structures as directed.
- H. Concrete walkways shall be placed in such quantity that, after being thoroughly consolidated in place, it shall be 4-in in depth. Finishing operations shall be delayed until all bleed water and water sheen has left the surface and concrete has started to stiffen. After water sheen has disappeared, edging operations shall be completed. After edging and jointing operations, the surface shall be floated with an aluminum or magnesium float. Immediately following floating, the surface shall be steel troweled. If necessary, tooled joints and edges shall be rerun before

and after troweling to maintain uniformity. Finish shall match as near as possible the original finish.

- I. The curb face shall be equal to the face of the adjacent undisturbed curb, and the type (i.e., stand up curb or gutter curb) shall be replaced in kind to a condition equal to or better than that which existed previously. Curb that is broken or cracked during construction operations shall be removed and disposed and replaced of by the Contractor at his own expense.

3.05 CURING AND PROTECTION

- A. Protect all concrete work against injury from the elements and defacements of any nature during construction operations.
- B. All concrete shall be cured in conformity with ACI 301. Concrete that is to be used for the containment of water shall be water cured. Water curing shall be by ponding, by continuous sprinkling or by covering with continuously saturated burlap.
- C. Other concrete shall be cured by either water curing, sheet material curing or liquid membrane curing compound except that liquid membrane curing compound shall not be used on any concrete surface where additional concrete is to be placed or where the concrete surface is to be coated or painted.
- D. Finished surfaces and slabs shall be protected from the direct rays of the sun to prevent checking and crazing.
- E. Concrete placed during cold weather shall be batched, delivered, placed, cured and protected in compliance with the recommendations of ACI 306R. Salt, manure or other chemicals shall not be used for cold weather protection.
- F. Concrete placed during hot weather shall be batched, delivered, placed, cured and protected in compliance with the recommendations of ACI 305R. The temperature of the concrete shall be such that it will cause no difficulties from loss of slump, flash set or cold joints. Immediately cover the plastic concrete with sheet material during hot weather.

3.06 CONCRETE ENCASEMENTS AND THRUST BLOCKS

- A. Concrete encasements shall be placed as directed by the Engineer. Backfill shall not be placed on the concrete until permitted by the Engineer.
- B. The backs of thrust block anchors shall be placed against undisturbed earth. The sides of thrust blocks shall be formed. Minimum bearing area shall be as designated by the Engineer. Felt roofing paper shall be placed to protect pipe joints. Concrete shall not be placed over bolts or nuts, or to prevent the removal of joints.

3.07 FIELD TESTS

- A. With the start of any new concrete mix, sets of three field control cylinder specimens will be taken by the Contractor during the progress of the work as directed by Engineer, in compliance with ASTM C31. The number of sets of concrete test cylinders taken of each class of concrete shall be determined by the Engineer. One cylinder shall be broken at 7 days and two cylinders shall be broken and their strengths averaged at 28 days. When the average 28 day compressive strength of the cylinders in any set falls below the specified compressive strength or below proportional minimum 7 day strengths (where proper relation between 7 and 28 day strengths have been established by tests); the Engineer may reject the concrete represented by the set of

cylinders, may require modification of the concrete and/or require modification of the proportions, water content, or temperature conditions of the design mix to achieve the required strengths.

- B. Cooperate in the making of tests by allowing free access to the work for the selection of samples, providing an insulated closed curing box for specimens, affording protection to the specimens against injury or loss through his/her operations and furnishing material and labor required for the purpose of taking concrete cylinder samples. All shipping of specimens will be paid for by the Contractor.
- C. Slump tests will be made in the field by the Contractor in conformity with ASTM C143.
- D. Tests for air content shall be made in compliance with either the pressure method complying with ASTM C231 or by the volumetric method complying with ASTM C173.

3.08 STRIPPING AND FINISHING CONCRETE

- A. Forms shall not be stripped before the concrete has attained a strength of at least 30 percent of the specified design strength unless otherwise approved by the Engineer. This is equivalent to approximately "100 day-degrees" of moist curing.
- B. Care shall be exercised to prevent damaging edges or to obliterate the lines of chamfers, rustications or corners when removing the forms or doing any other work adjacent thereto.
- C. Clean all exposed concrete surfaces and adjoining work stained by leakage of concrete, to the satisfaction of the Engineer.
- D. As soon as forms have been stripped, form ties, if employed, shall be removed, and the recess filled to ensure complete water tightness. Any defects in the surface of the walls shall be chipped out and repaired in a workmanlike manner. Defective concrete where it occurs shall be cut to a minimum depth of 1-in, thoroughly roughened and neat cement brushed in. The hole shall then be filled with mortar in the proportion of 1 part cement and 2-1/2 parts sand with a minimum of water. Mortar for filling form tie recesses shall be mixed to a slightly damp consistency (just short of "balling"), pressed into the recess until dense, and troweled smooth. Mortar in larger patches shall be applied and allowed to assume a partial set following which it shall be struck off flush with the adjoining surface.
- E. Patches shall be kept moist for several days to assure proper curing.
- F. Concrete to receive damp proofing and concrete not exposed in the finished work shall have off-form finish with fins, and other projections removed and tie cones and defects filled as specified.
- G. Sidewalks broken or cracked as a result of the construction operations shall be removed and disposed of by the Contractor and replaced in their entirety to the nearest joint at the Contractor's own cost.

END OF SECTION

SECTION 15050
INTERIOR PIPING - GENERAL REQUIREMENTS

PART 1 GENERAL

1.01 SCOPE OF WORK

- A. This Section specifies the basic administrative and testing requirements for interior piping. Specific piping materials, systems, and installation procedures are specified in Section 15410.
- B. The existing plumbing systems, including piping and equipment, shall remain in operation until the new water service line is in service. All systems shall be maintained without interruption. The demolition and removal work shall be coordinated with the Owner, Customer and construction schedule for the new water service line.
- C. The temporary shutdown of the individual water system for service transfer shall be limited to 8-hours.
- D. Field verify all piping and plumbing systems to be removed and perform the removal work as required to provide complete and safe transfer of service.
- E. All plumbing demolishing work shall be performed following State plumbing codes and Owner requirements by a Plumber licensed in the State of Rhode Island.

1.02 RELATED WORK

- A. Interior Service Piping and Appurtenances are included in Section 15410.
- B. Water Service Connections are included in Section 02663.

1.03 SUBMITTALS

- A. Submit, in accordance with Section 01300, general submittals for piping and piping systems as listed below. It is not intended that all submittals listed below be provided for all piping materials and systems. Refer to individual System or Piping Sections for specific submittals.
- B. This project is funded in part by the Rhode Island Infrastructure Bank via the Drinking Water State Revolving Fund (DWSRF). As part of that program, iron and steel materials and equipment shall meet the American Iron and Steel requirements. Provide a certificate of compliance with the shop drawings for items in this section.
- C. Shop Drawings and Product Data
 - 1. Pipe hangers and supports technical data
 - 2. Catalog cuts of joints, couplings, harnesses, expansion joints, gaskets, fasteners, and other accessories.
- D. Manufacturers Installation (or application) instructions.

1.04 WARRANTY:

- A. Warrant the Work against defects for one (1) year from the date of Substantial Completion.

1.05 QUALITY ASSURANCE

- A. All materials shall be new and unused.
- B. Install piping to meet the requirements of all local codes.
- C. Provide manufacturer's certification that materials meet or exceed minimum requirements as specified. Reference to standards such as ASTM and ANSI shall apply to those versions in effect at the time of bid opening.
- D. Unless otherwise specified, pressures referred to in all Piping Sections are expressed in pounds per square inch gauge above atmospheric pressure, psig and all temperatures are expressed in degrees Fahrenheit (F).

1.06 DELIVERY, STORAGE AND HANDLING

- A. During loading, transportation and unloading take care to prevent damage to pipes and coating. Carefully load and unload each pipe under control at all times. Place skids or blocks under each pipe in the shop and securely wedge pipe during transportation to ensure no injury to pipe and lining.

PART 2 PRODUCTS

2.01 MATERIALS

- A. Specific piping materials and appurtenances are specified in the respective Piping or System Sections.
- B. General installation materials shall be as specified below.
 - 1. Unions shall be brass or bronze unions for joining nonferrous pipe.

PART 3 EXECUTION

3.01 GENERAL

- A. All dirt, scale, weld splatter, water, and other foreign matter shall be removed from the inside and outside of all pipe and sub-assemblies prior to installing.
- B. All pipe joints and connections to equipment shall be made in such a manner as to produce a minimum of strain at the joint.
- C. Install piping in a neat manner with lines straight and parallel or at right angles to walls or column lines and with risers plumb. Run piping so as to avoid passing through ductwork or directly under electric light outlets and/or interference with other lines. All work shall be accomplished using recognized methods and procedures of pipe fabrication and in accordance with the latest revision of applicable ANSI Standards, ASME Codes and Pipe Fabrication Institute Standards.
 - 1. Use the full length of pipe except where cut lengths are necessary. Do not spring or deform piping to make up joints.

2. Pipe shall be cut square, not upset, undersized or out of round. Ends shall be carefully reamed and cleaned before being installed.
 - a. Pipe bending shall only be done with mechanical bending equipment only. The minimum radius of a bend for 1-inch copper type K tubing is 4-inches, minimum radius of a bend for 1¼ -inch copper type K tubing is 9-inches. Pipe of different materials or sizes shall follow trade/authoritative reference for all bends.
3. Do not use bushings except where specifically approved by the Engineer. Reducers shall be eccentric to provide for drainage from all liquid-bearing lines and facilitate air removal from water lines.
4. Verify the locations and elevations of any existing piping and manholes before proceeding with work on any system. No claim for extra payment will be considered if the above provision has not been complied with.
5. Where lines of lower service rating tie into services or equipment of higher service rating the isolation valve between the two shall conform to the higher rating.
6. Mitering of pipe to form elbow is not permitted.
7. All piping interiors shall be thoroughly cleaned after installation and kept clean by approved temporary closures on all openings until the system is put in service. Closures should be suitable to withstand the hydrostatic test.
8. End caps on pre-cleaned pipe shall not be removed until immediately before assembly. All open ends shall be capped immediately after completion of installation.

3.02 UNIONS

- A. Use unions to allow the dismantling of pipes, valves, and equipment.
 1. Unions shall be provided where indicated and in the following locations even if not indicated.
 - a. In long runs of piping to permit convenient disassembly for alterations or repairs.

3.03 LEAK TESTING AND DISINFECTION

- A. Refer to Sections 02663, 02616, and 15410 for testing and flushing processes.

END OF SECTION

SECTION 15410
INTERIOR SERVICE PIPING AND APPURTENANCES

PART 1 GENERAL

1.01 SCOPE OF WORK

- A. This Section specifies the basic interior service line piping, including the methods of installation for copper pipe and tubing, valves and associated appurtenances as shown in project details or as needed in the field.
- B. Furnish all labor, materials, equipment, services, and incidentals required and install complete and connect interior service piping to existing building plumbing system as shown in project details and as specified herein. If not present install an electrical jumper across meter per National Electrical Code and install grounding as specified in Section 02663.
- C. The installation of the new water service line for each property has not been individually detailed. The water service line connection details in Appendix B were developed to illustrate to the Contractor the required plumbing elements and the required order of the plumbing elements to be used. The piping and equipment shown on the water service line connection details are not to scale and do not show every offset or fitting, nor every hanger or support, or structural difficulty that may be encountered. To carry out the intent and purpose of the water service line connection, Contractor shall field verify all piping and plumbing systems to ensure all necessary plumbing parts are installed to provide a complete and safe transfer of the domestic water service without extra charge to the Owner or Customer. The Contractor shall be responsible for coordinating the system installation and routing with the work of all trades.

1.02 RELATED WORK

- A. Pipe Penetrations is included in Section 01180.
- B. Water Service Connections is included in Section 02663.
- C. Piping – General Requirements are included in Section 15050.

1.03 SUBMITTALS

- A. Submit, in accordance with Section 01300, and within 10 days after issuance of a Notice to Proceed a list of materials to be furnished, the name of suppliers and the date of delivery of materials on the job site.
- B. Submittals shall include a representative catalog cut for each different type of item indicating the materials of construction, important dimensions, and range of pipe sizes for which that item is suitable and structural fasteners to be used.
- C. Submittals shall include jumper wire material, attachment device UL listing and schematic and installation procedures.
- D. This project is funded in part by the Rhode Island Infrastructure Bank via the Drinking Water State Revolving Fund (DWSRF). As part of that program, iron and steel materials and

equipment shall meet the American Iron and Steel requirements. Provide a certificate of compliance with the shop drawings for items in this section.

1.04 SERVICE AND UTILITY CONNECTIONS

A. Water Service

1. The source of water for potable use in the building shall be brought into the building and connected to the water meter.

1.05 QUALITY ASSURANCE

- A. All products and materials provided for potable water service application shall be certified “lead-free,” by an ANSI certified, third-party independent organization. The term “lead-free” shall refer to the wetted surface of the pipe, fittings, and fixtures in potable water systems that have a weighted average lead content less than or equal to 0.25 percent per the Safe Drinking Water Act (Sec. 1417) amended in 2020 and other equivalent state regulations.
- B. All products of a given type included in this Section shall be furnished by or through a single manufacturer or as specified on the schedules.
- C. Inspection by the Engineer's representative or failure to inspect shall not relieve the Contractor of responsibility to provide materials and perform the work in accordance with the documents.
- D. The piping manufacturer shall furnish an affidavit of compliance certifying that all materials used and work performed complies with the specified requirements. Provide copies of the mill test confirming the type of material used in the various components.
- E. All the types of valves and appurtenances shall be the product of well-established firms who are fully experienced, reputable and qualified in the manufacture of the equipment to be furnished. The equipment shall be designed, constructed and installed in accordance with the best practices and methods and shall comply with this Section as applicable.
- F. The Owner and Engineer reserve the right to sample and test any materials after delivery and to reject all components represented by a sample that fails to comply with the specified requirements.
- G. All interior plumbing work shall be performed following State plumbing codes and Owner requirements by a Plumber licensed in the State of Rhode Island. A plumber shall be on site each day replacements that involve the private side (curb to meter) are occurring.

1.06 DELIVERY, STORAGE AND HANDLING

- A. All materials shall be inspected for size, quality, and quantity against approved shop drawings upon delivery.
- B. Delivery schedule of all equipment shall be coordinated with the Contractor. Equipment ready for shipment prior to the agreed upon shipping date shall be stored without cost to the Owner by the manufacturer.

- C. All materials shall be suitably packed for shipment and long-term storage. Each package shall be labeled to indicate the project and the contents of each package. Where applicable, equipment numbers shall be marked on the container.
- D. All equipment shipped that is exposed such as on a flatbed truck shall be protected during transit. The equipment shall be protected from moisture, road salt, dirt, stones or other materials thrown up from other vehicles. Electrical components shall be protected as above, but with special attention to moisture. The method of shipment protection shall be defined in the submittals.
- E. All materials shall be stored in a covered dry location off the ground. When required to protect the materials they shall be stored in a temperature-controlled location.

1.07 COORDINATION

- A. Project details indicate the extent and general arrangement of the systems. If any departures from the details or specifications are deemed necessary, details of such departures and the reasons, therefore, shall be submitted as soon as practical for review. No such departures shall be made without the prior written concurrence of the Engineer.
- B. Assume full responsibility for coordination of the individual property plumbing systems, including scheduling and verification that all structures, piping and the mounting of equipment are compatible.

1.08 WARRANTY:

- A. Warrant the work against defects for one (1) year from the date of Substantial Completion.

PART 2 PRODUCTS

2.01 SERVICE PIPING

- A. Interior Copper Service piping shall be Type "L" or Type "K" copper meeting ASTM B-88 and NSF/ANSI 61 requirements with a maximum working pressure of 200 psi.
- B. If and when required, the Contractor shall also install additional interior plumbing equipment as part of the overall interior private service replacement work. This work will consist of the installation of new pressure reducing valve before the water meter, and the installation of a new expansion tank. This work will also include all appurtenant interior copper piping and fittings required for the completed equipment installations. All materials and installations shall be in accordance with Owner specifications and/or the local plumbing code.

2.02 JOINING OF PIPE

- A. Soldering
 - 1. Type S-1, Solder Alloy TC (95 percent Tin, 4.85 percent Copper 0.15 percent Selenium), ASTM B32, lead-free, certified to comply with ANSI/NSF 61. No solder containing lead shall be utilized on the project.

2.03 VALVES

A. Ball Valves

1. Ball valves of the same size as the service line shall be furnished and installed by Contractor within building interior upstream and downstream of the meter. All valves and appurtenances shall have the name of the maker, flow directional arrows and the working pressure for which they are designed cast in raised letters upon some appropriate part of the body.
2. Adapter couplings for connecting new copper tubing to existing non-lead service connections (for public side only or private side only service replacements as part of this work as approved by Engineer) shall be standard straight coupling fittings conforming to AWWA C800. When connecting new water service to existing water service, the Contractor may encounter different pipe materials such as steel, brass, etc. Couplings used to connect new to existing services shall electrically isolate the two materials and be comprised of corrosion resistant material. Contractor shall use caution to ensure that the electric ground of existing buildings is not disrupted or altered.
3. The body and cap shall be of brass, ASTM B30, the ball and stem of Type 316 stainless steel, and the seats of the seals of TFE. The valves shall have full floating ball and shall be non-lubricated. Valve seats shall be easily accessible and replaceable. Valves shall be rated to 200 psi. Ball valves shall be quarter turn and complete with an integral bleeder valve on the side.
4. Lead-free water valves 2-in and smaller shall be full port ball type with integral bleeder valve on the side.
 - a. Manufacturers:
 - 1) As listed in Appendix F.
 - 2) Approved equal.
5. Ferrous surfaces not to be painted shall be given a shop coat of grease or other suitable rust-resistant coating.

2.04 EXPANSION TANKS

- A. The expansion tanks shall be Amtrol Model ST-5 in-line model expansion tanks with an appropriate capacity determined by the licensed plumber and as required by Rhode Island Plumbing Code.

2.05 BACKFLOW PREVENTOR

- A. Backflow preventer for residential applications shall be a lead-free brass dual-check backflow preventer for potable water with a minimum working pressure of 150 psi.
- B. Backflow preventers for multi-family, commercial, and industrial applications shall provide backflow preventor in accordance with Providence Water's Cross Connection Program: <https://provwater.com/backflow/crossconnectionprogram>.

2.06 PIPE HANGERS, SUPPORTS AND RESTRAINTS

- A. All pipe and tubing shall be supported as required to prevent significant stresses in the pipe or tubing material, valves, fittings, and other pipe appurtenances, and to support and secure the pipe in the intended position and alignment. All supports shall be designed to adequately secure the pipe against excessive dislocation due to thermal expansion and contraction, internal flow forces, and all probable external forces such as equipment, pipe and personnel contact.
- B. The absence of pipe supports in the details shall not relieve the Contractor of the responsibility for providing them.
- C. Pipe supports shall not induce point loadings but shall distribute pipe loads evenly along the pipe circumference.
- D. Supports shall be provided at changes in direction or as specified herein. No piping shall be supported from other piping or stairs unless specifically directed or authorized by the Engineer.
- E. Materials of Construction for copper piping:
 - 1. Supports for copper pipe shall be copper plated or shall have a 1/16-in plastic coating.
 - 2. Support spacing for copper piping and tubing 2-in and smaller diameter shall not exceed 5-ft and greater than 2-in diameter shall not exceed 8-ft.
 - 3. Where pipe supports come in contact with copper piping, provide protection from galvanic corrosion by wrapping pipe with 1/16-in thick neoprene sheet material and galvanized protection shield; isolators similar to Elcen, or copper-plated or PVC-coated hangers and supports.
- F. Anchoring Devices: select size, and space support anchoring devices, including anchor bolts, inserts, and other devices used to anchor support, to withstand shear, and pullout loads imposed by loading and spacing on each particular support. Expansion anchors shall be equal to Kwik Bolt as manufactured by Hilti USA, Tulsa, Oklahoma; or Wej-it by Wej-it Expansion Products, Inc., Broomfield, CO. The length of expansion bolts shall be sufficient to place the wedge portion of the bolt a minimum of 1-in behind the steel reinforcement.

2.07 WATER METER

- A. Immediately notify the Owner of any home that does not have a water meter installed.

2.08 REDUCED PRESSURE ZONE BACKFLOW PREVENTER

- A. Reduced Pressure Zone Backflow Preventer (RPZ) shall be a lead-free cast copper assembly for potable water with a minimum working pressure of 150 psi.
- B. RPZs are required for high hazard applications per Table 608.1 of the State of Rhode Island Plumbing Code. Providence Water's Cross Connection Control Program classifies commercial buildings and apartment buildings with four (4) or more units as a Level III buildings, which is a high hazard. A high hazard classification requires an RPZ.

PART 3 EXECUTION

3.01 INSTALLATION

- A. Install all piping, valves, hangers and appurtenances as specified herein and in the referenced Sections above.
- B. Do not install any equipment or materials until the Owner and Engineer have approved all submittals. If any equipment or materials are installed prior to approval of the submittals, it shall be at the Contractor's risk.
- C. If the Contractor is unable to perform work for any reason, the Contractor shall call the Engineer regarding replacing the interior piping system and provide temporary water to the water meter before departing the site.
- D. Carefully cut and remove drywall as needed to access the meter and service line with approval from the Homeowner. Restoration of drywall is to be paid for under Items 2A, 2B, 3A, or 3B as applicable.
- E. Reductions in size shall be made using reducing fittings.
- F. Install all brackets, extension rods, guides, the various types of operators and appurtenances as shown in the details that are in masonry floors or walls and install concrete inserts for hangers and supports as soon as forms are erected and before concrete is poured. Before setting these items, check all plans and figures which have a direct bearing on the proper location of these valves and appurtenances during the construction of the structures.
- G. All materials shall be carefully inspected for defects in workmanship and materials; all debris and foreign material cleaned out of valve openings, etc; all operating mechanisms operated to check their proper functioning and all nuts and bolts checked for tightness. Valves and other equipment which do not operate easily, or are otherwise defective, shall be repaired or replaced at no additional cost to the Owner.
- H. After installation, remove debris and excess material from the construction area. If miscellaneous objects had been relocated to obtain access to the meter, after Customer approval, those items shall be placed back in their original location prior to construction.
- I. Valves
 - 1. Install valves in locations grouped and located to be easily operated through access panels, doors, or adjacent to equipment.
 - 2. Install valves in a horizontal to upright position. Valves shall not be installed in down position from the horizontal.
 - 3. In making solvent cement connections, the solvent cement or primer shall not be spilled on valves. Any cement allowed to run from joints shall be cleaned from the pipe and fittings immediately.
- J. Soldering
 - 1. Piping shall be cut with square ends and reamed to prevent burrs, out-of-round or improperly sized ends.

2. After cutting, all surfaces to be soldered shall be thoroughly cleaned to a metal-bright finish, free from dirt, grease or other material before fluxing and soldering. This cleaning shall be performed by using emery cloth, sandpaper or steel wool. Clean the outside end of the tubing for a length of 1/2-inch greater than the depth of the fitting. The inside of the fittings shall be cleaned in a similar manner. Apply flux and assemble the joint.
3. The surfaces to be joined shall be heated up slowly and uniformly to the melting point of the solder. The surface being soldered shall be maintained above the melting point of the solder for sufficient time to draw the solder completely into the joint. When the solder congeals to a plastic state, the excess metal shall be removed with a cloth brush, leaving a fillet around the end of the fitting. Full penetration of the solder uniformly throughout the entire socket is required. The soldered joints shall be allowed to cool in still air until only warm to the hand after which the work may be quenched.
4. Any type of crack, pinhole, area of incomplete penetration, or similar defect shall not be accepted. Peening for closing up defects shall not be permitted.
5. Heating torches of sufficient size shall be used for heating of large fittings prior to soldering. Multiple tips or ring burners for use on combination torches may be used.
6. Remove all external and internal loose solder and flux after joint cools.

K. Hangers and Supports

1. Existing hangers and supports shall be re-used for the interior service line piping.
2. Install support systems in accordance with MSS SP69 and MSS SP89. Install pipe anchors where required to withstand expansion thrust loads and to direct and control thermal expansion.
3. Repair mounting surfaces to original condition after attachments are made.

L. Meters

1. If the water meter is broken or missing, Contractor shall notify Owner to replace meter.

3.02 LEAK TESTING AND FLUSHING

- A. All pipe support systems shall be tested after installation in conjunction with piping flushing and leak testing. If any part of the pipe support system proves to be defective or inadequate, it shall be repaired to the satisfaction of the Engineer.
- B. Refer to Section 02663 for leak testing and flushing processes.
- C. Flushing shall be in strict conformance with the methods described in AWWA C810 and shall be done inside the home at the meter bypass even when only the public side of the service line is replaced.
- D. Instructions for the resident for continued flushing after the Contractor's flushing immediately following the installation shall be provided to each resident in the home where the line is replaced.

3.03 RESTORATION

- A. Clean up any construction debris and dust from the replacement. Remove all equipment and materials. Replace any removed drywall with new drywall and tape as required or directed by

the Engineer or Owner. Replace any removed flooring with new flooring as required or directed by the Engineer or Owner.

END OF SECTION

Appendix A

Contract Addresses (Initial List)

Ward	Number of Properties
Providence	
7	140
8	450
9	340
15	80
Cranston	
3	40
5	170

Note, values are rounded for reporting purposes.

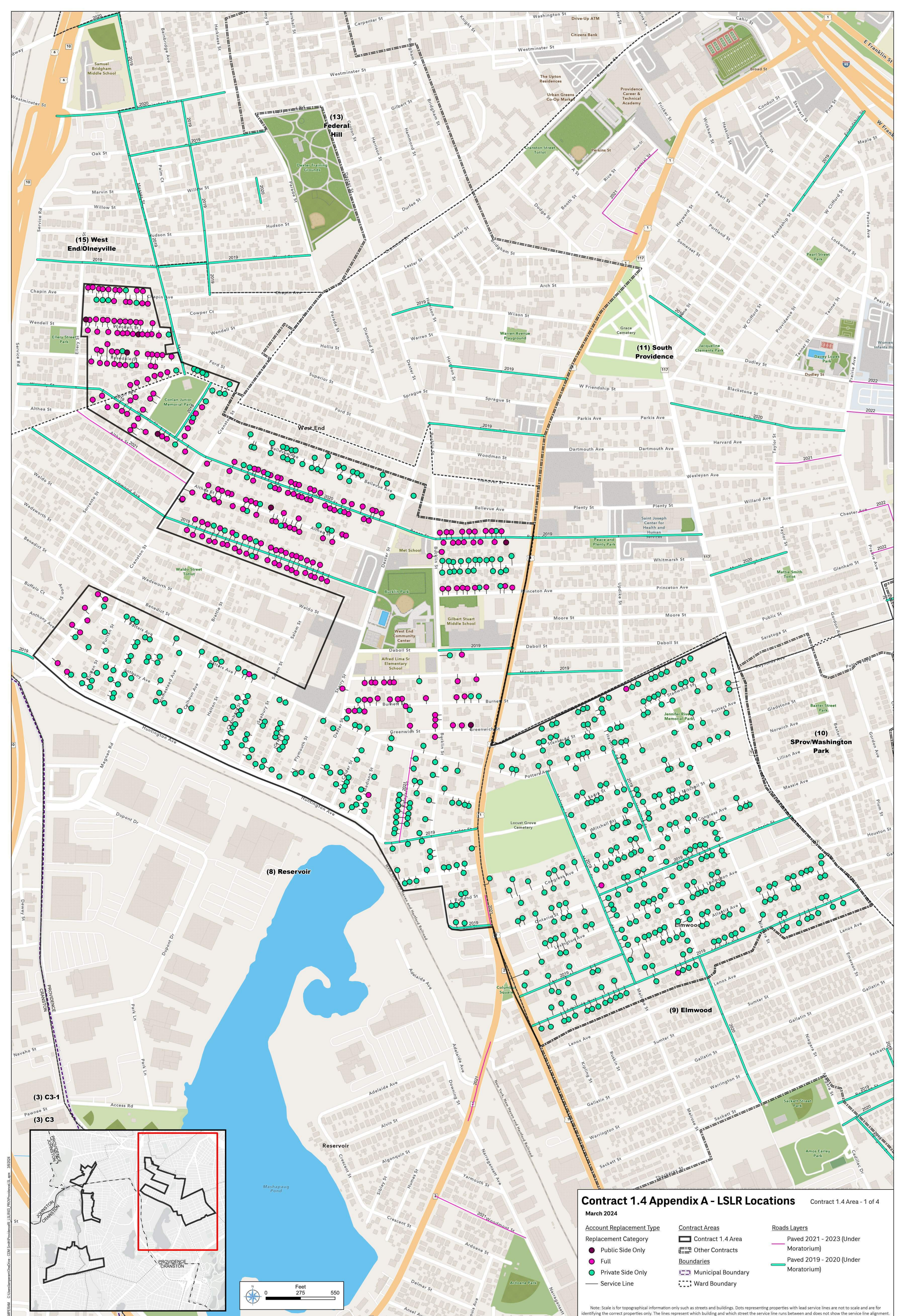

Contract 1.4 Appendix A - LSLR Locations Contract 1.4 Area - 1 of 4

March 2024

Account Replacement Type	Contract Areas	Roads Layers
Replacement Category	Contract 1.4 Area	Paved 2021 - 2023 (Under Moratorium)
● Public Side Only	Other Contracts	Paved 2019 - 2020 (Under Moratorium)
● Full	Boundaries	
● Private Side Only	Municipal Boundary	
— Service Line	Ward Boundary	

Note: Scale is for topographical information only such as streets and buildings. Dots representing properties with lead service lines are not to scale and are for identifying the correct properties only. The lines represent which building and which street the service line runs between and does not show the service line alignment.

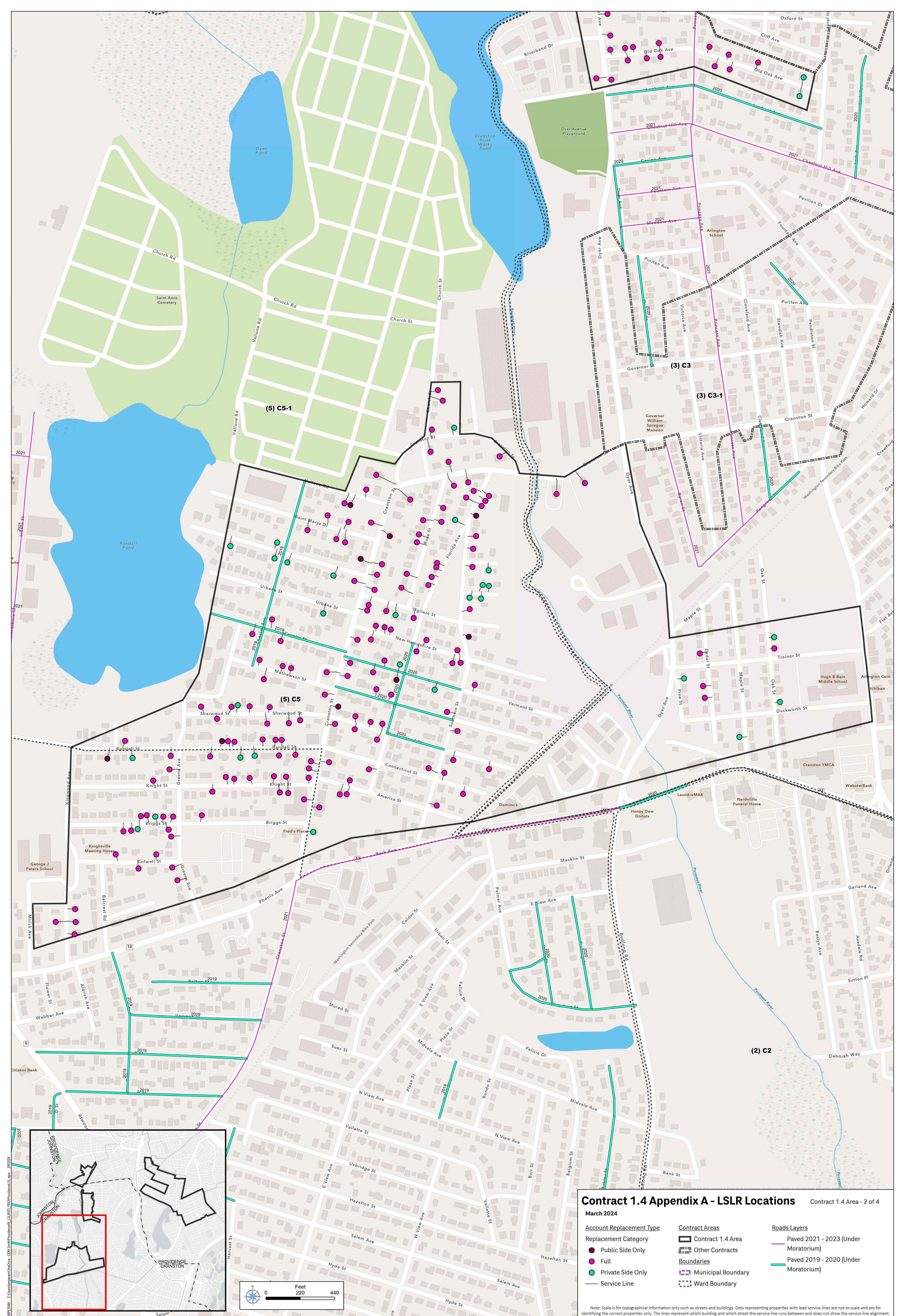

Contract 1.4 Appendix A - LSLR Locations Contract 1.4 Area - 2 of 4
 March 2024

<p>Account Replacement Type</p> <p>Replacement Category</p> <ul style="list-style-type: none"> ● Public Side Only ● Full ● Private Side Only — Service Line 	<p>Contract Areas</p> <ul style="list-style-type: none"> ▭ Contract 1.4 Area ▭ Other Contracts <p>Boundaries</p> <ul style="list-style-type: none"> ▭ Municipal Boundary ▭ Ward Boundary 	<p>Roads Layers</p> <ul style="list-style-type: none"> — Paved 2021 - 2023 (Under Moratorium) — Paved 2019 - 2020 (Under Moratorium)
--	--	---

Note: Scale is for topographical information only such as streets and buildings. Dots representing properties with lead service lines are not to scale and are for identifying the correct properties only. The lines represent which building and which street the service line runs between and does not show the service line alignment.

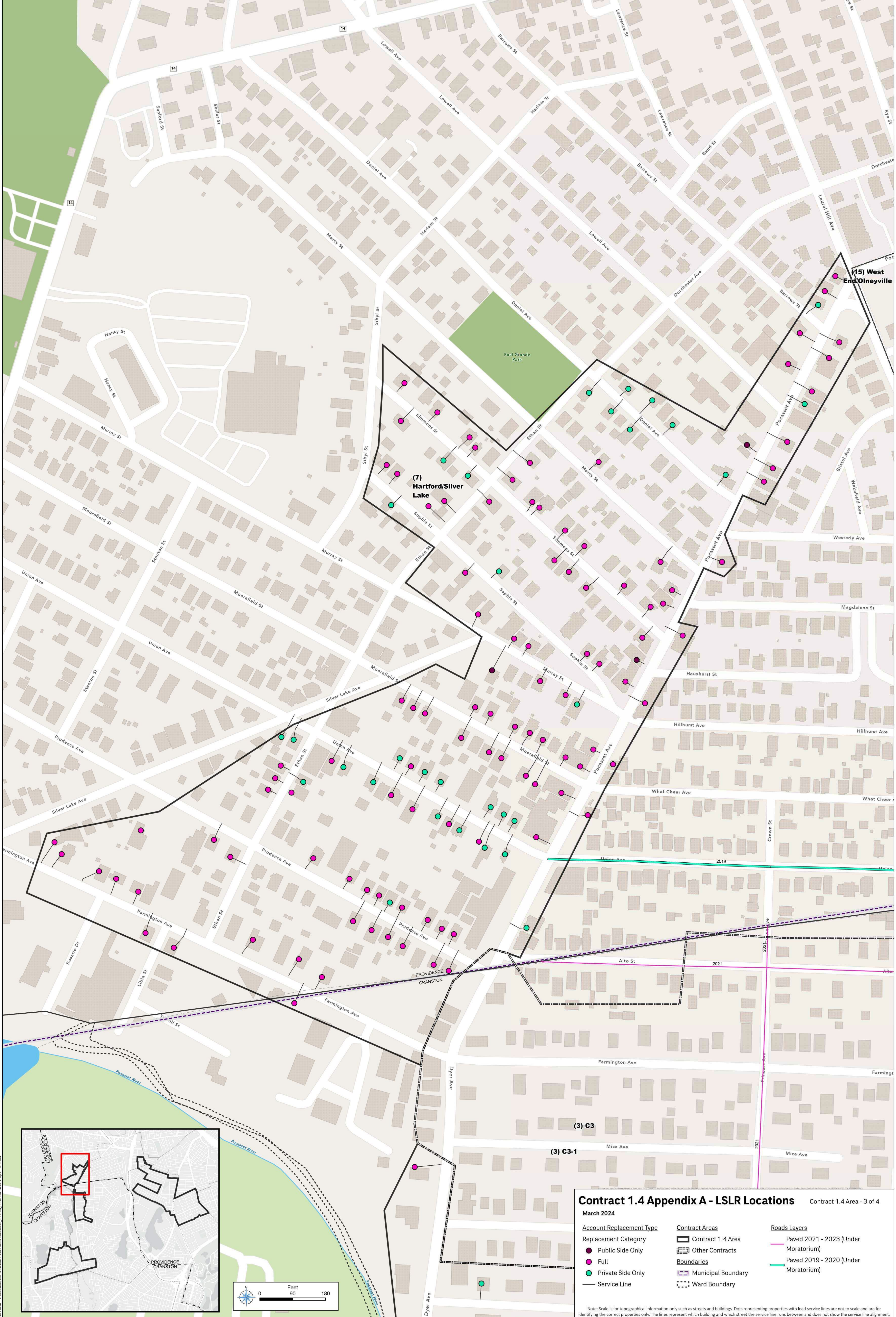

(7) Hartford/Silver Lake

(15) West End/Olneyville

(3) C3

(3) C3-1

Contract 1.4 Appendix A - LSLR Locations

Contract 1.4 Area - 3 of 4

March 2024

<p>Account Replacement Type</p> <p>Replacement Category</p> <ul style="list-style-type: none"> ● Public Side Only ● Full ● Private Side Only — Service Line 	<p>Contract Areas</p> <ul style="list-style-type: none"> ▭ Contract 1.4 Area ▭ Other Contracts ▭ Boundaries ▭ Municipal Boundary ▭ Ward Boundary 	<p>Roads Layers</p> <ul style="list-style-type: none"> — Paved 2021 - 2023 (Under Moratorium) — Paved 2019 - 2020 (Under Moratorium)
--	--	---

Note: Scale is for topographical information only such as streets and buildings. Dots representing properties with lead service lines are not to scale and are for identifying the correct properties only. The lines represent which building and which street the service line runs between and does not show the service line alignment.

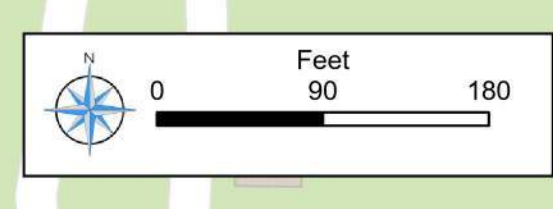
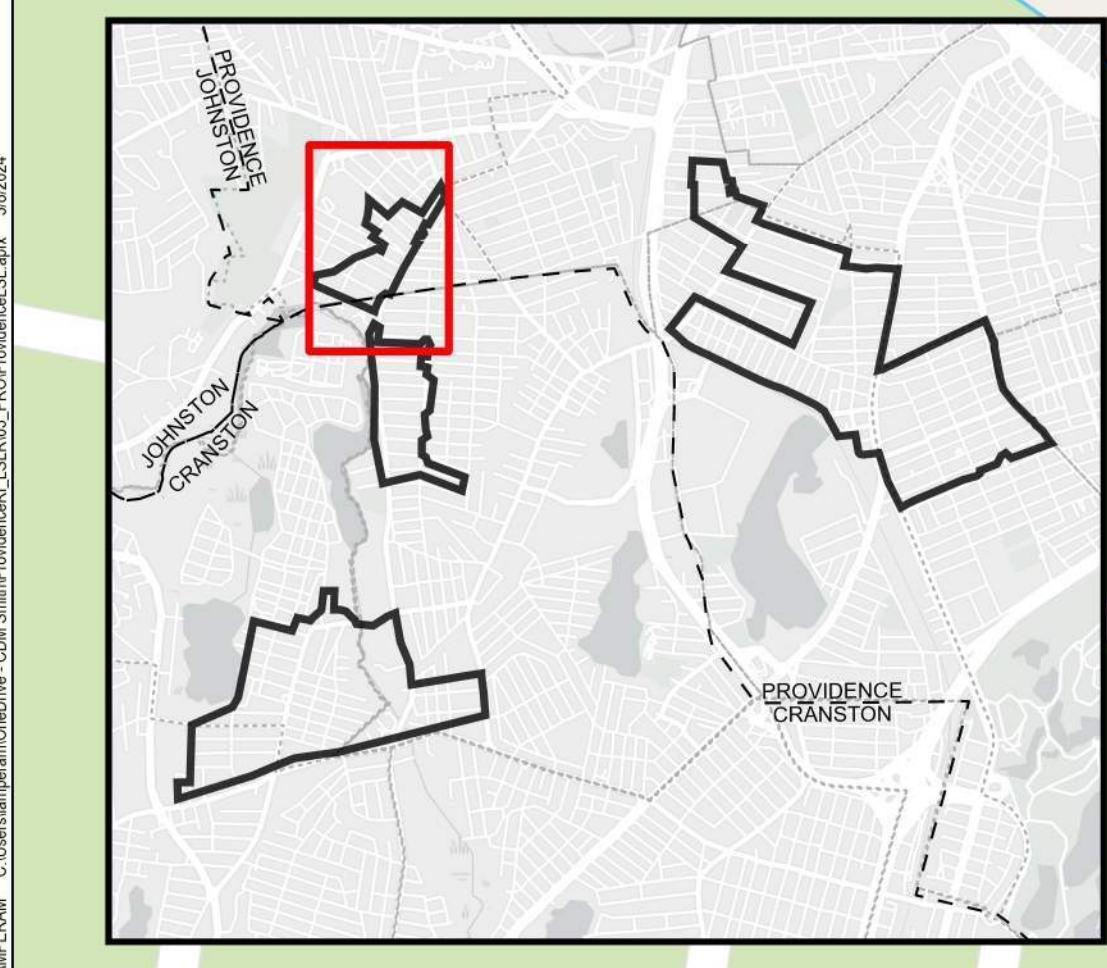



Contract 1.4 Appendix A - LSLR Locations

March 2024

Contract 1.4 Area - 4 of 4

Account Replacement Type Replacement Category ● Public Side Only ● Full ● Private Side Only — Service Line	Contract Areas Contract 1.4 Area Other Contracts Boundaries Municipal Boundary Ward Boundary	Roads Layers Paved 2021 - 2023 (Under Moratorium) Paved 2019 - 2020 (Under Moratorium)
--	---	---

Note: Scale is for topographical information only such as streets and buildings. Dots representing properties with lead service lines are not to scale and are for identifying the correct properties only. The lines represent which building and which street the service line runs between and does not show the service line alignment.

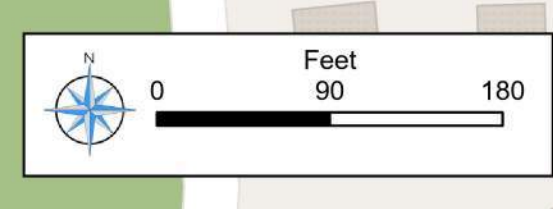

FULL ADDRESS	HOUSE NUMBER	STREET	SUFFIX	CITY	STATE	ZIPCODE	SERVICE DIAMETER	BUILDING TYPE	PUBLIC SIDE MATERIAL	PRIVATE SIDE MATERIAL	WARD	REPLACEMENT TYPE
21 ADELAIDE AVE	21	ADELAIDE	AVE	PROVIDENCE	RI	02907	1	Multi-Family	Non-Lead	Lead	9	Private Side Only
22 ADELAIDE AVE	22	ADELAIDE	AVE	PROVIDENCE	RI	02907	1	Multi-Family	Non-Lead	Lead	9	Private Side Only
198 ADELAIDE AVE	198	ADELAIDE	AVE	PROVIDENCE	RI	02907	1	Multi-Family	Non-Lead	Lead	9	Private Side Only
225 ADELAIDE AVE	225	ADELAIDE	AVE	PROVIDENCE	RI	02907	1	Single-Family	Non-Lead	Lead	9	Private Side Only
109 ADELAIDE AVE	109	ADELAIDE	AVE	PROVIDENCE	RI	02907	1	Multi-Family	Non-Lead	Lead	9	Private Side Only
238 ADELAIDE AVE	238	ADELAIDE	AVE	PROVIDENCE	RI	02907	1	Multi-Family	Non-Lead	Lead	9	Private Side Only
218 ADELAIDE AVE	218	ADELAIDE	AVE	PROVIDENCE	RI	02907	1	Multi-Family	Non-Lead	Lead	9	Private Side Only
188 ADELAIDE AVE	188	ADELAIDE	AVE	PROVIDENCE	RI	02907	1	Multi-Family	Non-Lead	Lead	9	Private Side Only
243 ADELAIDE AVE	243	ADELAIDE	AVE	PROVIDENCE	RI	02907	1	Multi-Family	Non-Lead	Lead	9	Private Side Only
48 ADELAIDE AVE	48	ADELAIDE	AVE	PROVIDENCE	RI	02907	1	Multi-Family	Non-Lead	Lead	9	Private Side Only
203 ADELAIDE AVE	203	ADELAIDE	AVE	PROVIDENCE	RI	02907	1	Multi-Family	Non-Lead	Lead	9	Private Side Only
99 ADELAIDE AVE	99	ADELAIDE	AVE	PROVIDENCE	RI	02907	1	Multi-Family	Non-Lead	Lead	9	Private Side Only
242 ADELAIDE AVE	242	ADELAIDE	AVE	PROVIDENCE	RI	02907	1	Multi-Family	Non-Lead	Lead	9	Private Side Only
222 ADELAIDE AVE	222	ADELAIDE	AVE	PROVIDENCE	RI	02907	1	Single-Family	Non-Lead	Lead	9	Private Side Only
239 ADELAIDE AVE	239	ADELAIDE	AVE	PROVIDENCE	RI	02907	1	Multi-Family	Non-Lead	Lead	9	Private Side Only
91 ADELAIDE AVE	91	ADELAIDE	AVE	PROVIDENCE	RI	02907	1	Multi-Family	Non-Lead	Lead	9	Private Side Only
40 ADELAIDE AVE	40	ADELAIDE	AVE	PROVIDENCE	RI	02907	1	Multi-Family	Non-Lead	Lead	9	Private Side Only
57 ADELAIDE AVE	57	ADELAIDE	AVE	PROVIDENCE	RI	02907	1	Multi-Family	Non-Lead	Lead	9	Private Side Only
115 ADELAIDE AVE	115	ADELAIDE	AVE	PROVIDENCE	RI	02907	1	Multi-Family	Non-Lead	Lead	9	Private Side Only
101 ADELAIDE AVE	101	ADELAIDE	AVE	PROVIDENCE	RI	02907	1	Multi-Family	Non-Lead	Lead	9	Private Side Only
200 ADELAIDE AVE	200	ADELAIDE	AVE	PROVIDENCE	RI	02907	1	Multi-Family	Non-Lead	Lead	9	Private Side Only
166 ADELAIDE AVE	166	ADELAIDE	AVE	PROVIDENCE	RI	02907	1	Multi-Family	Non-Lead	Lead	9	Private Side Only
129 ADELAIDE AVE	129	ADELAIDE	AVE	PROVIDENCE	RI	02907	1	Multi-Family	Non-Lead	Lead	9	Private Side Only
130 ADELAIDE AVE	130	ADELAIDE	AVE	PROVIDENCE	RI	02907	1	Multi-Family	Non-Lead	Lead	9	Private Side Only
194 ADELAIDE AVE	194	ADELAIDE	AVE	PROVIDENCE	RI	02907	1	Single-Family	Non-Lead	Lead	9	Private Side Only
146 ADELAIDE AVE	146	ADELAIDE	AVE	PROVIDENCE	RI	02907	0.625	Single-Family	Lead	Lead	9	Full
208 ADELAIDE AVE	208	ADELAIDE	AVE	PROVIDENCE	RI	02907	1	Multi-Family	Non-Lead	Lead	9	Private Side Only
161 ADELAIDE AVE	161	ADELAIDE	AVE	PROVIDENCE	RI	02907	1	Single-Family	Non-Lead	Lead	9	Private Side Only
14 ADELAIDE AVE	14	ADELAIDE	AVE	PROVIDENCE	RI	02907	1	Multi-Family	Non-Lead	Lead	9	Private Side Only
44 ADELAIDE AVE	44	ADELAIDE	AVE	PROVIDENCE	RI	02907	1	Multi-Family	Non-Lead	Lead	9	Private Side Only
137 ADELAIDE AVE	137	ADELAIDE	AVE	PROVIDENCE	RI	02907	1	Multi-Family	Non-Lead	Lead	9	Private Side Only
138 ADELAIDE AVE	138	ADELAIDE	AVE	PROVIDENCE	RI	02907	1	Multi-Family	Non-Lead	Lead	9	Private Side Only
210 ADELAIDE AVE	210	ADELAIDE	AVE	PROVIDENCE	RI	02907	1	Multi-Family	Non-Lead	Lead	9	Private Side Only
95 ADELAIDE AVE	95	ADELAIDE	AVE	PROVIDENCE	RI	02907	1	Multi-Family	Non-Lead	Lead	9	Private Side Only
34 ADELAIDE AVE	34	ADELAIDE	AVE	PROVIDENCE	RI	02907	1	Multi-Family	Non-Lead	Lead	9	Private Side Only
140 ADELAIDE AVE	140	ADELAIDE	AVE	PROVIDENCE	RI	02907	1	Multi-Family	Non-Lead	Lead	9	Private Side Only
232 ADELAIDE AVE	232	ADELAIDE	AVE	PROVIDENCE	RI	02907	1	Multi-Family	Non-Lead	Lead	9	Private Side Only
25 ADELAIDE AVE	25	ADELAIDE	AVE	PROVIDENCE	RI	02907	1	Multi-Family	Non-Lead	Lead	9	Private Side Only
185 ADELAIDE AVE	185	ADELAIDE	AVE	PROVIDENCE	RI	02907	1	Multi-Family	Non-Lead	Lead	9	Private Side Only
252 ADELAIDE AVE	252	ADELAIDE	AVE	PROVIDENCE	RI	02907	1	Mixed Residential & Nonresidential	Non-Lead	Lead	9	Private Side Only
64 ADELAIDE AVE	64	ADELAIDE	AVE	PROVIDENCE	RI	02907	1	Single-Family	Non-Lead	Lead	9	Private Side Only

FULL ADDRESS	HOUSE NUMBER	STREET	SUFFIX	CITY	STATE	ZIPCODE	SERVICE DIAMETER	BUILDING TYPE	PUBLIC SIDE MATERIAL	PRIVATE SIDE MATERIAL	WARD	REPLACEMENT TYPE
70 ADELAIDE AVE	70	ADELAIDE	AVE	PROVIDENCE	RI	02907	1	Single-Family	Non-Lead	Lead	9	Private Side Only
65 ADELAIDE AVE	65	ADELAIDE	AVE	PROVIDENCE	RI	02907	1	Multi-Family	Non-Lead	Lead	9	Private Side Only
12 ANTHONY AVE	12	ANTHONY	AVE	PROVIDENCE	RI	02907	0.75	Non residential	Non-Lead	Lead	8	Private Side Only
32 ANTHONY AVE	32	ANTHONY	AVE	PROVIDENCE	RI	02907	1	Single-Family	Non-Lead	Lead	8	Private Side Only
17 ANTHONY AVE	17	ANTHONY	AVE	PROVIDENCE	RI	02907	1	Single-Family	Non-Lead	Lead	8	Private Side Only
38 ANTHONY AVE	38	ANTHONY	AVE	PROVIDENCE	RI	02907	1	Multi-Family	Non-Lead	Lead	8	Private Side Only
34 ANTHONY AVE	34	ANTHONY	AVE	PROVIDENCE	RI	02907	1	Single-Family	Non-Lead	Lead	8	Private Side Only
28 ANTHONY AVE	28	ANTHONY	AVE	PROVIDENCE	RI	02907	1	Multi-Family	Non-Lead	Lead	8	Private Side Only
45 ANTHONY AVE	45	ANTHONY	AVE	PROVIDENCE	RI	02907	1	Non residential	Non-Lead	Lead	8	Private Side Only
92 ATLANTIC AVE	92	ATLANTIC	AVE	PROVIDENCE	RI	02907	1	Single-Family	Non-Lead	Lead	9	Private Side Only
93 ATLANTIC AVE	93	ATLANTIC	AVE	PROVIDENCE	RI	02907	1	Multi-Family	Non-Lead	Lead	9	Private Side Only
47 ATLANTIC AVE	47	ATLANTIC	AVE	PROVIDENCE	RI	02907	1	Multi-Family	Non-Lead	Lead	9	Private Side Only
31 ATLANTIC AVE	31	ATLANTIC	AVE	PROVIDENCE	RI	02907	1	Multi-Family	Non-Lead	Lead	9	Private Side Only
188 ATLANTIC AVE	188	ATLANTIC	AVE	PROVIDENCE	RI	02907	1	Multi-Family	Non-Lead	Lead	9	Private Side Only
229 ATLANTIC AVE	229	ATLANTIC	AVE	PROVIDENCE	RI	02907	1	Multi-Family	Non-Lead	Lead	9	Private Side Only
56 ATLANTIC AVE	56	ATLANTIC	AVE	PROVIDENCE	RI	02907	1	Multi-Family	Non-Lead	Lead	9	Private Side Only
134 ATLANTIC AVE	134	ATLANTIC	AVE	PROVIDENCE	RI	02907	1	Multi-Family	Non-Lead	Lead	9	Private Side Only
12 ATLANTIC AVE	12	ATLANTIC	AVE	PROVIDENCE	RI	02907	1	Multi-Family	Non-Lead	Lead	9	Private Side Only
126 ATLANTIC AVE	126	ATLANTIC	AVE	PROVIDENCE	RI	02907	1	Multi-Family	Non-Lead	Lead	9	Private Side Only
143 ATLANTIC AVE	143	ATLANTIC	AVE	PROVIDENCE	RI	02907	1	Multi-Family	Non-Lead	Lead	9	Private Side Only
232 ATLANTIC AVE	232	ATLANTIC	AVE	PROVIDENCE	RI	02907	1	Multi-Family	Non-Lead	Lead	9	Private Side Only
19 ATLANTIC AVE	19	ATLANTIC	AVE	PROVIDENCE	RI	02907	1	Multi-Family	Non-Lead	Lead	9	Private Side Only
211 ATLANTIC AVE	211	ATLANTIC	AVE	PROVIDENCE	RI	02907	1	Multi-Family	Non-Lead	Lead	9	Private Side Only
149 ATLANTIC AVE	149	ATLANTIC	AVE	PROVIDENCE	RI	02907	1	Multi-Family	Non-Lead	Lead	9	Private Side Only
160 ATLANTIC AVE	160	ATLANTIC	AVE	PROVIDENCE	RI	02907	1	Mixed Residential & Nonresidential	Non-Lead	Lead	9	Private Side Only
108 ATLANTIC AVE	108	ATLANTIC	AVE	PROVIDENCE	RI	02907	1	Multi-Family	Non-Lead	Lead	9	Private Side Only
86 ATLANTIC AVE	86	ATLANTIC	AVE	PROVIDENCE	RI	02907	1	Multi-Family	Non-Lead	Lead	9	Private Side Only
157 ATLANTIC AVE	157	ATLANTIC	AVE	PROVIDENCE	RI	02907	1	Multi-Family	Non-Lead	Lead	9	Private Side Only
141 ATLANTIC AVE	141	ATLANTIC	AVE	PROVIDENCE	RI	02907	1	Multi-Family	Non-Lead	Lead	9	Private Side Only
23 ATLANTIC AVE	23	ATLANTIC	AVE	PROVIDENCE	RI	02907	1	Multi-Family	Non-Lead	Lead	9	Private Side Only
50 ATLANTIC AVE	50	ATLANTIC	AVE	PROVIDENCE	RI	02907	1	Multi-Family	Non-Lead	Lead	9	Private Side Only
30 ATLANTIC AVE	30	ATLANTIC	AVE	PROVIDENCE	RI	02907	1	Multi-Family	Non-Lead	Lead	9	Private Side Only
192 ATLANTIC AVE	192	ATLANTIC	AVE	PROVIDENCE	RI	02907	1	Multi-Family	Non-Lead	Lead	9	Private Side Only
138 ATLANTIC AVE	138	ATLANTIC	AVE	PROVIDENCE	RI	02907	1	Multi-Family	Non-Lead	Lead	9	Private Side Only
122 ATLANTIC AVE	122	ATLANTIC	AVE	PROVIDENCE	RI	02907	1	Multi-Family	Non-Lead	Lead	9	Private Side Only
61 ATLANTIC AVE	61	ATLANTIC	AVE	PROVIDENCE	RI	02907	1	Multi-Family	Non-Lead	Lead	9	Private Side Only
110 ATLANTIC AVE	110	ATLANTIC	AVE	PROVIDENCE	RI	02907	1	Single-Family	Non-Lead	Lead	9	Private Side Only
230 ATLANTIC AVE	230	ATLANTIC	AVE	PROVIDENCE	RI	02907	1	Single-Family	Non-Lead	Lead	9	Private Side Only
123 ATLANTIC AVE	123	ATLANTIC	AVE	PROVIDENCE	RI	02907	1	Multi-Family	Non-Lead	Lead	9	Private Side Only
107 ATLANTIC AVE	107	ATLANTIC	AVE	PROVIDENCE	RI	02907	1	Multi-Family	Non-Lead	Lead	9	Private Side Only
15 ATLANTIC AVE	15	ATLANTIC	AVE	PROVIDENCE	RI	02907	1	Multi-Family	Non-Lead	Lead	9	Private Side Only

FULL ADDRESS	HOUSE NUMBER	STREET	SUFFIX	CITY	STATE	ZIPCODE	SERVICE DIAMETER	BUILDING TYPE	PUBLIC SIDE MATERIAL	PRIVATE SIDE MATERIAL	WARD	REPLACEMENT TYPE
139 ATLANTIC AVE	139	ATLANTIC	AVE	PROVIDENCE	RI	02907	1	Multi-Family	Non-Lead	Lead	9	Private Side Only
103 ATLANTIC AVE	103	ATLANTIC	AVE	PROVIDENCE	RI	02907	1	Single-Family	Non-Lead	Lead	9	Private Side Only
35 ATLANTIC AVE	35	ATLANTIC	AVE	PROVIDENCE	RI	02907	1	Multi-Family	Non-Lead	Lead	9	Private Side Only
51 ATLANTIC AVE	51	ATLANTIC	AVE	PROVIDENCE	RI	02907	1	Single-Family	Non-Lead	Lead	9	Private Side Only
8 ATLANTIC AVE	8	ATLANTIC	AVE	PROVIDENCE	RI	02907	1	Multi-Family	Non-Lead	Lead	9	Private Side Only
222 ATLANTIC AVE	222	ATLANTIC	AVE	PROVIDENCE	RI	02907	1	Multi-Family	Non-Lead	Lead	9	Private Side Only
34 ATLANTIC AVE	34	ATLANTIC	AVE	PROVIDENCE	RI	02907	1	Multi-Family	Non-Lead	Lead	9	Private Side Only
64 ATLANTIC AVE	64	ATLANTIC	AVE	PROVIDENCE	RI	02907	1	Single-Family	Non-Lead	Lead	9	Private Side Only
151 ATLANTIC AVE	151	ATLANTIC	AVE	PROVIDENCE	RI	02907	1	Multi-Family	Non-Lead	Lead	9	Private Side Only
74 BATCHELLER AVE	74	BATCHELLER	AVE	CRANSTON	RI	02920	1	Multi-Family	Non-Lead	Lead	5	Private Side Only
16 BATCHELLER AVE	16	BATCHELLER	AVE	CRANSTON	RI	02920	1	Single-Family	Non-Lead	Lead	5	Private Side Only
43 BATCHELLER AVE	43	BATCHELLER	AVE	CRANSTON	RI	02920	0.75	Single-Family	Non-Lead	Lead	5	Private Side Only
38 BATCHELLER AVE	38	BATCHELLER	AVE	CRANSTON	RI	02920	1	Multi-Family	Non-Lead	Lead	5	Private Side Only
42 BATCHELLER AVE	42	BATCHELLER	AVE	CRANSTON	RI	02920	1	Multi-Family	Non-Lead	Lead	5	Private Side Only
96 BELLEVUE AVE	96	BELLEVUE	AVE	PROVIDENCE	RI	02907	1	Multi-Family	Non-Lead	Lead	8	Private Side Only
164 BELLEVUE AVE	164	BELLEVUE	AVE	PROVIDENCE	RI	02907	1	Multi-Family	Non-Lead	Lead	8	Private Side Only
160 BELLEVUE AVE	160	BELLEVUE	AVE	PROVIDENCE	RI	02907	1	Multi-Family	Non-Lead	Lead	8	Private Side Only
135 BELLEVUE AVE	135	BELLEVUE	AVE	PROVIDENCE	RI	02907	1	Multi-Family	Non-Lead	Lead	8	Private Side Only
189 BELLEVUE AVE	189	BELLEVUE	AVE	PROVIDENCE	RI	02907	0.75	Multi-Family	Non-Lead	Lead	8	Private Side Only
203 BELLEVUE AVE	203	BELLEVUE	AVE	PROVIDENCE	RI	02907	1	Multi-Family	Non-Lead	Lead	8	Private Side Only
129 BELLEVUE AVE	129	BELLEVUE	AVE	PROVIDENCE	RI	02907	1	Multi-Family	Non-Lead	Lead	8	Private Side Only
132 BELLEVUE AVE	132	BELLEVUE	AVE	PROVIDENCE	RI	02907	1	Multi-Family	Non-Lead	Lead	8	Private Side Only
140 BELLEVUE AVE	140	BELLEVUE	AVE	PROVIDENCE	RI	02907	1	Multi-Family	Non-Lead	Lead	8	Private Side Only
190 BELLEVUE AVE	190	BELLEVUE	AVE	PROVIDENCE	RI	02907	1	Multi-Family	Non-Lead	Lead	8	Private Side Only
174 BELLEVUE AVE	174	BELLEVUE	AVE	PROVIDENCE	RI	02907	1	Multi-Family	Non-Lead	Lead	8	Private Side Only
187 BELLEVUE AVE	187	BELLEVUE	AVE	PROVIDENCE	RI	02907	1	Multi-Family	Non-Lead	Lead	8	Private Side Only
167 BELLEVUE AVE	167	BELLEVUE	AVE	PROVIDENCE	RI	02907	1	Multi-Family	Non-Lead	Lead	8	Private Side Only
145 BELLEVUE AVE	145	BELLEVUE	AVE	PROVIDENCE	RI	02907	1	Multi-Family	Non-Lead	Lead	8	Private Side Only
105 BELLEVUE AVE	105	BELLEVUE	AVE	PROVIDENCE	RI	02907	1	Multi-Family	Non-Lead	Lead	8	Private Side Only
195 BELLEVUE AVE	195	BELLEVUE	AVE	PROVIDENCE	RI	02907	1	Multi-Family	Non-Lead	Lead	8	Private Side Only
181 BELLEVUE AVE	181	BELLEVUE	AVE	PROVIDENCE	RI	02907	1	Multi-Family	Non-Lead	Lead	8	Private Side Only
158 BELLEVUE AVE	158	BELLEVUE	AVE	PROVIDENCE	RI	02907	1	Multi-Family	Non-Lead	Lead	8	Private Side Only
182 BELLEVUE AVE	182	BELLEVUE	AVE	PROVIDENCE	RI	02907	1	Multi-Family	Non-Lead	Lead	8	Private Side Only
89 BELLEVUE AVE	89	BELLEVUE	AVE	PROVIDENCE	RI	02907	1	Non residential	Non-Lead	Lead	8	Private Side Only
216 BELLEVUE AVE	216	BELLEVUE	AVE	PROVIDENCE	RI	02907	1	Multi-Family	Non-Lead	Lead	8	Private Side Only
125 BELLEVUE AVE	125	BELLEVUE	AVE	PROVIDENCE	RI	02907	1	Multi-Family	Non-Lead	Lead	8	Private Side Only
212 BELLEVUE AVE	212	BELLEVUE	AVE	PROVIDENCE	RI	02907	1	Multi-Family	Non-Lead	Lead	8	Private Side Only
143 BELLEVUE AVE	143	BELLEVUE	AVE	PROVIDENCE	RI	02907	1	Multi-Family	Non-Lead	Lead	8	Private Side Only
202 BELLEVUE AVE	202	BELLEVUE	AVE	PROVIDENCE	RI	02907	1	Multi-Family	Non-Lead	Lead	8	Private Side Only
111 BELLEVUE AVE	111	BELLEVUE	AVE	PROVIDENCE	RI	02907	1	Multi-Family	Non-Lead	Lead	8	Private Side Only
184 BELLEVUE AVE	184	BELLEVUE	AVE	PROVIDENCE	RI	02907	1	Multi-Family	Non-Lead	Lead	8	Private Side Only

FULL ADDRESS	HOUSE NUMBER	STREET	SUFFIX	CITY	STATE	ZIPCODE	SERVICE DIAMETER	BUILDING TYPE	PUBLIC SIDE MATERIAL	PRIVATE SIDE MATERIAL	WARD	REPLACEMENT TYPE
161 BELLEVUE AVE	161	BELLEVUE	AVE	PROVIDENCE	RI	02907	1	Non residential	Non-Lead	Lead	8	Private Side Only
219 BELLEVUE AVE	219	BELLEVUE	AVE	PROVIDENCE	RI	02907	1	Multi-Family	Non-Lead	Lead	8	Private Side Only
41 CALHOUN AVE	41	CALHOUN	AVE	PROVIDENCE	RI	02907	1	Single-Family	Non-Lead	Lead	8	Private Side Only
36 CALHOUN AVE	36	CALHOUN	AVE	PROVIDENCE	RI	02907	1	Multi-Family	Non-Lead	Lead	8	Private Side Only
139 CHAPIN AVE	139	CHAPIN	AVE	PROVIDENCE	RI	02909	1	Multi-Family	Non-Lead	Lead	15	Private Side Only
129 CHAPIN AVE	129	CHAPIN	AVE	PROVIDENCE	RI	02909	0.625	Multi-Family	Lead	Lead	15	Full
147 CHAPIN AVE	147	CHAPIN	AVE	PROVIDENCE	RI	02909	0.625	Multi-Family	Lead	Lead	15	Full
150 CHAPIN AVE	150	CHAPIN	AVE	PROVIDENCE	RI	02909	1	Multi-Family	Non-Lead	Lead	15	Private Side Only
165 CHAPIN AVE	165	CHAPIN	AVE	PROVIDENCE	RI	02909	0.75	Multi-Family	Lead	Lead	15	Full
159 CHAPIN AVE	159	CHAPIN	AVE	PROVIDENCE	RI	02909	0.625	Multi-Family	Lead	Lead	15	Full
160 CHAPIN AVE	160	CHAPIN	AVE	PROVIDENCE	RI	02909	1	Multi-Family	Non-Lead	Lead	15	Private Side Only
146 CHAPIN AVE	146	CHAPIN	AVE	PROVIDENCE	RI	02909	0.625	Multi-Family	Lead	Lead	15	Full
138 CHAPIN AVE	138	CHAPIN	AVE	PROVIDENCE	RI	02909	0.625	Multi-Family	Lead	Lead	15	Full
151 CHAPIN AVE	151	CHAPIN	AVE	PROVIDENCE	RI	02909	0.625	Single-Family	Lead	Lead	15	Full
154 CHAPIN AVE	154	CHAPIN	AVE	PROVIDENCE	RI	02909	1	Multi-Family	Non-Lead	Lead	15	Private Side Only
127 CHAPIN AVE	127	CHAPIN	AVE	PROVIDENCE	RI	02909	0.625	Multi-Family	Lead	Lead	15	Full
126 CHAPIN AVE	126	CHAPIN	AVE	PROVIDENCE	RI	02909	0.625	Multi-Family	Lead	Lead	15	Full
134 CHAPIN AVE	134	CHAPIN	AVE	PROVIDENCE	RI	02909	0.625	Multi-Family	Lead	Lead	15	Full
124 CHAPIN AVE	124	CHAPIN	AVE	PROVIDENCE	RI	02909	0.625	Multi-Family	Lead	Lead	15	Full
143 CHAPIN AVE	143	CHAPIN	AVE	PROVIDENCE	RI	02909	0.625	Multi-Family	Lead	Lead	15	Full
155 CHAPIN AVE	155	CHAPIN	AVE	PROVIDENCE	RI	02909	0.625	Multi-Family	Lead	Lead	15	Full
161 CHAPIN AVE	161	CHAPIN	AVE	PROVIDENCE	RI	02905	1	Multi-Family	Lead	Lead	15	Full
130 CHAPIN AVE	130	CHAPIN	AVE	PROVIDENCE	RI	02909	1	Multi-Family	Non-Lead	Lead	15	Private Side Only
69 CONGRESS AVE	69	CONGRESS	AVE	PROVIDENCE	RI	02907	1	Single-Family	Non-Lead	Lead	9	Private Side Only
42 CONGRESS AVE	42	CONGRESS	AVE	PROVIDENCE	RI	02907	1	Multi-Family	Non-Lead	Lead	9	Private Side Only
53 CONGRESS AVE	53	CONGRESS	AVE	PROVIDENCE	RI	02907	1	Multi-Family	Non-Lead	Lead	9	Private Side Only
165 CONGRESS AVE	165	CONGRESS	AVE	PROVIDENCE	RI	02907	1	Single-Family	Non-Lead	Lead	9	Private Side Only
68 CONGRESS AVE	68	CONGRESS	AVE	PROVIDENCE	RI	02907	1	Multi-Family	Non-Lead	Lead	9	Private Side Only
125 CONGRESS AVE	125	CONGRESS	AVE	PROVIDENCE	RI	02907	1	Single-Family	Non-Lead	Lead	9	Private Side Only
124 CONGRESS AVE	124	CONGRESS	AVE	PROVIDENCE	RI	02907	1	Multi-Family	Non-Lead	Lead	9	Private Side Only
85 CONGRESS AVE	85	CONGRESS	AVE	PROVIDENCE	RI	02907	1	Multi-Family	Non-Lead	Lead	9	Private Side Only
112 CONGRESS AVE	112	CONGRESS	AVE	PROVIDENCE	RI	02907	1	Multi-Family	Non-Lead	Lead	9	Private Side Only
193 CONGRESS AVE	193	CONGRESS	AVE	PROVIDENCE	RI	02907	1	Multi-Family	Non-Lead	Lead	9	Private Side Only
16 CONGRESS AVE	16	CONGRESS	AVE	PROVIDENCE	RI	02907	1	Multi-Family	Non-Lead	Lead	9	Private Side Only
166 CONGRESS AVE	166	CONGRESS	AVE	PROVIDENCE	RI	02907	1	Single-Family	Non-Lead	Lead	9	Private Side Only
134 CONGRESS AVE	134	CONGRESS	AVE	PROVIDENCE	RI	02907	1	Multi-Family	Non-Lead	Lead	9	Private Side Only
82 CONGRESS AVE	82	CONGRESS	AVE	PROVIDENCE	RI	02907	1	Single-Family	Non-Lead	Lead	9	Private Side Only
144 CONGRESS AVE	144	CONGRESS	AVE	PROVIDENCE	RI	02907	1	Single-Family	Non-Lead	Lead	9	Private Side Only
101 CONGRESS AVE	101	CONGRESS	AVE	PROVIDENCE	RI	02907	1	Multi-Family	Non-Lead	Lead	9	Private Side Only
175 CONGRESS AVE	175	CONGRESS	AVE	PROVIDENCE	RI	02907	1	Single-Family	Non-Lead	Lead	9	Private Side Only
209 CONGRESS AVE	209	CONGRESS	AVE	PROVIDENCE	RI	02907	1	Multi-Family	Non-Lead	Lead	9	Private Side Only

FULL ADDRESS	HOUSE NUMBER	STREET	SUFFIX	CITY	STATE	ZIPCODE	SERVICE DIAMETER	BUILDING TYPE	PUBLIC SIDE MATERIAL	PRIVATE SIDE MATERIAL	WARD	REPLACEMENT TYPE
176 CONGRESS AVE	176	CONGRESS	AVE	PROVIDENCE	RI	02907	1	Single-Family	Non-Lead	Lead	9	Private Side Only
186 CONGRESS AVE	186	CONGRESS	AVE	PROVIDENCE	RI	02907	1	Single-Family	Non-Lead	Lead	9	Private Side Only
201 CONGRESS AVE	201	CONGRESS	AVE	PROVIDENCE	RI	02907	1	Multi-Family	Non-Lead	Lead	9	Private Side Only
200 CONGRESS AVE	200	CONGRESS	AVE	PROVIDENCE	RI	02907	1	Multi-Family	Non-Lead	Lead	9	Private Side Only
149 CONGRESS AVE	149	CONGRESS	AVE	PROVIDENCE	RI	02907	1	Single-Family	Non-Lead	Lead	9	Private Side Only
108 CONGRESS AVE	108	CONGRESS	AVE	PROVIDENCE	RI	02907	1	Single-Family	Non-Lead	Lead	9	Private Side Only
123 CONGRESS AVE	123	CONGRESS	AVE	PROVIDENCE	RI	02907	1	Multi-Family	Non-Lead	Lead	9	Private Side Only
110 CONGRESS AVE	110	CONGRESS	AVE	PROVIDENCE	RI	02907	1	Single-Family	Non-Lead	Lead	9	Private Side Only
20 CONGRESS AVE	20	CONGRESS	AVE	PROVIDENCE	RI	02907	1	Multi-Family	Non-Lead	Lead	9	Private Side Only
107 CONGRESS AVE	107	CONGRESS	AVE	PROVIDENCE	RI	02907	1	Multi-Family	Non-Lead	Lead	9	Private Side Only
137 CONGRESS AVE	137	CONGRESS	AVE	PROVIDENCE	RI	02907	1	Multi-Family	Non-Lead	Lead	9	Private Side Only
26 CONGRESS AVE	26	CONGRESS	AVE	PROVIDENCE	RI	02907	1	Multi-Family	Non-Lead	Lead	9	Private Side Only
128 CONGRESS AVE	128	CONGRESS	AVE	PROVIDENCE	RI	02907	1	Multi-Family	Non-Lead	Lead	9	Private Side Only
19 CONGRESS AVE	19	CONGRESS	AVE	PROVIDENCE	RI	02907	1	Multi-Family	Non-Lead	Lead	9	Private Side Only
48 CONGRESS AVE	48	CONGRESS	AVE	PROVIDENCE	RI	02907	1	Multi-Family	Non-Lead	Lead	9	Private Side Only
102 CONGRESS AVE	102	CONGRESS	AVE	PROVIDENCE	RI	02907	1	Multi-Family	Non-Lead	Lead	9	Private Side Only
169 CONGRESS AVE	169	CONGRESS	AVE	PROVIDENCE	RI	02907	1	Multi-Family	Non-Lead	Lead	9	Private Side Only
59 CONGRESS AVE	59	CONGRESS	AVE	PROVIDENCE	RI	02907	1	Multi-Family	Non-Lead	Lead	9	Private Side Only
75 CONGRESS AVE	75	CONGRESS	AVE	PROVIDENCE	RI	02907	1	Multi-Family	Non-Lead	Lead	9	Private Side Only
140 DANIEL AVE	140	DANIEL	AVE	PROVIDENCE	RI	02909	1	Multi-Family	Non-Lead	Lead	7	Private Side Only
133 DANIEL AVE	133	DANIEL	AVE	PROVIDENCE	RI	02909	1	Multi-Family	Non-Lead	Lead	7	Private Side Only
132 DANIEL AVE	132	DANIEL	AVE	PROVIDENCE	RI	02909	1	Multi-Family	Non-Lead	Lead	7	Private Side Only
148 DANIEL AVE	148	DANIEL	AVE	PROVIDENCE	RI	02909	1	Single-Family	Non-Lead	Lead	7	Private Side Only
143 DANIEL AVE	143	DANIEL	AVE	PROVIDENCE	RI	02909	1	Single-Family	Non-Lead	Lead	7	Private Side Only
125 DANIEL AVE	125	DANIEL	AVE	PROVIDENCE	RI	02909	1	Multi-Family	Non-Lead	Lead	7	Private Side Only
438 DYER AVE	438	DYER	AVE	CRANSTON	RI	02920	0.625	Multi-Family	Lead	Lead	3	Full
534 DYER AVE	534	DYER	AVE	CRANSTON	RI	02920	0.625	Single-Family	Lead	Lead	3	Full
545 DYER AVE	545	DYER	AVE	CRANSTON	RI	02920	0.625	Multi-Family	Lead	Lead	3	Full
562 DYER AVE	562	DYER	AVE	CRANSTON	RI	02920	0.625	Multi-Family	Lead	Lead	3	Full
566 DYER AVE	566	DYER	AVE	CRANSTON	RI	02920	0.625	Multi-Family	Lead	Lead	3	Full
379 DYER AVE	379	DYER	AVE	CRANSTON	RI	02920	0.625	Multi-Family	Lead	Lead	3	Full
589 DYER AVE	589	DYER	AVE	CRANSTON	RI	02920	0.625	Multi-Family	Lead	Lead	3	Full
592 DYER AVE	592	DYER	AVE	CRANSTON	RI	02920	0.625	Multi-Family	Lead	Lead	3	Full
556 DYER AVE	556	DYER	AVE	CRANSTON	RI	02920	0.625	Single-Family	Lead	Lead	3	Full
539 DYER AVE	539	DYER	AVE	CRANSTON	RI	02920	0.625	Non residential	Lead	Lead	3	Full
532 DYER AVE	532	DYER	AVE	CRANSTON	RI	02920	0.625	Single-Family	Lead	Lead	3	Full
484 ELMWOOD AVE	484	ELMWOOD	AVE	PROVIDENCE	RI	02907	1	Non residential	Non-Lead	Lead	9	Private Side Only
602 ELMWOOD AVE	602	ELMWOOD	AVE	PROVIDENCE	RI	02907	1	Mixed Residential & Nonresidential	Non-Lead	Lead	9	Private Side Only
572 ELMWOOD AVE	572	ELMWOOD	AVE	PROVIDENCE	RI	02907	1	Single-Family	Non-Lead	Lead	9	Private Side Only
457 ELMWOOD AVE	457	ELMWOOD	AVE	PROVIDENCE	RI	02907	1.25	Multi-Family	Non-Lead	Lead	8	Private Side Only
560 ELMWOOD AVE	560	ELMWOOD	AVE	PROVIDENCE	RI	02907	1	Non residential	Non-Lead	Lead	9	Private Side Only

FULL ADDRESS	HOUSE NUMBER	STREET	SUFFIX	CITY	STATE	ZIPCODE	SERVICE DIAMETER	BUILDING TYPE	PUBLIC SIDE MATERIAL	PRIVATE SIDE MATERIAL	WARD	REPLACEMENT TYPE
265 ELMWOOD AVE	265	ELMWOOD	AVE	PROVIDENCE	RI	02907	0.625	Multi-Family	Lead	Lead	8	Full
122 FARMINGTON AVE	122	FARMINGTON	AVE	PROVIDENCE	RI	02909	0.75	Multi-Family	Lead	Lead	7	Full
68 FARMINGTON AVE	68	FARMINGTON	AVE	PROVIDENCE	RI	02909	1.25	Single-Family	Lead	Lead	7	Full
62 FARMINGTON AVE	62	FARMINGTON	AVE	PROVIDENCE	RI	02909	0.625	Non residential	Lead	Lead	7	Full
66 FARMINGTON AVE	66	FARMINGTON	AVE	PROVIDENCE	RI	02909	0.625	Multi-Family	Lead	Lead	7	Full
70 FARMINGTON AVE	70	FARMINGTON	AVE	PROVIDENCE	RI	02909	0.625	Single-Family	Lead	Lead	7	Full
100 FARMINGTON AVE	100	FARMINGTON	AVE	PROVIDENCE	RI	02909	0.75	Multi-Family	Lead	Lead	7	Full
83 FARMINGTON AVE	83	FARMINGTON	AVE	PROVIDENCE	RI	02909	0.625	Single-Family	Lead	Lead	7	Full
60 FARMINGTON AVE	60	FARMINGTON	AVE	PROVIDENCE	RI	02909	0.625	Single-Family	Lead	Lead	7	Full
121 FARMINGTON AVE	121	FARMINGTON	AVE	CRANSTON	RI	02909	0.625	Multi-Family	Lead	Lead	3	Full
87 FARMINGTON AVE	87	FARMINGTON	AVE	PROVIDENCE	RI	02909	0.625	Multi-Family	Lead	Lead	7	Full
114 FARMINGTON AVE	114	FARMINGTON	AVE	PROVIDENCE	RI	02909	0.625	Multi-Family	Lead	Lead	7	Full
38 FLORIDA AVE	38	FLORIDA	AVE	CRANSTON	RI	02920	1	Single-Family	Non-Lead	Lead	5	Private Side Only
19 FLORIDA AVE	19	FLORIDA	AVE	CRANSTON	RI	02920	0.625	Multi-Family	Lead	Lead	5	Full
84 FLORIDA AVE	84	FLORIDA	AVE	CRANSTON	RI	02920	0.625	Single-Family	Lead	Lead	5	Full
20 FLORIDA AVE	20	FLORIDA	AVE	CRANSTON	RI	02920	0.625	Multi-Family	Lead	Lead	5	Full
70 FLORIDA AVE	70	FLORIDA	AVE	CRANSTON	RI	02920	0.625	Multi-Family	Lead	Lead	5	Full
18 FLORIDA AVE	18	FLORIDA	AVE	CRANSTON	RI	02920	0.625	Multi-Family	Lead	Lead	5	Full
72 FLORIDA AVE	72	FLORIDA	AVE	CRANSTON	RI	02920	0.625	Single-Family	Lead	Lead	5	Full
78 FLORIDA AVE	78	FLORIDA	AVE	CRANSTON	RI	02920	0.625	Multi-Family	Lead	Lead	5	Full
17 FLORIDA AVE	17	FLORIDA	AVE	CRANSTON	RI	02920	0.625	Multi-Family	Lead	Lead	5	Full
29 FLORIDA AVE	29	FLORIDA	AVE	CRANSTON	RI	02920	0.625	Single-Family	Lead	Non-Lead	5	Public Side Only
23 FLORIDA AVE	23	FLORIDA	AVE	CRANSTON	RI	02920	0.625	Single-Family	Lead	Lead	5	Full
46 GREENE AVE	46	GREENE	AVE	CRANSTON	RI	02920	0.625	Single-Family	Lead	Lead	5	Full
52 GREENE AVE	52	GREENE	AVE	CRANSTON	RI	02920	0.625	Multi-Family	Lead	Lead	5	Full
30 GREENE AVE	30	GREENE	AVE	CRANSTON	RI	02920	0.625	Single-Family	Lead	Lead	5	Full
44 GREENE AVE	44	GREENE	AVE	CRANSTON	RI	02920	0.625	Multi-Family	Lead	Lead	5	Full
72 GREENE AVE	72	GREENE	AVE	CRANSTON	RI	02920	0.625	Multi-Family	Lead	Lead	5	Full
18 GREENE AVE	18	GREENE	AVE	CRANSTON	RI	02920	0.625	Single-Family	Lead	Lead	5	Full
5 HAVEN AVE	5	HAVEN	AVE	CRANSTON	RI	02920	0.625	Non residential	Lead	Lead	5	Full
26 HAVEN AVE	26	HAVEN	AVE	CRANSTON	RI	02920	0.625	Multi-Family	Lead	Lead	5	Full
30 HAVEN AVE	30	HAVEN	AVE	CRANSTON	RI	02920	0.625	Multi-Family	Lead	Lead	5	Full
27 HAVEN AVE	27	HAVEN	AVE	CRANSTON	RI	02920	0.625	Multi-Family	Lead	Lead	5	Full
41 HOMESTEAD AVE	41	HOMESTEAD	AVE	PROVIDENCE	RI	02907	1	Multi-Family	Non-Lead	Lead	8	Private Side Only
40 HOMESTEAD AVE	40	HOMESTEAD	AVE	PROVIDENCE	RI	02907	1	Single-Family	Non-Lead	Lead	8	Private Side Only
480 HUNTINGTON AVE	480	HUNTINGTON	AVE	PROVIDENCE	RI	02907	0.625	Multi-Family	Lead	Lead	8	Full
648 HUNTINGTON AVE	648	HUNTINGTON	AVE	PROVIDENCE	RI	02907	1	Multi-Family	Non-Lead	Lead	8	Private Side Only
484 HUNTINGTON AVE	484	HUNTINGTON	AVE	PROVIDENCE	RI	02907	1	Multi-Family	Non-Lead	Lead	8	Private Side Only
496 HUNTINGTON AVE	496	HUNTINGTON	AVE	PROVIDENCE	RI	02907	1	Single-Family	Non-Lead	Lead	8	Private Side Only
620 HUNTINGTON AVE	620	HUNTINGTON	AVE	PROVIDENCE	RI	02907	1	Non residential	Non-Lead	Lead	8	Private Side Only
690 HUNTINGTON AVE	690	HUNTINGTON	AVE	PROVIDENCE	RI	02907	1	Single-Family	Non-Lead	Lead	8	Private Side Only

FULL ADDRESS	HOUSE NUMBER	STREET	SUFFIX	CITY	STATE	ZIPCODE	SERVICE DIAMETER	BUILDING TYPE	PUBLIC SIDE MATERIAL	PRIVATE SIDE MATERIAL	WARD	REPLACEMENT TYPE
632 HUNTINGTON AVE	632	HUNTINGTON	AVE	PROVIDENCE	RI	02907	1	Single-Family	Non-Lead	Lead	8	Private Side Only
630 HUNTINGTON AVE	630	HUNTINGTON	AVE	PROVIDENCE	RI	02907	1	Single-Family	Non-Lead	Lead	8	Private Side Only
112 KINGWOOD AVE	112	KINGWOOD	AVE	CRANSTON	RI	02920	0.625	Single-Family	Lead	Lead	5	Full
120 KINGWOOD AVE	120	KINGWOOD	AVE	CRANSTON	RI	02920	0.625	Single-Family	Lead	Lead	5	Full
128 KINGWOOD AVE	128	KINGWOOD	AVE	CRANSTON	RI	02920	0.625	Single-Family	Lead	Lead	5	Full
119 KINGWOOD AVE	119	KINGWOOD	AVE	CRANSTON	RI	02920	0.625	Single-Family	Lead	Lead	5	Full
93 LEXINGTON AVE	93	LEXINGTON	AVE	PROVIDENCE	RI	02907	1	Multi-Family	Non-Lead	Lead	9	Private Side Only
108 LEXINGTON AVE	108	LEXINGTON	AVE	PROVIDENCE	RI	02907	1	Multi-Family	Non-Lead	Lead	9	Private Side Only
203 LEXINGTON AVE	203	LEXINGTON	AVE	PROVIDENCE	RI	02907	1	Single-Family	Non-Lead	Lead	9	Private Side Only
207 LEXINGTON AVE	207	LEXINGTON	AVE	PROVIDENCE	RI	02907	1	Single-Family	Non-Lead	Lead	9	Private Side Only
90 LEXINGTON AVE	90	LEXINGTON	AVE	PROVIDENCE	RI	02907	1	Multi-Family	Non-Lead	Lead	9	Private Side Only
150 LEXINGTON AVE	150	LEXINGTON	AVE	PROVIDENCE	RI	02907	0.75	Single-Family	Non-Lead	Lead	9	Private Side Only
134 LEXINGTON AVE	134	LEXINGTON	AVE	PROVIDENCE	RI	02907	1	Multi-Family	Non-Lead	Lead	9	Private Side Only
71 LEXINGTON AVE	71	LEXINGTON	AVE	PROVIDENCE	RI	02907	1	Multi-Family	Non-Lead	Lead	9	Private Side Only
213 LEXINGTON AVE	213	LEXINGTON	AVE	PROVIDENCE	RI	02907	1	Single-Family	Non-Lead	Lead	9	Private Side Only
155 LEXINGTON AVE	155	LEXINGTON	AVE	PROVIDENCE	RI	02907	1	Single-Family	Non-Lead	Lead	9	Private Side Only
202 LEXINGTON AVE	202	LEXINGTON	AVE	PROVIDENCE	RI	02907	1	Multi-Family	Non-Lead	Lead	9	Private Side Only
131 LEXINGTON AVE	131	LEXINGTON	AVE	PROVIDENCE	RI	02907	1	Single-Family	Non-Lead	Lead	9	Private Side Only
220 LEXINGTON AVE	220	LEXINGTON	AVE	PROVIDENCE	RI	02907	1	Single-Family	Non-Lead	Lead	9	Private Side Only
126 LEXINGTON AVE	126	LEXINGTON	AVE	PROVIDENCE	RI	02907	1	Multi-Family	Non-Lead	Lead	9	Private Side Only
144 LEXINGTON AVE	144	LEXINGTON	AVE	PROVIDENCE	RI	02907	1	Single-Family	Non-Lead	Lead	9	Private Side Only
94 LEXINGTON AVE	94	LEXINGTON	AVE	PROVIDENCE	RI	02907	1	Multi-Family	Non-Lead	Lead	9	Private Side Only
177 LEXINGTON AVE	177	LEXINGTON	AVE	PROVIDENCE	RI	02907	1	Multi-Family	Non-Lead	Lead	9	Private Side Only
129 LEXINGTON AVE	129	LEXINGTON	AVE	PROVIDENCE	RI	02907	1	Single-Family	Non-Lead	Lead	9	Private Side Only
204 LEXINGTON AVE	204	LEXINGTON	AVE	PROVIDENCE	RI	02907	1	Multi-Family	Non-Lead	Lead	9	Private Side Only
121 LEXINGTON AVE	121	LEXINGTON	AVE	PROVIDENCE	RI	02907	1	Multi-Family	Non-Lead	Lead	9	Private Side Only
139 LEXINGTON AVE	139	LEXINGTON	AVE	PROVIDENCE	RI	02907	1	Single-Family	Non-Lead	Lead	9	Private Side Only
133 LEXINGTON AVE	133	LEXINGTON	AVE	PROVIDENCE	RI	02907	1	Multi-Family	Non-Lead	Lead	9	Private Side Only
78 LEXINGTON AVE	78	LEXINGTON	AVE	PROVIDENCE	RI	02907	1	Multi-Family	Non-Lead	Lead	9	Private Side Only
186 LEXINGTON AVE	186	LEXINGTON	AVE	PROVIDENCE	RI	02907	1	Single-Family	Non-Lead	Lead	9	Private Side Only
84 LEXINGTON AVE	84	LEXINGTON	AVE	PROVIDENCE	RI	02907	1	Multi-Family	Non-Lead	Lead	9	Private Side Only
116 LEXINGTON AVE	116	LEXINGTON	AVE	PROVIDENCE	RI	02907	1	Multi-Family	Non-Lead	Lead	9	Private Side Only
99 LEXINGTON AVE	99	LEXINGTON	AVE	PROVIDENCE	RI	02907	1	Multi-Family	Non-Lead	Lead	9	Private Side Only
183 LEXINGTON AVE	183	LEXINGTON	AVE	PROVIDENCE	RI	02907	1	Single-Family	Non-Lead	Lead	9	Private Side Only
102 LEXINGTON AVE	102	LEXINGTON	AVE	PROVIDENCE	RI	02907	1	Multi-Family	Non-Lead	Lead	9	Private Side Only
86 LEXINGTON AVE	86	LEXINGTON	AVE	PROVIDENCE	RI	02907	1	Multi-Family	Non-Lead	Lead	9	Private Side Only
74 LEXINGTON AVE	74	LEXINGTON	AVE	PROVIDENCE	RI	02907	1	Multi-Family	Non-Lead	Lead	9	Private Side Only
75 LEXINGTON AVE	75	LEXINGTON	AVE	PROVIDENCE	RI	02907	1	Multi-Family	Non-Lead	Lead	9	Private Side Only
173 LEXINGTON AVE	173	LEXINGTON	AVE	PROVIDENCE	RI	02907	1	Single-Family	Non-Lead	Lead	9	Private Side Only
127 LEXINGTON AVE	127	LEXINGTON	AVE	PROVIDENCE	RI	02907	1	Multi-Family	Non-Lead	Lead	9	Private Side Only
199 LEXINGTON AVE	199	LEXINGTON	AVE	PROVIDENCE	RI	02907	1	Single-Family	Non-Lead	Lead	9	Private Side Only

FULL ADDRESS	HOUSE NUMBER	STREET	SUFFIX	CITY	STATE	ZIPCODE	SERVICE DIAMETER	BUILDING TYPE	PUBLIC SIDE MATERIAL	PRIVATE SIDE MATERIAL	WARD	REPLACEMENT TYPE
194 LINWOOD AVE	194	LINWOOD	AVE	PROVIDENCE	RI	02907	0.625	Multi-Family	Lead	Lead	8	Full
216 LINWOOD AVE	216	LINWOOD	AVE	PROVIDENCE	RI	02907	0.75	Multi-Family	Lead	Lead	8	Full
138 LINWOOD AVE	138	LINWOOD	AVE	PROVIDENCE	RI	02907	0.625	Multi-Family	Lead	Lead	8	Full
134 LINWOOD AVE	134	LINWOOD	AVE	PROVIDENCE	RI	02907	0.625	Single-Family	Lead	Lead	8	Full
186 LINWOOD AVE	186	LINWOOD	AVE	PROVIDENCE	RI	02907	0.625	Single-Family	Lead	Lead	8	Full
150 LINWOOD AVE	150	LINWOOD	AVE	PROVIDENCE	RI	02907	0.625	Multi-Family	Lead	Lead	8	Full
221 LINWOOD AVE	221	LINWOOD	AVE	PROVIDENCE	RI	02907	0.625	Multi-Family	Lead	Lead	8	Full
211 LINWOOD AVE	211	LINWOOD	AVE	PROVIDENCE	RI	02907	0.625	Single-Family	Lead	Lead	8	Full
177 LINWOOD AVE	177	LINWOOD	AVE	PROVIDENCE	RI	02907	0.625	Multi-Family	Lead	Lead	8	Full
204 LINWOOD AVE	204	LINWOOD	AVE	PROVIDENCE	RI	02907	0.625	Single-Family	Lead	Lead	8	Full
147 LINWOOD AVE	147	LINWOOD	AVE	PROVIDENCE	RI	02907	0.625	Single-Family	Lead	Lead	8	Full
142 LINWOOD AVE	142	LINWOOD	AVE	PROVIDENCE	RI	02907	0.75	Multi-Family	Lead	Lead	8	Full
205 LINWOOD AVE	205	LINWOOD	AVE	PROVIDENCE	RI	02907	0.75	Multi-Family	Lead	Lead	8	Full
158 LINWOOD AVE	158	LINWOOD	AVE	PROVIDENCE	RI	02907	0.75	Multi-Family	Lead	Lead	8	Full
183 LINWOOD AVE	183	LINWOOD	AVE	PROVIDENCE	RI	02907	0.625	Multi-Family	Lead	Lead	8	Full
163 LINWOOD AVE	163	LINWOOD	AVE	PROVIDENCE	RI	02907	0.625	Multi-Family	Lead	Lead	8	Full
167 LINWOOD AVE	167	LINWOOD	AVE	PROVIDENCE	RI	02907	0.75	Multi-Family	Lead	Lead	8	Full
171 LINWOOD AVE	171	LINWOOD	AVE	PROVIDENCE	RI	02907		1 Multi-Family	Non-Lead	Lead	8	Private Side Only
191 LINWOOD AVE	191	LINWOOD	AVE	PROVIDENCE	RI	02907	0.625	Single-Family	Lead	Lead	8	Full
196 LINWOOD AVE	196	LINWOOD	AVE	PROVIDENCE	RI	02907	0.625	Multi-Family	Lead	Lead	8	Full
223 LINWOOD AVE	223	LINWOOD	AVE	PROVIDENCE	RI	02907	0.625	Multi-Family	Lead	Lead	8	Full
198 LINWOOD AVE	198	LINWOOD	AVE	PROVIDENCE	RI	02907	0.625	Multi-Family	Lead	Lead	8	Full
143 LINWOOD AVE	143	LINWOOD	AVE	PROVIDENCE	RI	02907	0.625	Multi-Family	Lead	Lead	8	Full
159 LINWOOD AVE	159	LINWOOD	AVE	PROVIDENCE	RI	02907	0.75	Multi-Family	Lead	Lead	8	Full
184 LINWOOD AVE	184	LINWOOD	AVE	PROVIDENCE	RI	02907	0.625	Multi-Family	Lead	Lead	8	Full
141 LINWOOD AVE	141	LINWOOD	AVE	PROVIDENCE	RI	02907	0.625	Multi-Family	Lead	Lead	8	Full
164 LINWOOD AVE	164	LINWOOD	AVE	PROVIDENCE	RI	02907	0.625	Single-Family	Lead	Lead	8	Full
129 LINWOOD AVE	129	LINWOOD	AVE	PROVIDENCE	RI	02907	0.625	Multi-Family	Lead	Lead	8	Full
209 LINWOOD AVE	209	LINWOOD	AVE	PROVIDENCE	RI	02907	0.625	Multi-Family	Lead	Lead	8	Full
155 LINWOOD AVE	155	LINWOOD	AVE	PROVIDENCE	RI	02907	0.625	Multi-Family	Lead	Lead	8	Full
152 LINWOOD AVE	152	LINWOOD	AVE	PROVIDENCE	RI	02907		1 Single-Family	Non-Lead	Lead	8	Private Side Only
148 LINWOOD AVE	148	LINWOOD	AVE	PROVIDENCE	RI	02907	1.5	Multi-Family	Non-Lead	Lead	8	Private Side Only
190 LINWOOD AVE	190	LINWOOD	AVE	PROVIDENCE	RI	02907	0.625	Multi-Family	Lead	Lead	8	Full
208 LINWOOD AVE	208	LINWOOD	AVE	PROVIDENCE	RI	02907	0.625	Multi-Family	Lead	Lead	8	Full
135 LINWOOD AVE	135	LINWOOD	AVE	PROVIDENCE	RI	02907		1 Multi-Family	Lead	Lead	8	Full
213 LINWOOD AVE	213	LINWOOD	AVE	PROVIDENCE	RI	02907	0.625	Multi-Family	Lead	Lead	8	Full
187 LINWOOD AVE	187	LINWOOD	AVE	PROVIDENCE	RI	02907	0.625	Multi-Family	Lead	Lead	8	Full
176 LINWOOD AVE	176	LINWOOD	AVE	PROVIDENCE	RI	02907	0.625	Multi-Family	Lead	Lead	8	Full
199 LINWOOD AVE	199	LINWOOD	AVE	PROVIDENCE	RI	02907	0.625	Single-Family	Lead	Lead	8	Full
195 LINWOOD AVE	195	LINWOOD	AVE	PROVIDENCE	RI	02907	0.625	Single-Family	Lead	Lead	8	Full
162 LINWOOD AVE	162	LINWOOD	AVE	PROVIDENCE	RI	02907		1 Multi-Family	Non-Lead	Lead	8	Private Side Only

FULL ADDRESS	HOUSE NUMBER	STREET	SUFFIX	CITY	STATE	ZIPCODE	SERVICE DIAMETER	BUILDING TYPE	PUBLIC SIDE MATERIAL	PRIVATE SIDE MATERIAL	WARD	REPLACEMENT TYPE
153 LINWOOD AVE	153	LINWOOD	AVE	PROVIDENCE	RI	02907	0.625	Single-Family	Lead	Lead	8	Full
168 LINWOOD AVE	168	LINWOOD	AVE	PROVIDENCE	RI	02907	0.625	Multi-Family	Lead	Lead	8	Full
212 LINWOOD AVE	212	LINWOOD	AVE	PROVIDENCE	RI	02907	0.625	Multi-Family	Lead	Lead	8	Full
172 LINWOOD AVE	172	LINWOOD	AVE	PROVIDENCE	RI	02907	1	Single-Family	Non-Lead	Lead	8	Private Side Only
23 MATHEWSON AVE	23	MATHEWSON	AVE	CRANSTON	RI	02920	0.625	Multi-Family	Lead	Lead	5	Full
12 NINIGRET AVE	12	NINIGRET	AVE	PROVIDENCE	RI	02907	1	Single-Family	Non-Lead	Lead	8	Private Side Only
48 NINIGRET AVE	48	NINIGRET	AVE	PROVIDENCE	RI	02907	1	Single-Family	Non-Lead	Lead	8	Private Side Only
39 NINIGRET AVE	39	NINIGRET	AVE	PROVIDENCE	RI	02907	1	Single-Family	Non-Lead	Lead	8	Private Side Only
42 NINIGRET AVE	42	NINIGRET	AVE	PROVIDENCE	RI	02907	1	Multi-Family	Non-Lead	Lead	8	Private Side Only
54 NINIGRET AVE	54	NINIGRET	AVE	PROVIDENCE	RI	02907	1	Single-Family	Non-Lead	Lead	8	Private Side Only
20 NINIGRET AVE	20	NINIGRET	AVE	PROVIDENCE	RI	02907	1	Multi-Family	Non-Lead	Lead	8	Private Side Only
24 NINIGRET AVE	24	NINIGRET	AVE	PROVIDENCE	RI	02907	1	Multi-Family	Non-Lead	Lead	8	Private Side Only
10 NINIGRET AVE	10	NINIGRET	AVE	PROVIDENCE	RI	02907	1	Multi-Family	Non-Lead	Lead	8	Private Side Only
14 NOYES AVE	14	NOYES	AVE	PROVIDENCE	RI	02907	1	Multi-Family	Non-Lead	Lead	8	Private Side Only
15 NOYES AVE	15	NOYES	AVE	PROVIDENCE	RI	02907	1	Multi-Family	Non-Lead	Lead	8	Private Side Only
43 NOYES AVE	43	NOYES	AVE	PROVIDENCE	RI	02907	1	Single-Family	Non-Lead	Lead	8	Private Side Only
21 NOYES AVE	21	NOYES	AVE	PROVIDENCE	RI	02907	1	Multi-Family	Non-Lead	Lead	8	Private Side Only
10 NOYES AVE	10	NOYES	AVE	PROVIDENCE	RI	02907	1	Multi-Family	Non-Lead	Lead	8	Private Side Only
185 POCASSET AVE	185	POCASSET	AVE	PROVIDENCE	RI	02909	0.625	Non residential	Lead	Lead	7	Full
254 POCASSET AVE	254	POCASSET	AVE	PROVIDENCE	RI	02909	0.625	Mixed Residential & Nonresidential	Lead	Lead	7	Full
311 POCASSET AVE	311	POCASSET	AVE	PROVIDENCE	RI	02909	0.625	Non residential	Lead	Lead	7	Full
234 POCASSET AVE	234	POCASSET	AVE	PROVIDENCE	RI	02909	0.625	Mixed Residential & Nonresidential	Lead	Lead	7	Full
192 POCASSET AVE	192	POCASSET	AVE	PROVIDENCE	RI	02909	0.75	Multi-Family	Non-Lead	Lead	7	Private Side Only
172 POCASSET AVE	172	POCASSET	AVE	PROVIDENCE	RI	02909	0.625	Multi-Family	Lead	Lead	7	Full
299 POCASSET AVE	299	POCASSET	AVE	PROVIDENCE	RI	02909	1	Non residential	Lead	Lead	7	Full
328 POCASSET AVE	328	POCASSET	AVE	PROVIDENCE	RI	02908	1	Mixed Residential & Nonresidential	Non-Lead	Lead	7	Private Side Only
261 POCASSET AVE	261	POCASSET	AVE	PROVIDENCE	RI	02909	0.75	Non residential	Lead	Lead	7	Full
275 POCASSET AVE	275	POCASSET	AVE	PROVIDENCE	RI	02909	1	Non residential	Lead	Lead	7	Full
214 POCASSET AVE	214	POCASSET	AVE	PROVIDENCE	RI	02909	0.625	Non residential	Lead	Lead	7	Full
297 POCASSET AVE	297	POCASSET	AVE	PROVIDENCE	RI	02909	0.625	Mixed Residential & Nonresidential	Lead	Lead	7	Full
173 POCASSET AVE	173	POCASSET	AVE	PROVIDENCE	RI	02909	1	Multi-Family	Non-Lead	Lead	7	Private Side Only
251 POCASSET AVE	251	POCASSET	AVE	PROVIDENCE	RI	02909	0.625	Multi-Family	Lead	Lead	7	Full
179 POCASSET AVE	179	POCASSET	AVE	PROVIDENCE	RI	02909	0.625	Multi-Family	Lead	Lead	7	Full
207 POCASSET AVE	207	POCASSET	AVE	PROVIDENCE	RI	02909	0.625	Mixed Residential & Nonresidential	Lead	Non-Lead	7	Public Side Only
180 POCASSET AVE	180	POCASSET	AVE	PROVIDENCE	RI	02909	0.625	Non residential	Lead	Lead	7	Full
276 POCASSET AVE	276	POCASSET	AVE	PROVIDENCE	RI	02909	0.625	Non residential	Lead	Lead	7	Full
302 POCASSET AVE	302	POCASSET	AVE	PROVIDENCE	RI	02909	0.625	Mixed Residential & Nonresidential	Lead	Lead	7	Full
291 POCASSET AVE	291	POCASSET	AVE	PROVIDENCE	RI	02909	0.625	Multi-Family	Lead	Lead	7	Full
215 POCASSET AVE	215	POCASSET	AVE	PROVIDENCE	RI	02909	1	Multi-Family	Non-Lead	Lead	7	Private Side Only
247 POCASSET AVE	247	POCASSET	AVE	PROVIDENCE	RI	02909	0.625	Mixed Residential & Nonresidential	Lead	Lead	7	Full
163 POCASSET AVE	163	POCASSET	AVE	PROVIDENCE	RI	02909	0.625	Non residential	Lead	Lead	7	Full

FULL ADDRESS	HOUSE NUMBER	STREET	SUFFIX	CITY	STATE	ZIPCODE	SERVICE DIAMETER	BUILDING TYPE	PUBLIC SIDE MATERIAL	PRIVATE SIDE MATERIAL	WARD	REPLACEMENT TYPE
202 POCASSET AVE	202	POCASSET	AVE	PROVIDENCE	RI	02909	0.625	Multi-Family	Lead	Lead	7	Full
265 POCASSET AVE	265	POCASSET	AVE	PROVIDENCE	RI	02909	0.625	Mixed Residential & Nonresidential	Lead	Non-Lead	7	Public Side Only
292 POCASSET AVE	292	POCASSET	AVE	PROVIDENCE	RI	02909	0.625	Mixed Residential & Nonresidential	Lead	Lead	7	Full
208 POCASSET AVE	208	POCASSET	AVE	PROVIDENCE	RI	02909	0.625	Multi-Family	Lead	Lead	7	Full
167 POCASSET AVE	167	POCASSET	AVE	PROVIDENCE	RI	02909	0.625	Multi-Family	Lead	Lead	7	Full
188 POCASSET AVE	188	POCASSET	AVE	PROVIDENCE	RI	02909	0.625	Multi-Family	Lead	Lead	7	Full
572 POTTERS AVE	572	POTTERS	AVE	PROVIDENCE	RI	02907	1	Multi-Family	Non-Lead	Lead	8	Private Side Only
411 POTTERS AVE	411	POTTERS	AVE	PROVIDENCE	RI	02907	1	Single-Family	Non-Lead	Lead	9	Private Side Only
808 POTTERS AVE	808	POTTERS	AVE	PROVIDENCE	RI	02907	1	Multi-Family	Non-Lead	Lead	8	Private Side Only
750 POTTERS AVE	750	POTTERS	AVE	PROVIDENCE	RI	02907	1	Non residential	Non-Lead	Lead	8	Private Side Only
455 POTTERS AVE	455	POTTERS	AVE	PROVIDENCE	RI	02907	1	Multi-Family	Non-Lead	Lead	9	Private Side Only
721 POTTERS AVE	721	POTTERS	AVE	PROVIDENCE	RI	02907	1	Multi-Family	Non-Lead	Lead	8	Private Side Only
709 POTTERS AVE	709	POTTERS	AVE	PROVIDENCE	RI	02907	1	Multi-Family	Non-Lead	Lead	8	Private Side Only
680 POTTERS AVE	680	POTTERS	AVE	PROVIDENCE	RI	02907	1	Mixed Residential & Nonresidential	Non-Lead	Lead	8	Private Side Only
501 POTTERS AVE	501	POTTERS	AVE	PROVIDENCE	RI	02907	1	Multi-Family	Non-Lead	Lead	9	Private Side Only
558 POTTERS AVE	558	POTTERS	AVE	PROVIDENCE	RI	02907	1	Multi-Family	Non-Lead	Lead	8	Private Side Only
623 POTTERS AVE	623	POTTERS	AVE	PROVIDENCE	RI	02907	1	Multi-Family	Non-Lead	Lead	8	Private Side Only
542 POTTERS AVE	542	POTTERS	AVE	PROVIDENCE	RI	02907	1	Non residential	Non-Lead	Lead	8	Private Side Only
505 POTTERS AVE	505	POTTERS	AVE	PROVIDENCE	RI	02907	1	Single-Family	Non-Lead	Lead	9	Private Side Only
441 POTTERS AVE	441	POTTERS	AVE	PROVIDENCE	RI	02907	1	Multi-Family	Non-Lead	Lead	9	Private Side Only
552 POTTERS AVE	552	POTTERS	AVE	PROVIDENCE	RI	02907	1	Single-Family	Non-Lead	Lead	8	Private Side Only
598 POTTERS AVE	598	POTTERS	AVE	PROVIDENCE	RI	02907	1	Multi-Family	Non-Lead	Lead	8	Private Side Only
565 POTTERS AVE	565	POTTERS	AVE	PROVIDENCE	RI	02907	1	Multi-Family	Non-Lead	Lead	8	Private Side Only
715 POTTERS AVE	715	POTTERS	AVE	PROVIDENCE	RI	02907	0.75	Multi-Family	Lead	Lead	8	Full
353 POTTERS AVE	353	POTTERS	AVE	PROVIDENCE	RI	02907	1	Multi-Family	Non-Lead	Lead	9	Private Side Only
354 POTTERS AVE	354	POTTERS	AVE	PROVIDENCE	RI	02907	1	Multi-Family	Non-Lead	Lead	9	Private Side Only
473 POTTERS AVE	473	POTTERS	AVE	PROVIDENCE	RI	02907	1	Multi-Family	Non-Lead	Lead	9	Private Side Only
631 POTTERS AVE	631	POTTERS	AVE	PROVIDENCE	RI	02907	0.75	Multi-Family	Non-Lead	Lead	8	Private Side Only
481 POTTERS AVE	481	POTTERS	AVE	PROVIDENCE	RI	02907	1	Multi-Family	Non-Lead	Lead	9	Private Side Only
646 POTTERS AVE	646	POTTERS	AVE	PROVIDENCE	RI	02907	1	Mixed Residential & Nonresidential	Non-Lead	Lead	8	Private Side Only
827 POTTERS AVE	827	POTTERS	AVE	PROVIDENCE	RI	02907	1	Multi-Family	Non-Lead	Lead	8	Private Side Only
686 POTTERS AVE	686	POTTERS	AVE	PROVIDENCE	RI	02907	1	Multi-Family	Non-Lead	Lead	8	Private Side Only
404 POTTERS AVE	404	POTTERS	AVE	PROVIDENCE	RI	02907	1	Multi-Family	Non-Lead	Lead	9	Private Side Only
745 POTTERS AVE	745	POTTERS	AVE	PROVIDENCE	RI	02907	1	Multi-Family	Non-Lead	Lead	8	Private Side Only
374 POTTERS AVE	374	POTTERS	AVE	PROVIDENCE	RI	02907	1	Multi-Family	Non-Lead	Lead	9	Private Side Only
761 POTTERS AVE	761	POTTERS	AVE	PROVIDENCE	RI	02907	1	Mixed Residential & Nonresidential	Non-Lead	Lead	8	Private Side Only
366 POTTERS AVE	366	POTTERS	AVE	PROVIDENCE	RI	02907	1	Multi-Family	Non-Lead	Lead	9	Private Side Only
787 POTTERS AVE	787	POTTERS	AVE	PROVIDENCE	RI	02907	1	Multi-Family	Non-Lead	Lead	8	Private Side Only
513 POTTERS AVE	513	POTTERS	AVE	PROVIDENCE	RI	02907	1	Non residential	Non-Lead	Lead	9	Private Side Only
450 POTTERS AVE	450	POTTERS	AVE	PROVIDENCE	RI	02907	1	Non residential	Non-Lead	Lead	9	Private Side Only
417 POTTERS AVE	417	POTTERS	AVE	PROVIDENCE	RI	02907	1	Single-Family	Non-Lead	Lead	9	Private Side Only

FULL ADDRESS	HOUSE NUMBER	STREET	SUFFIX	CITY	STATE	ZIPCODE	SERVICE DIAMETER	BUILDING TYPE	PUBLIC SIDE MATERIAL	PRIVATE SIDE MATERIAL	WARD	REPLACEMENT TYPE
429 POTTERS AVE	429	POTTERS	AVE	PROVIDENCE	RI	02907	1	Multi-Family	Non-Lead	Lead	9	Private Side Only
819 POTTERS AVE	819	POTTERS	AVE	PROVIDENCE	RI	02907	1	Multi-Family	Non-Lead	Lead	8	Private Side Only
823 POTTERS AVE	823	POTTERS	AVE	PROVIDENCE	RI	02907	1	Multi-Family	Non-Lead	Lead	8	Private Side Only
449 POTTERS AVE	449	POTTERS	AVE	PROVIDENCE	RI	02907	1	Multi-Family	Non-Lead	Lead	9	Private Side Only
421 POTTERS AVE	421	POTTERS	AVE	PROVIDENCE	RI	02907	1	Multi-Family	Non-Lead	Lead	9	Private Side Only
727 POTTERS AVE	727	POTTERS	AVE	PROVIDENCE	RI	02907	1	Multi-Family	Non-Lead	Lead	8	Private Side Only
741 POTTERS AVE	741	POTTERS	AVE	PROVIDENCE	RI	02907	1	Multi-Family	Non-Lead	Lead	8	Private Side Only
619 POTTERS AVE	619	POTTERS	AVE	PROVIDENCE	RI	02907	1	Multi-Family	Non-Lead	Lead	8	Private Side Only
443 POTTERS AVE	443	POTTERS	AVE	PROVIDENCE	RI	02907	1	Multi-Family	Non-Lead	Lead	9	Private Side Only
636 POTTERS AVE	636	POTTERS	AVE	PROVIDENCE	RI	02907	1	Non residential	Non-Lead	Lead	8	Private Side Only
778 POTTERS AVE	778	POTTERS	AVE	PROVIDENCE	RI	02907	1	Multi-Family	Non-Lead	Lead	8	Private Side Only
804 POTTERS AVE	804	POTTERS	AVE	PROVIDENCE	RI	02907	1	Multi-Family	Non-Lead	Lead	8	Private Side Only
163 PRINCETON AVE	163	PRINCETON	AVE	PROVIDENCE	RI	02907	0.625	Multi-Family	Lead	Lead	8	Full
179 PRINCETON AVE	179	PRINCETON	AVE	PROVIDENCE	RI	02907	0.625	Multi-Family	Lead	Lead	8	Full
191 PRINCETON AVE	191	PRINCETON	AVE	PROVIDENCE	RI	02907	0.625	Multi-Family	Lead	Lead	8	Full
167 PRINCETON AVE	167	PRINCETON	AVE	PROVIDENCE	RI	02907	1	Multi-Family	Non-Lead	Lead	8	Private Side Only
185 PRINCETON AVE	185	PRINCETON	AVE	PROVIDENCE	RI	02907	0.625	Multi-Family	Lead	Lead	8	Full
169 PRINCETON AVE	169	PRINCETON	AVE	PROVIDENCE	RI	02907	0.625	Multi-Family	Lead	Lead	8	Full
149 PRINCETON AVE	149	PRINCETON	AVE	PROVIDENCE	RI	02907	0.625	Multi-Family	Lead	Lead	8	Full
155 PRINCETON AVE	155	PRINCETON	AVE	PROVIDENCE	RI	02907	1	Multi-Family	Non-Lead	Lead	8	Private Side Only
205 PRINCETON AVE	205	PRINCETON	AVE	PROVIDENCE	RI	02907	1	Multi-Family	Lead	Lead	8	Full
201 PRINCETON AVE	201	PRINCETON	AVE	PROVIDENCE	RI	02907	1	Multi-Family	Lead	Lead	8	Full
132 PRUDENCE AVE	132	PRUDENCE	AVE	PROVIDENCE	RI	02909	0.625	Multi-Family	Lead	Lead	7	Full
149 PRUDENCE AVE	149	PRUDENCE	AVE	PROVIDENCE	RI	02909	0.625	Multi-Family	Lead	Lead	7	Full
160 PRUDENCE AVE	160	PRUDENCE	AVE	PROVIDENCE	RI	02909	0.625	Mixed Residential & Nonresidential	Lead	Lead	7	Full
101 PRUDENCE AVE	101	PRUDENCE	AVE	PROVIDENCE	RI	02909	0.625	Multi-Family	Lead	Lead	7	Full
118 PRUDENCE AVE	118	PRUDENCE	AVE	PROVIDENCE	RI	02909	0.625	Multi-Family	Lead	Lead	7	Full
143 PRUDENCE AVE	143	PRUDENCE	AVE	PROVIDENCE	RI	02909	0.625	Multi-Family	Lead	Lead	7	Full
140 PRUDENCE AVE	140	PRUDENCE	AVE	PROVIDENCE	RI	02909	0.625	Multi-Family	Lead	Lead	7	Full
156 PRUDENCE AVE	156	PRUDENCE	AVE	PROVIDENCE	RI	02909	0.625	Multi-Family	Lead	Lead	7	Full
164 PRUDENCE AVE	164	PRUDENCE	AVE	PROVIDENCE	RI	02909	0.625	Multi-Family	Lead	Lead	7	Full
167 PRUDENCE AVE	167	PRUDENCE	AVE	PROVIDENCE	RI	02909	0.625	Single-Family	Lead	Lead	7	Full
144 PRUDENCE AVE	144	PRUDENCE	AVE	PROVIDENCE	RI	02909	1	Multi-Family	Non-Lead	Lead	7	Private Side Only
99 PRUDENCE AVE	99	PRUDENCE	AVE	PROVIDENCE	RI	02909	0.625	Multi-Family	Lead	Lead	7	Full
148 PRUDENCE AVE	148	PRUDENCE	AVE	PROVIDENCE	RI	02909	0.625	Multi-Family	Lead	Lead	7	Full
139 PRUDENCE AVE	139	PRUDENCE	AVE	PROVIDENCE	RI	02909	0.625	Single-Family	Lead	Lead	7	Full
153 PRUDENCE AVE	153	PRUDENCE	AVE	PROVIDENCE	RI	02909	0.625	Multi-Family	Lead	Lead	7	Full
136 PRUDENCE AVE	136	PRUDENCE	AVE	PROVIDENCE	RI	02909	0.625	Multi-Family	Lead	Lead	7	Full
161 PRUDENCE AVE	161	PRUDENCE	AVE	PROVIDENCE	RI	02909	0.625	Multi-Family	Lead	Lead	7	Full
634 UNION AVE	634	UNION	AVE	PROVIDENCE	RI	02909	1	Multi-Family	Non-Lead	Lead	7	Private Side Only
44 UNION AVE	44	UNION	AVE	PROVIDENCE	RI	02909	0.625	Multi-Family	Lead	Lead	8	Full

FULL ADDRESS	HOUSE NUMBER	STREET	SUFFIX	CITY	STATE	ZIPCODE	SERVICE DIAMETER	BUILDING TYPE	PUBLIC SIDE MATERIAL	PRIVATE SIDE MATERIAL	WARD	REPLACEMENT TYPE
60 UNION AVE	60	UNION	AVE	PROVIDENCE	RI	02909	0.625	Multi-Family	Lead	Lead	8	Full
584 UNION AVE	584	UNION	AVE	PROVIDENCE	RI	02909	1	Single-Family	Non-Lead	Lead	7	Private Side Only
43 UNION AVE	43	UNION	AVE	PROVIDENCE	RI	02909	0.625	Multi-Family	Lead	Lead	15	Full
579 UNION AVE	579	UNION	AVE	PROVIDENCE	RI	02909	1	Multi-Family	Non-Lead	Lead	7	Private Side Only
610 UNION AVE	610	UNION	AVE	PROVIDENCE	RI	02909	1	Multi-Family	Non-Lead	Lead	7	Private Side Only
620 UNION AVE	620	UNION	AVE	PROVIDENCE	RI	02909	1	Multi-Family	Non-Lead	Lead	7	Private Side Only
574 UNION AVE	574	UNION	AVE	PROVIDENCE	RI	02909	1	Multi-Family	Non-Lead	Lead	7	Private Side Only
605 UNION AVE	605	UNION	AVE	PROVIDENCE	RI	02909	1	Multi-Family	Non-Lead	Lead	7	Private Side Only
604 UNION AVE	604	UNION	AVE	PROVIDENCE	RI	02909	0.625	Multi-Family	Lead	Lead	7	Full
56 UNION AVE	56	UNION	AVE	PROVIDENCE	RI	02909	0.625	Multi-Family	Lead	Lead	8	Full
15 UNION AVE	15	UNION	AVE	PROVIDENCE	RI	02909	0.625	Multi-Family	Lead	Lead	15	Full
21 UNION AVE	21	UNION	AVE	PROVIDENCE	RI	02909	0.625	Multi-Family	Lead	Lead	15	Full
571 UNION AVE	571	UNION	AVE	PROVIDENCE	RI	02909	1	Multi-Family	Non-Lead	Lead	7	Private Side Only
593 UNION AVE	593	UNION	AVE	PROVIDENCE	RI	02909	1	Single-Family	Non-Lead	Lead	7	Private Side Only
598 UNION AVE	598	UNION	AVE	PROVIDENCE	RI	02909	0.625	Multi-Family	Lead	Lead	7	Full
39 UNION AVE	39	UNION	AVE	PROVIDENCE	RI	02909	0.625	Multi-Family	Lead	Lead	15	Full
580 UNION AVE	580	UNION	AVE	PROVIDENCE	RI	02909	0.625	Multi-Family	Lead	Lead	7	Full
570 UNION AVE	570	UNION	AVE	PROVIDENCE	RI	02909	1	Single-Family	Non-Lead	Lead	7	Private Side Only
603 UNION AVE	603	UNION	AVE	PROVIDENCE	RI	02909	0.625	Multi-Family	Lead	Lead	7	Full
588 UNION AVE	588	UNION	AVE	PROVIDENCE	RI	02909	0.625	Multi-Family	Lead	Lead	7	Full
624 UNION AVE	624	UNION	AVE	PROVIDENCE	RI	02909	0.625	Mixed Residential & Nonresidential	Lead	Lead	7	Full
48 UNION AVE	48	UNION	AVE	PROVIDENCE	RI	02909	0.625	Multi-Family	Lead	Lead	8	Full
630 UNION AVE	630	UNION	AVE	PROVIDENCE	RI	02909	1	Multi-Family	Non-Lead	Lead	7	Private Side Only
573 UNION AVE	573	UNION	AVE	PROVIDENCE	RI	02909	1	Multi-Family	Non-Lead	Lead	7	Private Side Only
25 UNION AVE	25	UNION	AVE	PROVIDENCE	RI	02909	0.625	Multi-Family	Lead	Lead	15	Full
59 UNION AVE	59	UNION	AVE	PROVIDENCE	RI	02909	0.625	Single-Family	Lead	Lead	15	Full
597 UNION AVE	597	UNION	AVE	PROVIDENCE	RI	02909	1	Multi-Family	Non-Lead	Lead	7	Private Side Only
67 UNION AVE	67	UNION	AVE	PROVIDENCE	RI	02909	0.625	Multi-Family	Lead	Lead	15	Full
590 UNION AVE	590	UNION	AVE	PROVIDENCE	RI	02909	1	Multi-Family	Non-Lead	Lead	7	Private Side Only
11 UNION AVE	11	UNION	AVE	PROVIDENCE	RI	02909	0.625	Multi-Family	Lead	Lead	15	Full
14 NEW HAMPSHIRE ST	14	NEW HAMPSHIRE	ST	CRANSTON	RI	02920	0.625	Multi-Family	Lead	Lead	5	Full
11 NEW HAMPSHIRE ST	11	NEW HAMPSHIRE	ST	CRANSTON	RI	02920	0.625	Single-Family	Lead	Lead	5	Full
38 NEW HAMPSHIRE ST	38	NEW HAMPSHIRE	ST	CRANSTON	RI	02920	0.625	Multi-Family	Lead	Lead	5	Full
23 NEW HAMPSHIRE ST	23	NEW HAMPSHIRE	ST	CRANSTON	RI	02920	0.625	Multi-Family	Lead	Lead	5	Full
17 NEW HAMPSHIRE ST	17	NEW HAMPSHIRE	ST	CRANSTON	RI	02920	0.625	Multi-Family	Lead	Lead	5	Full
64 NEW HAMPSHIRE ST	64	NEW HAMPSHIRE	ST	CRANSTON	RI	02920	0.625	Single-Family	Lead	Lead	5	Full
41 NEW HAMPSHIRE ST	41	NEW HAMPSHIRE	ST	CRANSTON	RI	02920	0.625	Multi-Family	Lead	Lead	5	Full
16 RHODE ISLAND ST	16	RHODE ISLAND	ST	CRANSTON	RI	02920	0.625	Single-Family	Lead	Lead	5	Full
33 RHODE ISLAND ST	33	RHODE ISLAND	ST	CRANSTON	RI	02920	0.625	Single-Family	Lead	Lead	5	Full
73 RHODE ISLAND ST	73	RHODE ISLAND	ST	CRANSTON	RI	02920	0.625	Single-Family	Lead	Lead	5	Full
15 RHODE ISLAND ST	15	RHODE ISLAND	ST	CRANSTON	RI	02920	0.625	Single-Family	Lead	Lead	5	Full

FULL ADDRESS	HOUSE NUMBER	STREET	SUFFIX	CITY	STATE	ZIPCODE	SERVICE DIAMETER	BUILDING TYPE	PUBLIC SIDE MATERIAL	PRIVATE SIDE MATERIAL	WARD	REPLACEMENT TYPE
25 RHODE ISLAND ST	25	RHODE ISLAND	ST	CRANSTON	RI	02920	0.625	Single-Family	Lead	Lead	5	Full
34 RHODE ISLAND ST	34	RHODE ISLAND	ST	CRANSTON	RI	02920	0.625	Single-Family	Lead	Lead	5	Full
100 RHODE ISLAND ST	100	RHODE ISLAND	ST	CRANSTON	RI	02920	0.625	Multi-Family	Lead	Lead	5	Full
25 ST MARYS DR	25	ST MARYS	DR	CRANSTON	RI	02920	0.625	Multi-Family	Lead	Lead	5	Full
34 ST MARYS DR	34	ST MARYS	DR	CRANSTON	RI	02920	0.625	Multi-Family	Lead	Lead	5	Full
11 ST MARYS DR	11	ST MARYS	DR	CRANSTON	RI	02920	0.75	Multi-Family	Lead	Lead	5	Full
9 ST MARYS DR	9	ST MARYS	DR	CRANSTON	RI	02920	0.625	Multi-Family	Lead	Lead	5	Full
15 ST MARYS DR	15	ST MARYS	DR	CRANSTON	RI	02920	0.625	Multi-Family	Lead	Lead	5	Full
56 OLD OAK AVE	56	OLD OAK	AVE	CRANSTON	RI	02920	0.625	Multi-Family	Lead	Lead	3	Full
63 OLD OAK AVE	63	OLD OAK	AVE	CRANSTON	RI	02920	0.625	Single-Family	Lead	Lead	3	Full
105 OLD OAK AVE	105	OLD OAK	AVE	CRANSTON	RI	02920	0.625	Multi-Family	Lead	Lead	3	Full
11 OLD OAK AVE	11	OLD OAK	AVE	CRANSTON	RI	02920		1 Multi-Family	Non-Lead	Lead	3	Private Side Only
102 OLD OAK AVE	102	OLD OAK	AVE	CRANSTON	RI	02920	0.625	Multi-Family	Lead	Lead	3	Full
84 OLD OAK AVE	84	OLD OAK	AVE	CRANSTON	RI	02920	0.625	Multi-Family	Lead	Lead	3	Full
99 OLD OAK AVE	99	OLD OAK	AVE	CRANSTON	RI	02920	0.625	Multi-Family	Lead	Lead	3	Full
51 OLD OAK AVE	51	OLD OAK	AVE	CRANSTON	RI	02920	0.625	Single-Family	Lead	Lead	3	Full
35 OLD OAK AVE	35	OLD OAK	AVE	CRANSTON	RI	02920	0.625	Single-Family	Lead	Lead	3	Full
46 OLD OAK AVE	46	OLD OAK	AVE	CRANSTON	RI	02920	0.625	Single-Family	Lead	Lead	3	Full
92 OLD OAK AVE	92	OLD OAK	AVE	CRANSTON	RI	02920	0.625	Single-Family	Lead	Lead	3	Full
12 OLD OAK AVE	12	OLD OAK	AVE	CRANSTON	RI	02920		1 Multi-Family	Non-Lead	Lead	3	Private Side Only
87 OLD OAK AVE	87	OLD OAK	AVE	CRANSTON	RI	02920	0.625	Multi-Family	Lead	Lead	3	Full
22 VALLONE RD	22	VALLONE	RD	CRANSTON	RI	02920	0.625	Single-Family	Lead	Non-Lead	5	Public Side Only
26 VALLONE RD	26	VALLONE	RD	CRANSTON	RI	02920	0.625	Single-Family	Lead	Lead	5	Full
15 VALLONE RD	15	VALLONE	RD	CRANSTON	RI	02920	0.625	Multi-Family	Lead	Lead	5	Full
9 ADIE ST	9	ADIE	ST	CRANSTON	RI	02920		1 Multi-Family	Non-Lead	Lead	5	Private Side Only
12 ADIE ST	12	ADIE	ST	CRANSTON	RI	02920		1 Single-Family	Non-Lead	Lead	5	Private Side Only
10 ADIE ST	10	ADIE	ST	CRANSTON	RI	02920	0.75	Single-Family	Non-Lead	Lead	5	Private Side Only
152 ALTHEA ST	152	ALTHEA	ST	PROVIDENCE	RI	02907	0.625	Multi-Family	Lead	Lead	8	Full
87 ALTHEA ST	87	ALTHEA	ST	PROVIDENCE	RI	02907	0.625	Multi-Family	Lead	Lead	8	Full
57 ALTHEA ST	57	ALTHEA	ST	PROVIDENCE	RI	02907		1 Single-Family	Non-Lead	Lead	8	Private Side Only
50 ALTHEA ST	50	ALTHEA	ST	PROVIDENCE	RI	02907	0.625	Multi-Family	Lead	Lead	8	Full
94 ALTHEA ST	94	ALTHEA	ST	PROVIDENCE	RI	02907	0.625	Multi-Family	Lead	Lead	8	Full
108 ALTHEA ST	108	ALTHEA	ST	PROVIDENCE	RI	02907	0.75	Multi-Family	Lead	Lead	8	Full
111 ALTHEA ST	111	ALTHEA	ST	PROVIDENCE	RI	02907	0.625	Multi-Family	Lead	Lead	8	Full
99 ALTHEA ST	99	ALTHEA	ST	PROVIDENCE	RI	02907		1 Multi-Family	Lead	Non-Lead	8	Public Side Only
126 ALTHEA ST	126	ALTHEA	ST	PROVIDENCE	RI	02907	0.625	Multi-Family	Lead	Lead	8	Full
49 ALTHEA ST	49	ALTHEA	ST	PROVIDENCE	RI	02907		1 Single-Family	Non-Lead	Lead	8	Private Side Only
143 ALTHEA ST	143	ALTHEA	ST	PROVIDENCE	RI	02907	0.625	Multi-Family	Lead	Lead	8	Full
84 ALTHEA ST	84	ALTHEA	ST	PROVIDENCE	RI	02907	0.625	Single-Family	Lead	Lead	8	Full
39 ALTHEA ST	39	ALTHEA	ST	PROVIDENCE	RI	02907	0.625	Single-Family	Lead	Lead	8	Full
138 ALTHEA ST	138	ALTHEA	ST	PROVIDENCE	RI	02907	0.625	Multi-Family	Lead	Lead	8	Full

FULL ADDRESS	HOUSE NUMBER	STREET	SUFFIX	CITY	STATE	ZIPCODE	SERVICE DIAMETER	BUILDING TYPE	PUBLIC SIDE MATERIAL	PRIVATE SIDE MATERIAL	WARD	REPLACEMENT TYPE
151 ALTHEA ST	151	ALTHEA	ST	PROVIDENCE	RI	02907	0.625	Multi-Family	Lead	Lead	8	Full
114 ALTHEA ST	114	ALTHEA	ST	PROVIDENCE	RI	02907	1	Multi-Family	Non-Lead	Lead	8	Private Side Only
45 ALTHEA ST	45	ALTHEA	ST	PROVIDENCE	RI	02907	0.75	Single-Family	Non-Lead	Lead	8	Private Side Only
142 ALTHEA ST	142	ALTHEA	ST	PROVIDENCE	RI	02907	0.625	Multi-Family	Lead	Lead	8	Full
73 ALTHEA ST	73	ALTHEA	ST	PROVIDENCE	RI	02907	0.625	Multi-Family	Lead	Lead	8	Full
33 ALTHEA ST	33	ALTHEA	ST	PROVIDENCE	RI	02907	0.625	Multi-Family	Lead	Lead	8	Full
80 ALTHEA ST	80	ALTHEA	ST	PROVIDENCE	RI	02907	0.625	Multi-Family	Lead	Lead	8	Full
117 ALTHEA ST	117	ALTHEA	ST	PROVIDENCE	RI	02907	0.625	Multi-Family	Lead	Lead	8	Full
120 ALTHEA ST	120	ALTHEA	ST	PROVIDENCE	RI	02907	0.75	Multi-Family	Lead	Lead	8	Full
139 ALTHEA ST	139	ALTHEA	ST	PROVIDENCE	RI	02907	0.625	Multi-Family	Lead	Lead	8	Full
90 ALTHEA ST	90	ALTHEA	ST	PROVIDENCE	RI	02907	0.625	Single-Family	Lead	Lead	8	Full
113 ALTHEA ST	113	ALTHEA	ST	PROVIDENCE	RI	02907	0.625	Multi-Family	Lead	Lead	8	Full
70 ALTHEA ST	70	ALTHEA	ST	PROVIDENCE	RI	02907	0.625	Multi-Family	Lead	Lead	8	Full
127 ALTHEA ST	127	ALTHEA	ST	PROVIDENCE	RI	02907	0.625	Multi-Family	Lead	Lead	8	Full
74 ALTHEA ST	74	ALTHEA	ST	PROVIDENCE	RI	02907	0.625	Multi-Family	Lead	Lead	8	Full
105 ALTHEA ST	105	ALTHEA	ST	PROVIDENCE	RI	02907	1	Multi-Family	Non-Lead	Lead	8	Private Side Only
86 ALTHEA ST	86	ALTHEA	ST	PROVIDENCE	RI	02907	1	Multi-Family	Non-Lead	Lead	8	Private Side Only
148 ALTHEA ST	148	ALTHEA	ST	PROVIDENCE	RI	02907	1	Multi-Family	Non-Lead	Lead	8	Private Side Only
42 ALTHEA ST	42	ALTHEA	ST	PROVIDENCE	RI	02907	0.75	Multi-Family	Lead	Lead	8	Full
133 ALTHEA ST	133	ALTHEA	ST	PROVIDENCE	RI	02907	0.625	Multi-Family	Lead	Lead	8	Full
18 AMERICA ST	18	AMERICA	ST	CRANSTON	RI	02920	0.625	Multi-Family	Lead	Lead	5	Full
16 AMERICA ST	16	AMERICA	ST	CRANSTON	RI	02920	0.625	Multi-Family	Lead	Lead	5	Full
17 AMERICA ST	17	AMERICA	ST	CRANSTON	RI	02920	0.625	Multi-Family	Lead	Lead	5	Full
15 APLIN ST	15	APLIN	ST	CRANSTON	RI	02920	0.75	Single-Family	Non-Lead	Lead	5	Private Side Only
66 BRIGGS ST	66	BRIGGS	ST	CRANSTON	RI	02920	0.625	Single-Family	Lead	Lead	5	Full
42 BRIGGS ST	42	BRIGGS	ST	CRANSTON	RI	02920	1	Single-Family	Lead	Lead	5	Full
33 BRIGGS ST	33	BRIGGS	ST	CRANSTON	RI	02920	0.625	Multi-Family	Lead	Lead	5	Full
48 BRIGGS ST	48	BRIGGS	ST	CRANSTON	RI	02920	0.625	Multi-Family	Lead	Lead	5	Full
37 BRIGGS ST	37	BRIGGS	ST	CRANSTON	RI	02920	1	Multi-Family	Non-Lead	Lead	5	Private Side Only
44 BRIGGS ST	44	BRIGGS	ST	CRANSTON	RI	02920	1	Multi-Family	Non-Lead	Lead	5	Private Side Only
29 BRIGGS ST	29	BRIGGS	ST	CRANSTON	RI	02920	0.625	Multi-Family	Lead	Lead	5	Full
38 BRIGGS ST	38	BRIGGS	ST	CRANSTON	RI	02920	0.625	Single-Family	Lead	Lead	5	Full
897 BROAD ST	897	BROAD	ST	PROVIDENCE	RI	02907	1	Mixed Residential & Nonresidential	Non-Lead	Lead	9	Private Side Only
903 BROAD ST	903	BROAD	ST	PROVIDENCE	RI	02907	1	Non residential	Non-Lead	Lead	9	Private Side Only
773 BROAD ST	773	BROAD	ST	PROVIDENCE	RI	02907	1	Non residential	Non-Lead	Lead	9	Private Side Only
767 BROAD ST	767	BROAD	ST	PROVIDENCE	RI	02907	1	Non residential	Non-Lead	Lead	9	Private Side Only
759 BROAD ST	759	BROAD	ST	PROVIDENCE	RI	02907	1	Mixed Residential & Nonresidential	Non-Lead	Lead	9	Private Side Only
747 BROAD ST	747	BROAD	ST	PROVIDENCE	RI	02907	1	Non residential	Non-Lead	Lead	9	Private Side Only
279 BUCKLIN ST	279	BUCKLIN	ST	PROVIDENCE	RI	02907	1	Multi-Family	Non-Lead	Lead	8	Private Side Only
303 BUCKLIN ST	303	BUCKLIN	ST	PROVIDENCE	RI	02907	1	Multi-Family	Non-Lead	Lead	8	Private Side Only
205 BUCKLIN ST	205	BUCKLIN	ST	PROVIDENCE	RI	02907	0.625	Single-Family	Lead	Lead	8	Full

FULL ADDRESS	HOUSE NUMBER	STREET	SUFFIX	CITY	STATE	ZIPCODE	SERVICE DIAMETER	BUILDING TYPE	PUBLIC SIDE MATERIAL	PRIVATE SIDE MATERIAL	WARD	REPLACEMENT TYPE
101 BUCKLIN ST	101	BUCKLIN	ST	PROVIDENCE	RI	02907	1.25	Non residential	Lead	Lead	8	Full
346 BUCKLIN ST	346	BUCKLIN	ST	PROVIDENCE	RI	02907	1	Multi-Family	Non-Lead	Lead	8	Private Side Only
245 BUCKLIN ST	245	BUCKLIN	ST	PROVIDENCE	RI	02907	1	Multi-Family	Non-Lead	Lead	8	Private Side Only
96 BUCKLIN ST	96	BUCKLIN	ST	PROVIDENCE	RI	02907	0.75	Multi-Family	Lead	Lead	8	Full
215 BUCKLIN ST	215	BUCKLIN	ST	PROVIDENCE	RI	02907	0.625	Single-Family	Lead	Lead	8	Full
316 BUCKLIN ST	316	BUCKLIN	ST	PROVIDENCE	RI	02907	1	Multi-Family	Non-Lead	Lead	8	Private Side Only
201 BUCKLIN ST	201	BUCKLIN	ST	PROVIDENCE	RI	02907	0.625	Multi-Family	Lead	Lead	8	Full
305 BUCKLIN ST	305	BUCKLIN	ST	PROVIDENCE	RI	02907	1	Multi-Family	Non-Lead	Lead	8	Private Side Only
143 BURNETT ST	143	BURNETT	ST	PROVIDENCE	RI	02907	1	Multi-Family	Non-Lead	Lead	8	Private Side Only
59 BURNETT ST	59	BURNETT	ST	PROVIDENCE	RI	02904	1	Multi-Family	Non-Lead	Lead	8	Private Side Only
141 BURNETT ST	141	BURNETT	ST	PROVIDENCE	RI	02907	0.625	Multi-Family	Lead	Lead	8	Full
77 BURNETT ST	77	BURNETT	ST	PROVIDENCE	RI	02907	0.625	Single-Family	Lead	Lead	8	Full
123 BURNETT ST	123	BURNETT	ST	PROVIDENCE	RI	02907	0.625	Multi-Family	Lead	Lead	8	Full
111 BURNETT ST	111	BURNETT	ST	PROVIDENCE	RI	02907	0.625	Multi-Family	Lead	Lead	8	Full
110 BURNETT ST	110	BURNETT	ST	PROVIDENCE	RI	02907	0.625	Single-Family	Lead	Lead	8	Full
146 BURNETT ST	146	BURNETT	ST	PROVIDENCE	RI	02907	1	Single-Family	Non-Lead	Lead	8	Private Side Only
133 BURNETT ST	133	BURNETT	ST	PROVIDENCE	RI	02907	0.625	Multi-Family	Lead	Lead	8	Full
139 BURNETT ST	139	BURNETT	ST	PROVIDENCE	RI	02907	0.625	Multi-Family	Lead	Lead	8	Full
117 BURNETT ST	117	BURNETT	ST	PROVIDENCE	RI	02907	0.625	Multi-Family	Lead	Lead	8	Full
95 BURNETT ST	95	BURNETT	ST	PROVIDENCE	RI	02907	0.625	Multi-Family	Lead	Lead	8	Full
150 BURNETT ST	150	BURNETT	ST	PROVIDENCE	RI	02907	0.75	Multi-Family	Lead	Lead	8	Full
71 BURNETT ST	71	BURNETT	ST	PROVIDENCE	RI	02907	0.75	Multi-Family	Lead	Lead	8	Full
63 BURNETT ST	63	BURNETT	ST	PROVIDENCE	RI	02904	1	Single-Family	Non-Lead	Lead	8	Private Side Only
108 BURNETT ST	108	BURNETT	ST	PROVIDENCE	RI	02907	1	Multi-Family	Non-Lead	Lead	8	Private Side Only
140 BURNETT ST	140	BURNETT	ST	PROVIDENCE	RI	02907	0.625	Multi-Family	Lead	Lead	8	Full
33 CALDER ST	33	CALDER	ST	PROVIDENCE	RI	02907	1	Multi-Family	Non-Lead	Lead	8	Private Side Only
38 CALDER ST	38	CALDER	ST	PROVIDENCE	RI	02907	1	Multi-Family	Non-Lead	Lead	8	Private Side Only
12 CALDER ST	12	CALDER	ST	PROVIDENCE	RI	02907	1	Multi-Family	Non-Lead	Lead	8	Private Side Only
40 CALDER ST	40	CALDER	ST	PROVIDENCE	RI	02907	1	Single-Family	Non-Lead	Lead	8	Private Side Only
43 CALDER ST	43	CALDER	ST	PROVIDENCE	RI	02907	1	Multi-Family	Non-Lead	Lead	8	Private Side Only
36 CALDER ST	36	CALDER	ST	PROVIDENCE	RI	02907	1	Multi-Family	Non-Lead	Lead	8	Private Side Only
20 CALDER ST	20	CALDER	ST	PROVIDENCE	RI	02907	1	Multi-Family	Non-Lead	Lead	8	Private Side Only
42 CALDER ST	42	CALDER	ST	PROVIDENCE	RI	02907	1	Multi-Family	Non-Lead	Lead	8	Private Side Only
25 CARTER ST	25	CARTER	ST	PROVIDENCE	RI	02907	1	Single-Family	Non-Lead	Lead	8	Private Side Only
38 CARTER ST	38	CARTER	ST	PROVIDENCE	RI	02907	1	Multi-Family	Non-Lead	Lead	8	Private Side Only
41 CARTER ST	41	CARTER	ST	PROVIDENCE	RI	02907	1	Multi-Family	Non-Lead	Lead	8	Private Side Only
24 CARTER ST	24	CARTER	ST	PROVIDENCE	RI	02907	1	Single-Family	Non-Lead	Lead	8	Private Side Only
32 CARTER ST	32	CARTER	ST	PROVIDENCE	RI	02907	1	Single-Family	Non-Lead	Lead	8	Private Side Only
39 CAVALRY ST	39	CAVALRY	ST	CRANSTON	RI	02920	0.625	Single-Family	Lead	Lead	5	Full
42 CAVALRY ST	42	CAVALRY	ST	CRANSTON	RI	02920	0.625	Multi-Family	Lead	Lead	5	Full
32 CAVALRY ST	32	CAVALRY	ST	CRANSTON	RI	02920	0.625	Multi-Family	Lead	Lead	5	Full

FULL ADDRESS	HOUSE NUMBER	STREET	SUFFIX	CITY	STATE	ZIPCODE	SERVICE DIAMETER	BUILDING TYPE	PUBLIC SIDE MATERIAL	PRIVATE SIDE MATERIAL	WARD	REPLACEMENT TYPE
27 CEDAR ST	27	CEDAR	ST	CRANSTON	RI	02910	0.75	Multi-Family	Lead	Lead	3	Full
15 CEDAR ST	15	CEDAR	ST	CRANSTON	RI	02910	0.75	Multi-Family	Lead	Lead	3	Full
25 CEDAR ST	25	CEDAR	ST	CRANSTON	RI	02910	0.75	Multi-Family	Lead	Lead	3	Full
10 CHAMBERS ST	10	CHAMBERS	ST	PROVIDENCE	RI	02907	1	Multi-Family	Non-Lead	Lead	8	Private Side Only
42 CHAMBERS ST	42	CHAMBERS	ST	PROVIDENCE	RI	02907	1	Single-Family	Non-Lead	Lead	8	Private Side Only
15 CHAMBERS ST	15	CHAMBERS	ST	PROVIDENCE	RI	02907	1	Multi-Family	Non-Lead	Lead	8	Private Side Only
50 CHAMBERS ST	50	CHAMBERS	ST	PROVIDENCE	RI	02907	1	Single-Family	Non-Lead	Lead	8	Private Side Only
35 CHAMBERS ST	35	CHAMBERS	ST	PROVIDENCE	RI	02907	1	Multi-Family	Non-Lead	Lead	8	Private Side Only
23 CHAMBERS ST	23	CHAMBERS	ST	PROVIDENCE	RI	02907	1	Multi-Family	Non-Lead	Lead	8	Private Side Only
26 CHAMBERS ST	26	CHAMBERS	ST	PROVIDENCE	RI	02907	1	Multi-Family	Non-Lead	Lead	8	Private Side Only
24 CHAMBERS ST	24	CHAMBERS	ST	PROVIDENCE	RI	02907	1	Single-Family	Non-Lead	Lead	8	Private Side Only
14 CHAMBERS ST	14	CHAMBERS	ST	PROVIDENCE	RI	02907	1	Multi-Family	Non-Lead	Lead	8	Private Side Only
54 CHAMBERS ST	54	CHAMBERS	ST	PROVIDENCE	RI	02907	1	Multi-Family	Non-Lead	Lead	8	Private Side Only
38 CHAMBERS ST	38	CHAMBERS	ST	PROVIDENCE	RI	02907	1	Single-Family	Non-Lead	Lead	8	Private Side Only
34 CHAMBERS ST	34	CHAMBERS	ST	PROVIDENCE	RI	02907	1	Multi-Family	Non-Lead	Lead	8	Private Side Only
35 CHURCH ST	35	CHURCH	ST	CRANSTON	RI	02920	0.625	Multi-Family	Lead	Lead	5	Full
39 CHURCH ST	39	CHURCH	ST	CRANSTON	RI	02920	0.625	Single-Family	Lead	Lead	5	Full
68 COLWELL ST	68	COLWELL	ST	CRANSTON	RI	02920	0.625	Multi-Family	Lead	Lead	5	Full
79 COLWELL ST	79	COLWELL	ST	CRANSTON	RI	02920	0.625	Multi-Family	Lead	Lead	5	Full
9 COLWELL ST	9	COLWELL	ST	CRANSTON	RI	02920	0.625	Multi-Family	Lead	Lead	5	Full
28 CONNECTICUT ST	28	CONNECTICUT	ST	CRANSTON	RI	02920	0.625	Multi-Family	Lead	Lead	5	Full
84 CONNECTICUT ST	84	CONNECTICUT	ST	CRANSTON	RI	02920	0.625	Single-Family	Lead	Lead	5	Full
1548 CRANSTON ST	1548	CRANSTON	ST	CRANSTON	RI	02920	0.625	Single-Family	Lead	Non-Lead	5	Public Side Only
1686 CRANSTON ST	1686	CRANSTON	ST	CRANSTON	RI	02920	0.625	Non residential	Lead	Lead	5	Full
1663 CRANSTON ST	1663	CRANSTON	ST	CRANSTON	RI	02920	0.625	Mixed Residential & Nonresidential	Lead	Lead	5	Full
1630 CRANSTON ST	1630	CRANSTON	ST	CRANSTON	RI	02920	0.625	Multi-Family	Lead	Non-Lead	5	Public Side Only
724 CRANSTON ST	724	CRANSTON	ST	PROVIDENCE	RI	02907	0.625	Non residential	Lead	Lead	8	Full
1561 CRANSTON ST	1561	CRANSTON	ST	CRANSTON	RI	02920	0.625	Single-Family	Lead	Non-Lead	5	Public Side Only
778 CRANSTON ST	778	CRANSTON	ST	PROVIDENCE	RI	02907	0.625	Non residential	Lead	Lead	8	Full
700 CRANSTON ST	700	CRANSTON	ST	PROVIDENCE	RI	02907	0.625	Mixed Residential & Nonresidential	Lead	Lead	8	Full
584 CRANSTON ST	584	CRANSTON	ST	PROVIDENCE	RI	02907	0.625	Non residential	Lead	Lead	8	Full
1560 CRANSTON ST	1560	CRANSTON	ST	CRANSTON	RI	02920	0.625	Single-Family	Lead	Lead	5	Full
1545 CRANSTON ST	1545	CRANSTON	ST	CRANSTON	RI	02920	0.625	Multi-Family	Lead	Lead	5	Full
717 CRANSTON ST	717	CRANSTON	ST	PROVIDENCE	RI	02907	0.75	Non residential	Lead	Lead	8	Full
1574 CRANSTON ST	1574	CRANSTON	ST	CRANSTON	RI	02920	0.625	Multi-Family	Lead	Lead	5	Full
1528 CRANSTON ST	1528	CRANSTON	ST	CRANSTON	RI	02920	0.625	Non residential	Lead	Lead	5	Full
701 CRANSTON ST	701	CRANSTON	ST	PROVIDENCE	RI	02907	0.625	Non residential	Lead	Lead	8	Full
1487 CRANSTON ST	1487	CRANSTON	ST	CRANSTON	RI	02920	0.625	Multi-Family	Lead	Lead	5	Full
1580 CRANSTON ST	1580	CRANSTON	ST	CRANSTON	RI	02920	0.625	Multi-Family	Lead	Lead	5	Full
1523 CRANSTON ST	1523	CRANSTON	ST	CRANSTON	RI	02920	1.25	Non residential	Lead	Lead	5	Full
1598 CRANSTON ST	1598	CRANSTON	ST	CRANSTON	RI	02920	0.625	Single-Family	Lead	Lead	5	Full

FULL ADDRESS	HOUSE NUMBER	STREET	SUFFIX	CITY	STATE	ZIPCODE	SERVICE DIAMETER	BUILDING TYPE	PUBLIC SIDE MATERIAL	PRIVATE SIDE MATERIAL	WARD	REPLACEMENT TYPE
710 CRANSTON ST	710	CRANSTON	ST	PROVIDENCE	RI	02907	1	Mixed Residential & Nonresidential	Non-Lead	Lead	8	Private Side Only
1390 CRANSTON ST	1390	CRANSTON	ST	CRANSTON	RI	02920	0.625	Non residential	Lead	Lead	3	Full
596 CRANSTON ST	596	CRANSTON	ST	PROVIDENCE	RI	02907	0.625	Mixed Residential & Nonresidential	Lead	Lead	8	Full
1564 CRANSTON ST	1564	CRANSTON	ST	CRANSTON	RI	02920	0.625	Mixed Residential & Nonresidential	Lead	Lead	5	Full
1606 CRANSTON ST	1606	CRANSTON	ST	CRANSTON	RI	02920	0.625	Mixed Residential & Nonresidential	Lead	Lead	5	Full
594 CRANSTON ST	594	CRANSTON	ST	PROVIDENCE	RI	02907	0.75	Non residential	Lead	Lead	8	Full
1675 CRANSTON ST	1675	CRANSTON	ST	CRANSTON	RI	02920	0.625	Mixed Residential & Nonresidential	Lead	Lead	5	Full
1400 CRANSTON ST	1400	CRANSTON	ST	CRANSTON	RI	02920	0.75	Non residential	Lead	Lead	3	Full
1681 CRANSTON ST	1681	CRANSTON	ST	CRANSTON	RI	02920	0.625	Non residential	Lead	Lead	5	Full
1615 CRANSTON ST	1615	CRANSTON	ST	CRANSTON	RI	02920	0.625	Multi-Family	Lead	Lead	5	Full
1640 CRANSTON ST	1640	CRANSTON	ST	CRANSTON	RI	02920	0.625	Single-Family	Lead	Lead	5	Full
562 CRANSTON ST	562	CRANSTON	ST	PROVIDENCE	RI	02907	0.625	Mixed Residential & Nonresidential	Lead	Lead	8	Full
748 CRANSTON ST	748	CRANSTON	ST	PROVIDENCE	RI	02907	0.75	Non residential	Non-Lead	Lead	8	Private Side Only
1578 CRANSTON ST	1578	CRANSTON	ST	CRANSTON	RI	02920	0.625	Mixed Residential & Nonresidential	Lead	Lead	5	Full
744 CRANSTON ST	744	CRANSTON	ST	PROVIDENCE	RI	02907	0.625	Non residential	Lead	Lead	8	Full
1616 CRANSTON ST	1616	CRANSTON	ST	CRANSTON	RI	02920	0.625	Multi-Family	Lead	Lead	5	Full
1477 CRANSTON ST	1477	CRANSTON	ST	CRANSTON	RI	02920	1	Multi-Family	Non-Lead	Lead	5	Private Side Only
1664 CRANSTON ST	1664	CRANSTON	ST	CRANSTON	RI	02920	0.625	Single-Family	Lead	Lead	5	Full
1669 CRANSTON ST	1669	CRANSTON	ST	CRANSTON	RI	02920	0.625	Non residential	Lead	Lead	5	Full
1698 CRANSTON ST	1698	CRANSTON	ST	CRANSTON	RI	02920	1	Mixed Residential & Nonresidential	Non-Lead	Lead	5	Private Side Only
1494 CRANSTON ST	1494	CRANSTON	ST	CRANSTON	RI	02920	0.625	Multi-Family	Lead	Lead	5	Full
735 CRANSTON ST	735	CRANSTON	ST	PROVIDENCE	RI	02907	0.625	Mixed Residential & Nonresidential	Lead	Lead	8	Full
1573 CRANSTON ST	1573	CRANSTON	ST	CRANSTON	RI	02920	0.625	Single-Family	Lead	Lead	5	Full
1627 CRANSTON ST	1627	CRANSTON	ST	CRANSTON	RI	02920	0.625	Multi-Family	Lead	Lead	5	Full
194 DABOLL ST	194	DABOLL	ST	PROVIDENCE	RI	02907	1	Multi-Family	Non-Lead	Lead	8	Private Side Only
188 DABOLL ST	188	DABOLL	ST	PROVIDENCE	RI	02907	0.625	Single-Family	Lead	Lead	8	Full
540 DEXTER ST	540	DEXTER	ST	PROVIDENCE	RI	02907	1	Multi-Family	Non-Lead	Lead	8	Private Side Only
544 DEXTER ST	544	DEXTER	ST	PROVIDENCE	RI	02907	1	Single-Family	Non-Lead	Lead	8	Private Side Only
483 DEXTER ST	483	DEXTER	ST	PROVIDENCE	RI	02907	0.625	Single-Family	Lead	Lead	8	Full
502 DEXTER ST	502	DEXTER	ST	PROVIDENCE	RI	02907	0.625	Multi-Family	Lead	Lead	8	Full
551 DEXTER ST	551	DEXTER	ST	PROVIDENCE	RI	02907	1	Multi-Family	Non-Lead	Lead	8	Private Side Only
23 EARL ST	23	EARL	ST	PROVIDENCE	RI	02907	1	Multi-Family	Non-Lead	Lead	8	Private Side Only
17 EARL ST	17	EARL	ST	PROVIDENCE	RI	02907	1	Multi-Family	Non-Lead	Lead	8	Private Side Only
156 ELWIN ST	156	ELWIN	ST	CRANSTON	RI	02920	0.625	Single-Family	Lead	Lead	3	Full
109 ETHAN ST	109	ETHAN	ST	PROVIDENCE	RI	02909	0.625	Multi-Family	Lead	Lead	7	Full
32 ETHAN ST	32	ETHAN	ST	PROVIDENCE	RI	02909	0.625	Single-Family	Lead	Lead	7	Full
35 ETHAN ST	35	ETHAN	ST	PROVIDENCE	RI	02909	1	Multi-Family	Non-Lead	Lead	7	Private Side Only
43 ETHAN ST	43	ETHAN	ST	PROVIDENCE	RI	02909	0.625	Single-Family	Lead	Lead	7	Full
22 ETHAN ST	22	ETHAN	ST	PROVIDENCE	RI	02909	0.625	Single-Family	Lead	Lead	7	Full
115 ETHAN ST	115	ETHAN	ST	PROVIDENCE	RI	02909	0.625	Single-Family	Lead	Lead	7	Full
105 ETHAN ST	105	ETHAN	ST	PROVIDENCE	RI	02909	0.625	Multi-Family	Lead	Lead	7	Full

FULL ADDRESS	HOUSE NUMBER	STREET	SUFFIX	CITY	STATE	ZIPCODE	SERVICE DIAMETER	BUILDING TYPE	PUBLIC SIDE MATERIAL	PRIVATE SIDE MATERIAL	WARD	REPLACEMENT TYPE
106 ETHAN ST	106	ETHAN	ST	PROVIDENCE	RI	02909	1	Multi-Family	Non-Lead	Lead	7	Private Side Only
45 ETHAN ST	45	ETHAN	ST	PROVIDENCE	RI	02909	0.625	Multi-Family	Lead	Lead	7	Full
108 ETHAN ST	108	ETHAN	ST	PROVIDENCE	RI	02909	0.625	Multi-Family	Lead	Lead	7	Full
150 FORD ST	150	FORD	ST	PROVIDENCE	RI	02909	1	Single-Family	Non-Lead	Lead	15	Private Side Only
164 GLADSTONE ST	164	GLADSTONE	ST	CRANSTON	RI	02920	0.625	Single-Family	Lead	Lead	3	Full
156 GLADSTONE ST	156	GLADSTONE	ST	CRANSTON	RI	02920	0.625	Single-Family	Lead	Lead	3	Full
28 GRAND ST	28	GRAND	ST	PROVIDENCE	RI	02907	1	Single-Family	Non-Lead	Lead	8	Private Side Only
40 GRAND ST	40	GRAND	ST	PROVIDENCE	RI	02907	1	Single-Family	Non-Lead	Lead	8	Private Side Only
36 GRAND ST	36	GRAND	ST	PROVIDENCE	RI	02907	1	Single-Family	Non-Lead	Lead	8	Private Side Only
56 GRAND ST	56	GRAND	ST	PROVIDENCE	RI	02907	1	Single-Family	Non-Lead	Lead	8	Private Side Only
17 GRAND ST	17	GRAND	ST	PROVIDENCE	RI	02907	1	Multi-Family	Non-Lead	Lead	8	Private Side Only
51 GRAND ST	51	GRAND	ST	PROVIDENCE	RI	02907	1	Single-Family	Non-Lead	Lead	8	Private Side Only
31 GRAND ST	31	GRAND	ST	PROVIDENCE	RI	02907	1	Multi-Family	Non-Lead	Lead	8	Private Side Only
27 GRAND ST	27	GRAND	ST	PROVIDENCE	RI	02907	1	Single-Family	Non-Lead	Lead	8	Private Side Only
32 GRAND ST	32	GRAND	ST	PROVIDENCE	RI	02907	1	Single-Family	Non-Lead	Lead	8	Private Side Only
23 GRAND ST	23	GRAND	ST	PROVIDENCE	RI	02907	1	Single-Family	Non-Lead	Lead	8	Private Side Only
33 GREENWICH ST	33	GREENWICH	ST	PROVIDENCE	RI	02907	0.75	Non residential	Lead	Lead	8	Full
78 GREENWICH ST	78	GREENWICH	ST	PROVIDENCE	RI	02907	1	Non residential	Non-Lead	Lead	8	Private Side Only
61 GREENWICH ST	61	GREENWICH	ST	PROVIDENCE	RI	02907	0.625	Multi-Family	Lead	Lead	8	Full
43 GREENWICH ST	43	GREENWICH	ST	PROVIDENCE	RI	02907	0.625	Multi-Family	Lead	Lead	8	Full
29 GREENWICH ST	29	GREENWICH	ST	PROVIDENCE	RI	02907	0.625	Multi-Family	Lead	Non-Lead	8	Public Side Only
37 GREENWICH ST	37	GREENWICH	ST	PROVIDENCE	RI	02907	0.625	Multi-Family	Lead	Lead	8	Full
89 GREENWICH ST	89	GREENWICH	ST	PROVIDENCE	RI	02907	1	Multi-Family	Non-Lead	Lead	8	Private Side Only
50 HAMILTON ST	50	HAMILTON	ST	PROVIDENCE	RI	02907	1	Multi-Family	Non-Lead	Lead	9	Private Side Only
168 HAMILTON ST	168	HAMILTON	ST	PROVIDENCE	RI	02907	1	Multi-Family	Non-Lead	Lead	9	Private Side Only
84 HAMILTON ST	84	HAMILTON	ST	PROVIDENCE	RI	02907	1	Multi-Family	Non-Lead	Lead	9	Private Side Only
138 HAMILTON ST	138	HAMILTON	ST	PROVIDENCE	RI	02907	1	Multi-Family	Non-Lead	Lead	9	Private Side Only
28 HAMILTON ST	28	HAMILTON	ST	PROVIDENCE	RI	02907	1	Single-Family	Non-Lead	Lead	9	Private Side Only
13 HAMILTON ST	13	HAMILTON	ST	PROVIDENCE	RI	02907	1	Multi-Family	Non-Lead	Lead	9	Private Side Only
94 HAMILTON ST	94	HAMILTON	ST	PROVIDENCE	RI	02907	1	Multi-Family	Non-Lead	Lead	9	Private Side Only
8 HAMILTON ST	8	HAMILTON	ST	PROVIDENCE	RI	02907	1	Single-Family	Non-Lead	Lead	9	Private Side Only
92 HAMILTON ST	92	HAMILTON	ST	PROVIDENCE	RI	02907	1	Multi-Family	Non-Lead	Lead	9	Private Side Only
177 HAMILTON ST	177	HAMILTON	ST	PROVIDENCE	RI	02907	1	Single-Family	Non-Lead	Lead	9	Private Side Only
75 HAMILTON ST	75	HAMILTON	ST	PROVIDENCE	RI	02907	1	Multi-Family	Non-Lead	Lead	9	Private Side Only
166 HAMILTON ST	166	HAMILTON	ST	PROVIDENCE	RI	02907	1	Multi-Family	Non-Lead	Lead	9	Private Side Only
56 HAMILTON ST	56	HAMILTON	ST	PROVIDENCE	RI	02907	1	Multi-Family	Non-Lead	Lead	9	Private Side Only
12 HAMILTON ST	12	HAMILTON	ST	PROVIDENCE	RI	02907	1	Single-Family	Non-Lead	Lead	9	Private Side Only
85 HAMILTON ST	85	HAMILTON	ST	PROVIDENCE	RI	02907	1	Multi-Family	Non-Lead	Lead	9	Private Side Only
76 HAMILTON ST	76	HAMILTON	ST	PROVIDENCE	RI	02907	1	Multi-Family	Non-Lead	Lead	9	Private Side Only
99 HAMILTON ST	99	HAMILTON	ST	PROVIDENCE	RI	02907	1	Multi-Family	Non-Lead	Lead	9	Private Side Only
80 HAMILTON ST	80	HAMILTON	ST	PROVIDENCE	RI	02907	1	Single-Family	Non-Lead	Lead	9	Private Side Only

FULL ADDRESS	HOUSE NUMBER	STREET	SUFFIX	CITY	STATE	ZIPCODE	SERVICE DIAMETER	BUILDING TYPE	PUBLIC SIDE MATERIAL	PRIVATE SIDE MATERIAL	WARD	REPLACEMENT TYPE
123 HAMILTON ST	123	HAMILTON	ST	PROVIDENCE	RI	02907	1	Single-Family	Non-Lead	Lead	9	Private Side Only
130 HAMILTON ST	130	HAMILTON	ST	PROVIDENCE	RI	02907	1	Multi-Family	Non-Lead	Lead	9	Private Side Only
118 HAMILTON ST	118	HAMILTON	ST	PROVIDENCE	RI	02907	1	Multi-Family	Non-Lead	Lead	9	Private Side Only
28 HAWTHORNE ST	28	HAWTHORNE	ST	PROVIDENCE	RI	02907	1	Multi-Family	Non-Lead	Lead	8	Private Side Only
2 HAWTHORNE ST	2	HAWTHORNE	ST	PROVIDENCE	RI	02907	1	Non residential	Non-Lead	Lead	8	Private Side Only
27 HAWTHORNE ST	27	HAWTHORNE	ST	PROVIDENCE	RI	02907	1	Multi-Family	Non-Lead	Lead	8	Private Side Only
17 HAWTHORNE ST	17	HAWTHORNE	ST	PROVIDENCE	RI	02907	1	Multi-Family	Non-Lead	Lead	8	Private Side Only
6 HAWTHORNE ST	6	HAWTHORNE	ST	PROVIDENCE	RI	02907	1	Multi-Family	Non-Lead	Lead	8	Private Side Only
20 HAWTHORNE ST	20	HAWTHORNE	ST	PROVIDENCE	RI	02907	1	Single-Family	Non-Lead	Lead	8	Private Side Only
10 HAWTHORNE ST	10	HAWTHORNE	ST	PROVIDENCE	RI	02907	1	Multi-Family	Non-Lead	Lead	8	Private Side Only
12 HAWTHORNE ST	12	HAWTHORNE	ST	PROVIDENCE	RI	02907	1	Multi-Family	Non-Lead	Lead	8	Private Side Only
31 HAWTHORNE ST	31	HAWTHORNE	ST	PROVIDENCE	RI	02907	1	Multi-Family	Non-Lead	Lead	8	Private Side Only
317 HEATHER ST	317	HEATHER	ST	CRANSTON	RI	02920	1	Multi-Family	Non-Lead	Lead	3	Private Side Only
14 KENWOOD ST	14	KENWOOD	ST	PROVIDENCE	RI	02909	1	Multi-Family	Non-Lead	Lead	8	Private Side Only
38 KENWOOD ST	38	KENWOOD	ST	PROVIDENCE	RI	02909	0.625	Single-Family	Lead	Lead	8	Full
34 KENWOOD ST	34	KENWOOD	ST	PROVIDENCE	RI	02909	0.625	Single-Family	Lead	Lead	8	Full
26 KENWOOD ST	26	KENWOOD	ST	PROVIDENCE	RI	02907	0.625	Multi-Family	Lead	Lead	8	Full
48 KENWOOD ST	48	KENWOOD	ST	PROVIDENCE	RI	02909	0.625	Multi-Family	Lead	Lead	8	Full
30 KENWOOD ST	30	KENWOOD	ST	PROVIDENCE	RI	02909	1	Single-Family	Non-Lead	Lead	8	Private Side Only
16 KENWOOD ST	16	KENWOOD	ST	PROVIDENCE	RI	02909	0.625	Multi-Family	Lead	Lead	8	Full
31 KNIGHT ST	31	KNIGHT	ST	CRANSTON	RI	02920	0.625	Multi-Family	Lead	Lead	5	Full
37 KNIGHT ST	37	KNIGHT	ST	CRANSTON	RI	02920	0.625	Single-Family	Lead	Lead	5	Full
11 KNIGHT ST	11	KNIGHT	ST	CRANSTON	RI	02920	0.625	Multi-Family	Lead	Lead	5	Full
75 KNIGHT ST	75	KNIGHT	ST	CRANSTON	RI	02920	0.625	Multi-Family	Lead	Lead	5	Full
12 KNIGHT ST	12	KNIGHT	ST	CRANSTON	RI	02920	0.625	Single-Family	Lead	Lead	5	Full
15 KNIGHT ST	15	KNIGHT	ST	CRANSTON	RI	02920	0.625	Single-Family	Lead	Lead	5	Full
50 KNIGHT ST	50	KNIGHT	ST	CRANSTON	RI	02920	0.625	Multi-Family	Lead	Lead	5	Full
41 KNIGHT ST	41	KNIGHT	ST	CRANSTON	RI	02920	0.625	Multi-Family	Lead	Lead	5	Full
10 KNIGHT ST	10	KNIGHT	ST	CRANSTON	RI	02920	0.625	Multi-Family	Lead	Lead	5	Full
58 LAURA ST	58	LAURA	ST	PROVIDENCE	RI	02907	1	Multi-Family	Non-Lead	Lead	9	Private Side Only
41 LAURA ST	41	LAURA	ST	PROVIDENCE	RI	02907	1	Multi-Family	Non-Lead	Lead	9	Private Side Only
109 LAURA ST	109	LAURA	ST	PROVIDENCE	RI	02907	1	Multi-Family	Non-Lead	Lead	9	Private Side Only
100 LAURA ST	100	LAURA	ST	PROVIDENCE	RI	02907	1	Multi-Family	Non-Lead	Lead	9	Private Side Only
62 LAURA ST	62	LAURA	ST	PROVIDENCE	RI	02907	1	Multi-Family	Non-Lead	Lead	9	Private Side Only
112 LAURA ST	112	LAURA	ST	PROVIDENCE	RI	02907	1	Multi-Family	Non-Lead	Lead	9	Private Side Only
126 LAURA ST	126	LAURA	ST	PROVIDENCE	RI	02907	1	Single-Family	Non-Lead	Lead	9	Private Side Only
140 LAURA ST	140	LAURA	ST	PROVIDENCE	RI	02907	1	Multi-Family	Non-Lead	Lead	9	Private Side Only
19 LAURA ST	19	LAURA	ST	PROVIDENCE	RI	02907	1	Single-Family	Non-Lead	Lead	9	Private Side Only
61 LAURA ST	61	LAURA	ST	PROVIDENCE	RI	02907	1	Multi-Family	Non-Lead	Lead	9	Private Side Only
13 LAURA ST	13	LAURA	ST	PROVIDENCE	RI	02907	1	Multi-Family	Non-Lead	Lead	9	Private Side Only
129 LAURA ST	129	LAURA	ST	PROVIDENCE	RI	02907	1	Multi-Family	Non-Lead	Lead	9	Private Side Only

FULL ADDRESS	HOUSE NUMBER	STREET	SUFFIX	CITY	STATE	ZIPCODE	SERVICE DIAMETER	BUILDING TYPE	PUBLIC SIDE MATERIAL	PRIVATE SIDE MATERIAL	WARD	REPLACEMENT TYPE
48 LAURA ST	48	LAURA	ST	PROVIDENCE	RI	02907	1	Multi-Family	Non-Lead	Lead	9	Private Side Only
103 LAURA ST	103	LAURA	ST	PROVIDENCE	RI	02907	1	Multi-Family	Non-Lead	Lead	9	Private Side Only
116 LAURA ST	116	LAURA	ST	PROVIDENCE	RI	02907	1	Multi-Family	Non-Lead	Lead	9	Private Side Only
127 LAURA ST	127	LAURA	ST	PROVIDENCE	RI	02907	1	Multi-Family	Non-Lead	Lead	9	Private Side Only
35 LAURA ST	35	LAURA	ST	PROVIDENCE	RI	02907	1	Multi-Family	Non-Lead	Lead	9	Private Side Only
122 LAURA ST	122	LAURA	ST	PROVIDENCE	RI	02907	1	Single-Family	Non-Lead	Lead	9	Private Side Only
25 LAURA ST	25	LAURA	ST	PROVIDENCE	RI	02907	1	Multi-Family	Non-Lead	Lead	9	Private Side Only
42 MADISON ST	42	MADISON	ST	PROVIDENCE	RI	02907	1	Multi-Family	Non-Lead	Lead	8	Private Side Only
41 MADISON ST	41	MADISON	ST	PROVIDENCE	RI	02907	1	Single-Family	Non-Lead	Lead	8	Private Side Only
39 MADISON ST	39	MADISON	ST	PROVIDENCE	RI	02907	1	Single-Family	Non-Lead	Lead	8	Private Side Only
34 MADISON ST	34	MADISON	ST	PROVIDENCE	RI	02907	0.625	Multi-Family	Lead	Lead	8	Full
37 MADISON ST	37	MADISON	ST	PROVIDENCE	RI	02907	1	Multi-Family	Non-Lead	Lead	8	Private Side Only
40 MADISON ST	40	MADISON	ST	PROVIDENCE	RI	02907	1	Single-Family	Non-Lead	Lead	8	Private Side Only
33 MADISON ST	33	MADISON	ST	PROVIDENCE	RI	02907	1	Multi-Family	Non-Lead	Lead	8	Private Side Only
20 MADISON ST	20	MADISON	ST	PROVIDENCE	RI	02907	1	Multi-Family	Non-Lead	Lead	8	Private Side Only
47 MAPLE ST	47	MAPLE	ST	CRANSTON	RI	02910	0.75	Multi-Family	Non-Lead	Lead	3	Private Side Only
23 MASSACHUSETTS ST	23	MASSACHUSETTS	ST	CRANSTON	RI	02920	0.625	Single-Family	Lead	Lead	5	Full
33 MASSACHUSETTS ST	33	MASSACHUSETTS	ST	CRANSTON	RI	02920	0.625	Multi-Family	Lead	Lead	5	Full
25 MATHEWSON ST	25	MATHEWSON	ST	CRANSTON	RI	02920	0.625	Multi-Family	Lead	Lead	5	Full
46 MATHEWSON ST	46	MATHEWSON	ST	CRANSTON	RI	02920	0.625	Single-Family	Lead	Lead	5	Full
37 MATHEWSON ST	37	MATHEWSON	ST	CRANSTON	RI	02920	0.625	Multi-Family	Lead	Lead	5	Full
122 MAWNEY ST	122	MAWNEY	ST	PROVIDENCE	RI	02907	0.625	Multi-Family	Lead	Lead	8	Full
94 MAWNEY ST	94	MAWNEY	ST	PROVIDENCE	RI	02907	0.75	Multi-Family	Non-Lead	Lead	8	Private Side Only
70 MAWNEY ST	70	MAWNEY	ST	PROVIDENCE	RI	02907	0.75	Multi-Family	Lead	Lead	8	Full
120 MAWNEY ST	120	MAWNEY	ST	PROVIDENCE	RI	02907	0.625	Multi-Family	Lead	Lead	8	Full
78 MAWNEY ST	78	MAWNEY	ST	PROVIDENCE	RI	02907	0.625	Multi-Family	Lead	Lead	8	Full
114 MAWNEY ST	114	MAWNEY	ST	PROVIDENCE	RI	02907	0.625	Multi-Family	Lead	Lead	8	Full
108 MAWNEY ST	108	MAWNEY	ST	PROVIDENCE	RI	02907	0.625	Multi-Family	Lead	Lead	8	Full
126 MAWNEY ST	126	MAWNEY	ST	PROVIDENCE	RI	02907	0.625	Multi-Family	Lead	Lead	8	Full
106 MAWNEY ST	106	MAWNEY	ST	PROVIDENCE	RI	02907	0.625	Multi-Family	Lead	Lead	8	Full
114 MELROSE ST	114	MELROSE	ST	PROVIDENCE	RI	02907	1	Multi-Family	Non-Lead	Lead	9	Private Side Only
90 MELROSE ST	90	MELROSE	ST	PROVIDENCE	RI	02907	1	Multi-Family	Non-Lead	Lead	9	Private Side Only
110 MELROSE ST	110	MELROSE	ST	PROVIDENCE	RI	02907	1	Single-Family	Non-Lead	Lead	9	Private Side Only
84 MELROSE ST	84	MELROSE	ST	PROVIDENCE	RI	02907	1	Single-Family	Non-Lead	Lead	9	Private Side Only
78 MELROSE ST	78	MELROSE	ST	PROVIDENCE	RI	02907	0.625	Multi-Family	Lead	Lead	9	Full
102 MELROSE ST	102	MELROSE	ST	PROVIDENCE	RI	02907	1	Single-Family	Non-Lead	Lead	9	Private Side Only
118 MELROSE ST	118	MELROSE	ST	PROVIDENCE	RI	02907	1	Multi-Family	Non-Lead	Lead	9	Private Side Only
126 MELROSE ST	126	MELROSE	ST	PROVIDENCE	RI	02907	1	Multi-Family	Non-Lead	Lead	9	Private Side Only
92 MELROSE ST	92	MELROSE	ST	PROVIDENCE	RI	02907	1	Single-Family	Non-Lead	Lead	9	Private Side Only
132 MERCY ST	132	MERCY	ST	PROVIDENCE	RI	02909	0.625	Single-Family	Lead	Lead	7	Full
165 MERCY ST	165	MERCY	ST	PROVIDENCE	RI	02909	0.625	Multi-Family	Lead	Lead	7	Full

FULL ADDRESS	HOUSE NUMBER	STREET	SUFFIX	CITY	STATE	ZIPCODE	SERVICE DIAMETER	BUILDING TYPE	PUBLIC SIDE MATERIAL	PRIVATE SIDE MATERIAL	WARD	REPLACEMENT TYPE
177 MESSER ST	177	MESSER	ST	PROVIDENCE	RI	02909	0.625	Multi-Family	Lead	Lead	15	Full
194 MESSER ST	194	MESSER	ST	PROVIDENCE	RI	02909	1	Multi-Family	Non-Lead	Lead	15	Private Side Only
217 MESSER ST	217	MESSER	ST	PROVIDENCE	RI	02909	1	Multi-Family	Non-Lead	Lead	8	Private Side Only
200 MESSER ST	200	MESSER	ST	PROVIDENCE	RI	02909	1	Multi-Family	Non-Lead	Lead	15	Private Side Only
161 MESSER ST	161	MESSER	ST	PROVIDENCE	RI	02909	0.75	Multi-Family	Non-Lead	Lead	15	Private Side Only
206 MESSER ST	206	MESSER	ST	PROVIDENCE	RI	02909	1	Multi-Family	Non-Lead	Lead	15	Private Side Only
204 MESSER ST	204	MESSER	ST	PROVIDENCE	RI	02909	1	Mixed Residential & Nonresidential	Non-Lead	Lead	15	Private Side Only
187 MESSER ST	187	MESSER	ST	PROVIDENCE	RI	02909	1	Non residential	Non-Lead	Lead	15	Private Side Only
223 MESSER ST	223	MESSER	ST	PROVIDENCE	RI	02909	1	Multi-Family	Non-Lead	Lead	8	Private Side Only
227 MESSER ST	227	MESSER	ST	PROVIDENCE	RI	02909	1	Multi-Family	Non-Lead	Lead	8	Private Side Only
98 MITCHELL ST	98	MITCHELL	ST	PROVIDENCE	RI	02907	0.75	Single-Family	Non-Lead	Lead	9	Private Side Only
102 MITCHELL ST	102	MITCHELL	ST	PROVIDENCE	RI	02907	1	Multi-Family	Non-Lead	Lead	9	Private Side Only
71 MITCHELL ST	71	MITCHELL	ST	PROVIDENCE	RI	02907	1	Multi-Family	Non-Lead	Lead	9	Private Side Only
63 MITCHELL ST	63	MITCHELL	ST	PROVIDENCE	RI	02907	1	Multi-Family	Non-Lead	Lead	9	Private Side Only
75 MITCHELL ST	75	MITCHELL	ST	PROVIDENCE	RI	02907	1	Multi-Family	Non-Lead	Lead	9	Private Side Only
128 MITCHELL ST	128	MITCHELL	ST	PROVIDENCE	RI	02907	1	Multi-Family	Non-Lead	Lead	9	Private Side Only
112 MITCHELL ST	112	MITCHELL	ST	PROVIDENCE	RI	02907	1	Multi-Family	Non-Lead	Lead	9	Private Side Only
54 MITCHELL ST	54	MITCHELL	ST	PROVIDENCE	RI	02907	1	Multi-Family	Non-Lead	Lead	9	Private Side Only
106 MITCHELL ST	106	MITCHELL	ST	PROVIDENCE	RI	02907	1	Multi-Family	Non-Lead	Lead	9	Private Side Only
97 MITCHELL ST	97	MITCHELL	ST	PROVIDENCE	RI	02907	1	Multi-Family	Non-Lead	Lead	9	Private Side Only
64 MITCHELL ST	64	MITCHELL	ST	PROVIDENCE	RI	02907	1	Multi-Family	Non-Lead	Lead	9	Private Side Only
74 MITCHELL ST	74	MITCHELL	ST	PROVIDENCE	RI	02907	1	Single-Family	Non-Lead	Lead	9	Private Side Only
62 MITCHELL ST	62	MITCHELL	ST	PROVIDENCE	RI	02907	1	Multi-Family	Non-Lead	Lead	9	Private Side Only
45 MITCHELL ST	45	MITCHELL	ST	PROVIDENCE	RI	02907	1	Multi-Family	Non-Lead	Lead	9	Private Side Only
59 MITCHELL ST	59	MITCHELL	ST	PROVIDENCE	RI	02907	1	Multi-Family	Non-Lead	Lead	9	Private Side Only
36 MITCHELL ST	36	MITCHELL	ST	PROVIDENCE	RI	02907	1	Multi-Family	Non-Lead	Lead	9	Private Side Only
58 MITCHELL ST	58	MITCHELL	ST	PROVIDENCE	RI	02907	1	Single-Family	Non-Lead	Lead	9	Private Side Only
131 MITCHELL ST	131	MITCHELL	ST	PROVIDENCE	RI	02907	1	Multi-Family	Non-Lead	Lead	9	Private Side Only
13 MOOREFIELD ST	13	MOOREFIELD	ST	PROVIDENCE	RI	02909	0.625	Multi-Family	Lead	Lead	7	Full
22 MOOREFIELD ST	22	MOOREFIELD	ST	PROVIDENCE	RI	02909	0.625	Multi-Family	Lead	Lead	7	Full
29 MOOREFIELD ST	29	MOOREFIELD	ST	PROVIDENCE	RI	02909	0.625	Multi-Family	Lead	Lead	7	Full
16 MOOREFIELD ST	16	MOOREFIELD	ST	PROVIDENCE	RI	02909	0.625	Single-Family	Lead	Lead	7	Full
50 MOOREFIELD ST	50	MOOREFIELD	ST	PROVIDENCE	RI	02909	0.625	Multi-Family	Lead	Lead	7	Full
28 MOOREFIELD ST	28	MOOREFIELD	ST	PROVIDENCE	RI	02909	0.625	Multi-Family	Lead	Lead	7	Full
17 MOOREFIELD ST	17	MOOREFIELD	ST	PROVIDENCE	RI	02909	0.625	Single-Family	Lead	Lead	7	Full
48 MOOREFIELD ST	48	MOOREFIELD	ST	PROVIDENCE	RI	02909	0.625	Multi-Family	Lead	Lead	7	Full
54 MOOREFIELD ST	54	MOOREFIELD	ST	PROVIDENCE	RI	02909	0.625	Multi-Family	Lead	Lead	7	Full
33 MOOREFIELD ST	33	MOOREFIELD	ST	PROVIDENCE	RI	02909	0.625	Multi-Family	Lead	Lead	7	Full
7 MOOREFIELD ST	7	MOOREFIELD	ST	PROVIDENCE	RI	02909	0.625	Multi-Family	Lead	Lead	7	Full
21 MOOREFIELD ST	21	MOOREFIELD	ST	PROVIDENCE	RI	02909	0.625	Multi-Family	Lead	Lead	7	Full
12 MOOREFIELD ST	12	MOOREFIELD	ST	PROVIDENCE	RI	02909	0.625	Single-Family	Lead	Lead	7	Full

FULL ADDRESS	HOUSE NUMBER	STREET	SUFFIX	CITY	STATE	ZIPCODE	SERVICE DIAMETER	BUILDING TYPE	PUBLIC SIDE MATERIAL	PRIVATE SIDE MATERIAL	WARD	REPLACEMENT TYPE
36 MOOREFIELD ST	36	MOOREFIELD	ST	PROVIDENCE	RI	02909	0.625	Multi-Family	Lead	Lead	7	Full
124 MURRAY ST	124	MURRAY	ST	PROVIDENCE	RI	02909	0.625	Multi-Family	Lead	Lead	7	Full
108 MURRAY ST	108	MURRAY	ST	PROVIDENCE	RI	02909	0.625	Multi-Family	Lead	Lead	7	Full
120 MURRAY ST	120	MURRAY	ST	PROVIDENCE	RI	02909	0.625	Multi-Family	Lead	Lead	7	Full
121 MURRAY ST	121	MURRAY	ST	PROVIDENCE	RI	02909	0.625	Multi-Family	Lead	Non-Lead	7	Public Side Only
141 MURRAY ST	141	MURRAY	ST	PROVIDENCE	RI	02909	1	Multi-Family	Non-Lead	Lead	7	Private Side Only
139 MURRAY ST	139	MURRAY	ST	PROVIDENCE	RI	02909	0.625	Multi-Family	Lead	Lead	7	Full
129 MURRAY ST	129	MURRAY	ST	PROVIDENCE	RI	02909	0.625	Multi-Family	Lead	Lead	7	Full
113 NIAGARA ST	113	NIAGARA	ST	PROVIDENCE	RI	02907	1	Single-Family	Non-Lead	Lead	9	Private Side Only
172 NIAGARA ST	172	NIAGARA	ST	PROVIDENCE	RI	02907	1	Multi-Family	Non-Lead	Lead	9	Private Side Only
127 NIAGARA ST	127	NIAGARA	ST	PROVIDENCE	RI	02907	1	Multi-Family	Non-Lead	Lead	9	Private Side Only
163 NIAGARA ST	163	NIAGARA	ST	PROVIDENCE	RI	02907	1	Multi-Family	Non-Lead	Lead	9	Private Side Only
100 NIAGARA ST	100	NIAGARA	ST	PROVIDENCE	RI	02907	1	Non residential	Non-Lead	Lead	9	Private Side Only
121 NIAGARA ST	121	NIAGARA	ST	PROVIDENCE	RI	02907	1	Multi-Family	Non-Lead	Lead	9	Private Side Only
117 NIAGARA ST	117	NIAGARA	ST	PROVIDENCE	RI	02907	1	Single-Family	Non-Lead	Lead	9	Private Side Only
81 NIAGARA ST	81	NIAGARA	ST	PROVIDENCE	RI	02907	1	Multi-Family	Non-Lead	Lead	9	Private Side Only
65 NIAGARA ST	65	NIAGARA	ST	PROVIDENCE	RI	02907	1	Multi-Family	Non-Lead	Lead	9	Private Side Only
45 OAK ST	45	OAK	ST	CRANSTON	RI	02910	0.75	Multi-Family	Non-Lead	Lead	3	Private Side Only
25 OAK ST	25	OAK	ST	CRANSTON	RI	02910	0.75	Multi-Family	Non-Lead	Lead	3	Private Side Only
29 OAK ST	29	OAK	ST	CRANSTON	RI	02910	0.75	Multi-Family	Lead	Lead	3	Full
69 ONTARIO ST	69	ONTARIO	ST	PROVIDENCE	RI	02907	1	Multi-Family	Non-Lead	Lead	9	Private Side Only
120 ONTARIO ST	120	ONTARIO	ST	PROVIDENCE	RI	02907	1	Single-Family	Non-Lead	Lead	9	Private Side Only
82 ONTARIO ST	82	ONTARIO	ST	PROVIDENCE	RI	02907	1	Multi-Family	Non-Lead	Lead	9	Private Side Only
119 ONTARIO ST	119	ONTARIO	ST	PROVIDENCE	RI	02907	1	Multi-Family	Non-Lead	Lead	9	Private Side Only
70 ONTARIO ST	70	ONTARIO	ST	PROVIDENCE	RI	02907	1	Multi-Family	Non-Lead	Lead	9	Private Side Only
129 ONTARIO ST	129	ONTARIO	ST	PROVIDENCE	RI	02907	1	Multi-Family	Non-Lead	Lead	9	Private Side Only
66 ONTARIO ST	66	ONTARIO	ST	PROVIDENCE	RI	02907	1	Multi-Family	Non-Lead	Lead	9	Private Side Only
193 ONTARIO ST	193	ONTARIO	ST	PROVIDENCE	RI	02907	1.5	Multi-Family	Non-Lead	Lead	9	Private Side Only
179 ONTARIO ST	179	ONTARIO	ST	PROVIDENCE	RI	02907	1	Multi-Family	Non-Lead	Lead	9	Private Side Only
111 ONTARIO ST	111	ONTARIO	ST	PROVIDENCE	RI	02907	1	Multi-Family	Non-Lead	Lead	9	Private Side Only
62 ONTARIO ST	62	ONTARIO	ST	PROVIDENCE	RI	02907	1	Multi-Family	Non-Lead	Lead	9	Private Side Only
202 ONTARIO ST	202	ONTARIO	ST	PROVIDENCE	RI	02907	1	Multi-Family	Non-Lead	Lead	9	Private Side Only
61 ONTARIO ST	61	ONTARIO	ST	PROVIDENCE	RI	02907	1	Single-Family	Non-Lead	Lead	9	Private Side Only
65 ONTARIO ST	65	ONTARIO	ST	PROVIDENCE	RI	02907	1	Multi-Family	Non-Lead	Lead	9	Private Side Only
75 ONTARIO ST	75	ONTARIO	ST	PROVIDENCE	RI	02907	1	Multi-Family	Non-Lead	Lead	9	Private Side Only
128 ONTARIO ST	128	ONTARIO	ST	PROVIDENCE	RI	02907	1	Single-Family	Non-Lead	Lead	9	Private Side Only
86 ONTARIO ST	86	ONTARIO	ST	PROVIDENCE	RI	02907	1	Multi-Family	Non-Lead	Lead	9	Private Side Only
166 ONTARIO ST	166	ONTARIO	ST	PROVIDENCE	RI	02907	1	Single-Family	Non-Lead	Lead	9	Private Side Only
195 ONTARIO ST	195	ONTARIO	ST	PROVIDENCE	RI	02907	1	Multi-Family	Non-Lead	Lead	9	Private Side Only
169 ONTARIO ST	169	ONTARIO	ST	PROVIDENCE	RI	02907	1	Multi-Family	Non-Lead	Lead	9	Private Side Only
199 ONTARIO ST	199	ONTARIO	ST	PROVIDENCE	RI	02907	1	Single-Family	Non-Lead	Lead	9	Private Side Only

FULL ADDRESS	HOUSE NUMBER	STREET	SUFFIX	CITY	STATE	ZIPCODE	SERVICE DIAMETER	BUILDING TYPE	PUBLIC SIDE MATERIAL	PRIVATE SIDE MATERIAL	WARD	REPLACEMENT TYPE
127 ONTARIO ST	127	ONTARIO	ST	PROVIDENCE	RI	02907	1	Single-Family	Non-Lead	Lead	9	Private Side Only
175 ONTARIO ST	175	ONTARIO	ST	PROVIDENCE	RI	02907	1	Single-Family	Non-Lead	Lead	9	Private Side Only
78 ONTARIO ST	78	ONTARIO	ST	PROVIDENCE	RI	02907	1	Multi-Family	Non-Lead	Lead	9	Private Side Only
81 ONTARIO ST	81	ONTARIO	ST	PROVIDENCE	RI	02907	1	Multi-Family	Non-Lead	Lead	9	Private Side Only
176 ONTARIO ST	176	ONTARIO	ST	PROVIDENCE	RI	02907	1	Single-Family	Non-Lead	Lead	9	Private Side Only
140 ONTARIO ST	140	ONTARIO	ST	PROVIDENCE	RI	02907	1	Multi-Family	Non-Lead	Lead	9	Private Side Only
180 ONTARIO ST	180	ONTARIO	ST	PROVIDENCE	RI	02907	1	Multi-Family	Non-Lead	Lead	9	Private Side Only
172 ONTARIO ST	172	ONTARIO	ST	PROVIDENCE	RI	02907	1	Single-Family	Non-Lead	Lead	9	Private Side Only
149 PEACE ST	149	PEACE	ST	PROVIDENCE	RI	02907	0.625	Multi-Family	Lead	Lead	8	Full
172 PEACE ST	172	PEACE	ST	PROVIDENCE	RI	02907	0.625	Multi-Family	Lead	Lead	8	Full
156 PEACE ST	156	PEACE	ST	PROVIDENCE	RI	02907	0.625	Multi-Family	Lead	Lead	8	Full
173 PEACE ST	173	PEACE	ST	PROVIDENCE	RI	02907	0.625	Multi-Family	Lead	Lead	8	Full
177 PEACE ST	177	PEACE	ST	PROVIDENCE	RI	02907	0.625	Multi-Family	Lead	Lead	8	Full
169 PEACE ST	169	PEACE	ST	PROVIDENCE	RI	02907	0.75	Multi-Family	Lead	Lead	8	Full
189 PEACE ST	189	PEACE	ST	PROVIDENCE	RI	02907	0.625	Multi-Family	Lead	Lead	8	Full
146 PEACE ST	146	PEACE	ST	PROVIDENCE	RI	02907	0.625	Single-Family	Lead	Non-Lead	8	Public Side Only
153 PEACE ST	153	PEACE	ST	PROVIDENCE	RI	02907	1	Single-Family	Non-Lead	Lead	8	Private Side Only
196 PEACE ST	196	PEACE	ST	PROVIDENCE	RI	02907	0.75	Multi-Family	Lead	Lead	8	Full
186 PEACE ST	186	PEACE	ST	PROVIDENCE	RI	02907	0.625	Multi-Family	Lead	Lead	8	Full
161 PEACE ST	161	PEACE	ST	PROVIDENCE	RI	02907	0.625	Single-Family	Lead	Lead	8	Full
178 PEACE ST	178	PEACE	ST	PROVIDENCE	RI	02907	0.625	Multi-Family	Lead	Lead	8	Full
166 PEACE ST	166	PEACE	ST	PROVIDENCE	RI	02907	0.625	Single-Family	Lead	Lead	8	Full
195 PEACE ST	195	PEACE	ST	PROVIDENCE	RI	02907	0.75	Multi-Family	Lead	Lead	8	Full
193 PEACE ST	193	PEACE	ST	PROVIDENCE	RI	02907	0.625	Multi-Family	Lead	Lead	8	Full
182 PEACE ST	182	PEACE	ST	PROVIDENCE	RI	02907	0.625	Multi-Family	Lead	Lead	8	Full
157 PEACE ST	157	PEACE	ST	PROVIDENCE	RI	02907	0.625	Multi-Family	Lead	Lead	8	Full
7 PINE ST	7	PINE	ST	CRANSTON	RI	02910	0.75	Single-Family	Non-Lead	Lead	3	Private Side Only
54 PLYMOUTH ST	54	PLYMOUTH	ST	PROVIDENCE	RI	02907	1	Single-Family	Non-Lead	Lead	8	Private Side Only
50 PLYMOUTH ST	50	PLYMOUTH	ST	PROVIDENCE	RI	02907	1	Single-Family	Non-Lead	Lead	8	Private Side Only
77 PRUDENCE ST	77	PRUDENCE	ST	PROVIDENCE	RI	02909	0.625	Non residential	Lead	Lead	7	Full
606 PUBLIC ST	606	PUBLIC	ST	PROVIDENCE	RI	02907	1	Single-Family	Non-Lead	Lead	9	Private Side Only
648 PUBLIC ST	648	PUBLIC	ST	PROVIDENCE	RI	02907	1	Multi-Family	Non-Lead	Lead	9	Private Side Only
676 PUBLIC ST	676	PUBLIC	ST	PROVIDENCE	RI	02907	1	Multi-Family	Non-Lead	Lead	9	Private Side Only
600 PUBLIC ST	600	PUBLIC	ST	PROVIDENCE	RI	02907	1	Multi-Family	Non-Lead	Lead	9	Private Side Only
616 PUBLIC ST	616	PUBLIC	ST	PROVIDENCE	RI	02907	0.625	Multi-Family	Lead	Lead	9	Full
658 PUBLIC ST	658	PUBLIC	ST	PROVIDENCE	RI	02907	1	Multi-Family	Non-Lead	Lead	9	Private Side Only
690 PUBLIC ST	690	PUBLIC	ST	PROVIDENCE	RI	02907	1	Non residential	Non-Lead	Lead	9	Private Side Only
680 PUBLIC ST	680	PUBLIC	ST	PROVIDENCE	RI	02907	1	Multi-Family	Non-Lead	Lead	9	Private Side Only
590 PUBLIC ST	590	PUBLIC	ST	PROVIDENCE	RI	02907	1	Multi-Family	Non-Lead	Lead	9	Private Side Only
572 PUBLIC ST	572	PUBLIC	ST	PROVIDENCE	RI	02907	1	Multi-Family	Non-Lead	Lead	9	Private Side Only
612 PUBLIC ST	612	PUBLIC	ST	PROVIDENCE	RI	02907	1	Multi-Family	Non-Lead	Lead	9	Private Side Only

FULL ADDRESS	HOUSE NUMBER	STREET	SUFFIX	CITY	STATE	ZIPCODE	SERVICE DIAMETER	BUILDING TYPE	PUBLIC SIDE MATERIAL	PRIVATE SIDE MATERIAL	WARD	REPLACEMENT TYPE
560 PUBLIC ST	560	PUBLIC	ST	PROVIDENCE	RI	02907	1	Multi-Family	Non-Lead	Lead	9	Private Side Only
628 PUBLIC ST	628	PUBLIC	ST	PROVIDENCE	RI	02907	1	Single-Family	Non-Lead	Lead	9	Private Side Only
566 PUBLIC ST	566	PUBLIC	ST	PROVIDENCE	RI	02907	1	Multi-Family	Non-Lead	Lead	9	Private Side Only
652 PUBLIC ST	652	PUBLIC	ST	PROVIDENCE	RI	02907	1	Multi-Family	Non-Lead	Lead	9	Private Side Only
640 PUBLIC ST	640	PUBLIC	ST	PROVIDENCE	RI	02907	1	Single-Family	Non-Lead	Lead	9	Private Side Only
594 PUBLIC ST	594	PUBLIC	ST	PROVIDENCE	RI	02907	1	Multi-Family	Non-Lead	Lead	9	Private Side Only
582 PUBLIC ST	582	PUBLIC	ST	PROVIDENCE	RI	02907	1	Multi-Family	Non-Lead	Lead	9	Private Side Only
54 PURITAN ST	54	PURITAN	ST	PROVIDENCE	RI	02907	1	Single-Family	Non-Lead	Lead	8	Private Side Only
24 PURITAN ST	24	PURITAN	ST	PROVIDENCE	RI	02907	1	Multi-Family	Non-Lead	Lead	8	Private Side Only
43 PURITAN ST	43	PURITAN	ST	PROVIDENCE	RI	02907	1	Single-Family	Non-Lead	Lead	8	Private Side Only
13 PURITAN ST	13	PURITAN	ST	PROVIDENCE	RI	02907	1	Single-Family	Non-Lead	Lead	8	Private Side Only
48 PURITAN ST	48	PURITAN	ST	PROVIDENCE	RI	02907	1	Single-Family	Non-Lead	Lead	8	Private Side Only
40 PURITAN ST	40	PURITAN	ST	PROVIDENCE	RI	02907	1	Single-Family	Non-Lead	Lead	8	Private Side Only
29 RANDALL ST	29	RANDALL	ST	CRANSTON	RI	02920	0.625	Multi-Family	Lead	Lead	5	Full
54 RANDALL ST	54	RANDALL	ST	CRANSTON	RI	02920	0.625	Multi-Family	Lead	Lead	5	Full
44 RANDALL ST	44	RANDALL	ST	CRANSTON	RI	02920	0.75	Multi-Family	Non-Lead	Lead	5	Private Side Only
106 RANDALL ST	106	RANDALL	ST	CRANSTON	RI	02920	0.625	Multi-Family	Lead	Non-Lead	5	Public Side Only
45 RANDALL ST	45	RANDALL	ST	CRANSTON	RI	02920	0.625	Single-Family	Lead	Lead	5	Full
94 RANDALL ST	94	RANDALL	ST	CRANSTON	RI	02920	0.75	Single-Family	Non-Lead	Lead	5	Private Side Only
97 RANDALL ST	97	RANDALL	ST	CRANSTON	RI	02920	0.625	Multi-Family	Lead	Lead	5	Full
23 RANDALL ST	23	RANDALL	ST	CRANSTON	RI	02920	0.625	Multi-Family	Lead	Lead	5	Full
10 RANDALL ST	10	RANDALL	ST	CRANSTON	RI	02920	0.625	Single-Family	Lead	Lead	5	Full
22 RANDALL ST	22	RANDALL	ST	CRANSTON	RI	02920	0.625	Multi-Family	Lead	Lead	5	Full
19 RANDALL ST	19	RANDALL	ST	CRANSTON	RI	02920	0.625	Multi-Family	Lead	Lead	5	Full
34 RANDALL ST	34	RANDALL	ST	CRANSTON	RI	02920	1	Single-Family	Non-Lead	Lead	5	Private Side Only
49 RANDALL ST	49	RANDALL	ST	CRANSTON	RI	02920	0.625	Single-Family	Lead	Non-Lead	5	Public Side Only
74 RANDALL ST	74	RANDALL	ST	CRANSTON	RI	02920	0.625	Multi-Family	Lead	Lead	5	Full
43 RANDALL ST	43	RANDALL	ST	CRANSTON	RI	02920	0.625	Single-Family	Lead	Lead	5	Full
57 REDWING ST	57	REDWING	ST	PROVIDENCE	RI	02907	1	Multi-Family	Non-Lead	Lead	8	Private Side Only
33 REDWING ST	33	REDWING	ST	PROVIDENCE	RI	02907	1	Multi-Family	Non-Lead	Lead	8	Private Side Only
21 REDWING ST	21	REDWING	ST	PROVIDENCE	RI	02907	1	Single-Family	Non-Lead	Lead	8	Private Side Only
7 REDWING ST	7	REDWING	ST	PROVIDENCE	RI	02907	1	Multi-Family	Non-Lead	Lead	8	Private Side Only
42 REDWING ST	42	REDWING	ST	PROVIDENCE	RI	02907	1	Multi-Family	Non-Lead	Lead	8	Private Side Only
14 REDWING ST	14	REDWING	ST	PROVIDENCE	RI	02907	1	Single-Family	Non-Lead	Lead	8	Private Side Only
50 REDWING ST	50	REDWING	ST	PROVIDENCE	RI	02907	0.75	Single-Family	Non-Lead	Lead	8	Private Side Only
46 REDWING ST	46	REDWING	ST	PROVIDENCE	RI	02907	1	Single-Family	Non-Lead	Lead	8	Private Side Only
19 REDWING ST	19	REDWING	ST	PROVIDENCE	RI	02907	1	Multi-Family	Non-Lead	Lead	8	Private Side Only
63 ROSE ST	63	ROSE	ST	CRANSTON	RI	02920	0.625	Multi-Family	Lead	Lead	5	Full
33 ROSE ST	33	ROSE	ST	CRANSTON	RI	02920	0.625	Multi-Family	Lead	Lead	5	Full
37 ROSE ST	37	ROSE	ST	CRANSTON	RI	02920	0.625	Single-Family	Lead	Lead	5	Full
51 ROSE ST	51	ROSE	ST	CRANSTON	RI	02920	0.625	Single-Family	Lead	Lead	5	Full

FULL ADDRESS	HOUSE NUMBER	STREET	SUFFIX	CITY	STATE	ZIPCODE	SERVICE DIAMETER	BUILDING TYPE	PUBLIC SIDE MATERIAL	PRIVATE SIDE MATERIAL	WARD	REPLACEMENT TYPE
6 ROSE ST	6	ROSE	ST	CRANSTON	RI	02920	0.625	Single-Family	Lead	Lead	5	Full
14 ROSE ST	14	ROSE	ST	CRANSTON	RI	02920	0.75	Multi-Family	Lead	Lead	5	Full
29 ROSE ST	29	ROSE	ST	CRANSTON	RI	02920	0.625	Single-Family	Lead	Lead	5	Full
34 ROSEDALE ST	34	ROSEDALE	ST	PROVIDENCE	RI	02909	0.625	Single-Family	Lead	Lead	15	Full
15 ROSEDALE ST	15	ROSEDALE	ST	PROVIDENCE	RI	02909	0.625	Multi-Family	Lead	Lead	15	Full
47 ROSEDALE ST	47	ROSEDALE	ST	PROVIDENCE	RI	02909	1	Multi-Family	Non-Lead	Lead	15	Private Side Only
59 ROSEDALE ST	59	ROSEDALE	ST	PROVIDENCE	RI	02909	0.625	Multi-Family	Lead	Lead	15	Full
49 ROSEDALE ST	49	ROSEDALE	ST	PROVIDENCE	RI	02909	0.625	Multi-Family	Lead	Lead	15	Full
61 ROSEDALE ST	61	ROSEDALE	ST	PROVIDENCE	RI	02909	0.625	Multi-Family	Lead	Lead	15	Full
19 ROSEDALE ST	19	ROSEDALE	ST	PROVIDENCE	RI	02909	0.625	Multi-Family	Lead	Lead	15	Full
44 ROSEDALE ST	44	ROSEDALE	ST	PROVIDENCE	RI	02909	0.625	Multi-Family	Lead	Lead	15	Full
43 ROSEDALE ST	43	ROSEDALE	ST	PROVIDENCE	RI	02909	0.625	Multi-Family	Lead	Non-Lead	15	Public Side Only
62 ROSEDALE ST	62	ROSEDALE	ST	PROVIDENCE	RI	02909	0.625	Single-Family	Lead	Lead	15	Full
33 ROSEDALE ST	33	ROSEDALE	ST	PROVIDENCE	RI	02909	0.75	Multi-Family	Lead	Lead	15	Full
25 ROSEDALE ST	25	ROSEDALE	ST	PROVIDENCE	RI	02909	0.625	Multi-Family	Lead	Lead	15	Full
18 ROSEDALE ST	18	ROSEDALE	ST	PROVIDENCE	RI	02909	0.625	Multi-Family	Lead	Lead	15	Full
22 ROSEDALE ST	22	ROSEDALE	ST	PROVIDENCE	RI	02909	0.625	Single-Family	Lead	Lead	15	Full
11 ROSEDALE ST	11	ROSEDALE	ST	PROVIDENCE	RI	02909	0.625	Multi-Family	Lead	Lead	15	Full
70 ROSEDALE ST	70	ROSEDALE	ST	PROVIDENCE	RI	02909	0.625	Multi-Family	Lead	Lead	15	Full
46 ROSEDALE ST	46	ROSEDALE	ST	PROVIDENCE	RI	02909	0.625	Multi-Family	Lead	Lead	15	Full
52 ROSEDALE ST	52	ROSEDALE	ST	PROVIDENCE	RI	02909	0.625	Multi-Family	Lead	Lead	15	Full
38 ROSEDALE ST	38	ROSEDALE	ST	PROVIDENCE	RI	02909	1	Multi-Family	Non-Lead	Lead	15	Private Side Only
55 ROSEDALE ST	55	ROSEDALE	ST	PROVIDENCE	RI	02909	0.625	Multi-Family	Lead	Lead	15	Full
58 ROSEDALE ST	58	ROSEDALE	ST	PROVIDENCE	RI	02909	0.625	Multi-Family	Lead	Lead	15	Full
65 ROSEDALE ST	65	ROSEDALE	ST	PROVIDENCE	RI	02909	0.625	Multi-Family	Lead	Lead	15	Full
15 RUTLAND ST	15	RUTLAND	ST	PROVIDENCE	RI	02907	1	Multi-Family	Non-Lead	Lead	8	Private Side Only
24 RUTLAND ST	24	RUTLAND	ST	PROVIDENCE	RI	02907	1	Multi-Family	Non-Lead	Lead	8	Private Side Only
16 RUTLAND ST	16	RUTLAND	ST	PROVIDENCE	RI	02907	1	Multi-Family	Non-Lead	Lead	8	Private Side Only
11 RUTLAND ST	11	RUTLAND	ST	PROVIDENCE	RI	02907	1	Multi-Family	Non-Lead	Lead	8	Private Side Only
47 SEABURY ST	47	SEABURY	ST	PROVIDENCE	RI	02907	1	Single-Family	Non-Lead	Lead	8	Private Side Only
41 SEABURY ST	41	SEABURY	ST	PROVIDENCE	RI	02907	1	Single-Family	Non-Lead	Lead	8	Private Side Only
22 SEABURY ST	22	SEABURY	ST	PROVIDENCE	RI	02907	1	Multi-Family	Non-Lead	Lead	8	Private Side Only
37 SEABURY ST	37	SEABURY	ST	PROVIDENCE	RI	02907	1	Single-Family	Non-Lead	Lead	8	Private Side Only
48 SEABURY ST	48	SEABURY	ST	PROVIDENCE	RI	02907	1	Single-Family	Non-Lead	Lead	8	Private Side Only
26 SEABURY ST	26	SEABURY	ST	PROVIDENCE	RI	02907	1	Multi-Family	Non-Lead	Lead	8	Private Side Only
41 SHERWOOD ST	41	SHERWOOD	ST	CRANSTON	RI	02920	0.625	Multi-Family	Lead	Lead	5	Full
63 SHERWOOD ST	63	SHERWOOD	ST	CRANSTON	RI	02920	1	Multi-Family	Non-Lead	Lead	5	Private Side Only
24 SHERWOOD ST	24	SHERWOOD	ST	CRANSTON	RI	02920	0.625	Single-Family	Lead	Lead	5	Full
81 SHERWOOD ST	81	SHERWOOD	ST	CRANSTON	RI	02920	0.625	Single-Family	Lead	Lead	5	Full
16 SHERWOOD ST	16	SHERWOOD	ST	CRANSTON	RI	02920	0.625	Multi-Family	Lead	Lead	5	Full
53 SHERWOOD ST	53	SHERWOOD	ST	CRANSTON	RI	02920	0.625	Multi-Family	Lead	Lead	5	Full

FULL ADDRESS	HOUSE NUMBER	STREET	SUFFIX	CITY	STATE	ZIPCODE	SERVICE DIAMETER	BUILDING TYPE	PUBLIC SIDE MATERIAL	PRIVATE SIDE MATERIAL	WARD	REPLACEMENT TYPE
65 SHERWOOD ST	65	SHERWOOD	ST	CRANSTON	RI	02920	0.625	Single-Family	Lead	Lead	5	Full
50 SHERWOOD ST	50	SHERWOOD	ST	CRANSTON	RI	02920	0.625	Single-Family	Lead	Lead	5	Full
40 SHERWOOD ST	40	SHERWOOD	ST	CRANSTON	RI	02920	0.625	Single-Family	Lead	Lead	5	Full
32 SIMMONS ST	32	SIMMONS	ST	PROVIDENCE	RI	02909	0.625	Single-Family	Lead	Lead	7	Full
9 SIMMONS ST	9	SIMMONS	ST	PROVIDENCE	RI	02909	0.625	Multi-Family	Lead	Lead	7	Full
4 SIMMONS ST	4	SIMMONS	ST	PROVIDENCE	RI	02909	0.625	Multi-Family	Lead	Lead	7	Full
28 SIMMONS ST	28	SIMMONS	ST	PROVIDENCE	RI	02909	0.625	Multi-Family	Lead	Lead	7	Full
61 SIMMONS ST	61	SIMMONS	ST	PROVIDENCE	RI	02909	0.625	Multi-Family	Lead	Lead	7	Full
84 SIMMONS ST	84	SIMMONS	ST	PROVIDENCE	RI	02909	0.625	Multi-Family	Lead	Lead	7	Full
27 SIMMONS ST	27	SIMMONS	ST	PROVIDENCE	RI	02909	1	Single-Family	Non-Lead	Lead	7	Private Side Only
39 SIMMONS ST	39	SIMMONS	ST	PROVIDENCE	RI	02909	0.625	Multi-Family	Lead	Lead	7	Full
73 SIMMONS ST	73	SIMMONS	ST	PROVIDENCE	RI	02909	0.625	Multi-Family	Lead	Lead	7	Full
90 SIMMONS ST	90	SIMMONS	ST	PROVIDENCE	RI	02909	0.625	Non residential	Lead	Lead	7	Full
66 SIMMONS ST	66	SIMMONS	ST	PROVIDENCE	RI	02909	0.625	Single-Family	Lead	Lead	7	Full
67 SIMMONS ST	67	SIMMONS	ST	PROVIDENCE	RI	02909	0.625	Multi-Family	Lead	Lead	7	Full
20 SIMMONS ST	20	SIMMONS	ST	PROVIDENCE	RI	02909	0.625	Single-Family	Lead	Lead	7	Full
50 SIMMONS ST	50	SIMMONS	ST	PROVIDENCE	RI	02909	0.625	Single-Family	Lead	Lead	7	Full
46 SIMMONS ST	46	SIMMONS	ST	PROVIDENCE	RI	02909	0.625	Single-Family	Lead	Lead	7	Full
58 SIMMONS ST	58	SIMMONS	ST	PROVIDENCE	RI	02909	0.625	Multi-Family	Lead	Lead	7	Full
4 SOPHIA ST	4	SOPHIA	ST	PROVIDENCE	RI	02909	0.625	Multi-Family	Lead	Lead	7	Full
76 SOPHIA ST	76	SOPHIA	ST	PROVIDENCE	RI	02909	0.625	Single-Family	Lead	Lead	7	Full
80 SOPHIA ST	80	SOPHIA	ST	PROVIDENCE	RI	02909	0.625	Single-Family	Lead	Lead	7	Full
39 SOPHIA ST	39	SOPHIA	ST	PROVIDENCE	RI	02909	0.625	Multi-Family	Lead	Lead	7	Full
8 SOPHIA ST	8	SOPHIA	ST	PROVIDENCE	RI	02909	0.625	Multi-Family	Lead	Lead	7	Full
9 SOPHIA ST	9	SOPHIA	ST	PROVIDENCE	RI	02909	1	Multi-Family	Non-Lead	Lead	7	Private Side Only
42 SOPHIA ST	42	SOPHIA	ST	PROVIDENCE	RI	02909	1	Single-Family	Non-Lead	Lead	7	Private Side Only
37 SORRENTO ST	37	SORRENTO	ST	PROVIDENCE	RI	02909	0.625	Multi-Family	Lead	Lead	8	Full
44 SORRENTO ST	44	SORRENTO	ST	PROVIDENCE	RI	02909	0.625	Multi-Family	Lead	Lead	8	Full
43 SORRENTO ST	43	SORRENTO	ST	PROVIDENCE	RI	02909	0.625	Multi-Family	Lead	Lead	8	Full
23 SORRENTO ST	23	SORRENTO	ST	PROVIDENCE	RI	02909	0.625	Multi-Family	Lead	Lead	8	Full
25 SORRENTO ST	25	SORRENTO	ST	PROVIDENCE	RI	02909	0.625	Multi-Family	Lead	Lead	8	Full
49 SORRENTO ST	49	SORRENTO	ST	PROVIDENCE	RI	02909	0.625	Multi-Family	Lead	Lead	8	Full
33 SORRENTO ST	33	SORRENTO	ST	PROVIDENCE	RI	02909	0.625	Multi-Family	Lead	Lead	8	Full
148 SOUTHERN ST	148	SOUTHERN	ST	CRANSTON	RI	02920	0.625	Multi-Family	Lead	Lead	5	Full
100 SOUTHERN ST	100	SOUTHERN	ST	CRANSTON	RI	02920	0.625	Multi-Family	Lead	Lead	5	Full
31 SOUTHERN ST	31	SOUTHERN	ST	CRANSTON	RI	02920	0.625	Multi-Family	Lead	Lead	5	Full
129 SOUTHERN ST	129	SOUTHERN	ST	CRANSTON	RI	02920	0.625	Multi-Family	Lead	Lead	5	Full
52 SOUTHERN ST	52	SOUTHERN	ST	CRANSTON	RI	02920	1	Multi-Family	Non-Lead	Lead	5	Private Side Only
147 SOUTHERN ST	147	SOUTHERN	ST	CRANSTON	RI	02920	0.625	Multi-Family	Lead	Lead	5	Full
59 SOUTHERN ST	59	SOUTHERN	ST	CRANSTON	RI	02920	0.625	Single-Family	Lead	Lead	5	Full
81 SOUTHERN ST	81	SOUTHERN	ST	CRANSTON	RI	02920	0.625	Single-Family	Lead	Non-Lead	5	Public Side Only

FULL ADDRESS	HOUSE NUMBER	STREET	SUFFIX	CITY	STATE	ZIPCODE	SERVICE DIAMETER	BUILDING TYPE	PUBLIC SIDE MATERIAL	PRIVATE SIDE MATERIAL	WARD	REPLACEMENT TYPE
35 SOUTHERN ST	35	SOUTHERN	ST	CRANSTON	RI	02920	0.75	Multi-Family	Lead	Lead	5	Full
9 SOUTHERN ST	9	SOUTHERN	ST	CRANSTON	RI	02920	0.625	Multi-Family	Lead	Lead	5	Full
86 SOUTHERN ST	86	SOUTHERN	ST	CRANSTON	RI	02920	0.625	Single-Family	Lead	Lead	5	Full
88 SOUTHERN ST	88	SOUTHERN	ST	CRANSTON	RI	02920	0.625	Multi-Family	Lead	Lead	5	Full
163 SOUTHERN ST	163	SOUTHERN	ST	CRANSTON	RI	02920	0.625	Multi-Family	Lead	Lead	5	Full
155 STANWOOD ST	155	STANWOOD	ST	PROVIDENCE	RI	02907	1	Multi-Family	Non-Lead	Lead	9	Private Side Only
67 STANWOOD ST	67	STANWOOD	ST	PROVIDENCE	RI	02907	1	Multi-Family	Non-Lead	Lead	9	Private Side Only
71 STANWOOD ST	71	STANWOOD	ST	PROVIDENCE	RI	02907	1	Single-Family	Non-Lead	Lead	9	Private Side Only
59 STANWOOD ST	59	STANWOOD	ST	PROVIDENCE	RI	02907	1	Multi-Family	Non-Lead	Lead	9	Private Side Only
180 STANWOOD ST	180	STANWOOD	ST	PROVIDENCE	RI	02907	1	Multi-Family	Non-Lead	Lead	9	Private Side Only
78 STANWOOD ST	78	STANWOOD	ST	PROVIDENCE	RI	02907	1	Single-Family	Non-Lead	Lead	9	Private Side Only
166 STANWOOD ST	166	STANWOOD	ST	PROVIDENCE	RI	02907	1	Multi-Family	Non-Lead	Lead	9	Private Side Only
188 STANWOOD ST	188	STANWOOD	ST	PROVIDENCE	RI	02907	1	Multi-Family	Non-Lead	Lead	9	Private Side Only
120 STANWOOD ST	120	STANWOOD	ST	PROVIDENCE	RI	02907	1	Multi-Family	Non-Lead	Lead	9	Private Side Only
37 STANWOOD ST	37	STANWOOD	ST	PROVIDENCE	RI	02907	1	Single-Family	Non-Lead	Lead	9	Private Side Only
22 STANWOOD ST	22	STANWOOD	ST	PROVIDENCE	RI	02907	1	Multi-Family	Non-Lead	Lead	9	Private Side Only
124 STANWOOD ST	124	STANWOOD	ST	PROVIDENCE	RI	02907	1	Multi-Family	Non-Lead	Lead	9	Private Side Only
61 STANWOOD ST	61	STANWOOD	ST	PROVIDENCE	RI	02907	1	Multi-Family	Non-Lead	Lead	9	Private Side Only
55 STANWOOD ST	55	STANWOOD	ST	PROVIDENCE	RI	02907	1	Multi-Family	Non-Lead	Lead	9	Private Side Only
125 STANWOOD ST	125	STANWOOD	ST	PROVIDENCE	RI	02907	1	Multi-Family	Non-Lead	Lead	9	Private Side Only
32 STANWOOD ST	32	STANWOOD	ST	PROVIDENCE	RI	02907	1	Multi-Family	Non-Lead	Lead	9	Private Side Only
146 STANWOOD ST	146	STANWOOD	ST	PROVIDENCE	RI	02907	1	Multi-Family	Non-Lead	Lead	9	Private Side Only
33 STANWOOD ST	33	STANWOOD	ST	PROVIDENCE	RI	02907	1	Multi-Family	Non-Lead	Lead	9	Private Side Only
149 STANWOOD ST	149	STANWOOD	ST	PROVIDENCE	RI	02907	1	Multi-Family	Non-Lead	Lead	9	Private Side Only
50 STANWOOD ST	50	STANWOOD	ST	PROVIDENCE	RI	02907	1	Multi-Family	Non-Lead	Lead	9	Private Side Only
74 STANWOOD ST	74	STANWOOD	ST	PROVIDENCE	RI	02907	1	Single-Family	Non-Lead	Lead	9	Private Side Only
161 STANWOOD ST	161	STANWOOD	ST	PROVIDENCE	RI	02907	1	Multi-Family	Non-Lead	Lead	9	Private Side Only
144 STANWOOD ST	144	STANWOOD	ST	PROVIDENCE	RI	02907	1	Single-Family	Non-Lead	Lead	9	Private Side Only
58 STANWOOD ST	58	STANWOOD	ST	PROVIDENCE	RI	02907	1	Multi-Family	Non-Lead	Lead	9	Private Side Only
19 STANWOOD ST	19	STANWOOD	ST	PROVIDENCE	RI	02907	1	Multi-Family	Non-Lead	Lead	9	Private Side Only
121 STANWOOD ST	121	STANWOOD	ST	PROVIDENCE	RI	02907	1	Multi-Family	Non-Lead	Lead	9	Private Side Only
98 STANWOOD ST	98	STANWOOD	ST	PROVIDENCE	RI	02907	1	Single-Family	Non-Lead	Lead	9	Private Side Only
104 STANWOOD ST	104	STANWOOD	ST	PROVIDENCE	RI	02907	1	Single-Family	Non-Lead	Lead	9	Private Side Only
165 STANWOOD ST	165	STANWOOD	ST	PROVIDENCE	RI	02907	1	Single-Family	Non-Lead	Lead	9	Private Side Only
45 STANWOOD ST	45	STANWOOD	ST	PROVIDENCE	RI	02907	1	Multi-Family	Non-Lead	Lead	9	Private Side Only
31 STANWOOD ST	31	STANWOOD	ST	PROVIDENCE	RI	02907	1	Multi-Family	Non-Lead	Lead	9	Private Side Only
16 URBANA ST	16	URBANA	ST	CRANSTON	RI	02920	0.75	Single-Family	Non-Lead	Lead	5	Private Side Only
34 VERMONT ST	34	VERMONT	ST	CRANSTON	RI	02920	0.625	Single-Family	Lead	Non-Lead	5	Public Side Only
23 VERMONT ST	23	VERMONT	ST	CRANSTON	RI	02920	0.625	Multi-Family	Lead	Lead	5	Full
18 VERMONT ST	18	VERMONT	ST	CRANSTON	RI	02920	0.625	Single-Family	Lead	Lead	5	Full
33 VERMONT ST	33	VERMONT	ST	CRANSTON	RI	02920	1	Multi-Family	Non-Lead	Lead	5	Private Side Only

FULL ADDRESS	HOUSE NUMBER	STREET	SUFFIX	CITY	STATE	ZIPCODE	SERVICE DIAMETER	BUILDING TYPE	PUBLIC SIDE MATERIAL	PRIVATE SIDE MATERIAL	WARD	REPLACEMENT TYPE
56 VERMONT ST	56	VERMONT	ST	CRANSTON	RI	02920	1	Single-Family	Non-Lead	Lead	5	Private Side Only
66 VERMONT ST	66	VERMONT	ST	CRANSTON	RI	02920	0.625	Multi-Family	Lead	Lead	5	Full
21 VIGILANT ST	21	VIGILANT	ST	CRANSTON	RI	02920	0.625	Multi-Family	Lead	Lead	5	Full
19 VIGILANT ST	19	VIGILANT	ST	CRANSTON	RI	02920	0.75	Single-Family	Non-Lead	Lead	5	Private Side Only
33 VIGILANT ST	33	VIGILANT	ST	CRANSTON	RI	02920	0.625	Single-Family	Lead	Lead	5	Full
50 VINEYARD ST	50	VINEYARD	ST	PROVIDENCE	RI	02907	1	Multi-Family	Non-Lead	Lead	8	Private Side Only
63 VINEYARD ST	63	VINEYARD	ST	PROVIDENCE	RI	02907	1	Multi-Family	Non-Lead	Lead	8	Private Side Only
39 VINEYARD ST	39	VINEYARD	ST	PROVIDENCE	RI	02907	1	Multi-Family	Non-Lead	Lead	8	Private Side Only
60 VINEYARD ST	60	VINEYARD	ST	PROVIDENCE	RI	02907	1	Multi-Family	Non-Lead	Lead	8	Private Side Only
42 VINEYARD ST	42	VINEYARD	ST	PROVIDENCE	RI	02907	1	Multi-Family	Non-Lead	Lead	8	Private Side Only
57 VINEYARD ST	57	VINEYARD	ST	PROVIDENCE	RI	02907	1	Multi-Family	Non-Lead	Lead	8	Private Side Only
35 VINEYARD ST	35	VINEYARD	ST	PROVIDENCE	RI	02907	1	Multi-Family	Non-Lead	Lead	8	Private Side Only
53 VINEYARD ST	53	VINEYARD	ST	PROVIDENCE	RI	02907	1	Multi-Family	Non-Lead	Lead	8	Private Side Only
47 VINEYARD ST	47	VINEYARD	ST	PROVIDENCE	RI	02907	1	Multi-Family	Non-Lead	Lead	8	Private Side Only
54 VINEYARD ST	54	VINEYARD	ST	PROVIDENCE	RI	02907	1	Multi-Family	Non-Lead	Lead	8	Private Side Only
16 VINEYARD ST	16	VINEYARD	ST	PROVIDENCE	RI	02907	1	Single-Family	Non-Lead	Lead	8	Private Side Only
46 VINEYARD ST	46	VINEYARD	ST	PROVIDENCE	RI	02907	1	Single-Family	Non-Lead	Lead	8	Private Side Only
43 VINEYARD ST	43	VINEYARD	ST	PROVIDENCE	RI	02907	1	Multi-Family	Non-Lead	Lead	8	Private Side Only
136 WALES ST	136	WALES	ST	CRANSTON	RI	02920	0.625	Multi-Family	Lead	Lead	3	Full
115 WAVERLY ST	115	WAVERLY	ST	PROVIDENCE	RI	02907	0.625	Multi-Family	Lead	Lead	8	Full
192 WAVERLY ST	192	WAVERLY	ST	PROVIDENCE	RI	02909	0.625	Multi-Family	Lead	Lead	8	Full
45 WAVERLY ST	45	WAVERLY	ST	PROVIDENCE	RI	02907	0.625	Single-Family	Lead	Lead	8	Full
85 WAVERLY ST	85	WAVERLY	ST	PROVIDENCE	RI	02907	0.625	Multi-Family	Lead	Lead	8	Full
31 WAVERLY ST	31	WAVERLY	ST	PROVIDENCE	RI	02907	0.625	Single-Family	Lead	Lead	8	Full
65 WAVERLY ST	65	WAVERLY	ST	PROVIDENCE	RI	02907	0.625	Multi-Family	Lead	Lead	8	Full
137 WAVERLY ST	137	WAVERLY	ST	PROVIDENCE	RI	02907	0.625	Multi-Family	Lead	Lead	8	Full
111 WAVERLY ST	111	WAVERLY	ST	PROVIDENCE	RI	02907	0.625	Multi-Family	Lead	Lead	8	Full
224 WAVERLY ST	224	WAVERLY	ST	PROVIDENCE	RI	02909	0.625	Multi-Family	Lead	Lead	8	Full
98 WAVERLY ST	98	WAVERLY	ST	PROVIDENCE	RI	02907	0.625	Single-Family	Lead	Lead	8	Full
89 WAVERLY ST	89	WAVERLY	ST	PROVIDENCE	RI	02907	0.625	Multi-Family	Lead	Lead	8	Full
95 WAVERLY ST	95	WAVERLY	ST	PROVIDENCE	RI	02907	1	Multi-Family	Lead	Lead	8	Full
220 WAVERLY ST	220	WAVERLY	ST	PROVIDENCE	RI	02909	0.625	Multi-Family	Lead	Lead	8	Full
54 WAVERLY ST	54	WAVERLY	ST	PROVIDENCE	RI	02907	0.625	Multi-Family	Lead	Lead	8	Full
84 WAVERLY ST	84	WAVERLY	ST	PROVIDENCE	RI	02907	0.625	Multi-Family	Lead	Lead	8	Full
80 WAVERLY ST	80	WAVERLY	ST	PROVIDENCE	RI	02907	0.625	Multi-Family	Lead	Lead	8	Full
69 WAVERLY ST	69	WAVERLY	ST	PROVIDENCE	RI	02907	0.625	Multi-Family	Lead	Lead	8	Full
120 WAVERLY ST	120	WAVERLY	ST	PROVIDENCE	RI	02907	0.625	Multi-Family	Lead	Lead	8	Full
188 WAVERLY ST	188	WAVERLY	ST	PROVIDENCE	RI	02909	0.625	Multi-Family	Lead	Lead	8	Full
129 WAVERLY ST	129	WAVERLY	ST	PROVIDENCE	RI	02907	1	Multi-Family	Non-Lead	Lead	8	Private Side Only
182 WAVERLY ST	182	WAVERLY	ST	PROVIDENCE	RI	02909	1	Multi-Family	Non-Lead	Lead	8	Private Side Only
81 WAVERLY ST	81	WAVERLY	ST	PROVIDENCE	RI	02907	0.625	Multi-Family	Lead	Lead	8	Full

FULL ADDRESS	HOUSE NUMBER	STREET	SUFFIX	CITY	STATE	ZIPCODE	SERVICE DIAMETER	BUILDING TYPE	PUBLIC SIDE MATERIAL	PRIVATE SIDE MATERIAL	WARD	REPLACEMENT TYPE
15 WAVERLY ST	15	WAVERLY	ST	PROVIDENCE	RI	02907	0.625	Multi-Family	Lead	Lead	8	Full
170 WAVERLY ST	170	WAVERLY	ST	PROVIDENCE	RI	02909	0.625	Multi-Family	Lead	Lead	8	Full
21 WAVERLY ST	21	WAVERLY	ST	PROVIDENCE	RI	02907	0.75	Multi-Family	Lead	Lead	8	Full
74 WAVERLY ST	74	WAVERLY	ST	PROVIDENCE	RI	02907	0.625	Multi-Family	Lead	Lead	8	Full
78 WAVERLY ST	78	WAVERLY	ST	PROVIDENCE	RI	02907	0.625	Multi-Family	Lead	Lead	8	Full
99 WAVERLY ST	99	WAVERLY	ST	PROVIDENCE	RI	02907	0.625	Multi-Family	Lead	Lead	8	Full
24 WAVERLY ST	24	WAVERLY	ST	PROVIDENCE	RI	02907	0.625	Multi-Family	Lead	Lead	8	Full
46 WAVERLY ST	46	WAVERLY	ST	PROVIDENCE	RI	02907	1	Multi-Family	Non-Lead	Lead	8	Private Side Only
100 WAVERLY ST	100	WAVERLY	ST	PROVIDENCE	RI	02907	0.625	Multi-Family	Lead	Lead	8	Full
20 WAVERLY ST	20	WAVERLY	ST	PROVIDENCE	RI	02907	0.625	Multi-Family	Lead	Lead	8	Full
48 WAVERLY ST	48	WAVERLY	ST	PROVIDENCE	RI	02907	0.625	Multi-Family	Lead	Lead	8	Full
103 WAVERLY ST	103	WAVERLY	ST	PROVIDENCE	RI	02907	0.625	Multi-Family	Lead	Lead	8	Full
68 WAVERLY ST	68	WAVERLY	ST	PROVIDENCE	RI	02907	0.625	Multi-Family	Lead	Lead	8	Full
58 WAVERLY ST	58	WAVERLY	ST	PROVIDENCE	RI	02907	0.75	Multi-Family	Lead	Lead	8	Full
90 WAVERLY ST	90	WAVERLY	ST	PROVIDENCE	RI	02907	0.625	Multi-Family	Lead	Lead	8	Full
104 WAVERLY ST	104	WAVERLY	ST	PROVIDENCE	RI	02907	1	Multi-Family	Non-Lead	Lead	8	Private Side Only
11 WAVERLY ST	11	WAVERLY	ST	PROVIDENCE	RI	02907	0.625	Multi-Family	Lead	Lead	8	Full
138 WAVERLY ST	138	WAVERLY	ST	PROVIDENCE	RI	02907	0.625	Multi-Family	Lead	Lead	8	Full
119 WAVERLY ST	119	WAVERLY	ST	PROVIDENCE	RI	02907	0.625	Multi-Family	Lead	Lead	8	Full
37 WAVERLY ST	37	WAVERLY	ST	PROVIDENCE	RI	02907	0.625	Multi-Family	Lead	Lead	8	Full
198 WAVERLY ST	198	WAVERLY	ST	PROVIDENCE	RI	02909	0.625	Multi-Family	Lead	Non-Lead	8	Public Side Only
109 WAVERLY ST	109	WAVERLY	ST	PROVIDENCE	RI	02907	0.75	Single-Family	Non-Lead	Lead	8	Private Side Only
124 WAVERLY ST	124	WAVERLY	ST	PROVIDENCE	RI	02907	1	Single-Family	Non-Lead	Lead	8	Private Side Only
73 WAVERLY ST	73	WAVERLY	ST	PROVIDENCE	RI	02907	0.625	Multi-Family	Lead	Lead	8	Full
123 WAVERLY ST	123	WAVERLY	ST	PROVIDENCE	RI	02907	1	Multi-Family	Non-Lead	Lead	8	Private Side Only
40 WAVERLY ST	40	WAVERLY	ST	PROVIDENCE	RI	02907	0.625	Single-Family	Lead	Lead	8	Full
42 WAVERLY ST	42	WAVERLY	ST	PROVIDENCE	RI	02907	0.625	Single-Family	Lead	Lead	8	Full
162 WENDELL ST	162	WENDELL	ST	PROVIDENCE	RI	02909	0.625	Multi-Family	Lead	Lead	15	Full
148 WENDELL ST	148	WENDELL	ST	PROVIDENCE	RI	02909	0.625	Multi-Family	Lead	Lead	15	Full
132 WENDELL ST	132	WENDELL	ST	PROVIDENCE	RI	02909	0.625	Multi-Family	Lead	Non-Lead	15	Public Side Only
170 WENDELL ST	170	WENDELL	ST	PROVIDENCE	RI	02909	0.625	Multi-Family	Lead	Lead	15	Full
114 WENDELL ST	114	WENDELL	ST	PROVIDENCE	RI	02909	0.75	Multi-Family	Lead	Lead	15	Full
163 WENDELL ST	163	WENDELL	ST	PROVIDENCE	RI	02909	0.625	Multi-Family	Lead	Lead	15	Full
145 WENDELL ST	145	WENDELL	ST	PROVIDENCE	RI	02909	0.625	Multi-Family	Lead	Lead	15	Full
138 WENDELL ST	138	WENDELL	ST	PROVIDENCE	RI	02909	0.625	Multi-Family	Lead	Lead	15	Full
120 WENDELL ST	120	WENDELL	ST	PROVIDENCE	RI	02909	0.625	Single-Family	Lead	Lead	15	Full
156 WENDELL ST	156	WENDELL	ST	PROVIDENCE	RI	02909	0.625	Multi-Family	Lead	Lead	15	Full
122 WENDELL ST	122	WENDELL	ST	PROVIDENCE	RI	02909	0.75	Multi-Family	Lead	Lead	15	Full
169 WENDELL ST	169	WENDELL	ST	PROVIDENCE	RI	02909	0.625	Multi-Family	Lead	Lead	15	Full
131 WENDELL ST	131	WENDELL	ST	PROVIDENCE	RI	02909	0.625	Single-Family	Lead	Lead	15	Full
128 WENDELL ST	128	WENDELL	ST	PROVIDENCE	RI	02909	0.625	Multi-Family	Lead	Lead	15	Full

FULL ADDRESS	HOUSE NUMBER	STREET	SUFFIX	CITY	STATE	ZIPCODE	SERVICE DIAMETER	BUILDING TYPE	PUBLIC SIDE MATERIAL	PRIVATE SIDE MATERIAL	WARD	REPLACEMENT TYPE
127 WENDELL ST	127	WENDELL	ST	PROVIDENCE	RI	02909	0.625	Multi-Family	Lead	Lead	15	Full
157 WENDELL ST	157	WENDELL	ST	PROVIDENCE	RI	02909	0.625	Multi-Family	Lead	Lead	15	Full
135 WENDELL ST	135	WENDELL	ST	PROVIDENCE	RI	02909	1	Multi-Family	Lead	Lead	15	Full
153 WENDELL ST	153	WENDELL	ST	PROVIDENCE	RI	02909	0.625	Multi-Family	Lead	Lead	15	Full
149 WENDELL ST	149	WENDELL	ST	PROVIDENCE	RI	02909	0.625	Multi-Family	Lead	Lead	15	Full
136 WENDELL ST	136	WENDELL	ST	PROVIDENCE	RI	02909	0.625	Multi-Family	Lead	Lead	15	Full
142 WENDELL ST	142	WENDELL	ST	PROVIDENCE	RI	02909	0.625	Multi-Family	Lead	Lead	15	Full
141 WENDELL ST	141	WENDELL	ST	PROVIDENCE	RI	02909	0.625	Multi-Family	Lead	Lead	15	Full
119 WENDELL ST	119	WENDELL	ST	PROVIDENCE	RI	02909	0.625	Multi-Family	Lead	Lead	15	Full
173 WENDELL ST	173	WENDELL	ST	PROVIDENCE	RI	02909	0.625	Multi-Family	Lead	Non-Lead	15	Public Side Only
149 WHITMARSH ST	149	WHITMARSH	ST	PROVIDENCE	RI	02907	1	Multi-Family	Non-Lead	Lead	8	Private Side Only
153 WHITMARSH ST	153	WHITMARSH	ST	PROVIDENCE	RI	02907	1	Multi-Family	Non-Lead	Lead	8	Private Side Only
190 WHITMARSH ST	190	WHITMARSH	ST	PROVIDENCE	RI	02907	1	Multi-Family	Non-Lead	Lead	8	Private Side Only
181 WHITMARSH ST	181	WHITMARSH	ST	PROVIDENCE	RI	02907	1	Multi-Family	Non-Lead	Lead	8	Private Side Only
152 WHITMARSH ST	152	WHITMARSH	ST	PROVIDENCE	RI	02907	1	Multi-Family	Non-Lead	Lead	8	Private Side Only
166 WHITMARSH ST	166	WHITMARSH	ST	PROVIDENCE	RI	02907	1	Multi-Family	Non-Lead	Lead	8	Private Side Only
191 WHITMARSH ST	191	WHITMARSH	ST	PROVIDENCE	RI	02907	1	Multi-Family	Non-Lead	Lead	8	Private Side Only
145 WHITMARSH ST	145	WHITMARSH	ST	PROVIDENCE	RI	02907	1	Non residential	Non-Lead	Lead	8	Private Side Only
167 WHITMARSH ST	167	WHITMARSH	ST	PROVIDENCE	RI	02907	1	Multi-Family	Non-Lead	Lead	8	Private Side Only
170 WHITMARSH ST	170	WHITMARSH	ST	PROVIDENCE	RI	02907	1	Multi-Family	Non-Lead	Lead	8	Private Side Only
182 WHITMARSH ST	182	WHITMARSH	ST	PROVIDENCE	RI	02907	1	Multi-Family	Non-Lead	Lead	8	Private Side Only
186 WHITMARSH ST	186	WHITMARSH	ST	PROVIDENCE	RI	02907	1	Multi-Family	Non-Lead	Lead	8	Private Side Only
142 WHITMARSH ST	142	WHITMARSH	ST	PROVIDENCE	RI	02907	1	Multi-Family	Non-Lead	Lead	8	Private Side Only
159 WHITMARSH ST	159	WHITMARSH	ST	PROVIDENCE	RI	02907	1	Single-Family	Non-Lead	Lead	8	Private Side Only
171 WHITMARSH ST	171	WHITMARSH	ST	PROVIDENCE	RI	02907	1	Multi-Family	Non-Lead	Lead	8	Private Side Only
185 WHITMARSH ST	185	WHITMARSH	ST	PROVIDENCE	RI	02907	1	Multi-Family	Non-Lead	Lead	8	Private Side Only
174 WHITMARSH ST	174	WHITMARSH	ST	PROVIDENCE	RI	02907	1	Single-Family	Non-Lead	Lead	8	Private Side Only
175 WHITMARSH ST	175	WHITMARSH	ST	PROVIDENCE	RI	02907	1	Single-Family	Non-Lead	Lead	8	Private Side Only
163 WHITMARSH ST	163	WHITMARSH	ST	PROVIDENCE	RI	02907	1	Single-Family	Non-Lead	Lead	8	Private Side Only
146 WHITMARSH ST	146	WHITMARSH	ST	PROVIDENCE	RI	02907	1	Multi-Family	Non-Lead	Lead	8	Private Side Only

Appendix B

Construction Details

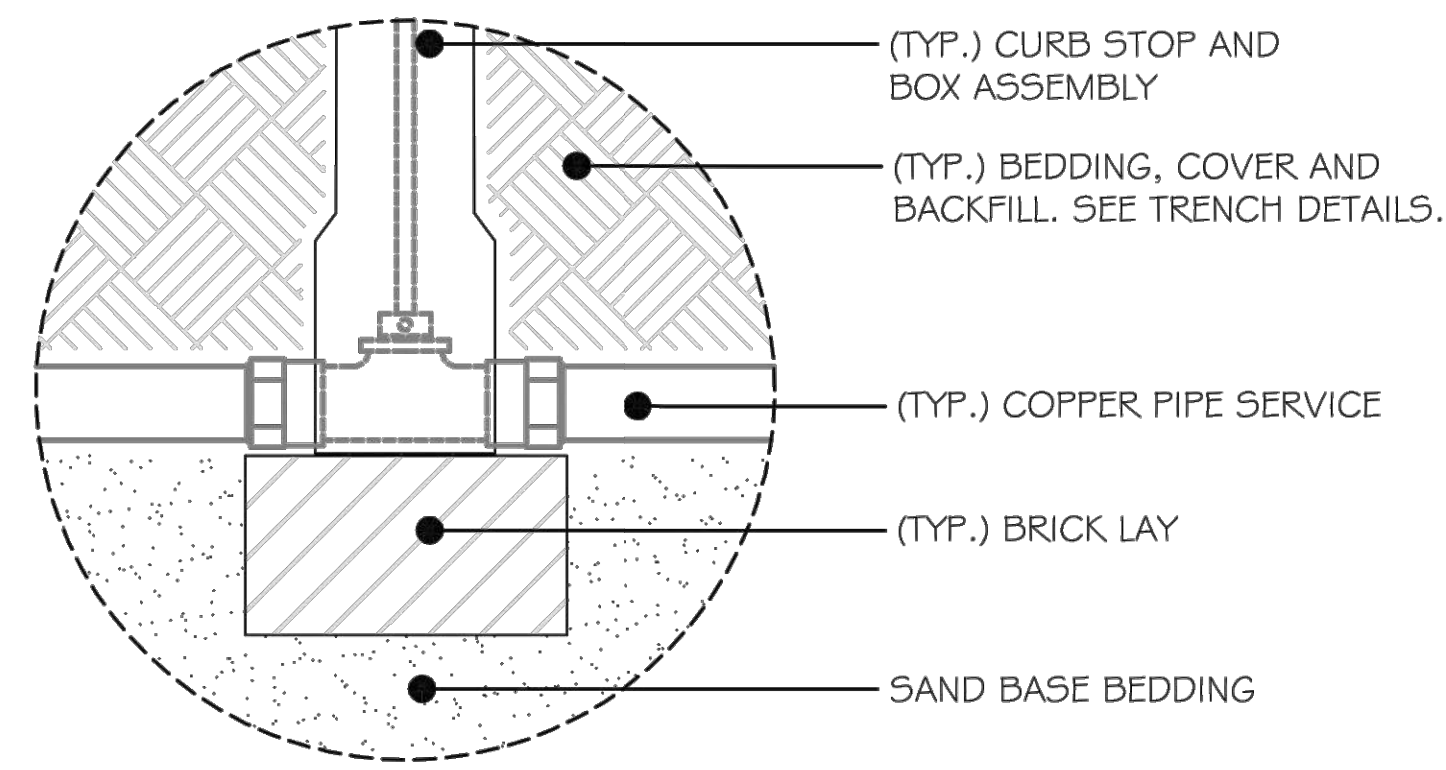

CURB STOP BASE ENLARGEMENT
NTS

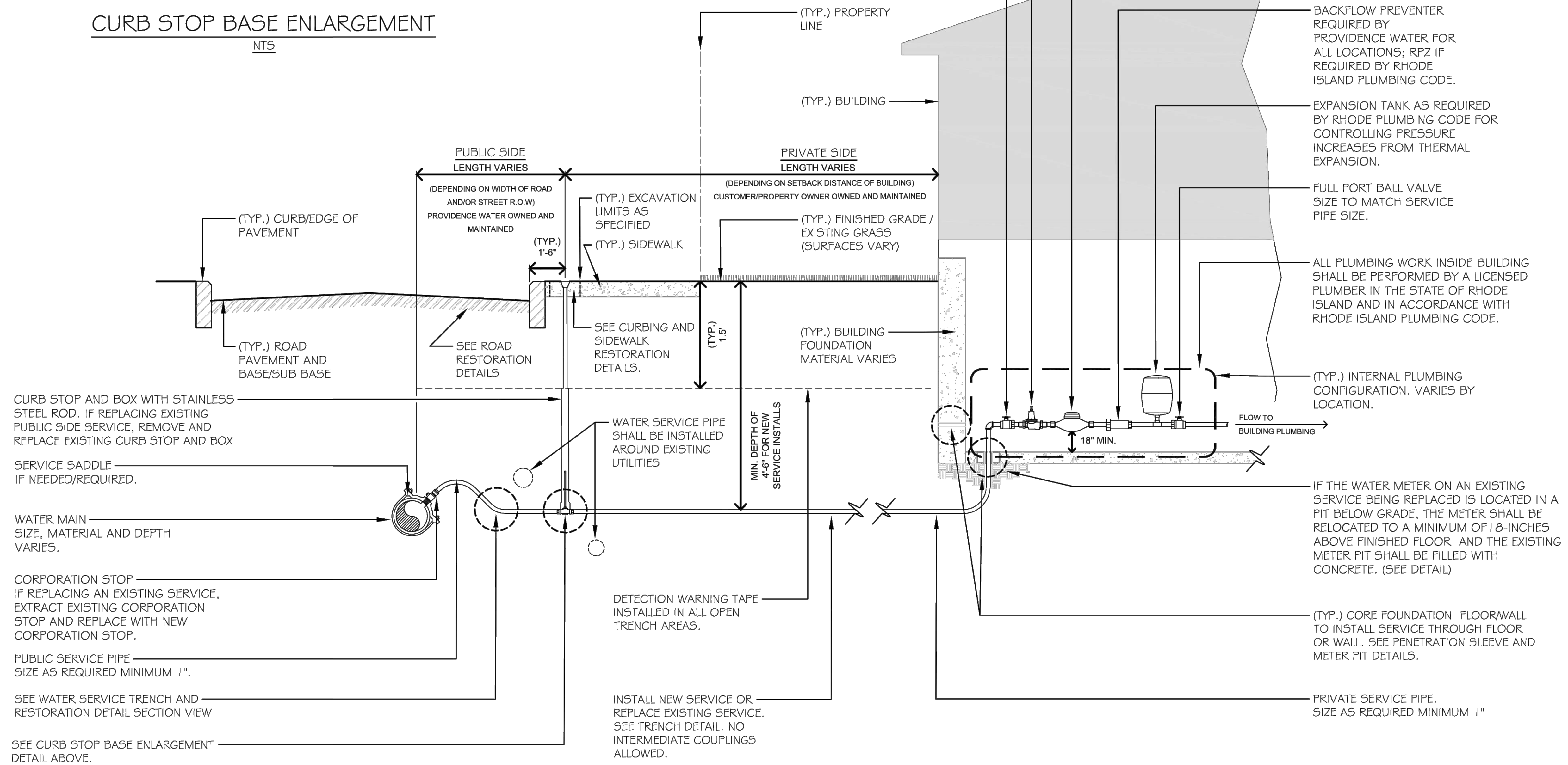

TYPICAL RESIDENTIAL WATER SERVICE CONNECTION - ELEVATION / SECTION VIEW
NOT TO SCALE

GENERAL NOTES:

1. THIS DETAIL REPRESENTS TYPICAL CONDITIONS AND WATER SERVICE CONNECTION DETAILS AND REQUIREMENTS. EACH LOCATION WILL VARY BASED ON SITE-SPECIFIC CONDITIONS.
2. PUBLIC SIDE SERVICE OWNED AND MAINTAINED BY PROVIDENCE WATER IS FROM THE WATER MAIN UP TO AND INCLUDING THE CURB STOP AND BOX. PRIVATE SIDE SERVICES IS OWNED AND MAINTAINED BY THE PROPERTY OWNER AND IS FROM THE CURB STOP INTO THE BUILDING. ALL EXISTING WATER METERS INSIDE BUILDINGS ARE OWNED BY PROVIDENCE WATER. ALL OTHER INTERNAL PLUMBING INSIDE BUILDINGS IS OWNED BY PROPERTY OWNER.
3. THE MAXIMUM ALLOWABLE LENGTH OF A SERVICE CONNECTION TO A BUILDING FROM THE CURB STOP IS 100 FEET (NO COUPLINGS ALLOWED). ABOVE GROUND HEATED ENCLOSURES ARE REQUIRED FOR DISTANCES EXCEEDING 100 FEET.
4. WATER SERVICE CONNECTIONS MAY BE INSTALLED OR REPLACED BY OPEN CUT OR TRENCHLESS CONSTRUCTION METHODS AS SPECIFIED. TRENCHLESS METHODS SHALL BE UTILIZED WHEREVER POSSIBLE, ESPECIALLY WHEN REPLACING EXISTING SERVICE CONNECTIONS.
5. CONTRACTOR SHALL PROVIDE ALL MATERIALS, EQUIPMENT, TOOLS, LABOR, SERVICES, APPURTENANCES, AND INCIDENTALS TO COMPLETE ALL REQUIRED WORK AS SHOWN AND AS SPECIFIED.
6. CONTRACTOR IS RESPONSIBLE FOR ALL REQUIRED BONDS, INSURANCE, AND PERMITS TO COMPLETE ALL WORK.
7. ALL NEW MATERIALS SHALL MEET LEAD FREE STANDARDS AS SPECIFIED. ALL MATERIALS SHALL BE AS SPECIFIED BY PROVIDENCE WATER AND IN ACCORDANCE WITH PROVIDENCE WATER APPROVED MATERIALS AND MANUFACTURERS.
8. BEFORE ANY WORK COMMENCES ON PRIVATE PROPERTY RELATED TO PRIVATE SIDE WATER SERVICE CONNECTIONS, A PROPERLY SIGNED AND EXECUTED AGREEMENT (RIGHT-OF-ENTRY (ROE)) FORM MUST BE OBTAINED FROM THE PROPERTY OWNER AND BE IN THE POSSESSION OF AND APPROVED BY PROVIDENCE WATER.
9. CONTRACTOR SHALL COORDINATE ALL WATER SERVICE CONNECTION WORK AND ACTIVITIES WITH PROVIDENCE WATER, PROVIDENCE WATER'S REPRESENTATIVES (INSPECTORS, ENGINEERS, ETC.), PROPERTY OWNER(S), AND RESIDENT(S)/TENANT(S).
10. CONTRACTOR IS RESPONSIBLE FOR ALL NEEDED AND REQUIRED ENVIRONMENTAL PROTECTION MEASURES; SEDIMENTATION AND EROSION CONTROL MEASURES; TRAFFIC/PEDESTRIAN CONTROL AND MANAGEMENT DEVICES, EQUIPMENT AND MEASURES; AND FOR PROVIDING ALL UNIFORMED TRAFFIC CONTROL (POLICE DETAILS AND/OR FLAGGERS).
11. CORPORATION STOP SHALL BE DIRECT TAPPED ON CAST-IRON (CI) AND DUCTILE-IRON (DI) WATER MAINS. SERVICE SADDLES SHALL BE USED ON ASBESTOS CEMENT (AC) WATER MAINS.
12. FOR NEW INSTALLATIONS, WATER SERVICE CONNECTIONS SHALL NOT BE INSTALLED IN THE SAME TRENCH AS AND SHALL BE AT LEAST 25 FEET AWAY FROM ANY SEWAGE DISPOSAL SYSTEM, SEPTIC TANK, OR CESSPOOL. WATER SERVICE CONNECTIONS CLOSER THAN THESE ALLOWABLE DISTANCES SHALL BE ENCASED IN A WATERTIGHT CARRIER PIPE (SCHEDULE 40 PVC PIPE). JOINTS OF THE PVC CARRIER PIPE SHALL BE JOINED TOGETHER AND SEALED TO FORM WATERTIGHT CONNECTIONS. END SECTIONS OF THE PVC CARRIER PIPE SHALL BE FITTED WITH MECHANICAL DEVICES TO WATERTIGHT SEAL THE ENDS AND THE SPACES BETWEEN THE WATER SERVICE PIPE AND THE PVC CARRIER PIPE. WATER SERVICE CONNECTIONS SHALL BE LOCATED ABOVE ANY DRAIN OR SEWER WITH AT LEAST 12" VERTICAL SEPARATION. IF WATER SERVICE CROSSES ANY DRAIN OR SEWER LINE, DRAIN / SEWER SHALL BE CONCRETE ENCASED IN 6" OF CONCRETE FOR 10' ON EACH SIDE OF WATER SERVICE.
13. ALL PLUMBING WORK INSIDE BUILDINGS SHALL BE PERFORMED BY A LICENSED PLUMBER IN THE STATE OF RHODE ISLAND AND IN ACCORDANCE WITH RHODE ISLAND PLUMBING CODE.
14. EXISTING MATERIALS REMOVED DURING CONSTRUCTION (THAT ARE NOT FOR REUSE) SHALL BE REMOVED AND DISPOSED OF BY THE CONTRACTOR AS REQUIRED AND SPECIFIED AND IN ACCORDANCE WITH ALL FEDERAL, STATE, AND LOCAL LAWS, REGULATIONS, AND/OR REQUIREMENTS.
15. CONTRACTOR SHALL RESTORE SURFACE FEATURES (ROADS, SIDEWALKS, AND GRASS AREAS) DISTURBED DURING CONSTRUCTION TO A CONDITION EQUAL TO OR BETTER THAN PRE-CONSTRUCTION CONDITIONS AS SPECIFIED AND IN ACCORDANCE WITH ALL MUNICIPAL PERMIT CONDITIONS.
16. FOR CONCRETE SIDEWALK RESTORATION, THE CONTRACTOR SHALL REPLACE ENTIRE CONCRETE SIDEWALK PANEL(S) WITHIN LIMITS OF DISTURBANCE. LIMITS OF SIDEWALK REPLACEMENT SHALL BE AT EXISTING CONTROL JOINTS. PARTIAL SIDEWALK REPLACEMENT/PATCHING IS NOT ACCEPTABLE OR PERMITTED. SAVING AND REINSTALLING EXISTING SIDEWALK PANELS IS ALSO NOT ACCEPTABLE OR PERMITTED. CONCRETE SIDEWALK RESTORATION SHALL BE AS SPECIFIED AND IN ACCORDANCE WITH ALL MUNICIPAL PERMIT CONDITIONS. PROVIDENCE WATER MAY DIRECT CONTRACTOR TO ALSO REPLACE ADDITIONAL ADJACENT SIDEWALK PANELS.
17. CONTRACTOR SHALL REPAIR AND WATERTIGHT SEAL ALL FOUNDATION FLOOR AND/OR WALL PENETRATIONS.
18. ANY ITEMS (INCLUDING BUT NOT LIMITED TO WALLS, FENCES, SHRUBS, PLANTS, LIVING PLANT MATERIAL, LANDSCAPING, STONES, PAVERS, BRICK SIDEWALKS OR DRIVEWAYS, ETC.) ON PRIVATE PROPERTY THAT ARE DISTURBED BY CONTRACTOR DURING CONSTRUCTION SHALL BE LEFT IN GOOD/EXISTING CONDITION BY CONTRACTOR FOR REUSE BY THE PROPERTY OWNER(S)/RESIDENT(S). CONTRACTOR SHALL USE CARE AND CAUTION TO PROTECT, PRESERVE, AND NOT DAMAGE ANY ITEMS ON PRIVATE PROPERTY.
19. CONTRACTOR IS RESPONSIBLE FOR REPAIRING ANY DAMAGE CAUSED BY THE CONTRACTOR TO ANY ADJACENT UTILITIES AND ANY ITEMS ON PRIVATE PROPERTY.

TYPICAL RESIDENTIAL WATER SERVICE CONNECTION - GENERAL NOTES SECTION

NOT TO SCALE

UNPAVED AREAS

PAVED AREAS

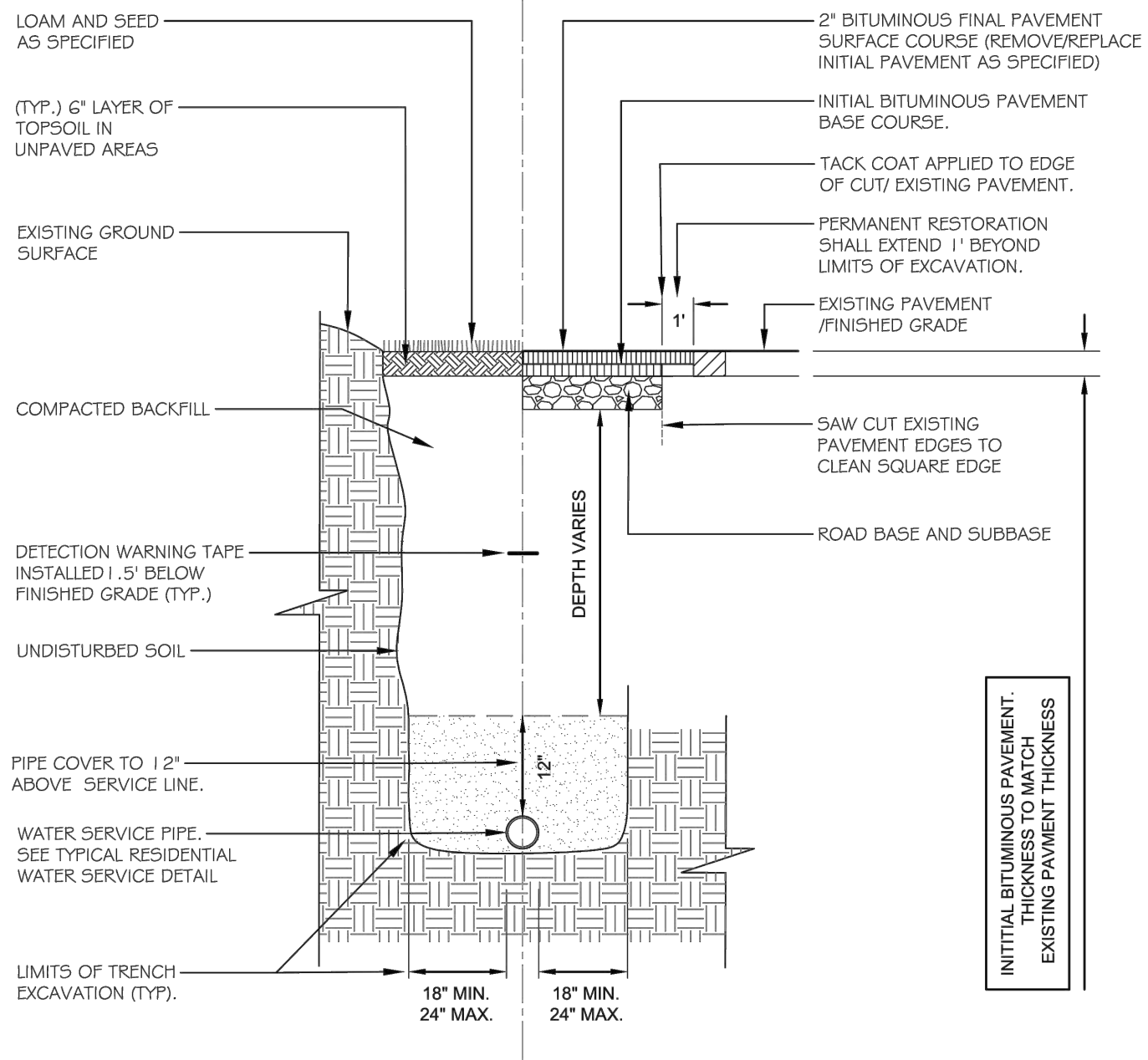

GENERAL NOTES:

1. THIS DETAIL REPRESENTS TYPICAL CONDITIONS AND RESTORATION REQUIREMENTS.
2. CONTRACTOR SHALL PROVIDE ALL MATERIALS, EQUIPMENT, TOOLS, LABOR, SERVICES, APPURTENANCES, AND INCIDENTALS TO COMPLETE ALL REQUIRED WORK AS SHOWN AND AS SPECIFIED.
3. CONTRACTOR IS RESPONSIBLE FOR ALL REQUIRED BONDS, INSURANCE, AND PERMITS TO COMPLETE ALL WORK.
4. ALL PAVING AND RESTORATION WORK SHALL BE AS SPECIFIED AND IN ACCORDANCE WITH ALL MUNICIPAL PERMIT CONDITIONS.
5. CONTRACTOR IS RESPONSIBLE FOR ALL NEEDED AND REQUIRED ENVIRONMENTAL PROTECTION MEASURES; SEDIMENTATION AND EROSION CONTROL MEASURES; TRAFFIC/PEDESTRIAN CONTROL AND MANAGEMENT DEVICES, EQUIPMENT AND MEASURES; AND FOR PROVIDING ALL UNIFORMED TRAFFIC CONTROL (POLICE DETAILS AND/OR FLAGGERS).
6. ALL TRAFFIC CONTROL SHALL BE IN ACCORDANCE WITH THE MANUAL ON UNIFORM TRAFFIC CONTROL DEVICES (MUTCD) FOR STREETS AND HIGHWAYS.
7. BEDDING AND BACKFILL MATERIALS SHALL BE AS SPECIFIED AND PLACED IN MAXIMUM 12" LIFTS COMPACTED AS SPECIFIED TO MINIMUM 95% COMPACTION.
8. INITIAL BITUMINOUS PAVEMENT SHALL MATCH EXISTING PAVEMENT THICKNESS AND BE MINIMUM 4" THICK AND MATCH EXISTING GRADE.
9. TEMPORARY TRAFFIC STRIPES AND PAVEMENT MARKINGS SHALL BE PLACED IMMEDIATELY UPON THE PLACEMENT OF TEMPORARY OR INITIAL PAVEMENT. ALL PERMANENT TRAFFIC STRIPES AND PAVEMENT MARKINGS TO BE PLACED AFTER FINAL PAVING TO REPLACE ANY DISTURBED DURING CONSTRUCTION.
10. MAXIMUM PAY WIDTH FOR PIPE TRENCH IS 24" ON EITHER SIDE OF PIPE. MAXIMUM PAY WIDTH FOR WATER SERVICE TRENCH IS 4' TOTAL WIDTH.
11. FINAL PAVEMENT FOR ROADS UNDER MORATORIUM (WHERE WORK IS APPROVED TO BE PERFORMED BY THE LOCAL MUNICIPALITY) SHALL BE INFRA-RED REPAIRED TO CREATE SEAMLESS OVERLAY OF NEW PAVEMENT WITH EXISTING PAVEMENT.
12. CONTRACTOR IS RESPONSIBLE FOR REPAIRING ANY DAMAGE CAUSED BY THE CONTRACTOR TO ANY ADJACENT UTILITIES AND DAMAGE CAUSED TO PUBLIC OR PRIVATE PROPERTY.
13. CONTRACTOR IS RESPONSIBLE FOR SCHEDULING AND COORDINATING ALL REQUIRED FINAL PAVEMENT INSPECTIONS WITH THE RESPECTIVE JURISDICTION (LOCAL MUNICIPALITY, RIDOT, ETC.).

INITIAL BITUMINOUS PAVEMENT THICKNESS TO MATCH EXISTING PAVEMENT THICKNESS

SECTION VIEW

TYPICAL DETAIL WATER MAIN & WATER SERVICE TRENCH DETAIL

NOT TO SCALE

<u>PIPE COVER</u>	=	SELECT COMMON FILL
<u>COMPACTED BACKFILL</u>	=	COMMON FILL

SOURCE: PROVIDENCE WATER SUPPLY BOARD



CITY OF PROVIDENCE, RHODE ISLAND
 PROVIDENCE WATER SUPPLY BOARD
 ACCELERATED LEAD SERVICE LINE REPLACEMENT PROGRAM
 CONTRACT 1.4

Detail No. 2

MARCH 2024

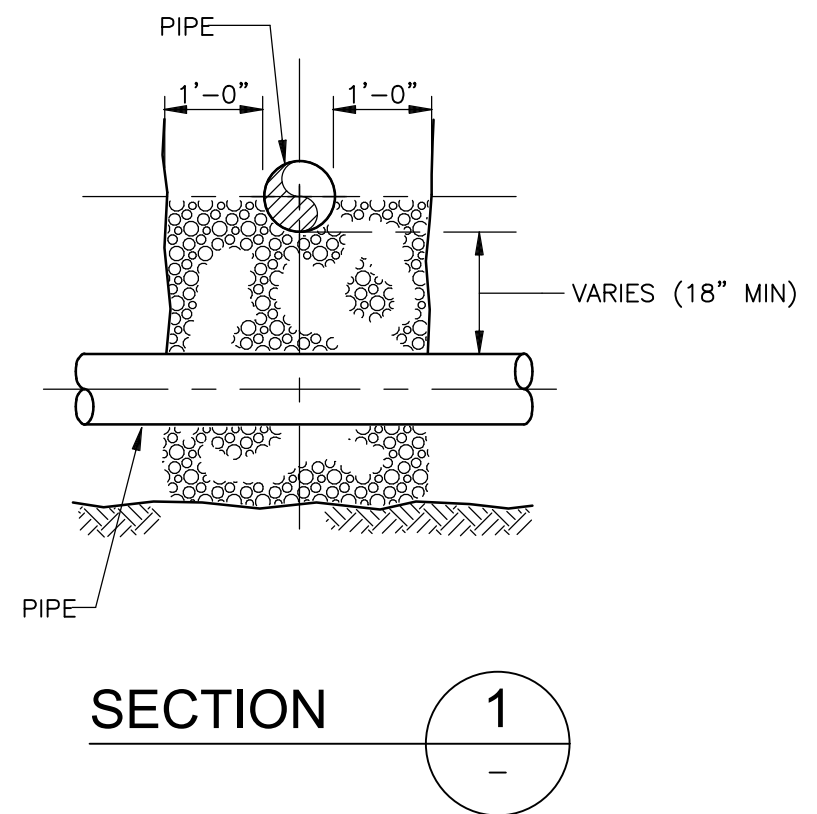
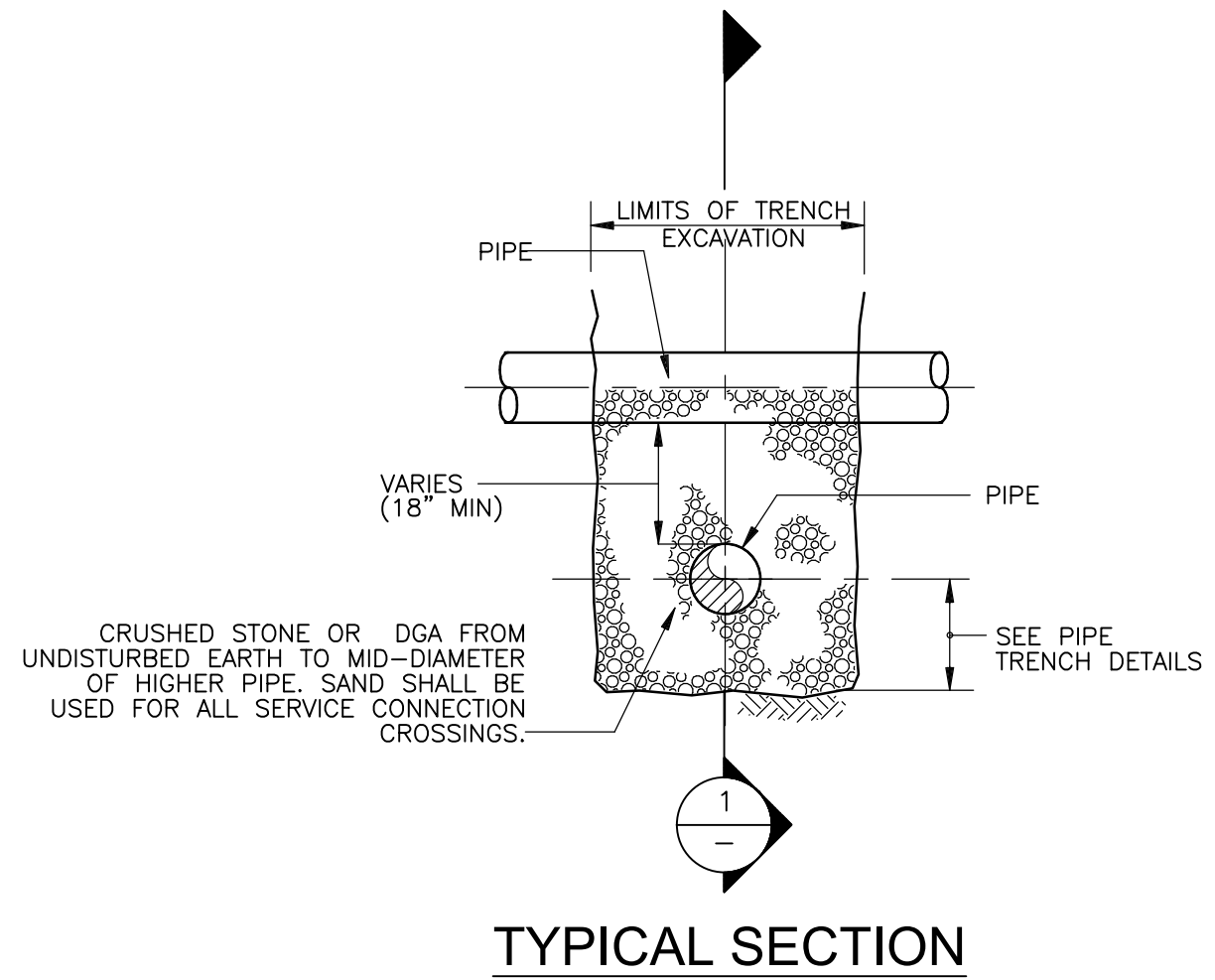

CRUSHED STONE OR DGA FROM UNDISTURBED EARTH TO MID-DIAMETER OF HIGHER PIPE. SAND SHALL BE USED FOR ALL SERVICE CONNECTION CROSSINGS.

NOTES:

1. CONTRACTOR SHALL PROTECT EXISTING UTILITIES, AND SHALL BRACE AND SUPPORT THE UTILITIES PROPERLY TO PREVENT SETTLEMENT, DISPLACEMENT, OR DAMAGE TO THE UTILITIES. CONTRACTOR SHALL ALSO MEET SPECIAL REQUIREMENTS FOR UTILITIES IDENTIFIED HEREIN. THE CONTRACTOR SHALL LIMIT THE EXTERNAL LOADING ON EXISTING UTILITIES CAUSED BY CONSTRUCTION ACTIVITIES. THE CONTRACTOR SHALL USE CRANE PADS OR TIMBER PADS TO DISTRIBUTE EQUIPMENT LOADS. THE CONTRACTOR SHALL VERIFY ACCEPTABLE LOADING FOR EXISTING UTILITIES PRIOR TO STAGING EXTERNAL LOADS ON THE SITE.
2. WHENEVER A SANITARY/COMBINED SEWER CROSSES UNDER OR OVER A WATER MAIN, THE MINIMUM VERTICAL DISTANCE BETWEEN THE TOP OF THE BOTTOM PIPE AND BOTTOM OF THE TOP PIPE SHALL BE 18 INCHES. FURTHERMORE, A MINIMUM HORIZONTAL DISTANCE OF 10 FEET BETWEEN SANITARY/COMBINED SEWERS AND WATER MAINS SHALL BE MAINTAINED UNLESS: THE SEWER IS LAID IN A SEPARATE TRENCH, KEEPING A MINIMUM 18 INCHES VERTICAL SEPARATION; OR THE SEWER IS LAID IN THE SAME TRENCH WITH THE WATER MAIN LOCATED AT THE OPPOSITE SIDE ON A BENCH OF UNDISTURBED EARTH, KEEPING A MINIMUM 18 INCHES VERTICAL SEPARATION. WATER MAIN JOINTS SHALL BE LOCATED AS FAR FROM THE SANITARY SEWER CROSSING AS POSSIBLE (MINIMUM 9 FEET) AND JOINTS ON EITHER END OF WATER MAINS AT SANITARY SEWER CROSSINGS SHALL BE RESTRAINED.

UTILITY CROSSING DETAIL
NTS

XREFs: [Images: []
 Last saved by: CABRERAJG Time: 6/29/2023 9:18:00 AM
 C:\pw_pl1\cabrerajg\3271389\DETAIL 3.dwg



XREFs: [] Images: []
 Last saved by: CABRERAJG Time: 6/29/2023 10:20:05 AM
 C:\pw_pl1\cabrerajg\3271389\DETAIL 4.dwg

NOTE:
 INSULATED PIPING:
 INTERRUPT INSULATION AT
 BOTH SIDES OF WALL. INSTALL
 INSULATION FLUSH WITH WALL
 AFTER WATER TIGHT
 INSTALLATION OF MECHANICAL
 SEAL.

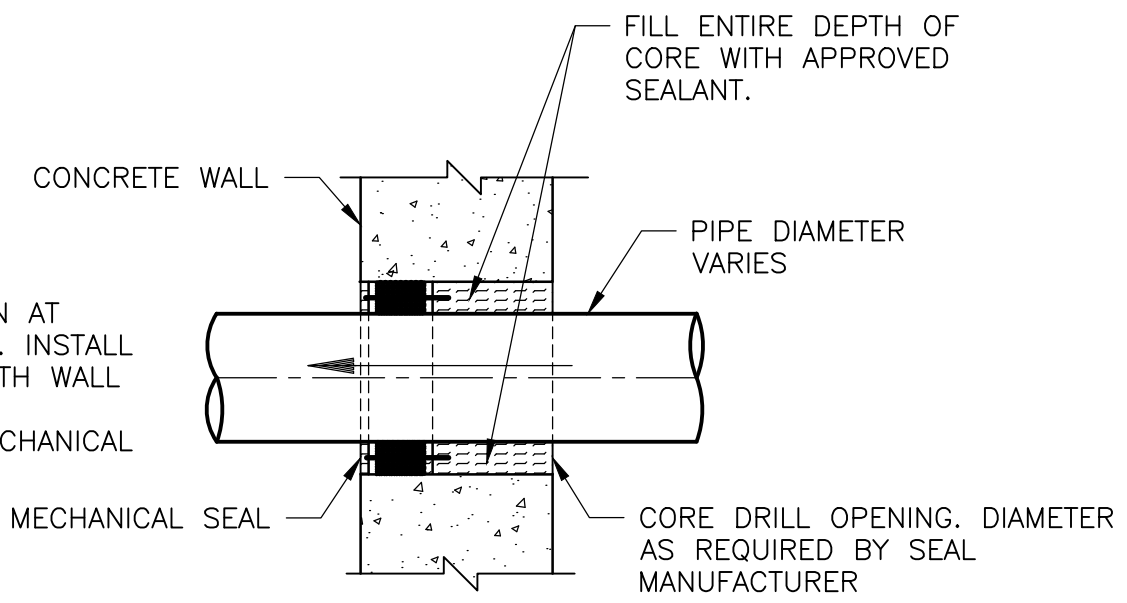

- NOTES:**
1. WHERE PIPE PASSES THROUGH FIRE RATED AREAS, INSTALL SEALS ON BOTH SIDES OF WALL. MECHANICAL SEALS SHALL BE FIRE RATED ASSEMBLIES.
 2. IN LIEU OF MECHANICAL SEALS, NON-SHRINK GROUT, AS SPECIFIED, FILLING ALL VOIDS MAY BE USED FOR CONCRETE WALLS.

WALL PENETRATION
DETAIL
 NTS

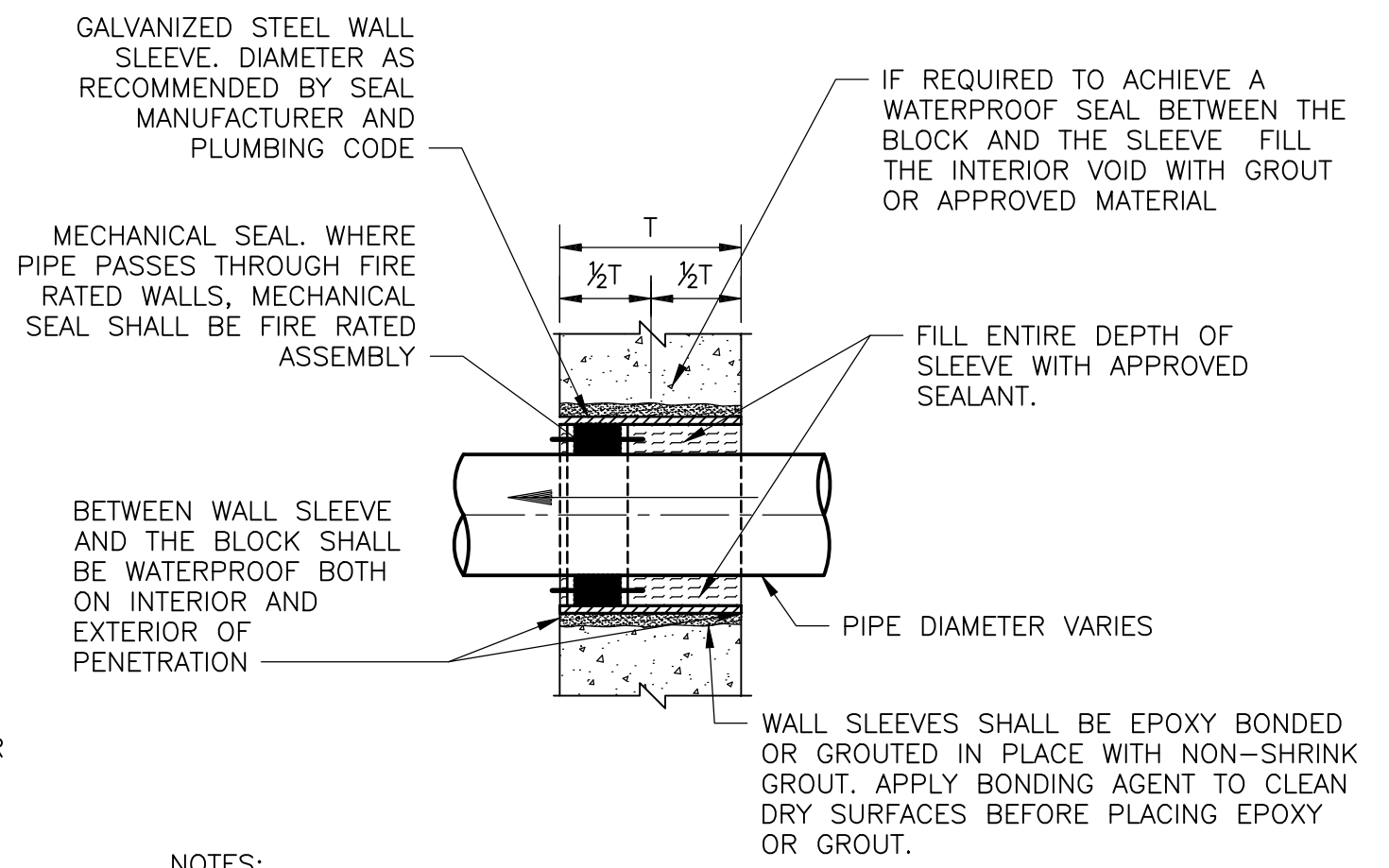

- NOTES:**
1. PIPE PENETRATIONS AND SLEEVE SHALL BE IN ACCORDANCE WITH RHODE ISLAND PLUMBING CODE.
 2. SEAL SHALL BE PLACE IN ACCORDANCE TO MANUFACTURERS RECOMMENDATION.

WALL SLEEVE WITH MECHANICAL SEAL FOR
CONCRETE, BRICK CMU OR CAVITY WALLS
DETAIL
 NTS

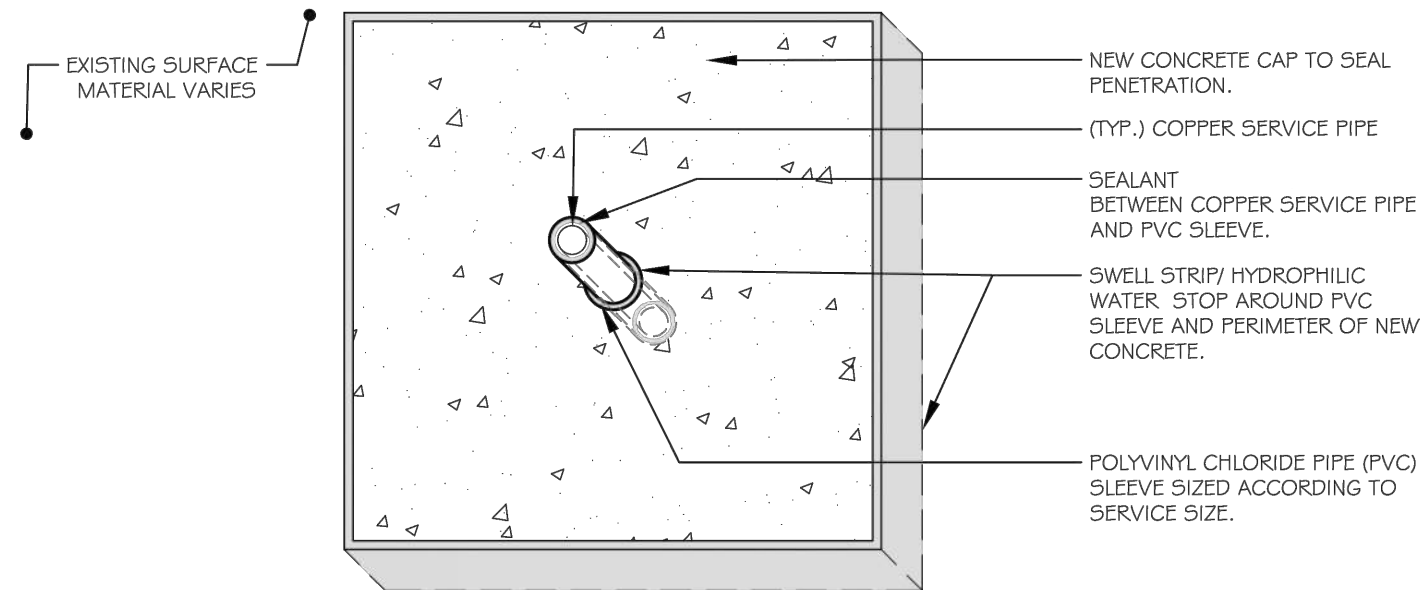

ISOMETRIC PLAN VIEW ENLARGEMENT
NTS

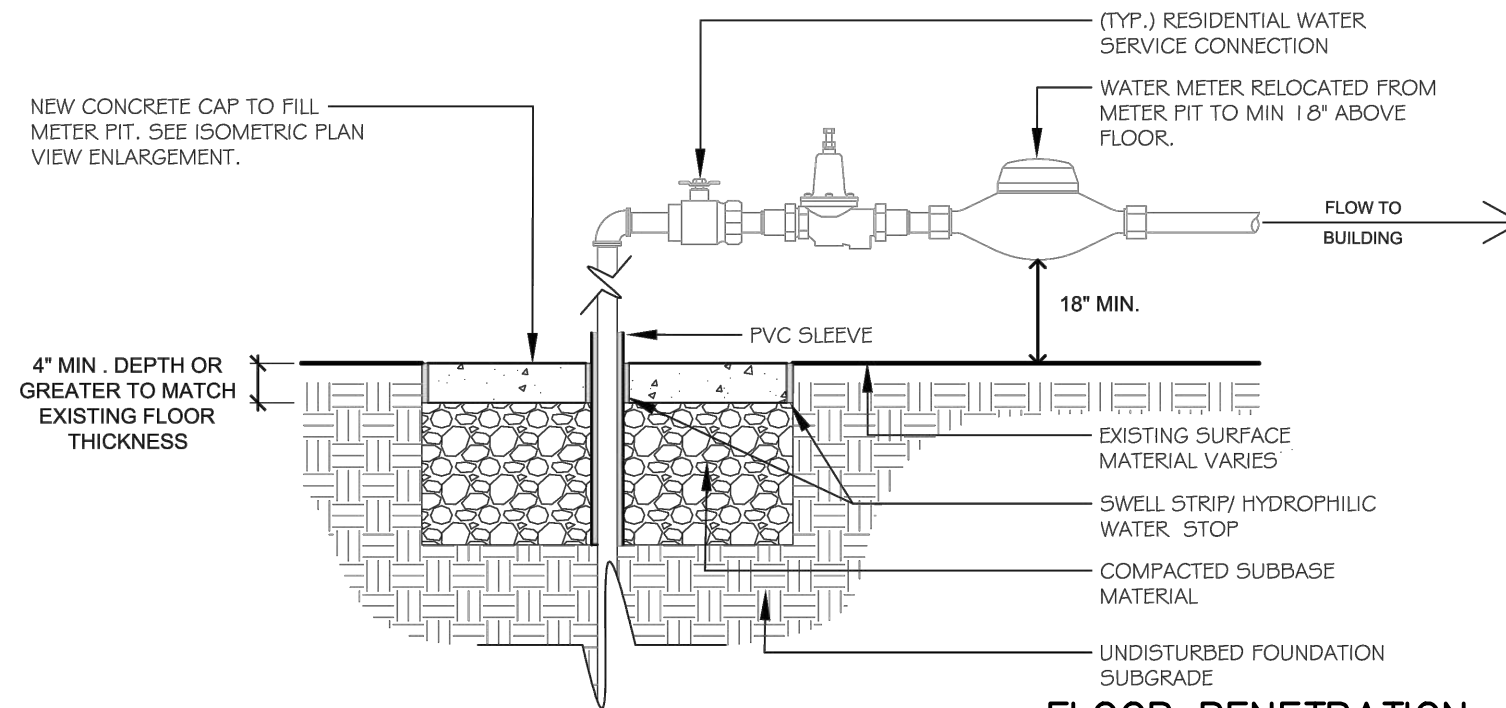

SECTION/ELEVATION
NTS

FLOOR PENETRATION
DETAIL
NTS

GENERAL NOTES:

1. CONTRACTOR SHALL PROVIDE ALL MATERIALS, EQUIPMENT, TOOLS, LABOR, SERVICES, APPURTENANCES, AND INCIDENTALS TO COMPLETE ALL REQUIRED WORK AS SHOWN AND AS SPECIFIED.
2. SERVICE PIPE SLEEVED INSIDE PVC. FILL SPACE BETWEEN WITH SEALANT
3. METER PIT TO BE BACKFILLED WITH SUITABLE COMPACTED BASE MATERIAL AND FINISHED WITH MINIMUM 4" CONCRETE OR GREATER TO MATCH EXISTING FLOOR.
4. SWELL STRIP TO BE INSTALLED AT ALL JOINTS OF NEW AND OLD CONCRETE.
5. EXISTING MATERIALS REMOVED DURING CONSTRUCTION (THAT ARE NOT FOR REUSE) SHALL BE REMOVED AND DISPOSED OF BY THE CONTRACTOR AS REQUIRED AND SPECIFIED AND IN ACCORDANCE WITH ALL FEDERAL, STATE, AND LOCAL LAWS, REGULATIONS, AND/OR REQUIREMENTS.
6. CONTRACTOR IS RESPONSIBLE FOR REPAIRING ANY DAMAGE CAUSED BY THE CONTRACTOR TO ANY ADJACENT UTILITIES AND ANY ITEMS ON PRIVATE PROPERTY.
7. SERVICE PIPE'S ENTERING BUILDING THROUGH FOUNDATION WALL SHALL BE INSTALLED IN PVC SLEEVE WITH SEALANT AND SWELL STRIPS AND PENETRATION SEALED WITH CONCRETE. SAME AS SHOWN IN ISOMETRIC ENLARGEMENT VIEW. (EXCEPT THIS WOULD BE FOUNDATION WALL).

SOURCE: PROVIDENCE WATER SUPPLY BOARD



CITY OF PROVIDENCE, RHODE ISLAND
PROVIDENCE WATER SUPPLY BOARD
ACCELERATED LEAD SERVICE LINE REPLACEMENT PROGRAM
CONTRACT 1.4

Detail No. 5

MARCH 2024

XREFs: [CITY OF PROVIDENCE TEMPORARY ROADWAY RESTORATION]
Last saved by: CABRERAJG Time: 6/28/2023 11:09:16 PM
C:\pw_pl1\cabrerajg\3271389\DETAIL 6.dwg

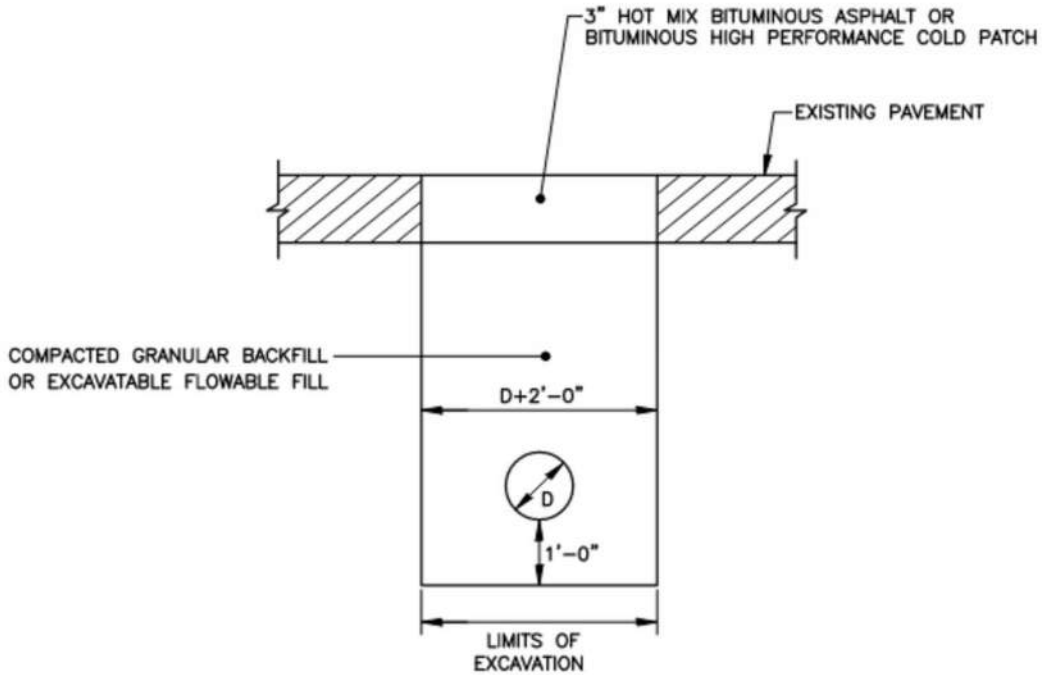

NOTES:

1. BITUMINOUS CONCRETE SHALL ADHERE TO RIDOT STANDARD SPECIFICATIONS, SECTION 401.
2. GRANUAL BASE MATERIAL SHALL BE COMPACTED TO 95% OF MODIFIED PROCTOR DENSITY (AASHTO T180), AND SHALL ADJERE TO RIDOT STANDARD SPECIFICATIONS, SECTION 301.
3. EXCAVATABLE FLOWABLE FILL (CONTROLLED DENSITY FILL. CDF) SHALL ADHERE TO RIDOT STANDARD SPECIFICATIONS, SECTION 603.
4. ANY TEMPORARY PATCH INSTALLED PRIOR TO SEPTEMBER 1 IN ANY YEAR SHALL BE REPLACED WITH PERMANENT PATCH NO LATER THAN DECEMBER 1 OF THAT YEAR.
5. IF TEMPORARY PATCH IS INSTALLED, PERMITEE MAY ALLOW NO MORE THAN 45 DAYS FOR SETTLING BEFORE PERMANENT RESTORATION. THE PERMITEE SHALL BE RESPONSIBLE TO MAINTAIN TEMPORARY ROADWAY RESTORATIONS IN A SAFE CONDITION FOR ALL TYPES OF TRAVEL UNTIL A PERMANENT PAVEMENT REPAIR HAS BEEN MADE. TO ENSURE PROPER MAINTENANCE, THE PERMITEE SHALL PERFORM PERIODIC INSPECTION OF EACH TEMPORARY PATCH UNTIL IT IT REPLACED WITH A PERMANENT PATCH.
6. FOR ROADS UNDER STATE JURISDICTION AND MAINTENANCE, RESTORATION MUST BE IN ACCORDANCE WITH RIDOT STANDARD SPECIFICATIONS SECTION 410.

TEMPORARY ROADWAY RESTORATION

NOT TO SCALE

SOURCE: PROVIDENCE DEPARTMENT OF PUBLIC WORKS



CITY OF PROVIDENCE, RHODE ISLAND
PROVIDENCE WATER SUPPLY BOARD
ACCELERATED LEAD SERVICE LINE
REPLACEMENT PROGRAM
CONTRACT 1.4

Detail No. 6

MARCH 2024

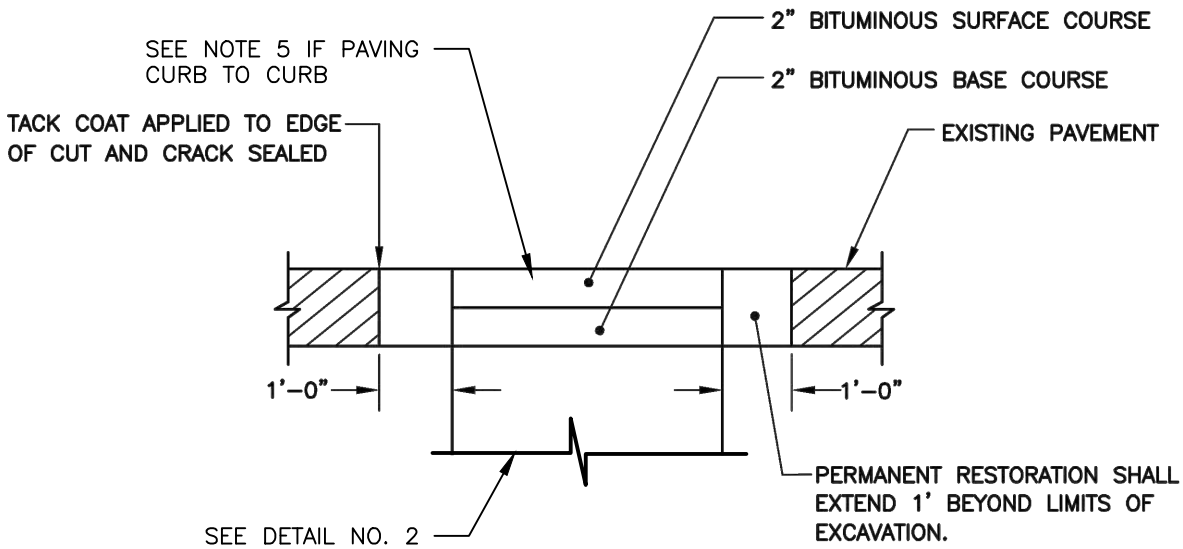

NOTES:

1. BITUMINOUS CONCRETE SHALL ADHERE TO RIDOT STANDARD SPECIFICATIONS, SECTION 401.
2. BACKFILL MATERIAL SHALL BE COMPACTED TO 95% OF MODIFIED PROCTOR DENSITY (AASHTO T180), AND SHALL ADHERE TO RIDOT STANDARD SPECIFICATIONS, SECTION 301.
3. EXCAVATABLE FLOWABLE FILL (CONTROLLED DENSITY FILL. CDF) SHALL ADHERE TO RIDOT STANDARD SPECIFICATIONS, SECTION 603.
4. PRIOR TO PERMANENT RESTORATION, ALL EDGES OF THE EXCAVATED AREA AND ONE FOOT BEYOND SHALL BE SAWCUT TO A CLEAN, SQUARE EDGE.
5. IF STREET TO BE PAVED CURB TO CURB, THE REMAINING ROADWAY OUTSIDE THE TRENCH TO THE NEAREST CURB SHALL BE MILLED 2 INCHES WITH 2 INCH BITUMINOUS CONCRETE SURFACE OVERLAY. THE JOINTS SHALL BE SEALED USING INFRARED TECHNOLOGY. THE LENGTH OF THE NEW PAVED AREA MUST BE MINIMUM OF 10 FEET TO ALLOW FOR PROPER ROLLING.
6. IF THE DISTANCE FROM EDGE OF EXCAVATION TO EDGE OF ROADWAY IS 2 FEET OR LESS, THE REMAINING AREA TO EDGE OF ROADWAY SHALL BE REMOVED AND REPLACED IN CONJUNCTION WITH THE PERMANENT ROADWAY RESTORATION.
7. FOR ROADS UNDER STATE JURISDICTION AND MAINTENANCE, RESTORATION MUST BE IN ACCORDANCE WITH RIDOT STANDARD SPECIFICATIONS SECTION 401.04.
8. PERMANENT RESTORATION WILL ONLY BE REQUIRED FOR ROADS LISTED IN APPENDIX C.

PERMANENT ROADWAY RESTORATION - GRANULAR BASE

NOT TO SCALE

SOURCE: PROVIDENCE DEPARTMENT OF PUBLIC WORKS

XREFs: [] Images: []
 Last saved by: CABRERAJG Time: 6/28/2023 11:09:03 PM
 C:\pw_pl1\cabrerajg\3271389\DETAIL 7a.dwg



CITY OF PROVIDENCE, RHODE ISLAND
 PROVIDENCE WATER SUPPLY BOARD
 ACCELERATED LEAD SERVICE LINE
 REPLACEMENT PROGRAM
 CONTRACT 1.4

Detail No. 7a

MARCH 2024

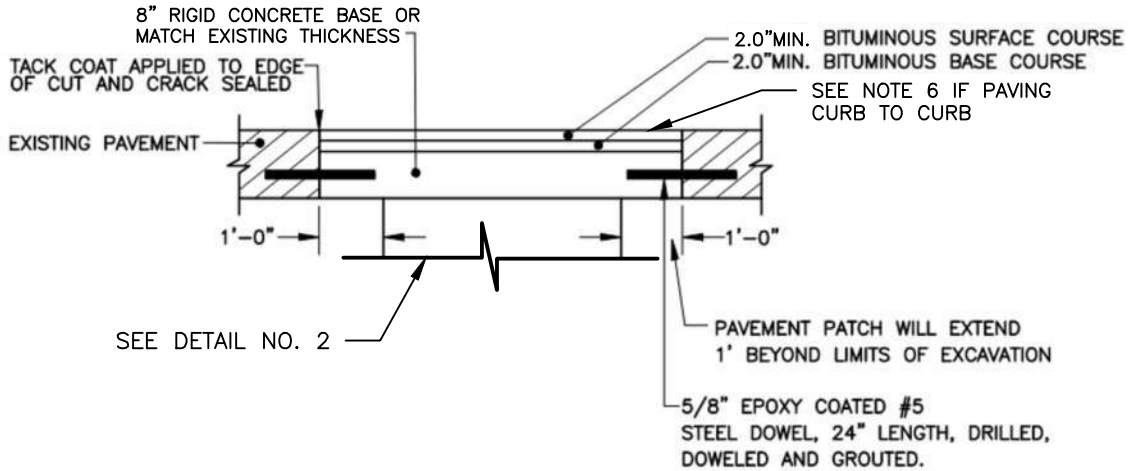

NOTES:

1. CONCRETE ROAD BASE MUST BE RESTORED TO THE EXISTING DEPTH OR A MINIMUM OF 8 INCHES. A MINIMUM OF 3.5 INCHES OF BITUMINOUS CONCRETE SURFACE COURSE MEETING RIDOT SPECIFICATIONS, SECTION 401 SHALL BE PLACED OVER BASE.
2. 8 INCH RIGID CONCRETE BASE SHALL BE TYPE XX (28 DAY -4000 PSI) PER RIDOT SPECIFICATIONS, SECTION 601.
3. PRIOR TO PERMANENT RESTORATION, ALL EDGES OF THE EXCAVATED AREA AND ONE FOOT BEYOND SHALL BE SAWCUT TO A CLEAN, SQUARE EDGE.
4. BACKFILL MATERIAL SHALL BE COMPACTED TO 95% OF MODIFIED PROCTOR DENSITY (AASHTO T180), AND SHALL ADHERE TO RIDOT STANDARD SPECIFICATIONS, SECTION 301.
5. EXCAVATABLE FLOWABLE FILL (CONTROLLED DENSITY FILL, CDF) SHALL ADHERE TO RIDOT SPECIFICATIONS, SECTION 603.
6. THE REMAINING ROADWAY OUTSIDE THE TRENCH TO THE NEAREST CURB SHALL BE MILLED 2 INCHES WITH A 2 INCH BITUMINOUS CONCRETE SURFACE OVERLAY. THE JOINTS SHALL BE SEALED USING INFRARED TECHNOLOGY. THE LENGTH OF THE NEW PAVED AREA MUST BE A MINIMUM OF 10 FEET TO ALLOW FOR PROPER COMPACTION.
7. IF THE DISTANCE FROM EDGE OF EXCAVATION TO EDGE OF ROADWAY IS 2 FEET OR LESS, THE REMAINING AREA TO EDGE OF ROADWAY SHALL BE REMOVED AND REPLACED IN CONJUNCTION WITH THE PERMANENT ROADWAY RESTORATION.

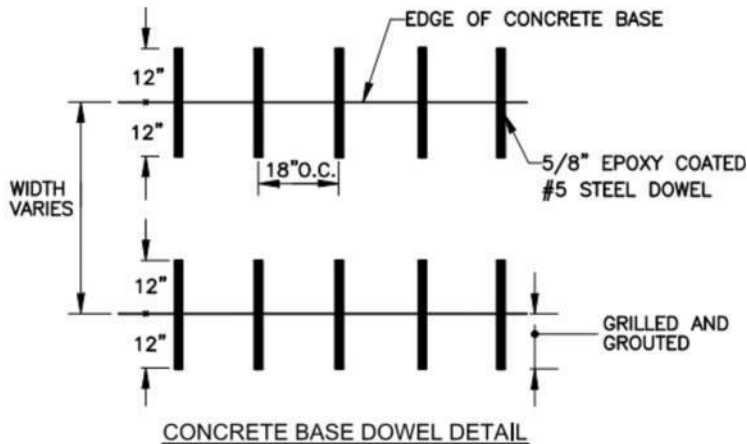

NOTES:

1. DOWEL SHALL BE INSTALLED 4" FROM SURFACE OF CONCRETE BASE.
2. THE EXISTING CONCRETE ROAD BASE SHALL BE DRILLED AND GROUTED EVERY 18" ON CENTER TO RECEIVE THE EPOXY COATED STEEL DOWELS.

PERMANENT ROADWAY RESTORATION - CONCRETE BASE

NOT TO SCALE

SOURCE: PROVIDENCE DEPARTMENT OF PUBLIC WORKS



CITY OF PROVIDENCE, RHODE ISLAND
 PROVIDENCE WATER SUPPLY BOARD
 ACCELERATED LEAD SERVICE LINE
 REPLACEMENT PROGRAM
 CONTRACT 1.4

Detail No. 7b

MARCH 2024

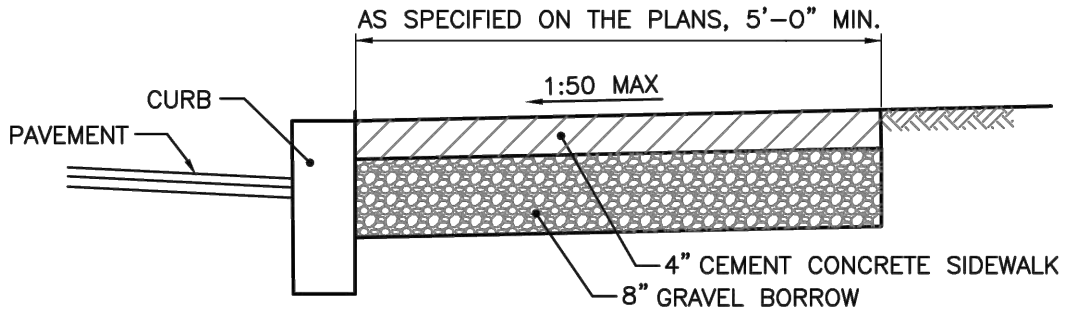

NOTES

1. SHALL BE IN ACCORDANCE WITH SECTION 905 OF THE R.I. STANDARD SPECIFICATIONS.
2. SEE CURB SETTING DETAIL WHERE APPLICABLE.
3. RUNNING SLOPE OF SIDEWALK SHALL NOT EXCEED 8.3% (1:12). TYPICALLY, RUNNING SLOPE SHALL MATCH ROAD SLOPE.
4. CROSS SLOPE OF SIDEWALK SHALL NOT EXCEED 2% (1:50).
5. SIDEWALK MAY BE SUBJECT TO GRASS STRIP INSTALLATION. CONSULT WITH DPW ENGINEERING
6. GRAVEL BORROW BASE SHALL COMPACT TO ACHEIVE SOIL DENSITY VALUES OF 95% MODIFIED PROCTOR DENSITY (AASHTO T180).
7. SIDEWALK REPAIRS TWENTY FEET OR LONGER ARE SUBJECT TO REQUIREMENTS HEREIN. SIDEWALK REPAIRS SHORTER THAN TWENTY FEET SHALL MAKE EVERY EFFORT TO MEET REQUIRED SLOPES.
8. CONTROLL JOINTS SHALL BE INSTALLED EVERY 5 FEET IN EACH DIRECTION.
9. EXPANSION JOINTS SHALL BE INSTALLED EVERY 20 FEET IN EACH DIRECTION AT FOUNDATIONS AND WALLS AND IN A SQUARE PATTERN AROUND MANHOLE COVERS, HYDRANTS, SIGN POSTS AND UTILITY POLES. THE EXPANSION JOINT SHALL BE THE FULL DEPTH OF THE SIDEWALK AND FILLED WITH AN APPROVED TYPE OF PREMOLDED EXPANSION JOINT FILLER.

CEMENT CONCRETE SIDEWALK - MUNICIPAL ROADS

NOT TO SCALE

SOURCE: PROVIDENCE DEPARTMENT OF PUBLIC WORKS

XREFs: [] Images: []
 Last saved by: CABRERAJG Time: 6/29/2023 9:13:35 AM
 C:\pw_pl1\cabrerajg\3271389\DETAIL 8.dwg



CITY OF PROVIDENCE, RHODE ISLAND
 PROVIDENCE WATER SUPPLY BOARD
 ACCELERATED LEAD SERVICE LINE
 REPLACEMENT PROGRAM
 CONTRACT 1.4

Detail No. 8

MARCH 2024

XREFs: [] Images: []
Last saved by: CABRERAJG Time: 6/29/2023 9:13:41 AM
C:\pw_pl1\cabrerajg\3271389\DETAIL 9.dwg

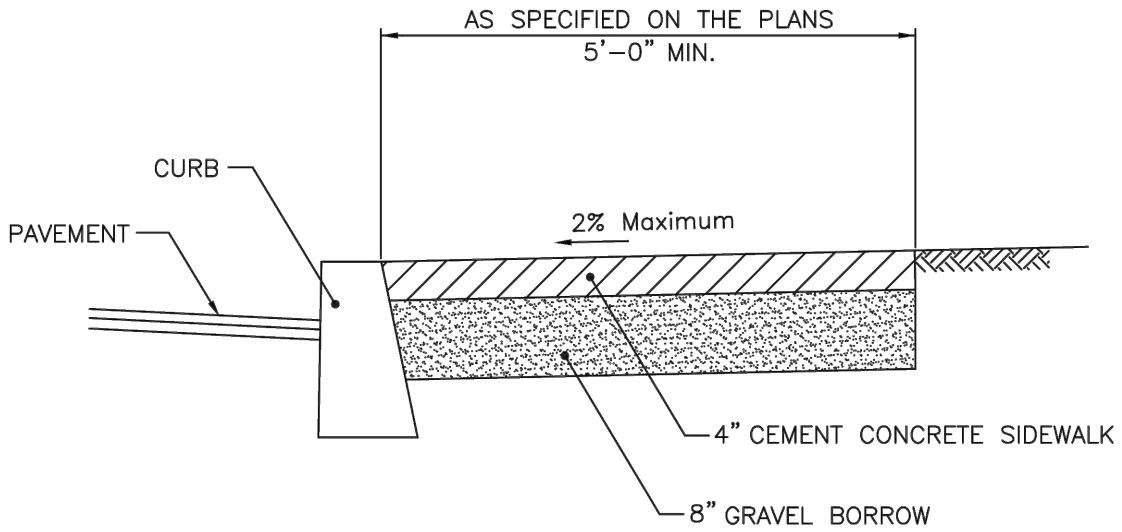

NOTES

1. SHALL BE IN ACCORDANCE WITH SECTION 905 OF THE R.I. STANDARD SPECIFICATIONS.
2. FOR CURB SETTING DETAIL REFERENCE STD. 7.6.0.

CEMENT CONCRETE SIDEWALK - STATE ROADS

NOT TO SCALE

SOURCE: RHODE ISLAND DEPARTMENT OF TRANSPORTATION



CITY OF PROVIDENCE, RHODE ISLAND
PROVIDENCE WATER SUPPLY BOARD
ACCELERATED LEAD SERVICE LINE
REPLACEMENT PROGRAM
CONTRACT 1.4

Detail No. 9

MARCH 2024

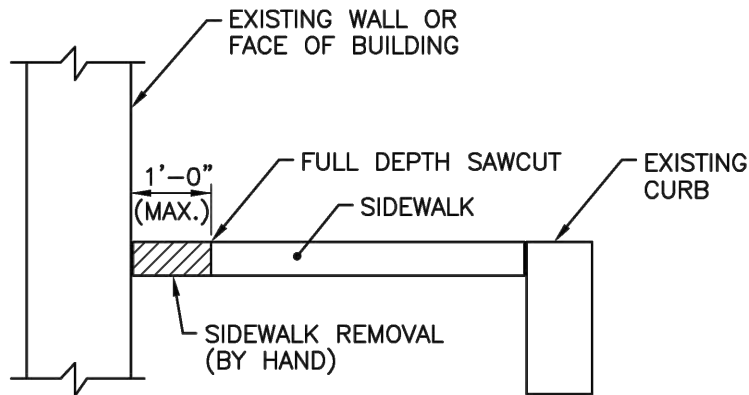

SIDEWALK REMOVAL

NOT TO SCALE

NOTES:

1. IN AREAS WHERE SIDEWALKS ARE TO BE REMOVED IN FRONT OF EXISTING WALLS OR BUILDINGS, THE CONTRACTOR SHALL SAWCUT ONE(1) FOOT (MAXIMUM) IN FRONT OF THE WALL/BUILDING AND REMOVE THE SIDEWALK STRUCTURE BY HAND.
2. IN THE EVENT THAT THE EXISTING SIDEWALK IS A STRUCTURAL ELEMENT OF THE WALL/BUILDING, THE EXISTING SIDEWALK IN FRONT OF THESE STRUCTURES WILL REMAIN IN-PLACE AND A NEW SIDEWALK CONSTRUCTED TO MATCH THE EXISTING SECTION.
3. ANY DAMAGE TO THE WALL OR BUILDING BY THE CONTRACTOR SHALL BE REPAIRED BY THE CONTRACTOR AT NO ADDITIONAL COST TO THE CITY.

SOURCE: PROVIDENCE DEPARTMENT OF PUBLIC WORKS

XREFs: [] Images: []
 Last saved by: CABRERAJG Time: 6/29/2023 9:14:00 AM
 C:\pw_pl1\cabrerajg\3271389\DETAIL 10.dwg



CITY OF PROVIDENCE, RHODE ISLAND
 PROVIDENCE WATER SUPPLY BOARD
 ACCELERATED LEAD SERVICE LINE
 REPLACEMENT PROGRAM
 CONTRACT 1.4

Detail No. 10

MARCH 2024

XREFs: [] Images: []
Last saved by: CABRERAJG Time: 6/29/2023 9:14:07 AM
C:\pw_pl1\cabrerajg\3271389\DETAIL 11.dwg

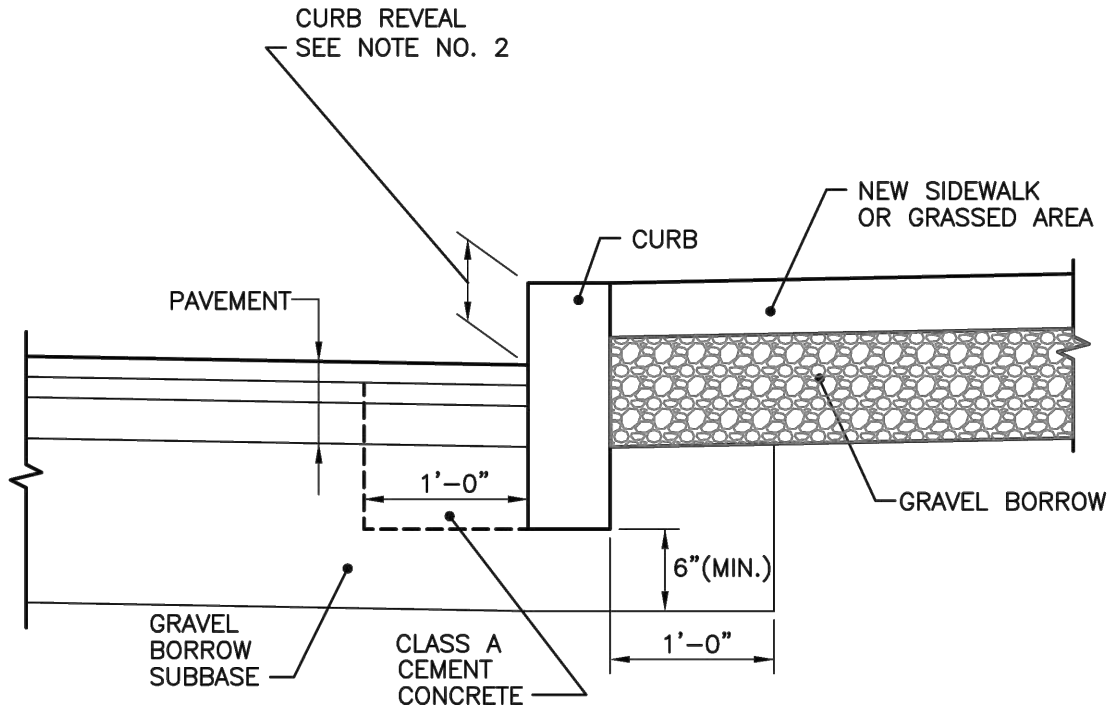

NOTES:

1. SHALL BE IN ACCORDANCE WITH SECTION 906 OF THE R.I. STANDARD SPECIFICATIONS.
2. NEW CURBING CONSTRUCTION SHALL BE SET AT A 6 INCH REVEAL OR AS INDICATED ON PLANS OR DIRECTED BY PROVIDENCE DPW. NEW CURBING INSTALLED ADJACENT TO EXISTING CURBING SHALL MATCH THE EXISTING REVEAL OR A MINIMUM OF 4 INCHES, WHICHEVER IS GREATER. IF ADJACENT EXISTING REVEAL IS LESS THAN 4 INCHES, THE FIRST SECTION OF NEW CURB SHALL TRANSITION TO 4" REVEAL,
3. LIFT ANY SUNKEN CURBS AND COMPACT TO BE LEVEL WITH THE TOP OF SIDEWALK.

CURB SETTING

NOT TO SCALE

SOURCE: PROVIDENCE DEPARTMENT OF PUBLIC WORKS



CITY OF PROVIDENCE, RHODE ISLAND
PROVIDENCE WATER SUPPLY BOARD
ACCELERATED LEAD SERVICE LINE
REPLACEMENT PROGRAM
CONTRACT 1.4

Detail No. 11

MARCH 2024

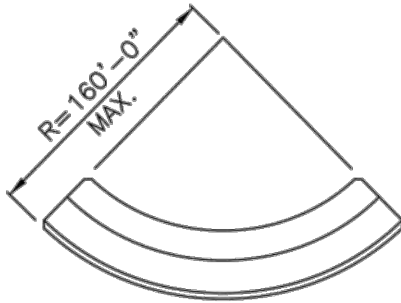
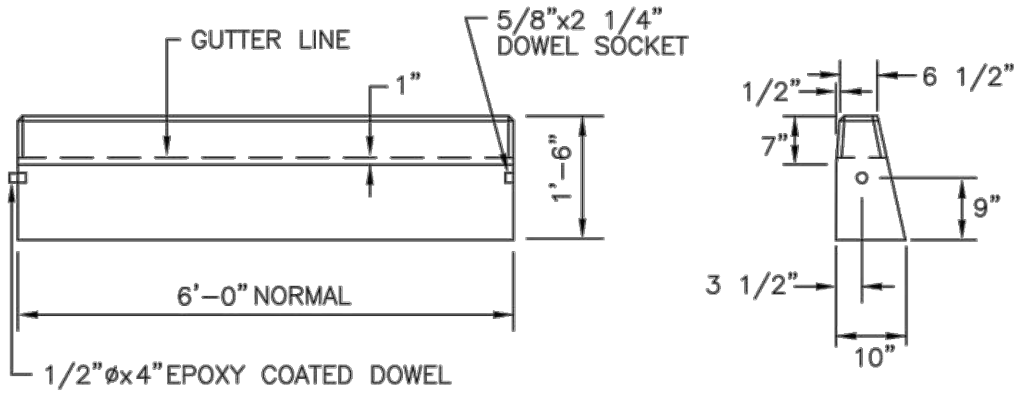

CIRCULAR CURB

PRECAST CONCRETE CURB

NOT TO SCALE

NOTES:

1. SHALL BE IN ACCORDANCE WITH SECTION 906 OF THE R.I. STANDARD SPECIFICATIONS.
2. MINIMUM LENGTH OF STRAIGHT OR CIRCULAR FILLER PEICES TO BE 3'-0". EXPOSED SURFACES TO HAVE A SPONGE FLOAT FINISH.
3. CIRCULAR CURB IS REQUIRED ON CURVES WITH RADII OF 160'-0" OR LESS. STRAIGHT CURB TO BE USED ON CURVES OF MORE THAN 160'-0" RADIUS.
4. EXPOSED EDGES TO HAVE A 3/4" CHAMFER.

SOURCE: PROVIDENCE DEPARTMENT OF TRANSPORTATION



CITY OF PROVIDENCE, RHODE ISLAND
 PROVIDENCE WATER SUPPLY BOARD
 ACCELERATED LEAD SERVICE LINE
 REPLACEMENT PROGRAM
 CONTRACT 1.4

Detail No. 12

MARCH 2024

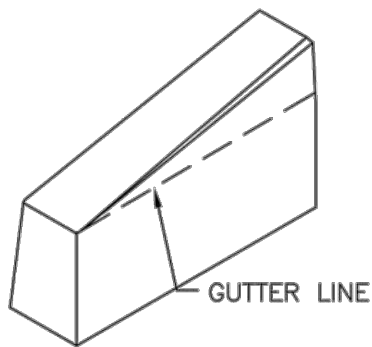
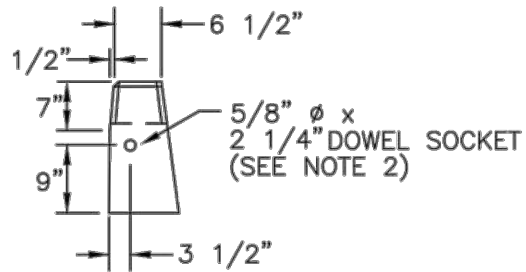
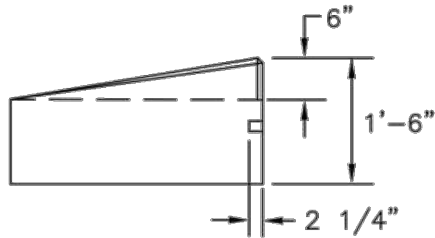
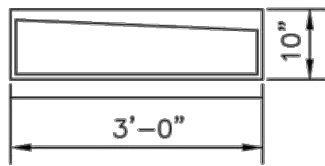

3'-0" PRECAST CONCRETE TRANSITION CURB

NOT TO SCALE

NOTES:

1. SHALL BE IN ACCORDANCE WITH SECTION 906 OF THE R.I. STANDARD SPECIFICATIONS.
2. DRAWING SHOWS TRANSITION CURB FOR ONE DIRECTION, FOR OTHER DIRECTION USE OPPOSITE HAND AND INCLUDE A 1/2" ϕ x 4" EPOXY COATED DOWEL.
3. EXPOSED SURFACES TO HAVE A SPONGE FLOAT FINISH.
4. EXPOSED EDGES TO HAVE A 3/4" CHAMFER.
5. LEFT AND RIGHT SECTIONS SHALL BE INSTALLED AS REQUIRED.

SOURCE: PROVIDENCE DEPARTMENT OF TRANSPORTATION

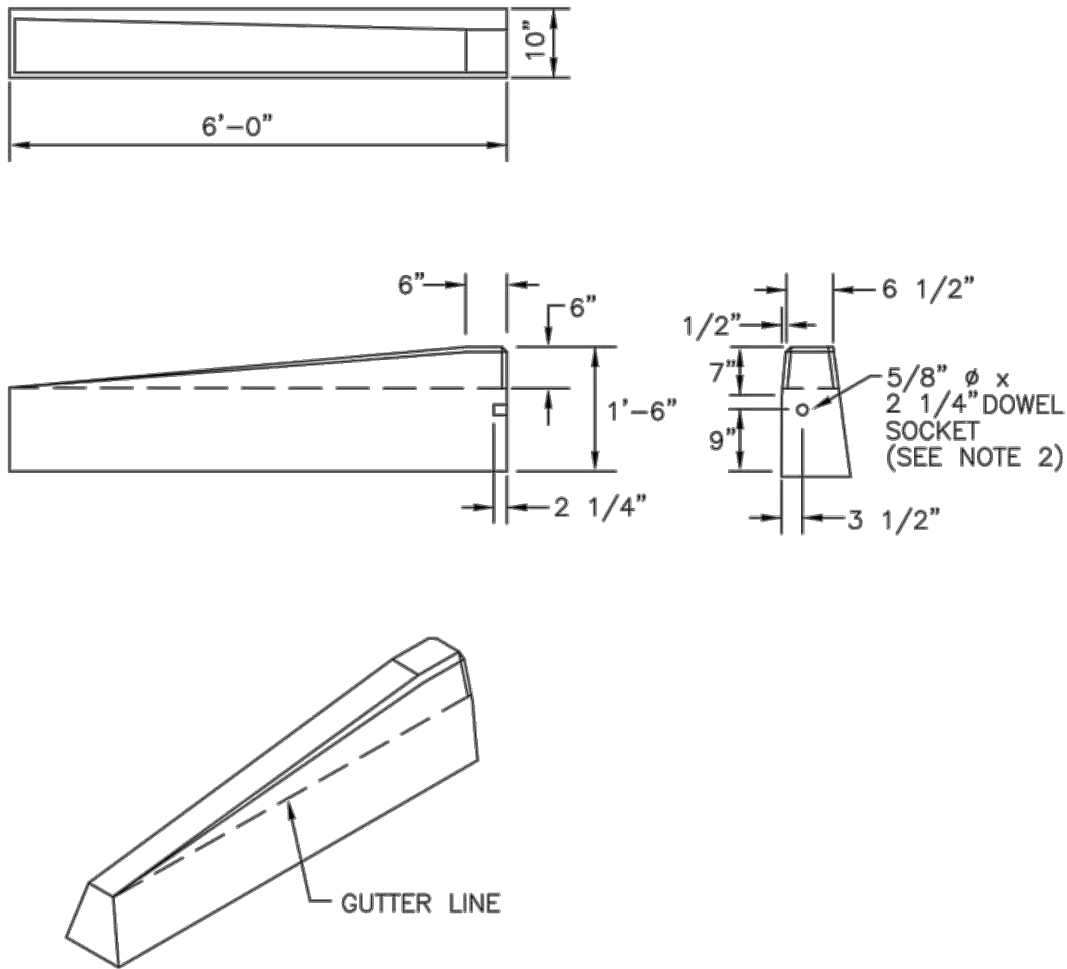

6'-0" PRECAST CONCRETE TRANSITION CURB

NOT TO SCALE

NOTES:

1. SHALL BE IN ACCORDANCE WITH SECTION 906 OF THE R.I. STANDARD SPECIFICATIONS.
2. DRAWING SHOWS TRANSITION CURB FOR ONE DIRECTION. FOR OTHER DIRECTION USE OPPOSITE HAND AND INCLUDE A 1/2" ϕ x 4" EPOXY COATED DOWEL.
3. EXPOSED SURFACES TO HAVE A SPONGE FLOAT FINISH.
4. EXPOSED EDGES TO HAVE A 3/4" CHAMFER.

SOURCE: PROVIDENCE DEPARTMENT OF TRANSPORTATION



CITY OF PROVIDENCE, RHODE ISLAND
 PROVIDENCE WATER SUPPLY BOARD
 ACCELERATED LEAD SERVICE LINE
 REPLACEMENT PROGRAM
 CONTRACT 1.4

Detail No. 14

MARCH 2024

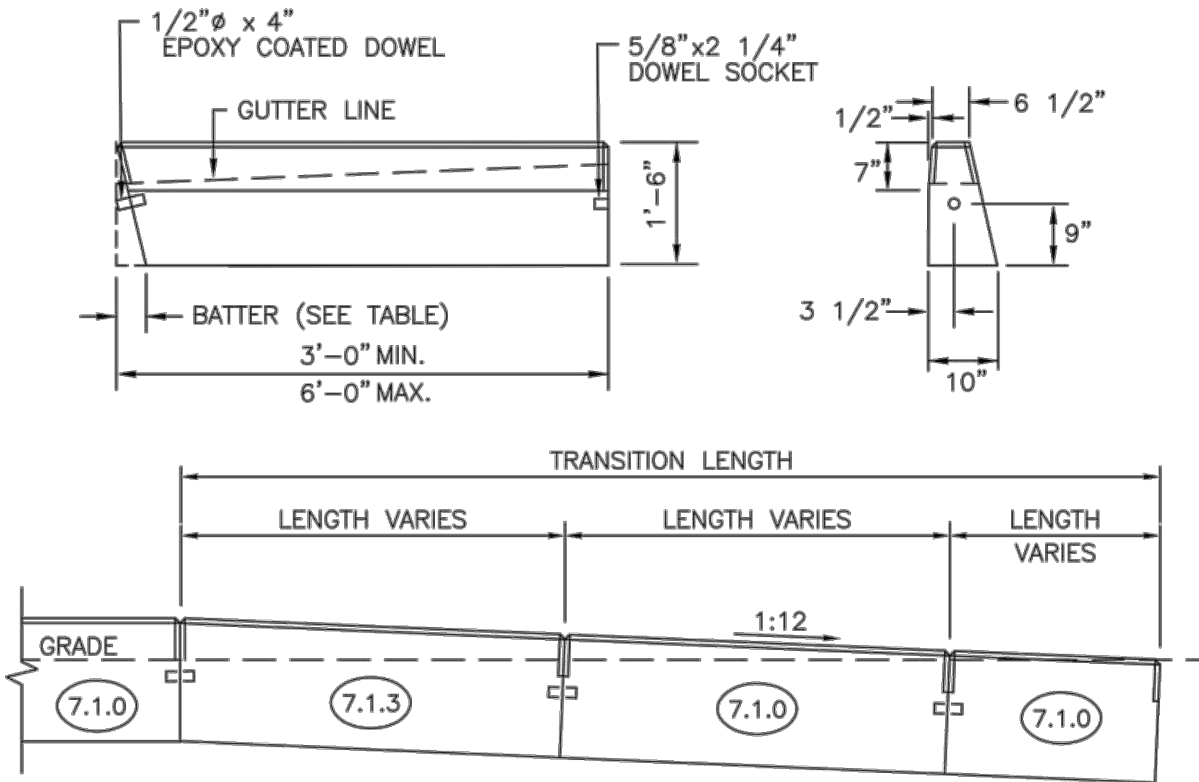

TRANSITION LENGTH (FT.)	BATTER (IN.)
6.0	1.5
7.0	1.3
8.0	1.2
9.5	1.0
11.5	0.8
15.0	0.6
18.0	0.5

PRECAST CONCRETE WHEELCHAIR TRANSITION CURB

NOT TO SCALE

NOTES:

1. SHALL BE IN ACCORDANCE WITH SECTION 906 OF THE R.I. STANDARD SPECIFICATIONS.
2. CIRCULAR CURB IS REQUIRED ON CURVES WITH RADII OF 160'-0" OR LESS. STRAIGHT CURB TO BE USED ON CURVES OF MORE THAN 160'-0" RADIUS.
3. EXPOSED EDGES TO HAVE A 3/4" CHAMFER.
4. EXPOSED SURFACES TO HAVE A SPONGE FLOAT FINISH.
5. MINIMUM LENGTH OF STRAIGHT OR CIRCULAR CURB FILLER PIECES TO BE 3'-0" (GREATER LENGTHS PREFERRED).

SOURCE: PROVIDENCE DEPARTMENT OF TRANSPORTATION

XREFs: [CITY OF PROVIDENCE CEMENT CONCRETE DRIVEWAYS]
 Last saved by: CABRERAJG Time: 6/29/2023 11:30:00 AM
 C:\pw_p1\cabrerajg\3271389\DETAIL 16.dwg

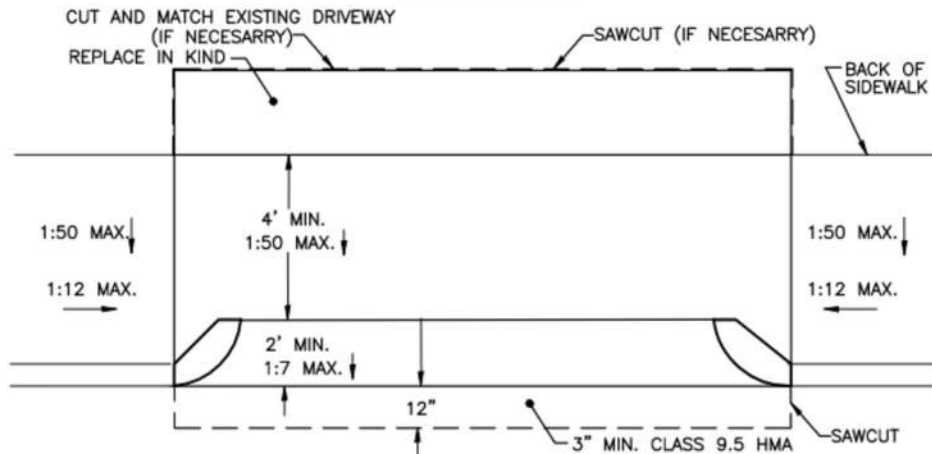
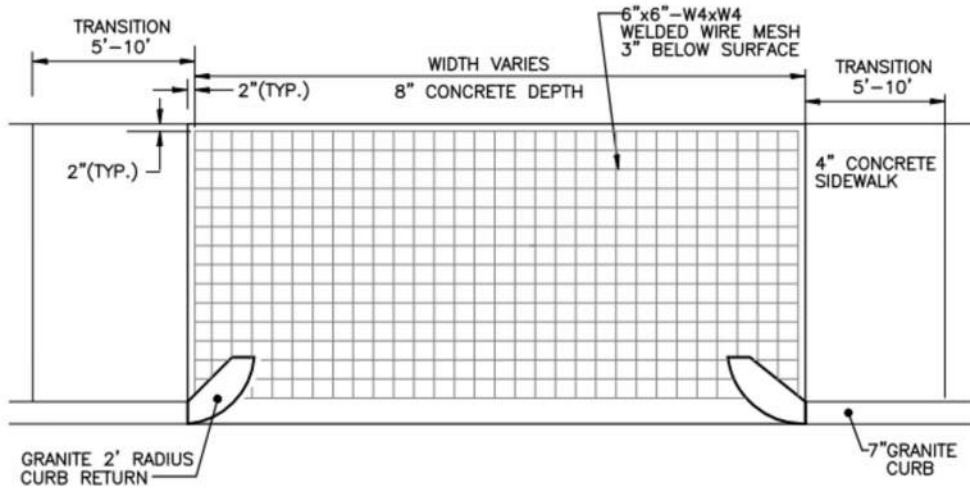

CEMENT CONCRETE DRIVEWAYS

NOTES:

NOT TO SCALE

1. SHALL BE IN ACCORDANCE WITH SECTION 905 OF THE RIDOT STANDARD SPECIFICATIONS.
2. RUNNING SLOPE OF SIDEWALK/DRIVEWAY SHALL NOT EXCEED 8.3% (1:12).
3. 4" MINIMUM ACCESSIBLE PATH SHALL BE INSTALLED WITH CROSS SLOPE NOT EXCEEDING 2% (1:50).
4. RESIDENTIAL CURB CUTS SHALL NE NO WIDER THAN 12' FROM INSIDE OF CURB RETURNS.

SOURCE: PROVIDENCE DEPARTMENT OF PUBLIC WORKS



CITY OF PROVIDENCE, RHODE ISLAND
 PROVIDENCE WATER SUPPLY BOARD
 ACCELERATED LEAD SERVICE LINE
 REPLACEMENT PROGRAM
 CONTRACT 1.4

Detail No. 16

MARCH 2024

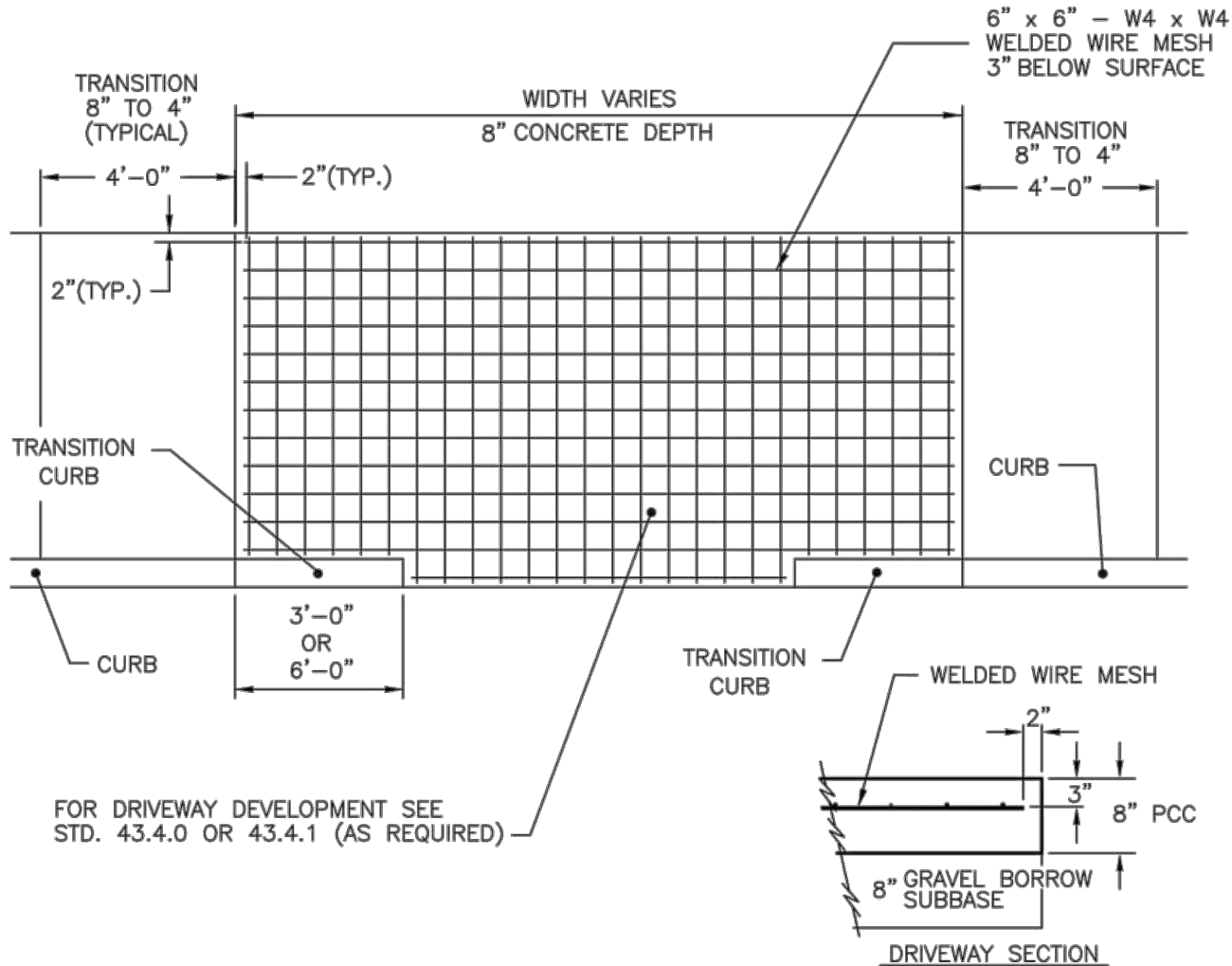

CEMENT CONCRETE DRIVEWAYS

NOT TO SCALE

NOTE:

1. SHALL BE IN ACCORDANCE WITH SECTION 905 OF THE R.I. STANDARD SPECIFICATIONS.

SOURCE: PROVIDENCE DEPARTMENT OF TRANSPORTATION

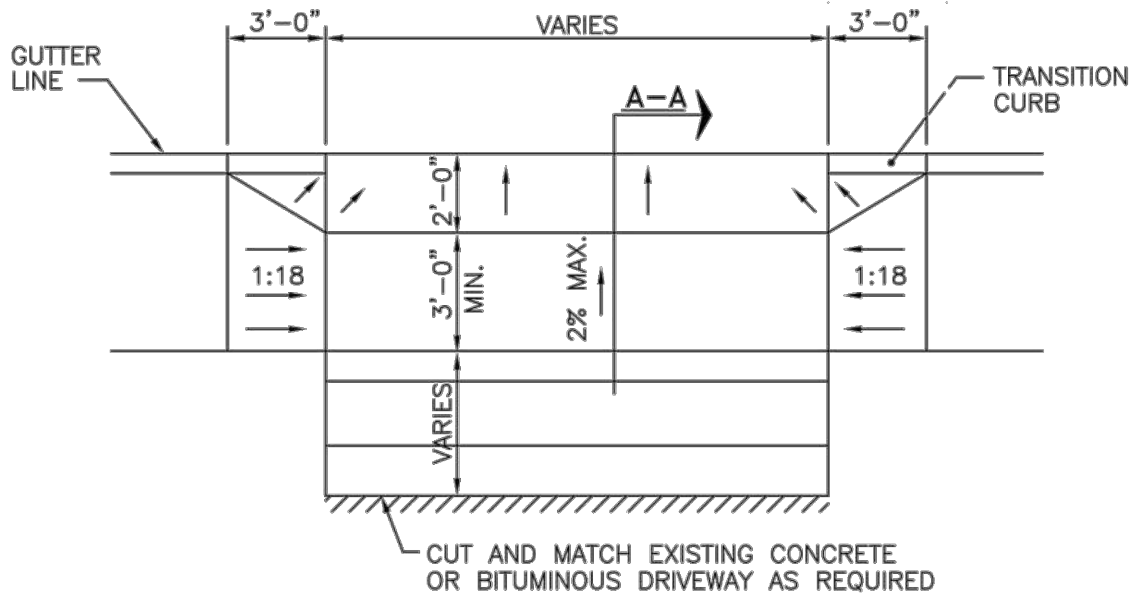

PLAN



ELEVATION

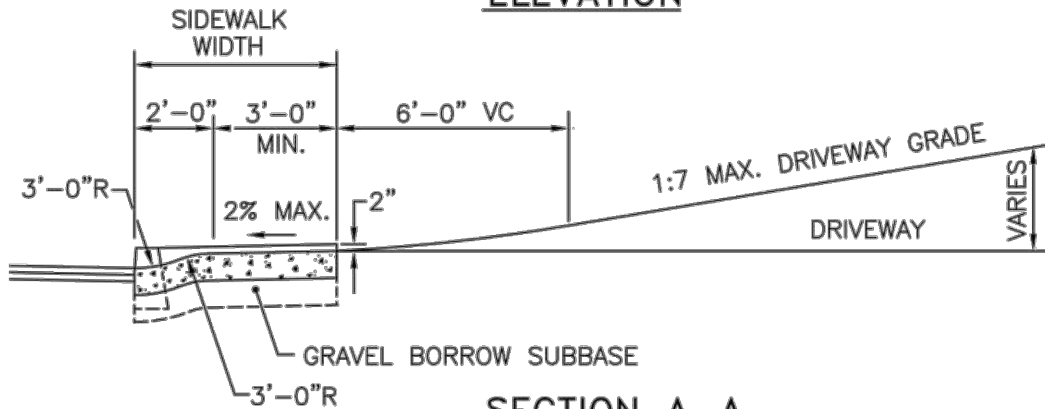

SECTION A-A

DRIVEWAY DEVELOPMENT FOR 3'-0" TRANSITION CURB

NOT TO SCALE

NOTES:

1. SHALL BE IN ACCORDANCE WITH SECTION 905 OF THE R.I. STANDARD SPECIFICATIONS.
2. WHEN DRIVEWAY IS BELOW BACK EDGE OF SIDEWALK PROFILE, STD. 43.4.1 MUST BE USED.

SOURCE: PROVIDENCE DEPARTMENT OF TRANSPORTATION

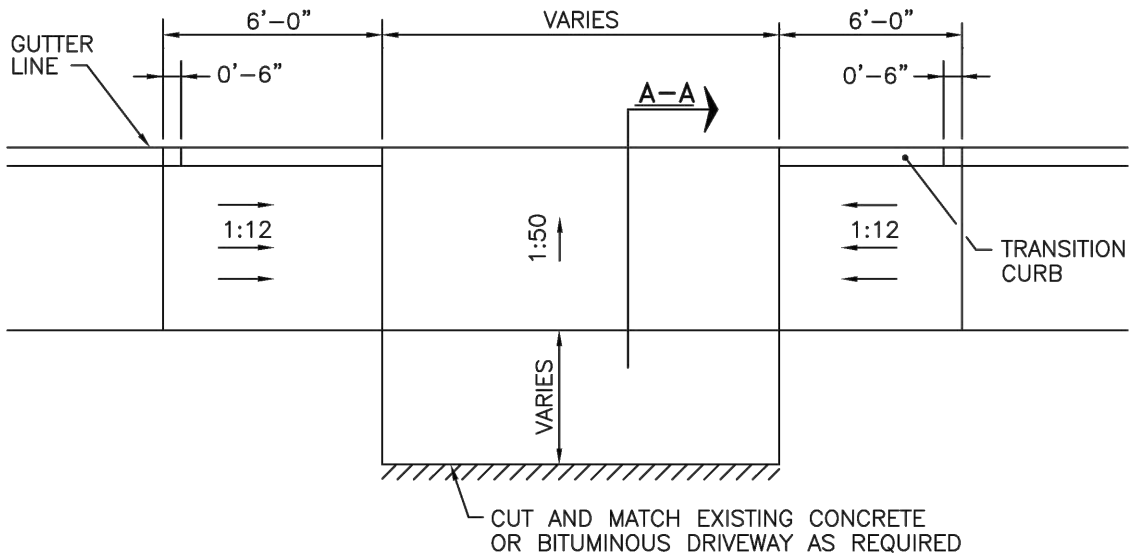

PLAN

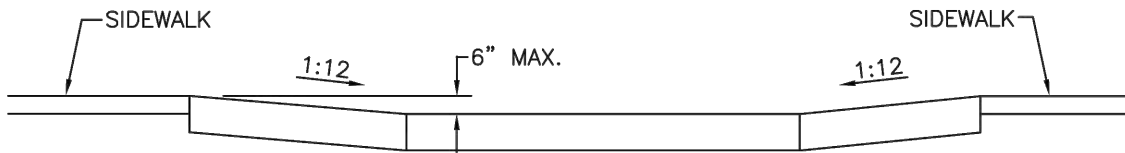

ELEVATION

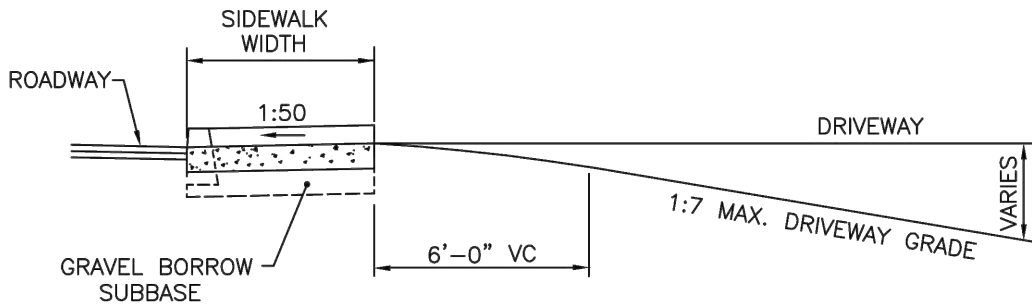

SECTION A-A

DRIVEWAY DEVELOPMENT FOR 6'-0" TRANSITION CURB

NOT TO SCALE

NOTES:

- 1. SHALL BE IN ACCORDANCE WITH SECTION 905 OF THE R.I. STANDARD SPECIFICATIONS.

SOURCE: PROVIDENCE DEPARTMENT OF TRANSPORTATION



CITY OF PROVIDENCE, RHODE ISLAND
 PROVIDENCE WATER SUPPLY BOARD
 ACCELERATED LEAD SERVICE LINE
 REPLACEMENT PROGRAM
 CONTRACT 1.4

Detail No. 19

MARCH 2024

GENERAL NOTES:

1. ANY DAMAGE TO EXISTING PAVEMENT, BRIDGES, CONDUIT, SIDEWALK, FENCES, ETC., CAUSED BY THE CONTRACTOR SHALL BE REPAIRED BY THE CONTRACTOR AT NO ADDITIONAL COST TO THE OWNER.
2. THE CONTRACTOR SHALL PLACE ALL EQUIPMENT AND MATERIAL AS FAR AWAY AS POSSIBLE FROM THE EDGE OF THE TRAVEL LANE SO AS NOT TO CAUSE A SAFETY HAZARD, IN ACCORDANCE WITH SECTION 106.06 OF THE R.I.D.O.T. STANDARD SPECIFICATION, LATEST EDITION.
3. IT IS THE CONTRACTOR'S RESPONSIBILITY TO ENSURE THAT THE EXISTING CONDITIONS ARE NOT OBLITERATED BEFORE CONTROL POINTS ARE LOCATED AND CONSTRUCTION LAYOUT IS ESTABLISHED. THE CONSTRUCTION LAYOUT SHALL BE PROVIDED IN SUFFICIENT DETAIL, THEREBY ENABLING HIM TO CONSTRUCT THE PROJECT IN CONFORMITY WITH THE PLANS AND SPECIFICATIONS. SURVEY WILL BE PROVIDED BY THE CONTRACTOR. THE RESIDENT ENGINEER WILL NOT AUTHORIZE CONSTRUCTION ACTIVITIES TO BEGIN UNTIL HE IS SATISFIED THAT ALL GROUND CONTROL HAS BEEN ESTABLISHED, TIED DOWN, AND DULY RECORDED IN STANDARD FIELD BOOKS.
4. ALL R.I. STD. 9.9.0 CONSTRUCTION ACCESS ROADS SHALL BE CONSTRUCTED PRIOR TO ANY ROADWAY ACCEPTING CONSTRUCTION TRAFFIC.
5. THE FREQUENCY AND APPLICATION RATES FOR THE DUST CONTROL ITEMS WILL BE AS DIRECTED BY THE ENGINEER.
6. ALL SIDEWALK AND DRIVEWAYS DESIGNATED FOR REPLACEMENT SHALL BE CUT AND MATCHED AT LOCATIONS SHOWN ON THE PLANS OR AS DIRECTED BY THE ENGINEER.
7. ASPHALT EMULSION TACK COAT SHALL BE PLACED PRIOR TO PAVEMENT PLACEMENT ON THE CONCRETE BASE OR COLD PLANED PAVEMENT, AND ON ANY NEW COURSE WHICH HAS BEEN OPEN TO TRAFFIC, OR ANY NEW COURSE WHICH HAS BEEN EXPOSED FOR MORE THAN 3 DAYS, AND/OR AS DIRECTED BY THE ENGINEER. IT SHALL ALSO BE APPLIED TO VERTICAL PAVEMENT FACES BETWEEN ADJOINING PAVEMENT SECTIONS. ALL APPLICATIONS ON BOTH HORIZONTAL AND VERTICAL SURFACES SHALL BE PAID FOR UNDER THE CONTRACT UNIT BID PRICE FOR CODE 403.0300 "ASPHALT EMULSION TACK COAT."
8. THE LIMITS OF CLEARING AND SURFACE DISTURBANCE MUST BE STRICTLY ADHERED TO IN ALL AREAS. IN ADDITION TO THOSE AREAS SPECIFICALLY DESIGNATED ON THE PLANS, THE CONTRACTOR WILL BE RESPONSIBLE FOR PROVIDING AND PLACING, AT HIS OWN EXPENSE, PLANTABLE SOIL AND SEED IN AREAS WHICH ARE OUTSIDE OF THE PROJECT'S AREAS OF DISTURBANCE AND WHICH ARE IMPACTED BY CONSTRUCTION OPERATIONS INCLUDING THOSE AREAS WHERE VEHICLES, EQUIPMENT AND MATERIALS ARE STORED WITH THE PERMISSION OF THE ENGINEER.
9. UNDER NO CIRCUMSTANCE WILL THE CONTRACTOR BE ALLOWED TO STOCKPILE REMOVED PAVEMENT MATERIALS WITHIN THE PROJECT LIMITS.
10. CLEANING AND SWEEPING OF PAVEMENT WILL INCLUDE REMOVAL OF ALL PAVEMENT DEBRIS PRIOR TO THE PLACEMENT OF EACH BITUMINOUS PAVEMENT LIFT. ALL CLEANING AND SWEEPING SHALL BE DONE TO THE SATISFACTION OF THE ENGINEER.
11. PRIOR TO INSTALLATION, ALL SIGNS, MOUNTINGS AND LOCATIONS SHALL BE APPROVED OR MODIFIED BY THE ENGINEER.
12. THE COORDINATE SYSTEM, IF SHOWN, IS THE RHODE ISLAND STATE PLANE COORDINATE SYSTEM.
13. PAVEMENT OPERATIONS FOR CURBED SECTIONS: IN AREAS WHERE CURBING IS SET TO FINISH LINE AND GRADE, THE CONTRACTOR WILL NOT BE REQUIRED TO UTILIZE THE SENSOR AND SKY-TYPE DEVICE FOR AUTOMATIC GRADE CONTROL, BUT WILL BE ALLOWED TO MANUALLY ADJUST THE BITUMINOUS PAVER FOR CONTROLLING GRADE.
14. THE CONTRACTOR SHALL BE RESPONSIBLE FOR MAINTAINING ALL ROADWAYS FREE OF DEBRIS RESULTING FROM THEIR CONSTRUCTION OPERATIONS. ALL DEBRIS SHALL BE REMOVED TO THE SATISFACTION OF THE ENGINEER AT NO ADDITIONAL COST TO THE STATE.
15. NO FUEL STORAGE, VEHICLE REFUELING, OR EQUIPMENT STORAGE SHALL TAKE PLACE IN DESIGNATED WETLANDS, NOR WITHIN 100' OF ANY WATER BODY. THIS REQUIREMENT SHALL NOT SUPERSEDE ANY FEDERAL, STATE OR LOCAL LAW, ORDINANCE, RULE OR REGULATION THAT APPLIES TO THE SAME, UNLESS THIS REQUIREMENT IS MORE STRINGENT THAN SAID LAW, ORDINANCE, RULE OR REGULATION.
16. THE CONTRACTOR SHALL BE RESPONSIBLE TO ENSURE THAT AT THE END OF FINAL PAVING OPERATIONS, FLOW TO EXISTING DRAINAGE STRUCTURES HAS BEEN REESTABLISHED AND THAT NO ISOLATED DEPRESSIONS REMAIN. THERE SHALL BE NO SEPARATE PAYMENT FOR THIS PROVISION; IT SHALL BE CONSIDERED INCIDENTAL TO PAVING AND COLD PLANING OPERATIONS.
17. ALL EMBANKMENTS SHALL BE PLACED IN HORIZONTAL LAYERS NOT EXCEEDING 12" (AFTER COMPACTION) AND SHALL BE COMPACTED AS SPECIFIED BEFORE THE NEXT LAYER IS PLACED. ALSO, EMBANKMENT CONSTRUCTION SHALL CONFORM TO SECTION 202.03.2 OF THE R.I.D.O.T. STANDARD SPECIFICATIONS, LATEST EDITION.
18. IF THIS PROJECT IS ON A HURRICANE EVACUATION AND DIVERSIONARY ROUTE, AS DESIGNATED ON THE COVERSHEET, THE CONTRACTOR IS ADVISED THAT UPON 12 (TWELVE) HOURS NOTICE THE ROADWAY SHALL BE OPEN TO EVACUEES AND EMERGENCY PERSONNEL. ANY EXTRA WORK NECESSARY TO COMPLY WITH THIS REQUIREMENT WILL BE REIMBURSED UNDER FORCE ACCOUNT PROCEDURES.
19. THE CONTRACTOR SHALL READ, BECOME FAMILIAR WITH, AND ADHERE TO ALL OF THE PROVISIONS, CONDITIONS, AND STIPULATIONS STATED IN THE ENVIRONMENTAL APPROVALS ISSUED FOR THE PROJECT FROM THE DEPARTMENT OF ENVIRONMENTAL MANAGEMENT (RIDEM). AND/OR THE ARMY CORPS OF ENGINEERS (ACOE). AND/OR THE COASTAL RESOURCES MANAGEMENT COUNCIL (CRMC). COPIES OF EACH OF THESE PERMITS ARE INCLUDED IN THE CS PAGES OF THE CONTRACT DOCUMENTS. ALL COSTS ASSOCIATED WITH THESE CONDITIONS SHALL BE CONSIDERED INCIDENTAL TO THE CONSTRUCTION AND INCLUDED WITH THE COST FOR THE ASSOCIATED BID ITEM(S).
20. FOR ALL PROJECTS INVOLVING KNOWN SITE REMEDIATION ISSUES, THE CONTRACTOR SHALL READ, BECOME FAMILIAR WITH, AND ADHERE TO ALL OF THE CONSTRUCTION RELATED PROVISIONS, CONDITIONS, AND STIPULATIONS OF ANY REMEDIAL PLANS DEVELOPED FOR THE PROJECT. COPIES OF THESE DOCUMENTS ARE INCLUDED IN THE CS PAGES OF THE CONTRACT DOCUMENTS. ALL COSTS ASSOCIATED WITH COMPLIANCE WITH THESE DOCUMENTS SHALL BE CONSIDERED INCIDENTAL TO THE CONSTRUCTION AND INCLUDED WITH THE COST FOR THE ASSOCIATED BID ITEM(S).
21. NO UNPROTECTED CONSTRUCTED FEATURE MAY PROJECT MORE THAN 4 INCHES ABOVE THE FINISHED GRADE OF A TRAVERSABLE SLOPE IN A CLEAR ZONE, e.g. HEADWALL, DRAINAGE INLET, ETC.
22. THE REMAINING SECTION OR STUB OF A BREAKAWAY BASE MAY NOT PROJECT MORE THAN 4 INCHES ABOVE THE FINISHED GRADE OF A TRAVERSABLE SLOPE IN A CLEAR ZONE, e.g. SIGN POSTS, LIGHT POLES, FIRE HYDRANTS, ETC.

DRAINAGE AND EROSION CONTROL NOTES:

1. FOR ALL PROJECTS WITH AT LEAST ONE(1) ACRE OF SOIL DISTURBANCE. R.I.D.O.T. IS REQUIRED TO DEVELOP AND ENFORCE A SITE SPECIFIC STORM WATER POLLUTION PREVENTION PLAN (SWPPP) IN ORDER TO REMAIN IN COMPLIANCE WITH THE RIPDES GENERAL PERMIT FOR STORMWATER DISCHARGES ASSOCIATED WITH CONSTRUCTION ACTIVITIES. THE CONTRACTOR SHALL READ, BECOME FAMILIAR WITH, AND ADHERE TO ALL OF THE PROVISIONS, CONDITIONS, AND STIPULATIONS OF THE GENERAL PERMIT AND THE SITE SPECIFIC SWPPP FOR THIS PROJECT. COPIES OF THESE DOCUMENTS ARE INCLUDED IN THE CS PAGES OF THE CONTRACT DOCUMENTS. ALL COSTS ASSOCIATED WITH ADHERENCE TO THE SWPPP SHALL BE CONSIDERED INCIDENTAL TO THE CONSTRUCTION AND INCLUDED WITH THE COST FOR THE ASSOCIATED BID ITEM(S).
2. NO UNDISTURBED AREAS SHALL BE CLEARED OF EXISTING VEGETATION AFTER OCTOBER 15 OF ANY CALENDAR YEAR OR DURING ANY PERIOD OF FULL OR LIMITED WINTER SHUTDOWN. ALL DISTURBED SOILS EXPOSED PRIOR TO OCTOBER 15 OF ANY CALENDAR YEAR SHALL BE SEEDED OR PROTECTED BY THAT DATE. ANY SUCH AREAS THAT DO NOT HAVE ADEQUATE VEGETATIVE STABILIZATION, AS DETERMINED BY THE RESIDENT ENGINEER OR ENVIRONMENTAL INSPECTOR, BY NOVEMBER 15 OF ANY CALENDAR YEAR, MUST BE STABILIZED THROUGH THE USE OF EROSION CONTROL MATTING OR HAY MULCH, IN ACCORDANCE WITH SPECIFICATIONS CONTAINED WITHIN THE R.I. SOIL EROSION AND SEDIMENT CONTROL HANDBOOK. IF WORK CONTINUES WITHIN ANY OF THESE AREAS DURING THE PERIOD FROM OCTOBER 15 THROUGH APRIL 15, CARE MUST BE TAKEN TO ENSURE THAT ONLY THE AREA REQUIRED FOR THAT DAY'S WORK IS EXPOSED, AND ALL ERODIBLE SOIL MUST BE RESTABILIZED WITHIN 5 WORKING DAYS. ANY WORK TO CORRECT PROBLEMS RESULTING FROM FAILURE TO COMPLY WITH THIS PROVISION SHALL BE THE RESPONSIBILITY OF THE CONTRACTOR. THERE WILL BE NO SEPARATE PAYMENT FOR THIS PROVISION, IT SHALL BE CONSIDERED INCIDENTAL TO CONSTRUCTION OPERATIONS. STABILIZATION OF ONE FORM OR ANOTHER AS DESCRIBED ABOVE SHALL BE ACHIEVED WITHIN 2 WEEKS OF FINAL GRADING.
3. STOCKPILES OF MATERIAL SHALL NOT BE LOCATED WITHIN REGULATED WETLANDS OR BUFFER ZONE AREAS. THEY SHALL HAVE SIDE SLOPES NO GREATER THAN 30% AND STOCKPILES OF ERODABLE MATERIAL SHALL ALSO BE SEEDED AND RINGED WITH R.I. STD. 9.1.0 TO STABILIZE.
4. IF THE PLANS INCLUDE SPECIFIC AREAS FOR PLACEMENT OF CONSTRUCTION DEWATERING BASINS AND/OR EQUIPMENT AND MATERIALS STORAGE AND STOCKPILING, AND IF THE CONTRACTOR ELECTS TO UTILIZE ANY OTHER AREAS FOR THESE PURPOSES, THIS SHALL BE APPROVED BY THE ENGINEER ONLY AFTER OBTAINING ANY NECESSARY PERMITS AND/OR PERMIT MODIFICATIONS FROM THE APPROPRIATE REGULATORY AUTHORITY(IES). ANY PERMITTING REQUIREMENTS SHALL BE THE RESPONSIBILITY OF THE CONTRACTOR AND SHALL BE ACCOMPLISHED AT NO COST TO THE STATE. THE ENGINEER WILL COORDINATE SUBMISSION OF ANY REQUIRED PERMIT APPLICATION MATERIALS WITH THE R.I.D.O.T. OFFICE OF ENVIRONMENTAL PROGRAMS.
5. JUTE MESH SHALL BE USED TO STABILIZE PLANTABLE SOIL AND/OR LOAM IN ALL DITCHES, ON ALL SLOPES ADJACENT TO WETLANDS AND WETLAND PERIMETERS, AND ON ALL SLOPES WITHIN WATER QUALITY BASINS. JUTE MESH IN DITCHES SHALL EXTEND TO AN ELEVATION 2 FEET ABOVE THE BOTTOM OF THE DITCH.
6. SEEDING ON ALL SLOPES 3 TO 1 OR STEEPER SHALL CONSIST OF THE FOLLOWING APPLICATIONS UNLESS CHANGED IN THE CONTRACT.
 - a. SEEDING TYPE I.
 - b. ADHESIVE MULCH STABILIZER
7. UNVEGETATED SLOPES SHALL NOT BE UNATTENDED OR EXPOSED FOR PERIODS IN EXCESS OF 2 WEEKS OR THROUGH THE INACTIVE WINTER SEASON.
8. PRIOR TO DRAINAGE AND UTILITY CONSTRUCTION, THE CONTRACTOR IS RESPONSIBLE FOR VERIFYING THE LOCATION (HORIZONTAL AND VERTICAL) OF ALL EXISTING PIPES AND/OR STRUCTURES WHICH ARE TO BE CONNECTED. ANY VARIATION FOUND FROM THE PLANS MUST BE BROUGHT TO THE ENGINEER'S ATTENTION PRIOR TO DRAINAGE AND UTILITY CONSTRUCTION. WORK CAN COMMENCE ONLY UPON THE ENGINEER'S AUTHORIZATION.
9. ALL DRAINAGE AND UTILITY STRUCTURES WITHIN THE PAVED ROADWAY SHALL BE ADJUSTED TO GRADE WITH THE SURROUNDING PAVEMENT PRIOR TO THE WINTER SHUTDOWN.
10. DURING CONSTRUCTION, THE CONTRACTOR SHALL BE RESPONSIBLE FOR MAINTAINING DRAINAGE AND RUNOFF FLOW DURING STORMS AND PERIODS OF RAINFALL THROUGHOUT THE WORK AREA.
11. PRIOR TO COMMENCING CONSTRUCTION ACTIVITIES, EROSION AND SEDIMENTATION CONTROLS SHALL BE INSTALLED AT THOSE AREAS INDICATED ON THE PLANS. CLEARING MAY OCCUR PRIOR TO INSTALLATION OF SUCH CONTROLS, HOWEVER NO GRUBBING, GRADING, FILLING, OR OTHER SOIL DISTURBANCE SHALL OCCUR PRIOR TO INSTALLATION. THE LIMITS OF CLEARING AND SURFACE DISTURBANCE MUST BE STRICTLY ADHERED TO IN ALL AREAS.
12. THE CONTRACTOR MUST REPAIR AND/OR RESEED ANY AREAS THAT DO NOT DEVELOP WITHIN THE PERIOD OF ONE YEAR AND HE SHALL DO SO AT NO ADDITIONAL EXPENSE TO THE STATE.
13. THE NORMAL ACCEPTABLE SEASONAL SEEDING DATES ARE SPECIFIED IN SUBSECTION L.02.03 OF THE R.I.D.O.T. STANDARD SPECIFICATIONS, LATEST EDITION.
14. ADDITIONAL EROSION CONTROLS, SHALL BE INSTALLED AS DIRECTED BY THE RESIDENT ENGINEER. THESE ADDITIONAL ITEMS WILL BE PAID AT THE UNIT PRICE FOR THAT BID ITEM.

XREFs: [] Images: []
Last saved by: CABRERAJG Time: 6/29/2023 9:17:41 AM
C:\pw_pl1\cabrerajg\3271389\DETAIL 20b.dwg



LANDSCAPE NOTES:

1. ALL PLANT MATERIAL MUST BE TAGGED AT THE NURSERY (A RECOGNIZED GROWER OF PLANT MATERIAL) IN ACCORDANCE WITH THE R.I.D.O.T. STANDARD SPECIFICATIONS, LATEST EDITION. ALL PLANT MATERIAL MUST BE NURSERY GROWN; NO PLANTATION GROWN PLANT MATERIAL WILL BE ACCEPTED.
2. ALL PLANT SUBSTITUTIONS AND/OR CHANGES IN PLANT LOCATION MUST BE APPROVED IN ACCORDANCE WITH THE R.I.D.O.T. STANDARD SPECIFICATIONS, LATEST EDITION.
3. ALL PLANT MATERIAL IS TO BE FIELD LOCATED BY A REPRESENTATIVE FROM THE R.I.D.O.T. LANDSCAPE ARCHITECTURE UNIT.
4. A R.I.D.O.T. LANDSCAPE REPRESENTATIVE MUST BE ON SITE TO APPROVE ALL TRIMMING AND CLEARING NECESSARY TO COMPLETE THE WORK AS SHOWN ON THE PLANS.
5. ANY TOPSOIL USED AS PLANTABLE SOIL SHALL HAVE A SANDY LOAM TEXTURE RELATIVELY FREE OF SUBSOIL MATERIAL, STONES, ROOTS, LUMPS OF SOIL, TREE LIMBS, TRASH OR CONSTRUCTION DEBRIS, AND SHALL CONFORM TO SECTION M.18 OF THE R.I.D.O.T. STANDARD SPECIFICATIONS, LATEST EDITION.
6. ALL TREES AND SHRUBS SHALL BE MULCHED WITH PINE BARK MULCH IN ACCORDANCE WITH THE R.I.D.O.T. STANDARD SPECIFICATIONS, LATEST EDITION.
7. ALL TREES AND/OR SHRUBS THAT ARE PLANTED AS A BED SHALL BE MULCHED AS A BED.
8. PROVIDE A MINIMUM 6'-8" BRANCHING STANDARD ON ALL TREES INSTALLED ADJACENT TO SIDEWALKS AND/OR PEDESTRIAN ACCESS AREAS.

UTILITY NOTES:

1. THE CONTRACTOR SHALL VERIFY THE LOCATIONS OF ALL EXISTING DRAINAGE AND UTILITIES BOTH UNDERGROUND AND OVERHEAD BEFORE EXCAVATION BEGINS IN ACCORDANCE WITH CHAPTER 39-1.2 OF THE R.I. GENERAL LAWS ENTITLED "EXCAVATION NEAR UNDERGROUND UTILITY FACILITIES", WITH AMENDMENTS EFFECTIVE AS OF NOVEMBER 1, 2009 AND, WHEN NECESSARY, BY CONTACTING THE INDIVIDUAL UTILITY COMPANIES. EXCAVATION SHALL BE IN ACCORDANCE WITH ALL STATUTES, ORDINANCES, RULES AND REGULATIONS OF ANY APPLICABLE CITY, TOWN, STATE OR FEDERAL AGENCY. THE CONTRACTOR SHOULD UNDERSTAND THAT NOT ALL UTILITIES SUBSCRIBE TO THE DIG SAFE PROGRAM. IT IS THE CONTRACTOR'S RESPONSIBILITY TO NOTIFY ALL UTILITY COMPANIES AND ENSURE THAT ALL UTILITIES HAVE BEEN MARKED PRIOR TO COMMENCING THEIR WORK. ANY DAMAGE TO EXISTING UTILITIES MARKED IN THE FIELD, OR AS A RESULT OF FAILING TO CONTACT THE APPROPRIATE UTILITY COMPANY, SHALL BE REPAIRED OR REPLACED AT NO ADDITIONAL COST TO THE STATE.
2. ALL EXISTING UTILITIES TO BE ABANDONED SHALL BE CAPPED.
3. EXISTING WATER SERVICES SHALL BE RECONNECTED TO THE NEW WATER MAINS.
4. UTILITY SERVICE CONNECTIONS SHALL BE MAINTAINED TO ALL EXISTING FACILITIES TO REMAIN.
5. FIRE HYDRANTS SHALL NOT BE REMOVED FROM SERVICE WITHOUT WRITTEN AUTHORIZATION FROM THE FIRE DEPARTMENT OR THE WATER AUTHORITY.
6. ALL NEW WATER LINES SHALL BE DISINFECTED TO THE SATISFACTION OF THE WATER AUTHORITY IN ACCORDANCE WITH THE SPECIFICATIONS.
7. ALL UTILITY POLE RELATED WORK SHALL BE BY OTHERS.

XREFs: [] Images: []
Last saved by: CABRERAJG Time: 6/29/2023 9:17:27 AM
C:\pw_pl1\cabrerajg\3271389\DETAIL 20c.dwg



XREFs: [] Images: []

Last saved by: CABRERAJG Time: 6/28/2023 11:05:19 PM

C:\pw_pl1\cabrerajg\3271389\DETAIL 21.dwg

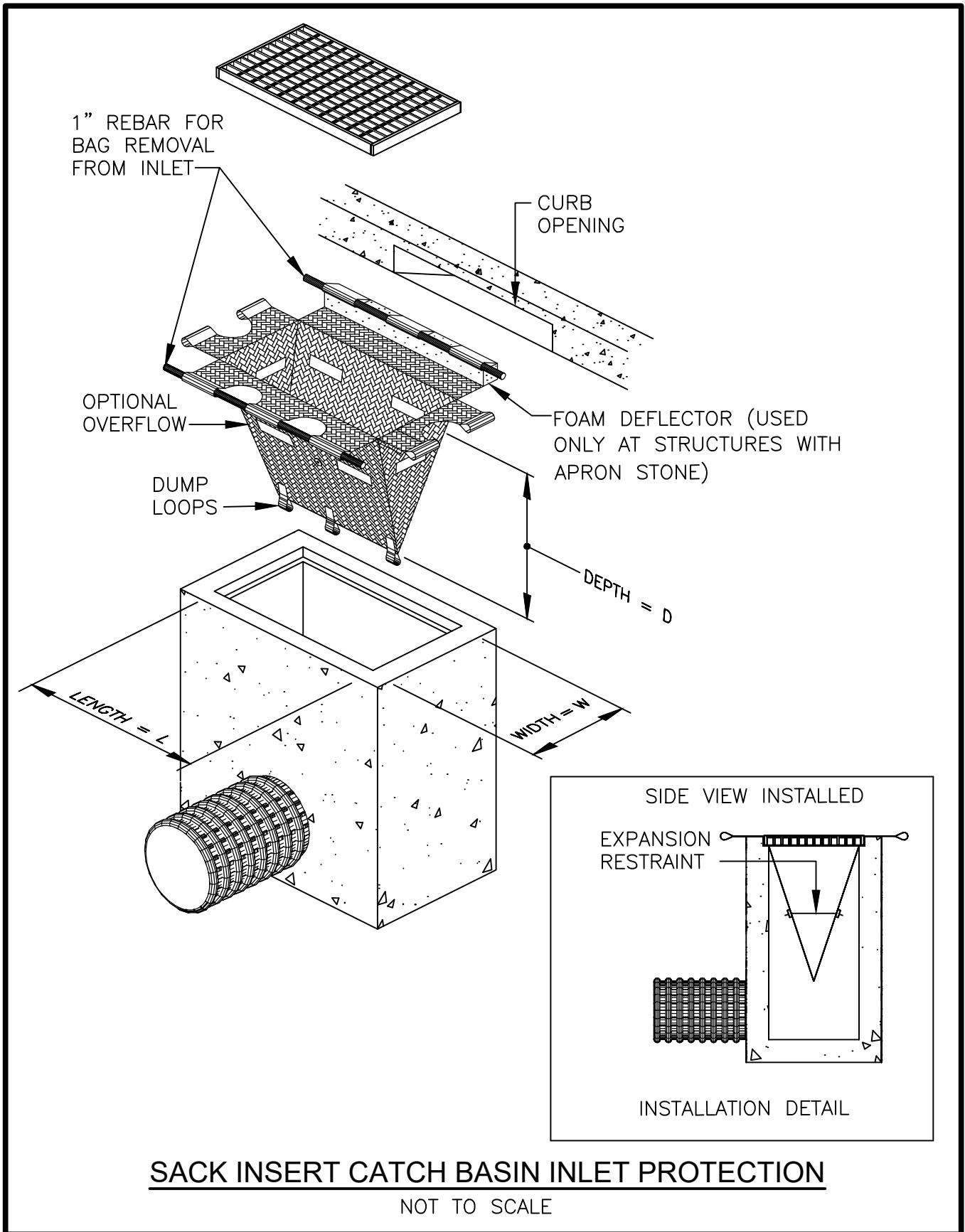

XREFs: [] Images: []
Last saved by: CABRERAJG Time: 6/28/2023 11:05:25 PM
C:\pw_pl1\cabrerajg\3271389\DETAIL 22.dwg

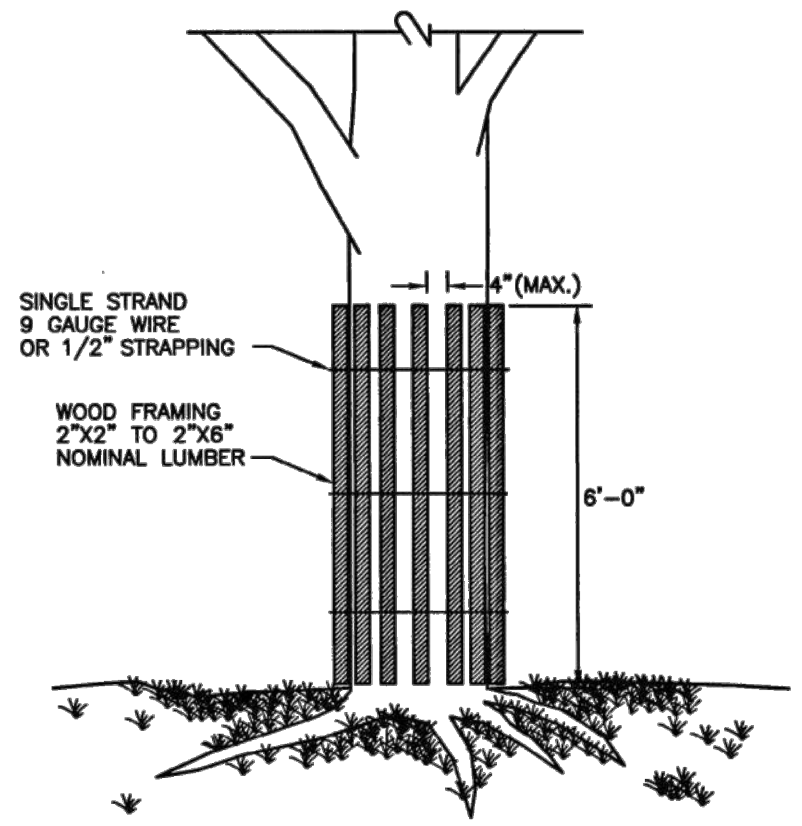

TREE PROTECTION DEVICE
NOT TO SCALE

NOTE:
SHALL BE IN ACCORDANCE WITH SECTION L.11 OF THE STANDARD SPECIFICATIONS.

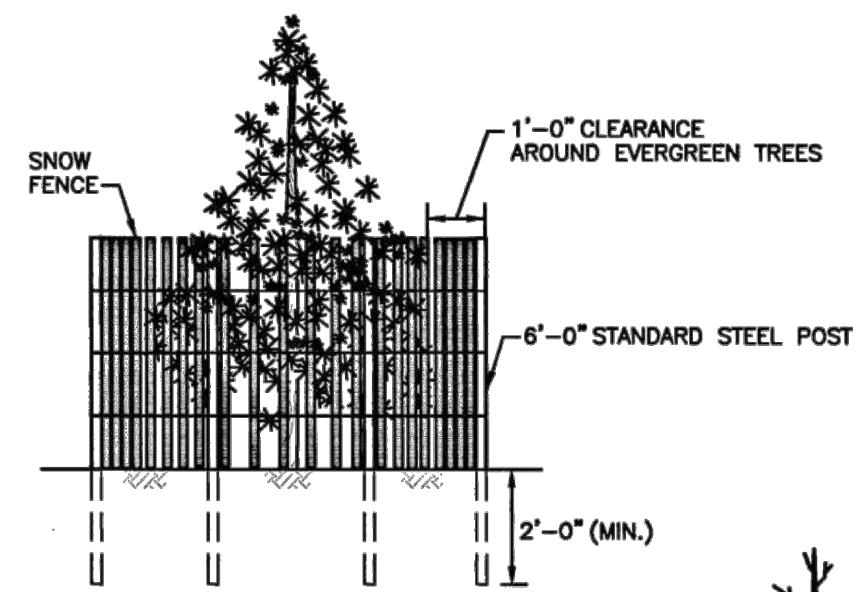

EVERGREEN TREE

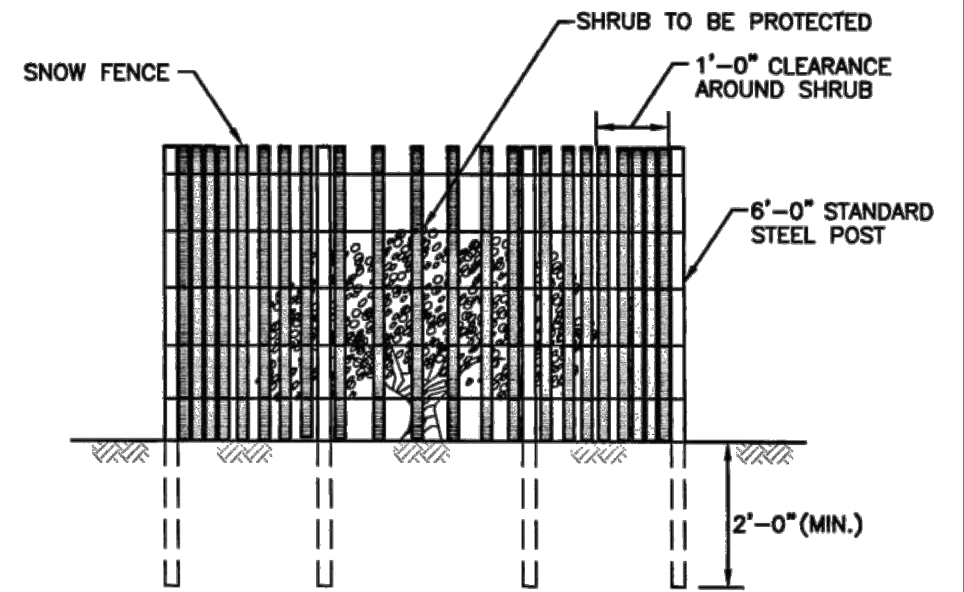

SHRUB PROTECTION DEVICE
NOT TO SCALE

NOTE:
SHALL BE IN ACCORDANCE WITH SECTION L.11 OF THE R.I. STANDARD SPECIFICATIONS.

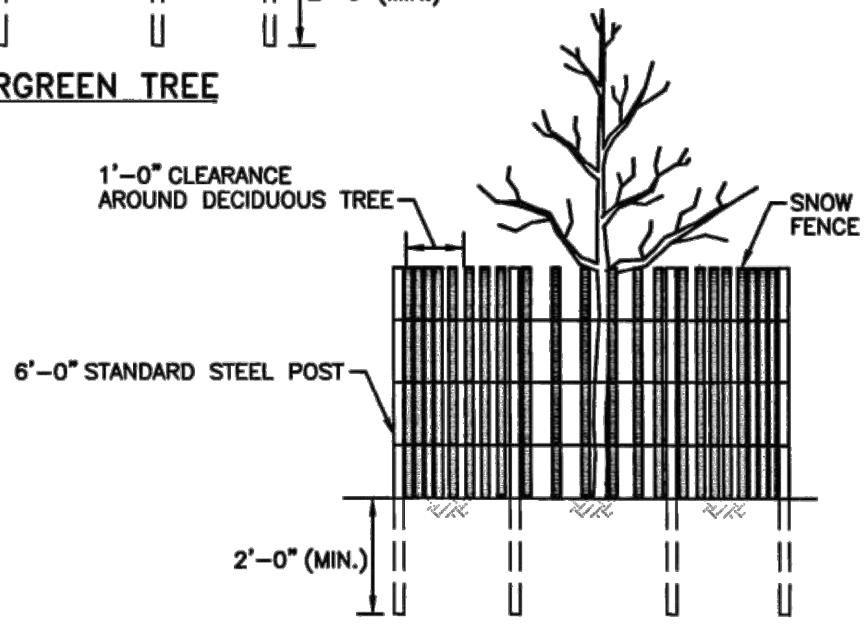

DECIDUOUS TREE

NOTE:
SHALL BE IN ACCORDANCE WITH SECTION L.11 OF THE R.I. STANDARD SPECIFICATIONS.

SOURCE: RHODE ISLAND DEPARTMENT OF TRANSPORTATION



CITY OF PROVIDENCE, RHODE ISLAND
PROVIDENCE WATER SUPPLY BOARD
ACCELERATED LEAD SERVICE LINE REPLACEMENT PROGRAM
CONTRACT 1.4

Detail No. 22
MARCH 2024

1. ALL TEMPORARY TRAFFIC CONTROL SET-UPS AND DEVICES AND THEIR INSTALLATION, MAINTENANCE, AND REMOVAL SHALL CONFORM TO THE LATEST EDITION OF THE "MANUAL ON UNIFORM TRAFFIC CONTROL DEVICES" (MUTCD) WITH ALL REVISIONS, AND THE LATEST EDITION OF THE "RIDOT STANDARD SPECIFICATIONS FOR ROAD AND BRIDGE CONSTRUCTION" WITH ALL REVISIONS.
2. ALL TEMPORARY TRAFFIC CONTROL DEVICES SHALL BE IN PLACE PRIOR TO THE START OF WORK.

ALL TEMPORARY TRAFFIC CONTROL DEVICES SHALL BE REMOVED AS SOON AS PRACTICAL WHEN THEY ARE NO LONGER NEEDED. WHEN WORK IS SUSPENDED FOR SHORT PERIODS OF TIME, TEMPORARY TRAFFIC CONTROL DEVICES THAT ARE NO LONGER APPROPRIATE SHALL BE REMOVED OR COVERED.
4. DISTANCES ARE A GUIDE AND MAY BE ADJUSTED IN THE FIELD BY THE ENGINEER.
5. THE MAXIMUM ALLOWABLE LENGTH OF THE SHIFTED TANGENT SECTION FOR THE TEMPORARY TRAFFIC CONTROL SET-UP SHOWN IS 600 FEET.

6. MAXIMUM SPACING OF CHANNELIZATION DEVICES IN A TAPER IS EQUAL IN FEET TO THE SPEED LIMIT IN MPH. MAXIMUM SPACING OF CHANNELIZATION DEVICES IN A TANGENT SECTION IS EQUAL IN FEET TO TWO TIMES THE SPEED LIMIT IN MPH. SHORTER SPACINGS SHOULD BE USED FOR CHANNELIZATION DEVICES INSTALLED BETWEEN TRAFFIC TRAVELING IN OPPOSITE DIRECTIONS WHERE ADDITIONAL EMPHASIS IS NEEDED TO CLEARLY DEFINE THE DESIRED TRAVEL PATHS.
7. MINIMUM LANE WIDTH IS TO BE 11 FEET UNLESS OTHERWISE SHOWN. MINIMUM LANE WIDTH TO BE MEASURED FROM THE EDGE OF CHANNELIZATION DEVICES.
8. THE SIZES OF ALL DIAMOND SHAPED ADVANCE WARNING SIGNS SHALL BE 36" X 36".
9. WHERE A SIDE STREET OR RAMP INTERSECTS THE WORK ZONE, ADDITIONAL TEMPORARY TRAFFIC CONTROL DEVICES SHALL BE INSTALLED IN ACCORDANCE WITH PART 6 OF THE MUTCD.

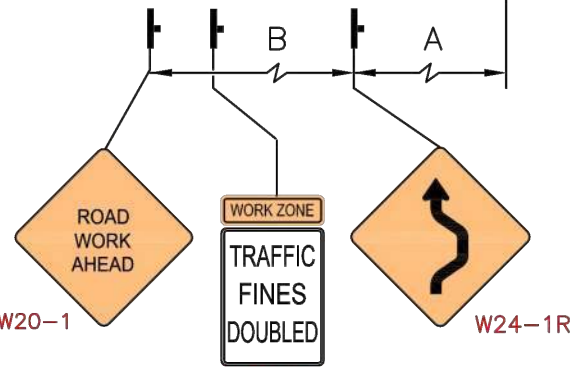
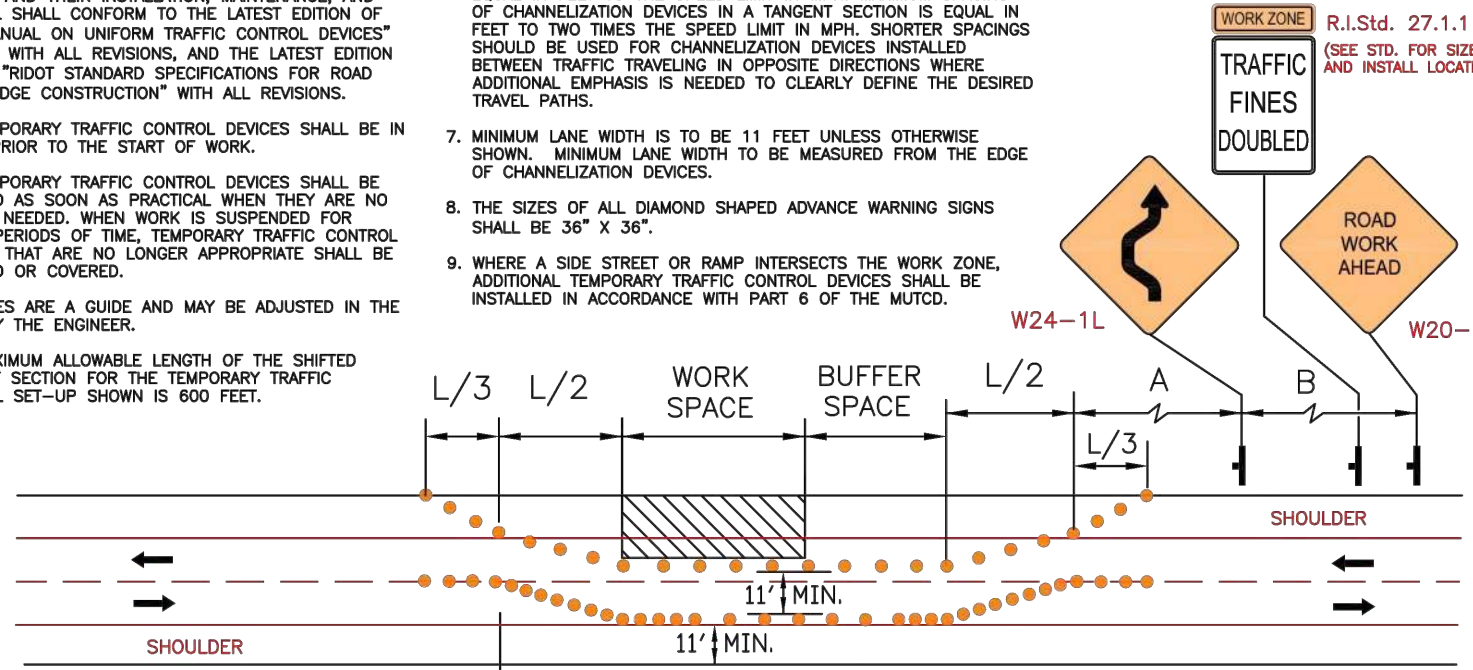

R.I.Std. 27.1.1

TAPER AND BUFFER LENGTHS

Speed Limit	Taper Length* (L) Feet	Buffer Space* (Feet)
25 MPH	125	55
30 MPH	180	85
35 MPH	245	120
40 MPH	320	170
45 MPH	540	220
50 MPH	600	280

* Required
** Suggested

MINIMUM ADVANCE WARNING SIGN SPACING

Posted Speed Limit & Location	Distance Between Signs (Feet)		
	A	B	C
30 MPH OR LESS in URBAN OR RURAL AREA	100	100	100
35 MPH OR GREATER in URBAN AREA	350	350	350
35 MPH OR GREATER in RURAL AREA	500	500	500

TYPICAL LANE SHIFT ON TWO-LANE ROADWAY

SOURCE: RHODE ISLAND DEPARTMENT OF TRANSPORTATION



CITY OF PROVIDENCE, RHODE ISLAND
 PROVIDENCE WATER SUPPLY BOARD
 ACCELERATED LEAD SERVICE LINE REPLACEMENT PROGRAM
 CONTRACT 1.4

Detail No. 23

MARCH 2024

NOTES:

1. ALL TEMPORARY TRAFFIC CONTROL SET-UPS AND DEVICES AND THEIR INSTALLATION, MAINTENANCE, AND REMOVAL SHALL CONFORM TO THE LATEST EDITION OF THE "MANUAL ON UNIFORM TRAFFIC CONTROL DEVICES" (MUTCD) WITH ALL REVISIONS, AND THE LATEST EDITION OF THE "RIDOT STANDARD SPECIFICATIONS FOR ROAD AND BRIDGE CONSTRUCTION" WITH ALL REVISIONS.
2. ALL TEMPORARY TRAFFIC CONTROL DEVICES SHALL BE IN PLACE PRIOR TO THE START OF WORK.
3. ALL TEMPORARY TRAFFIC CONTROL DEVICES SHALL BE REMOVED AS SOON AS PRACTICAL WHEN THEY ARE NO LONGER NEEDED. WHEN WORK IS SUSPENDED FOR SHORT PERIODS OF TIME, TEMPORARY TRAFFIC CONTROL DEVICES THAT ARE NO LONGER APPROPRIATE SHALL BE REMOVED OR COVERED.
4. DISTANCES ARE A GUIDE AND MAY BE ADJUSTED IN THE FIELD BY THE ENGINEER.
5. THE BUFFER SPACES SHOULD BE EXTENDED IF NECESSARY SO THAT THE 100' MAX. TWO-WAY TRAFFIC TAPERS ARE PLACED BEFORE HORIZONTAL (OR CREST VERTICAL) CURVES TO PROVIDE ADEQUATE SIGHT DISTANCE FOR THE FLAGGERS AND QUEUES OF STOPPED VEHICLES.
6. MAXIMUM SPACING OF CHANNELIZATION DEVICES IN THE 100' MAX. TWO-WAY TRAFFIC TAPERS IS 25 FEET. MAXIMUM SPACING OF CHANNELIZATION DEVICES IN A TANGENT SECTION IS EQUAL IN FEET TO TWO TIMES THE SPEED LIMIT IN MPH.
7. MINIMUM LANE WIDTH IS TO BE 10 FEET UNLESS OTHERWISE SHOWN. MINIMUM LANE WIDTH TO BE MEASURED FROM THE EDGE OF CHANNELIZATION DEVICES OR TEMPORARY BARRIER.
8. THE SIZES OF ALL DIAMOND SHAPED ADVANCE WARNING SIGNS SHALL BE 36" X 36".
9. WHERE A SIDE STREET OR RAMP INTERSECTS THE WORK ZONE, ADDITIONAL TEMPORARY TRAFFIC CONTROL DEVICES SHALL BE INSTALLED IN ACCORDANCE WITH PART 6 OF THE MUTCD.

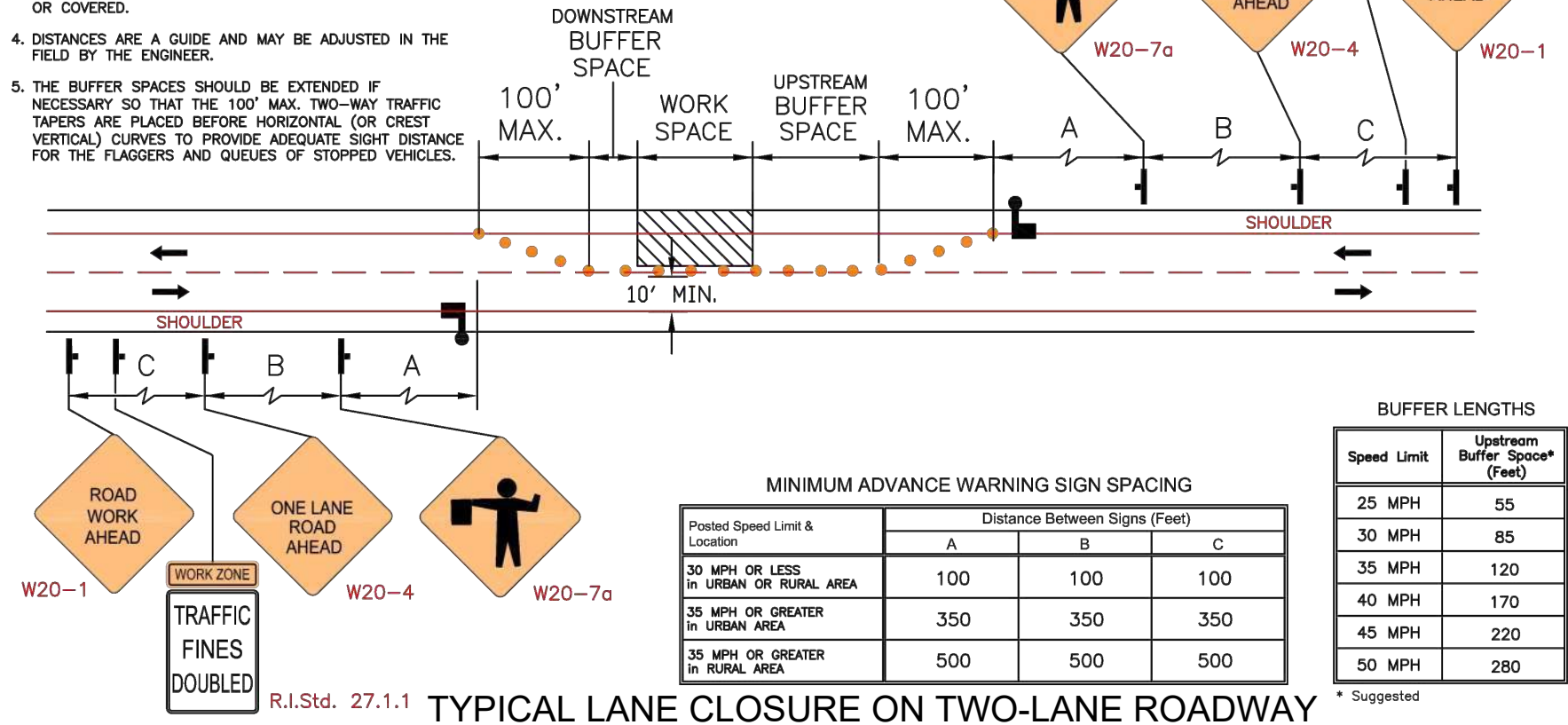

SOURCE: RHODE ISLAND DEPARTMENT OF TRANSPORTATION



CITY OF PROVIDENCE, RHODE ISLAND
 PROVIDENCE WATER SUPPLY BOARD
 ACCELERATED LEAD SERVICE LINE REPLACEMENT PROGRAM
 CONTRACT 1.4

Detail No. 24

MARCH 2024

NOTES:

1. ALL TEMPORARY TRAFFIC CONTROL SET-UPS AND DEVICES AND THEIR INSTALLATION, MAINTENANCE, AND REMOVAL SHALL CONFORM TO THE LATEST EDITION OF THE "MANUAL ON UNIFORM TRAFFIC CONTROL DEVICES" (MUTCD) WITH ALL REVISIONS, AND THE LATEST EDITION OF THE "RIDOT STANDARD SPECIFICATIONS FOR ROAD AND BRIDGE CONSTRUCTION" WITH ALL REVISIONS.
2. ALL TEMPORARY TRAFFIC CONTROL DEVICES SHALL BE IN PLACE PRIOR TO THE START OF WORK.
3. ALL TEMPORARY TRAFFIC CONTROL DEVICES SHALL BE REMOVED AS SOON AS PRACTICAL WHEN THEY ARE NO LONGER NEEDED. WHEN WORK IS SUSPENDED FOR SHORT PERIODS OF TIME, TEMPORARY TRAFFIC CONTROL DEVICES THAT ARE NO LONGER APPROPRIATE SHALL BE REMOVED OR COVERED.
4. DISTANCES ARE A GUIDE AND MAY BE ADJUSTED IN THE FIELD BY THE ENGINEER.
5. THE BUFFER SPACES SHOULD BE EXTENDED IF NECESSARY SO THAT THE 100' MAX. TWO-WAY TRAFFIC TAPERS ARE PLACED BEFORE HORIZONTAL (OR CREST VERTICAL) CURVES TO PROVIDE ADEQUATE SIGHT DISTANCE FOR THE FLAGGERS AND QUEUES OF STOPPED VEHICLES.
6. MAXIMUM SPACING OF CHANNELIZATION DEVICES IN THE 100' MAX. TWO-WAY TRAFFIC TAPERS IS 25 FEET. MAXIMUM SPACING OF CHANNELIZATION DEVICES IN A TANGENT SECTION IS EQUAL IN FEET TO TWO TIMES THE SPEED LIMIT IN MPH.
7. MINIMUM LANE WIDTH IS TO BE 10 FEET UNLESS OTHERWISE SHOWN. MINIMUM LANE WIDTH TO BE MEASURED FROM THE EDGE OF CHANNELIZATION DEVICES OR TEMPORARY BARRIER.
8. THE SIZES OF ALL DIAMOND SHAPED ADVANCE WARNING SIGNS SHALL BE 36" X 36".
9. WHERE A SIDE STREET OR RAMP INTERSECTS THE WORK ZONE, ADDITIONAL TEMPORARY TRAFFIC CONTROL DEVICES SHALL BE INSTALLED IN ACCORDANCE WITH PART 6 OF THE MUTCD.

R.I.Std. 27.1.1
(SEE STD. FOR SIZES AND INSTALL LOCATION)

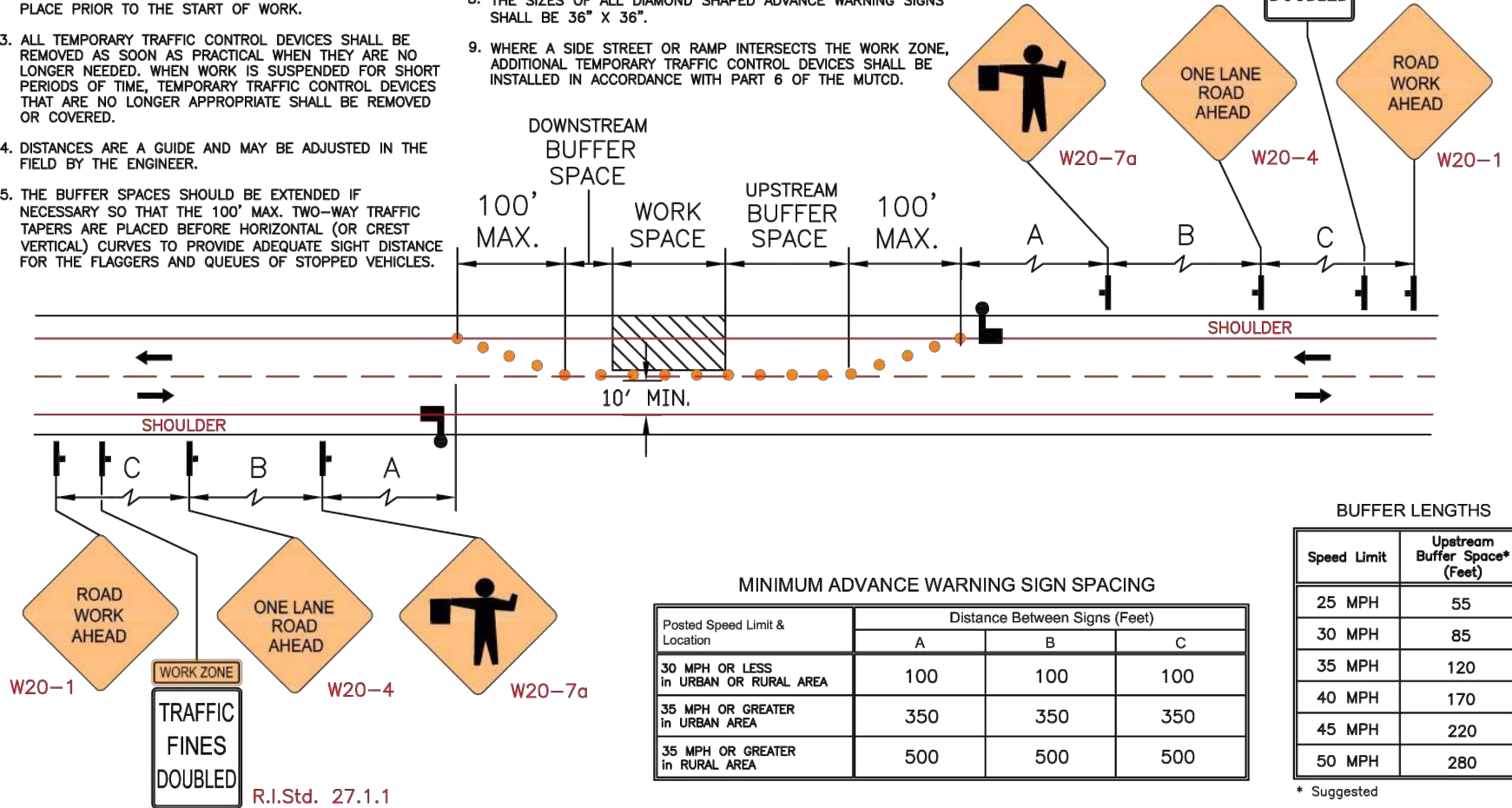

TYPICAL SHOULDER CLOSURE ON TWO-LANE ROADWAY

SOURCE: RHODE ISLAND DEPARTMENT OF TRANSPORTATION



CITY OF PROVIDENCE, RHODE ISLAND
 PROVIDENCE WATER SUPPLY BOARD
 ACCELERATED LEAD SERVICE LINE REPLACEMENT PROGRAM
 CONTRACT 1.4

Detail No. 25

MARCH 2024

Appendix C

Locations that Require Final Paving

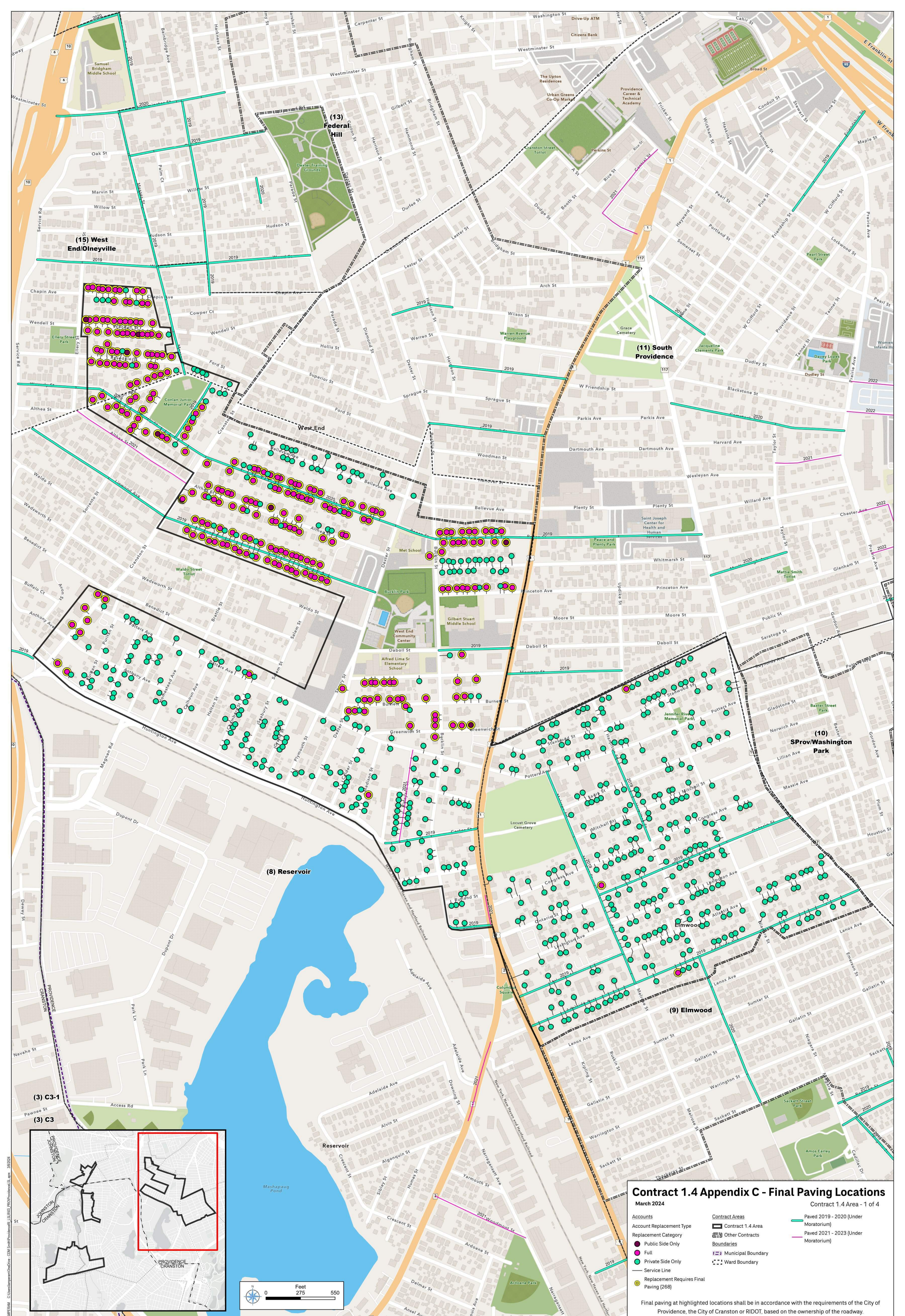

Contract 1.4 Appendix C - Final Paving Locations

March 2024

Contract 1.4 Area - 1 of 4

Accounts	Contract Areas	Paved 2019 - 2020 (Under Moratorium)
Account Replacement Type	Contract 1.4 Area	Paved 2021 - 2023 (Under Moratorium)
Replacement Category	Other Contracts	
Public Side Only	Boundaries	
Private Side Only	Full	
Replacement Requires Final Paving (268)	Municipal Boundary	
	Ward Boundary	
	Service Line	

Final paving at highlighted locations shall be in accordance with the requirements of the City of Providence, the City of Cranston or RIDOT, based on the ownership of the roadway.

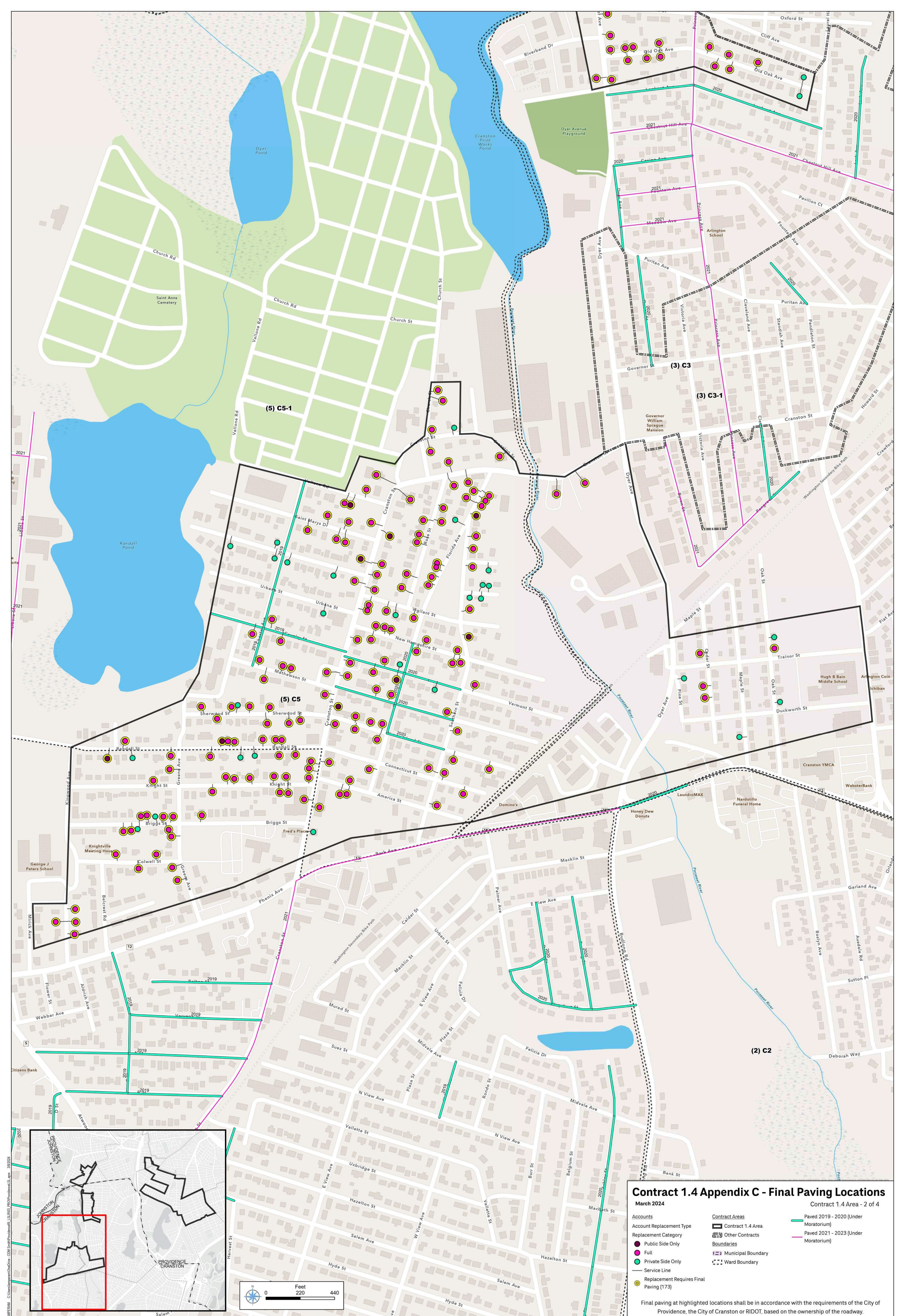

Contract 1.4 Appendix C - Final Paving Locations

March 2024
Contract 1.4 Area - 2 of 4

Accounts	Contract Areas	Paved 2019 - 2020 (Under Moratorium)
Account Replacement Type	Contract 1.4 Area	Paved 2021 - 2023 (Under Moratorium)
Replacement Category	Other Contracts	
Public Side Only	Boundaries	
Full	Municipal Boundary	
Private Side Only	Ward Boundary	
Replacement Requires Final Paving (173)	Service Line	

Final paving at highlighted locations shall be in accordance with the requirements of the City of Providence, the City of Cranston or RIDOT, based on the ownership of the roadway.

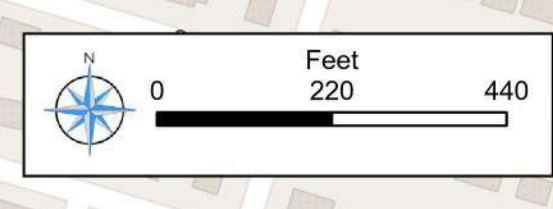
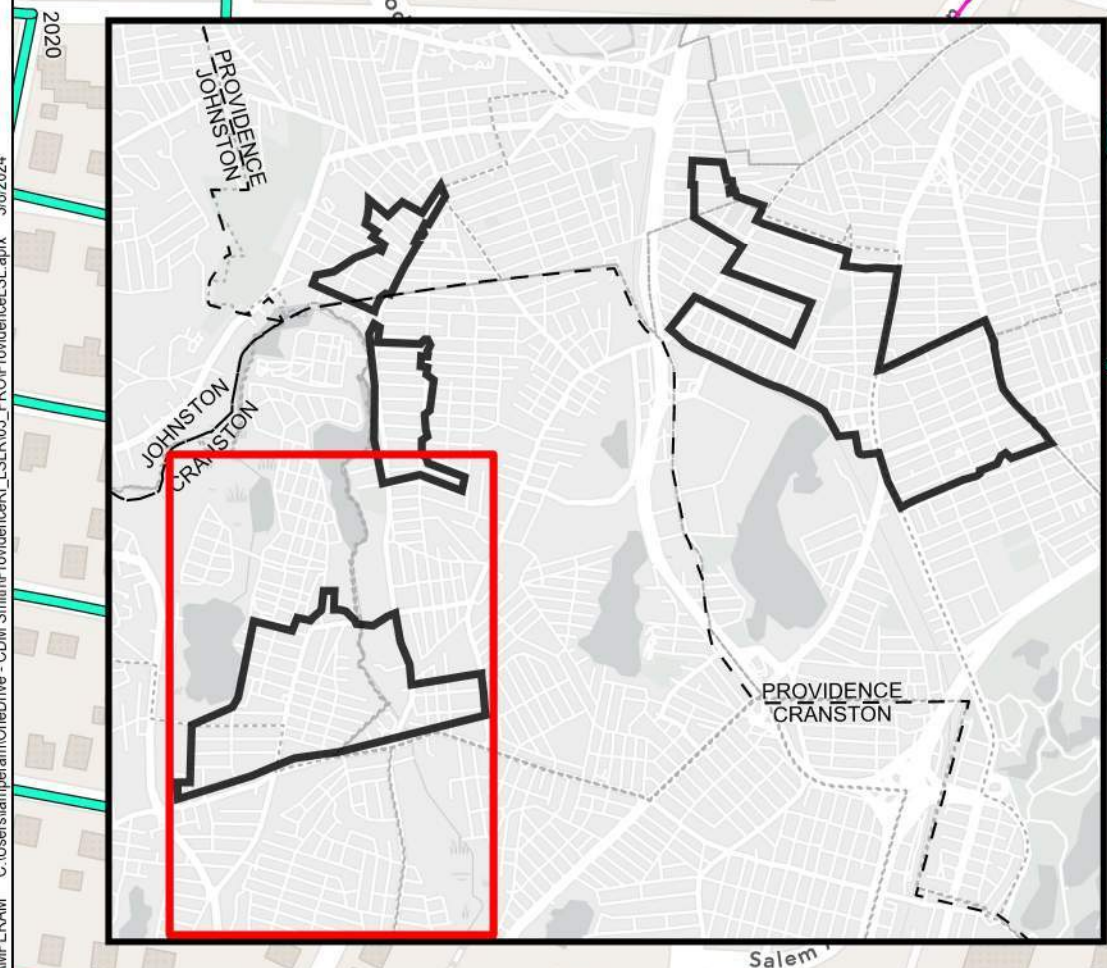

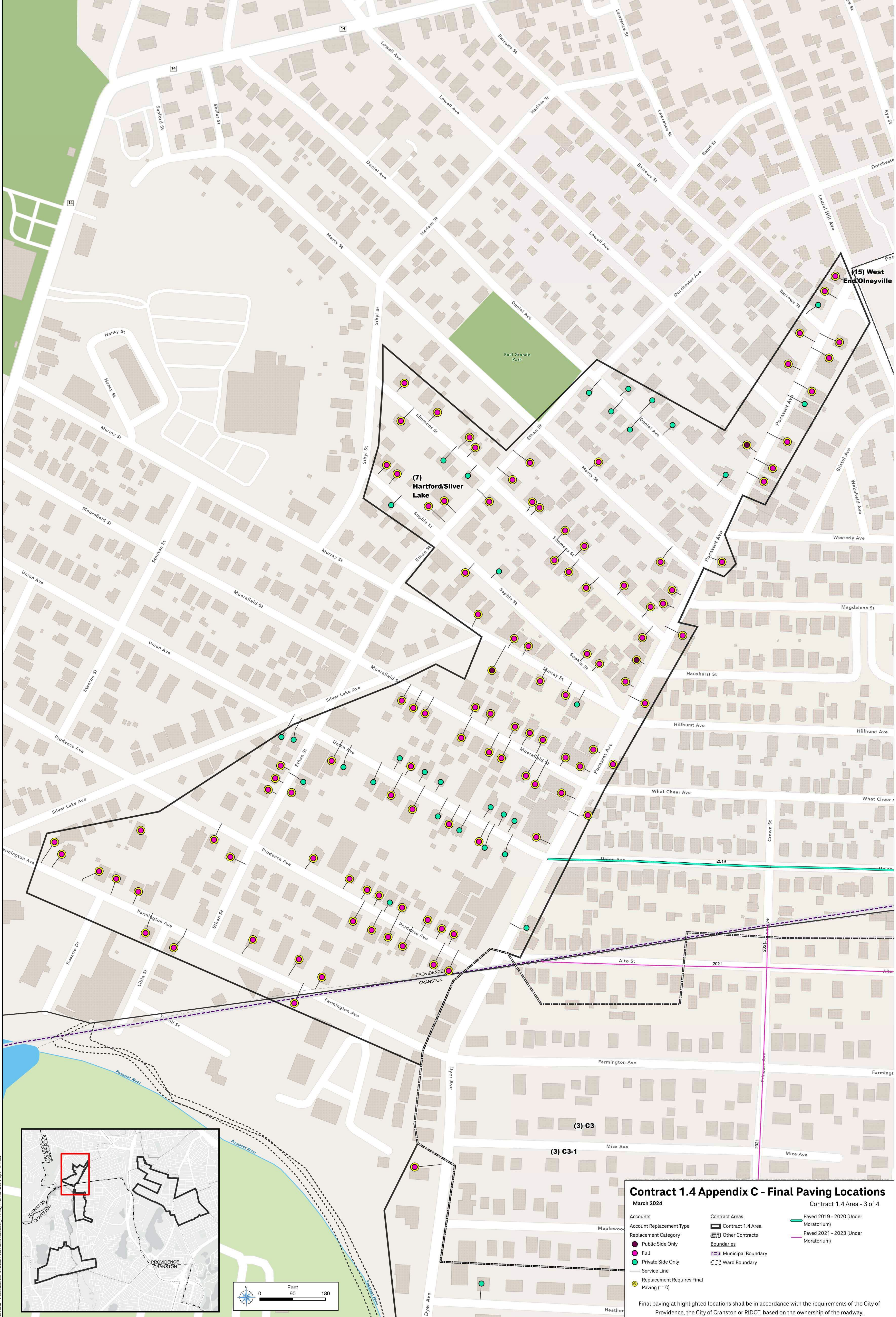

Contract 1.4 Appendix C - Final Paving Locations

March 2024

Contract 1.4 Area - 3 of 4

<p>Accounts</p> <ul style="list-style-type: none"> Account Replacement Type Replacement Category Public Side Only Private Side Only Replacement Requires Final Paving (110) 	<p>Contract Areas</p> <ul style="list-style-type: none"> Contract 1.4 Area Other Contracts <p>Boundaries</p> <ul style="list-style-type: none"> Municipal Boundary Ward Boundary Service Line 	<ul style="list-style-type: none"> Paved 2019 - 2020 (Under Moratorium) Paved 2021 - 2023 (Under Moratorium)
---	--	--

Final paving at highlighted locations shall be in accordance with the requirements of the City of Providence, the City of Cranston or RIDOT, based on the ownership of the roadway.

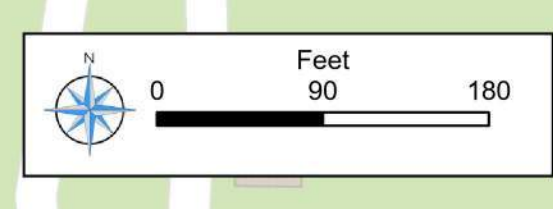
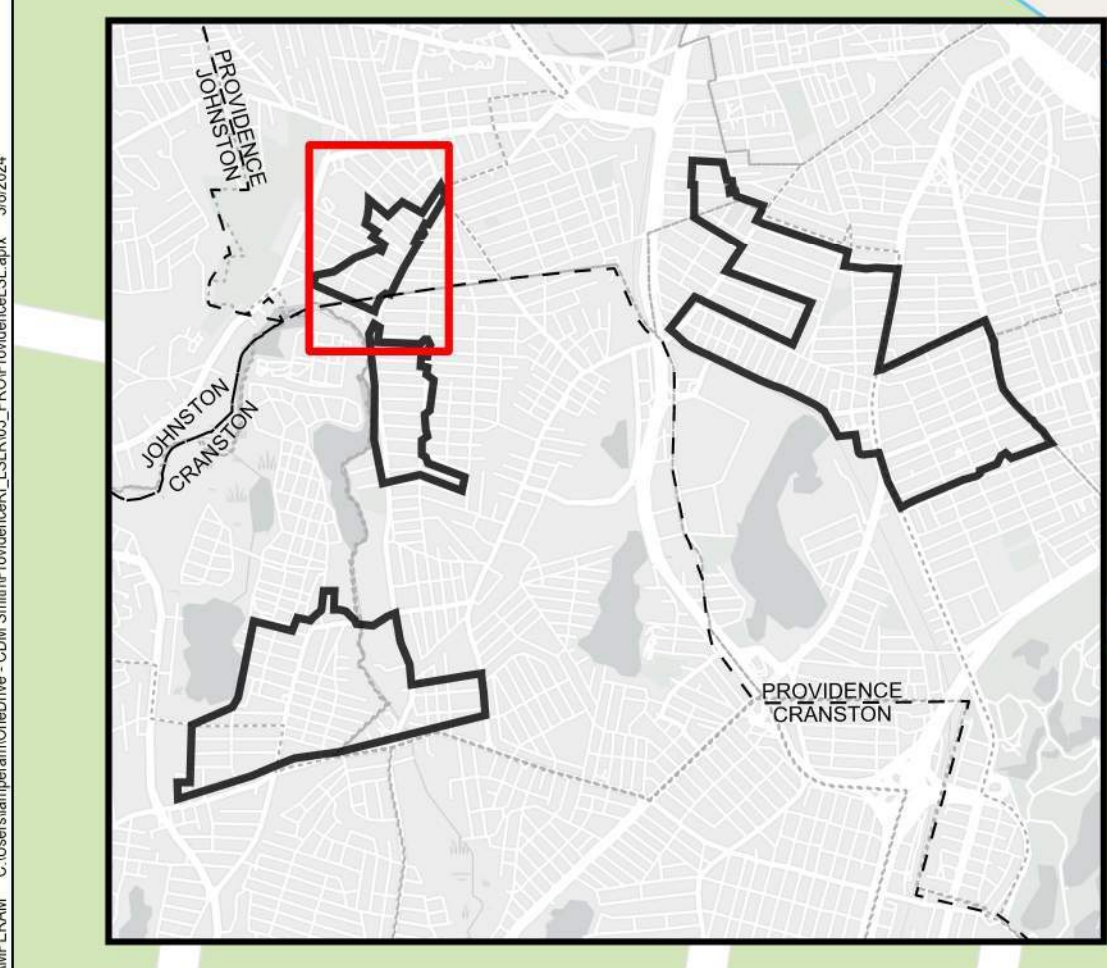

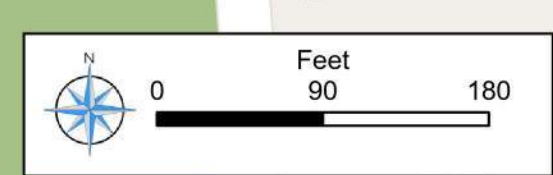
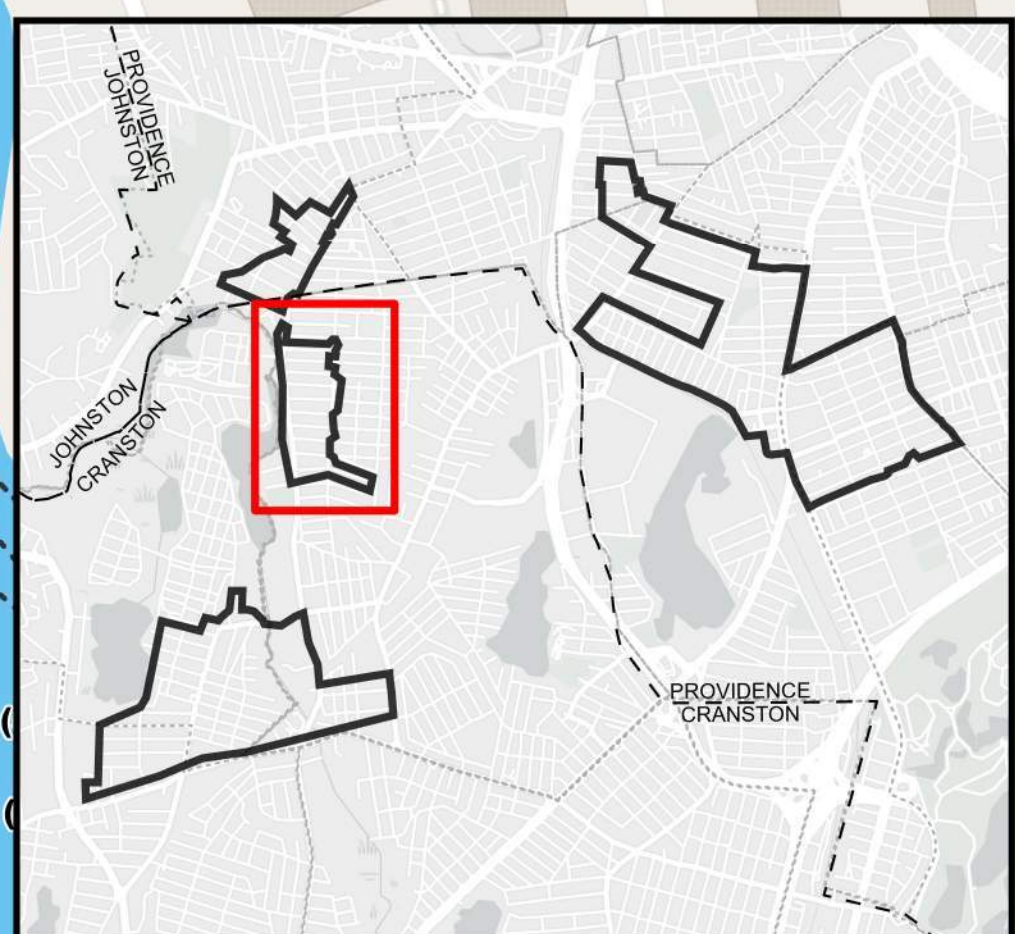

Contract 1.4 Appendix C - Final Paving Locations

March 2024

Contract 1.4 Area - 4 of 4

Accounts Account Replacement Type Replacement Category ● Public Side Only ● Private Side Only ● Replacement Requires Final Paving (26)	Contract Areas Contract 1.4 Area Other Contracts Boundaries Municipal Boundary Ward Boundary	Paved 2019 - 2020 (Under Moratorium) Paved 2021 - 2023 (Under Moratorium)
--	---	--

Final paving at highlighted locations shall be in accordance with the requirements of the City of Providence, the City of Cranston or RIDOT, based on the ownership of the roadway.

J:\PFSM - C:\Users\pfsm\OneDrive - CDM Smith\Projects\ESL\ESL_1403_PFP\Providence_Sig_2024

Appendix D

RIDOT – Minimum Standards for State and Municipal Road Repair for Utility Work



**State of Rhode Island and
Providence Plantations
Department of Transportation**

**Minimum Standards
for State and Municipal Road Repair
for Utility Work**

**Peter Alviti, Jr., P.E.
Director of Transportation**

December 18, 2019

Introduction

This document contains the Rhode Island Department of Transportation (RIDOT) standards for state and municipal roadway repair by public utilities. The standards are produced herein in conformance with Rhode Island General Laws 1956 § 39-2.2-4.

Applicability

These standards reflect the minimum standards of road repair and repaving which must be complied with on any state or municipal owned road which is disturbed for the purposes of performing utility work, in accordance with Rhode Island General Laws 1956 § 39-2.2-4. Road-owning entities may establish stricter standards via their own permitting process.

Definitions

Final pavement restoration - Last phase of the utility work consisting of returning the impacted/disturbed portions of the roadway to the same or better condition that existed prior to the utility work.

Permanent pavement structure trench - Areas/cross sections of the roadway impacted or disturbed by the utility work that require to be rebuilt and restored to full depth from the bottom up, inclusive of backfill, gravel subbase, pavement layers.

Permittee - The party performing the construction work, whether the party named in the permit or its contractor.

Rhode Island Department of Transportation Standard Specifications for Road and Bridge Construction (RIDOT Standard Specifications) - The most recent available document of that same name, published by the Rhode Island Department of Transportation, including all revisions and addendums.

Rhode Island Standard Details – The most recent available document of that same name, published by the Rhode Island Department of Transportation, including all revisions and addendums.

A. General Provisions

1. Where this document or the specifications associated with the utility permit are silent, the road repair and repaving process shall be governed by the RIDOT Standard Specifications.
2. Any property damage caused by construction associated with this process shall be repaired and/or replaced to the satisfaction of the municipality.
3. Restoration of any altered roadway shall commence immediately after the completion of the alteration, and shall include, if necessary, temporary or intermediate restoration on an ongoing basis to keep the roadway smooth and bump free until the permanent restoration can be completed.
4. Spot checks for conformance with the utility permit may include compaction testing, pavement coring, ground penetrating radar, etc. If the permit-issuing entity deems any of the utility work non-conforming, insufficient, defective or incomplete, it is the responsibility of the Permittee to complete the repairs to the satisfaction of the permit issuer.
5. The Permittee will be held responsible for maintaining the final restoration work required under the utility permit for a minimum period of five (5) years starting from the date of acceptance of all work.
6. The RIDOT Hot Mix Asphalt Matrix is incorporated into this document by reference, and shall be applicable to utility permits.
7. The Rhode Island Standard Details is incorporated into this document by reference, and shall be applicable to utility permits.
8. In accordance with the RIDOT Standard Specifications, when the Permittee mills and overlays or otherwise resurfaces an existing roadway that will be open to traffic, and such operations damage existing traffic signal loop detectors, thereby rendering such to be non-functional, the Permittee shall restore properly operating detection within seven (7) calendar days. When existing detection is rendered non-functional by the Permittee's operations for any other reason, the Permittee shall restore properly operating detection within seventy-two (72) hours.

B. In all instances of roadway opening for the purpose of performing utility work, Permittee shall

1. Saw-cut the pavement in straight parallel lines and rectangular in shape with an abrasive wheel power saw, unless otherwise specified. Under no circumstances shall the pavement cut be made using a hammer or drop weight. All pavement cuts shall be full depth through the pavement; and,
2. Backfill in maximum one (1) foot lifts and place at minimum twelve (12) inches of gravel subbase, compacted to RIDOT Standard Specifications.

- C. When installing temporary patching on all excavations which will not be permanently restored within the same working day, Permittee shall place a minimum two (2) inch temporary hot mix asphalt pavement patch each day after completion of work in a roadway segment.
- D. When performing permanent pavement structure trench restoration
1. Permittee shall re-sawcut, full depth through the pavement, one (1) foot cutbacks at minimum from all vertical edges of the initial utility work trench(es) prior to installing permanent pavement.
 2. Permittee shall apply asphalt emulsion tack coat to all vertical and horizontal pavement surfaces prior to permanent pavement structure trench restoration.
 3. For state-owned roads, at a minimum, the restored pavement thickness shall match the existing depth of the roadway, or equal six (6) inches, whichever is greater. For non-state-owned roads, at a minimum, the restored pavement thickness shall match the existing depth of the roadway, or equal four (4) inches, whichever is greater.
 4. Class(es) of hot mix asphalt for permanent pavement shall be in accordance with the RIDOT Hot Mix Asphalt Matrix.
 5. If concrete base is present in the roadway, restoration shall include Class XX concrete and dowels, in accordance with the RIDOT Standard Specifications.
 6. The full depth permanent pavement structure trench shall be in place for a minimum thirty (30) calendar days, and for a maximum one (1) year or sooner in accordance with the municipal permit, prior to final pavement restoration.
 7. Permittee shall restore:
 - a. Full panels of impacted concrete sidewalk in accordance with RI Standard 43.1.0;
 - b. Full panels of impacted concrete driveways in accordance with RI Standard 43.5.0;
 - c. Impacted asphalt sidewalk full width in accordance with RI Standard 43.2.0 using Class 4.75 or 9.5 hot mix asphalt;
 - d. Impacted asphalt driveways full width using Class 9.5 hot mix asphalt;
 - e. Impacted curbing (replace) in kind and reset to original grade; and
 - f. Impacted plantable areas with loam and seed.
- E. Final pavement restoration shall include:
1. Two (2) inches of micromilling and resurfacing all impacted travel lanes and/or shoulders for their full width using Class 9.5 or 12.5 hot mix asphalt. Impacted travel lanes and/or shoulders are the roadway pavement areas that the utility work trench(es) are located within. In addition to the roadway pavement areas impacted by the utility work trenches, this final pavement restoration shall also apply to all travel lanes and/or shoulders impacted by either lateral or longitudinal utility work trenches when the trenches are less than or equal to one hundred (100) feet longitudinal from one another, including the sections

between trenches, so that no section(s) of roadway pavement less than or equal to one hundred (100) feet shall remain unpaved. This will provide a continuous final pavement between the utility work trenches.

2. Permittee shall apply asphalt emulsion tack coat to all vertical and horizontal pavement surfaces prior to final resurfacing.
3. Restoring permanent pavement markings in the same locations as originally located with epoxy resin paint, as per the RIDOT Standard Specifications.
4. Permanent epoxy resin pavement markings shall be placed no sooner than two (2) weeks but no later than four (4) weeks from the completion of the paving operation.
5. After final paving, as well as before permanent pavement markings are installed, Permittee shall install temporary waterborne reflectorized pavement markings, placed in the same locations as original markings, on any roadways opened to traffic at the completion of any day's paving operation.

Answers to Frequently Asked Questions:

1) **Q:** Why are you sending us this document.

A: The recently enacted, “THE RHODE ISLAND UTILITY FAIR SHARE ROADWAY REPAIR ACT,” (R.I. General Laws 1956 § 39-2.2) includes a provision that requires “any repaving and repair of a municipal road required by § 39-2.2-2 shall be in accordance with standards promulgated by the director of the department of transportation.”

2) **Q:** What is the purpose of this law?

A: The act requires public utilities to restore roadways which they altered or excavated to the satisfaction of the state or municipality controlling the roadway. It also allows for financial recovery for defective or incomplete work.

3) **Q:** What information is contained in this document.

A: This document sets the minimum roadway restoration requirements or “standards” that must be met when utility excavation or alteration work is performed in a public roadway. These standards apply to both temporary and permanent restorations.

4) **Q:** Can a Municipality choose to set its own roadway restoration standards in place of these standards.

A: A Municipality can choose to adopt, or keep in place, additional permit requirements as long as these minimum standards are met or exceeded. This document outlines only the minimum restoration standards for roadway restorations.

5) **Q:** Do these roadway restorations standards differ from RIDOT’s permit requirements?

A: No, they do not differ. However, RIDOT may require that higher restoration standards be met on State owned roadways.

6) **Q:** What role will RIDOT have in the implementation of these standards on a local roadway.

A: RIDOT will have no role in the implementation, oversight, or enforcement of these standards.

7) **Q:** Would a Municipality be in full compliance with the law if it implements these standards.

A: Yes. This document establishes the minimum standards for roadway repair on both state and municipal owned roads following utility work. Municipalities, through their own respective permitting processes, are free to impose requirements that meet or exceed those stated herein. This document does not bear on a Municipality's authority to oversee or enforce roadway repair standards within its jurisdiction.

Appendix E

City of Providence – Standards to be Employed by Licensed Sidewalk Contractors for Road and Sidewalk Openings



CITY OF PROVIDENCE

Effective: November 20, 2017

STANDARDS TO BE EMPLOYED BY LICENSED SIDEWALK CONTRACTORS FOR ROAD AND SIDEWALK OPENINGS

I. Introduction

The public safety and convenience require both the installation and maintenance of utility services and the maintenance and restoration of safe and aesthetically pleasing roadways and sidewalks. These requirements unfortunately are sometimes in tension. Safe streets and sidewalks are unquestionably necessary and aesthetically pleasing highways are highly desirable. The public, though, has the right to expect the availability and delivery of both existing and improved or new utility services, to be provided in a safe and efficient manner.

The city seeks to allow the delivery of the expected services yet ensure public safety and the quality of life to which the city's citizenry is entitled. That goal requires the balancing of two (2) important dynamics. The city seeks to promote the prompt and safe delivery of old and new services without sacrificing the peoples' safety and convenience.

These Rules and Regulations are promulgated to assist contractors on the proper standards to be employed for public roadway and sidewalk opening. The authority for such promulgation is found in the City of Providence Code of Ordinances, Section 23-6 (Opening, excavating, etc., on, in, across or under public roadway or sidewalk) and specifically Section 23-6 (d) which states, "*The director shall promulgate such rules and regulation as may be necessary to effect the purpose of this article...*"

II. Applicability

These regulations apply to all applications for excavation or construction which fall within the parameters described below. Other applications continue to be governed by State law, such as R.I.G.L. § 24-7-1 (Sidewalks.) Failure to comply with these rules and regulations will result in a \$250-\$500 fine for each occurrence.

Excavation or construction in the Public Right-of-Way require the issuance of road opening permits. Road opening permits are only issued to Providence Sidewalk Contractors. Providence sidewalk contractor licences are issued to those who fill out an application, submit an application fee and provide proof of insurance and performance bond.

Sidewalk repair and/or curb alterations require the issuance of a Physical Alteration Permit. Physical Alteration Permits may be issued to a Providence Sidewalk Contractor, or Limited Providence Sidewalk Contractors. Limited sidewalk contractors have the same requirements as a full sidewalk contractor, with a lesser performance bond amount. Limited Providence Sidewalk Contractors may only be issued Physical Alteration Permits. Providence Sidewalk Contractors may be issued road opening permits and physical alteration permits.

A Geotech/Boring Sidewalk Contractor license will be issued to business seeking to perform vertical drill borings in the public right of way.

III. Standards to be Employed by Licensed Sidewalk Contractors for Road and Sidewalk Openings

Section

- 1.0 Purpose and Scope
- 2.0 Definitions
- 3.0 Permit Requirements
- 4.0 Work Standards
- 5.0 Safety
- 6.0 Protection of Adjoining Facilities
- 7.0 Excavations
- 8.0 Backfill and Compaction
- 9.0 Pavement Restoration
- 10.0 Striping and Traffic Detection Loop Restoration
- 11.0 Sidewalks and Driveways
- 12.0 Physical Alteration Permits
- 13.0 Other Permits
- 14.0 Clean up

1.0 Purpose and Scope

1.1 All aspects of rendering utility service – new installations, repair/maintenance and upgrading – are critical to the public welfare. The purpose of these standards are to ensure that a Permittee, after excavating City of Providence, any street, lane, highway ("public ways"), and sidewalk restores such street, lane, highway and sidewalk to the new restored condition. This includes restoring bituminous asphalt paving, decorative paving in streets, sidewalks and crosswalks, restoring epoxy resin traffic pavement markings and traffic loop detectors with in-kind materials.

1.2 These standards are developed and enforceable under the Providence Code of Ordinances, Part II, Section 23-6 – *Opening, excavating, etc., on, in, across or under public roadway or Sidewalk* and Article III – *Construction and Repair of Sidewalks*

1.3 Hundreds of complaints are received each year regarding failed road/sidewalk openings and road/sidewalk openings that have not been restored to the new restored condition including pavement/sidewalk condition, pavement markings, traffic detection loops and specialty paving. All efforts shall be taken to expedite the work and final restoration.

1.4 The Standards set forth herein, including specific performance requirements for excavation, backfilling, resurfacing and striping of roads are intended to establish uniform requirements for street opening work in the City. These Standards shall apply to excavations within streets, sidewalks and the Public Right of Way.

1.5 The Permittee is responsible for ensuring compliance, for itself and its contractors, with these standards. However, work may be inspected by the City to assure that proper procedures are being followed. In the event a Permittee fails to comply with these standards a Permittee shall, at its own expense, correct such failures. Failure to comply may result in revocation of existing permits, refusal to issue new permits, revocation of Sidewalk Contractor License or monetary fine, completion of work

through the Contractor's bond, or the City to correct the failures with the cost passed to the Sidewalk Contractor.

1.6 The Permittee shall work with the City to minimize the impact of street openings and specifically, to reduce the incidence of non-emergency excavations in newly-paved streets.

1.7 The Standards may be amended at any time and shall become effective immediately.

2.0 Definitions

AASHTO means The American Association of State Highway and Transportation Officials.

ADA means The Americans with Disabilities Act, which prohibits discrimination against individuals with disabilities. The ADA provides standards and regulations for State/local governments, in providing equal opportunity and access to all public facilities, including sidewalks, wheelchair curb ramps and public spaces. <https://www.access-board.gov/guidelines-and-standards/streets-sidewalks/public-rights-of-way/proposed-rights-of-way-guidelines>

City means the jurisdiction of the City of Providence, having subordinate and local powers of legislation

Clay means very finely textured soil which, when moist, forms a cast which can be handled freely without crumbling/breaking; that exhibits plasticity; and when dried, breaks into very hard lumps (*i.e.*, high dry strength) and is difficult to pulverize into a soft, flour-like powder.

Cold Patch means a bituminous concrete made with slow curing asphalts and used primarily as a temporary patching material when hot mix plants are closed.

Compaction means compressing of suitable material and gravel that has been used to backfill an excavation by means of mechanical tamping to within 95% of maximum dry density as determined by the modified Proctor test in accordance with AASHTO, T180.

Controlled Density Fill ("CDF), also called flowable fill, means a mixture of portland cement, fly ash, sand and water. High air (25% plus) may be used instead of fly ash with an adjustment in sand content. CDF is hand-tool excavatable.

Curb Cut means the installation of a break in the curb to allow vehicles access from a roadway to private property.

Decorative Paving means street and sidewalk treatments that deviate from the traditional asphalt and concrete surfaces, such as bricks, pavers, cobblestones, stamped concrete, stamped synthetic paving, exposed aggregate, etc.

DPW means the City of Providence Department of Public Works

Emergency Repair Work means street opening work which must be commenced immediately to correct a hazardous condition whose continuation would unreasonably risk injury, loss of life or property damage.

Gravel means coarse to very coarse-grained soil ranging from approximately 0.1 inch to 3.0 inches. Gravel exhibits no plasticity.

Guaranteed Road means a road whose pavement surface is less than five years old.

Infrared Process means a restorative procedure whereby an infrared heater plasticizes the surface of an asphalt pavement, preparatory to the introduction of additional compatible paving materials uniformly re-worked and compacted to achieve a density and profile consistent and thoroughly integrated with the adjacent pavement.

MUTCD means the Manual on Uniform Traffic Control Devices. The MUTCD is the standard for signs, signals and pavement markings in the United States. <https://mutcd.fhwa.dot.gov/>

Organic Soil means soil high in organic content, usually dark (brown or black) in color. When considerable fibrous material is the principal constituent, it is generally classified as "peat." Plant remains or woody structures may be recognized and the soil usually has a distinct odor. Organic soil may exhibit little (or a trace of) plasticity.

Permanent Patch means a final repair of street opening work to be performed in accordance with these standards and intended to permanently return the opened portion of the roadway to as good a condition as it was prior to the performance of the street opening work.

Permit means a permit granted by the City to a Licensed Sidewalk Contractor for permission to work in the public right-of-way.

Permitee means a Licensed Sidewalk Contractor with the City of Providence, who has submitted an application, proof of general liability insurance and bond and maintains such as a condition of the license.

Physical Alteration Permit means a permit issued for performing sidewalk and driveway repairs and curb alterations. A Physical Alteration Permit may also be issued for installation of signs, or other permanent objects in sidewalks, medians or other features in the Public Right of Way. A Physical Alteration Permit is not issued for utility work.

Plasticity means that property of soil that allows it to be deformed or molded without crumbling (e.g., like dough or soft rubber). This property reflects the capacity of soil to absorb moisture.

Poorly Graded Soil means soil that contains a large percentage of its constituent particles within a relatively narrow range; also referred to as "uniform" soil.

Protected Street means a road or street whose pavement surface is less than 5 years old.

Providence Standard Details means construction details specific to the City of Providence. Standard details may be found on the following webpage under "Reports + Publications."
<https://www.providenceri.gov/wp-content/uploads/2017/04/Providence-DPW-Standard-Details.pdf>

RI Highway Standards means the "Rhode Island Department of Transportation Standard Specifications for Road and Bridge Construction, including all revisions, addenda and updates."
<http://www.dot.ri.gov/business/bluebook.php>

RIDOT means the Rhode Island Department of Transportation.

Same Day Hot Patching means the installation of a permanent patch (“same day patch” on an excavation within one (1) business day of completion of the utility work.

Sand means coarse grained soil in which the individual grains can be visually detected. When moist it forms a cast which will crumble when lightly touched; when dry, it will not form a cast and will fall apart when confining pressure is released. Sand exhibits no plasticity.

Silt means finely-textured soil. When moist, it forms a cast which can be freely handled; when wet, it readily puddles; when dry, it may be cloddy and readily pulverizes into powder with a soft flour-like feel (*i.e.*, low dry strength). Silt exhibits little or no plasticity.

Street Opening Work means any cutting excavating, compacting, construction, repair or other disturbance in or under a public way together with restoration of the public way in accordance with these standards, municipal ordinances, and any other applicable law following such disturbance.

Temporary Patch means the interim application of either cold patch or Class 9.5mm bituminous concrete compacted to achieve a density equal to that of the surrounding pavement.

Well Graded Soil means soil having its constituent particles within a wide range, also referred to as "non-uniform" soil.

3.0 Permit and Notice Requirements

3.1 The issuance of a permit by the City shall be subject to these Standards. A permit shall be issued with the stipulation that it may be modified or revoked with just cause at any time at the discretion of the City without rendering the City liable in any way. The City shall have the authority to inspect work in progress and the permittee shall correct any deficiencies identified during said inspections. The following are the requirements that the City requires when granting permits.

3.2 The work shall be performed in accordance with plans on file with the City.

3.3 The Permittee shall notify Dig Safe, in accordance with R.I.G.L. §39-1.2 *et seq.*, at least 72 hours prior to the start of work for the purpose of identifying the location of underground utilities. The Permittee shall be responsible to obtain the field location of any underground traffic control devices and sewer locations from the City. The City does not provide Dig Safe services for these facilities. The Permittee may contact the Traffic Engineer for locations of underground traffic control device locations the Engineering Department for sewer location information.

3.4 A copy of the Permit must be on the job site at all times for inspection (except for emergency repair work). Failure to have the Permit available could result in suspension of the rights granted by the Permit, suspension of Sidewalk Contractor license and/or a monetary fine. Traffic Engineering Permits must be obtained prior the start of work, including but not limited to road closures, lane closures, parking restrictions, sidewalk closures and detours. In the event of emergency repair work, a permit shall be requested within twenty-four (24) hours of the work being performed.

3.5 Work, day, and time constraints shall be conditions of the Permit. As stated in Providence Code of Ordinances, Part II, Chapter 16, Article III – *Noise Control*, it is unlawful to operate machinery or equipment exceeding fifty-five (55) dBA between the hours of 8:00PM and 7:00AM. Requests to work

during the restricted hours shall be formally requested to the Director of Public Works, with an explanation of the work to be performed, equipment to be used and a reason for requesting night work.

3.6 If it becomes necessary to open the roadway surface in a larger area than specified in the Permit, the permittee shall amend the Permit to cover the project.

3.7 No portion of the work shall be sublet to any subcontractor without first giving the City due notice in writing of such intention. No subcontractor shall be employed who is unsatisfactory to the City.

3.8 The Permittee shall employ only competent and efficient laborers, operators and artisans for every kind of work, and whenever, in the opinion of the City, any person is unfit to perform their task, or does their work contrary to directions, or conducts themselves improperly, the permittee shall remove that person from the job site.

3.9 The Permittee shall notify the Engineering Division when the temporary restoration AND final restoration has been completed, including all specialty paving, roadway striping and traffic detection loop restoration by the permit end date. If more time is required, the Contractor shall request the permit be amended and charged an additional permit fee. The five year restoration warranty period begins on the date of final restoration and lasts five years from said date. Physical Alteration Permits require notification when all work is complete. The Contractor may request an inspection prior to pouring concrete to ensure the proposed facility complies with the Standards.

4.0 Work Standards

4.1 All work shall be in compliance with these *Standards to Be Employed by Licensed Sidewalk Contractors for Road and Sidewalk Openings*, Providence Standard Details and RI Highway Standards as it pertains to utility street excavations and repairs unless modified by these standards. Where any two standards are similar, the City Standard shall prevail.

4.2 The Permittee shall be responsible for any failure or settlement that may occur as a result of the work done in accordance with the Permit. The Permittee is responsible for the settlement of a patch (0.25" vertical difference or greater) for five (5) years from the completion of the final restoration.

4.3 The Permittee shall be responsible for the ponding of water that may develop within the roadway which was caused by this work.

4.4 In the event a street opening failure presents a nuisance or a public safety issue, the Permittee shall respond to protect the opening from all modes of traffic within one hour of notification. Repairs shall begin within 24 hours or sooner if specified by the City.

Street opening failures that do not present a nuisance or a public safety issue shall be repaired within thirty (30) calendar days, including striping and traffic detector loops.

Non-response within the specified time may result in the required restoration work being done by the City, with all expenses to be paid by the Permittee. The Permittee shall reimburse the City for the invoiced amount within thirty (30) days. Failure to reimburse the City will result in refusal to issue permits or the revocation of the sidewalk contractor's license. Additionally, the City may seek to have the work performed through the Permittee's performance bond.

If a failure develops within the Permittee's excavation or the vicinity of the excavation, within five years of the final restoration date, the Permittee will be responsible for repairing the failure.

5.0 Safety

5.1 Provisions shall be made for the safety and protection of pedestrian, bicycle and motorized traffic during the construction period. All required Traffic Engineering permits, including but not limited to road closures, lane closures, parking restrictions, sidewalk closures and detours shall be obtained prior to work starting and shall be maintained on site.

5.1.1 In most instances, work on the sidewalks reduces the path of travel to less than the American's with Disabilities Act (ADA) minimum width of four feet, resulting in the temporary closure of the sidewalk.

5.1.2 When it is necessary to close access to a sidewalk, the Permittee must notify all pedestrians that the sidewalk is closed by placing appropriate MUTCD compliant signage at the closest pedestrian access ramps at either end of the sidewalk being worked on. Signs must only be placed where there is both a crosswalk and a corresponding pedestrian access ramp across the street allowing individuals requiring mobility assistance to safely and successfully cross the street. Temporary, ADA compliant plywood or asphalt ramps may be suitable where no existing pedestrian access ramp is present.

5.2 The Permittee shall be responsible to furnish and erect all required signs and traffic safety devices.

5.3 Cones and non-reflecting warning devices shall not be left in operating position when the daytime operations have ceased. If it becomes necessary for the City to remove any construction warning devices or the appurtenances from the project due to negligence by the Permittee, all cost for this work will be charged to the Permittee.

5.4 Flashing arrow boards will be used as indicated in the Traffic Engineering permit when operations occupy the roadway and shall be available for use at all times.

5.5 All signs and devices shall conform to the current edition of the Manual on Uniform Traffic Control Devices (MUTCD).

5.6 Efforts shall be made to maintain normal traffic flow, but interruptions or obstructions to traffic shall be defined by conditions of the Permit.

5.7 When, in the opinion of the City, the work constitutes a hazard to traffic in any area the Permittee may be required to suspend operations during certain hours and to remove any equipment from the roadway.

5.8 When a snow or ice condition exists during the progress of this work, the Permittee shall keep the area affected by the work safe for travel. The City may restrict work during snow, sleet, or ice storms and subsequent snow removal operations.

5.9 The road and sidewalk surface shall be kept clean of debris at all times and shall be thoroughly cleaned at the end of each work day.

5.10 At the completion of the work done in accordance with the Permit, all disturbed areas shall be restored.

5.11 Blasting, if necessary, shall be done in accordance with state law and local ordinance.

5.12 All federal, state, and local safety regulations shall be followed.

5.13 In connection with the Permit, the Permittee shall assume no greater responsibility for risks and casualties of every description, for loss or injury to persons and property arising out of the nature of the work, from the action of the elements or from any unforeseen or unusual difficulty, than is otherwise imposed by law.

5.14 If, in the exercise of its discretion pursuant to Section 3.0, the City should determine on the basis of factors affecting safety and health that a street opening failure presents a nuisance or a public safety problem, the Permittee shall respond to a request by the City within one hour to secure, stabilize and protect the site. The permittee shall begin emergency repairs within twenty four (24) hours of the request. Non-response within the specified time may result in the required restoration work being done by the City, with all expenses to be invoiced to the Permittee. The Permittee shall reimburse the City for the invoiced amount within thirty (30) days.

5.15 Failure to respond to trench restoration requests shall result in denial of future permit requests and/or revocation of the Sidewalk Contractor's License.

5.16 No vehicles, equipment, stockpiles, materials or other incidental items are permitted in the Public Right of Way outside of working hours. The site must be cleaned and restored at the end of each work day. Patches may be plated with appropriate signage if work will resume the next day. Plates must be secured to prevent movement and edges ramped with bituminous material. All other excavations shall be patched with bituminous concrete, with no exposed gravel. Fines may range from \$250-\$500 for failure to comply.

6.0 Protection of Adjoining Facilities

6.1 Care must be taken to not interfere with underground structures that exist in the area. The Permittee shall be responsible to obtain the field location of sewer locations and underground traffic control devices from the Department of Public Works.

6.2 Care shall be exercised not to disturb any subsurface traffic duct system. Any such system, if disturbed, shall be restored immediately to its original condition. Any traffic loop detector, if disturbed, shall be replaced immediately. The Permittee shall be responsible to obtain the field location of any underground traffic control devices from the Traffic Engineering Department.

6.3 The Permittee shall be responsible to replace all pavement markings in kind which have been disturbed as a result of work done in accordance with the Permit. These pavement markings shall be temporarily replaced at the end of each work day by use of appropriate signage, lighted safety barrels and asphalt markings approved by the City. These pavement markings shall be permanently restored; utilizing epoxy resin 15-30 days after the final restoration has been completed, or as deemed necessary by the City

6.4 Existing guardrail that may be removed or damaged shall be replaced to current RI Highway Standards.

6.5 The Permittee will be responsible for any damage caused by its operation to curbing, structures, roadway, trees, private property, etc.

6.6 Tree pruning should occur prior to any roadwork to accommodate the height of machinery. For any pruning, the contractor needs to hire an arborist with a RI Arborist license to perform the pruning. The forestry division should review the work prior to pruning. All pruning shall conform to the American National Standards Institute standard for Tree Care Operations – Pruning (ANSI A300), to the satisfaction of the City Forester. If damage occurs, branches of any size should be pruned by a licensed arborist back to a larger lateral branch or the trunk, as per ANSI A300 standards.

6.7 Hand digging shall be required around roots of trees. No mechanized or pneumatic equipment shall be permitted to be used around tree roots.

6.8 Tree Removal

6.8.1 The Permittee shall obtain written permission from the City Forester if it becomes necessary to remove any tree. Replacement trees must be obtained from an established nursery in accordance with "USA Standard for Nursery Stock". The trees will be replaced in size and species as directed by the City Forester.

6.8.2 The tree stump shall be removed a minimum of six inches below the surrounding surface and all debris shall be disposed of outside the right-of-way line.

6.8.3 The tree shall be removed under the supervision of a qualified tree surgeon.

6.9 Every effort shall be made to protect bound markers. However, if it becomes necessary to remove and reset any bound marker, the Permittee shall hire a Rhode Island Registered Professional Land Surveyor to perform this work. It shall be the responsibility of this land surveyor to submit to the City a statement in writing and a plan containing his stamp and signature showing that said work has been performed.

6.10 Sediment and Erosion controls (i.e. Silt sacks and hay waddles) should be installed and maintained at all adjacent and downstream inlets and catch basins. Failure to install and maintain may result in the City ordering the Permittee to clean effected drainage structures, or the City may clean the structures and invoice the Permittee. Failure to adhere may result in revocation of permit, refusal to issue future permits, monetary penalties and/or revocation of the Sidewalk Contractor's License. If, for any reason, the work on the project is delayed or interrupted, all sediment and erosion controls shall be removed and the work stabilized until such time as the work commences again.

7.0 Excavations

7.1 The surface of a roadway and/or sidewalk to be excavated for utility work shall be cut in straight and parallel/perpendicular lines using a saw to insure the least amount of damage to the roadway surface. The pavement, including reinforcing steel on concrete roadways, shall be cut full depth. The excavation shall only be between these lines. The cutting operation shall not be done with a backhoe, gradall or any type of ripping equipment. If necessary to extend the excavation beyond the original limits, the excavation shall be sawcut.

7.2 If steel plates are used by a Permittee to protect an excavation, they shall be of sufficient thickness to resist bending, vibration, etc., under traffic loads and shall be anchored securely to prevent movement. If these conditions are not met, the Permittee will be required to backfill and pave the excavations daily. No open trench shall be left unattended overnight. MUTCD compliant signs shall be installed warning motorists, bicyclists and pedestrians of the plate.

7.3 Sheeting, shoring or bracing, if employed, shall be left in place and cut off three (3) feet below the surface at the discretion of the City.

7.4 Excavations shall be signed in accordance with the applicable MUTCD standards.

7.5 If it is necessary to dewater any excavation, the Permittee must obtain the necessary authorization for the discharge of the groundwater. The City reserves the right to require whatever means necessary so as not to impact the sewer system.

7.6 Excavations in sidewalks shall be protected from pedestrian traffic by means of barrels and safety tape.

8.0 Backfill And Compaction

The following provisions set forth general guidelines and criteria to determine whether a soil is suitable as backfill for street work excavations in restoring municipal streets, lanes and highways and sidewalks. Permittees may utilize approved backfill material compacted to achieve soil density values of 95% modified Proctor density (as described in AASHTO T180), which may include, as the conditions warrant and in the discretion of the City, the use of Controlled Density Fill. The objective is to obtain a finished road repair which will settle within acceptable performance limits (no more than 0.25 inches) as defined within these standards for the functional life of the existing road. The guidelines are based on good engineering practice and testing of both materials and equipment. Compliance with these Standards will promote satisfactory backfill compaction.

8.1 In restoring City streets, the permittee shall use appropriate fill for excavations, in compliance with the Standards set forth below with respect to backfill suitability, and shall compact all fill to achieve soil density values of ninety-five percent (95%) modified Proctor density (as described in AASHTO T180). The use of the existing soil for backfilling is preferred provided it meets the suitability requirements and is able to be properly compacted.

8.2 Compliance with these standards will insure satisfactory compaction. These standards are to be used in the field when there is an absence of sieve analysis of materials, Proctor values of the soils and the corresponding inability to utilize a nuclear density gauge or sand cone field density test. The Permittee shall have the right, at its own expense, to verify compaction through an independent, qualified engineering consulting firm. In the event of test failure, the Permittee shall be responsible for re-compacting the excavation to meet the required standards.

8.3 Suitability of Backfill Material

8.3.1 Suitable backfill material is free of stones larger than half the size of the compacted lift as provided for in RI Highway Standards, construction debris, trash, frozen soil and other foreign material. It consists of the following:

- a. Well graded gravel and sand;
- b. Poorly graded gravel and sand;

- c. Gravel-sand mixtures with a small amount of silt;
- d. Gravel-sand mixtures with a small amount of silt and trace amounts of clay.

8.3.2 Unsuitable backfill materials consist of the following:

- a. Inorganic silts and clays;
- b. Organic silts;
- c. Organic soils including peat, humus, topsoil, swamp soils, mulch, and soils containing leaves, grass, branches, and other fibrous vegetable matter.

8.4 Evaluation of Excavated Soil

8.4.1 The soil excavated from a trench may be evaluated by the City to determine whether or not it is suitable as a backfill in accordance with Subsection 8.3.

8.4.2 An excavated soil that has been evaluated as suitable for backfill shall be reused upon completion of the work.

8.4.3 The Permittee shall have the right, at its own expense, to verify backfill suitability through an independent, qualified engineering consulting firm.

8.4.4 An excavated soil that has been evaluated as unsuitable for backfill shall be removed from the site and disposed of properly. New material, which meets the requirements of Subsection 8.3, shall be brought in to replace excavated soil found to be unsuitable.

8.5 Backfill And Compaction Of Excavations

8.5.1 Backfill and compaction shall be performed in accordance with RI Highway Standards, Section 301.03.2. Granular backfill shall be placed in lifts not exceeding six (6) inches.

8.5.2 All leak detection holes (*i.e.*, bar holes) shall be filled in lifts with an appropriate mineral filler and compacted to the bottom of the pavement.

8.6 A color coded marking tape shall be placed in an appropriate location below final grade above all underground utility installations, except sewers and drains running in straight lines between surface catch basins, manholes, or posts identifying the underground installation. Tape shall be durable, non-degradable plastic, not less than two (2) inches wide and in the following colors for the particular underground utility:

Blue	-	Water
Red	-	Electric Cable
Yellow	-	Gas
Orange	-	Telephone
Green	-	Sewer

9.0 Permanent Restoration

9.1 The Permittee shall be responsible to replace all pavement, sidewalks, pavers, grass and decorative paving disturbed by work under the Permit with homogeneous and in-kind pavement, unless otherwise stipulated. The Permittee shall be responsible to replace all pavement disturbed by work under the permit using (i) same day hot patching, (ii) grind and inlay, or (iii) temporary patch followed by

permanent patch, all as specified to at least the original strength and condition unless otherwise agreed. All repairs shall comply with Providence Standard Details.

9.2 Restoration Preparation - After performance of the procedures prescribed by the Standards relating to backfilling and compaction, the adjacent pavement shall be cut back a minimum of twelve inches (12”), full depth to encompass all disturbed pavement areas and underlying cavities associated with the excavation. All cutbacks shall be done in straight, continuous lines. Existing pavement surfaces shall be swept clean of dirt, dust, and debris prior to patching. The existing vertical pavement surfaces and all interfaces where layers of bituminous concrete are installed shall be coated with an appropriate asphalt tacking material (tack coat) prior to patching and subsequent to cleaning.

9.3 Permittees shall comply with the following standards in restoring pavement:

9.3.1 Pavement repair depths shall equal or exceed adjoining pavement depth, with a minimum asphalt depth of three inches. When existing pavement depths including penetrated stone base are greater than 3 inches, pavement repairs shall be made utilizing Class 9.5mm base course or Class 12.5 base course, and Class 9.5 surface course. All courses should be compacted to 95% prior to the next course being installed.

Class 9.5 Bituminous Concrete – 1.5” minimum compacted thickness
2.0” maximum compacted thickness
Class 12.5 Bituminous Concrete – 2.0” minimum compacted thickness
2.5” maximum compacted thickness

9.3.2 Mill and Inlay - Single gradation Class 9.5 bituminous concrete shall be used where grind/mill and inlay method is a condition of the Permit. This method is typically preceded by a temporary restoration, where the granular base is fully compacted or the concrete base has been fully restored with a temporary bituminous concrete patch.

The surface of the pavement shall be uniformly ground and removed to a minimum depth of 1.5 inches with a 3 inch keyway for subsequent pavement replacement. The grinding shall provide a 12 inch cutback into existing undisturbed pavement and shall encompass all disturbed pavement areas of the excavation. All work shall be done in straight lines. The existing pavement surface, all pavement layer interfaces and vertical faces shall have tack coat applied.

9.3.3 Concrete Roadway and Concrete Base - All excavations made within concrete roadways and roadways with concrete base shall be repaired with concrete in depths equal to the existing concrete, or a minimum of eight (8) inches. Concrete used for repairs shall conform to the requirements of RI Highway Standards for concrete roadway construction. 5/8”, 24” long epoxy coated #5 dowels shall be embedded into the existing concrete 12”, spaced every 18” on center. See City Roadway Restoration detail.

9.4 After backfilling and compaction, the Permittee shall either install a permanent patch (same day hot patching) or a temporary patch. If a temporary patch is installed, the Permittee may, subject to the provisions of this section, allow up to forty-five (45) days for settling before final patching.

9.4.1 Any temporary patch installed prior to November 1 in any year shall be replaced with a permanent patch no later than December 15 of that year. Temporary patches made between

September 1 and March 30 shall be maintained by the Permittee until a permanent patch can be installed, no later than June 15.

9.4.2 All excavation, backfilling and compaction work associated with temporary patches shall be performed in accordance with these Standards.

9.4.3 Temporary patches shall be made with Class 9.5 bituminous concrete to a minimum depth of 3 inches.

9.4.4 The Permittee shall be responsible to maintain temporary patches in a safe condition for all modes of travel until a permanent repair has been made. To ensure proper maintenance, the Permittee shall perform periodic inspection, at reasonable intervals of each temporary patch until it is replaced with a permanent patch.

9.4.5 All concrete sidewalk restorations shall take place between April 15 and November 15. If a permit is issued outside of this period, a hot bituminous asphalt patch shall be installed until the winter shutdown ends.

9.4.6 High performance bituminous cold patch is only permitted when hot mix asphalt is unavailable due to seasonal shutdowns.

9.5 Permanent patches on streets that are not Protected Streets shall be sealed with hot asphalt crack sealer.

9.6 Permanent patches on Protected Streets shall be the grind/mill and inlay method. The grinding/milling shall be a minimum of 10' in length (parallel to the curb) and shall extend from the curb to the nearest marked travel lane.

9.7 When the patch is less than two feet from the nearest curb, the permanent restoration shall extend to the curb.

9.8 If the length of the trench for any Permit exceeds the width of the roadway of that area, 1-1/2" asphalt repaving of the traffic lane impacted will be required. This may include cold planing of the existing pavement if it is deemed necessary by the permitting authority. Appropriate keyways shall be used where new pavement joins with existing pavement. Joints shall be treated with an infrared restoration process approved by the permitting authority for pavement less than 5 years old. Joints shall be treated with a joint sealant approved by the permitting authority for pavement greater than 5 years old.

9.9 The Permittee shall make every effort to limit excavations conducted under the aforementioned conditions.

9.10 All excavation, back fill, and compaction work associated with temporary and permanent patches shall be performed in accordance with these standards.

9.11 Completed pavement repairs shall not deviate more than 0.25 inches from the existing street surface. Deviation equal to or greater than 0.25 inches is cause for reconstruction of the restoration. Surface or joint cracking 0.125 (1/8) inches wide or greater shall be repaired utilizing a modified asphalt pavement sealant.

9.12 No less than thirty (30) days and no more than sixty (60) days from the completion of the permanent pavement repair, the Permittee shall inspect the excavation for settlements, cracking and other pavement defects. Any such excavation which has required repair shall then be reinspected no less than thirty (30) days and no more than sixty (60) days from the completion of the subsequent repair. The Permittee shall further inspect all excavations after a one-year time period and inform DPW Engineering of any failed restorations and the schedule for restoration.

9.13 Temporary and Permanent Restoration Failures

9.13.1 If a failure develops within the Permittee's excavation or the immediate vicinity of the excavation that is less than 5 years old, the Permittee will be responsible for repairing the failure.

9.13.2 Failures that are a threat to public safety (failure greater than two inches depth, shifted plate, etc.) shall be protected from traffic within one hour of notification, with crews mobilized for repair within four hours.

9.13.3 Failures that have settled a quarter inch to one inch shall be repaired within fifteen calendar days of notification

Failure to restore within the times stipulated may result in the DPW performing the repairs and invoicing the Contractor. Failure to pay for DPW performed work will result in revocation of License and refusal to issue permits.

9.14 When restoring roadways, special attention should be given to drainage structures. Inlet and apron stones (without frames and grates) shall be exposed to the full opening of the stone, despite the height of reveal prior to excavation. No inlets or drainage structures shall be paved over.

10.0 Striping and Traffic Detection Loop Restoration

10.1 Roadway striping and traffic detections loops are traffic control devices, which are used in part to apply and enforce traffic laws. It is imperative to restore striping and traffic detector loops as soon as possible.

10.2 Temporary Striping - Temporary waterborne paint, or adhesive roadway tape shall be installed prior to permanent restoration, and immediately after permanent restoration, until permanent striping is installed, matching the color and thickness of the existing striping.

Permanent Striping - Epoxy resin pavement markings shall be installed no later than 15 days after the final patch has been installed. The time after the installations allows the surface oils to dissipate from the roadway and ensure a satisfactory bond.

10.3 Traffic Detection Loops shall be restored within five (5) days of disruption. This may include restoration during the temporary patch, and restoration again after the permanent patch.

10.4 If the time from temporary patch to permanent patch is more than 30 days, with DPW permission, the permittee shall install, and re-apply, as needed, temporary waterborne pavement markings or temporary adhesive markings until the project is complete and prepared for epoxy resin pavement markings.

11.0 Sidewalks and Driveways

11.1 All work shall be performed in accordance the Americans with Disabilities Act (ADA), and RI Highway Standards, Section 904, and the Providence Standard Details. All sidewalk repairs greater than twenty five (25) feet in length shall conform to the ADA Standards (<https://www.access-board.gov/guidelines-and-standards/streets-sidewalks/public-rights-of-way/proposed-rights-of-way-guidelines>) and Providence Standard Details <https://www.providenceri.gov/wp-content/uploads/2017/04/Providence-DPW-Standard-Details.pdf>

11.2 Grass sidewalks and grass strips shall be restored fully, including a full stand of grass, free of weeds.

11.3 Driveways shall be so graded that no water shall enter the layout, pond or collect thereon, including the roadway and shall conform to the ADA Standards and Providence Standard Details

11.4 Sidewalks at intersections shall be restored to include an ADA compliant wheelchair ramp. See Providence Standard Details

12.0 Physical Alteration Permits

12.1 All work shall comply with all sections of these Standards.

12.2 Unless otherwise permitted, all sidewalk and driveway materials shall be Portland cement concrete.

12.3 All curbing shall be seven inch (7") width granite, Providence Standard. All curb cuts shall install two foot (2') radius granite returns.

12.4 Excess curbing shall be cleaned of debris and delivered to the Department of Public Works. Curbing shall be unloaded with a machine provided by the Sidewalk Contractor and not dumped.

12.4 New or modified curb cuts require review of the Traffic Engineering Department and the Engineering Department. Curb cuts shall comply with Article 14, Section 1407 of the Providence Zoning Ordinance.

13.0 Other Permits

13.1 Sewer permits are required when installing a new sewer service or repairing an existing sewer service. Sewer permits are issued to Rhode Island Master Plumbers or Rhode Island Underground Utility Contractors. When a new sewer service or repair is performed in the City Right-of-Way, a road opening permit is required. Sewer permits are issued by the Engineering Division.

13.2 Narragansett Bay Commission permits are required when establishing new sewer service to a property, adjusting Narragansett Bay Commission structures, or connecting directly to a Narragansett Bay Commission sewer main. Narragansett Bay Commission permits are required prior to issuing a City Sewer Permit for a new service connection.

13.3 Providence Traffic Engineering permits are required anytime work is performed in the Public Right-of-way, including but not limited to sidewalk closure, lane closure, road closure, detour or posting of emergency no parking signs. More information is provided on the following webpage, under "Traffic Engineering Forms" <http://www.providenceri.gov/public-works/forms/>

14.0 Clean-Up

14.1 The work area and the adjacent areas affected by the progress of the work shall be kept clean. All rubbish, surplus materials and unneeded construction equipment shall be removed. All damage to adjacent areas shall be repaired immediately so as to minimize inconvenience to the general public and the property owners.

14.2 All damage repairs shall be the sole responsibility of the contractor.

14.3 Material or debris from the contractor's operations which have washed into, flowed into, or been placed in water courses, ditches, gutters, sanitary sewers, drains, catch basins, or elsewhere, shall be removed entirely and properly disposed of during the progress of the work. The water courses, ditches, gutters, sanitary sewers, drains, catch basins, and other repositories of material or debris shall be kept in a clean and neat condition thereafter. The contractor shall restore or replace, at the direction of the City, any public or private property damaged by the work, equipment, or employees to a condition at least equal to the condition existing immediately prior to the beginning of operations. To this end, the contractor shall complete all required driveway, highway, front walk and landscaping work. Suitable materials, equipment and methods shall be used for such restoration. The contractor shall save harmless the City from any damage claims caused by the operations.



Director of Public Works

28 NOV 2017

Date



Approved Materials / Manufacturers

FOR USE IN THE PROVIDENCE WATER DISTRIBUTION SYSTEM

(As of **January 10, 2024**)

DUCTILE IRON PIPE

(Must Be Zinc Coated)

American DI Pipe Co.
McWane Ductile
U.S. Pipe & Foundry Co.

DUCTILE IRON FITTINGS

(Must Be Zinc Coated)

Tyler/Union Foundry Co.
U.S. Pipe & Foundry Co.
Star Pipe Products – US made only

VALVES

American
AVK
Clow Valve Co.
Kennedy Valve
M&H Valve Co.
Mueller Co.
U.S. Pipe & Foundry Co.
Red-White Valve Corp
Apollo Valve

VALVE AND SERVICE BOXES

A.Y. McDonald Manufacturing Co.
Bingham & Taylor
Mueller
The Ford Meter Box Co.
Tyler Union – US made only

PIPE COUPLINGS

Dresser, Inc.
ROMAC Industries, Inc.
Smith-Blair, Inc.
The Ford Meter Box Co.
Total Piping Solutions , Inc. (Hymax)

PLASTIC SERVICE COUPLINGS

The Harrington Corp (HARCO)

FIRE HYDRANTS

Kennedy Guardian Hydrant - K81D, by Kennedy Valve
(Must be “Hydra-Shield - Custodian” ready for installation in Providence only)

JOINT RESTRAINT FOR DUCTILE IRON PIPE- MECHANICAL

EBAA Iron Sales, Inc. MEGALUG MJ Retainer Gland
Series 1100 – MJ Gland
Series 1100SDB – Mid Span Restraint
Star National Products - “Star Tie-Anchor III Joint Restrainer”
Tyler Union – Series 1000 TUFGRIP MJ Retainer Gland-US made only

JOINT RESTRAINT FOR DUCTILE IRON PIPE- GASKETED

McWane SureStop 350 Gasket
U.S. Pipe & Foundry Co. - “Field Lok 350” Gasket
Griffin Pipe – “Talon RJ” Gasket

SERVICE BRASS/COPPER(must be “Lead Free”)

A.Y. McDonald Manufacturing Co.
Cambridge Lee Industries LLC
Mueller Co.
Red Hed Manufacturing
The Ford Meter Box Co.

NOTE: This list is subject to change without notice. Customers or contractors are responsible for contacting *Providence Water* to verify their selection of materials prior to starting any work. All valves and

Appendix G

EPA – American Iron and Steel (AIS) Requirements



UNITED STATES ENVIRONMENTAL PROTECTION AGENCY
WASHINGTON, D.C. 20460

APR 7 2017

OFFICE OF
WATER

MEMORANDUM

SUBJECT: Effective Until April 28, 2017. Application of American Iron and Steel Requirements for Drinking Water State Revolving Fund Projects for Fiscal Year 2017.

FROM: Anita Maria Thompkins, Director
Drinking Water Protection Division

A handwritten signature in black ink, appearing to read "Anita Maria Thompkins".

TO: Water Management Division Directors
Regions I-X

On December 10, 2016, the President signed Public Law 114-254, the "Further Continuing and Security Assistance Appropriations Act, 2017" (hereinafter referred to as the Continuing Resolution or CR) which provides fiscal year (FY) 2017 appropriations for continuing projects and activities of the Federal Government through April 28, 2017. This law extends funding for the Drinking Water State Revolving Fund for the time period of October 1, 2016 through April 28, 2017, with the same conditions that were made applicable by the language of the FY 2016 appropriation act, including the requirement for the use of American Iron and Steel (AIS) products in projects receiving financial assistance from the DWSRF.

We have received inquiries about the impact of recent legislation on the AIS provisions. On December 16, 2016, the President signed P.L. 114-322, the "Water Infrastructure Improvements for the Nation (WIIN) Act," which also included the DWSRF AIS requirement for FY 2017. However, the AIS language in the WIIN Act included an exemption for projects for which the engineering plans and specifications were approved by the State prior to the date of enactment. This exemption language was not included in the CR or the FY 2016 appropriation. The Government Accountability Office has asserted that continuing resolutions are meant to maintain the status quo. In addition, when two laws potentially conflict, the Supreme Court has strived to harmonize the laws to give maximum effect to both. Lastly, there is a presumption that Congress has not repealed a provision unless an intent to repeal is clear and manifest. Applying those principles here, there is no clear and manifest indication in the WIIN Act that Congress meant to repeal the provisions of the FY 2016 appropriation act (and subsequent CR). By its own terms, the WIIN Act exemption language states that the DWSRF AIS requirement imposed by "this paragraph" (*i.e.*, the Safe Drinking Water Act as amended by the WIIN Act) does not apply in the case of state-approved engineering plans and specifications. That language does not speak to DWSRF AIS requirements imposed by other laws. Therefore, the language of the FY 2016 appropriation act would continue to apply.

Therefore, all assistance agreements starting October 1, 2016 through April 28, 2017 must include the AIS requirement regardless of when the engineering plans and specifications were approved. If there is an additional CR, or if the Environmental Protection Agency (EPA) receives an FY 2017 appropriation,

the EPA will have to review that language to determine what, if any, effect might be given to the WIIN language.

If you have any questions, please contact Kiri Anderer (202-564-3134 or anderer.kirsten@epa.gov).

cc: Ronald Bergman, Associate Director, Drinking Water Protection Division
Felecia Fort, Associate Branch Chief, Infrastructure Branch, Drinking Water Protection Division
Kirsten Anderer, Environmental Engineer, DWSRF
Jorge Medrano, Environmental Engineer, DWSRF



UNITED STATES ENVIRONMENTAL PROTECTION AGENCY
WASHINGTON, D.C. 20460

MAR 20 2014

OFFICE OF WATER

MEMORANDUM

SUBJECT: Implementation of American Iron and Steel provisions of P.L. 113-76,
Consolidated Appropriations Act, 2014

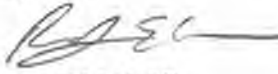
FROM: For Andrew D. Sawyers, Director 
Office of Wastewater Management (4201M)

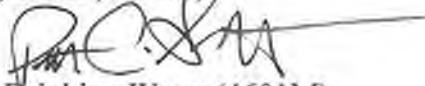
Peter C. Grevatt, Director 
Office of Ground Water and Drinking Water (4601M)

TO: Water Management Division Directors
Regions I - X

P.L. 113-76, Consolidated Appropriations Act, 2014 (Act), includes an “American Iron and Steel (AIS)” requirement in section 436 that requires Clean Water State Revolving Loan Fund (CWSRF) and Drinking Water State Revolving Loan Fund (DWSRF) assistance recipients to use iron and steel products that are produced in the United States for projects for the construction, alteration, maintenance, or repair of a public water system or treatment works if the project is funded through an assistance agreement executed beginning January 17, 2014 (enactment of the Act), through the end of Federal Fiscal Year 2014.

Section 436 also sets forth certain circumstances under which EPA may waive the AIS requirement. Furthermore, the Act specifically exempts projects where engineering plans and specifications were approved by a State agency prior to January 17, 2014.

The approach described below explains how EPA will implement the AIS requirement. The first section is in the form of questions and answers that address the types of projects that must comply with the AIS requirement, the types of products covered by the AIS requirement, and compliance. The second section is a step-by-step process for requesting waivers and the circumstances under which waivers may be granted.

Implementation

The Act states:

Sec. 436. (a)(1) None of the funds made available by a State water pollution control revolving fund as authorized by title VI of the Federal Water Pollution Control Act (33 U.S.C. 1381 et seq.) or made available by a drinking water treatment revolving loan fund as authorized by section 1452 of the Safe Drinking Water Act (42 U.S.C. 300j-12) shall be used for a project for the construction, alteration, maintenance, or repair of a public water system or treatment works unless all of the iron and steel products used in the project are produced in the United States.

(2) In this section, the term “iron and steel products” means the following products made primarily of iron or steel: lined or unlined pipes and fittings, manhole covers and other municipal castings, hydrants, tanks, flanges, pipe clamps and restraints, valves, structural steel, reinforced precast concrete, and construction materials.

(b) Subsection (a) shall not apply in any case or category of cases in which the Administrator of the Environmental Protection Agency (in this section referred to as the “Administrator”) finds that—

(1) applying subsection (a) would be inconsistent with the public interest;

(2) iron and steel products are not produced in the United States in sufficient and reasonably available quantities and of a satisfactory quality; or

(3) inclusion of iron and steel products produced in the United States will increase the cost of the overall project by more than 25 percent.

(c) If the Administrator receives a request for a waiver under this section, the Administrator shall make available to the public on an informal basis a copy of the request and information available to the Administrator concerning the request, and shall allow for informal public input on the request for at least 15 days prior to making a finding based on the request. The Administrator shall make the request and accompanying information available by electronic means, including on the official public Internet Web site of the Environmental Protection Agency.

(d) This section shall be applied in a manner consistent with United States obligations under international agreements.

(e) The Administrator may retain up to 0.25 percent of the funds appropriated in this Act for the Clean and Drinking Water State Revolving Funds for carrying out

the provisions described in subsection (a)(1) for management and oversight of the requirements of this section.

(f) This section does not apply with respect to a project if a State agency approves the engineering plans and specifications for the project, in that agency's capacity to approve such plans and specifications prior to a project requesting bids, prior to the date of the enactment of this Act.

The following questions and answers provide guidance for implementing and complying with the AIS requirements:

Project Coverage

1) What classes of projects are covered by the AIS requirement?

All treatment works projects funded by a CWSRF assistance agreement, and all public water system projects funded by a DWSRF assistance agreement, from the date of enactment through the end of Federal Fiscal Year 2014, are covered. The AIS requirements apply to the entirety of the project, no matter when construction begins or ends. Additionally, the AIS requirements apply to all parts of the project, no matter the source of funding.

2) Does the AIS requirement apply to nonpoint source projects or national estuary projects?

No. Congress did not include an AIS requirement for nonpoint source and national estuary projects unless the project can also be classified as a 'treatment works' as defined by section 212 of the Clean Water Act.

3) Are any projects for the construction, alteration, maintenance, or repair of a public water system or treatment works excluded from the AIS requirement?

Any project, whether a treatment works project or a public water system project, for which engineering plans and specifications were approved by the responsible state agency prior to January 17, 2014, is excluded from the AIS requirements.

4) What if the project does not have approved engineering plans and specifications but has signed an assistance agreement with a CWSRF or DWSRF program prior to January 17, 2014?

The AIS requirements do not apply to any project for which an assistance agreement was signed prior to January 17, 2014.

5) What if the project does not have approved engineering plans and specifications, but bids were advertised prior to January 17, 2014 and an assistance agreement was signed after January 17, 2014?

If the project does not require approved engineering plans and specifications, the bid advertisement date will count in lieu of the approval date for purposes of the exemption in section 436(f).

6) What if the assistance agreement that was signed prior to January 17, 2014, only funded a part of the overall project, where the remainder of the project will be funded later with another SRF loan?

If the original assistance agreement funded any construction of the project, the date of the original assistance agreement counts for purposes of the exemption. If the original assistance agreement was only for planning and design, the date of that assistance agreement will count for purposes of the exemption only if there is a written commitment or expectation on the part of the assistance recipient to fund the remainder of the project with SRF funds.

7) What if the assistance agreement that was signed prior to January 17, 2014, funded the first phase of a multi-phase project, where the remaining phases will be funded by SRF assistance in the future?

In such a case, the phases of the project will be considered a single project if all construction necessary to complete the building or work, regardless of the number of contracts or assistance agreements involved, are closely related in purpose, time and place. However, there are many situations in which major construction activities are clearly undertaken in phases that are distinct in purpose, time, or place. In the case of distinct phases, projects with engineering plans and specifications approval or assistance agreements signed prior to January 17, 2014 would be excluded from AIS requirements while those approved/signed on January 17, 2014, or later would be covered by the AIS requirements.

8) What if a project has split funding from a non-SRF source?

Many States intend to fund projects with “split” funding, from the SRF program and from State or other programs. Based on the Act language in section 436, which requires that American iron and steel products be used in any project for the construction, alteration, maintenance, or repair of a public water system or treatment works receiving SRF funding between and including January 17, 2014 and September 30, 2014, any project that is funded in whole or in part with such funds must comply with the AIS requirement. A “project” consists of all construction necessary to complete the building or work regardless of the number of contracts or assistance agreements involved so long as all contracts and assistance agreements awarded are closely related in purpose, time and place. This precludes the intentional splitting of SRF projects into separate and smaller contracts or assistance agreements to avoid AIS coverage on some portion of a larger

project, particularly where the activities are integrally and proximately related to the whole. However, there are many situations in which major construction activities are clearly undertaken in separate phases that are distinct in purpose, time, or place, in which case, separate contracts or assistance agreement for SRF and State or other funding would carry separate requirements.

9) What about refinancing?

If a project began construction, financed from a non-SRF source, prior to January 17, 2014, but is refinanced through an SRF assistance agreement executed on or after January 17, 2014 and prior to October 1, 2014, AIS requirements will apply to all construction that occurs on or after January 17, 2014, through completion of construction, unless, as is likely, engineering plans and specifications were approved by a responsible state agency prior to January 17, 2014. There is no retroactive application of the AIS requirements where a refinancing occurs for a project that has completed construction prior to January 17, 2014.

10) Do the AIS requirements apply to any other EPA programs, besides the SRF program, such as the Tribal Set-aside grants or grants to the Territories and DC?

No, the AIS requirement only applies to funds made available by a State water pollution control revolving fund as authorized by title VI of the Federal Water Pollution Control Act (33 U.S.C. 1381 et seq.) or made available by a drinking water treatment revolving loan fund as authorized by section 1452 of the Safe Drinking Water Act (42 U.S.C. 300j-12)

Covered Iron and Steel Products

11) What is an iron or steel product?

For purposes of the CWSRF and DWSRF projects that must comply with the AIS requirement, an iron or steel product is one of the following made primarily of iron or steel that is permanently incorporated into the public water system or treatment works:

- Lined or unlined pipes or fittings;
- Manhole Covers;
- Municipal Castings (defined in more detail below);
- Hydrants;
- Tanks;
- Flanges;
- Pipe clamps and restraints;
- Valves;
- Structural steel (defined in more detail below);
- Reinforced precast concrete; and
- Construction materials (defined in more detail below).

12) What does the term ‘primarily iron or steel’ mean?

‘Primarily iron or steel’ places constraints on the list of products above. For one of the listed products to be considered subject to the AIS requirements, it must be made of greater than 50% iron or steel, measured by cost. The cost should be based on the material costs.

13) Can you provide an example of how to perform a cost determination?

For example, the iron portion of a fire hydrant would likely be the bonnet, body and shoe, and the cost then would include the pouring and casting to create those components. The other material costs would include non-iron and steel internal workings of the fire hydrant (i.e., stem, coupling, valve, seals, etc). However, the assembly of the internal workings into the hydrant body would not be included in this cost calculation. If one of the listed products is not made primarily of iron or steel, United States (US) provenance is not required. An exception to this definition is reinforced precast concrete, which is addressed in a later question.

14) If a product is composed of more than 50% iron or steel, but is not listed in the above list of items, must the item be produced in the US? Alternatively, must the iron or steel in such a product be produced in the US?

The answer to both question is no. Only items on the above list must be produced in the US. Additionally, the iron or steel in a non-listed item can be sourced from outside the US.

15) What is the definition of steel?

Steel means an alloy that includes at least 50 percent iron, between .02 and 2 percent carbon, and may include other elements. Metallic elements such as chromium, nickel, molybdenum, manganese, and silicon may be added during the melting of steel for the purpose of enhancing properties such as corrosion resistance, hardness, or strength. The definition of steel covers carbon steel, alloy steel, stainless steel, tool steel and other specialty steels.

16) What does ‘produced in the United States’ mean?

Production in the United States of the iron or steel products used in the project requires that all manufacturing processes, including application of coatings, must take place in the United States, with the exception of metallurgical processes involving refinement of steel additives. All manufacturing processes includes processes such as melting, refining, forming, rolling, drawing, finishing, fabricating and coating. Further, if a domestic iron and steel product is taken out of the US for any part of the manufacturing process, it becomes foreign source material. However, raw materials such as iron ore, limestone and iron and steel scrap are not covered by the AIS requirement, and the

material(s), if any, being applied as a coating are similarly not covered. Non-iron or steel components of an iron and steel product may come from non-US sources. For example, for products such as valves and hydrants, the individual non-iron and steel components do not have to be of domestic origin.

17) Are the raw materials used in the production of iron or steel required to come from US sources?

No. Raw materials, such as iron ore, limestone, scrap iron, and scrap steel, can come from non-US sources.

18) If an above listed item is primarily made of iron or steel, but is only at the construction site temporarily, must such an item be produced in the US?

No. Only the above listed products made primarily of iron or steel, permanently incorporated into the project must be produced in the US. For example trench boxes, scaffolding or equipment, which are removed from the project site upon completion of the project, are not required to be made of U.S. Iron or Steel.

19) What is the definition of ‘municipal castings’?

Municipal castings are cast iron or steel infrastructure products that are melted and cast. They typically provide access, protection, or housing for components incorporated into utility owned drinking water, storm water, wastewater, and surface infrastructure. They are typically made of grey or ductile iron, or steel. Examples of municipal castings are:

- Access Hatches;
- Ballast Screen;
- Benches (Iron or Steel);
- Bollards;
- Cast Bases;
- Cast Iron Hinged Hatches, Square and Rectangular;
- Cast Iron Riser Rings;
- Catch Basin Inlet;
- Cleanout/Monument Boxes;
- Construction Covers and Frames;
- Curb and Corner Guards;
- Curb Openings;
- Detectable Warning Plates;
- Downspout Shoes (Boot, Inlet);
- Drainage Grates, Frames and Curb Inlets;
- Inlets;
- Junction Boxes;
- Lampposts;
- Manhole Covers, Rings and Frames, Risers;

Meter Boxes;
Service Boxes;
Steel Hinged Hatches, Square and Rectangular;
Steel Riser Rings;
Trash receptacles;
Tree Grates;
Tree Guards;
Trench Grates; and
Valve Boxes, Covers and Risers.

20) What is ‘structural steel’?

Structural steel is rolled flanged shapes, having at least one dimension of their cross-section three inches or greater, which are used in the construction of bridges, buildings, ships, railroad rolling stock, and for numerous other constructional purposes. Such shapes are designated as wide-flange shapes, standard I-beams, channels, angles, tees and zees. Other shapes include H-piles, sheet piling, tie plates, cross ties, and those for other special purposes.

21) What is a ‘construction material’ for purposes of the AIS requirement?

Construction materials are those articles, materials, or supplies made primarily of iron and steel, that are permanently incorporated into the project, not including mechanical and/or electrical components, equipment and systems. Some of these products may overlap with what is also considered “structural steel”. This includes, but is not limited to, the following products: wire rod, bar, angles, concrete reinforcing bar, wire, wire cloth, wire rope and cables, tubing, framing, joists, trusses, fasteners (i.e., nuts and bolts), welding rods, decking, grating, railings, stairs, access ramps, fire escapes, ladders, wall panels, dome structures, roofing, ductwork, surface drains, cable hanging systems, manhole steps, fencing and fence tubing, guardrails, doors, and stationary screens.

22) What is not considered a ‘construction material’ for purposes of the AIS requirement?

Mechanical and electrical components, equipment and systems are not considered construction materials. Mechanical equipment is typically that which has motorized parts and/or is powered by a motor. Electrical equipment is typically any machine powered by electricity and includes components that are part of the electrical distribution system.

The following examples (including their appurtenances necessary for their intended use and operation) are NOT considered construction materials: pumps, motors, gear reducers, drives (including variable frequency drives (VFDs)), electric/pneumatic/manual accessories used to operate valves (such as electric valve actuators), mixers, gates, motorized screens (such as traveling screens), blowers/aeration equipment, compressors, meters, sensors, controls and switches, supervisory control and

data acquisition (SCADA), membrane bioreactor systems, membrane filtration systems, filters, clarifiers and clarifier mechanisms, rakes, grinders, disinfection systems, presses (including belt presses), conveyors, cranes, HVAC (excluding ductwork), water heaters, heat exchangers, generators, cabinetry and housings (such as electrical boxes/enclosures), lighting fixtures, electrical conduit, emergency life systems, metal office furniture, shelving, laboratory equipment, analytical instrumentation, and dewatering equipment.

23) If the iron or steel is produced in the US, may other steps in the manufacturing process take place outside of the US, such as assembly?

No. Production in the US of the iron or steel used in a listed product requires that all manufacturing processes must take place in the United States, except metallurgical processes involving refinement of steel additives.

24) What processes must occur in the US to be compliant with the AIS requirement for reinforced precast concrete?

While reinforced precast concrete may not be at least 50% iron or steel, in this particular case, the reinforcing bar and wire must be produced in the US and meet the same standards as for any other iron or steel product. Additionally, the casting of the concrete product must take place in the US. The cement and other raw materials used in concrete production are not required to be of domestic origin.

If the reinforced concrete is cast at the construction site, the reinforcing bar and wire are considered to be a construction material and must be produced in the US.

Compliance

25) How should an assistance recipient document compliance with the AIS requirement?

In order to ensure compliance with the AIS requirement, specific AIS contract language must be included in each contract, starting with the assistance agreement, all the way down to the purchase agreements. Sample language for assistance agreements and contracts can be found in Appendix 3 and 4.

EPA recommends the use of a step certification process, similar to one used by the Federal Highway Administration. The step certification process is a method to ensure that producers adhere to the AIS requirement and assistance recipients can verify that products comply with the AIS requirement. The process also establishes accountability and better enables States to take enforcement actions against violators.

Step certification creates a paper trail which documents the location of the manufacturing process involved with the production of steel and iron materials. A step certification is a process under which each handler (supplier, fabricator, manufacturer,

processor, etc) of the iron and steel products certifies that their step in the process was domestically performed. Each time a step in the manufacturing process takes place, the manufacturer delivers its work along with a certification of its origin. A certification can be quite simple. Typically, it includes the name of the manufacturer, the location of the manufacturing facility where the product or process took place (not its headquarters), a description of the product or item being delivered, and a signature by a manufacturer's responsible party. Attached, as Appendix 5, are sample certifications. These certifications should be collected and maintained by assistance recipients.

Alternatively, the final manufacturer that delivers the iron or steel product to the worksite, vendor, or contractor, may provide a certification asserting that all manufacturing processes occurred in the US. While this type of certification may be acceptable, it may not provide the same degree of assurance. Additional documentation may be needed if the certification is lacking important information. Step certification is the best practice.

26) How should a State ensure assistance recipients are complying with the AIS requirement?

In order to ensure compliance with the AIS requirement, States SRF programs must include specific AIS contract language in the assistance agreement. Sample language for assistance agreements can be found in Appendix 3.

States should also, as a best practice, conduct site visits of projects during construction and review documentation demonstrating proof of compliance which the assistance recipient has gathered.

27) What happens if a State or EPA finds a non-compliant iron and/or steel product permanently incorporated in the project?

If a potentially non-compliant product is identified, the State should notify the assistance recipient of the apparent unauthorized use of the non-domestic component, including a proposed corrective action, and should be given the opportunity to reply. If unauthorized use is confirmed, the State can take one or more of the following actions: request a waiver where appropriate; require the removal of the non-domestic item; or withhold payment for all or part of the project. Only EPA can issue waivers to authorize the use of a non-domestic item. EPA may use remedies available to it under the Clean Water Act, the Safe Drinking Water Act, and 40 CFR part 31 grant regulations, in the event of a violation of a grant term and condition.

It is recommended that the State work collaboratively with EPA to determine the appropriate corrective action, especially in cases where the State is the one who identifies the item in noncompliance or there is a disagreement with the assistance recipient.

If fraud, waste, abuse, or any violation of the law is suspected, the Office of Inspector General (OIG) should be contacted immediately. The OIG can be reached at 1-

888-546-8740 or OIG_Hotline@epa.gov. More information can be found at this website: <http://www.epa.gov/oig/hotline.htm>.

28) How do international trade agreements affect the implementation of the AIS requirements?

The AIS provision applies in a manner consistent with United States obligations under international agreements. Typically, these obligations only apply to direct procurement by the entities that are signatories to such agreements. In general, SRF assistance recipients are not signatories to such agreements, so these agreements have no impact on this AIS provision. In the few instances where such an agreement applies to a municipality, that municipality is under the obligation to determine its applicability and requirements and document the actions taken to comply for the State.

Waiver Process

The statute permits EPA to issue waivers for a case or category of cases where EPA finds (1) that applying these requirements would be inconsistent with the public interest; (2) iron and steel products are not produced in the US in sufficient and reasonably available quantities and of a satisfactory quality; or (3) inclusion of iron and steel products produced in the US will increase the cost of the overall project by more than 25 percent.

In order to implement the AIS requirements, EPA has developed an approach to allow for effective and efficient implementation of the waiver process to allow projects to proceed in a timely manner. The framework described below will allow States, on behalf of the assistance recipients, to apply for waivers of the AIS requirement directly to EPA Headquarters. Only waiver requests received from states will be considered. Pursuant to the Act, EPA has the responsibility to make findings as to the issuance of waivers to the AIS requirements.

Definitions

The following terms are critical to the interpretation and implementation of the AIS requirements and apply to the process described in this memorandum:

Reasonably Available Quantity: The quantity of iron or steel products is available or will be available at the time needed and place needed, and in the proper form or specification as specified in the project plans and design.

Satisfactory Quality: The quality of iron or steel products, as specified in the project plans and designs.

Assistance Recipient: A borrower or grantee that receives funding from a State CWSRF or DWSRF program.

Step-By-Step Waiver Process

Application by Assistance Recipient

Each local entity that receives SRF water infrastructure financial assistance is required by section 436 of the Act to use American made iron and steel products in the construction of its project. However, the recipient may request a waiver. Until a waiver is granted by EPA, the AIS requirement stands, except as noted above with respect to municipalities covered by international agreements.

The waiver process begins with the SRF assistance recipient. In order to fulfill the AIS requirement, the assistance recipient must in good faith design the project (where applicable) and solicit bids for construction with American made iron and steel products. It is essential that the assistance recipient include the AIS terms in any request for proposals or solicitations for bids, and in all contracts (see Appendix 3 for sample construction contract language). The assistance recipient may receive a waiver at any point before, during, or after the bid process, if one or more of three conditions is met:

1. Applying the American Iron and Steel requirements of the Act would be inconsistent with the public interest;
2. Iron and steel products are not produced in the United States in sufficient and reasonably available quantities and of a satisfactory quality; or
3. Inclusion of iron and steel products produced in the United States will increase the cost of the overall project by more than 25 percent.

Proper and sufficient documentation must be provided by the assistance recipient. A checklist detailing the types of information required for a waiver to be processed is attached as Appendix 1.

Additionally, it is strongly encouraged that assistance recipients hold pre-bid conferences with potential bidders. A pre-bid conference can help to identify iron and steel products needed to complete the project as described in the plans and specifications that may not be available from domestic sources. It may also identify the need to seek a waiver prior to bid, and can help inform the recipient on compliance options.

In order to apply for a project waiver, the assistance recipient should email the request in the form of a Word document (.doc) to the State SRF program. It is strongly recommended that the State designate a single person for all AIS communications. The State SRF designee will review the application for the waiver and determine whether the necessary information has been included. Once the waiver application is complete, the State designee will forward the application to either of two email addresses. For CWSRF waiver requests, please send the application to: cwsrfwaiver@epa.gov. For DWSRF waiver requests, please send the application to: dwsrfwaiver@epa.gov.

Evaluation by EPA

After receiving an application for waiver of the AIS requirements, EPA Headquarters will publish the request on its website for 15 days and receive informal comment. EPA Headquarters will then use the checklist in Appendix 2 to determine whether the application properly and adequately documents and justifies the statutory basis cited for the waiver – that it is quantitatively and qualitatively sufficient – and to determine whether or not to grant the waiver.

In the event that EPA finds that adequate documentation and justification has been submitted, the Administrator may grant a waiver to the assistance recipient. EPA will notify the State designee that a waiver request has been approved or denied as soon as such a decision has been made. Granting such a waiver is a three-step process:

1. Posting – After receiving an application for a waiver, EPA is required to publish the application and all material submitted with the application on EPA’s website for 15 days. During that period, the public will have the opportunity to review the request and provide informal comment to EPA. The website can be found at: http://water.epa.gov/grants_funding/aisrequirement.cfm
2. Evaluation – After receiving an application for waiver of the AIS requirements, EPA Headquarters will use the checklist in Appendix 2 to determine whether the application properly and adequately documents and justifies the statutory basis cited for the waiver – that it is quantitatively and qualitatively sufficient – and to determine whether or not to grant the waiver.
3. Signature of waiver approval by the Administrator or another agency official with delegated authority – As soon as the waiver is signed and dated, EPA will notify the State SRF program, and post the signed waiver on our website. The assistance recipient should keep a copy of the signed waiver in its project files.

Public Interest Waivers

EPA has the authority to issue public interest waivers. Evaluation of a public interest waiver request may be more complicated than that of other waiver requests so they may take more time than other waiver requests for a decision to be made. An example of a public interest waiver that might be issued could be for a community that has standardized on a particular type or manufacturer of a valve because of its performance to meet their specifications. Switching to an alternative valve may require staff to be trained on the new equipment and additional spare parts would need to be purchased and stocked, existing valves may need to be unnecessarily replaced, and portions of the system may need to be redesigned. Therefore, requiring the community to install an alternative valve would be inconsistent with public interest.

EPA also has the authority to issue a public interest waiver that covers categories of products that might apply to all projects.

EPA reserves the right to issue national waivers that may apply to particular classes of assistance recipients, particular classes of projects, or particular categories of iron or steel products. EPA may develop national or (US geographic) regional categorical waivers through the identification of similar circumstances in the detailed justifications presented to EPA in a waiver request or requests. EPA may issue a national waiver based on policy decisions regarding the public's interest or a determination that a particular item is not produced domestically in reasonably available quantities or of a sufficient quality. In such cases, EPA may determine it is necessary to issue a national waiver.

If you have any questions concerning the contents of this memorandum, you may contact us, or have your staff contact Jordan Dorfman, Attorney-Advisor, State Revolving Fund Branch, Municipal Support Division, at dorfman.jordan@epa.gov or (202) 564-0614 or Kiri Anderer, Environmental Engineer, Infrastructure Branch, Drinking Water Protection Division, at anderer.kirsten@epa.gov or (202) 564-3134.

Attachments

Appendix 1: Information Checklist for Waiver Request

The purpose of this checklist is to help ensure that all appropriate and necessary information is submitted to EPA. EPA recommends that States review this checklist carefully and provide all appropriate information to EPA. This checklist is for informational purposes only and does not need to be included as part of a waiver application.

Items	✓	Notes
<p>General</p> <ul style="list-style-type: none"> • Waiver request includes the following information: <ul style="list-style-type: none"> — Description of the foreign and domestic construction materials — Unit of measure — Quantity — Price — Time of delivery or availability — Location of the construction project — Name and address of the proposed supplier — A detailed justification for the use of foreign construction materials • Waiver request was submitted according to the instructions in the memorandum • Assistance recipient made a good faith effort to solicit bids for domestic iron and steel products, as demonstrated by language in requests for proposals, contracts, and communications with the prime contractor 		
<p>Cost Waiver Requests</p> <ul style="list-style-type: none"> • Waiver request includes the following information: <ul style="list-style-type: none"> — Comparison of overall cost of project with domestic iron and steel products to overall cost of project with foreign iron and steel products — Relevant excerpts from the bid documents used by the contractors to complete the comparison — Supporting documentation indicating that the contractor made a reasonable survey of the market, such as a description of the process for identifying suppliers and a list of contacted suppliers 		
<p>Availability Waiver Requests</p> <ul style="list-style-type: none"> • Waiver request includes the following supporting documentation necessary to demonstrate the availability, quantity, and/or quality of the materials for which the waiver is requested: <ul style="list-style-type: none"> — Supplier information or pricing information from a reasonable number of domestic suppliers indicating availability/delivery date for construction materials — Documentation of the assistance recipient's efforts to find available domestic sources, such as a description of the process for identifying suppliers and a list of contacted suppliers. — Project schedule — Relevant excerpts from project plans, specifications, and permits indicating the required quantity and quality of construction materials • Waiver request includes a statement from the prime contractor and/or supplier confirming the non-availability of the domestic construction materials for which the waiver is sought • Has the State received other waiver requests for the materials described in this waiver request, for comparable projects? 		

Appendix 2: HQ Review Checklist for Waiver Request

Instructions: To be completed by EPA. Review all waiver requests using the questions in the checklist, and mark the appropriate box as Yes, No or N/A. Marks that fall inside the shaded boxes may be grounds for denying the waiver. If none of your review markings fall into a shaded box, the waiver is eligible for approval if it indicates that one or more of the following conditions applies to the domestic product for which the waiver is sought:

1. The iron and/or steel products are not produced in the United States in sufficient and reasonably available quantities and of a satisfactory quality.
2. The inclusion of iron and/or steel products produced in the United States will increase the cost of the overall project by more than 25 percent.

Review Items	Yes	No	N/A	Comments
Cost Waiver Requests <ul style="list-style-type: none"> • Does the waiver request include the following information? <ul style="list-style-type: none"> — Comparison of overall cost of project with domestic iron and steel products to overall cost of project with foreign iron and steel products — Relevant excerpts from the bid documents used by the contractors to complete the comparison — A sufficient number of bid documents or pricing information from domestic sources to constitute a reasonable survey of the market • Does the Total Domestic Project exceed the Total Foreign Project Cost by more than 25%? 				
Availability Waiver Requests <ul style="list-style-type: none"> • Does the waiver request include supporting documentation sufficient to show the availability, quantity, and/or quality of the iron and/or steel product for which the waiver is requested? <ul style="list-style-type: none"> — Supplier information or other documentation indicating availability/delivery date for materials — Project schedule — Relevant excerpts from project plans, specifications, and permits indicating the required quantity and quality of materials • Does supporting documentation provide sufficient evidence that the contractors made a reasonable effort to locate domestic suppliers of materials, such as a description of the process for identifying suppliers and a list of contacted suppliers? • Based on the materials delivery/availability date indicated in the supporting documentation, will the materials be unavailable when they are needed according to the project schedule? (By item, list schedule date and domestic delivery quote date or other relevant information) • Is EPA aware of any other evidence indicating the non-availability of the materials for which the waiver is requested? Examples include: <ul style="list-style-type: none"> — Multiple waiver requests for the materials described in this waiver request, for comparable projects in the same State — Multiple waiver requests for the materials described in this waiver request, for comparable projects in other States — Correspondence with construction trade associations indicating the non-availability of the materials • Are the available domestic materials indicated in the bid documents of inadequate quality compared those required by the project plans, specifications, and/or permits? 				

Appendix 3: Example Loan Agreement Language

ALL ASSISTANCE AGREEMENT MUST HAVE A CLAUSE REQUIRING COMPLIANCE WITH THE AIS REQUIREMENT. THIS IS AN EXAMPLE OF WHAT COULD BE INCLUDED IN SRF ASSISTANCE AGREEMENTS. EPA MAKES NO CLAIMS REGARDING THE LEGALITY OF THIS CLAUSE WITH RESPECT TO STATE LAW:

Comply with all federal requirements applicable to the Loan (including those imposed by the 2014 Appropriations Act and related SRF Policy Guidelines) which the Participant understands includes, among other, requirements that all of the iron and steel products used in the Project are to be produced in the United States (“American Iron and Steel Requirement”) unless (i) the Participant has requested and obtained a waiver from the Agency pertaining to the Project or (ii) the Finance Authority has otherwise advised the Participant in writing that the American Iron and Steel Requirement is not applicable to the Project.

Comply with all record keeping and reporting requirements under the Clean Water Act/Safe Drinking Water Act, including any reports required by a Federal agency or the Finance Authority such as performance indicators of program deliverables, information on costs and project progress. The Participant understands that (i) each contract and subcontract related to the Project is subject to audit by appropriate federal and state entities and (ii) failure to comply with the Clean Water Act/Safe Drinking Water Act and this Agreement may be a default hereunder that results in a repayment of the Loan in advance of the maturity of the Bonds and/or other remedial actions.

Appendix 4: Sample Construction Contract Language

ALL CONTRACTS MUST HAVE A CLAUSE REQUIRING COMPLIANCE WITH THE AIS REQUIREMENT. THIS IS AN EXAMPLE OF WHAT COULD BE INCLUDED IN ALL CONTRACTS IN PROJECTS THAT USE SRF FUNDS. EPA MAKES NO CLAIMS REGARDING THE LEGALITY OF THIS CLAUSE WITH RESPECT TO STATE OR LOCAL LAW:

The Contractor acknowledges to and for the benefit of the City of _____ (“Purchaser”) and the _____ (the “State”) that it understands the goods and services under this Agreement are being funded with monies made available by the Clean Water State Revolving Fund and/or Drinking Water State Revolving Fund that have statutory requirements commonly known as “American Iron and Steel;” that requires all of the iron and steel products used in the project to be produced in the United States (“American Iron and Steel Requirement”) including iron and steel products provided by the Contractor pursuant to this Agreement. The Contractor hereby represents and warrants to and for the benefit of the Purchaser and the State that (a) the Contractor has reviewed and understands the American Iron and Steel Requirement, (b) all of the iron and steel products used in the project will be and/or have been produced in the United States in a manner that complies with the American Iron and Steel Requirement, unless a waiver of the requirement is approved, and (c) the Contractor will provide any further verified information, certification or assurance of compliance with this paragraph, or information necessary to support a waiver of the American Iron and Steel Requirement, as may be requested by the Purchaser or the State. Notwithstanding any other provision of this Agreement, any failure to comply with this paragraph by the Contractor shall permit the Purchaser or State to recover as damages against the Contractor any loss, expense, or cost (including without limitation attorney’s fees) incurred by the Purchaser or State resulting from any such failure (including without limitation any impairment or loss of funding, whether in whole or in part, from the State or any damages owed to the State by the Purchaser). While the Contractor has no direct contractual privity with the State, as a lender to the Purchaser for the funding of its project, the Purchaser and the Contractor agree that the State is a third-party beneficiary and neither this paragraph (nor any other provision of this Agreement necessary to give this paragraph force or effect) shall be amended or waived without the prior written consent of the State.

Appendix 5: Sample Certifications

The following information is provided as a sample letter of **step** certification for AIS compliance. Documentation must be provided on company letterhead.

Date

Company Name

Company Address

City, State Zip

Subject: American Iron and Steel Step Certification for Project (XXXXXXXXXX)

I, (company representative), certify that the (melting, bending, coating, galvanizing, cutting, etc.) process for (manufacturing or fabricating) the following products and/or materials shipped or provided for the subject project is in full compliance with the American Iron and Steel requirement as mandated in EPA's State Revolving Fund Programs.

Item, Products and/or Materials:

1. XXXX
2. XXXX
3. XXXX

Such process took place at the following location:

If any of the above compliance statements change while providing material to this project we will immediately notify the prime contractor and the engineer.

Signed by company representative

The following information is provided as a sample letter of certification for AIS compliance. Documentation must be provided on company letterhead.

Date

Company Name

Company Address

City, State Zip

Subject: American Iron and Steel Certification for Project (XXXXXXXXXXXX)

I, (company representative), certify that the following products and/or materials shipped/provided to the subject project are in full compliance with the American Iron and Steel requirement as mandated in EPA's State Revolving Fund Programs.

Item, Products and/or Materials:

1. XXXX
2. XXXX
3. XXXX

Such process took place at the following location:

If any of the above compliance statements change while providing material to this project we will immediately notify the prime contractor and the engineer.

Signed by company representative

May 30, 2014

American Iron & Steel (AIS) Requirement of the Consolidated Appropriations Act of 2014 (Public Law 113-76) Q&A Part 1: Valves and Hydrants

Q1: Does the AIS requirement of the Consolidated Appropriations Act of 2014 require minor, miscellaneous components within a covered valve or hydrant, such as nuts, bolts and washers, to be made in the U.S.?

A1: The definition of "iron and steel products" that must either be domestically produced or subject to a waiver in order to comply with the AIS requirement of the Consolidated Appropriations Act of 2014 includes valves and hydrants. Unlike many other of the "iron and steel products" that are listed in the definition, valves and hydrants are typically precision mechanical products with multiple fitted, operating parts and connections. Valves and hydrants, unlike most of the other listed products, contain other minor components, such as small washers, nuts, and bolts that are of unknown origin but are added to the valve or hydrant during the manufacturing process. For purposes of the 2014 AIS requirement, EPA considers only the significant iron and steel components of a covered valve or hydrant – the body, bonnet, shoe, stem, and wedge/disc/gate/ball – to be within the definition of "iron and steel products" that must either be made domestically, or otherwise must comply with the AIS requirement. The minor components represent a very small percentage of the iron and steel in the hydrants and valves that are defined as "iron and steel products." These minor components, which EPA has learned through our research are currently difficult to find domestically in sufficient quantity, such as minor nuts, bolts, and washers, are not required to be of U.S. origin.

Q2: Do the actuators/control systems attached to valves have to comply with the AIS requirement, or just the valve itself?

A2: The AIS requirement of the Consolidated Appropriations Act of 2014 includes valves in its definition of "iron and steel products" that recipients must make certain are either domestically made or subject to a waiver in order to comply with the AIS requirement. Actuators and control systems are not included in the definition. Only the valve itself is required to be either domestically produced or subject to a waiver in order to be compliant with the AIS requirement. Absent a waiver, EPA considers valves and hydrants to be domestically produced if the significant iron and steel components of a covered valve or hydrant – the body, bonnet, shoe, stem, and wedge/disc/gate/ball – if made of iron or steel, is produced in the U.S. See Q1 above for a discussion about minor components. The valves and actuators, while often purchased and shipped together, are two unique products that are manufactured separately and typically attached together during the final step of the process. Valves are included in the definition of "iron and steel products" in the AIS requirement. Actuators, whether manual, electric, hydraulic or pneumatic, are not listed as an "iron and steel product" under the AIS requirement of the Consolidated Appropriations Act of 2014, nor are they considered construction materials. Therefore, they do not need to be domestically produced in the U.S. in order to comply with the requirement.

Q3: Are electric powered motor operated valves excluded based on the valve being motorized equipment (i.e. electrical equipment)?

A3: No, electric powered motor operated valves are not excluded based on the valve being motorized equipment. The actuator, a motor that controls the valve, is considered a separate product, which is not

May 30, 2014

listed as an “iron and steel product” under the AIS requirement of the Consolidated Appropriations Act of 2014, nor is it considered a construction material. Therefore, the actuator does not need to be domestically produced in the U.S. in order to comply with the requirement. See Q2 for further clarification.

Q4: Based on EPA’s AIS guidance dated March 20, 2014, gates are not considered construction materials and therefore do not have to be produced in the U.S. Does that include gate valves?

A4: No, valves are specifically listed in the Consolidated Appropriations Act of 2014 as an “iron and steel product” and therefore, absent a waiver, must be produced in the U.S. to be in compliance with the requirement if they are “primarily” iron and steel. Gates as referenced in the EPA March 20, 2014 guidance refer only to common sluice and slide gates, and not to gate valves.

September 10, 2014

**American Iron & Steel (AIS) Requirement of the Consolidated Appropriations Act of 2014
(Public Law 113-76)**

Q&A Part 2

PRODUCT QUESTIONS

1. Q: Do all fasteners qualify for de minimis exemption?

A: No. There is no broad exemption for fasteners from the American Iron and Steel (AIS) requirements. Significant fasteners used in SRF projects are not subject to the de minimis waiver for projects and must comply with the AIS requirements. Significant fasteners include fasteners produced to industry standards (e.g., ASTM standards) and/or project specifications, special ordered or those of high value. When bulk purchase of unknown-origin fasteners that are of incidental use and small value are used on a project, they may fall under the national de minimis waiver for projects. The list of potential items could be varied, such as big-box/hardware-store-variety screws, nails, and staples. The key characteristics of the items that may qualify for the de minimis waiver would be items that are incidental to the project purpose (such as drywall screws) and not significant in value or purpose (such as common nails or brads). See the following: http://water.epa.gov/grants_funding/upload/Deminimis-Waiver-04-15-14.pdf.

EPA also clarifies that minor components of two listed products – valves and hydrants -- may not need to meet the AIS requirements if the minor components comprise a very small quantity of minor, low-cost fasteners that are of unknown origin. See EPA's questions and answers on the subject at the following: http://water.epa.gov/grants_funding/upload/AIS-QandA-Part-1-Valves-and-Hydrants-final.pdf.

2. Q: Does PCCP pipe have to be domestically produced?

A: Yes. Pre-stressed concrete cylinder pipe (PCCP) or other similar concrete cylinder pipes would be comparable to pre-cast concrete which is specifically listed in the Consolidated Appropriations Act of 2014 as a product subject to the AIS requirement.

3. Q: If the iron or steel is made from recycled metals will the vendor/supplier have to provide a certification document certifying that the recycled metals are domestically produced?

A: No. Recycled source materials used in the production of iron and steel products do not have to come from the U.S. Iron or steel scrap, for instance, are considered raw materials that may come from anywhere. While certification is not required for the raw material, EPA does recommend that additional final processing of iron and steel be certified to have occurred in the U.S.

4. Q: Do tanks used for filtration systems, if delivered to the construction site separately and then filled with filtration media onsite, have to be domestically produced?

A: No. Tanks that are specifically designed to be filters, or as parts of a filtration system, do not have to be domestically produced because these parts are no longer simply tanks, even if the filter media has not been installed and will be installed at the project site, as is customary to do for shipping purposes. These parts have only one purpose which is to be housing for filters and cannot be used in another fashion.

5. Q: Can a recipient use non-domestic flanged pipe?

A: No. While the Consolidated Appropriations Act of 2014 does not specifically mention flanged pipe, since it does mention both pipe and flanges, both products would need to be domestically produced. Therefore, flanged pipe would also need to be domestically produced.

6. Q: Can a recipient use non-domestic couplings, expansion joints, and other similar pipe connectors?

A: No. These products would be considered specialty fittings, due to their additional functionality, but still categorized under the larger “fitting” categorization. Fittings are defined as a material that joins pipes together or connects to a pipe (AWWA, The Drinking Water Dictionary, 2000). Therefore, these products must comply with the AIS requirements and be produced domestically.

7. Q: Can a recipient use non-domestic service saddles and tapping sleeves?

A: No. These products are necessary for pipe repair, to tap a water main, or to install a service or house connection. Therefore, they are included under the larger “pipe restraint” category which is a specifically identified product subject to the domestic preference in the Consolidated Appropriations Act of 2014.

8. Q: The AIS guidance does not appear to cover reused items (i.e., existing pipe fittings, used storage tanks, reusing existing valves). How should reused items be addressed?

A: The AIS guidance does not address reuse of items. Reuse of items that would otherwise be covered by AIS is acceptable provided that the item(s) was originally purchased prior to January 17, 2014, the reused item(s) is not substantially altered from original form/function, and any restoration work that may be required does not include the replacement or addition of foreign iron or steel replacement parts. EPA recommends keeping a log of these reused items by including them on the assistance recipient’s de minimis list, and stating therein that these items are reused products. The donation of new items (such as a manufacturer waiving cost for certain delivered items because of concerns regarding the origin of a new product) is not, however, considered reuse.

9. Q: What does “time needed” mean in the AIS guidance, in reference to the definition of “Reasonably Available Quantity”?

September 10, 2014

A: For considering whether a product would meet reasonably available quantity, “time needed” is based on the construction schedule. If the item is delayed and there is substantial impact on the overall construction schedule, this would not be according to the “time needed.”

10. Q: If a product is not specifically included on the list of AIS covered products, must it comply with AIS?

A: Possibly. The AIS requirements include a list of specifically covered products, one of which is construction materials, a broad category of potential products. For construction materials, EPA’s AIS guidance includes a set of example items that it considers construction materials composed primarily of iron and steel and covered by the Act. This example list in the guidance is not an all-inclusive list of potential construction materials. However, the guidance also includes a list of items that EPA specifically does not consider construction materials, generally those of electrical or complex-mechanical nature. If a product is similar to the ones in the non-construction material list (and it is also not specifically listed by the Act), it is not a construction material. For all other items specifically included in the Act, coverage is generally self-evident.

11. Q: If a listed iron and steel product is used as a part for an assembled product that is non-domestic, do the AIS requirements apply?

A: AIS requirements only apply to the final product as delivered to the work site and incorporated into the project. Other assemblies, such as a pumping assembly or a reverse osmosis package plant, are distinct products not listed and do not need to be made in the U.S. or composed of all U.S. parts. Therefore, for the case of a non-covered product used in a larger non-domestic assembly, the components, even if specifically listed in the Consolidated Appropriations Act, do not have to be domestically produced.

12. Q: Is cast iron excluded from the AIS requirements?

A: No. Cast iron products that fall under the definition of iron and steel products must comply with the AIS requirements.

13. Q: The guidance states that “construction materials” do not include mechanical equipment, but then identifies ductwork as a construction material. Please clarify.

A: Ductwork is not mechanical equipment, therefore it is considered a “construction material” and must comply with the AIS requirements.

14. Q: Do “meters” mentioned in EPA’s guidance as non-construction materials include both flow meters and water meters?

A: Yes. “Meters” includes any type of meter, including: flow meters, wholesale meters, and water meters/service connections.

15. Q: Must coiled steel be domestic?

A: Yes. Coiled steel is an intermediate product used in the production of steel pipe and must come from a U.S. source or subject to a waiver in order to comply with the AIS requirements.

16. Q: Are pig iron, direct reduced iron (DRI), and ingot considered raw materials?

A: No. These are considered intermediate products used in the production of iron or steel and must come from a U.S. source or subject to a waiver in order to comply with the AIS requirements.

17. Q: Can assistance recipients rely on a marking that reads, "Made in the USA," as evidence that all processes took place in the U.S.?

A: No. This designation is not consistent with our requirements that all manufacturing processes of iron and steel products must take place in the U.S.

18. Q: When determining what constitutes a product made "primarily" of iron or steel, who makes this determination?

A: The manufacturer will show if its product qualifies as primarily made of iron or steel. The recipient should expect the manufacturer to provide documentation/ certification that its product is AIS compliant.

19. Q: Do aerators need to be produced domestically in order to comply with AIS?

A: No. Aerators, similar to pumps, are mechanical equipment that do not need to meet the AIS requirements. "Blowers/aeration equipment, compressors" are listed in EPA's guidance as non-construction materials.

20. Q: Are Sluice and Slide Gates considered valves?

A: No. Valves are products that are generally encased / enclosed with a body, bonnet, and stem. Examples include enclosed butterfly, ball, globe, piston, check, wedge, and gate valves. Furthermore, "gates" (meaning sluice, slide or weir gates) are listed in EPA's guidance as non-construction materials.

AIS PROCESS QUESTIONS

21. Q: Will notices of waiver applications be published in the federal register?

A: No. Applications for waivers will be published on EPA's website (http://water.epa.gov/grants_funding/aisrequirement.cfm). EPA will provide 15 days for open public comment, as noted on the website.

22. Q: Will states be collecting the step certification paper trail, as presented in the AIS guidance?

A. No. Assistance recipients must maintain documentation of compliance with AIS. EPA recommends use of the step certification process. This process is a best practice and traces all manufacturing of iron and steel products to the U.S. If the process is used, the state does not have to collect the documentation. The documents must be kept by the assistance recipient and reviewed by the state during project reviews.

23. Q: Why is it considered a best practice for states to conduct site visits, when it is the assistance recipient's responsibility to meet the AIS requirements?

A: It is both the assistance recipient's and the state's responsibility to ensure compliance with the AIS requirements. The state is the recipient of a federal grant and must comply with all grant conditions, including a condition requiring that the AIS requirements be adhered to. Therefore, it is recommended that states conduct site visits of projects during construction and review documentation demonstrating the assistance recipient's proof of compliance.

24. Q: Please further define the state's role in the waiver process.

A: The state's role in the waiver process is to review any waiver requests submitted to the state in order to ensure that all necessary information has been provided by the assistance recipient prior to forwarding the request to EPA. If a state finds the request lacking, the state should work with the assistance recipient to help obtain complete information.

25. Q: How much time does EPA have to evaluate the waiver during the evaluation step?

A: At a minimum, EPA is required to provide 15 days for open public comment. There is no specific deadline or time limit for EPA to review waiver requests. Each waiver request will come with its own specific details and circumstances and may require a different amount of time for review and analysis. For example, public interest waivers in general may take longer to review than availability waivers which are typically more straightforward. However, EPA understands that construction may be delayed while waiting for a waiver and will make every effort to review and issue decisions on waiver requests in a timely manner.

PROJECT QUESTIONS

26. Q: What if a project is funded by another funding entity (i.e., United States Department of Agriculture – Rural Development) where AIS is not required and begins construction after January 17, 2014 but then applies to the SRF to refinance the project? Are they ineligible?

A: The project is not ineligible. AIS requirements will apply to any construction that occurs after the assistance agreement is signed, through the end of construction. If construction is complete, there is no retroactive application of the AIS requirements.

27. Q: If the assistance recipient can demonstrate through market research that the AIS requirement will exceed the 25 percent cost threshold, is the entire project exempt from the AIS requirement?

A: If the waiver application shows that the inclusion of American iron and steel products causes the entire cost of the project to increase by more the 25 percent, a waiver may be granted for the entirety of the project.

28. Q: Can the recipient use non-SRF funds to pay for the non-compliant item.

A: No. It is not an acceptable to use non-SRF funds to pay for a non-compliant item. The Consolidated Appropriations Act of 2014 requires that all iron and steel products, no matter the source of funding, must be made in the U.S. if SRF funds are used in the project.

29. Q: What constitutes “satisfactory quality” as defined in the AIS guidance, in reference to the availability waiver process.

A: “Satisfactory quality” means the product meets the project design specifications. A waiver may be granted if a recipient determines that the project plans and design would be compromised because there are no American made products available that meet the project design specifications.

30. Q: The guidance states that the AIS requirement applies to any project “funded in whole or in part” by an SRF. Where is this in the Act?

A: The Act states that, “None of the funds made available by a ... [State SRF program] ... shall be used for a project for the construction, alteration, maintenance, or repair of a public water system or treatment works unless all of the iron and steel products used in the project are produced in the United States.” This sentence clearly states that no SRF program may use its funds for a project unless all of the iron and steel products used in the project are made in the U.S. This is true even if only \$1 of SRF funding is used in the project.

31. Q: There is always an expectation on the part of an assistance recipient that the construction phase of a planning and/or design only loan will be funded through the SRF. If the original planning and/or design only loan was executed prior to a January 17, 2014, does this mean the entire project will be exempt from the AIS requirement?

A: If the original loan includes construction, and was executed prior to January 17, 2014, then the AIS provision does not apply to the project. If the original loan was only for planning and/or design, then a written commitment or documented “expectation” is needed to show exemption from the

requirements. Appearance on a priority list in an Intended Use Plan along with written reasonable assurance from the state that the recipient will receive SRF funding for project construction could provide sufficient evidence of “expectation of funding”.

32. Q: What if there has been a change order or redesign requiring new plans and specifications to be approved and they were approved after January 17, 2014: does the project now have to comply with AIS?

A: In most cases, no. Change orders are typically small enough changes that the original plan and specification date will still hold true. For example, if a pipe alignment has to be changed for a block or two due to unforeseen conditions, but new plans and specifications had to be submitted for this section of the project, then that could be considered a minor change. However, if there has been a major redesign, perhaps the whole project had to be redesigned starting from scratch, then the new plans and specification approval date would apply.

33. Q: What if the bids on a project with plans and specifications approved before January 17, 2014 but the loan is signed after January 17, 2014 come in low, and there is significant funding remaining in the loan agreement, so the community designs a second project with the remaining funds: does that project have to comply with the AIS requirements?

A: If the second project is closely related in purpose, place and time to the first project, then the second project would be exempt from the AIS requirements. It is the assistance recipient’s responsibility (with state oversight) to show that a project is closely related, or not, in purpose, place and time.

34. Q: What if the assistance agreement was signed after January 17, 2014, state approval of plans for the first phase of the project was in place prior to January 17, 2014, but state approval of the plans for the second phase of the project was received after January 17, 2014?

A: In such a case, the AIS provision would not apply to the first phase of the project. If the second phase of the project is considered the same project as the first phase, due to its close relation in purpose, place and time, the entire project may be exempt. It is the assistance recipient’s responsibility (with state oversight) to show that phases of a project is closely related, or not, in purpose, place and time.

35. Q: Do products purchased through procurement-only contracts have to be comply with AIS?

A: Yes. For projects funded by SRF, the products procured under any form of contract must comply with AIS. A procurement-only contract generally involves the bulk purchase of common items (such as pipe, concrete, and/or pumps) of independent timing from a set of planned projects. If products which are purchased through a procurement-only contract are being installed under another contract, the procurement-only contract would probably not be considered a separate project in purpose, place and time; and therefore, would have to comply with the AIS requirements.

March 2015

American Iron & Steel Requirement for the Clean Water and Drinking Water State Revolving Funds

Q&A Part 3

*For CWSRF and DWSRF: On **January 17, 2014**, Public Law 113-76, the "Consolidated Appropriations Act, 2014," was enacted and included an American Iron and Steel requirement for the Clean Water and Drinking Water State Revolving Fund programs through the end of fiscal year 2014. Since then, the AIS requirement has continued for both programs, but through different statutes, with a few changes as described in the questions and answers provided below.*

*For CWSRF: On **June 10, 2014**, the Water Resources Reform and Development Act amended the Clean Water Act to include permanent requirements for the use of AIS products in CWSRF assistance agreements. Section 608 of the CWA now contains requirements for AIS that repeat those of the Consolidated Appropriations Act, 2014. All CWSRF assistance agreements must comply with Section 608 of the CWA for implementation of the permanent AIS requirement.*

*For DWSRF: On **December 16, 2014**, the President signed Public Law 113-235, the "Consolidated and Further Continuing Appropriations Act, 2015," which provides fiscal year 2015 full-year appropriations through September 30, 2015. This law continues the requirement for the use of AIS products in DWSRF assistance agreements through September 30, 2015.*

CWSRF PROGRAM

- 1. Q: The Water Resources Reform and Development Act amended the Clean Water Act to include permanent requirements for the use of AIS for CWSRF funded assistance agreements. Does the CWA include an exemption for plans and specifications approved prior to the enactment of the legislation similar to the exemption included in the Consolidated Appropriations Act (CAA) 2014?**

A: Yes. The WRRDA amendment to the CWA, which included AIS requirements, included a similar exemption as the CAA 2014. For any CWSRF assistance agreement signed on or after October 1, 2014, if the plans and specifications were approved prior to June 10, 2014 (the enactment of WRRDA), then the project is exempt from AIS requirements. For assistance agreements signed prior to October 1, 2014, the previous dates in the CAA 2014 apply (see March 20, 2014, AIS guidance document).

If a project does not require approved engineering plans and specifications, the bid advertisement date will count in lieu of the plans and specifications approval date for purposes of this exemption in Section 608 (f).

The following table summarizes AIS exemptions based on the plans and specifications approval date for CWSRF funded projects.

CWSRF AIS Project Exemption Based on Plans and Specifications Approval Date		
<u>Assistance Agreement Signed:</u>	<u>Exempt from AIS if Plans and Specifications Were Approved Before:</u>	<u>Basis for Exemption:</u>
1/17/2014 through 9/30/2014	4/15/2014	<ul style="list-style-type: none"> • Consolidated Appropriations Act 2014 • National waiver signed 4/15/2014*
On or after 10/1/2014	6/10/2014	<ul style="list-style-type: none"> • Clean Water Act Section 608

** To be covered by the national waiver, the plans and specifications had to be submitted to the state prior to 1/17/2014*

2. Q: Does the AIS requirement apply to refinanced CWSRF projects?

A: Yes, in some cases. If a project began construction, financed from a non-CWSRF source prior to June 10, 2014, but is refinanced through a CWSRF assistance agreement executed on or after October 1, 2014, AIS requirements will apply to all construction that occurs on or after June 10, 2014, through completion of construction, unless engineering plans and specifications were approved by the responsible state agency prior to June 10, 2014. For CWSRF projects funded on or after October 1, 2014, there is no retroactive application of the AIS requirements where a refinancing occurs for a project that has completed construction prior to June 10, 2014.

DWSRF PROGRAM

3. Q: The Consolidated and Further Continuing Appropriations Act 2015 continues the AIS requirements for DWSRF funded assistance agreements. Does the Act include an exemption for plans and specifications approved prior to the enactment of the legislation, similar to the exemption included in the Consolidated Appropriations Act (CAA) 2014?

A: Yes. The Consolidated and Further Continuing Appropriations Act 2015 includes a similar exemption as the CAA 2014. For any assistance agreement signed on or after December 16, 2014 (the enactment of the Act), if the plans and specifications were approved prior to December 16, 2014, then the project is exempt from the AIS requirements. For assistance agreements signed prior to December 16, 2014, the previous dates in the CAA 2014 apply (see March 20, 2014 AIS guidance document).

If a project does not require approved engineering plans and specifications, the bid advertisement date will count in lieu of the plans and specifications approval date for purposes of the exemption in Section 424(f).

4. Q: Do DWSRF assistance agreements signed during the time period between September 30, 2014, and December 16, 2014, still have to comply with the AIS requirements?

A: Yes. The Continuing Appropriations Resolution 2015 was signed on September 19, 2014, which extended funding for the DWSRF with the same conditions that were made applicable by the language in the Fiscal Year 2014 appropriations, including the requirement for the use of American Iron and Steel products in projects receiving financial assistance from the DWSRF. Therefore, all assistance agreements starting October 1, 2014, through the enactment of the Consolidated and Further Continuing Appropriations Act 2015 (signed December 16, 2014), must include the AIS requirements. However, if the plans and specifications for any of these projects were approved prior to April 15, 2014 (the date the national waiver was signed), then the project is exempt from the AIS requirements.

The following table summarizes AIS exemptions based on the plans and specifications approval date for DWSRF funded projects.

DWSRF AIS Project Exemption Based on Plans and Specifications Approval Date		
<u>Assistance Agreement Signed:</u>	<u>Exempt from AIS if Plans and Specifications Were Approved Before:</u>	<u>Basis for Exemption:</u>
1/17/2014 through 9/30/2014	4/15/2014	<ul style="list-style-type: none"> • Consolidated Appropriations Act 2014 • National waiver signed 4/15/2014*
10/1/2014 through 12/15/2014	4/15/2014	<ul style="list-style-type: none"> • Continuing Appropriations Resolution 2015 (continued CAA 2014 requirements)** • National waiver signed 4/15/2014*
12/16/2014 through 9/30/2015	12/16/2014	<ul style="list-style-type: none"> • Consolidated and Further Continuing Appropriations Act 2015

** To be covered by the national waiver, the plans and specifications had to be submitted to the state prior to 1/17/2014*

*** Following the first continuing resolution, there were two additional CRs to fill the gap between 12/11/2014 and 12/16/2014*

5. Q: Does the AIS requirement apply to refinanced DWSRF projects?

A: Yes, in some cases. If a project began construction, financed from a non-DWSRF source prior to December 16, 2014, but is refinanced through a DWSRF assistance agreement executed on or after December 16, 2014, AIS requirements will apply to all construction that occurs on or after December 16, 2014, through completion of construction, unless engineering plans and

specifications were approved by the responsible state agency prior to December 16, 2014. For DWSRF projects funded on or after December 16, 2014, there is no retroactive application of the AIS requirements where a refinancing occurs for a project that has completed construction prior to December 16, 2014.

BOTH CWSRF AND DWSRF PROGRAMS

- 6. Q: If a coating is applied to the external surface of a domestic iron or steel component, and the application takes place outside of the United States, would the product be compliant under the AIS requirements?**

A: Yes. The product would still be considered a compliant product under AIS requirements. Any coating processes that are applied to the external surface of iron and steel components that would otherwise be AIS compliant would not disqualify the product from meeting the AIS requirements regardless of where the coating processes occur, provided that final assembly of the product occurs in the United States.

The exemption above only applies to coatings on the *external surface* of iron and steel components. It does not apply to coatings or linings on internal surfaces of iron and steel products, such as the lining of lined pipes. All manufacturing processes for lined pipes, including the application of pipe lining, must occur in the United States for the product to be compliant with AIS requirements.

EXHIBIT H – AMERICAN IRON & STEEL CERTIFICATION

**CERTIFICATION BY THE BORROWER OF COMPLIANCE WITH THE AMERICAN
IRON & STEEL REQUIREMENTS SET FORTH IN THE LOAN AGREEMENT**

The Borrower hereby certifies that it has obtained certification(s) of compliance with the American Iron & Steel requirements set forth in the loan agreement from each contractor and subcontractor working on the Project(s) funded with the proceeds from the Loan. To the best of the Borrower’s knowledge, the costs being reimbursed with this requisition #_____ are in compliance with the American Iron & Steel provision(s).

Date: _____

Signed: _____
By: Authorized Official

Appendix H

EPA – Davis-Bacon Prevailing Wage Requirements

DAVIS-BACON PREVAILING WAGE REQUIREMENTS

(a) GENERAL CONTRACT AND SUBCONTRACT PROVISIONS

For any contract in excess of \$2,000 which is entered into for the actual construction, alteration and/or repair, including painting and decorating, of a treatment work under the CWSRF or a construction project under the DWSRF financed in whole or in part from Federal funds or in accordance with guarantees of a Federal agency or financed from funds obtained by pledge of any contract of a Federal agency to make a loan, grant or annual contribution (except where a different meaning is expressly indicated), and which is subject to the labor standards provisions of any of the acts listed in §5.1 or the FY 2010 appropriation, the following clauses shall be inserted in full:

(1) Minimum Wages

(i) All laborers and mechanics employed or working upon the site of the work will be paid unconditionally and not less often than once a week, and without subsequent deduction or rebate on any account (except such payroll deductions as are permitted by regulations issued by the Secretary of Labor under the Copeland Act (29 CFR part 3)), the full amount of wages and bona fide fringe benefits (or cash equivalents thereof) due at time of payment computed at rates not less than those contained in the wage determination of the Secretary of Labor which is attached hereto and made a part hereof, regardless of any contractual relationship which may be alleged to exist between the contractor and such laborers and mechanics.

Contributions made or costs reasonably anticipated for bona fide fringe benefits under section 1(b)(2) of the Davis-Bacon Act on behalf of laborers or mechanics are considered wages paid to such laborers or mechanics, subject to the provisions of paragraph (a)(1)(iv) of this section; also, regular contributions made or costs incurred for more than a weekly period (but not less often than quarterly) under plans, funds, or programs which cover the particular weekly period, are deemed to be constructively made or incurred during such weekly period. Such laborers and mechanics shall be paid the appropriate wage rate and fringe benefits on the wage determination for the classification of work actually performed, without regard to skill, except as provided in §5.5(a)(4). Laborers or mechanics performing work in more than one classification may be compensated at the rate specified for each classification for the time actually worked therein: *Provided*, That the employer's payroll records accurately set forth the time spent in each classification in which work is performed. The wage determination (including any additional classification and wage rates conformed under paragraph (a)(1)(ii) of this section) and the Davis-Bacon poster (WH-1321) shall be posted at all times by the contractor and its subcontractors at the site of the work in a prominent and accessible place where it can be easily seen by the workers.

Wage determinations may be obtained from the U.S. Department of Labor's website, www.dol.gov.

(ii)(A) The Owner, on behalf of the EPA, shall require that any class of laborers or mechanics, including helpers, which is not listed in the wage determination and which is to be employed under the contract shall be classified in conformance with the wage determination. The State award official shall approve an additional classification and wage rate and fringe benefits therefore only when the following criteria have been met:

(1) The work to be performed by the classification requested is not performed by a classification in the wage determination; and

(2) The classification is utilized in the area by the construction industry; and

(3) The proposed wage rate, including any bona fide fringe benefits, bears a reasonable relationship to the wage rates contained in the wage determination.

(B) If the contractor and the laborers and mechanics to be employed in the classification (if known), or their representatives, and the Owner agree on the classification and wage rate (including the amount designated for fringe benefits where appropriate), documentation of the action taken and the request, including the local wage determination shall be sent by the Owner to the State award official. The State award official will transmit the request to the Administrator of the Wage and Hour Division, Employment Standards Administration, U.S. Department of Labor, Washington, DC 20210 and to the EPA DB Regional Coordinator concurrently. The Administrator, or an authorized representative, will approve, modify, or disapprove every additional classification action within 30 days of receipt and so advise the State award official or will notify the State award official within the 30-day period that additional time is necessary.

(C) In the event the contractor, the laborers or mechanics to be employed in the classification or their representatives, and the Owner do not agree on the proposed classification and wage rate (including the amount designated for fringe benefits, where appropriate), the award official shall refer the questions, including the views of all interested parties and the recommendation of the State award official, to the Administrator for determination. The request shall be sent to the EPA DB Regional Coordinator concurrently. The Administrator, or an authorized representative, will issue a determination within 30 days of receipt and so advise the State award official or will notify the State award official within the 30-day period that additional time is necessary.

(D) The wage rate (including fringe benefits where appropriate) determined pursuant to paragraphs (a)(1)(ii) (B) or (C) of this section, shall be paid to all workers performing work in the classification under this contract from the first day on which work is performed in the classification.

(iii) Whenever the minimum wage rate prescribed in the contract for a class of laborers or mechanics includes a fringe benefit which is not expressed as an hourly rate, the contractor shall either pay the benefit as stated in the wage determination or shall pay another bona fide fringe benefit or an hourly cash equivalent thereof.

(iv) If the contractor does not make payments to a trustee or other third person, the contractor may consider as part of the wages of any laborer or mechanic the amount of any costs reasonably anticipated in providing bona fide fringe benefits under a plan or program, *Provided*, That the Secretary of Labor has found, upon the written request of the contractor, that the applicable standards of the Davis-Bacon Act have been met. The Secretary of Labor may require the contractor to set aside in a separate account assets for the meeting of obligations under the plan or program.

(2) Withholding

The Owner, shall upon written request of the EPA Award Official or an authorized representative of the Department of Labor, withhold or cause to be withheld from the contractor under this

(1) The work to be performed by the classification requested is not performed by a classification in the wage determination; and

(2) The classification is utilized in the area by the construction industry; and

(3) The proposed wage rate, including any bona fide fringe benefits, bears a reasonable relationship to the wage rates contained in the wage determination.

(B) If the contractor and the laborers and mechanics to be employed in the classification (if known), or their representatives, and the Owner agree on the classification and wage rate (including the amount designated for fringe benefits where appropriate), documentation of the action taken and the request, including the local wage determination shall be sent by the Owner to the State award official. The State award official will transmit the request to the Administrator of the Wage and Hour Division, Employment Standards Administration, U.S. Department of Labor, Washington, DC 20210 and to the EPA DB Regional Coordinator concurrently. The Administrator, or an authorized representative, will approve, modify, or disapprove every additional classification action within 30 days of receipt and so advise the State award official or will notify the State award official within the 30-day period that additional time is necessary.

(C) In the event the contractor, the laborers or mechanics to be employed in the classification or their representatives, and the Owner do not agree on the proposed classification and wage rate (including the amount designated for fringe benefits, where appropriate), the award official shall refer the questions, including the views of all interested parties and the recommendation of the State award official, to the Administrator for determination. The request shall be sent to the EPA DB Regional Coordinator concurrently. The Administrator, or an authorized representative, will issue a determination within 30 days of receipt and so advise the State award official or will notify the State award official within the 30-day period that additional time is necessary.

(D) The wage rate (including fringe benefits where appropriate) determined pursuant to paragraphs (a)(1)(ii) (B) or (C) of this section, shall be paid to all workers performing work in the classification under this contract from the first day on which work is performed in the classification.

(iii) Whenever the minimum wage rate prescribed in the contract for a class of laborers or mechanics includes a fringe benefit which is not expressed as an hourly rate, the contractor shall either pay the benefit as stated in the wage determination or shall pay another bona fide fringe benefit or an hourly cash equivalent thereof.

(iv) If the contractor does not make payments to a trustee or other third person, the contractor may consider as part of the wages of any laborer or mechanic the amount of any costs reasonably anticipated in providing bona fide fringe benefits under a plan or program, *Provided*, That the Secretary of Labor has found, upon the written request of the contractor, that the applicable standards of the Davis-Bacon Act have been met. The Secretary of Labor may require the contractor to set aside in a separate account assets for the meeting of obligations under the plan or program.

(2) Withholding

The Owner, shall upon written request of the EPA Award Official or an authorized representative of the Department of Labor, withhold or cause to be withheld from the contractor under this

contract or any other Federal contract with the same prime contractor, or any other federally-assisted contract subject to Davis-Bacon prevailing wage requirements, which is held by the same prime contractor, so much of the accrued payments or advances as may be considered necessary to pay laborers and mechanics, including apprentices, trainees, and helpers, employed by the contractor or any subcontractor the full amount of wages required by the contract. In the event of failure to pay any laborer or mechanic, including any apprentice, trainee, or helper, employed or working on the site of the work, all or part of the wages required by the contract, the (Agency) may, after written notice to the contractor, sponsor, applicant, or owner, take such action as may be necessary to cause the suspension of any further payment, advance, or guarantee of funds until such violations have ceased.

(3) Payrolls and Basic Records

(i) Payrolls and basic records relating thereto shall be maintained by the contractor during the course of the work and preserved for a period of three years thereafter for all laborers and mechanics working at the site of the work. Such records shall contain the name, address, and social security number of each such worker, his or her correct classification, hourly rates of wages paid (including rates of contributions or costs anticipated for bona fide fringe benefits or cash equivalents thereof of the types described in section 1(b)(2)(B) of the Davis-Bacon Act), daily and weekly number of hours worked, deductions made and actual wages paid. Whenever the Secretary of Labor has found under 29 CFR 5.5(a)(1)(iv) that the wages of any laborer or mechanic include the amount of any costs reasonably anticipated in providing benefits under a plan or program described in section 1(b)(2)(B) of the Davis-Bacon Act, the contractor shall maintain records which show that the commitment to provide such benefits is enforceable, that the plan or program is financially responsible, and that the plan or program has been communicated in writing to the laborers or mechanics affected, and records which show the costs anticipated or the actual cost incurred in providing such benefits. Contractors employing apprentices or trainees under approved programs shall maintain written evidence of the registration of apprenticeship programs and certification of trainee programs, the registration of the apprentices and trainees, and the ratios and wage rates prescribed in the applicable programs.

(ii)(A) The contractor shall submit weekly for each week in which any contract work is performed a copy of all payrolls to the Owner, that is, the entity that receives the sub-grant or loan from the State capitalization grant recipient. Such documentation shall be available on request of the State recipient or EPA. As to each payroll copy received, the Owner shall provide written confirmation in a form satisfactory to the State indicating whether or not the project is in compliance with the requirements of 29 CFR 5.5(a)(1) based on the most recent payroll copies for the specified week. The payrolls submitted shall set out accurately and completely all of the information required to be maintained under 29 CFR 5.5(a)(3)(i), except that full social security numbers and home addresses shall not be included on weekly payrolls. Instead the payrolls shall only need to include an individually identifying number for each employee (e.g. , the last four digits of the employee's social security number). The required weekly payroll information may be submitted in any form desired. Optional Form WH-347 is available for this purpose from the Wage and Hour Division Web site at <http://www.dol.gov/esa/whd/forms/wh347instr.htm> or its successor site. The prime contractor is responsible for the submission of copies of payrolls by all subcontractors. Contractors and subcontractors shall maintain the full social security number and current address of each covered worker, and shall provide them upon request to the owner for transmission to the State or EPA if requested by EPA, the State, the contractor, or the Wage and Hour Division of the Department of Labor for purposes of an investigation or audit of

contract or any other Federal contract with the same prime contractor, or any other federally-assisted contract subject to Davis-Bacon prevailing wage requirements, which is held by the same prime contractor, so much of the accrued payments or advances as may be considered necessary to pay laborers and mechanics, including apprentices, trainees, and helpers, employed by the contractor or any subcontractor the full amount of wages required by the contract. In the event of failure to pay any laborer or mechanic, including any apprentice, trainee, or helper, employed or working on the site of the work, all or part of the wages required by the contract, the (Agency) may, after written notice to the contractor, sponsor, applicant, or owner, take such action as may be necessary to cause the suspension of any further payment, advance, or guarantee of funds until such violations have ceased.

(3) Payrolls and Basic Records

(i) Payrolls and basic records relating thereto shall be maintained by the contractor during the course of the work and preserved for a period of three years thereafter for all laborers and mechanics working at the site of the work. Such records shall contain the name, address, and social security number of each such worker, his or her correct classification, hourly rates of wages paid (including rates of contributions or costs anticipated for bona fide fringe benefits or cash equivalents thereof of the types described in section 1(b)(2)(B) of the Davis-Bacon Act), daily and weekly number of hours worked, deductions made and actual wages paid. Whenever the Secretary of Labor has found under 29 CFR 5.5(a)(1)(iv) that the wages of any laborer or mechanic include the amount of any costs reasonably anticipated in providing benefits under a plan or program described in section 1(b)(2)(B) of the Davis-Bacon Act, the contractor shall maintain records which show that the commitment to provide such benefits is enforceable, that the plan or program is financially responsible, and that the plan or program has been communicated in writing to the laborers or mechanics affected, and records which show the costs anticipated or the actual cost incurred in providing such benefits. Contractors employing apprentices or trainees under approved programs shall maintain written evidence of the registration of apprenticeship programs and certification of trainee programs, the registration of the apprentices and trainees, and the ratios and wage rates prescribed in the applicable programs.

(ii)(A) The contractor shall submit weekly for each week in which any contract work is performed a copy of all payrolls to the Owner, that is, the entity that receives the sub-grant or loan from the State capitalization grant recipient. Such documentation shall be available on request of the State recipient or EPA. As to each payroll copy received, the Owner shall provide written confirmation in a form satisfactory to the State indicating whether or not the project is in compliance with the requirements of 29 CFR 5.5(a)(1) based on the most recent payroll copies for the specified week. The payrolls submitted shall set out accurately and completely all of the information required to be maintained under 29 CFR 5.5(a)(3)(i), except that full social security numbers and home addresses shall not be included on weekly payrolls. Instead the payrolls shall only need to include an individually identifying number for each employee (e.g. , the last four digits of the employee's social security number). The required weekly payroll information may be submitted in any form desired. Optional Form WH-347 is available for this purpose from the Wage and Hour Division Web site at <http://www.dol.gov/esa/whd/forms/wh347instr.htm> or its successor site. The prime contractor is responsible for the submission of copies of payrolls by all subcontractors. Contractors and subcontractors shall maintain the full social security number and current address of each covered worker, and shall provide them upon request to the owner for transmission to the State or EPA if requested by EPA, the State, the contractor, or the Wage and Hour Division of the Department of Labor for purposes of an investigation or audit of

compliance with prevailing wage requirements. It is not a violation of this section for a prime contractor to require a subcontractor to provide addresses and social security numbers to the prime contractor for its own records, without weekly submission to the Owner.

(B) Each payroll submitted shall be accompanied by a "Statement of Compliance," signed by the contractor or subcontractor or his or her agent who pays or supervises the payment of the persons employed under the contract and shall certify the following:

(1) That the payroll for the payroll period contains the information required to be provided under §5.5 (a)(3)(ii) of Regulations, 29 CFR part 5, the appropriate information is being maintained under §5.5 (a)(3)(i) of Regulations, 29 CFR part 5, and that such information is correct and complete;

(2) That each laborer or mechanic (including each helper, apprentice, and trainee) employed on the contract during the payroll period has been paid the full weekly wages earned, without rebate, either directly or indirectly, and that no deductions have been made either directly or indirectly from the full wages earned, other than permissible deductions as set forth in Regulations, 29 CFR part 3;

(3) That each laborer or mechanic has been paid not less than the applicable wage rates and fringe benefits or cash equivalents for the classification of work performed, as specified in the applicable wage determination incorporated into the contract.

(C) The weekly submission of a properly executed certification set forth on the reverse side of Optional Form WH-347 shall satisfy the requirement for submission of the "Statement of Compliance" required by paragraph (a)(3)(ii)(B) of this section.

(D) The falsification of any of the above certifications may subject the contractor or subcontractor to civil or criminal prosecution under section 1001 of title 18 and section 231 of title 31 of the United States Code.

(iii) The contractor or subcontractor shall make the records required under paragraph (a)(3)(i) of this section available for inspection, copying, or transcription by authorized representatives of the State, EPA or the Department of Labor, and shall permit such representatives to interview employees during working hours on the job. If the contractor or subcontractor fails to submit the required records or to make them available, the Federal agency or State may, after written notice to the contractor, sponsor, applicant, or owner, take such action as may be necessary to cause the suspension of any further payment, advance, or guarantee of funds. Furthermore, failure to submit the required records upon request or to make such records available may be grounds for debarment action pursuant to 29 CFR 5.12.

(4) Apprentices and Trainees

(i) *Apprentices.* Apprentices will be permitted to work at less than the predetermined rate for the work they performed when they are employed pursuant to and individually registered in a bona fide apprenticeship program registered with the U.S. Department of Labor, Employment and Training Administration, Office of Apprenticeship Training, Employer and Labor Services, or with a State Apprenticeship Agency recognized by the Office, or if a person is employed in his or her first 90 days of probationary employment as an apprentice in such an apprenticeship program, who is not individually registered in the program, but who has been certified by the Office of

Apprenticeship Training, Employer and Labor Services or a State Apprenticeship Agency (where appropriate) to be eligible for probationary employment as an apprentice. The allowable ratio of apprentices to journeymen on the job site in any craft classification shall not be greater than the ratio permitted to the contractor as to the entire work force under the registered program. Any worker listed on a payroll at an apprentice wage rate, who is not registered or otherwise employed as stated above, shall be paid not less than the applicable wage rate on the wage determination for the classification of work actually performed. In addition, any apprentice performing work on the job site in excess of the ratio permitted under the registered program shall be paid not less than the applicable wage rate on the wage determination for the work actually performed. Where a contractor is performing construction on a project in a locality other than that in which its program is registered, the ratios and wage rates (expressed in percentages of the journeyman's hourly rate) specified in the contractor's or subcontractor's registered program shall be observed. Every apprentice must be paid at not less than the rate specified in the registered program for the apprentice's level of progress, expressed as a percentage of the journeymen hourly rate specified in the applicable wage determination. Apprentices shall be paid fringe benefits in accordance with the provisions of the apprenticeship program. If the apprenticeship program does not specify fringe benefits, apprentices must be paid the full amount of fringe benefits listed on the wage determination for the applicable classification. If the Administrator determines that a different practice prevails for the applicable apprentice classification, fringes shall be paid in accordance with that determination. In the event the Office of Apprenticeship Training, Employer and Labor Services, or a State Apprenticeship Agency recognized by the Office, withdraws approval of an apprenticeship program, the contractor will no longer be permitted to utilize apprentices at less than the applicable predetermined rate for the work performed until an acceptable program is approved.

(ii) *Trainees*. Except as provided in 29 CFR 5.16, trainees will not be permitted to work at less than the predetermined rate for the work performed unless they are employed pursuant to and individually registered in a program which has received prior approval, evidenced by formal certification by the U.S. Department of Labor, Employment and Training Administration. The ratio of trainees to journeymen on the job site shall not be greater than permitted under the plan approved by the Employment and Training Administration. Every trainee must be paid at not less than the rate specified in the approved program for the trainee's level of progress, expressed as a percentage of the journeyman hourly rate specified in the applicable wage determination. Trainees shall be paid fringe benefits in accordance with the provisions of the trainee program. If the trainee program does not mention fringe benefits, trainees shall be paid the full amount of fringe benefits listed on the wage determination unless the Administrator of the Wage and Hour Division determines that there is an apprenticeship program associated with the corresponding journeyman wage rate on the wage determination which provides for less than full fringe benefits for apprentices. Any employee listed on the payroll at a trainee rate who is not registered and participating in a training plan approved by the Employment and Training Administration shall be paid not less than the applicable wage rate on the wage determination for the classification of work actually performed. In addition, any trainee performing work on the job site in excess of the ratio permitted under the registered program shall be paid not less than the applicable wage rate on the wage determination for the work actually performed. In the event the Employment and Training Administration withdraws approval of a training program, the contractor will no longer be permitted to utilize trainees at less than the applicable predetermined rate for the work performed until an acceptable program is approved.

(iii) *Equal employment opportunity*. The utilization of apprentices, trainees and journeymen under this part shall be in conformity with the equal employment opportunity requirements of Executive Order 11246, as amended, and 29 CFR part 30.

(5) Compliance with Copeland Act Requirements

The contractor shall comply with the requirements of 29 CFR part 3, which are incorporated by reference in this contract.

(6) Subcontracts

The contractor or subcontractor shall insert in any subcontracts the clauses contained in 29 CFR 5.5(a)(1) through (10) and such other clauses as the (write in the name of the Federal agency) may by appropriate instructions require, and also a clause requiring the subcontractors to include these clauses in any lower tier subcontracts. The prime contractor shall be responsible for the compliance by any subcontractor or lower tier subcontractor with all the contract clauses in 29 CFR 5.5.

(7) Contract Termination: Debarment

A breach of the contract clauses in 29 CFR 5.5 may be grounds for termination of the contract, and for debarment as a contractor and a subcontractor as provided in 29 CFR 5.12.

(8) Compliance with Davis-Bacon and Related Act Requirements

All rulings and interpretations of the Davis-Bacon and Related Acts contained in 29 CFR parts 1, 3, and 5 are herein incorporated by reference in this contract.

(9) Disputes Concerning Labor Standards

Disputes arising out of the labor standards provisions of this contract shall not be subject to the general disputes clause of this contract. Such disputes shall be resolved in accordance with the procedures of the Department of Labor set forth in 29 CFR parts 5, 6, and 7. Disputes within the meaning of this clause include disputes between the contractor (or any of its subcontractors) and the Owner, the State, EPA, the U.S. Department of Labor, or the employees or their representatives.

(10) Certification of Eligibility

(i) By entering into this contract, the contractor certifies that neither it (nor he or she) nor any person or firm who has an interest in the contractor's firm is a person or firm ineligible to be awarded Government contracts by virtue of section 3(a) of the Davis-Bacon Act or 29 CFR 5.12(a)(1).

(ii) No part of this contract shall be subcontracted to any person or firm ineligible for award of a Government contract by virtue of section 3(a) of the Davis-Bacon Act or 29 CFR 5.12(a)(1).

(iii) The penalty for making false statements is prescribed in the U.S. Criminal Code, 18 U.S.C. 1001.

(b) CONTRACT WORK HOURS AND SAFETY STANDARDS ACT

For any contract in an amount in excess of \$100,000 and subject to the overtime provisions of the Contract Work Hours and Safety Standards Act, the following clauses set forth in paragraphs (b) (1), (2), (3) and (4) of this section shall be inserted in full. These clauses shall be inserted in addition to the clauses required in Section (a), above or 29 CFR 4.6. As used in this paragraph, the terms laborers and mechanics include watchmen and guards.

(1) Overtime Requirements

No contractor or subcontractor contracting for any part of the contract work which may require or involve the employment of laborers or mechanics shall require or permit any such laborer or mechanic in any workweek in which he or she is employed on such work to work in excess of forty hours in such workweek unless such laborer or mechanic receives compensation at a rate not less than one and one-half times the basic rate of pay for all hours worked in excess of forty hours in such workweek.

(2) Violation; Liability for Unpaid Wages; Liquidated Damages

In the event of any violation of the clause set forth in paragraph (b)(1) of this section the contractor and any subcontractor responsible therefor shall be liable for the unpaid wages. In addition, such contractor and subcontractor shall be liable to the United States (in the case of work done under contract for the District of Columbia or a territory, to such District or to such territory), for liquidated damages. Such liquidated damages shall be computed with respect to each individual laborer or mechanic, including watchmen and guards, employed in violation of the clause set forth in paragraph (b)(1) of this section, in the sum of \$10 for each calendar day on which such individual was required or permitted to work in excess of the standard workweek of forty hours without payment of the overtime wages required by the clause set forth in paragraph (b)(1) of this section.

(3) Withholding for Unpaid Wages and Liquidated Damages

The Owner, upon written request of the EPA Award Official or an authorized representative of the Department of Labor shall withhold or cause to be withheld, from any moneys payable on account of work performed by the contractor or subcontractor under any such contract or any other Federal contract with the same prime contractor, or any other federally-assisted contract subject to the Contract Work Hours and Safety Standards Act, which is held by the same prime contractor, such sums as may be determined to be necessary to satisfy any liabilities of such contractor or subcontractor for unpaid wages and liquidated damages as provided in the clause set forth in paragraph (b)(2) of this section.

(4) Subcontracts

The contractor or subcontractor shall insert in any subcontracts the clauses set forth in paragraph (b)(1) through (4) of this section and also a clause requiring the subcontractors to include these clauses in any lower tier subcontracts. The prime contractor shall be responsible for compliance by any subcontractor or lower tier subcontractor with the clauses set forth in paragraphs (b)(1) through (4) of this section.

(c) MAINTENANCE OF RECORDS

In addition to the clauses contained in Section (a), above, in any contract subject only to the Contract Work Hours and Safety Standards Act and not to any of the other statutes cited in §5.1 the contractor or subcontractor shall maintain payrolls and basic payroll records during the course of the work and shall preserve them for a period of three years from the completion of the contract for all laborers and mechanics, including guards and watchmen, working on the contract. Such records shall contain the name and address of each such employee, social security number, correct classifications, hourly rates of wages paid, daily and weekly number of hours worked, deductions made, and actual wages paid. The records to be maintained under this paragraph shall be made available by the contractor or subcontractor for inspection, copying, or transcription by authorized representatives of the Owner, the State, EPA and the Department of Labor, and the contractor or subcontractor will permit such representatives to interview employees during working hours on the job.

(d) COMPLIANCE VERIFICATION

(1) The Owner shall periodically interview a sufficient number of employees entitled to DB prevailing wages (covered employees) to verify that contractors or subcontractors are paying the appropriate wage rates. As provided in 29 CFR 5.6(a)(6), all interviews must be conducted in confidence. The Owner must use Standard Form 1445 (SF 1445) or equivalent documentation to memorialize the interviews. Copies of the SF 1445 are available from EPA on request.

(2) The Owner shall establish and follow an interview schedule based on its assessment of the risks of noncompliance with DB posed by contractors or subcontractors and the duration of the contract or subcontract. At a minimum, the Owner should conduct interviews with a representative group of covered employees within two weeks of each contractor or subcontractor's submission of its initial weekly payroll data and two weeks prior to the estimated completion date for the contract or subcontract. Owners must conduct more frequent interviews if the initial interviews or other information indicates that there is a risk that the contractor or subcontractor is not complying with DB . Owners shall immediately conduct necessary interviews in response to an alleged violation of the prevailing wage requirements. All interviews shall be conducted in confidence.

(3) The Owner shall periodically conduct spot checks of a representative sample of weekly payroll data to verify that contractors or subcontractors are paying the appropriate wage rates. The Owner shall establish and follow a spot check schedule based on its assessment of the risks of noncompliance with DB posed by contractors or subcontractors and the duration of the contract or subcontract. At a minimum, if practicable, the Owner should spot check payroll data within two weeks of each contractor or subcontractor's submission of its initial payroll data and two weeks prior to the completion date the contract or subcontract . Owners must conduct more frequent spot checks if the initial spot check or other information indicates that there is a risk that the contractor or subcontractor is not complying with DB. In addition, during the examinations the Owner shall verify evidence of fringe benefit plans and payments thereunder by contractors and subcontractors who claim credit for fringe benefit contributions.

(4) The Owner shall periodically review contractors and subcontractors use of apprentices and trainees to verify registration and certification with respect to apprenticeship and training programs approved by either the U.S Department of Labor or a state, as appropriate, and that contractors and subcontractors are not using disproportionate numbers of, laborers, trainees

and apprentices. These reviews shall be conducted in accordance with the schedules for spot checks and interviews described in Item 5(b) and (c) above.

(5) Owners must immediately report potential violations of the DB prevailing wage requirements to the EPA DB contact listed above and to the appropriate DOL Wage and Hour District Office listed at <http://www.dol.gov/esa/contacts/whd/america2.htm>.

Appendix I

EPA – Debarment and Suspension

DEBARMENT & SUSPENSION

Executive Order 12549--Debarment and Suspension

Source: The provisions of Executive Order 12549 of Feb. 18, 1986, appear at 51 FR 6370, 3 CFR, 1986 Comp., p. 189, unless otherwise noted.

By the authority vested in me as President by the Constitution and laws of the United States of America, and in order to curb fraud, waste, and abuse in Federal programs, increase agency accountability, and ensure consistency among agency regulations concerning debarment and suspension of participants in Federal programs, it is hereby ordered that:

Section 1. (a) To the extent permitted by law and subject to the limitations in Section 1(c), Executive departments and agencies shall participate in a system for debarment and suspension from programs and activities involving Federal financial and nonfinancial assistance and benefits. Debarment or suspension of a participant in a program by one agency shall have government-wide effect.

(b) Activities covered by this Order include but are not limited to: grants, cooperative agreements, contracts of assistance, loans, and loan guarantees.

(c) This Order does not cover procurement programs and activities, direct Federal statutory entitlements or mandatory awards, direct awards to foreign governments or public international organizations, benefits to an individual as a personal entitlement, or Federal employment.

Sec. 2. To the extent permitted by law, Executive departments and agencies shall:

(a) Follow government-wide criteria and government-wide minimum due process procedures when they act to debar or suspend participants in affected programs.

(b) Send to the agency designated pursuant to Section 5 identifying information concerning debarred and suspended participants in affected programs, participants who have agreed to exclusion from participation, and participants declared ineligible under applicable law, including Executive Orders. This information shall be included in the list to be maintained pursuant to Section 5.

(c) Not allow a party to participate in any affected program if any Executive department or agency has debarred, suspended, or otherwise excluded (to the extent specified in the exclusion agreement) that party from participation in an affected program. An agency may grant an exception permitting a debarred, suspended, or excluded party to participate in a particular transaction upon a written determination by the agency head or authorized designee stating the reason(s) for deviating from this Presidential policy. However, I intend that exceptions to this policy should be granted only infrequently.

Sec. 3. Executive departments and agencies shall issue regulations governing their implementation of this Order that shall be consistent with the guidelines issued under Section 6. Proposed regulations shall be submitted to the Office of Management and Budget for review within four months of the date of the guidelines issued under Section 6. The Director of the Office of Management and Budget may return for reconsideration proposed regulations that the Director believes are inconsistent with the guidelines. Final regulations shall be published within twelve months of the date of the guidelines.

Sec. 4. There is hereby constituted the Interagency Committee on Debarment and Suspension, which shall monitor implementation of this Order. The Committee shall consist of representatives of agencies designated by the Director of the Office of Management and Budget.

Sec. 5. The Director of the Office of Management and Budget shall designate a Federal agency to perform the following functions: maintain a current list of all individuals and organizations excluded from program participation under this Order, periodically distribute the list to Federal agencies, and study the feasibility of automating the list; coordinate with the lead agency responsible for government-wide debarment and suspension of contractors; chair the Interagency Committee established by Section 4; and report periodically to the Director on implementation of this Order, with the first report due within two years of the date of the Order.

Sec. 6. The Director of the Office of Management and Budget is authorized to issue guidelines to Executive departments and agencies that govern which programs and activities are covered by this Order, prescribe government-wide criteria and government-wide minimum due process procedures, and set forth other related details for the effective administration of the guidelines.

Sec. 7. The Director of the Office of Management and Budget shall report to the President within three years of the date of this Order on Federal agency compliance with the Order, including the number of exceptions made under Section 2(c), and shall make recommendations as are appropriate further to curb fraud, waste, and abuse.

Implementation in the SRF Programs

A company or individual who is debarred or suspended cannot participate in primary and lower-tiered covered transactions. These transactions include SRF loans and contracts and subcontracts awarded with SRF loan funds.

Under 40 C.F.R. 32.510, the SRF agency must submit a certification stating that it shall not knowingly enter into any transaction with a person who is proposed for debarment, suspended, declared ineligible, or voluntarily excluded from participation in the SRF program. This certification is reviewed by the EPA regional office before the capitalization grant is awarded.

A recipient of SRF assistance directly made available by capitalization grants must provide a certification that it will not knowingly enter into a contract with anyone who is ineligible under the regulations to participate in the project. Contractors on the project have to provide a similar certification prior to the award of a contract and subcontractors on the project have to provide the general contractor with the certification prior to the award of any subcontract.

In addition to actions taken under 40 C.F.R. Part 32, there are a wide range of other sanctions that can render a party ineligible to participate in the SRF program. Lists of debarred, suspended and otherwise ineligible parties are maintained by the General Services Administration and should be checked by the SRF agency and all recipients of funds directly made available by capitalization grants to ensure the accuracy of certifications.

Additional References

C 40 C.F.R. Part 32: EPA Regulations on Debarment and Suspension.

**CERTIFICATION REGARDING DEBARMENT & SUSPENSION
AND OTHER RESPONSIBILITY MATTERS**

In accordance with the Executive Order 12549, the prospective primary participant certifies to the best of his / her knowledge and belief, that its principals:

- a. Are not presently debarred, suspended, proposed for debarment, declared ineligible, or voluntarily excluded from covered transactions by any federal department or agency;
- b. Have not within a three-year period preceding this proposal been convicted of or had a civil judgment rendered against them for commission of fraud or a criminal offence in connection with obtaining, attempting to obtain, or performing a public (federal, state, or local) transaction or contract under a public transaction; violation of federal or state antitrust statutes or commission of embezzlement, theft, forgery, bribery, falsification or destruction of records, making false statements, or receiving stolen property;
- c. Are not presently indicted for or otherwise criminally or civilly charged by a governmental entity (federal, state, or local) with commission of any of the offenses enumerated in paragraph (1) (b) of this certification.
- d. Have not within a three-year period preceding this application / proposal had one or more public transactions (federal, state, or local) terminated for cause of default.
- e. Acknowledge that all sub-contractors selected for this project must be in compliance with paragraphs (1) (a – d) of this certification.

Name and Title of Authorized Agent

Date

Signature of Authorized Agent

Company Name

_____ I am unable to certify to the above statements. My explanation is attached.

Appendix J

EPA – Prohibition on Certain Telecommunication and Video Surveillance



UNITED STATES ENVIRONMENTAL PROTECTION AGENCY
WASHINGTON, D.C. 20460

OFFICE OF WATER

MEMORANDUM

SUBJECT: Prohibition on Certain Telecommunication and Video Surveillance Services or Equipment in the SRF Programs

FROM: Kiri Anderer, P.E., Acting Associate Branch Chief
Infrastructure Branch, OGWDW

KIRSTEN
ANDERER

Digitally signed by KIRSTEN
ANDERER
Date: 2020.12.11 07:55:52
-05'00'

Michael Deane, Branch Chief
State Revolving Fund Branch, OWM

MICHAEL DEANE

Digitally signed by MICHAEL
DEANE
Date: 2020.12.11 17:56:38 -05'00'

TO: SRF Branch Chiefs
Regions 1-10

Effective August 13, 2020, recipients and subrecipients of EPA funded assistance agreements, including borrowers under EPA funded revolving loan funds, must comply with regulations at [2 CFR 200.216](#), *Prohibition on certain telecommunication and video surveillance services or equipment*, implementing section 889 of [Public Law 115-232](#). The regulation prohibits the use of Federal funds to procure (enter into, extend, or renew contracts) or obtain equipment, systems, or services that use “covered telecommunications equipment or services” identified in the regulation as a substantial or essential component of any system, or as critical technology as part of any system. Prohibitions extend to the use of Federal funds by recipients and subrecipients to enter into a contract with an entity that “uses any equipment, system, or service that uses covered telecommunications equipment or services” as a substantial or essential component of any system, or as critical technology as part of any system. Certain equipment, systems, or services, including equipment, systems, or services produced or provided by entities subject to the prohibition are recorded in the [System for Award Management](#) exclusion list.

As described in section 889 of Public Law 115-232, covered telecommunications equipment or services includes:

- Telecommunications equipment produced by Huawei Technologies Company or ZTE Corporation (or any subsidiary or affiliate of such entities).
- For the purpose of public safety, security of government facilities, physical security surveillance of critical infrastructure, and other national security purposes, video surveillance and telecommunications equipment produced by Hytera Communications Corporation, Hangzhou Hikvision Digital Technology Company, or Dahua Technology Company (or any subsidiary or affiliate of such entities).
- Telecommunications or video surveillance services provided by such entities or using such equipment.

- Telecommunications or video surveillance equipment or services produced or provided by an entity that the Secretary of Defense, in consultation with the Director of the National Intelligence or the Director of the Federal Bureau of Investigation, reasonably believes to be an entity owned or controlled by, or otherwise connected to, the government of a covered foreign country.

Applicability in the State Revolving Fund (SRF) Programs

Clean Water and Drinking Water SRF (CWSRF and DWSRF) programs may not expend equivalency funds for these products on or after August 13, 2020. States must ensure that equivalency assistance agreements include the telecommunications prohibition condition [provided by EPA's Office of Grants and Debarment](#) (OGD) in OGD's most recent EPA General Terms and Conditions. The condition must also be in construction contracts associated with equivalency assistance agreements.

There is no exhaustive list of components and services that fall under the prohibition. State SRF managers and local assistance recipients should exercise due diligence and be particularly mindful of project components with internet or cellular connections. For example, recipients should be mindful of automatic meter reading (AMR) technology and advanced metering infrastructure (AMI), instrumentation control systems (e.g. process control systems, distributed control systems and programmable logic controls), and security cameras and other electronic security measures to ensure that those items are procured from a non-excluded entity. Items included in the prohibition are not eligible SRF costs, and the SRF programs cannot reimburse borrowers for these costs.

The prohibition also applies to the CWSRF administrative funds (if states are billing those costs to the federal CWSRF capitalization grant) and the four DWSRF set-asides. States should be mindful of items such as cell phones, computers, and mobile WiFi routers or hotspots funded by those accounts.

If you have questions on the implementation of this grant condition, please contact Michael Deane at Deane.Michael@epa.gov or Kiri Anderer at Anderer.Kirsten@epa.gov.

Appendix K

EPA General Terms and Conditions

EPA General Terms and Conditions Effective November 12, 2020

1. Introduction

- (a) The recipient and any sub-recipient must comply with the applicable EPA general terms and conditions outlined below. These terms and conditions are in addition to the assurances and certifications made as part of the award and terms, conditions, and restrictions reflected on the official assistance award document. Recipients **must** review their official award document for additional administrative and programmatic requirements. Failure to comply with the general terms and conditions outlined below and those directly reflected on the official assistance award document may result in enforcement actions as outlined in 2 CFR 200.339 and 200.340.
- (b) If the EPA General Terms and Conditions have been revised, EPA will update the terms and conditions when it provides additional funding (incremental or supplemental) prior to the end of the period of performance of this agreement. The recipient must comply with the revised terms and conditions after the effective date of the EPA action that leads to the revision. Revised terms and conditions do not apply to the recipient's expenditures of EPA funds or activities the recipient carries out prior to the effective date of the EPA action. EPA will inform the recipient of revised terms and conditions in the action adding additional funds.

2. Uniform Administrative Requirements, Cost Principles and Audit Requirements for Federal Awards

This award is subject to the requirements of the Uniform Administrative Requirements, Cost Principles and Audit Requirements for Federal Awards; Title 2 CFR, Parts [200](#) and [1500](#). 2 CFR 1500.1, Adoption of 2 CFR Part 200, states Environmental Protection Agency adopts the Office of Management and Budget (OMB) guidance Uniform Administrative Requirements, Cost Principles, and Audit Requirements for Federal Awards to Non-Federal Entities (subparts A through F of 2 CFR Part 200), as supplemented by 2 CFR Part 1500, as the Environmental Protection Agency (EPA) policies and procedures for financial assistance administration. 2 CFR Part 1500 satisfies the requirements of 2 CFR 200.110(a) and gives regulatory effect to the OMB guidance as supplemented by 2 CFR Part 1500. This award is also subject to applicable requirements contained in EPA programmatic regulations located in 40 CFR Chapter 1 Subchapter B.

2.1. Effective Date and Incremental or Supplemental Funding. Consistent with the OMB Frequently Asked Questions at <https://cfo.gov/cofar> on Effective Date and Incremental Funding, any new funding through an amendment (supplemental or incremental) on or after December 26, 2014, and any unobligated balances (defined at 2 CFR 200.1) remaining on the award at the time of the amendment, will be subject to the requirements of the Uniform Administrative Requirements, Cost Principles and Audit Requirements (2 CFR Parts 200 and 1500).

3. Termination

Consistent with 2 CFR 200.340, EPA may unilaterally terminate this award in whole or in part:

- a. if a recipient fails to comply with the terms and conditions of the award including statutory or regulatory requirements; or
- b. if the award no longer effectuates the program goals or agency priorities. Situations in which EPA may terminate an award under this provision include when:
 - (i) EPA obtains evidence that was not considered in making the award that reveals that specific award objective(s) are ineffective at achieving program goals and EPA determines that it is in the government's interest to terminate the award;

(ii) EPA obtains evidence that was not considered in making the award that causes EPA to significantly question the feasibility of the intended objective(s) of the award and EPA determines that it is in the government's interest to terminate the award;

(iii) EPA determines that the objectives of the award are no longer consistent with funding priorities for achieving program goals.

Financial Information

4. Reimbursement Limitation

EPA's financial obligations to the recipient are limited by the amount of federal funding awarded to date as reflected on the award document. If the recipient incurs costs in anticipation of receiving additional funds from EPA, it does so at its own risk. See [2 CFR 1500.9](#).

5. Automated Standard Application Payments (ASAP) and Proper Payment Draw Down

Electronic Payments. Recipients must be enrolled or enroll in the Automated Standard Application for Payments (ASAP) system to receive payments under EPA financial assistance agreements unless:

- EPA grants a recipient-specific exception or the assistance program has received a waiver from this requirement;
- The recipient is exempt from this requirement under [31 CFR 208.4](#); or,
- The recipient is a fellowship recipient pursuant to [40 CFR Part 46](#).

EPA will not make payments to recipients until the ASAP enrollment requirement is met unless the recipients fall under one of the above categories. Recipients may request exceptions using the procedures below but only EPA programs may obtain waivers.

To enroll in ASAP, complete the ASAP Initiate Enrollment form located at:

<https://www.epa.gov/financial/forms> and email it to rtpfc-grants@epa.gov or mail it to:

US Environmental Protection Agency
RTP-Finance Center (Mail Code AA216-01)
4930 Page Rd.
Durham, NC 27711

Under this payment mechanism, the recipient initiates an electronic payment request online via ASAP, which is approved or rejected based on the amount of available funds authorized by EPA in the recipient's ASAP account. Approved payments are credited to the account at the financial institution of the recipient organization set up by the recipient during the ASAP enrollment process. Additional information concerning ASAP and enrollment can be obtained by contacting the EPA Research Triangle Park Finance Center (RTPFC), at rtpfc-grants@epa.gov or 919-541-5347, or by visiting: <https://www.fiscal.treasury.gov/asap/>.

EPA will grant exceptions to the ASAP enrollment requirement only in situations in which the recipient demonstrates to EPA that receiving payment via ASAP places an undue administrative or financial management burden on the recipient or EPA determines that granting the waiver is in the public interest. Recipients may request an exception to the requirement by following the procedures specified in [RAIN-2018-G06-R](#).

Proper Payment Drawdown (for recipients other than states)

- a. As required by [2 CFR 200.305\(b\)](#), the recipient must draw funds from ASAP only for the minimum amounts needed for actual and immediate cash requirements to pay employees, contractors, subrecipients or to satisfy other obligations for allowable costs under this assistance agreement. The timing and amounts of the drawdowns must be as close as administratively feasible to actual disbursements of EPA funds. Disbursement within 5 business days of drawdown will comply with this requirement and the recipient agrees to meet this standard when performing this award.
- b. Recipients may not retain more than 5% of the amount drawn down, or \$1,000 whichever is less, 5 business days after drawdown to materially comply with the standard. Any EPA funds subject to this paragraph that remain undisbursed after 5 business days must be fully disbursed within 15 business days of draw down or be returned to EPA.
- c. If the recipient draws down EPA funds in excess of that allowed by paragraph b., the recipient must contact rtpec-grants@epa.gov for instructions on whether to return the funds to EPA. Recipients must comply with the requirements at [2 CFR 200.305\(b\)\(8\) and \(9\)](#) regarding depositing advances of Federal funds in interest bearing accounts.
- d. Information on how to repay EPA via check is available at <https://www.epa.gov/financial/makepayment>. Instructions on how to return funds to EPA electronically via ASAP are available at <https://www.fiscal.treasury.gov/asap/>
- e. Failure on the part of the recipient to materially comply with this condition may, in addition to EPA recovery of the un-disbursed portions of the drawn down funds, lead to changing the payment method from advance payment to a reimbursable basis. EPA may also take other remedies for noncompliance under [2 CFR 200.208](#) and/or [2 CFR 200.339](#).
- f. If the recipient believes that there are extraordinary circumstances that prevent it from complying with the 5-business day disbursement requirement throughout the performance period of this agreement, recipients may request an exception to the requirement by following the procedures specified in [RAIN-2018-G06-R](#). EPA will grant exceptions to the 5-business day disbursement requirement only if the recipient demonstrates that compliance places an undue administrative or financial management burden or EPA determines that granting the exception is in the public interest.

Selected Items of Cost

6. Prohibition on Certain Telecommunications and Video Surveillance Services or Equipment

This term and condition implements 2 CFR 200.216 and is effective for obligations and expenditures of EPA financial assistance funding on or after 8/13/2020.

As required by 2 CFR 200.216, EPA recipients and subrecipients, including borrowers under EPA funded revolving loan fund programs, are prohibited from obligating or expending loan or grant funds to procure or obtain; extend or renew a contract to procure or obtain; or enter into a contract (or extend or renew a contract) to procure or obtain equipment, services, or systems that use covered telecommunications equipment or services as a substantial or essential component of any system, or as critical technology as part of any system. As described in [Public Law 115-232](#), section 889, covered telecommunications equipment is telecommunications equipment produced by Huawei Technologies Company or ZTE Corporation (or any subsidiary or affiliate of such entities). Recipients, subrecipients, and borrowers also may not use EPA funds to purchase:

- a. For the purpose of public safety, security of government facilities, physical security surveillance of critical

infrastructure, and other national security purposes, video surveillance and telecommunications equipment produced by Hytera Communications Corporation, Hangzhou Hikvision Digital Technology Company, or Dahua Technology Company (or any subsidiary or affiliate of such entities).

- b. Telecommunications or video surveillance services provided by such entities or using such equipment.
- c. Telecommunications or video surveillance equipment or services produced or provided by an entity that the Secretary of Defense, in consultation with the Director of the National Intelligence or the Director of the Federal Bureau of Investigation, reasonably believes to be an entity owned or controlled by, or otherwise connected to, the government of a covered foreign country.

Consistent with 2 CFR 200.471, costs incurred for telecommunications and video surveillance services or equipment such as phones, internet, video surveillance, and cloud servers are allowable except for the following circumstances:

- a. Obligating or expending EPA funds for covered telecommunications and video surveillance services or equipment or services as described in 2 CFR 200.216 to:
 - (1) Procure or obtain, extend or renew a contract to procure or obtain;
 - (2) Enter into a contract (or extend or renew a contract) to procure; or
 - (3) Obtain the equipment, services, or systems.

Certain prohibited equipment, systems, or services, including equipment, systems, or services produced or provided by entities identified in section 889, are recorded in the [System for Award Management](#) exclusion list.

7. Consultant Cap

EPA participation in the salary rate (excluding overhead) paid to individual consultants retained by recipients or by a recipient's contractors or subcontractors shall be limited to the maximum daily rate for a Level IV of the Executive Schedule, available at: <https://www.opm.gov/policy-data-oversight/pay-leave/salaries-wages/>, to be adjusted annually. This limit applies to consultation services of designated individuals with specialized skills who are paid at a daily or hourly rate. This rate does not include transportation and subsistence costs for travel performed (the recipient will pay these in accordance with their normal travel reimbursement practices).

Subagreements with firms for services which are awarded using the procurement requirements in Subpart D of 2 CFR Part 200 are not affected by this limitation unless the terms of the contract provide the recipient with responsibility for the selection, direction and control of the individuals who will be providing services under the contract at an hourly or daily rate of compensation. See [2 CFR 1500.10](#).

8. Establishing and Managing Subawards

If the recipient chooses to pass funds from this assistance agreement to other entities, the recipient must comply with applicable provisions of 2 CFR Part 200 and the EPA Subaward Policy, which may be found at: <https://wcms.epa.gov/grants/grants-policy-issuance-gpi-16-01-epa-subaward-policy-epa-assistance-agreement-recipients>.

As a pass-through entity, the recipient agrees to:

- 1. Be responsible for selecting subrecipients and as appropriate conducting subaward competitions using a system for properly differentiating between subrecipients and procurement contractors under the standards at [2 CFR 200.331](#) and EPA's supplemental guidance in [Appendix A](#) of the [EPA Subaward Policy](#).

- (a) For-profit organizations and individual consultants, in almost all cases, are not eligible

subrecipients under EPA financial assistance programs and the pass-through entity must obtain prior written approval from EPA's Award Official for subawards to these entities unless the EPA-approved budget and work plan for this agreement contain a precise description of such subawards.

(b) Stipends and travel assistance for trainees (including interns) and similar individuals who are not employees of the pass-through entity must be classified as participant support costs rather than subawards as provided in [2 CFR 200.1 Participant support costs](#), [2 CFR 200.1 Subaward](#), and EPA's [Guidance on Participant Support Costs](#).

(c) Subsidies, rebates and similar payments to participants in EPA funded programs to encourage environmental stewardship are also classified as *Participant support costs* as provided in 2 CFR 1500.1 and EPA's [Guidance on Participant Support Costs](#).

2. Establish and follow a system that ensures all subaward agreements are in writing and contain all of the elements required by [2 CFR 200.332\(a\)](#). EPA has developed a template for subaward agreements that is available in [Appendix D](#) of the [EPA Subaward Policy](#).

3. Prior to making subawards, ensure that each subrecipient has a "unique entity identifier." This identifier is required for registering in the [System for Award Management](#) (SAM) and by [2 CFR Part 25](#) and [2 CFR 200.332\(a\)\(1\)](#). The unique entity identifier currently is the subrecipient's Data Universal Numbering System (DUNS) number. Information regarding obtaining a DUNS number and registering in SAM is available in the General Condition of the pass-through entity's agreement with EPA entitled "**Central Contractor Registration/System for Award Management and Universal Identifier Requirements**" T&C of the pass-through entity's agreement with the EPA.

4. Ensure that subrecipients are aware that they are subject to the same requirements as those that apply to the pass-through entity's EPA award as required by [2 CFR 200.332\(a\)\(2\)](#). These requirements include, among others:

(a) Title VI of the Civil Rights Act and other Federal statutes and regulations prohibiting discrimination in Federal financial assistance programs, as applicable.

(b) Reporting Subawards and Executive Compensation under Federal Funding Accountability and Transparency Act (FFATA) set forth in the General Condition pass-through entity's agreement with EPA entitled "**Reporting Subawards and Executive Compensation.**"

(c) Limitations on individual consultant fees as set forth in [2 CFR 1500.10](#) and the General Condition of the pass-through entity's agreement with EPA entitled "**Consultant Fee Cap.**"

(d) EPA's prohibition on paying management fees as set forth in General Condition of the pass-through entity's agreement with EPA entitled "**Management Fees.**"

(e) The Procurement Standards in [2 CFR Part 200](#) including those requiring competition when the subrecipient acquires goods and services from contractors (including consultants).

EPA provides general information on other statutes, regulations and Executive Orders on the [Grants internet site](#) at www.epa.gov/grants. Many Federal requirements are agreement or program specific and EPA encourages pass-through entities to review the terms of their assistance agreement carefully and

consult with their EPA Project Officer for advice if necessary.

5. Ensure, for states and other public recipients, that subawards are not conditioned in a manner that would disadvantage applicants for subawards based on their religious character.

6. Establish and follow a system for evaluating subrecipient risks of noncompliance with Federal statutes, regulations and the terms and conditions of the subaward as required by [2 CFR 200.332](#)(b) and document the evaluation. Risk factors may include:

Prior experience with same or similar subawards;

(a) Results of previous audits;

(b) Whether new or substantially changed personnel or systems, and;

(c) Extent and results of Federal awarding agency or the pass-through entity's monitoring.

7. Establish and follow a process for deciding whether to impose additional requirements on subrecipients based on risk factors as required by [2 CFR 200.332](#)(c). Examples of additional requirements authorized by [2 CFR 200.208](#) include:

(a) Requiring payments as reimbursements rather than advance payments;

(b) Withholding authority to proceed to the next phase until receipt of evidence of acceptable performance within a given period of performance;

(c) Requiring additional, more detailed financial reports;

(d) Requiring additional project monitoring;

(e) Requiring the non-Federal entity to obtain technical or management assistance, and

(f) Establishing additional prior approvals.

8. Establish and follow a system for monitoring subrecipient performance that includes the elements required by [2 CFR 200.331](#)(d) and report the results of the monitoring in performance reports as provided in the reporting terms and conditions of this agreement.

9. Establish and maintain an accounting system which ensures compliance with the \$25,000 limitation at [2 CFR 200.1](#), *Modified Total Direct Costs*, if applicable, on including subaward costs in *Modified Total Direct Costs* for the purposes of distributing indirect costs. Recipients with Federally approved indirect cost rates that use a different basis for distributing indirect costs to subawards must comply with their Indirect Cost Rate Agreement.

10. Work with EPA's Project Officer to obtain the written consent of EPA's Office of International and Tribal Affairs (OITA), prior to awarding a subaward to a foreign or international organization, or a subaward to be performed in a foreign country even if that subaward is described in a proposed scope of work.

11. Obtain written approval from EPA's Award Official for any subawards that are not

described in the approved work plan in accordance with [2 CFR 200.308](#).

12. Obtain the written approval of EPA's Award Official prior to awarding a subaward to an individual if the EPA-approved scope of work does not include a description of subawards to individuals.

13. Establish and follow written procedures under [2 CFR 200.302\(b\)\(7\)](#) for determining that subaward costs are allowable in accordance with [2 CFR Part 200, Subpart E](#) and the terms and conditions of this award. These procedures may provide for allowability determinations on a pre-award basis, through ongoing monitoring of costs that subrecipients incur, or a combination of both approaches provided the pass-through entity documents its determinations.

14. Establish and maintain a system under [2 CFR 200.332\(d\)\(3\)](#) and [2 CFR 200.521](#) for issuing management decisions for audits of subrecipients that relate to Federal awards. However, the recipient remains accountable to EPA for ensuring that unallowable subaward costs initially paid by EPA are reimbursed or mitigated through offset with allowable costs whether the recipient recovers those costs from the subrecipient or not.

15. As provided in [2 CFR 200.333](#), pass-through entities must obtain EPA approval to make fixed amount subawards. EPA is restricting the use of fixed amount subawards to a limited number of situations that are authorized in official EPA pilot projects. Recipients should consult with their EPA Project Officer regarding the status of these pilot projects.

By accepting this award, the recipient is certifying that it either has systems in place to comply with the requirements described in Items 1 through 14 above or will refrain from making subawards until the systems are designed and implemented.

9. Management Fees

Management fees or similar charges in excess of the direct costs and approved indirect rates are not allowable. The term "management fees or similar charges" refers to expenses added to the direct costs in order to accumulate and reserve funds for ongoing business expenses; unforeseen liabilities; or for other similar costs which are not allowable under this assistance agreement. Management fees or similar charges may not be used to improve or expand the project funded under this agreement, except to the extent authorized as a direct cost of carrying out the scope of work.

10. Federal Employee Costs

The recipient understands that none of the funds for this project (including funds contributed by the recipient as cost sharing) may be used to pay for the travel of Federal employees or for other costs associated with Federal participation in this project unless a Federal agency will be providing services to the recipient as authorized by a Federal statute.

11. Foreign Travel

EPA policy requires that all foreign travel must be approved by its Office of International and Tribal Affairs. The recipient agrees to obtain prior EPA approval before using funds available under this agreement for international travel unless the trip(s) are already described in the EPA approved budget for this agreement. Foreign travel includes trips to Mexico and Canada but does not include trips to Puerto Rico, the U.S. Territories or possessions. Recipients that request post-award approval to travel frequently to Mexico and Canada by motor vehicle (e.g. for sampling or meetings) may describe their proposed travel in general terms in their request for EPA approval. Requests for prior approval must be submitted to the Project Officer for this agreement.

12. The Fly America Act and Foreign Travel

The recipient understands that all foreign travel **funded under this assistance agreement** must comply with the Fly America Act. All travel must be on U.S. air carriers certified under 49 U.S.C. Section 40118, to the extent that service by such carriers is available even if foreign air carrier costs are less than the American air carrier.

13. Combating Race and Sex Stereotyping (Added December 9, 2020)

By accepting this award, the recipient certifies that no federal funds awarded, or funds used to satisfy a cost share requirement, for this assistance agreement will be used to promote the concepts (including by conducting research premised upon these concepts) identified in Section 5 of the [Executive Order on Combating Race and Sex Stereotyping](#) issued on September 22, 2020.

Reporting and Additional Post-Award Requirements

14. System for Award Management and Universal Identifier Requirements

- 14.1. Requirement for System for Award Management (SAM)** Unless exempted from this requirement under [2 CFR 25.110](#), the recipient must maintain current information in the SAM. This includes information on the recipient's immediate and highest level owner and subsidiaries, as well as on all the recipient's predecessors that have been awarded a Federal contract or Federal financial assistance within the last three years, if applicable, until the submittal of the final financial report required under this award or receipt of the final payment, whichever is later. This requires that the recipient reviews and updates the information at least annually after the initial registration, and more frequently if required by changes in the information or another award term.
- 14.2. Requirement for Unique Entity Identifier.** If the recipient is authorized to make subawards under this award, the recipient:
- a. Must notify potential subrecipients that no entity (see definition in paragraph 14.3 of this award term) may receive a subaward unless the entity has provided its Unique Entity Identifier.
 - b. May not make a subaward to an entity unless the entity has provided its Unique Entity Identifier. Subrecipients are not required to obtain an active SAM registration, but must obtain a Unique Entity Identifier.
- 14.3. Definitions.** For the purposes of this award term:
- a. **System for Award Management (SAM)** means the Federal repository into which an entity must provide information required for the conduct of business as a recipient. Additional information about registration procedures may be found at the SAM Internet site: <https://www.sam.gov/SAM/>.
 - b. **Unique Entity Identifier** means the identifier assigned by SAM to uniquely identify business entities.
 - c. **Entity** includes non-Federal entities as defined at [2 CFR 200.1](#) and also includes all of the following:
 - 14.3.c.1. A foreign organization;
 - 14.3.c.2. A foreign public entity;
 - 14.3.c.3. A domestic for-profit organization; and
 - 14.3.c.4. A domestic or foreign for-profit organization; and
 - 14.3.c.5. A Federal agency.
 - d. **Subaward** is defined at 2 CFR 200.1.
 - e. **Subrecipient** is defined at 2 CFR 200.1.

15. Reporting Subawards and Executive Compensation

15.1. Reporting of first-tier subawards.

- a. **Applicability.** Unless the recipient is exempt as provided in paragraph 15.4. of this award term, the recipient must report each action that obligates \$30,000 or more in Federal funds for a subaward to a non-Federal entity or Federal agency (see definitions in paragraph 15.5 of this award term).
- b. **Where and when to report.** (1) The recipient must report each obligating action described in paragraph 15.1.a of this award term to www.fsr.gov. (2) For subaward information, report no later than the end of the month following the month in which the obligation was made. (For example, if the obligation was made on any date during the month of November of a given year, the obligation must be reported by no later than December 31 of that year.)
- c. **What to report.** The recipient must report the information about each obligating action as described in the submission instructions available at: <http://www.fsr.gov>.

15.2. Reporting Total Compensation of Recipient Executives.

- a. **Applicability and what to report.** The recipient must report total compensation for each of their five most highly compensated executives for the preceding completed fiscal year, if:
 - 15.2.a.1. the total Federal funding authorized to date under this award is \$30,000 or more;
 - 15.2.a.2. in the preceding fiscal year, the recipient received: (i.) 80 percent or more of their annual gross revenues from Federal procurement contracts (and subcontracts) and Federal financial assistance subject to the Transparency Act, as defined at 2 CFR 170.320 (and subawards); (ii.) and \$25,000,000 or more in annual gross revenues from Federal procurement contracts (and subcontracts) and Federal financial assistance subject to the Transparency Act, as defined at 2 CFR 170.320 (and subawards); and
 - 15.2.a.3. The public does not have access to information about the compensation of the executives through periodic reports filed under section 13(a) or 15(d) of the Securities Exchange Act of 1934 (15 U.S.C. 78m(a), 78o(d)) or section 6104 of the Internal Revenue Code of 1986. (To determine if the public has access to the compensation information, see the U.S. Security and Exchange Commission total compensation filings at: <http://www.sec.gov/answers/excomp.htm>.)
- b. **Where and when to report.** The recipient must report executive total compensation described in paragraph 15.2.a of this award term: (i.) As part of the registration Central System for Award Management profile available at <https://www.sam.gov/SAM/> (ii.) By the end of the month following the month in which this award is made, and annually thereafter.

15.3. Reporting of Total Compensation of Subrecipient Executives.

- a. **Applicability and what to report.** Unless exempt as provided in paragraph 15.4. of this award term, for each first-tier non-Federal entity subrecipient under this award, the recipient shall report the names and total compensation of each of the subrecipient's five most highly compensated executives for the subrecipient's preceding completed fiscal year, if:
 - 15.3.a.1. in the subrecipient's preceding fiscal year, the subrecipient received: (i.) 80 percent or more of its annual gross revenues from Federal procurement contracts (and subcontracts) and Federal financial assistance subject to the Transparency Act, as defined at 2 CFR 170.320 (and subawards); and (ii.) \$25,000,000 or more in annual gross revenues from Federal procurement contracts (and subcontracts), and Federal financial assistance subject to the Transparency Act (and subawards); and
 - 15.3.a.2. The public does not have access to information about the compensation of the executives through periodic reports filed under section 13(a) or 15(d) of the Securities Exchange Act of 1934 (15 U.S.C. 78m(a), 78o(d)) or section 6104 of the Internal Revenue Code of 1986. (To determine if the public has access to the compensation information, see the U.S. Security and

Exchange Commission total compensation filings at:
<http://www.sec.gov/answers/execomp.htm>.)

- b. **Where and when to report.** The recipient must report subrecipient executive total compensation described in paragraph 15.3.a. of this award term:

15.3.b.1. To the recipient.

15.3.b.2. By the end of the month following the month during which the recipient makes the subaward. For example, if a subaward is obligated on any date during the month of October of a given year (i.e., between October 1 and 31), the recipient must report any required compensation information of the subrecipient by November 30 of that year.

15.4. Exemptions

- a. If, in the previous tax year, the recipient had gross income, from all sources, under \$300,000, the recipient is exempt from the requirements to report:

15.4.a.1. (i) subawards, and (ii) the total compensation of the five most highly compensated executives of any subrecipient.

15.5. Definitions. For purposes of this award term:

- a. **Federal agency** means a Federal agency as defined at 5 U.S.C. 551(1) and further clarified by 5 U.S.C 552(f).
- b. **Non-Federal entity** means all of the following, as defined in 2 CFR Part 25: (i.) A Governmental organization, which is a State, local government, or Indian tribe; (ii.) A foreign public entity; (iii.) A domestic or foreign nonprofit organization; and (iv.) A domestic or foreign for-profit organization.
- c. **Executive** means officers, managing partners, or any other employees in management positions.
- d. **Subaward:**
- 15.5.d.1. This term means a legal instrument to provide support for the performance of any portion of the substantive project or program for which you received this award and that you as the recipient award to an eligible subrecipient.
- 15.5.d.2. The term does not include procurement of property and services needed to carry out the project or program (for further explanation, see 2 CFR 200.331).
- 15.5.d.3. A subaward may be provided through any legal agreement, including an agreement that the recipient or a subrecipient considers a contract.
- e. **Subrecipient** means a non-Federal entity or Federal agency that:
- 15.5.e.1. Receives a subaward from the recipient under this award; and
- 15.5.e.2. Is accountable to the recipient for the use of the Federal funds provided by the subaward.
- f. **Total compensation** means the cash and noncash dollar value earned by the executive during the recipient's or subrecipient's preceding fiscal year and includes the following (for more information see 17 CFR 229.402(c)(2)):
- 15.5.f.1. Salary and bonus.
- 15.5.f.2. Awards of stock, stock options and stock appreciation rights. Use the dollar amount recognized for financial statement reporting purposes with respect to the fiscal year in accordance with the Statement of Financial Accounting Standards No. 123 (Revised 2004) (FAS 123R), Shared Based Payments.
- 15.5.f.3. Earnings for services under non-equity incentive plans. This does not include group life, health, hospitalization or medical reimbursement plans that do not discriminate in favor of executives, and are available generally to all salaried employees.
- 15.5.f.4. Change in pension value. This is the change in present value of defined benefit and actuarial pension plans.
- 15.5.f.5. Above-market earnings on deferred compensation which is not tax-qualified.
- 15.5.f.6. Other compensation, if the aggregate value of all such other compensation (e.g. severance, termination payments, value of life insurance paid on behalf of the employee, perquisites or property) for the executive exceeds \$10,000.

16. Recipient Integrity and Performance Matters - Reporting of Matters Related to Recipient Integrity and Performance

16.1. General Reporting Requirement

If the total value of your currently active grants, cooperative agreements, and procurement contracts from all Federal awarding agencies exceeds \$10,000,000 for any period of time during the period of performance of this Federal award, then you as the recipient during that period of time must maintain the currency of information reported to the System for Award Management (SAM) that is made available in the designated integrity and performance system (currently the Federal Awardee Performance and Integrity Information System (FAPIIS)) about civil, criminal, or administrative proceedings described in paragraph 2 of this award term and condition. This is a statutory requirement under section 872 of Public Law 110-417, as amended (41 U.S.C. 2313). As required by section 3010 of Public Law 111-212, all information posted in the designated integrity and performance system on or after April 15, 2011, except past performance reviews required for Federal procurement contracts, will be publicly available.

16.2. Proceedings About Which You Must Report

Submit the information required about each proceeding that:

- a.** Is in connection with the award or performance of a grant, cooperative agreement, or procurement contract from the Federal Government;
- b.** Reached its final disposition during the most recent five-year period; and
- c.** Is one of the following:
 - 16.2.c.1.** A criminal proceeding that resulted in a conviction, as defined in paragraph 5 of this award term and condition;
 - 16.2.c.2.** A civil proceeding that resulted in a finding of fault and liability and payment of a monetary fine, penalty, reimbursement, restitution, or damages of \$5,000 or more;
 - 16.2.c.3.** An administrative proceeding, as defined in paragraph 5. of this award term and condition, that resulted in a finding of fault and liability and your payment of either a monetary fine or penalty of \$5,000 or more or reimbursement, restitution, or damages in excess of \$100,000; or
 - 16.2.c.4.** Any other criminal, civil, or administrative proceeding if:
 - 16.2.c.4.1.** It could have led to an outcome described in paragraph 16.2.c.1, 16.2.c.2, or 16.2.c.3 of this award term and condition;
 - 16.2.c.4.2.** It had a different disposition arrived at by consent or compromise with an acknowledgment of fault on your part; and
 - 16.2.c.4.3.** The requirement in this award term and condition to disclose information about the proceeding does not conflict with applicable laws and regulations.

16.3. Reporting Procedures

Enter in the SAM Entity Management area the information that SAM requires about each proceeding described in paragraph 2 of this award term and condition. You do not need to submit the information a second time under assistance awards that you received if you already provided the information through SAM because you were required to do so under Federal procurement contracts that you were awarded.

16.4. Reporting Frequency

During any period of time when you are subject to the requirement in paragraph 16.1 of this award term and condition, you must report proceedings information through SAM for the most recent five year period, either to report new information about any proceeding(s) that you have not reported previously or affirm that there is no new information to report. Recipients that have Federal contract, grant, and cooperative agreement awards with a cumulative total value greater than \$10,000,000 must disclose semiannually any information about the criminal, civil, and administrative proceedings.

16.5. Definitions

For purposes of this award term and condition:

- a.** Administrative proceeding means a non-judicial process that is adjudicatory in nature in order to make a determination of fault or liability (e.g., Securities and Exchange Commission

Administrative proceedings, Civilian Board of Contract Appeals proceedings, and Armed Services Board of Contract Appeals proceedings). This includes proceedings at the Federal and State level but only in connection with performance of a Federal contract or grant. It does not include audits, site visits, corrective plans, or inspection of deliverables.

b. Conviction, for purposes of this award term and condition, means a judgment or conviction of a criminal offense by any court of competent jurisdiction, whether entered upon a verdict or a plea, and includes a conviction entered upon a plea of nolo contendere.

c. Total value of currently active grants, cooperative agreements, and procurement contracts includes—

16.5.c.1. Only the Federal share of the funding under any Federal award with a recipient cost share or match; and

16.5.c.2. The value of all expected funding increments under a Federal award and options, even if not yet exercised.

17. Federal Financial Reporting (FFR)

Pursuant to [2 CFR 200.328](#) and [2 CFR 200.344](#), EPA recipients must submit the Federal Financial Report (SF-425) at least annually and no more frequently than quarterly. EPA's standard reporting frequency is annual unless an EPA Region has included an additional term and condition specifying greater reporting frequency within this award document. EPA recipients must submit the SF-425 no later than 30 calendar days after the end of each specified reporting period for quarterly and semi-annual reports and 90 calendar days for annual reports. Final reports are due no later than 120 calendar days after the end date of the period of performance of the award. Extension of reporting due dates may be approved by EPA when requested and justified by the recipient. The FFR form is available on the internet at: <https://www.epa.gov/financial/forms>. All FFRs must be submitted to the Research Triangle Park Finance Center (RTPFC) via email at rtpfc-grants@epa.gov or mail it to:

US Environmental Protection Agency
RTP-Finance Center (Mail Code AA216-01)
4930 Page Rd.
Durham, NC 27703

The RTPFC will make adjustments, as necessary, to obligated funds after reviewing and accepting a final Federal Financial Report. Recipients will be notified and instructed by EPA if they must complete any additional forms for the closeout of the assistance agreement.

18. Indirect Cost Rate Agreements

This term and condition provides requirements for recipients using EPA funds for indirect costs and applies to all EPA assistance agreements unless there are [statutory or regulatory limits on IDCs](#). See also [EPA's Indirect Cost Policy for Recipients of EPA Assistance Agreements](#) (IDC Policy).

In order for the assistance agreement recipient to use EPA funding for indirect costs, the IDC category of the recipient's assistance agreement award budget must include an amount for IDCs and at least one of the following must apply:

- With the exception of "exempt" agencies and Institutions of Higher Education as noted below, all recipients must have one of the following current (not expired) IDC rates, including IDC rates that have been extended by the cognizant agency:
 - Provisional;
 - Final;
 - Fixed rate with carry-forward;
 - Predetermined;

- 10% *de minimis* rate authorized by [2 CFR 200.414\(f\)](#)
- EPA-approved use of an expired fixed rate with carry-forward on an exception basis, as detailed in section 6.4.a. of the IDC Policy.
- “Exempt” state or local governmental departments or agencies are agencies that receive up to and including \$35,000,000 in Federal funding per the department or agency’s fiscal year, and must have an IDC rate proposal developed in accordance with 2 CFR Part 200, Appendix VII, with documentation maintained and available for audit.
- Institutions of Higher Education must use the IDC rate in place at the time of award for the life of the assistance agreement (unless the rate was provisional at time of award, in which case the rate will change once it becomes final). As provided by 2 CFR Part 200, Appendix III(C)(7), the term “life of the assistance agreement”, means each competitive segment of the project. Additional information is available in the regulation.

IDCs incurred during any period of the assistance agreement that are not covered by the provisions above are not allowable costs and must not be drawn down by the recipient. Recipients may budget for IDCs if they have submitted a proposed IDC rate to their cognizant Federal agency or requested an exception from EPA under subsection 6.4 of the IDC Policy. However, recipients may not draw down IDCs until their rate is approved, if applicable, or EPA grants an exception. IDC drawdowns must comply with the indirect rate corresponding to the period during which the costs were incurred.

This term and condition does not govern indirect rates for subrecipients or recipient procurement contractors under EPA assistance agreements. Pass-through entities are required to comply with [2 CFR 200.332\(a\)\(4\)\(i\)](#) and (ii) when establishing indirect cost rates for subawards.

19. Audit Requirements

In accordance with [2 CFR 200.501\(a\)](#), the recipient hereby agrees to obtain a single audit from an independent auditor, if their organization expends \$750,000 or more in total Federal funds in their fiscal year beginning on or after December 26, 2014.

The recipient must submit the form SF-SAC and a Single Audit Report Package within 9 months of the end of the recipient’s fiscal year or 30 days after receiving the report from an independent auditor. The SF-SAC and a Single Audit Report Package MUST be submitted using the Federal Audit Clearinghouse’s Internet Data Entry System available at: <https://facides.census.gov/>

For complete information on how to accomplish the single audit submissions, you will need to visit the Federal Audit Clearinghouse Web site: <https://facweb.census.gov/>

20. Closeout Requirements

Reports required for closeout of the assistance agreement must be submitted in accordance with this agreement. Submission requirements and frequently asked questions can also be found at:

<https://www.epa.gov/grants/frequent-questions-about-closeouts>

21. Suspension and Debarment

Recipient shall fully comply with Subpart C of 2 C.F.R. Part 180 entitled, “Responsibilities of Participants Regarding Transactions Doing Business With Other Persons,” as implemented and supplemented by 2 C.F.R. Part 1532. Recipient is responsible for ensuring that any lower tier covered transaction, as described in Subpart B of 2 C.F.R. Part 180, entitled “Covered Transactions,” and 2 C.F.R. § 1532.220, includes a term or condition requiring compliance with 2 C.F.R. Part 180, Subpart C. Recipient is responsible for further requiring the inclusion of a similar term and condition in any subsequent lower tier covered transactions. Recipient acknowledges that failing to disclose the information required under 2 C.F.R. § 180.335 to the EPA office that is entering into the transaction with the recipient may result in the delay or negation of this assistance agreement, or pursuance of administrative remedies, including suspension and debarment. Recipients may access the

System for Award Management (SAM) exclusion list at <https://sam.gov/SAM/> to determine whether an entity or individual is presently excluded or disqualified.

22. Representation by Corporations Regarding Delinquent Tax Liability or a Felony Conviction under any Federal Law.

This award is subject to the provisions contained in an appropriations act(s) which prohibits the Federal Government from entering into a contract, memorandum of understanding, or cooperative agreement with, make a grant to, or provide a loan or loan guarantee to any corporation having a delinquent Federal tax liability or a felony conviction under any Federal law, unless the agency has considered suspension or debarment of the corporation and has made a determination that this further action is not necessary to protect the interests of the Government. A “corporation” is a legal entity that is separate and distinct from the entities that own, manage, or control it. It is organized and incorporated under the jurisdictional authority of a governmental body, such as a State or the District of Columbia. A corporation may be a for-profit or non-profit organization.

As required by the appropriations act(s) prohibitions, the Government will not enter into a contract, memorandum of understanding, or cooperative agreement with, make a grant to, or provide a loan or loan guarantee with any corporation that — (1) Has any unpaid Federal tax liability that has been assessed, for which all judicial and administrative remedies have been exhausted or have lapsed, and that is not being paid in a timely manner pursuant to an agreement with the authority responsible for collecting the tax liability, where the awarding agency is aware of the unpaid tax liability, unless an agency has considered suspension or debarment of the corporation and made a determination that suspension or debarment is not necessary to protect the interests of the Government; or (2) Was convicted of a felony criminal violation under any Federal law within the preceding 24 months, where the awarding agency is aware of the conviction, unless an agency has considered suspension or debarment of the corporation and made a determination that this action is not necessary to protect the interests of the Government.

By accepting this award, the recipient represents that it is not a corporation that has any unpaid Federal tax liability that has been assessed, for which all judicial and administrative remedies have been exhausted or have lapsed, and that is not being paid in a timely manner pursuant to an agreement with the authority responsible for collecting the tax liability; and it is not a corporation that was convicted of a felony criminal violation under a Federal law within the preceding 24 months.

Alternatively, by accepting this award, the recipient represents that it disclosed unpaid Federal tax liability information and/or Federal felony conviction information to the EPA. The Recipient may accept this award if the EPA Suspension and Debarment Official has considered suspension or debarment of the corporation based on a tax liabilities and/or Federal felony convictions and determined that suspension or debarment is not necessary to protect the Government's interests.

If the recipient fails to comply with this term and condition, EPA will annul this agreement and may recover any funds the recipient has expended in violation of the appropriations act(s) prohibition(s). The EPA may also pursue other administrative remedies as outlined in [2 CFR 200.339](#) and [2 CFR 200.340](#), and may also pursue suspension and debarment.

23. Disclosing Conflict of Interests

23.1. For awards to Non-federal entities and individuals (other than states and fellowship recipients under 40 CFR Part 46).

As required by 2 CFR 200.112, EPA has established a policy (COI Policy) for disclosure of conflicts of interest (COI) that may affect EPA financial assistance awards. EPA's COI Policy is posted at <https://www.epa.gov/grants/epas-financial-assistance-conflict-interest-policy>. The posted version of EPA's COI Policy is applicable to new funding (initial awards, supplemental and incremental funding) awarded on or after October 1, 2015. This COI term

and condition supersedes prior COI terms and conditions for this award based on either EPA's May 22, 2015 Revised Interim COI Policy or December 26, 2014 Interim COI Policy.

For competitive awards, recipients must disclose any competition related COI described in section 4.0(a) of the COI Policy that are discovered after award to the EPA Grants Specialist listed on the Assistance Agreement/Amendment within 30 calendar days of discovery of the COI. The Grants Specialist will respond to any such disclosure within 30 calendar days.

EPA's COI Policy requires that recipients have systems in place to address, resolve and disclose to EPA COIs described in sections 4.0(b), (c) and/or (d) of the COI Policy that affect any contract or subaward regardless of amount funded under this award. The recipient's COI Point of Contact for the award must disclose any COI to the EPA Grants Specialist listed on the Assistance Agreement/Amendment within 30 calendar days of the discovery of the potential COI and their approach for resolving the COI.

EPA's COI Policy requires that subrecipients have systems in place to address, resolve and disclose COI's described in section 4.0(b)(c) and (d) of the COI Policy regardless of the amount of the transaction. Recipients who are pass-through entities as defined at 2 CFR 200.1 must require that subrecipients being considered for or receiving subawards disclose COI to the pass-through entities in a manner that, at a minimum, is in accordance with sections 5.0(d) and 7.0(c) of EPA's COI Policy. Pass-through entities must disclose the subrecipient COI along with the approach for resolving the COI to the EPA Grants Specialist listed on the Assistance Agreement/Amendment within 30 calendar days of receiving notification of the COI by the subrecipient.

EPA only requires that recipients and subrecipients disclose COI's that are discovered under their systems for addressing and resolving COI. If recipients or subrecipients do not discover a COI, they do not need to advise EPA or the pass-through entity of the absence of a COI.

Upon notice from the recipient of a potential COI and the approach for resolving it, the Agency will then make a determination regarding the effectiveness of these measures within 30 days of receipt of the recipient's notice unless a longer period is necessary due to the complexity of the matter. Recipients may not request payment from EPA for costs for transactions subject to the COI pending notification of EPA's determination. Failure to disclose a COI may result in cost disallowances.

Disclosure of a potential COI will not necessarily result in EPA disallowing costs, with the exception of procurement contracts that the Agency determines violate 2 CFR 200.318(c)(1) or (2), provided the recipient notifies EPA of measures the recipient or subrecipient has taken to eliminate, neutralize or mitigate the conflict of interest when making the disclosure.

23.2. For awards to states including state universities that are state agencies or instrumentalities

As required by 2 CFR 200.112, EPA has established a policy (COI Policy) for disclosure of conflicts of interest (COI) that may affect EPA financial assistance awards. EPA's COI Policy is posted at: <https://www.epa.gov/grants/epas-financial-assistance-conflict-interest-policy>. The posted version of EPA's COI Policy is applicable to new funding (initial awards, supplemental, incremental funding) awarded on or after October 1, 2015. This COI term and condition supersedes prior COI terms and conditions for this award based on either EPA's May 22, 2015 Revised Interim COI Policy or December 26, 2014 Interim COI Policy.

For competitive awards, recipients must disclose any competition related COI described in section 4.0(a)

of the COI Policy that are discovered after award to the EPA Grants Specialist listed on the Assistance Agreement/Amendment within 30 calendar days of discovery of the COI. The Grants Specialist will respond to any such disclosure within 30 calendar days.

States including state universities that are state agencies and instrumentalities receiving funding from EPA are only required to disclose subrecipient COI as a pass-through entity as defined by 2 CFR 200.1. Any other COI are subject to state laws, regulations and policies. EPA's COI Policy requires that subrecipients have systems in place to address, resolve and disclose COIs described in section 4.0(b)(c) and (d) of the COI Policy that arise after EPA made the award regardless of the amount of the transaction. States who are pass-through entities as defined at 2 CFR 200.1 must require that subrecipients being considered for or receiving subawards disclose COI to the state in a manner that, as a minimum, in accordance with sections 5.0(d) and 7.0(c) of EPA's COI Policy. States must disclose the subrecipient COI along with the approach for resolving the COI to the EPA Grants Specialist listed on the Assistance Agreement/Amendment within 30 calendar days of receiving notification of the COI by the subrecipient.

EPA only requires that subrecipients disclose COI's to state pass-through entities that are discovered under their systems for addressing, resolving, and disclosing COI. If subrecipients do not discover a COI, they do not need to advise state pass-through entities of the absence of a COI.

Upon receiving notice of a potential COI and the approach for resolving it, the Agency will make a determination regarding the effectiveness of these measures within 30 days of receipt of the state's notice of a subrecipient COI unless a longer period is necessary due to the complexity of the matter. States may not request payment from EPA for costs for transactions subject to the COI pending notification of EPA's determination. A subrecipient's failure to disclose a COI to the state and EPA may result in cost disallowances.

Disclosure of a potential subrecipient COI will not necessarily result in EPA disallowing costs, with the exception of procurement contracts that the Agency determines violate 2 CFR 200.318(c)(1) or (2), provided the subrecipient has taken measures that EPA and the state agree eliminate, neutralize or mitigate the conflict of interest.

24. Transfer of Funds

Applicable to all assistance agreements other than Continuing Environmental Program Grants subject to 40 CFR 35.114 and 40 CFR 35.514 when EPA's share of the total project costs exceeds the Simplified Acquisition Threshold. Simplified Acquisition Threshold is defined at 2 CFR 200.1 and is currently set at \$250,000 but the amount is subject to adjustment.

(1) As provided at 2 CFR 200.308(f), the recipient must obtain prior approval from EPA's Grants Management Officer if the cumulative amount of funding transfers among direct budget categories or programs, functions and activities exceeds 10% of the total budget. Recipients must submit requests for prior approval to the Grant Specialist and Grants Management Officer with a copy to the Project Officer for this agreement.

(2) Recipients must notify EPA's Grant Specialist and Project Officer of cumulative funding transfers among direct budget categories or programs, functions and activities that do not exceed 10% of the total budget for the agreement. Recipients must also notify the EPA Grant Specialist and Project Officer when transferring funds from direct budget categories to the indirect cost category or from the indirect cost category to the direct cost category. Prior approval by EPA's Grant Management Officer is required if the transfer involves any of the items listed in 2 CFR 200.407 that EPA did not previously approve at time of award or in response to a previous post-award request by the recipient.

Applicable to Continuing Environmental Program Grants subject to 40 CFR 35.114 and 40 CFR 35.514. when EPA's share of the total project costs exceeds the Simplified Acquisition Threshold. Simplified Acquisition Threshold is defined at 2 CFR 200.1 and is currently set at \$250,000 but the amount is subject to adjustment.

Recipients of continuing environmental program grants subject to 40 CFR 35.114 and 40 CFR 35.514 must notify the EPA Grant Specialist and Project Officer of funding transfers among direct budget categories, programs, functions and activities or transfers that change amounts budgeted for indirect costs, but prior EPA approval is not required unless the transfer results in significant changes to work plan commitments. Recipients must obtain prior written approval if the transfer involves any of the items listed in 2 CFR 200.407 that EPA did not previously approve at time of award, in response to a previous post-award request by the recipient, or is subject to an EPA waiver of prior approval under 40 CFR 35.114(d) or 40 CFR 35.514(d).

25. Electronic/Digital Signatures on Financial Assistance Agreement Form(s)/Document(s)

Throughout the life of this assistance agreement, the recipient agrees to ensure that any form(s)/document(s) required to be signed by the recipient and submitted to EPA through any means including but not limited to hard copy via U.S. mail or express mail, hand delivery or through electronic means such as e-mail are: (1) signed by the individual identified on the form/document, and (2) the signer has the authority to sign the form/document for the recipient. Submission of any signed form(s)/document(s) is subject to any provisions of law on making false statements (e.g. 18 U.S.C. 1001).

26. Extension of Project/Budget Period Expiration Date

EPA has not exercised the waiver option to allow automatic one-time extensions for non-research grants under [2 CFR 200.308\(e\)\(2\)](#). Therefore, if a no-cost time extension is necessary to extend the period of availability of funds, the recipient must submit a written request to the EPA prior to the budget/project period expiration dates. **The written request must include:** a justification describing the need for additional time, an estimated date of completion, and a revised schedule for project completion including updated milestone target dates for the approved workplan activities. In addition, if there are overdue reports required by the general, administrative, and/or programmatic terms and conditions of this assistance agreement, the recipient must ensure that they are submitted along with or prior to submitting the no-cost time extension request.

27. Utilization of Disadvantaged Business Enterprises

GENERAL COMPLIANCE, 40 CFR, Part 33

The recipient agrees to comply with the requirements of EPA's Disadvantaged Business Enterprise (DBE) Program for procurement activities under assistance agreements, contained in 40 CFR, Part 33.

The following text either provides updates to 40 CFR, Part 33 based upon the associated class exception or highlights a requirement.

1. EPA MBE/WBE CERTIFICATION, 40 CFR, Part 33, Subpart B

EPA no longer certifies entities as Minority-Owned Business Entities (MBEs) or Women-Owned Business Entities (WBEs) pursuant to a class exception issued in October 2019. The class exception was authorized pursuant to the authority in 2 CFR, Section 1500.3(b).

2. SIX GOOD FAITH EFFORTS, 40 CFR, Part 33, Subpart C

Pursuant to 40 CFR Section 33.301, the recipient agrees to make good faith efforts whenever procuring construction, equipment, services and supplies under an EPA financial assistance agreement, and to require that sub-recipients, loan recipients, and prime contractors also comply. Records documenting compliance with the six good faith efforts shall be retained. The specific six good faith efforts can be found at: [40 CFR Section 33.301 \(a\)-\(f\)](#).

However, in EPA assistance agreements that are for the benefit of Native Americans, the recipient must solicit and recruit Native American organizations and Native American-owned economic enterprises and give them preference in the award process prior to undertaking the six good faith efforts ([40 CFR Section 33.304](#)). If recruiting efforts are unsuccessful, the recipient must follow the six good faith efforts.

3. CONTRACT ADMINISTRATION PROVISIONS, 40 CFR Section 33.302

The recipient agrees to comply with the contract administration provisions of [40 CFR Section 33.302](#) (a)-(d) and (i).

4. BIDDERS LIST, 40 CFR Section 33.501(b) and (c)

Recipients of a Continuing Environmental Program Grant or other annual reporting grant, agree to create and maintain a bidders list. Recipients of an EPA financial assistance agreement to capitalize a revolving loan fund also agree to require entities receiving identified loans to create and maintain a bidders list if the recipient of the loan is subject to, or chooses to follow, competitive bidding requirements. Please see 40 CFR Section 33.501 (b) and (c) for specific requirements and exemptions.

5. FAIR SHARE OBJECTIVES, 40 CFR, Part 33, Subpart D

In October 2019, a class exception to the entire Subpart D of 40 CFR, Part 33 has been authorized pursuant to the authority in 2 CFR Section 1500.3(b). Notwithstanding Subpart D of 40 CFR, Part 33, recipients are not required to negotiate or apply fair share objectives in procurements under assistance agreements.

6. MBE/WBE REPORTING, 40 CFR, Part 33, Subpart E

When required, the recipient agrees to complete and submit a “MBE/WBE Utilization Under Federal Grants and Cooperative Agreements” report (EPA Form 5700-52A) on an annual basis. The current EPA Form 5700-52A can be found at the EPA Grantee Forms Page at https://www.epa.gov/sites/production/files/2020-06/documents/epa_form_5700_52a_fill-sign.pdf.

Reporting is required for assistance agreements where funds are budgeted for procuring construction, equipment, services and supplies (including funds budgeted for direct procurement by the recipient or procurement under subawards or loans in the “Other” category) with a cumulative total that exceed the Simplified Acquisition Threshold (SAT) (currently, \$250,000 however the threshold will be automatically revised whenever the SAT is adjusted; See 2 CFR Section 200.1), including amendments and/or modifications. When reporting is required, all procurement actions are reportable, not just the portion which exceeds the SAT.

Annual reports are due by October 30th of each year. Final reports are due 120 days after the end of the project period.

This provision represents an approved exception from the MBE/WBE reporting requirements as described in 40 CFR Section 33.502.

7. MBE/WBE RECORDKEEPING, 40 CFR, Part 33, Subpart E

The recipient agrees to comply with all recordkeeping requirements as stipulated in 40 CFR, Part 33, Subpart E including creating and maintaining a bidders list, when required. Any document created as a record to demonstrate compliance with any requirement of 40 CFR, Part 33 must be maintained pursuant to the requirements stated in this Subpart.

Programmatic General Terms and Conditions

28. Sufficient Progress

EPA will measure sufficient progress by examining the performance required under the workplan in conjunction with the milestone schedule, the time remaining for performance within the project period and/or the availability of funds necessary to complete the project. EPA may terminate the assistance agreement for failure to ensure reasonable completion of the project within the project period.

29. Copyrighted Material and Data

In accordance with [2 CFR 200.315](#), EPA has the right to reproduce, publish, use and authorize others to reproduce, publish and use copyrighted works or other data developed under this assistance agreement for Federal purposes.

Examples of a Federal purpose include but are not limited to: (1) Use by EPA and other Federal employees for official Government purposes; (2) Use by Federal contractors performing specific tasks for [i.e., authorized by] the Government; (3) Publication in EPA documents provided the document does not disclose trade secrets (e.g. software codes) and the work is properly attributed to the recipient through citation or otherwise; (4) Reproduction of documents for inclusion in Federal depositories; (5) Use by State, tribal and local governments that carry out delegated Federal environmental programs as “co-regulators” or act as official partners with EPA to carry out a national environmental program within their jurisdiction and; (6) Limited use by other grantees to carry out Federal grants provided the use is consistent with the terms of EPA’s authorization to the other grantee to use the copyrighted works or other data.

Under Item 6, the grantee acknowledges that EPA may authorize another grantee(s) to use the copyrighted works or other data developed under this grant as a result of:

- the selection of another grantee by EPA to perform a project that will involve the use of the copyrighted works or other data or;
- termination or expiration of this agreement.

In addition, EPA may authorize another grantee to use copyrighted works or other data developed with Agency funds provided under this grant to perform another grant when such use promotes efficient and effective use of Federal grant funds.

30. Patents and Inventions

Rights to inventions made under this assistance agreement are subject to federal patent and licensing regulations, which are codified at Title 37 CFR Part 401 and Title 35 USC Sections 200-212.

Pursuant to the Bayh-Dole Act (set forth in 35 USC 200-212), EPA retains the right to a worldwide, nonexclusive, nontransferable, irrevocable, paid-up license to practice the invention owned by the assistance agreement holder, as defined in the Act. To streamline the invention reporting process and to facilitate compliance with the Bayh-Dole Act, the recipient must utilize the Interagency Edison extramural invention reporting system at [iEdison.gov](#). Annual utilization reports must be submitted through the system. The recipient is required to notify the Project Officer identified on the award document when an invention report, patent report, or utilization report is filed at [iEdison.gov](#). EPA elects not to require the recipient to provide a report prior to the close-out of a funding agreement listing all subject inventions or stating that there were none.

In accordance with Executive Order 12591, as amended, government owned and operated laboratories can enter into cooperative research and development agreements with other federal laboratories, state and local governments, universities, and the private sector, and license, assign, or waive rights to intellectual property “developed by the laboratory either under such cooperative research or development agreements and from within individual laboratories.”

31. Acknowledgement Requirements for Non-ORD Assistance Agreements

The recipient agrees that any reports, documents, publications or other materials developed for public distribution supported by this assistance agreement shall contain the following statement:

"This project has been funded wholly or in part by the United States Environmental Protection Agency under assistance agreement (number) to (recipient). The contents of this document do not necessarily reflect the views and policies of the Environmental Protection Agency, nor does the EPA endorse trade names or recommend the use of commercial products mentioned in this document."

Recipients of EPA Office of Research Development (ORD) research awards must follow the acknowledgement requirements outlined in the research T&Cs available at: <https://www.nsf.gov/awards/managing/rtc.jsp>. A Federal-wide workgroup is currently updating the Federal-Wide Research Terms and Conditions Overlay to the Uniform Administrative Requirements, Cost Principles and Audit Requirements for Federal Awards and when completed recipients of EPA ORD research must abide by the research T&Cs.

32. Electronic and Information Technology Accessibility

Recipients are subject to the program accessibility provisions of Section 504 of the Rehabilitation Act, codified in 40 CFR Part 7, which includes an obligation to provide individuals with disabilities reasonable accommodations and an equal and effective opportunity to benefit from or participate in a program, including those offered through electronic and information technology ("EIT"). In compliance with Section 504, EIT systems or products funded by this award must be designed to meet the diverse needs of users (e.g., U.S. public, recipient personnel) without barriers or diminished function or quality. Systems shall include usability features or functions that accommodate the needs of persons with disabilities, including those who use assistive technology. At this time, the EPA will consider a recipient's websites, interactive tools, and other EIT as being in compliance with Section 504 if such technologies meet standards established under Section 508 of the Rehabilitation Act, codified at 36 CFR Part 1194. While Section 508 does not apply directly to grant recipients, we encourage recipients to follow either the 508 guidelines or other comparable guidelines that concern accessibility to EIT for individuals with disabilities.

Recipients may wish to consult the latest Section 508 guidelines issued by the U.S. Access Board or W3C's Web Content Accessibility Guidelines (WCAG) 2.0 (see <https://www.access-board.gov/guidelines-and-standards/communications-and-it/about-the-section-508-standards/guide-to-the-section-508-standards>).

33. Human Subjects

Human subjects research is any activity that meets the regulatory definitions of both research AND human subject. *Research* is a systematic investigation, including research development, testing and evaluation, designed to develop or contribute to generalizable knowledge. *Human subject* means a living individual about whom an investigator (whether professional or student) conducting research obtains (1) data through intervention or interaction with the individual, or (2) identifiable private information. [40 CFR 26.102 (d)(f)]

No research involving human subjects will be conducted under this agreement without prior written approval of the EPA to proceed with that research. If engaged in human subjects research as part of this agreement, the recipient agrees to comply with all applicable provisions of EPA Regulation 40 CFR 26 (Protection of Human Subjects). This includes, at Subpart A, the Basic Federal Policy for the Protection of Human Research Subjects, also known as the Common Rule. It also includes, at Subparts B, C, and D, prohibitions and additional protections for children, nursing women, pregnant women, and fetuses in research conducted or supported by EPA.

The recipient further agrees to comply with EPA's procedures for oversight of the recipient's compliance with 40 CFR 26, as given in EPA Order 1000.17 Change A1 (Policy and Procedures on Protection of Human Research Subjects in EPA Conducted or Supported Research). As per this order, no human subject may be involved in any research conducted under this assistance agreement, including recruitment, until the research

has been approved or determined to be exempt by the EPA Human Subjects Research Review Official (HSRRO) after review of the approval or exemption determination of the Institutional Review Board(s) (IRB(s)) with jurisdiction over the research under 40 CFR 26.

For HSRRO approval, the recipient must forward to the Project Officer: (1) copies of all documents upon which the IRB(s) with jurisdiction based their approval(s) or exemption determination(s), (2) copies of the IRB approval or exemption determination letter(s), (3) copy of the IRB-approved consent forms and subject recruitment materials, if applicable, and (4) copies of all supplementary IRB correspondence.

Following the initial approvals indicated above, the recipient must, as part of the annual report(s), provide evidence of continuing review and approval of the research by the IRB(s) with jurisdiction, as required by 40 CFR 26.109(e). Materials submitted to the IRB(s) for their continuing review and approval are to be provided to the Project Officer upon IRB approval. During the course of the research, investigators must promptly report any unanticipated problems involving risk to subjects or others according to requirements set forth by the IRB. In addition, any event that is significant enough to result in the removal of the subject from the study should also be reported to the Project Officer, even if the event is not reportable to the IRB of record.

34. Animal Subjects

The recipient agrees to comply with the Animal Welfare Act of 1966 (P.L. 89-544), as amended, 7 USC 2131-2156. Recipient also agrees to abide by the "U.S. Government Principles for the Utilization and Care of Vertebrate Animals used in Testing, Research, and Training." (Federal Register 50(97): 20864-20865. May 20,1985). The nine principles can be viewed at <https://olaw.nih.gov/policies-laws/phs-policy.htm>. For additional information about the Principles, the recipient should consult the *Guide for Care and Use of Laboratory Animals*, prepared by the Institute of Laboratory Animal Resources, National Research Council and can be accessed at: <http://www.nap.edu/readingroom/books/labrats/>.

35. Light Refreshments and/or Meals

APPLICABLE TO ALL AGREEMENTS EXCEPT STATE CONTINUING ENVIRONMENTAL PROGRAMS (AS DESCRIBED BELOW):

Unless the event(s) and all of its components are described in the approved workplan, the recipient agrees to obtain prior approval from EPA for the use of grant funds for light refreshments and/or meals served at meetings, conferences, training workshops and outreach activities (events). The recipient must send requests for approval to the EPA Project Officer and include:

- (1) An estimated budget and description for the light refreshments, meals, and/or beverages to be served at the event(s);
- (2) A description of the purpose, agenda, location, length and timing for the event; and,
- (3) An estimated number of participants in the event and a description of their roles.

Costs for light refreshments and meals for recipient staff meetings and similar day-to-day activities are not allowable under EPA assistance agreements.

Recipients may address questions about whether costs for light refreshments, and meals for events may be allowable to the recipient's EPA Project Officer; however, the Agency Award Official or Grant Management Officer will make final determinations on allowability. Agency policy prohibits the use of EPA funds for receptions, banquets and similar activities that take place after normal business hours unless the recipient has provided a justification that has been expressly approved by EPA's Award Official or Grants Management Officer.

EPA funding for meals, light refreshments, and space rental may not be used for any portion of an event where alcohol is served, purchased, or otherwise available as part of the event or meeting, even if EPA funds are not

used to purchase the alcohol.

Note: U.S. General Services Administration regulations define light refreshments for morning, afternoon or evening breaks to include, but not be limited to, coffee, tea, milk, juice, soft drinks, donuts, bagels, fruit, pretzels, cookies, chips, or muffins. (41 CFR 301-74.7)

FOR STATE CONTINUING ENVIRONMENTAL PROGRAM GRANT RECIPIENTS EXCLUDING STATE UNIVERSITIES:

If the state maintains systems capable of complying with federal grant regulations at 2 CFR 200.432 and 200.438, EPA has waived the prior approval requirements for the use of EPA funds for light refreshments and/or meals served at meetings, conferences, and training, as described above. The state may follow its own procedures without requesting prior approval from EPA. However, notwithstanding state policies, EPA funds may not be used for (1) evening receptions, or (2) other evening events (with the exception of working meetings). Examples of working meetings include those evening events in which small groups discuss technical subjects on the basis of a structured agenda or there are presentations being conducted by experts. EPA funds for meals, light refreshments, and space rental may not be used for any portion of an event (including evening working meetings) where alcohol is served, purchased, or otherwise available as part of the event or meeting, even if EPA funds are not used to purchase the alcohol.

By accepting this award, the state is certifying that it has systems in place (including internal controls) to comply with the requirements described above.

36. Tangible Personal Property

36.1 Reporting Pursuant to 2 CFR 200.312 and 200.314, property reports, if applicable, are required for Federally-owned property in the custody of a non-Federal entity upon completion of the Federal award or when the property is no longer needed. Additionally, upon termination or completion of the project, residual unused supplies with a total aggregate fair market value exceeding \$5,000 not needed for any other Federally-sponsored programs or projects must be reported. For Superfund awards under Subpart O, refer to 40 CFR 35.6340 and 35.6660 for property reporting requirements. Recipients should utilize the Tangible Personal Property Report form series (SF-428) to report tangible personal property.

36.2 Disposition

- 36.2.1 Most Recipients.** Consistent with 2 CFR 200.313, unless instructed otherwise on the official award document, this award term, or at closeout, the recipient may keep the equipment and continue to use it on the project originally funded through this assistance agreement or on other federally funded projects whether or not the project or program continues to be supported by Federal funds.
- 36.2.2 State Agencies.** Per 2 CFR 200.313(b), state agencies may manage and dispose of equipment acquired under this assistance agreement in accordance with state laws and procedures.
- 36.2.3 Superfund Recipients.** Equipment purchased under Superfund projects is subject to specific disposal options in accordance with 40 CFR Part 35.6345.

37. Dual Use Research of Concern (DURC)

The recipient agrees to conduct all life science research* in compliance with [EPA's Order on the Policy and Procedures for Managing Dual Use Research of Concern](#) (EPA DURC Order) and [United States Government Policy for Institutional Oversight of Life Sciences Dual Use Research of Concern \(iDURC Policy\)](#). If the recipient is an institution within the United States that receives funding through this agreement, or from any other source, the recipient agrees to comply with the iDURC Policy if they conduct or sponsor research involving any of the agents or toxins identified in Section 6.2.1 of the iDURC Policy. If the institution is outside the United States and receives funding through this agreement to conduct or sponsor research involving any of those same agents or toxins, the recipient agrees to comply with the iDURC Policy. The recipient agrees to provide any additional information that may be requested by EPA regarding DURC and iDURC. The recipient

agrees to immediately notify the EPA Project Officer should the project use or introduce use of any of the agents or toxins identified in the iDURC Policy. The recipient's Institution/Organization must also comply with USG iDURC policy and EPA DURC Order and will inform the appropriate government agency if funded by such agency of research with the agents or toxins identified in Section 6.2.1 of the iDURC Policy. If privately funded the recipient agrees to notify the National Institutes of Health at DURC@od.nih.gov.

**"Life Sciences Research,"* for purposes of the EPA DURC Order, and based on the definition of research in 40 CFR §26.102(d), is a systematic investigation designed to develop or contribute to generalizable knowledge involving living organisms (e.g., microbes, human beings, animals, and plants) and their products. EPA does not consider the following activities to be research: routine product testing, quality control, mapping, collection of general-purpose statistics, routine monitoring and evaluation of an operational program, observational studies, and the training of scientific and technical personnel. [Note: This is consistent with Office of Management and Budget Circular A-11.]

38. Research Misconduct

In accordance with 2 CFR 200.329, the recipient agrees to notify the EPA Project Officer in writing about research misconduct involving research activities that are supported in whole or in part with EPA funds under this project. EPA defines research misconduct as fabrication, falsification, or plagiarism in proposing, performing, or reviewing research, or in reporting research results [65 FR 76262. I], or ordering, advising or suggesting that subordinates engage in research misconduct. The recipient agrees to:

(1) Immediately notify the EPA Project Officer who will then inform the EPA Office of Inspector General (OIG) if, at any time, an allegation of research misconduct falls into one of the categories listed below:

- A. Public health or safety is at risk.
- B. Agency resources or interests are threatened.
- C. Circumstances where research activities should be suspended.
- D. There is a reasonable indication of possible violations of civil or criminal law.
- E. Federal action is required to protect the interests of those involved in the investigation.
- F. The research entity believes that the inquiry or investigation may be made public prematurely so that appropriate steps can be taken to safeguard evidence and protect the rights of those involved.
- G. Circumstances where the research community or public should be informed. [65 FR 76263.III]

(2) Report other allegations to the OIG when they have conducted an inquiry and determined that there is sufficient evidence to proceed with an investigation. [65 FR 76263. III]

39. Scientific Integrity Terms and Conditions

The recipient agrees to comply with [EPA's Scientific Integrity Policy](#) when conducting, supervising, and communicating science and when using or applying the results of science. For purposes of this award condition scientific activities include, but are not limited to, computer modelling, economic analysis, field sampling, laboratory experimentation, demonstrating new technology, statistical analysis, and writing a review article on a scientific issue. The recipient agrees to:

39.1 Scientific Products

- 39.1.1** Produce scientific products of the highest quality, rigor, and objectivity, by adhering to applicable EPA [information quality guidelines](#), [quality policy](#), and peer review policy.
- 39.1.2** Prohibit all recipient employees, contractors, and program participants, including scientists, managers, and other recipient leadership, from suppressing, altering, or otherwise impeding the timely release of scientific findings or conclusions.

- 39.1.3 Adhere to [EPA's Peer Review Handbook, 4th Edition](#), for the peer review of scientific and technical work products generated through EPA grants or cooperative agreements which, by definition, are not primarily for EPA's direct use or benefit.

39.2 Scientific Findings

- 39.2.1 Require that reviews regarding the content of a scientific product that are conducted by the project manager and other recipient managers and the broader management chain be based only on scientific quality considerations, e.g., the methods used are clear and appropriate, the presentation of results and conclusions is impartial.
- 39.2.2 Ensure scientific findings are generated and disseminated in a timely and transparent manner, including scientific research performed by employees, contractors, and program participants, who assist with developing or applying the results of scientific activities.
- 39.2.3 Include, when communicating scientific findings, an explication of underlying assumptions, accurate contextualization of uncertainties, and a description of the probabilities associated with both optimistic and pessimistic projections, if applicable.
- 39.2.4 Document the use of independent validation of scientific methods.
- 39.2.5 Document any independent review of the recipient's scientific facilities and testing activities, as occurs with accreditation by a nationally or internationally recognized sanctioning body.
- 39.2.6 Make scientific information available online in open formats in a timely manner, including access to data and non-proprietary models.

39.3 Scientific Misconduct

- 39.3.1 Prohibit intimidation or coercion of scientists to alter scientific data, findings, or professional opinions or non-scientific influence of scientific advisory boards. In addition, recipient employees, contractors, and program participants, including scientists, managers, and other leadership, shall not knowingly misrepresent, exaggerate, or downplay areas of scientific uncertainty.
- 39.3.2 Prohibit retaliation or other punitive actions toward recipient employees who uncover or report allegations of scientific and research misconduct, or who express a differing scientific opinion. Employees who have allegedly engaged in scientific or research misconduct shall be afforded the due process protections provided by law, regulation, and applicable collective bargaining agreements, prior to any action. Recipients shall ensure that all employees and contractors of the recipient shall be familiar with these protections and avoid the appearance of retaliatory actions.
- 39.3.3 Require all recipient employees, contractors, and program participants to act honestly and refrain from acts of research misconduct, including publication or reporting, as described in [EPA's Policy and Procedures for Addressing Research Misconduct](#), Section 9.C. Research misconduct does not include honest error or differences of opinion. While EPA retains the ultimate oversight authority for EPA-supported research, grant recipients conducting research bear primary responsibility for prevention and detection of research misconduct and for the inquiry, investigation, and adjudication of research misconduct alleged to have occurred in association with their own institution.
- 39.3.4 Take the actions required on the part of the recipient described in EPA's Policy and Procedures for Addressing Research Misconduct, Sections 6 through 9, when research misconduct is suspected or found.

39.4 Additional Resources

For more information about the Scientific Integrity Policy, an introductory video can be accessed at: <https://youtu.be/FQJCy8BXXq8>. A training video is available at: <https://youtu.be/Zc0T7fooot8>.

Public Policy Requirements

40. Civil Rights Obligations

This term and condition incorporates by reference the signed assurance provided by the recipient's authorized representative on: 1) EPA Form 4700-4, "Preaward Compliance Review Report for All Applicants and Recipients Requesting EPA Financial Assistance"; and 2) Certifications and Representations in Sam.gov or Standard Form 424D, as applicable.

These assurances and this term and condition obligate the recipient to comply fully with applicable civil rights statutes and implementing federal and EPA regulations.

a. Statutory Requirements

- i. In carrying out this agreement, the recipient must comply with:
 1. Title VI of the Civil Rights Act of 1964, which prohibits discrimination based on race, color, and national origin, including limited English proficiency (LEP), by entities receiving Federal financial assistance.
 2. Section 504 of the Rehabilitation Act of 1973, which prohibits discrimination against persons with disabilities by entities receiving Federal financial assistance; and
 3. The Age Discrimination Act of 1975, which prohibits age discrimination by entities receiving Federal financial assistance.
- ii. If the recipient is an education program or activity (e.g., school, college or university) or if the recipient is conducting an education program or activity under this agreement, it must also comply with:
 1. Title IX of the Education Amendments of 1972, which prohibits discrimination on the basis of sex in education programs and activities operated by entities receiving Federal financial assistance. For further information about your compliance obligations regarding Title IX, see 40 CFR Part 5 and <https://www.justice.gov/crt/title-ix>
- iii. If this agreement is funded with financial assistance under the Clean Water Act (CWA), the recipient must also comply with:
 1. Section 13 of the Federal Water Pollution Control Act Amendments of 1972, which prohibits discrimination on the basis of sex in CWA-funded programs or activities.

b. Regulatory Requirements

- i. The recipient agrees to comply with all applicable EPA civil rights regulations, including:
 1. For Title IX obligations, 40 C.F.R. Part 5; and
 2. For Title VI, Section 504, Age Discrimination Act, and Section 13 obligations, 40 CFR Part 7.
 3. For statutory and national policy requirements, including those prohibiting discrimination and those described in Executive Order 13798 promoting free speech and religious freedom, 2 CFR 200.300.
 4. As noted on the EPA Form 4700-4 signed by the recipient's authorized representative, these regulations establish specific requirements including maintaining compliance information, establishing grievance procedures, designating a Civil Rights Coordinator and providing notices of non-discrimination.

c. TITLE VI – LEP, Public Participation and Affirmative Compliance Obligation

- i. As a recipient of EPA financial assistance, you are required by Title VI of the Civil Rights Act to provide meaningful access to LEP individuals. In implementing that requirement, the recipient agrees to use as a guide the Office of Civil Rights (OCR) document entitled "Guidance to Environmental Protection Agency Financial Assistance Recipients Regarding Title VI Prohibition Against National Origin Discrimination Affecting Limited English Proficient Persons." The guidance can be found at:

<https://www.federalregister.gov/documents/2004/06/25/04-14464/guidance-to-environmental-protection-agency-financial-assistance-recipients-regarding-title-vi>

- ii. If the recipient is administering permitting programs under this agreement, the recipient agrees to use as a guide OCR's Title VI Public Involvement Guidance for EPA Assistance Recipients Administering Environmental Permitting Programs. The Guidance can be found at: <https://www.govinfo.gov/content/pkg/FR-2006-03-21/pdf/06-2691.pdf>
- iii. In accepting this assistance agreement, the recipient acknowledges it has an affirmative obligation to implement effective Title VI compliance programs and ensure that its actions do not involve discriminatory treatment and do not have discriminatory effects even when facially neutral. The recipient must be prepared to demonstrate to EPA that such compliance programs exist and are being implemented or to otherwise demonstrate how it is meeting its Title VI obligations.

41. Drug-Free Workplace

The recipient organization of this EPA assistance agreement must make an ongoing, good faith effort to maintain a drug-free workplace pursuant to the specific requirements set forth in Title 2 CFR Part 1536 Subpart B. Additionally, in accordance with these regulations, the recipient organization must identify all known workplaces under its federal awards, and keep this information on file during the performance of the award.

Those recipients who are individuals must comply with the drug-free provisions set forth in Title 2 CFR Part 1536 Subpart C.

The consequences for violating this condition are detailed under Title 2 CFR Part 1536 Subpart E. Recipients can access the Code of Federal Regulations (CFR) Title 2 Part 1536 at www.ecfr.gov/.

42. Hotel-Motel Fire Safety

Pursuant to 15 USC 2225a, the recipient agrees to ensure that all space for conferences, meetings, conventions or training seminars funded in whole or in part with federal funds complies with the protection and control guidelines of the Hotel and Motel Fire Safety Act (PL 101-391, as amended). Recipients may search the Hotel-Motel National Master List at <https://apps.usfa.fema.gov/hotel/> to see if a property is in compliance, or to find other information about the Act.

43. Lobbying Restrictions

a) This assistance agreement is subject to lobbying restrictions as described below. Applicable to all assistance agreements:

- i) The chief executive officer of this recipient agency shall ensure that no grant funds awarded under this assistance agreement are used to engage in lobbying of the Federal Government or in litigation against the U.S. unless authorized under existing law. The recipient shall abide by the Cost Principles available at 2 CFR Part 200 which generally prohibits the use of federal grant funds for litigation against the U.S. or for lobbying or other political activities.
- ii) The recipient agrees to comply with Title 40 CFR Part 34, New Restrictions on Lobbying. The recipient shall include the language of this provision in award documents for all subawards exceeding \$100,000 and require that subrecipients submit certification and disclosure forms accordingly.
- iii) In accordance with the Byrd Anti-Lobbying Amendment, any recipient who makes a prohibited expenditure under Title 40 CFR Part 34 or fails to file the required certification or lobbying forms

shall be subject to a civil penalty of not less than \$10,000 and not more than \$100,000 for each such expenditure.

- iv) Contracts awarded by a recipient shall contain, when applicable, the anti-lobbying provision as stipulated in the Appendix II to Part 200—Contract Provisions for Non-Federal Entity Contracts Under Federal Awards.
- v) By accepting this award, the recipient affirms that it is not a nonprofit organization described in Section 501(c)(4) of the Internal Revenue Code of 1986 as required by Section 18 of the Lobbying Disclosure Act; or that it is a nonprofit organization described in Section 501(c)(4) of the Code but does not and will not engage in lobbying activities as defined in Section 3 of the Lobbying Disclosure Act. Nonprofit organizations exempt from taxation under section 501(c)(4) of the Internal Revenue Code that engage in lobbying activities are ineligible for EPA subawards.

b) Applicable to assistance agreements when the amount of the award is over \$100,000:

- i) By accepting this award, the recipient certifies, to the best of its knowledge and belief, that:
 - (1) No Federal appropriated funds have been or will be paid, by or on behalf of the recipient, to any person for influencing or attempting to influence an officer or employee of any agency, a Member of Congress, an officer or employee of Congress, or an employee of a Member of Congress in connection with the awarding of any Federal contract, the making of any Federal grant, the making of any Federal loan, the entering into of any cooperative agreement, and the extension, continuation, renewal, amendment, or modification of any Federal contract, grant, loan, or cooperative agreement.
 - (2) If any funds other than Federal appropriated funds have been paid or will be paid to any person for influencing or attempting to influence an officer or employee of any agency, a Member of Congress, or any employee of a Member of Congress in connection with this Federal grant or cooperative agreement, the recipient shall complete and submit the linked [Standard Form -- LLL, "Disclosure Form to Report Lobbying."](#) in accordance with its instructions.
 - (3) The recipient shall require that the language of this certification be included in the award documents for all subawards exceeding \$100,000 at all tiers (including subcontracts, subgrants, and contracts under grants, loans, and cooperative agreements) and that all subrecipients shall certify and disclose accordingly.
- ii) This certification is a material representation of fact upon which reliance was placed when this transaction was made or entered into. Submission of this certification is a prerequisite for making or entering into this transaction imposed by Section 1352, Title 31, U.S. Code. Any person who fails to file the required certification shall be subject to a civil penalty of not less than \$10,000 and not more than \$100,000 for each failure.

44. Recycled Paper

When directed to provide paper documents, the recipient agrees to use recycled paper and double-sided printing for all reports which are prepared as a part of this agreement and delivered to EPA. This requirement does not apply to reports prepared on forms supplied by EPA.

45. Resource Conservation and Recovery Act

Consistent with goals of section 6002 of RCRA (42 U.S.C. 6962), State and local institutions of higher education, hospitals and non-profit organization recipients agree to give preference in procurement programs to the purchase of specific products containing recycled materials, as identified in 40 CFR Part 247.

Consistent with section 6002 of RCRA (42 U.S.C. 6962) and 2 CFR 200.323, State agencies or agencies of a political subdivision of a State and its contractors are required to purchase certain items made from recycled materials, as identified in 40 CFR Part 247, when the purchase price exceeds \$10,000 during the course of a fiscal year or where the quantity of such items acquired in the course of the preceding fiscal year was \$10,000 or more. Pursuant to 40 CFR 247.2 (d), the recipient may decide not to procure such items if they are not reasonably available in a reasonable period of time; fail to meet reasonable performance standards; or are only available at an unreasonable price.

46. Trafficking in Persons

a. Provisions applicable to a recipient that is a private entity.

- i. The recipient, the recipient's employees, subrecipients under this award, and subrecipients' employees may not—
 1. Engage in severe forms of trafficking in persons during the period of time that the award is in effect;
 2. Procure a commercial sex act during the period of time that the award is in effect; or
 3. Use forced labor in the performance of the award or subawards under the award.
- ii. We as the Federal awarding agency may unilaterally terminate this award, without penalty, if the recipient or a subrecipient that is a private entity—
 1. Is determined to have violated a prohibition in paragraph a of this award term; or
 2. Has an employee who is determined by the agency official authorized to terminate the award to have violated a prohibition in paragraph a of this award term through conduct that is either—
 - a. Associated with performance under this award; or
 - b. Imputed to the recipient or subrecipient using the standards and due process for imputing the conduct of an individual to an organization that are provided in 2 CFR Part 180, "OMB Guidelines to Agencies on Governmentwide Debarment and Suspension (Nonprocurement)," as implemented by our Agency at 2 CFR Part 1532.

b. Provision applicable to a recipient other than a private entity. EPA may unilaterally terminate this award, without penalty, if a subrecipient that is a private entity—

- i. Is determined to have violated an applicable prohibition in paragraph a. of this award term; or
- ii. Has an employee who is determined by the agency official authorized to terminate the award to have violated an applicable prohibition in paragraph a of this award term through conduct that is either—
 1. Associated with performance under this award; or
 2. Imputed to the subrecipient using the standards and due process for imputing the conduct of an individual to an organization that are provided in 2 CFR Part 180, "OMB Guidelines to Agencies on Governmentwide Debarment and Suspension (Nonprocurement)," as implemented by EPA at 2 CFR Part 1532.

c. Provisions applicable to any recipient.

- i. The recipient must inform the EPA immediately of any information received from any source alleging a violation of a prohibition in paragraph a of this award term.
- ii. Our right to terminate unilaterally that is described in paragraph a and b:

1. Implements section 106(g) of the Trafficking Victims Protection Act of 2000 (TVPA), as amended (22 U.S.C. 7104(g)), and
 2. Is in addition to all other remedies for noncompliance that are available to us under this award.
- iii. The recipient must include the requirements of paragraph a of this award term in any subaward made to a private entity.

d. Definitions. For purposes of this award term:

- i. “Employee” means either:
 1. An individual employed by you or a subrecipient who is engaged in the performance of the project or program under this award; or
 2. Another person engaged in the performance of the project or program under this award and not compensated by you including, but not limited to, a volunteer or individual whose services are contributed by a third party as an in-kind contribution toward cost sharing or matching requirements.
- ii. “Forced labor” means labor obtained by any of the following methods: the recruitment, harboring, transportation, provision, or obtaining of a person for labor or services, through the use of force, fraud, or coercion for the purpose of subjection to involuntary servitude, peonage, debt bondage, or slavery.
- iii. “Private entity”:
 1. Means any entity other than a State, local government, Indian tribe, or foreign public entity, as those terms are defined in 2 CFR 175.25.
 2. Includes:
 - a. A nonprofit organization, including any nonprofit institution of higher education, hospital, or tribal organization other than one included in the definition of Indian tribe at 2 CFR 175.25(b).
 - b. A for-profit organization.
- iv. “Severe forms of trafficking in persons,” “commercial sex act,” and “coercion” have the meanings given at section 103 of the TVPA, as amended (22 U.S.C. 7102).

Appendix L

RI Office of Diversity, Equity, and Opportunity MBE Forms



**State of Rhode Island
 Division of Equity, Diversity, and Inclusion (DEDI)
 Minority Business Enterprise Compliance Office
 Minority Business Enterprise Utilization Plan**

Company Name: _____

Representative's Name who administers MBE Program: _____

Street Address: _____

City, State, Zip: _____ Telephone: _____

Email: _____ Project Location: _____

Bid or Project #: _____ Date Bid Opened: _____

Description of Work: _____

Contract Value: _____ MBE % Assigned: _____

Total # of All Subcontractors/Suppliers used: _____ # of MBE Subcontractors/Suppliers used: _____

List All Subcontractors/Suppliers/Consultants/Independent Contractors – Total Dollar Amounts – Scope of Work:

Subcontractor / Supplier	Dollar Award	Scope/Description of Work	RI Certified M/WBE Yes/No

Please note that all MBE/WBE firms must be certified by the RI MBE Compliance Office, and that MBE/WBE firms must self-perform 100% of the work with their own forces or subcontract to another RI certified MBE/WBE in order to receive participation credit. Vendors may count 60% of expenditures for materials and supplies obtained from an MBE certified as a regular dealer/supplier, and 100% of such expenditures obtained from an MBE/WBE certified as a manufacturer. For firms certified as a broker, you may receive MBE participation credit only for the fees and commissions charged for the procurement of the good and materials, but not the cost of the materials themselves.

The above referenced contract will not be released until this plan has been approved by the Director of the Department of Administration or its designee.

For assistance and advice in identifying MBE/WBE firms, please call the Minority Business Enterprise Compliance Office at (401) 574-8253. The directory of all certified MBE firms is also located at www.mbe.ri.gov.

Signature of Authorized Agent of Business: _____ Date: _____

Send Completed Form to:
Kate Constance Brody, Esq. Administrator – MBE Compliance Office
Division of Equity, Diversity, and Inclusion (DEDI)
Minority Business Enterprise Compliance Office
One Capitol Hill, 3rd Floor
Providence, RI 02908
Phone: (401) 574-8670
Kate.Brody@doa.ri.gov

Office of Diversity, Equity and Opportunity (ODEO)
MBE Compliance Office
1 Capitol Hill, 3rd Floor
Providence, RI 02908

(401) 574-8670
www.mbe.ri.gov

Pursuant to RIGL 37-14.1 as well as the regulations promulgated thereto, the MBE Compliance Office requires that you complete the following table. Please note that these figures will be verified with the MBEs identified. If there are outstanding issues, such as retainage or a dispute, please indicate and attach supporting documentation for same. Also note that copies of invoice and cancelled checks for payment to all MBE subcontractors and suppliers are required.

Contractor/Vendor Name:

Project Name & Location:

Original Prime Contract Amount: \$ _____ Current Prime Contract Amount: \$ _____ % Complete: _____

MBE/WBE Subcontractor	Original Contract Amount	Change Orders	Revised Contract Value	% Completed To Date	Amount Paid To Date	Amount Due	Retainage %	Retainage Amount	Explanation

I declare, under penalty of perjury, that the information provided in this verification form and supporting documents is true and correct.

Signature

Date

Printed Name

Notary Certificate:

Sworn before me this _____ day of _____, 20____.

Notary Signature

Commission Expires

Appendix M

National Grid Cast Iron Gas Main Encroachment Prevention

GAS UTILITY GENERAL NOTES

1. CONTRACTOR SHALL FOLLOW THE GUIDELINES LISTED IN NATIONAL GRID'S "GUIDELINES FOR WORKING AROUND GAS UTILITIES", DOCUMENT ATTACHED.
2. DEPTH OF GAS FACILITIES ARE UNKNOWN AND COULD BE SHALLOW, USE CAUTION WHEN WORKING IN THE VICINITY OF ANY GAS FACILITY, HAND DIGGING ONLY.
3. NATIONAL GRID REQUIRES A MINIMUM OF ONE FOOT OF SEPARATION BETWEEN CROSSING UTILITIES AND EXISTING GAS FACILITIES.
4. NATIONAL GRID REQUIRES A MINIMUM OF THREE FEET OF SEPARATION BETWEEN THE GAS MAIN AND THE PARALLEL FACILITY FOR STEEL AND PLASTIC GAS MAINS. **FOR CAST IRON GAS MAIN SEE LINE ITEM FOR ENCROACHMENT GUIDELINES.**
5. IF A **GAS MAIN IS** EXPOSED OR **GOING TO BE EXPOSED** CALL NATIONAL DISPATCH OFFICE AT 877-304-1203 FOR AN INSPECTOR TO BE DISPATCHED TO THE SITE TO INSPECT THE LINE BEFORE BACKFILL.
6. IF A **GAS MAIN OR GAS MAIN COATING IS** DAMAGED CALL NATIONAL DISPATCH OFFICE AT 877-304-1203 FOR AN INSPECTOR TO BE DISPATCHED TO THE SITE FOR REPAIR BEFORE BACKFILL.
7. FOR ANY EXPOSED GAS FACILITY, PROVIDE BACKFILL MATERIALS AND COMPACT THE BACKFILL MATERIALS IN ACCORDANCE WITH NATIONAL GRID'S "GUIDELINES FOR BACKFILL AND COMPACTION AROUND GAS PIPES", DOCUMENT ATTACHED.
8. WHEN CROSSING OR EXPOSING A STEEL OR PLASTIC GAS FACILITY SUPPORT MAY BE REQUIRED. FOLLOW THE GUIDELINES LISTED AND ILLUSTRATED IN NATIONAL GRID'S "SUPPORT REQUIREMENTS FOR EXPOSED & UNDERMINED STEEL OR PLASTIC GAS FACILITIES", DOCUMENT (DWG NO. CNST-6045) ATTACHED.
9. ALL GAS VALVE BOXES SHALL BE ADJUSTED TO THE NEW ROAD/SIDEWALK SURFACE. VALVE BOXES, IF REQUIRED FOR REPLACEMENT, CAN BE OBTAINED AT NATIONAL GRID'S PROVIDENCE LOCATION, 477 DEXTER STREET, PROVIDENCE, RI OR LINCOLN LOCATION, 642 GEORGE WASHINGTON HIGHWAY (QUANTITIES 5 OR LESS). GAS VALVE BOXES NEED TO BE ACCESSIBLE AT ALL TIMES TO BE OPERATED BY NATIONAL GRID IN THE EVENT OF AN EMERGENCY.
10. ALL CATHODIC PROTECTION BOXES (BOXES THAT CONTAIN WIRES THAT GO DOWN TO THE GAS MAIN) SHALL BE ADJUSTED TO THE NEW ROAD/SIDEWALK SURFACE. CARE SHALL BE EXERCISED WHEN ADJUSTING SO AS NOT TO DAMAGE THE WIRES. IF THE WIRES ARE DAMAGED OR IF ASSISTANCE IS NEEDED, CONTACT NATIONAL GRID CORROSION ENGINEER TO VISIT THE SITE. CONTACT RICK LEPAGE 508-948-8432 OR MIKE HARMON 781-953-2545. NEW BOXES, IF REQUIRED, CAN BE OBTAINED AT NATIONAL GRID'S PROVIDENCE FACILITY, 477 DEXTER ST, PROVIDENCE, RI OR NATIOANL GRID'S LINCOLN FACILITY, 642 GEORGE WASHINGTON HIGHWAY, LINCOLN, RI (QUANTITIES 5 OR LESS). CONTRACTOR SHALL FOLLOW THE GUIDELINES LISTED IN NATIONAL GRID'S "GUIDELINES FOR WORKING AROUND CORROSION CONTROL SYSTEM COMPONENTS", DOCUMENT ATTACHED.

11. IF EXCAVATING PARALLEL TO OR CROSSING A CAST IRON GAS FACILITY THEN ENCROACHMENT OF THE CAST IRON LINE IS A POSSIBILITY AND A CONCERN WHERE REPLACEMENT MAY BE REQUIRED. WHENEVER AN EXCAVATION IS IN THE VICINITY OF A CAST IRON GAS MAIN CONTACT NATIONAL GRID ENCROACHMENT ENGINEER TO BE ON SITE, CALL NICOLE TIMOTEO AT 781-514-0768. GUIDELINES IN AVOIDING AN ENCROACHMENT ARE LISTED IN NATIONAL GRID'S "CAST IRON GAS MAIN ENCROACHMENT PREVENTION", DOCUMENT ATTACHED.
12. IF EXCAVATING PARALLEL TO OR CROSSING A CAST IRON FACILITY THAT IS GREATER THAN 8", THIS LINE IS NOT COVERED UNDER THE ENCROACHMENT GUIDELINES AND LAW. NATIONAL GRID DOES NOT ALLOW MORE THAN 10' OF GAS MAIN TO BE EXPOSED AND ONLY ALLOWS (1) BELL & SPIGOT JOINT TO BE EXPOSED. IF A BELL & SPIGOT JOINT IS EXPOSED SAID JOINT MUST BE LEAK CLAMPED BEFORE BACKFILL UNLESS A CLAMP IS ALREADY IN PLACE. PROVIDE BACKFILL MATERIALS AND COMPACT THE BACKFILL MATERIALS IN ACCORDANCE WITH NATIONAL GRID'S "GUIDELINES FOR BACKFILL AND COMPACTION AROUND GAS PIPES", DOCUMENT ATTACHED. MINIMUM 95% COMPACTION OF THE SOIL BELOW A CAST IRON IS ALWAYS REQUIRED. ALWAYS CALL NATIONAL GRID DAMAGE PREVENTION DEPARTMENT FOR AN INSPECTOR TO BE DISPATCHED TO SITE. CALL ED SOUZA AT 401-283-9159.
13. DUE TO SYSTEM RELIABILITY AND PUBLIC SAFETY CONCERNS, IT IS NATIONAL GRID'S PRACTICE TO RESTRICT ALL CONSTRUCTION WORK ON OR NEAR GAS FACILITIES BETWEEN NOVEMBER 15TH AND APRIL 15TH. ALL SCHEDULED WORK SHOULD BE COMPLETED BETWEEN APRIL 15TH AND NOVEMBER 15TH. AS GAS USAGE PEAK DURING THE MONTHS OF DECEMBER TO MARCH DRIVEN BY HEATING NEEDS, NATIONAL GRID'S PRIORITY IS TO PROVIDE OUR CUSTOMERS WITH SAFE AND RELIABLE GAS SERVICE. ANY WORK ON OR NEAR THE GAS FACILITY WILL EXPOSE OUR CUSTOMERS TO UNNECESSARY RISK. EXCEPTIONS WILL BE CONSIDERED ON A CASE BY CASE BASIS. APPROVALS FROM GAS CONTROL, OPERATIONAL ENGINEERING, AND PROJECT ENGINEERING WILL BE REQUIRED FOR THESE CASES.
14. FOR A GAS LEAK CALL 800-640-1595.
15. FOR A DAMAGED GAS FACILITY CALL 800-870-1664.

Cast Iron Gas Main Encroachment Prevention

nationalgrid

Nicole Timoteo
Encroachment Engineer
Gas Operations & Construction
Rhode Island
Cell: 781-514-0768
nicole.timoteo@nationalgrid.com

477 Dexter Street
Providence, RI 02863

CI Encroachments

- CI Encroachments can occur when excavating under or next to CI gas mains
- CI Encroachments can occur Even when a gas main is not exposed
- Two types of Encroachments: Undermine and Parallel
 - Undermine Encroachments (Cross Trench)
 - Parallel Encroachments

Cross Trench with Tunneling

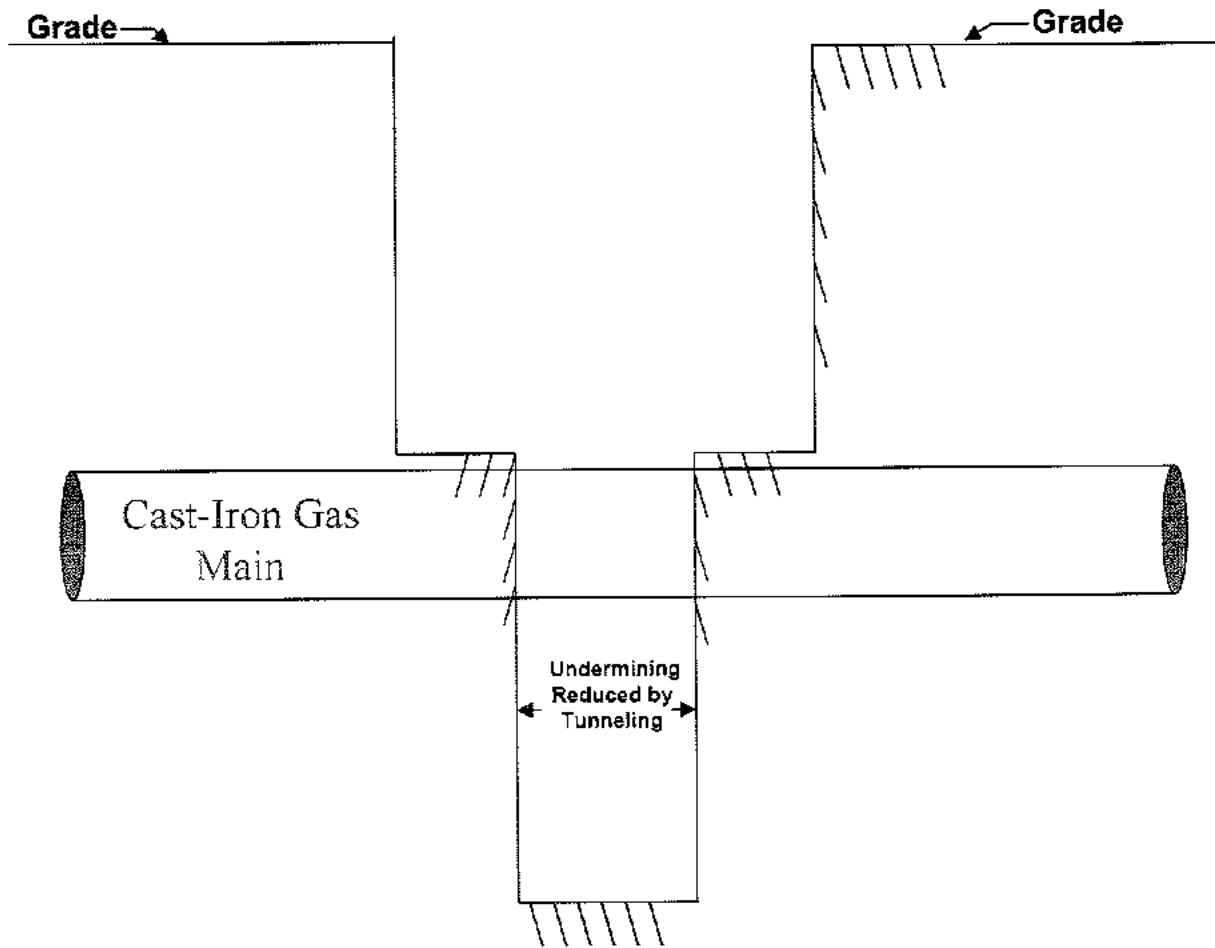

Elevation View

Tunneling is an Effective Way of Preventing Encroachments

Cross Trench

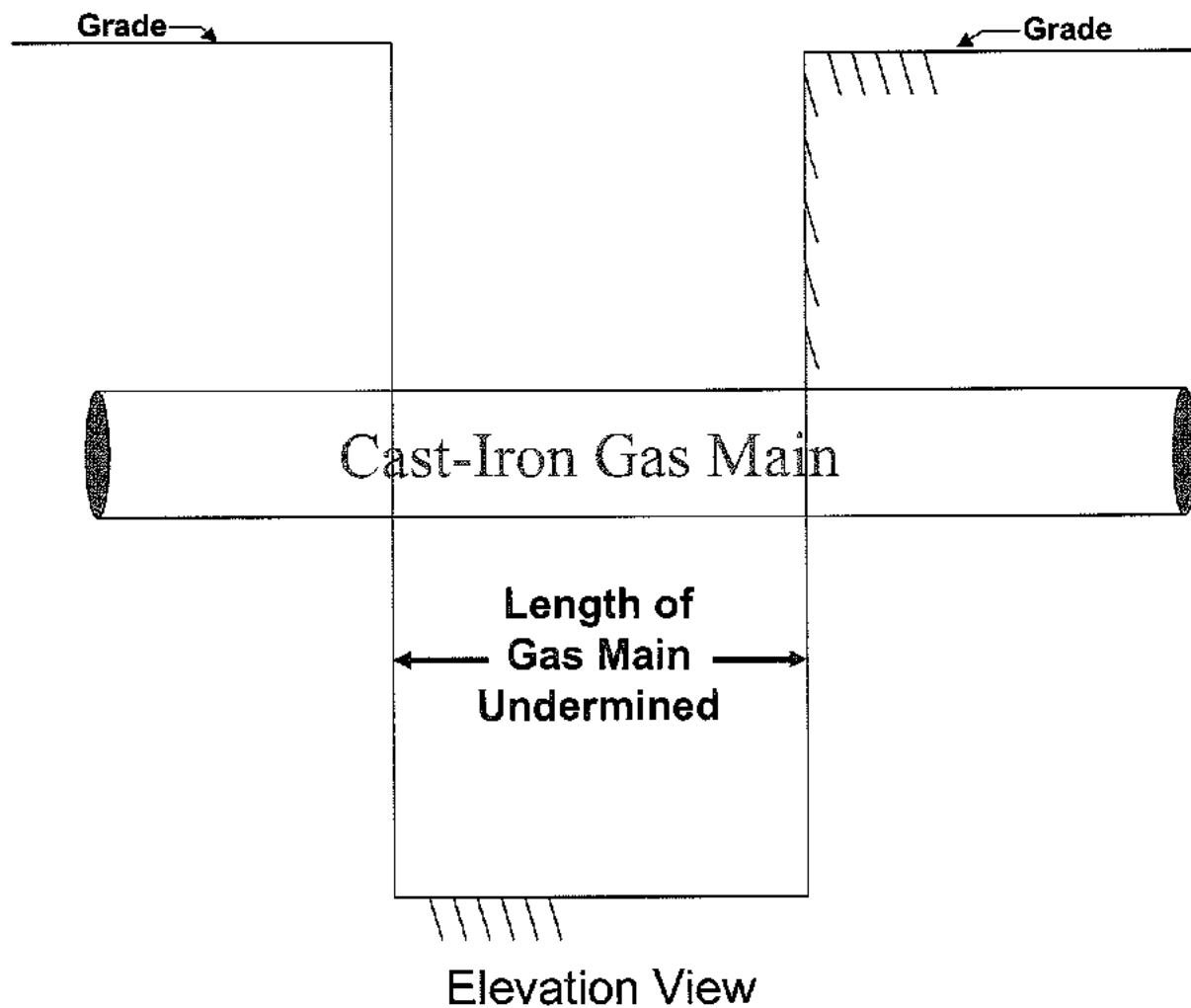

Cross Trench - Rules of Thumb:

- The shorter the undermine, the better
- Limiting the length of the undermine to 30" or less will always avoid an encroachment

Cast Iron Encroachments can occur even when the Gas Main is not Exposed

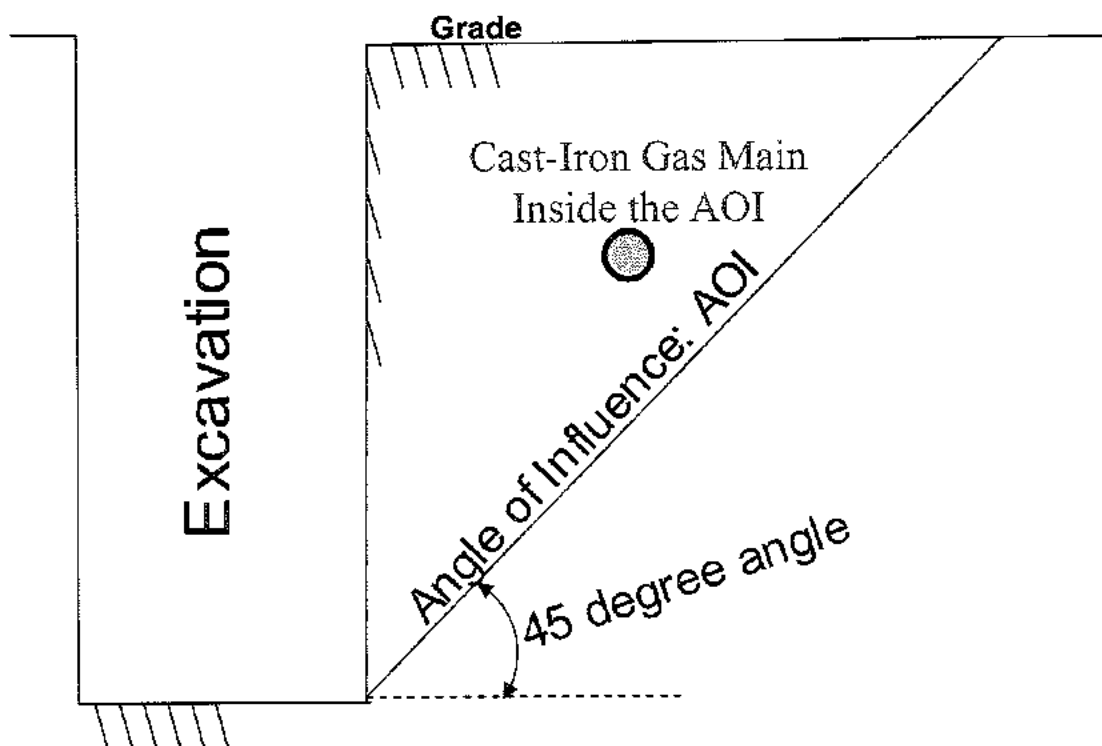

Angle of Influence:

- The AOI extends up from the bottom of the excavation at a 45 degree angle
- The AOI can affect cast iron gas mains even if the gas main is not exposed

Excavation Next to Gas Main

(view from above looking down)

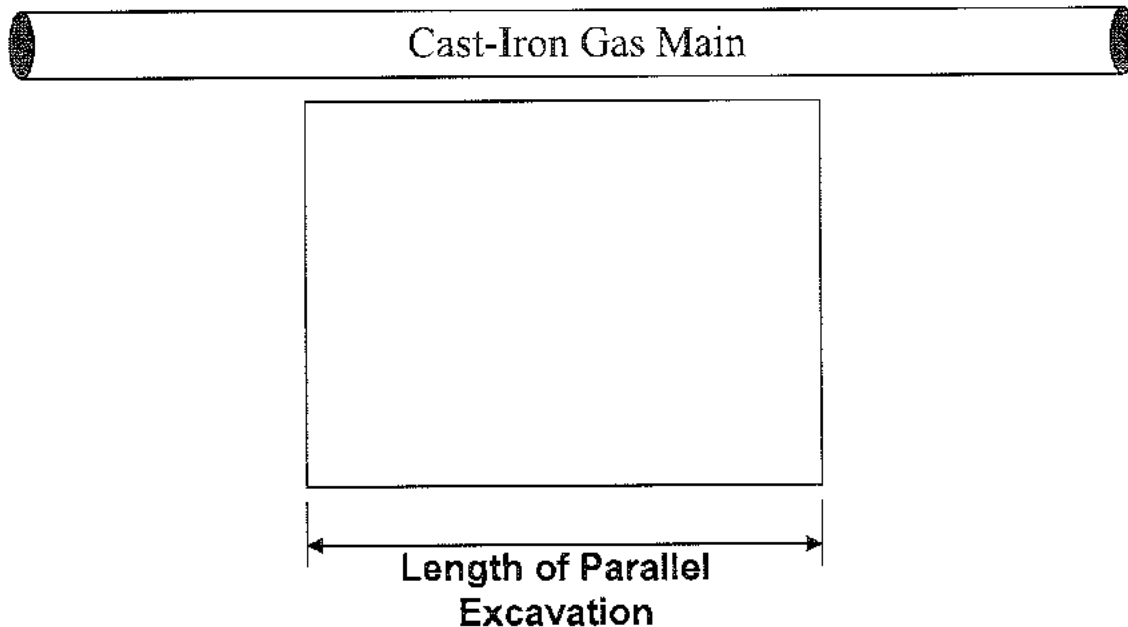

Plan View

Parallel Excavation Rule of Thumb:

- Limiting the length of the parallel to 7'-6" or less will always avoid an encroachment

Parallel Excavation with Sloped Ends

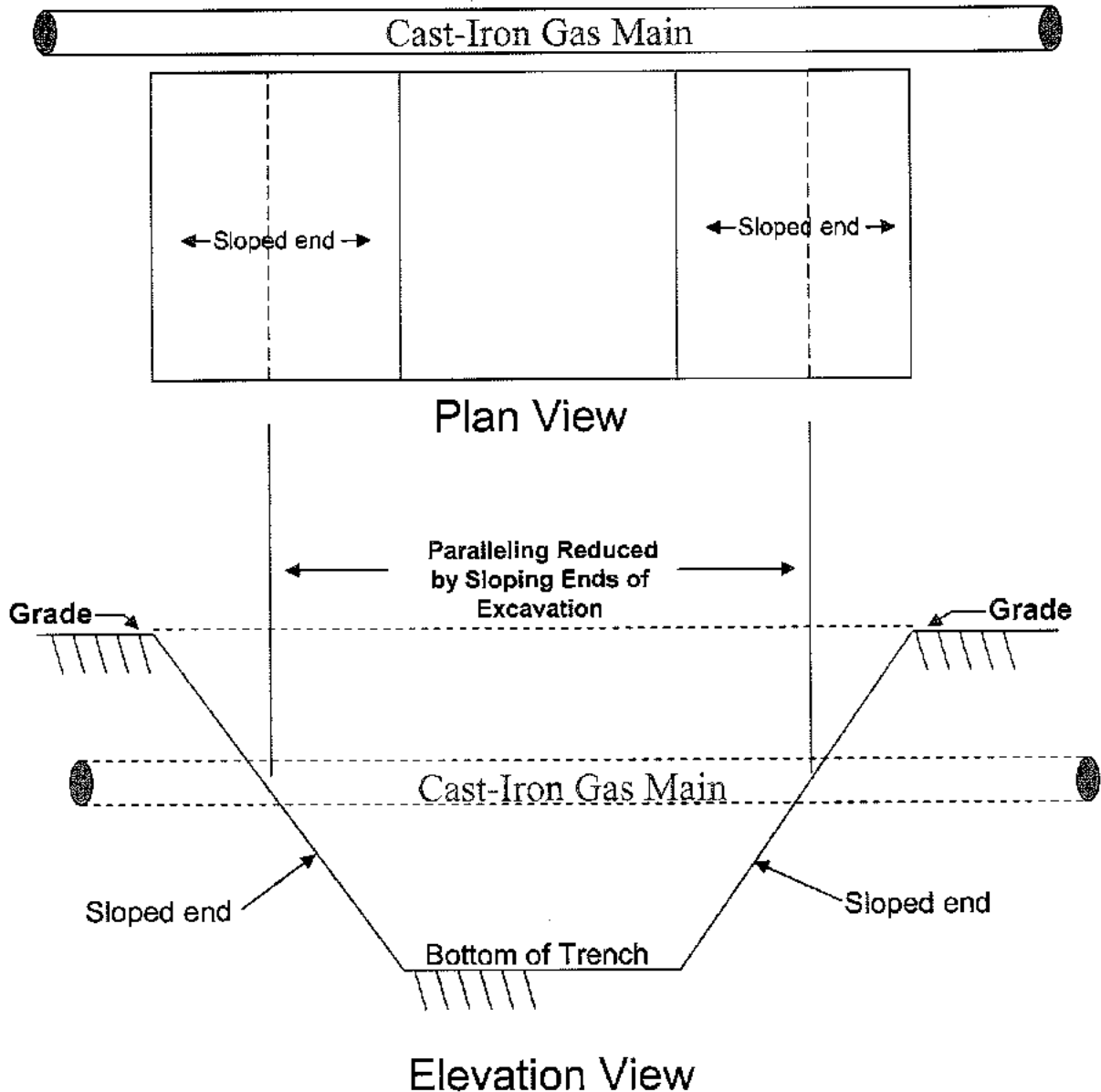

Sloping the ends of an Excavation can be an Effective Way of Preventing Encroachments

Trenching Next to Gas Main

(view from above looking down)

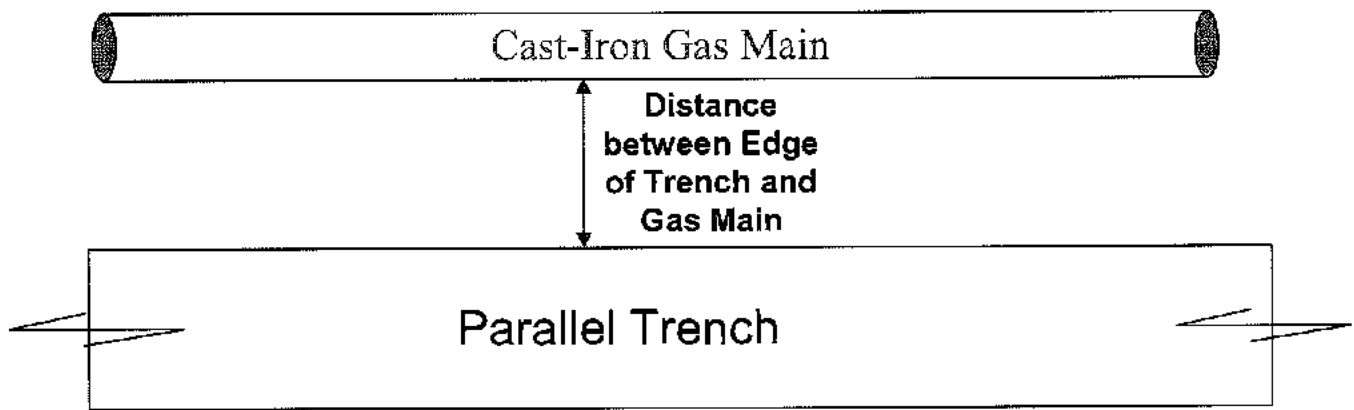

Plan View

Parallel Trenching Rules of Thumb:

- The greater the separation between the gas main and the trench, the better
- Keeping the distance between the excavation and the gas main greater than the (depth of the trench - 2') will in most cases avoid an encroachment

CI Encroachments

- CI Encroachments can occur when excavating under or next to CI gas mains
- CI Encroachments can occur **Even when a gas main is not exposed**
- Two types of Encroachments: Undermine and Parallel
 - **Undermine Encroachments (Cross Trench)**
 - In all cases, the shorter the length of gas main undermined the better
 - Limiting undermining to less than 30" in length will always avoid an encroachment
 - Tunneling under the gas main can be an effective method for avoiding encroachments
 - **Parallel Encroachments**
 - Parallel Encroachments can occur even if the gas main is not exposed
 - In all cases, the greater the separation between the gas main and the parallel excavation, the better
 - Limiting excavations adjacent to gas main to less than 7'-6" in length will always avoid an encroachment
 - Keeping parallel excavations more than the (depth of the trench – 2') from gas main in most cases will prevent an encroachment



10/01/12

Guidelines for Working Around Gas Utilities

Notification of Construction

National Grid requests at least six week advanced notification prior to the start of construction to perform scheduled work in the proposed project area. Be aware that some gas work cannot be performed during the normal heating season.

Support and Protect

Contractor must call Dig Safe to have the gas mains and services marked out before construction. Care must be exercised when saw cutting over any gas infrastructure, especially services, which are more shallow than the main. Depth of gas mains vary. Contractor shall dig test pits in order to ascertain exact locations, cover and invert elevations, clearances, alignment and operating status of existing gas facilities. Contractor shall exercise extreme caution when excavating in the vicinity of any gas facility. Hand excavation shall be performed to locate all gas facilities and whenever digging within 24" of gas facilities. If cover over gas piping is removed the required cover must be replaced, or if not feasible, National Grid must be notified for review of the issue. Undermined gas pipe must be adequately supported and protected from damage. Contact National Grid engineer for guidelines regarding proper pipe support. Significant vibration from pile driving and such may negatively impact gas facilities, particularly cast iron mains and regulator station vaults. Contact National Grid engineer prior to performing such activities as well as operations which may undermine gas facilities such as micro-tunneling, jacking, directional drilling, etc.

Gas Leaks

For any gas leak please call the appropriate number immediately.

Greater Boston - 800-233-5325

Other Massachusetts – 800-548-8000

Rhode Island – 800-640-1595

Types of Gas Facilities

Gas mains and services are made of several different materials and contain a wide range of pressures. Typical materials used for buried gas pipe includes bare steel, coated steel, plastic, cast iron, wrought iron, ductile iron, and copper. Never assume that a pipe is not gas. At times gas lines are inserted into older lines to save excavation cost.

Exposure of Gas Facilities

If any gas mains or services become exposed, National Grid must be notified to inspect the line before backfilling. Also any damage that may have been made to the pipe or pipe coating will need to be repaired by National Grid before backfilling. Contact our Dispatch office at (877) 304-1203 for inspection. It is important that even minor damage or scrapes be reported to National Grid. Backfill shall be 6" of sand around the gas line and clean compacted fill above.



Regulator Stations

Gas regulator stations are particularly critical facilities and National Grid must be notified whenever work is to take place within 200 feet of a station. Regulator stations are typically in buried vaults accessed through either manhole covers or aluminum doors. **ONLY AUTHORIZED NATIONAL GRID EMPLOYEES SHALL OPEN A REGULATOR STATION VAULT.** Be aware that a complex nest of piping and valves often exists in the vicinity outside the vaults.

Blasting

National Grid must be notified of any blasting that will take place within 200 feet of a gas utility. National Grid must be supplied with a detailed blast plan for blasting in the vicinity of gas facilities. The evaluation of the blast plan by a National Grid engineer may take some time, therefore, blast plan data should be submitted at least two weeks prior to the planned blasting. As a general rule blasting will not be permitted within 10 feet of a gas line and PPV at the nearest gas pipe shall not exceed 5 in/sec. PPV at the nearest gas main shall be monitored.

Valves

Access to gas valves must be maintained throughout construction and left at grade at the end of construction. Should valve boxes be damaged and need to be replaced National Grid will supply replacements upon request. **NEVER OPERATE A GAS VALVE. ONLY NATIONAL GRID SHALL OPERATE GAS VALVES.**

Clearance

Adequate clearance must be provided when installing other utilities, foundations, structures, etc. Contact National Grid engineer for guidance.

GUIDELINES FOR SUPPORT of GAS PIPES TEMPORARY SUPPORT of GAS PIPES

DESCRIPTION

This work shall consist of temporarily supporting gas pipes, during construction work and related activities. Any gas pipe that is exposed shall follow this specification stipulating pipe support criteria. Whether gas pipe is located directly in the excavation trench box or if it is located in the excavated adjacent slopes (Angle of Repose) all gas pipe must be supported.

When gas pipe is undermined for 5 feet or more at any given time, Nationalgrid must be notified and a decision will be made on what type of support system will be utilized. Nationalgrid reserves the right to insist that a Rhode Island Registered Professional Engineer submit plans, if the gas pipe being supported exceeds an unsupported span length of 12 feet, is located in cohesive soils (wet, silty soils), or feels that the structural integrity of the gas distribution system may be compromised.

All cast iron gas pipes will be replaced and not be temporarily supported, unless determined differently by Nationalgrid. This criterion is in accordance with Section 6315.6 of Nationalgrid's *Operations Standards and Practices Manual*.

The following criteria should be used as guidelines when undermining existing steel or plastic gas pipes:

STEEL GAS PIPE

If pipe is undermined for a distance between 5 and 10 feet, the support system should consist, as a minimum, of adequately sized steel I-beams, steel plate girders, or 6" x 6" wood beams (Hem-Fir) with a sling supporting the pipe mid-span. For distances greater than 10 feet, these temporary support beams will have slings supporting the pipe every 10 to 12 feet along the length of the undermined pipe. Furthermore, when a mechanical coupling or fitting is encountered at any span length, the slings must be placed on either side of the fitting to avoid buckling.

PLASTIC GAS PIPE

If pipe is undermined for a distance between 5 and 10 feet, the support system should consist, as a minimum, of adequately sized steel I-beams, steel plate girders, or 4" x 4" wood beams (Hem-Fir) with a sling supporting the pipe mid-span. For distances greater 10 feet, these temporary support beams will have slings supporting pipe every 10 to 12 feet along the length of the undermined pipe. Furthermore, when a mechanical coupling or fitting is encountered, the slings must be placed on either side of the fitting to avoid buckling.

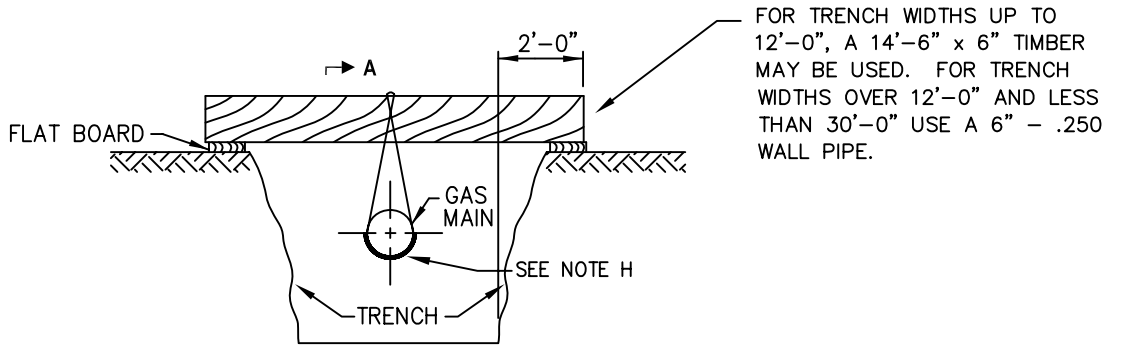

FOR TRENCH WIDTHS UP TO 12'-0", A 14'-6" x 6" TIMBER MAY BE USED. FOR TRENCH WIDTHS OVER 12'-0" AND LESS THAN 30'-0" USE A 6" - .250 WALL PIPE.

EXPOSED SUPPORT

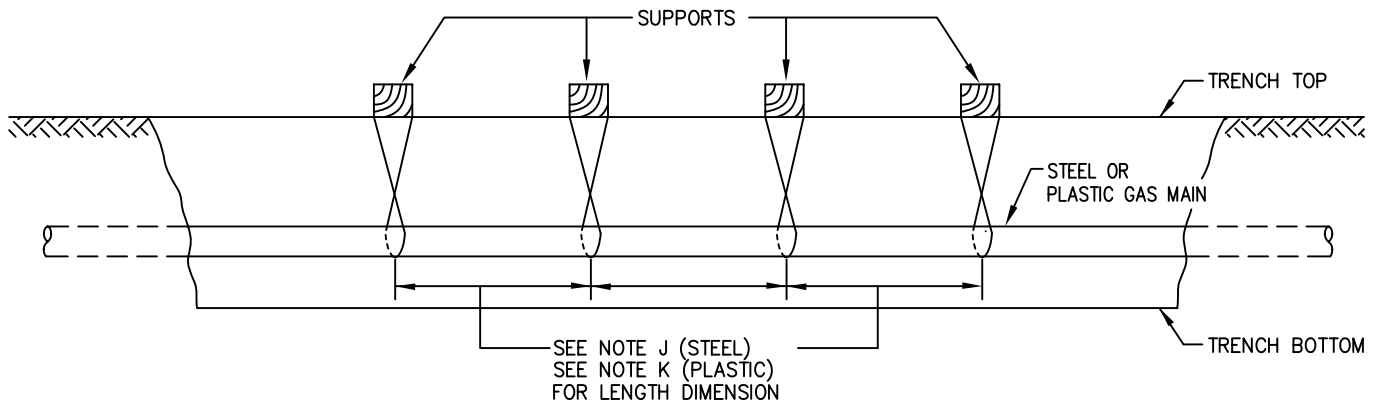

SUPPORTED LENGTH A-A

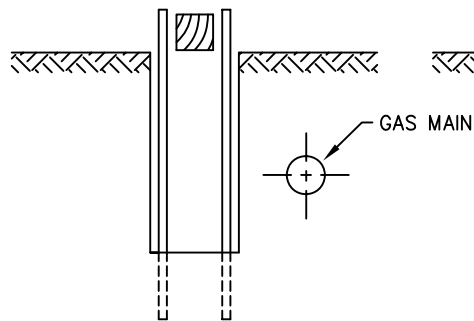

ADEQUATELY SHORED TRENCH

DETAIL A
SEE NOTE B

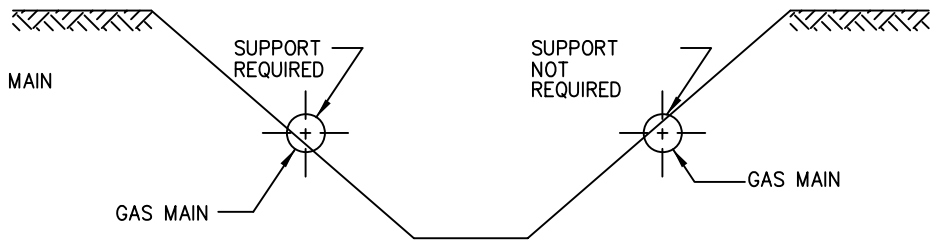

INADEQUATELY SHORED OR UNSHORED TRENCH

DETAIL B
SEE NOTE B

nationalgrid

LI-MA-NH-NYC

**SUPPORT REQUIREMENTS FOR
EXPOSED & UNDERMINED STEEL OR PLASTIC
GAS FACILITIES**

REVISIONS CLARIFIED NOTES B & C ADDED NOTE N.

DATE: 07/01/2003

EFFECTIVE DATE: 03/24/2006

DESIGN: A. GIULIANI

STD. DWG.

DRAWN: P. DIMAIO

NO.

CNST-6045

NOTES:

- A. THIS CONSTRUCTION STANDARD SHALL BE USED TO SUPPORT PLASTIC OR STEEL GAS FACILITIES WHICH ARE UNDERMINED AND EXPOSED BY CONSTRUCTION ACTIVITY.
- B. IF AN EXCAVATION IS MADE **AT ANY DISTANCE** PARALLEL TO THE GAS FACILITY WITH ADEQUATE **OSHA** STRUCTURAL SHORING, AS SHOWN IN DETAIL "A", OR IF A STABLE SOIL CONDITION WITH **SUFFICIENT COVER ABOVE THE PIPE'S CENTERLINE EXISTS**, AS SHOWN IN DETAIL "B", THEN SUPPORTS ARE NOT REQUIRED. **UNSTABLE SOIL IS DEFINED AS A SOIL WHICH CAN CAUSE "SOIL RUN OUT" FROM BENEATH THE PIPE (e.g., WASHOUT, SOFT CLAY, etc.) OR CAN SHIFT DUE TO CONSTRUCTION ACTIVITY, VIBRATIONS, etc.; AND CAUSE A SOIL SCENARIO TO OCCUR AS SHOWN IN DETAIL "B" TO REQUIRE PIPE SUPPORT.**
- C. IF AN EXCAVATION CROSSES OR RUNS PARALLEL TO A GAS FACILITY, SUPPORTS MAY NOT BE REQUIRED IF THE EXPOSED SECTION OF PLASTIC PIPES IS 3' OR LESS AND STEEL PIPES 7' OR LESS.
- D. ALL EXCAVATIONS SHALL BE PERFORMED IN ACCORDANCE WITH THE REQUIREMENTS OF THE **ONE CALL DIG SAFE PROGRAM** USING THE APPROPRIATE MARK OUT, TEST HOLES AND EXCAVATION TO AVOID DAMAGE TO PIPE OR PIPE COATINGS:
 - NEW YORK STATE CODE RULE 753
 - MA CHAPTER 82 - SECTION 40, GENERAL LAWS, REGULATING NOTICE REQUIREMENTS FOR EXCAVATION IN PUBLIC WAYS
 - NH DIG SAFE LAW, RSA 374 – REGULATING UNDERGROUND UTILITY DAMAGE PREVENTION SYSTEM
- E. USE OF THIS CONSTRUCTION STANDARD DOES NOT RELIEVE THE CONSTRUCTION AGENCY OR AUTHORITY OR THEIR RESPECTIVE CONTRACTORS OF RESPONSIBILITY FOR DAMAGES. ALL DAMAGES WILL BE REPAIRED IN ACCORDANCE WITH EXISTING STANDARDS AND THE APPROPRIATE PARTY SHALL BE BILLED FOR ALL EXPENSES.
- F. GAS FACILITIES SHOULD NOT BE UNDERMINED WITHOUT ADEQUATE SUPPORT (DETAIL A). ALL SUPPORT LINES SHALL BE TENSIONED SO THAT NO DEFLECTION WILL OCCUR WHEN THE FACILITY IS UNDERMINED. THIS TENSION SHALL BE CHECKED AT THE START AND END OF EACH DAY AND ADJUSTED AS NECESSARY.
- G. WHERE A COUPLING, GAS SERVICE, CLAMP, VALVE, DRIP LINE OR OTHER APPURTENANCE EXISTS ON THE EXPOSED SECTION OF MAIN, AN ADDITIONAL SUPPORT SHALL BE INSTALLED AT THE LOCATION.
- H. WHEN SUPPORTING AN EXPOSED FACILITY, THE PIPE COATING SHALL BE PROTECTED WITH ROCK SHIELD (ITEM ID 00301097), OR OTHER LIKE MATERIAL CUT TO A MINIMUM WIDTH OF ½ THE SUPPORTED PIPE DIAMETER. SUPPORT LINES SHALL BE A MINIMUM OF ¾" POLYPROPYLENE OR BETTER.
- I. SUPPORTS FOR GAS TRANSMISSION FACILITIES SHALL BE REVIEWED WITH GAS ENGINEERING PRIOR TO INSTALLATION.
- J. THE MAXIMUM SPACING BETWEEN SUPPORTS FOR STEEL FACILITIES SHALL BE AS FOLLOWS:
 - 7' SPACING FOR ¾" AND 1 ¼" STEEL
 - 10' SPACING FOR 2" STEEL
 - 15' SPACING FOR 3" AND 4" STEEL
 - 20' SPACING FOR 6" AND LARGER STEEL
- K. THE MAXIMUM SPACING BETWEEN SUPPORTS FOR PLASTIC FACILITIES SHALL BE AS FOLLOWS :
 - 3' SPACING FOR 2" AND SMALLER PLASTIC
 - 6' SPACING FOR 4" AND LARGER PLASTIC
- L. VIBRATING MACHINES ARE ALLOWED OVER STEEL OR PLASTIC FACILITIES WITH 24" OR GREATER COVER. HAND HELD MECHANICAL TAMPER IS ACCEPTABLE OVER ANY FACILITY WITH 12" OR GREATER COVER.
- M. WHEN CONSTRUCTION ACTIVITY IS COMPLETED, CLEAN FILL SHALL BE COMPACTED AROUND AND UNDER THE GAS FACILITY BEFORE REMOVING SUPPORTS.
- N. **SEE REGIONAL PBWK5010 PROCEDURES FOR REPLACEMENT REQUIREMENTS OF CAST IRON PIPE.**

No.	ITEM	CODE No.
BILL OF MATERIAL		

GUIDELINES FOR BACKFILL AND COMPACTION AROUND GAS PIPES

PERMANENT BACKFILL AND COMPACTION

DESCRIPTION

This work shall consist of backfilling and compacting all disturbed material at and around existing gas pipes and facilities. Size of pipe, material, length of exposed pipe, location of pipe, etc. will all follow the same set of Standards and Specifications stipulated by Nationalgrid Company. If design plans call for gas pipes to be exposed and supported (sheeting methods not used), then at the time of backfill, all disturbed material below the invert of the gas pipe shall be removed and replaced with suitable roadway or trench excavation material or bedding material. The contractor will not be allowed to replace this disturbed material with the same existing material if it has now been mixed with adjacent silty subsoil (clays) and fines. Well-graded gravel and sands will be used to replace the unsuitable material when no excess suitable material is available on site. Soils with high humus or mineral content should not be used to for backfill because they can promote electrolytic or bacterial attack.

Backfilling the gas pipe should begin immediately after the work in that location is complete. The region within 6" alongside and on top of the gas pipe shall be backfilled with padding sand (free of cinders, ash, and rock). In no case shall the material used for backfilling in this region contain any stones. Backfill shall consist of suitable materials (medium to coarse sands with little or no silts) placed in layers of not more than 8" to 12" after compaction.

Trench spoil material shall be suitable for backfilling above the padding material as long as rocks with a diameter larger than 3" are removed. The layers shall be mechanically compacted to the industry standard of 95% or until a density comparable to the unexcavated material is achieved. In some instances, flooding with water is an acceptable method of compaction but only if the back-fill material is clean, coarse, and adequate drainage is existent. The above specified backfill material is essential in order to attain the degree of compaction necessary to avoid future settlement.

Tracing Wire, if necessary, shall be installed 2" to 6" below Plastic gas pipes.

Warning Tape shall be installed approximately 12" above the gas pipe.

A minimum of 2" temporary pavement shall be applied over the trench as soon as possible.

Typical Utility Crossing and Trench Guidelines

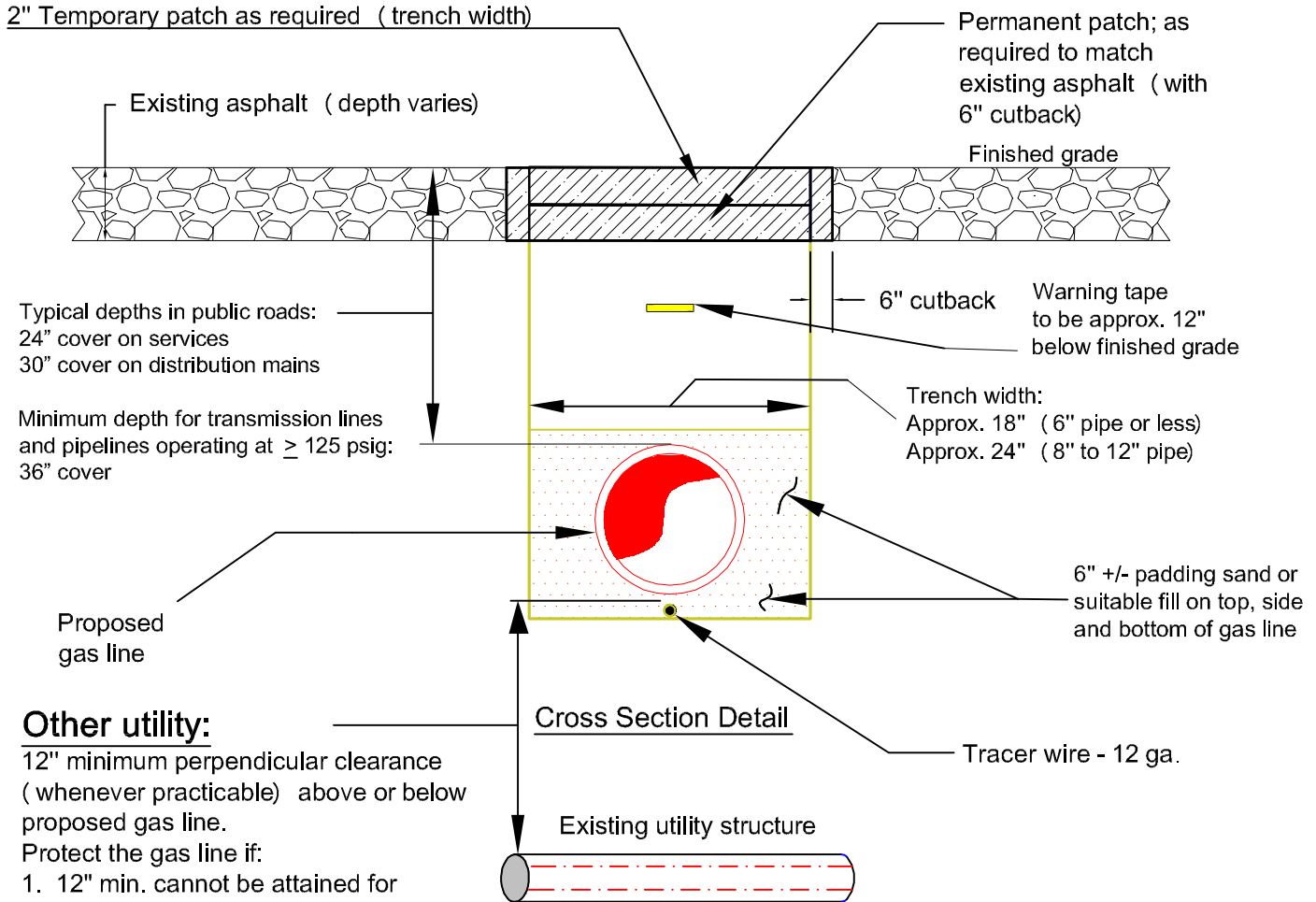

Other utility:

12" minimum perpendicular clearance (whenever practicable) above or below proposed gas line.

Protect the gas line if:

1. 12" min. cannot be attained for gas transmission lines and pipelines operating at ≥ 125 psig.
2. 6" min. cannot be attained for distribution mains.
3. 4" min. cannot be attained for services.

Minimum clearance when protection is provided against damage is 2" for all gas lines.

Pipeline backfill will consist of suitable materials (medium to coarse sands with little or no silts) placed in layers of no more than 8" to 12" after compaction. Trench spoil materials suitable for backfilling will be mechanically compacted to the industry standards of 95% (as measured by Drop-Cone Penetrometer method) or until a density comparable to the unexcavated material is achieved.

nationalgrid

RI

TYPICAL UTILITY CROSSING AND TRENCH GUIDELINES

DATE: 09/15/2014

EFFECTIVE DATE: 09/15/2014

DESIGN: N. COSTANZO

STD. DWG. NO.

DRAWN: N. COSTANZO

CS-CNST002

GUIDELINES FOR WORKING AROUND CORROSION CONTROL SYSTEM COMPONENTS

DESCRIPTION

This guideline shall control work around existing Corrosion Control components. Replacement of test stations, anodes and test wire leads shall comply with Standards and Specifications stipulated by Nationalgrid. If design plans call for work in the area of Corrosion Control components, care must be taken to prevent damage to such components.

GENERAL NATIONALGRID CONSIDERATIONS

The contractor shall perform replacement of damaged corrosion control test boxes, resetting of disturbed test boxes, and ensure a minimum of 12" of excess wire above the rim of the test box after set to finished grade. Wires shall not be pulled taught to achieve the 12" above the box, as this will cause stress on the wire connection at the main. Wires needing to be lengthened, damaged corrosion control components i.e. wires, or wire coating, shall require notification to the Corrosion Control Department (525-5610 or 474-5171) to initiate inspection/repair or replacement of the damaged components.

Backfilling exposed Corrosion Control wire components should begin immediately after the work in that location is complete. The region within 6" alongside and on top of the connector wires shall be backfilled with padding sand (free of cinders, ash, and rock). Test wire leads must be kept with enough slack to prevent stress on the points where the wires connect to the gas main. Trench spoil material shall be suitable for backfilling above the padding material as long as rocks with a diameter larger than 3" are removed. The 8" to 12" backfill layers shall be mechanically compacted to the industry standard of 95%.

Appendix N

City of Providence MBE WBE Forms

SECTION 00470

CITY OF PROVIDENCE
MBE/WBE
PARTICIPATION REQUIREMENTS

Providence Water / City of Providence

Minority & Women Business Enterprise Participation

MBE/WBE Form Instructions - Refer to Pages 10 & 11 in Section 00000 --- BCS Terms & Requirements for Bidding

MBE/WBE Participation Affidavit - Refer to Page 12 in Section 00000 --- BCS Terms & Requirements for Bidding

Subcontractor Disclosure Form - Refer to Page 13 in Section 00000 --- BCS Terms & Requirements for Bidding

MBE/WBE Waiver Request Form - Refer to Page 14 in Section 00000 --- BCS Terms & Requirements for Bidding

Periodic Utilization Reporting

Subcontractor Payment and Utilization Report

MBE/WBE Project Utilization Summary Form Sample -

MBE/WBE Project Utilization Summary Form

SUBCONTRACTOR PAYMENT AND UTILIZATION REPORT

This form is to be completed and submitted with your invoice to the department in accordance with any requirements (e.g. federal, state, etc.) associated with funding source. For projects with a duration of three months or less, this report should be submitted with request for final payment. This form should **NOT** be included as part of any bid or proposal.

Prime Contractor: _____

Item Description (as seen on RFP):

Original Contract Award Amount: _____

Revised Contract Award Amount (if applicable): _____

Instructions: Include all subcontractors listed on the Subcontractor Disclosure Form submitted with your original bid as well as any new subcontractors in the table below. If no payment has been issued during this period to a given subcontractor, write "\$0" in the "Amount Paid this Period" column.

If no payments were made to any subcontractors since your last invoice, please check here: ____

Subcontractor Company Name	Checks Made Payable To (if different from Company Name)	Amount Paid this Period
		\$
		\$
		\$
		\$
		\$
		\$

 Signature of Prime Contractor

 Printed Name

 Date Signed

For Office Use Only

For Fiscal Year _____ Quarter _____

Procurement # _____

**MBE/WBE
PROJECT UTILIZATION SUMMARY FORM**

Period: _____ to _____

Date Prepared: _____

Current Total Contract Value: _____

Period Expenditures

Item No.	General Contractor or Subcontractor	Activity Description	Project Goal		Non-M/WBE Contractor or Subcontractor \$ Amount	MBE Subcontractor \$ Amount	WBE Subcontractor \$ Amount	* % of Period Expend.	** % of Contract Value	Total Expenditure to date		Business Location Local (HQ)	State of Cert.
			\$ Value	%						\$ Amount	**%		
1													
2													
3													
4													
5													
6													
7													
8													
	TOTALS												
					Period Expenditure Total:								

Contract Value Distribution Goal:
 Total Contract Value: _____ 100%
 General Contractor: _____
 Sub (non-M/WBE): _____
 Sub MBE: _____
 Sub WBE: _____
 Total MBE/WBE: _____

Expenditures to Date:
 Total Expenditure to Date: _____
 General Contractor: _____
 Non-MBE/WBE Subs: _____
 MBE Subcontractors: _____
 WBE Subcontractors: _____
 Total MBE/WBE Subs: _____

Note: Individuals of Portuguese Origin are not Classified as Minorities by City of Providence.

 * % of Period Expenditure Total
 ** % of Current Total Contract Value

SAMPLE

MBE/WBE

PROJECT UTILIZATION SUMMARY FORM

Period: 11/1/2008 to 11/30/2008

Date Prepared: 12/10/08

Current Total Contract Value: \$4,000,000

Period Expenditures

Item No.	General Contractor or Subcontractor	Activity Description	Project Goal		Non-M/WBE Contractor or Subcontractor \$ Amount	MBE Subcontractor \$ Amount	WBE Subcontractor \$ Amount	* % of Period Expend.	** % of Contract Value	Total Expenditure to date		Business Location Local (HQ)	State of Cert.
			\$ Value	%						\$ Amount	**%		
1	XYZ Corporation	General Contractor	\$2,990,000	74.8%	\$220,000	\$0	\$0	61.1%	5.5%	\$350,000	8.8%	Smithfield, RI	RI
2	Smith Construction	Public LSRs, Permanent Paving	\$210,000	5.3%	\$30,000	\$0	\$0	8.3%	0.8%	\$45,000	1.1%	Cranston, RI	RI
3	Doe Enterprises	Private LSRs	\$150,000	3.8%	\$0	\$20,000	\$0	5.6%	0.5%	\$30,000	0.8%	Providence, RI	RI
4	Acme Paving	Roadway/Sidewalk Paving	\$250,000	6.3%	\$0	\$40,000	\$0	11.1%	1.0%	\$60,000	1.5%	Providence, RI	RI
5	Jones Equipment	Trucking/Hauling	\$100,000	2.5%	\$0	\$0	\$15,000	4.2%	0.4%	\$25,000	0.6%	Warwick, RI	RI
6	Brothers Barricades	Flaggers, Traffic Control	\$100,000	2.5%	\$0	\$0	\$20,000	5.6%	0.5%	\$35,000	0.9%	Smithfield, RI	RI
7	Zenith Industries	Asphalt Supplier	\$200,000	5.0%	\$0	\$0	\$15,000	4.2%	0.4%	\$30,000	0.8%	Lincoln, RI	RI
8			\$0	0.0%	\$0	\$0	\$0	0.0%	0.0%	\$0	0.0%		
	TOTALS		\$4,000,000	100.0%	\$250,000	\$60,000	\$50,000	100%	9.0%	\$575,000	14.4%		
Period Expenditure Total:							\$360,000	100%					

Contract Value Distribution Goal:

Total Contract Value:	\$4,000,000	100%
General Contractor:	\$2,990,000	75%
Sub (non-M/WBE):	\$210,000	5%
Sub MBE:	\$400,000	10%
Sub WBE:	\$400,000	10%
Total MBE/WBE:	\$800,000	20%

Expenditures to Date:

Total Expenditure to Date:	\$575,000	14.4%
General Contractor:	\$350,000	8.8%
Non-MBE/WBE Subs:	\$45,000	1.1%
MBE Subcontractors:	\$90,000	2.3%
WBE Subcontractors:	\$90,000	2.3%
Total MBE/WBE Subs:	\$180,000	4.5%

Note: Individuals of Portuguese Origin are not Classified as Minorities by City of Providence.

* % of Period Expenditure Total
 ** % of Current Total Contract Value

Appendix O

Apprentice Utilization, Local Hiring Requirements, and Air Quality Protocols

APPRENTICE UTILIZATION, LOCAL HIRING REQUIREMENTS, & AIR QUALITY PROTOCOLS

ARTICLE 1 - GENERAL

- A. The City of Providence has initiated, by Sections 21-28.1 and Section 2-169.1 of its Code of Ordinances, Apprentice Utilization / Local Hiring (First Source) requirements, and Air Quality Protocols.
- B. OSHA - 29 CFR 1926.1153, “Respirable Crystalline Silica Standard for Construction”, City of Providence Code of Ordinance Section 21-28.1, “Qualifications for Parties Doing Business with the City” and Section 2-169.1, “Local Hiring (First Source)” by inclusion and reference, shall be considered to be a part of this section.

ARTICLE 2 - APPRENTICE UTILIZATION

- A. Any and all bidders shall certify in writing, as a condition precedent for bidding on any City of Providence-sponsored project worth in excess of one hundred thousand dollars (\$100,000.00), that the bidder shall comply with the following.
- B. All CONTRACTORS and SUBCONTRACTORS shall be affiliated with a state registered apprenticeship program as defined in 29 C.F.R. § 29 et seq.
- C. No less than fifteen percent (15%) of the total labor hours performed by contractors and subcontractors on any one (1) project shall be completed by apprentices registered in state registered apprenticeship programs. This requirement pertains to all labor hours for a given project, not just those of new hires.
- D. Subsequent to the City's award of the contract and prior to commencement of work, the prime contractor may petition to adjust the apprenticeship work hour requirements in Article 2.2. The awarding agency may lower the fifteen (15) requirement only if it determines in writing that compliance is not feasible or that it would be unduly cost prohibitive to the project.
- E. All contractors and subcontractors shall submit written reports documenting compliance with their apprenticeship obligations prior to approval and issuance of any periodic and/or final payments being made by Providence Water, the contracting party.
- F. The following sanctions may be imposed on any contractor or subcontractor found not to be in compliance with its obligations under the Apprentice Utilization (AU) requirement. Such sanctions shall include, but not be limited to:
 - 1. Termination of contract.
 - 2. Debarment from future city projects.

3. Recovery of any benefits which accrued to the business during the period of violation.
4. Referral for civil sanctions and/or prosecution under the False Claims Act.

ARTICLE 3 – LOCAL HIRING (FIRST SOURCE PROVIDENCE)

- A. Jobs covered by this section and requiring adherence to the provisions of a first source agreement shall include all non-supervisory positions created as a result of internal promotions, terminations, and expansion of the employers workforce, except those filled by internal promotion from within the employers local workforce.
- B. The CONTRACTOR and all SUBCONTRACTORS shall agree to recruit and hire all covered employees from the first source list provided by First Source Providence. At least ten (10) days before hiring the CONTRACTOR/SUBCONTRACTOR shall notify First Source Providence who shall refer appropriately trained and qualified employees to said CONTRACTOR / SUBCONTRACTOR until the CONTRACTOR / SUBCONTRACTOR has filled such jobs.
- C. In the event that the CONTRACTOR / SUBCONTRACTOR is unable to find acceptable employees after exhausting the entire first source list, the CONTRACTOR / SUBCONTRACTOR shall notify First Source Providence that it wishes to seek outside employees. If after conference the CONTRACTOR / SUBCONTRACTOR and First Source Providence agree that the first source list is unable to provide suitable employees for said positions the CONTRACTOR / SUBCONTRACTOR shall be free to seek employees from other sources.
- D. If the CONTRACTOR / SUBCONTRACTOR and First Source Providence do not agree that First Source Providence is able to find suitable employees First Source Providence shall be given an additional thirty (30) days to recruit employees for said positions. If at the end of thirty (30) days First Source Providence is unable to provide suitable employees the CONTRACTOR / SUBCONTRACTOR shall be free to hire from other sources.
- E. CONTRACTOR and SUBCONTRACTOR shall notify First Source Providence as the “First Source” of referral. If the awarded contractors, regardless of tier, are signatory to Collective Bargaining Agreements which govern the contractors’ hiring and referral process, they shall contact both First Source Providence and the local hiring halls to request Providence resident Apprentices or Journey workers.
- F. Should the CONTRACTOR or SUBCONTRACTOR have difficulty securing registered apprentices who reside in Providence, or in general, please contact First Source Providence. If there are concerns that the project will not allow the CONTRACTOR or SUBCONTRACTOR to achieve the 15% AU requirement, contact Building Futures before commencing work.

- G. For questions regarding monthly reporting requirements and compliance with Apprentice Utilization or Local Hiring (First Source), contact Natalie Lopes, Director of First Source Providence at 401-680-8416 or via email at nlopes@providenceri.com.

ARTICLE 4 – AIR QUALITY PROTOCOLS

- A. Any and all bidders shall certify in writing, as a condition precedent for bidding on any City of Providence-sponsored project worth in excess of fifty thousand dollars (\$50,000.00), that the bidder shall comply with the following.
- B. All bidders shall adhere to air quality protocols outlined in the “Green During Construction” initiative. These refer specifically to:
1. The implementation of dust controls - especially silica control measures as defined in **OSHA Standard 29 CFR 1926.1153** - during construction;
 2. The substitution of all gasoline, propane, and diesel-powered construction equipment - either stationary and mobile - with equipment designed to reduce toxic emissions, either through engine modification, the use of alternative fuels, or the implementation of electric or hybrid power systems; and
 3. The prohibition of idling motors on gasoline and diesel vehicles as published by the Rhode Island Committee on Occupational Safety and Health.
- C. All bidders who are awarded or otherwise obtain contracts with the City of Providence shall comply with all obligations set forth in paragraph B. for the entire duration of the contract. Any bidder performing work pursuant to this initiative shall be obligated to immediately notify the City of Providence regarding any material changes relating to concurrence with this initiative. Failure to notify the city of any material change shall be considered a submission of false information and the city shall have the discretion to impose any and all sanctions authorized by this section.
- D. Any bidder who negligently or willfully fails or refuses to comply with any of the obligations set forth in paragraph B., above, for any period of time, shall be subject to sanctions at the discretion of the City of Providence, which may or may not include one (1) or more of the following:
1. Cessation of work on the project until compliance is obtained;
 2. Withholding of payment due under any contract or subcontract until compliance is obtained;
 3. Permanent removal from any further work on the project;
 4. Debarment from eligibility to contract with the City of Providence;
 5. Declaration of any contract held by the bidder null and void.
- E. Each bidder shall be responsible for, and shall ensure that any and all subcontractors to the bidder shall comply with all the requirements of the section, and each bidder shall certify the compliance of any and all subcontractors with the provisions of this section in the manner provided in paragraph D above.

END of SECTION

Appendix P

City of Providence Contract Terms and Conditions

**CITY OF PROVIDENCE
CONTRACT TERMS & CONDITIONS**

1. Termination of Contract for Cause. If through and cause, the Contractor shall fail to uphold any of the covenants, agreements, or stipulations of this Contract, the City of Providence shall thereupon have the right to terminate this Contract by giving written notice to the Contractor and specifying the effective date thereof, at least seven (7) days before the effective date of such termination. In such event, all finished or unfinished documents, data, studies, and reports prepared by the Contractor under this Contract, shall, at the option of the City of Providence, become City property and the Contractor shall be entitled to receive just and equitable compensation for any satisfactory work completed on such documents.

Notwithstanding the above, the Contractor shall not be relieved of liability to the City of Providence for damages sustained by the City of Providence by virtue of any breach of the Contract by the Contractor and the City of Providence may withhold any payments to the Contractor for the purpose of set off until such time as the exact amount of damages due the City of Providence from the Contractor is determined.

2. Termination for convenience of the City of Providence. The City of Providence may terminate this Contract any time by a notice in writing from the City of Providence to the Contractor. If the Contract is terminated by the City of Providence as provided herein, the Contractor will be paid an amount which bears the same ratio to the total compensation as the services actually performed. If this Contract is terminated due to the fault of the Contractor, Article 1 hereof relative to termination shall apply.

3. Changes. The City of Providence, may from time to time, request changes in the scope of the services of the Contractor to be performed hereupon. Such changes, including any increase or decrease in the amount of the Contract compensation, which are mutually agreed upon by and between the City of Providence and the Contractor shall be incorporated in written amendments to this Contract.

4. Personnel.

- a. The Contractor represents that it has, or will secure at its own expense, all personnel required in performing the services under this Contract. Such personnel shall not be employees of or have contractual relationship with the City of Providence.

- b. All the services required hereunder will be performed by the Contractor or under its supervision and all personnel engaged in the work shall be fully qualified and shall be authorized or permitted under State and local law to perform such services.
- c. No person who is serving sentences in a penal or Correctional institution shall be employed on work under this Contract.

5. Anti-Kickback Rules. Salaries of personnel performing work under this Contract shall except only such payroll deductions as are mandatory by law or permitted by the applicable regulation issued by the Secretary of Labor pursuant to the Copeland Act (or "Anti-Kickback Act of June 13, 1934 48 Stat. 948:62 Stat. 740:63 Stat. 108: Title 18 U.S.C. Section 874: and Title 40 U.S.C. Section 276(c). The Contractor shall comply with all applicable "Anti-Kickback" regulations and shall insert appropriate provisions in all subcontracts with such regulations, and shall be responsible for the submission of affidavits required of subcontractors thereunder except as the Secretary of Labor may specifically provide for variations of or exemptions from the requirements thereof.

6. Claims and Disputes Pertaining to Salary Rates. Claims and disputes pertaining to salary rates or to classifications of personnel performing work under this Contract shall be promptly reported in writing by the Contractor to the City of Providence for the latter's decision which shall be final with respect thereto.

7. Equal Employment Opportunity. During the performance of the Contract, the Contractor agrees as follows:

- a. The Contractor will not discriminate against any employee or applicant for employment because of race, color, religion, sex, country of national origin, age, ancestry or handicap. The Contractor will take affirmative action to ensure that applicants are employed, and that employees are treated during employment, without regard to race, religion, sex, country of national origin, age, ancestry or handicap. Such action will include, but not limited to the following: upgrading, demotion, or transfer, recruitment, or recruitment advertising, layoff or termination rates of pay or other forms of compensation, and selection for training, including apprenticeship. The Contractor agrees to post in conspicuous places, available to employees and applicants for employment, notices setting forth provisions of this nondiscrimination clause.

- b. The Contractor will, in all solicitation or advertisements for employees placed by or on behalf of the Contractor state that all qualified applicants will receive consideration for employment without regard to race, color, religion, sex country of national origin, age, ancestry or handicap.
- c. The Contractor will cause the foregoing provisions to be inserted in all subcontracts for any work covered by this Contract so that such provisions will be binding upon each subcontractor, provided that the foregoing provisions shall not apply to contracts or subcontracts for standard commercial supplies or raw materials.

8. Compliance with Local Laws. The Contractor shall comply with all laws, ordinances, and codes of the state and local governments, and shall commit no trespass on any public or private property in performing any of the work embraced by this contract.

9. Subcontracting. None of the services covered by this Contract shall be subcontracted without the prior written consent of the City of Providence. The Contractor shall be as fully responsible to the City of Providence for the acts and omissions of its/his subcontractors and of persons either directly employed by it/him. The Contractor shall insert in each subcontract appropriate provisions requiring compliance with the labor standards provisions of the Contract.

10. Assignability. The Contractor shall not assign any interest in this Contract, and shall not transfer any interest in the same (whether by or novation) without the prior written approval of the City of Providence; provided, however, that claims for money due or to become due the Contractor from the City of Providence, under this contract may be assigned to a bank, trust company, or other financial institution, or to a Trustee in Bankruptcy, without such approval.

11. Interest of Members of the City of Providence. No member of this governing body of the City of Providence and no other officer, employee, or agent of the City of Providence who exercises any functions or responsibilities in connection with the carrying out of the project to which this Contract pertains, shall have any personal interest, direct or indirect, in the Contract.

12. Findings Confidential. All of the reports, information, data, etc., prepared or assembled by the Contractor under this Contract are confidential and the Contractor agrees that they shall not be made available to any individual or organization without the prior written approval of the City of Providence.

13. Non-Expendable Property. At the conclusion of this Contract, all non-expendable property purchased with Contract funds shall revert to the City of Providence.

14. Records.

a. Establishment and Maintenance of Records. Records shall be maintained by the Contractor for a period of five years after the receipt of final payment under this contract.

1. Documentation of Costs. All costs shall be supported by properly executed payrolls, time records, invoices, contracts, or vouchers, or other documentation evidencing in proper detail the nature of and propriety of the charges. All checks, payrolls, invoices, contracts, vouchers, orders or other accounting documents pertaining in whole or in part to this Contract shall be clearly identified and readily accessible.

15. Audits and Inspections. At any time during normal business hours and as often as the City of Providence may deem necessary, there shall be made available by the Contractor to the City of Providence for examination all of its records with respect to all matters covered by this Contract. The Contractor will permit the City of Providence to audit, examine, and make excerpts of transcripts from such records, and to make audits of all contracts, invoices, materials, payrolls, records of personnel, conditions of employment, and other data or information relating to all matters covered by this Contract.

16. Political Activity Prohibited. None of the funds, materials, property or services provided directly or indirectly under this Contract shall be used for any partisan political activity, or to further the election or defeat of any candidate for public office, and shall be used solely for the performance of this Contract.

17. The Contractor shall, prior to commencing performance under the Contract, attach a Certificate of Insurance in a form and amount acceptable to the City of Providence, covering the damages which arise from the negligence of the Contractor in performance under the Contract, including all claims for personal injury or damages to property sustained by third persons, or their agents, servants and/or those claimed under them.

END OF EXHIBIT III

Appendix Q

Copland Act (29 CFR Part 3 Anti-Kickback Regulation)

This content is from the eCFR and is authoritative but unofficial.

Title 29 – Labor

Subtitle A – Office of the Secretary of Labor

Part 3 Contractors and Subcontractors on Public Building or Public Work Financed in Whole or in Part by Loans or Grants from the United States

- § 3.1 Purpose and scope.
- § 3.2 Definitions.
- § 3.3 Weekly statement with respect to payment of wages.
- § 3.4 Submission of weekly statements and the preservation and inspection of weekly payroll records.
- § 3.5 Payroll deductions permissible without application to or approval of the Secretary of Labor.
- § 3.6 Payroll deductions permissible with the approval of the Secretary of Labor.
- § 3.7 Applications for the approval of the Secretary of Labor.
- § 3.8 Action by the Secretary of Labor upon applications.
- § 3.9 Prohibited payroll deductions.
- § 3.10 Methods of payment of wages.
- § 3.11 Regulations part of contract.

PART 3—CONTRACTORS AND SUBCONTRACTORS ON PUBLIC BUILDING OR PUBLIC WORK FINANCED IN WHOLE OR IN PART BY LOANS OR GRANTS FROM THE UNITED STATES

Authority: R.S. 161, sec. 2, 48 Stat. 848; Reorg. Plan No. 14 of 1950, 64 Stat. 1267; 5 U.S.C. 301; 40 U.S.C. 3145; Secretary's Order 01–2014 (Dec. 19, 2014), 79 FR 77527 (Dec. 24, 2014).

Source: 29 FR 97, Jan. 4, 1964, unless otherwise noted.

§ 3.1 Purpose and scope.

This part prescribes “anti-kickback” regulations under section 2 of the Act of June 13, 1934, as amended (40 U.S.C. 276c), popularly known as the Copeland Act. This part applies to any contract which is subject to Federal wage standards and which is for the construction, prosecution, completion, or repair of public buildings, public works or buildings or works financed in whole or in part by loans or grants from the United States. The part is intended to aid in the enforcement of the minimum wage provisions of the Davis-Bacon Act and the various statutes dealing with federally assisted construction that contain similar minimum wage provisions, including those provisions which are not subject to Reorganization Plan No. 14 (e.g., the College Housing Act of 1950, the Federal Water Pollution Control Act, and the Housing Act of 1959), and in the enforcement of the overtime provisions of the Contract Work Hours Standards Act whenever they are applicable to construction work. The part details the obligation of contractors and

subcontractors relative to the weekly submission of statements regarding the wages paid on work covered thereby; sets forth the circumstances and procedures governing the making of payroll deductions from the wages of those employed on such work; and delineates the methods of payment permissible on such work.

§ 3.2 Definitions.

As used in the regulations in this part:

- (a) The terms *building* or *work* generally include construction activity as distinguished from manufacturing, furnishing of materials, or servicing and maintenance work. The terms include, without limitation, buildings, structures, and improvements of all types, such as bridges, dams, plants, highways, parkways, streets, subways, tunnels, sewers, mains, powerlines, pumping stations, railways, airports, terminals, docks, piers, wharves, ways, lighthouses, buoys, jetties, breakwaters, levees, and canals; dredging, shoring, scaffolding, drilling, blasting, excavating, clearing, and landscaping. Unless conducted in connection with and at the site of such a building or work as is described in the foregoing sentence, the manufacture or furnishing of materials, articles, supplies, or equipment (whether or not a Federal or State agency acquires title to such materials, articles, supplies, or equipment during the course of the manufacture or furnishing, or owns the materials from which they are manufactured or furnished) is not a *building* or *work* within the meaning of the regulations in this part.
- (b) The terms *construction*, *prosecution*, *completion*, or *repair* mean all types of work done on a particular building or work at the site thereof, including, without limitation, altering, remodeling, painting and decorating, the transporting of materials and supplies to or from the building or work by the employees of the construction contractor or construction subcontractor, and the manufacturing or furnishing of materials, articles, supplies, or equipment on the site of the building or work, by persons employed at the site by the contractor or subcontractor.
- (c) The terms *public building* or *public work* include building or work for whose construction, prosecution, completion, or repair, as defined above, a Federal agency is a contracting party, regardless of whether title thereof is in a Federal agency.
- (d) The term *building or work financed in whole or in part by loans or grants from the United States* includes building or work for whose construction, prosecution, completion, or repair, as defined above, payment or part payment is made directly or indirectly from funds provided by loans or grants by a Federal agency. The term includes building or work for which the Federal assistance granted is in the form of loan guarantees or insurance.
- (e) Every person paid by a contractor or subcontractor in any manner for his labor in the construction, prosecution, completion, or repair of a public building or public work or building or work financed in whole or in part by loans or grants from the United States is *employed* and receiving *wages*, regardless of any contractual relationship alleged to exist between him and the real employer.
- (f) The term *any affiliated person* includes a spouse, child, parent, or other close relative of the contractor or subcontractor; a partner or officer of the contractor or subcontractor; a corporation closely connected with the contractor or subcontractor as parent, subsidiary, or otherwise, and an officer or agent of such corporation.

- (g) The term *Federal agency* means the United States, the District of Columbia, and all executive departments, independent establishments, administrative agencies, and instrumentalities of the United States and of the District of Columbia, including corporations, all or substantially all of the stock of which is beneficially owned by the United States, by the District of Columbia, or any of the foregoing departments, establishments, agencies, and instrumentalities.

[29 FR 97, Jan. 4, 1964, as amended at 38 FR 32575, Nov. 27, 1973]

§ 3.3 Weekly statement with respect to payment of wages.

- (a) As used in this section, the term *employee* shall not apply to persons in classifications higher than that of laborer or mechanic and those who are the immediate supervisors of such employees.
- (b) Each contractor or subcontractor engaged in the construction, prosecution, completion, or repair of any public building or public work, or building or work financed in whole or in part by loans or grants from the United States, shall furnish each week a statement with respect to the wages paid each of its employees engaged on work covered by this part 3 and part 5 of this title during the preceding weekly payroll period. This statement shall be executed by the contractor or subcontractor or by an authorized officer or employee of the contractor or subcontractor who supervises the payment of wages, and shall be on the back of Form WH 347, "Payroll (For Contractors Optional Use)" or on any form with identical wording. Copies of WH 347 may be obtained from the Government contracting or sponsoring agency or from the Wage and Hour Division Web site at <http://www.dol.gov/whd/forms/index.htm> or its successor site.
- (c) The requirements of this section shall not apply to any contract of \$2,000 or less.
- (d) Upon a written finding by the head of a Federal agency, the Secretary of Labor may provide reasonable limitations, variations, tolerances, and exemptions from the requirements of this section subject to such conditions as the Secretary of Labor may specify.

[29 FR 97, Jan. 4, 1964, as amended at 33 FR 10186, July 17, 1968; 47 FR 23679, May 28, 1982; 73 FR 77511, Dec. 19, 2008; 82 FR 2224, Jan. 9, 2017]

§ 3.4 Submission of weekly statements and the preservation and inspection of weekly payroll records.

- (a) Each weekly statement required under § 3.3 shall be delivered by the contractor or subcontractor, within seven days after the regular payment date of the payroll period, to a representative of a Federal or State agency in charge at the site of the building or work, or, if there is no representative of a Federal or State agency at the site of the building or work, the statement shall be mailed by the contractor or subcontractor, within such time, to a Federal or State agency contracting for or financing the building or work. After such examination and check as may be made, such statement, or a copy thereof, shall be kept available, or shall be transmitted together with a report of any violation, in accordance with applicable procedures prescribed by the United States Department of Labor.
- (b) Each contractor or subcontractor shall preserve his weekly payroll records for a period of three years from date of completion of the contract. The payroll records shall set out accurately and completely the name and address of each laborer and mechanic, his correct classification, rate of pay, daily and weekly number of hours worked, deductions made, and actual wages paid. Such payroll records shall be made available at all times for inspection by the contracting officer or his authorized representative, and by authorized representatives of the Department of Labor.

(Reporting and recordkeeping requirements in paragraph (b) have been approved by the Office of Management and Budget under control number 1235-0008)

[29 FR 97, Jan. 4, 1964, as amended at 47 FR 145, Jan. 5, 1982; 82 FR 2224, Jan. 9, 2017]

§ 3.5 Payroll deductions permissible without application to or approval of the Secretary of Labor.

Deductions made under the circumstances or in the situations described in the paragraphs of this section may be made without application to and approval of the Secretary of Labor:

- (a) Any deduction made in compliance with the requirements of Federal, State, or local law, such as Federal or State withholding income taxes and Federal social security taxes.
- (b) Any deduction of sums previously paid to the employee as a bona fide prepayment of wages when such prepayment is made without discount or interest. A *bona fide prepayment of wages* is considered to have been made only when cash or its equivalent has been advanced to the person employed in such manner as to give him complete freedom of disposition of the advanced funds.
- (c) Any deduction of amounts required by court process to be paid to another, unless the deduction is in favor of the contractor, subcontractor, or any affiliated person, or when collusion or collaboration exists.
- (d) Any deduction constituting a contribution on behalf of the person employed to funds established by the employer or representatives of employees, or both, for the purpose of providing either from principal or income, or both, medical or hospital care, pensions or annuities on retirement, death benefits, compensation for injuries, illness, accidents, sickness, or disability, or for insurance to provide any of the foregoing, or unemployment benefits, vacation pay, savings accounts, or similar payments for the benefit of employees, their families and dependents: *Provided, however,* That the following standards are met:
 - (1) The deduction is not otherwise prohibited by law;
 - (2) It is either:
 - (i) Voluntarily consented to by the employee in writing and in advance of the period in which the work is to be done and such consent is not a condition either for the obtaining of or for the continuation of employment, or
 - (ii) provided for in a bona fide collective bargaining agreement between the contractor or subcontractor and representatives of its employees;
 - (3) No profit or other benefit is otherwise obtained, directly or indirectly, by the contractor or subcontractor or any affiliated person in the form of commission, dividend, or otherwise; and
 - (4) The deductions shall serve the convenience and interest of the employee.
- (e) Any deduction contributing toward the purchase of United States Defense Stamps and Bonds when voluntarily authorized by the employee.
- (f) Any deduction requested by the employee to enable him to repay loans to or to purchase shares in credit unions organized and operated in accordance with Federal and State credit union statutes.
- (g) Any deduction voluntarily authorized by the employee for the making of contributions to governmental or quasi-governmental agencies, such as the American Red Cross.

- (h) Any deduction voluntarily authorized by the employee for the making of contributions to Community Chests, United Givers Funds, and similar charitable organizations.
- (i) Any deductions to pay regular union initiation fees and membership dues, not including fines or special assessments: *Provided, however,* That a collective bargaining agreement between the contractor or subcontractor and representatives of its employees provides for such deductions and the deductions are not otherwise prohibited by law.
- (j) Any deduction not more than for the "reasonable cost" of board, lodging, or other facilities meeting the requirements of section 3(m) of the Fair Labor Standards Act of 1938, as amended, and part 531 of this title. When such a deduction is made the additional records required under § 516.25(a) of this title shall be kept.
- (k) Any deduction for the cost of safety equipment of nominal value purchased by the employee as his own property for his personal protection in his work, such as safety shoes, safety glasses, safety gloves, and hard hats, if such equipment is not required by law to be furnished by the employer, if such deduction is not violative of the Fair Labor Standards Act or prohibited by other law, if the cost on which the deduction is based does not exceed the actual cost to the employer where the equipment is purchased from him and does not include any direct or indirect monetary return to the employer where the equipment is purchased from a third person, and if the deduction is either
 - (1) Voluntarily consented to by the employee in writing and in advance of the period in which the work is to be done and such consent is not a condition either for the obtaining of employment or its continuance; or
 - (2) Provided for in a bona fide collective bargaining agreement between the contractor or subcontractor and representatives of its employees.

[29 FR 97, Jan. 4, 1964, as amended at 36 FR 9770, May 28, 1971]

§ 3.6 Payroll deductions permissible with the approval of the Secretary of Labor.

Any contractor or subcontractor may apply to the Secretary of Labor for permission to make any deduction not permitted under § 3.5. The Secretary may grant permission whenever he finds that:

- (a) The contractor, subcontractor, or any affiliated person does not make a profit or benefit directly or indirectly from the deduction either in the form of a commission, dividend, or otherwise;
- (b) The deduction is not otherwise prohibited by law;
- (c) The deduction is either
 - (1) voluntarily consented to by the employee in writing and in advance of the period in which the work is to be done and such consent is not a condition either for the obtaining of employment or its continuance, or
 - (2) provided for in a bona fide collective bargaining agreement between the contractor or subcontractor and representatives of its employees; and
- (d) The deduction serves the convenience and interest of the employee.

§ 3.7 Applications for the approval of the Secretary of Labor.

Any application for the making of payroll deductions under § 3.6 shall comply with the requirements prescribed in the following paragraphs of this section:

- (a) The application shall be in writing and shall be addressed to the Secretary of Labor.
- (b) The application need not identify the contract or contracts under which the work in question is to be performed. Permission will be given for deductions on all current and future contracts of the applicant for a period of 1 year. A renewal of permission to make such payroll deduction will be granted upon the submission of an application which makes reference to the original application, recites the date of the Secretary of Labor's approval of such deductions, states affirmatively that there is continued compliance with the standards set forth in the provisions of § 3.6, and specifies any conditions which have changed in regard to the payroll deductions.
- (c) The application shall state affirmatively that there is compliance with the standards set forth in the provisions of § 3.6. The affirmation shall be accompanied by a full statement of the facts indicating such compliance.
- (d) The application shall include a description of the proposed deduction, the purpose to be served thereby, and the classes of laborers or mechanics from whose wages the proposed deduction would be made.
- (e) The application shall state the name and business of any third person to whom any funds obtained from the proposed deductions are to be transmitted and the affiliation of such person, if any, with the applicant.

[29 FR 97, Jan. 4, 1964, as amended at 36 FR 9771, May 28, 1971]

§ 3.8 Action by the Secretary of Labor upon applications.

The Secretary of Labor shall decide whether or not the requested deduction is permissible under provisions of § 3.6; and shall notify the applicant in writing of his decision.

§ 3.9 Prohibited payroll deductions.

Deductions not elsewhere provided for by this part and which are not found to be permissible under § 3.6 are prohibited.

§ 3.10 Methods of payment of wages.

The payment of wages shall be by cash, negotiable instruments payable on demand, or the additional forms of compensation for which deductions are permissible under this part. No other methods of payment shall be recognized on work subject to the Copeland Act.

§ 3.11 Regulations part of contract.

All contracts made with respect to the construction, prosecution, completion, or repair of any public building or public work or building or work financed in whole or in part by loans or grants from the United States covered by the regulations in this part shall expressly bind the contractor or subcontractor to comply with such of the regulations in this part as may be applicable. In this regard, see § 5.5(a) of this subtitle.

Appendix R
Rhode Island Prevailing Wage Rates

"General Decision Number: RI20240001 01/05/2024

Superseded General Decision Number: RI20230001

State: Rhode Island

Construction Types: Building, Heavy (Heavy and Marine) and Highway

Counties: Rhode Island Statewide.

BUILDING CONSTRUCTION PROJECTS (does not include residential construction consisting of single family homes and apartments up to and including 4 stories) HEAVY, HIGHWAY AND MARINE CONSTRUCTION PROJECTS

Note: Contracts subject to the Davis-Bacon Act are generally required to pay at least the applicable minimum wage rate required under Executive Order 14026 or Executive Order 13658. Please note that these Executive Orders apply to covered contracts entered into by the federal government that are subject to the Davis-Bacon Act itself, but do not apply to contracts subject only to the Davis-Bacon Related Acts, including those set forth at 29 CFR 5.1(a)(1).

<p>If the contract is entered into on or after January 30, 2022, or the contract is renewed or extended (e.g., an option is exercised) on or after January 30, 2022:</p>	<ul style="list-style-type: none"> . Executive Order 14026 generally applies to the contract. . The contractor must pay all covered workers at least \$17.20 per hour (or the applicable wage rate listed on this wage determination, if it is higher) for all hours spent performing on the contract in 2024.
<p>If the contract was awarded on or between January 1, 2015 and January 29, 2022, and the contract is not renewed or extended on or after January 30, 2022:</p>	<ul style="list-style-type: none"> . Executive Order 13658 generally applies to the contract. . The contractor must pay all covered workers at least \$12.90 per hour (or the applicable wage rate listed on this wage determination, if it is higher) for all hours spent performing on that contract in 2024.

The applicable Executive Order minimum wage rate will be adjusted annually. If this contract is covered by one of the Executive Orders and a classification considered necessary for performance of work on the contract does not appear on this wage determination, the contractor must still submit a conformance request.

Additional information on contractor requirements and worker protections under the Executive Orders is available at <http://www.dol.gov/whd/govcontracts>.

Modification Number Publication Date
 0 01/05/2024

ASBE0006-006 09/01/2023

Rates Fringes

HAZARDOUS MATERIAL HANDLER
 (Includes preparation,
 wetting, stripping, removal
 scrapping, vacuuming, bagging
 & disposing of all insulation
 materials, whether they
 contain asbestos or not, from
 mechanical systems).....\$ 48.15 34.84

ASBE0006-008 09/01/2023

Rates Fringes

Asbestos Worker/Insulator
 Includes application of
 all insulating materials,
 protective coverings,
 coatings & finishes to all
 types of mechanical systems.\$ 48.15 34.84

BOIL0029-001 01/01/2021

Rates Fringes

BOILERMAKER.....\$ 45.87 29.02

BRII0003-001 06/01/2022

Rates Fringes

Bricklayer, Stonemason,
 Pointer, Caulker & Cleaner.....\$ 46.86 29.14

BRII0003-002 09/01/2022

Rates Fringes

Marble Setter, Terrazzo
 Worker & Tile Setter.....\$ 46.54 30.34

BRII0003-003 09/01/2022

Rates Fringes

Marble, Tile & Terrazzo
 Finisher.....\$ 38.78 29.61

CARP0330-001 06/05/2023

Rates Fringes

CARPENTER (Includes Soft
 Floor Layer).....\$ 42.78 30.00
 Diver Tender.....\$ 43.78 30.00
 DIVER.....\$ 55.93 30.00
 Piledriver.....\$ 41.53 29.35
 WELDER.....\$ 43.78 30.00

FOOTNOTES:

When not diving or tending the diver, the diver and diver tender shall receive the piledriver rate. Diver tenders shall receive \$1.00 per hour above the pile driver rate when tending the diver.

Work on free-standing stacks, concrete silos & public utility electrical power houses, which are over 35 ft. in height when constructed: \$.50 per hour additional.

Work on exterior concrete shear wall gang forms, 45 ft. or more above ground elevation or on setback: \$.50 per hour additional.

The designated piledriver, known as the "monkey": \$1.00 per hour additional.

CARP1121-002 01/02/2023

	Rates	Fringes
MILLWRIGHT.....	\$ 41.54	30.73

ELEC0099-002 06/01/2023

	Rates	Fringes
ELECTRICIAN.....	\$ 48.61	50.44%
Teledata System Installer.....	\$ 36.46	11.59%+15.31

FOOTNOTES:

Work of a hazardous nature, or where the work height is 30 ft. or more from the floor, except when working OSHA-approved lifts: 20% per hour additional.

Work in tunnels below ground level in combined sewer outfall: 20% per hour additional.

ELEV0039-001 01/01/2023

	Rates	Fringes
ELEVATOR MECHANIC.....	\$ 59.36	37.335+a+b

FOOTNOTES:

a. PAID HOLIDAYS: New Years Day; Memorial Day; Independence Day; Labor Day; Veterans' Day; Thanksgiving Day; the Friday after Thanksgiving Day; and Christmas Day.

b. Employer contributes 8% basic hourly rate for 5 years or more of service of 6% basic hourly rate for 6 months to 5 years of service as vacation pay credit.

ENGI0057-001 06/01/2023

	Rates	Fringes
Operating Engineer: (power		

plants, sewer treatment
plants, pumping stations,
tunnels, caissons, piers,
docks, bridges, wind
turbines, subterranean &
other marine and heavy
construction work)

GROUP 1.....	\$ 45.55	29.45
GROUP 2.....	\$ 43.55	29.45
GROUP 3.....	\$ 39.17	29.45
GROUP 4.....	\$ 36.32	29.45
GROUP 5.....	\$ 42.60	29.45
GROUP 6.....	\$ 33.40	29.45
GROUP 7.....	\$ 27.40	29.45
GROUP 8.....	\$ 39.25	29.45
GROUP 9.....	\$ 43.17	29.45

a. BOOM LENGTHS, INCLUDING JIBS:

- 150 feet and over + \$ 2.00
- 180 feet and over + \$ 3.00
- 210 feet and over + \$ 4.00
- 240 feet and over + \$ 5.00
- 270 feet and over + \$ 7.00
- 300 feet and over + \$ 8.00
- 350 feet and over + \$ 9.00
- 400 feet and over + \$10.00

a. PAID HOLIDAYS:

New Year's Day, President's Day, Memorial Day, July Fourth, Victory Day, Labor Day, Columbus Day, Veterans Day, Thanksgiving Day, Christmas Day. a: Any employee who works 3 days in the week in which a holiday falls shall be paid for the holiday.

a. FOOTNOTES:

Hazmat work: \$2.00 per hour additional.
Tunnel/Shaft work: \$5.00 per hour additional.

POWER EQUIPMENT OPERATORS CLASSIFICATIONS

GROUP 1: Cranes, lighters, boom trucks and derricks

GROUP 2: Digging machine, Ross Carrier, locomotive, hoist, elevator, bidwell-type machine, shot & water blasting machine, paver, spreader, graders, front end loader (3 yds. and over), vibratory hammer & vacuum truck, roadheaders, forklifts, economobile type equipment, tunnel boring machines, concrete pump and on site concrete plants.

GROUP 3: Oilers on cranes.

GROUP 4: Oiler on crawler backhoe.

GROUP 5: Bulldozer, bobcats, skid steer loader, tractor, scraper, combination loader backhoe, roller, front end loader (less than 3 yds.), street and mobile-powered sweeper (3-yd. capacity), 8-ft. sweeper minimum 65 HP).

GROUP 6: Well-point installation crew.

GROUP 7: Utility Engineers and Signal Persons

GROUP 8: Heater, concrete mixer, stone crusher, welding

machine, generator and light plant, gas and electric driven pump and air compressor.

GROUP 9: Boat & tug operator.

ENGI0057-002 05/01/2023

	Rates	Fringes
Power Equipment Operator (highway construction projects; water and sewerline projects which are incidental to highway construction projects; and bridge projects that do not span water)		
GROUP 1.....	\$ 40.70	29.25
GROUP 2.....	\$ 33.40	29.25
GROUP 3.....	\$ 20.00	29.25
GROUP 4.....	\$ 33.98	29.25
GROUP 5.....	\$ 37.68	29.25
GROUP 6.....	\$ 37.68	29.25
GROUP 7.....	\$ 32.95	29.25
GROUP 8.....	\$ 32.33	29.25
GROUP 9.....	\$ 34.28	29.25

a. FOOTNOTE: a. Any employee who works three days in the week in which a holiday falls shall be paid for the holiday.

a. PAID HOLIDAYS: New Year's Day, President's Day, Memorial Day, July Fourth, Victory Day, Labor Day, Columbus Day, Veterans Day, Thanksgiving Day & Christmas Day.

POWER EQUIPMENT OPERATOR CLASSIFICATIONS

GROUP 1: Digging machine, crane, piledriver, lighter, locomotive, derrick, hoist, boom truck, John Henry's, directional drilling machine, cold planer, reclaimer, paver, spreader, grader, front end loader (3 yds. and over), vacuum truck, test boring machine operator, veemere saw, water blaster, hydro-demolition robot, forklift, economobile, Ross Carrier, concrete pump operator and boats

GROUP 2: Well point installation crew

GROUP 3: Utility engineers and signal persons

GROUP 4: Oiler on cranes

GROUP 5: Combination loader backhoe, front end loader (less than 3 yds.), forklift, bulldozers & scrapers and boats

GROUP 6: Roller, skid steer loaders, street sweeper

GROUP 7: Gas and electric drive heater, concrete mixer, light plant, welding machine, pump & compressor

GROUP 8: Stone crusher

GROUP 9: Mechanic & welder

ENGI0057-003 06/01/2023

BUILDING CONSTRUCTION

	Rates	Fringes
Power Equipment Operator		
GROUP 1.....	\$ 44.82	29.90
GROUP 2.....	\$ 42.82	29.90
GROUP 3.....	\$ 42.60	29.90
GROUP 4.....	\$ 38.60	29.90
GROUP 5.....	\$ 35.75	29.90
GROUP 6.....	\$ 41.90	29.90
GROUP 7.....	\$ 41.47	29.90
GROUP 8.....	\$ 38.79	29.90

a. BOOM LENGTHS, INCLUDING JIBS:

150 ft. and over: + \$ 2.00
180 ft. and over: + \$ 3.00
210 ft. and over: + \$ 4.00
240 ft. and over: + \$ 5.00
270 ft. and over: + \$ 7.00
300 ft. and over: + \$ 8.00
350 ft. and over: + \$ 9.00
400 ft. and over: + \$10.00

a. PAID HOLIDAYS: New Year's Day, President's Day, Memorial Day, July Fourth, Victory Day, Labor Day, Columbus Day, Veterans Day, Thanksgiving Day & Christmas Day. a: Any employee who works 3 days in the week in which a holiday falls shall be paid for the holiday.

a. FOOTNOTE: Hazmat work: \$2.00 per hour additional.
Tunnel/Shaft work: \$5.00 per hour additional.

POWER EQUIPMENT OPERATORS CLASSIFICATIONS

GROUP 1: Cranes, lighters, boom trucks and derricks.

GROUP 2: Digging machine, Ross carrier, locomotive, hoist, elevator, bidwell-type machine, shot & water blasting machine, paver, spreader, front end loader (3 yds. and over), vibratory hammer and vacuum truck

GROUP 3: Telehandler equipment, forklift, concrete pump & on-site concrete plant

GROUP 4: Fireman & oiler on cranes

GROUP 5: Oiler on crawler backhoe

GROUP 6: Bulldozer, skid steer loaders, bobcats, tractor, grader, scraper, combination loader backhoe, roller, front end loader (less than 3 yds.), street and mobile powered sweeper (3 yds. capacity), 8-ft. sweeper (minimum 65 hp)

GROUP 7: Well point installation crew

GROUP 8: Heater, concrete mixer, stone crusher, welding machine, generator for light plant, gas and electric driven pump & air compressor

IRON0037-001 09/16/2023

	Rates	Fringes
IRONWORKER.....	\$ 40.00	32.58

LAB00271-001 11/27/2022

BUILDING CONSTRUCTION

	Rates	Fringes
LABORER		
GROUP 1.....	\$ 35.50	26.85
GROUP 2.....	\$ 35.75	26.85
GROUP 3.....	\$ 36.25	26.85
GROUP 4.....	\$ 36.50	26.85
GROUP 5.....	\$ 37.50	26.85

LABORERS CLASSIFICATIONS

GROUP 1: Laborer, Carpenter Tender, Mason Tender, Cement Finisher Tender, Scaffold Erector, Wrecking Laborer, Asbestos Removal [Non-Mechanical Systems]

GROUP 2: Asphalt Raker, Adzemen, Pipe Trench Bracer, Demolition Burner, Chain Saw Operator, Fence & Guard Rail Erector, Setter of Metal Forms for Roadways, Mortar Mixer, Pipelayer, Riprap & Dry Stonewall Builder, Highway Stone Spreader, Pneumatic Tool Operator, Wagon Drill Operator, Tree Trimmer, Barco-Type Jumping Tamper, Mechanical Grinder Operator

GROUP 3: Pre-Cast Floor & Roof Plank Erectors

GROUP 4: Air Track Operator, Hydraulic & Similar Self-Powered Drill, Block Paver, Rammer, Curb Setter, Powderman & Blaster

GROUP 5: Toxic Waste Remover

LABORERS CLASSIFICATIONS

GROUP 1: Laborer, Carpenter Tender, Mason Tender, Cement Finisher Tender, Scaffold Erector, Wrecking Laborer, Asbestos Removal [Non-Mechanical Systems]

GROUP 2: Asphalt Raker, Adzemen, Pipe Trench Bracer, Demolition Burner, Chain Saw Operator, Fence & Guard Rail Erector, Setter of Metal Forms for Roadways, Mortar Mixer, Pipelayer, Riprap & Dry Stonewall Builder, Highway Stone Spreader, Pneumatic Tool Operator, Wagon Drill Operator, Tree Trimmer, Barco-Type Jumping Tamper, Mechanical Grinder Operator

GROUP 3: Pre-Cast Floor & Roof Plank Erectors

GROUP 4: Air Track Operator, Hydraulic & Similar Self-Powered Drill, Block Paver, Rammer, Curb Setter, Powderman & Blaster

GROUP 5: Toxic Waste Remover

LAB00271-002 11/27/2022

HEAVY AND HIGHWAY CONSTRUCTION

	Rates	Fringes
LABORER		

COMPRESSED AIR		
Group 1.....	\$ 55.40	24.15
Group 2.....	\$ 52.93	24.15
Group 3.....	\$ 42.45	24.15
FREE AIR		
Group 1.....	\$ 44.05	24.15
Free Air		
Group 1.....	\$ 46.00	24.15
FREE AIR		
Group 2.....	\$ 43.05	24.15
Free Air		
Group 2.....	\$ 45.00	24.15
FREE AIR		
Group 3.....	\$ 40.50	24.15
Free Air		
Group 3.....	\$ 42.45	24.15
LABORER		
Group 1.....	\$ 35.50	24.85
Group 2.....	\$ 35.75	24.85
Group 3.....	\$ 36.50	24.85
Group 4.....	\$ 29.00	24.85
Group 5.....	\$ 37.50	24.85
OPEN AIR CAISSON, UNDERPINNING WORK AND BORING CREW		
Bottom Man.....	\$ 41.50	24.15
Top Man & Laborer.....	\$ 35.60	24.15
TEST BORING		
Driller.....	\$ 41.95	24.15
Laborer.....	\$ 41.95	24.15
LABORER CLASSIFICATIONS		

GROUP 1: Laborer; Carpenter tender; Cement finisher tender; Wrecking laborer; Asbestos removers [non-mechanical systems]; Plant laborer; Driller in quarries

GROUP 2: Adzeperson; Asphalt raker; Barcotype jumping tamper; Chain saw operators; Concrete and power buggy operator; Concrete saw operator; Demolition burner; Fence and guard rail erector; Highway stone spreader; Laser beam operator; Mechanical grinder operator; Mason tender; Mortar mixer; Pneumatic tool operator; Riprap and dry stonewall builder; Scaffold erector; Setter of metal forms for roadways; Wagon drill operator; Wood chipper operator; Pipelayer; Pipe trench bracer

GROUP 3: Air track drill operator; Hydraulic and similar powered drills; Brick paver; Block paver; Rammer and curb setter; Powderperson and blaster

GROUP 4: Flagger & signaler

GROUP 5: Toxic waste remover

LABORER - COMPRESSED AIR CLASSIFICATIONS

GROUP 1: Mucking machine operator, tunnel laborer, brake person, track person, miner, grout person, lock tender, gauge tender, miner: motor person & all others in compressed air

GROUP 2: Change house attendant, powder watchperson, top person on iron

GROUP 3: Hazardous waste work within the ""HOT"" zone

LABORER - FREE AIR CLASSIFICATIONS

GROUP 1: Grout person - pumps, brake person, track person, form mover & stripper (wood & steel), shaft laborer, laborer topside, outside motorperson, miner, conveyor operator, miner welder, heading motorperson, erecting operator, mucking machine operator, nozzle person, rodperson, safety miner, shaft & tunnel, steel & rodperson, mole nipper, concrete worker, form erector (wood, steel and all accessories), cement finisher (this type of work only), top signal person, bottom person (when heading is 50' from shaft), burner, shield operator and TBM operator

GROUP 2: Change house attendant, powder watchperson

GROUP 3: Hazardous waste work within the ""HOT"" zone

LABORER CLASSIFICATIONS

GROUP 1: Laborer; Carpenter tender; Cement finisher tender; Wrecking laborer; Asbestos removers [non-mechanical systems]; Plant laborer; Driller in quarries

GROUP 2: Adzeperson; Asphalt raker; Barcotype jumping tamper; Chain saw operators; Concrete and power buggy operator; Concrete saw operator; Demolition burner; Fence and guard rail erector; Highway stone spreader; Laser beam operator; Mechanical grinder operator; Mason tender; Mortar mixer; Pneumatic tool operator; Riprap and dry stonewall builder; Scaffold erector; Setter of metal forms for roadways; Wagon drill operator; Wood chipper operator; Pipelayer; Pipe trench bracer

GROUP 3: Air track drill operator; Hydraulic and similar powered drills; Brick paver; Block paver; Rammer and curb setter; Powderperson and blaster

GROUP 4: Flagger & signaler

GROUP 5: Toxic waste remover

LABORER - COMPRESSED AIR CLASSIFICATIONS

GROUP 1: Mucking machine operator, tunnel laborer, brake person, track person, miner, grout person, lock tender, gauge tender, miner: motor person & all others in compressed air

GROUP 2: Change house attendant, powder watchperson, top person on iron

GROUP 3: Hazardous waste work within the ""HOT"" zone

LABORER - FREE AIR CLASSIFICATIONS

GROUP 1: Grout person - pumps, brake person, track person, form mover & stripper (wood & steel), shaft laborer, laborer topside, outside motorperson, miner, conveyor operator, miner welder, heading motorperson, erecting operator, mucking machine operator, nozzle person, rodperson, safety miner, shaft & tunnel, steel & rodperson, mole nipper, concrete worker, form erector (wood, steel and all accessories), cement finisher (this type of work only), top signal person, bottom person (when heading is 50' from

shaft), burner, shield operator and TBM operator

GROUP 2: Change house attendant, powder watchperson

GROUP 3: Hazardous waste work within the ""HOT"" zone

PAIN0011-005 06/01/2023

	Rates	Fringes
PAINTER		
Brush and Roller.....	\$ 37.62	22.85
Epoxy, Tanks, Towers, Swing Stage & Structural Steel.....	\$ 39.62	22.85
Spray, Sand & Water Blasting.....	\$ 40.62	22.85
Taper.....	\$ 38.37	22.85
Wall Coverer.....	\$ 38.12	22.85

PAIN0011-006 06/01/2022

	Rates	Fringes
GLAZIER.....	\$ 40.78	23.40

FOOTNOTES:

SWING STAGE: \$1.00 per hour additional.

PAID HOLIDAYS: Labor Day & Christmas Day.

PAIN0011-011 06/01/2023

	Rates	Fringes
Painter (Bridge Work).....	\$ 56.25	23.45

PAIN0035-008 06/01/2011

	Rates	Fringes
Sign Painter.....	\$ 24.79	13.72

PLAS0040-001 06/05/2023

BUILDING CONSTRUCTION

	Rates	Fringes
CEMENT MASON/CONCRETE FINISHER...	\$ 42.77	29.63

FOOTNOTE: Cement Mason: Work on free swinging scaffolds under 3 planks width and which is 20 or more feet above ground and any offset structure: \$.30 per hour additional.

PLAS0040-002 07/01/2023

HEAVY AND HIGHWAY CONSTRUCTION

	Rates	Fringes
--	-------	---------

CEMENT MASON/CONCRETE FINISHER...\$ 37.45 24.85

PLAS0040-003 06/05/2023

Rates Fringes

PLASTERER.....\$ 42.77 29.63

PLUM0051-002 08/28/2023

Rates Fringes

Plumbers and Pipefitters.....\$ 50.59 32.75

ROOF0033-004 12/01/2023

Rates Fringes

ROOFER.....\$ 43.80 30.31

SFRI0669-001 04/01/2023

Rates Fringes

SPRINKLER FITTER.....\$ 47.55 32.27

SHEE0017-002 12/01/2020

Rates Fringes

Sheet Metal Worker.....\$ 38.58 36.73

TEAM0251-001 05/01/2023

HEAVY AND HIGHWAY CONSTRUCTION

Rates Fringes

TRUCK DRIVER

GROUP 1.....	\$ 29.71	34.602+A+B
GROUP 2.....	\$ 29.86	34.602+A+B
GROUP 3.....	\$ 29.91	34.602+A+B
GROUP 4.....	\$ 29.96	34.602+A+B
GROUP 5.....	\$ 30.06	34.602+A+B
GROUP 6.....	\$ 30.46	34.602+A+B
GROUP 7.....	\$ 30.66	34.602+A+B
GROUP 8.....	\$ 30.16	34.602+A+B
GROUP 9.....	\$ 30.41	34.602+A+B
GROUP 10.....	\$ 30.21	34.602+A+B

FOOTNOTES:

A. Paid Holidays: New Year's Day, Memorial Day, Independence Day, Labor Day, Thanksgiving Day and Christmas Day, plus Presidents' Day, Columbus Day, Veteran's Day & V-J Day, providing the employee has worked at least one day in the calendar week in which the holiday falls.

B. Employee who has been on the payroll for 1 year or more but less than 5 years and has worked 150 Days during the last year of employment shall receive 1 week's paid vacation; 5 to 10 years - 2 weeks' paid vacation; 10 or more years - 3 week's paid vacation.

C. Employees on the seniority list shall be paid a one

hundred dollar (\$100.00) bonus for every four hundred (400) hours worked, up to a maximum of five hundred dollars (\$500.00)

All drivers working on a defined hazard material job site shall be paid a premium of \$2.00 per hour over applicable rate.

TRUCK DRIVER CLASSIFICATIONS

GROUP 1: Pick-up trucks, station wagons, & panel trucks

GROUP 2: Two-axle on low beds

GROUP 3: Two-axle dump truck

GROUP 4: Three-axle dump truck

GROUP 5: Four- and five-axle equipment

GROUP 6: Low-bed or boom trailer.

GROUP 7: Trailers when used on a double hook up (pulling 2 trailers)

GROUP 8: Special earth-moving equipment, under 35 tons

GROUP 9: Special earth-moving equipment, 35 tons or over

GROUP 10: Tractor trailer

WELDERS - Receive rate prescribed for craft performing operation to which welding is incidental.

=====
Note: Executive Order (EO) 13706, Establishing Paid Sick Leave for Federal Contractors applies to all contracts subject to the Davis-Bacon Act for which the contract is awarded (and any solicitation was issued) on or after January 1, 2017. If this contract is covered by the EO, the contractor must provide employees with 1 hour of paid sick leave for every 30 hours they work, up to 56 hours of paid sick leave each year. Employees must be permitted to use paid sick leave for their own illness, injury or other health-related needs, including preventive care; to assist a family member (or person who is like family to the employee) who is ill, injured, or has other health-related needs, including preventive care; or for reasons resulting from, or to assist a family member (or person who is like family to the employee) who is a victim of, domestic violence, sexual assault, or stalking. Additional information on contractor requirements and worker protections under the EO is available at <https://www.dol.gov/agencies/whd/government-contracts>.

Unlisted classifications needed for work not included within the scope of the classifications listed may be added after award only as provided in the labor standards contract clauses (29CFR 5.5 (a) (1) (iii)).

The body of each wage determination lists the classification and wage rates that have been found to be prevailing for the cited type(s) of construction in the area covered by the wage determination. The classifications are listed in alphabetical order of ""identifiers"" that indicate whether the particular rate is a union rate (current union negotiated rate for local), a survey rate (weighted average rate) or a union average rate (weighted union average rate).

Union Rate Identifiers

A four letter classification abbreviation identifier enclosed in dotted lines beginning with characters other than ""SU"" or ""UAVG"" denotes that the union classification and rate were prevailing for that classification in the survey. Example: PLUM0198-005 07/01/2014. PLUM is an abbreviation identifier of the union which prevailed in the survey for this classification, which in this example would be Plumbers. 0198 indicates the local union number or district council number where applicable, i.e., Plumbers Local 0198. The next number, 005 in the example, is an internal number used in processing the wage determination. 07/01/2014 is the effective date of the most current negotiated rate, which in this example is July 1, 2014.

Union prevailing wage rates are updated to reflect all rate changes in the collective bargaining agreement (CBA) governing this classification and rate.

Survey Rate Identifiers

Classifications listed under the ""SU"" identifier indicate that no one rate prevailed for this classification in the survey and the published rate is derived by computing a weighted average rate based on all the rates reported in the survey for that classification. As this weighted average rate includes all rates reported in the survey, it may include both union and non-union rates. Example: SULA2012-007 5/13/2014. SU indicates the rates are survey rates based on a weighted average calculation of rates and are not majority rates. LA indicates the State of Louisiana. 2012 is the year of survey on which these classifications and rates are based. The next number, 007 in the example, is an internal number used in producing the wage determination. 5/13/2014 indicates the survey completion date for the classifications and rates under that identifier.

Survey wage rates are not updated and remain in effect until a new survey is conducted.

Union Average Rate Identifiers

Classification(s) listed under the UAVG identifier indicate that no single majority rate prevailed for those classifications; however, 100% of the data reported for the classifications was union data. EXAMPLE: UAVG-OH-0010 08/29/2014. UAVG indicates that the rate is a weighted union average rate. OH indicates the state. The next number, 0010 in the example, is an internal number used in producing the wage determination. 08/29/2014 indicates the survey completion date for the classifications and rates under that identifier.

A UAVG rate will be updated once a year, usually in January of each year, to reflect a weighted average of the current negotiated/CBA rate of the union locals from which the rate is

based.

WAGE DETERMINATION APPEALS PROCESS

1.) Has there been an initial decision in the matter? This can be:

- * an existing published wage determination
- * a survey underlying a wage determination
- * a Wage and Hour Division letter setting forth a position on a wage determination matter
- * a conformance (additional classification and rate) ruling

On survey related matters, initial contact, including requests for summaries of surveys, should be with the Wage and Hour National Office because National Office has responsibility for the Davis-Bacon survey program. If the response from this initial contact is not satisfactory, then the process described in 2.) and 3.) should be followed.

With regard to any other matter not yet ripe for the formal process described here, initial contact should be with the Branch of Construction Wage Determinations. Write to:

Branch of Construction Wage Determinations
Wage and Hour Division
U.S. Department of Labor
200 Constitution Avenue, N.W.
Washington, DC 20210

2.) If the answer to the question in 1.) is yes, then an interested party (those affected by the action) can request review and reconsideration from the Wage and Hour Administrator (See 29 CFR Part 1.8 and 29 CFR Part 7). Write to:

Wage and Hour Administrator
U.S. Department of Labor
200 Constitution Avenue, N.W.
Washington, DC 20210

The request should be accompanied by a full statement of the interested party's position and by any information (wage payment data, project description, area practice material, etc.) that the requestor considers relevant to the issue.

3.) If the decision of the Administrator is not favorable, an interested party may appeal directly to the Administrative Review Board (formerly the Wage Appeals Board). Write to:

Administrative Review Board
U.S. Department of Labor
200 Constitution Avenue, N.W.
Washington, DC 20210

4.) All decisions by the Administrative Review Board are final.

=====
END OF GENERAL DECISION"

Appendix S
Build America, Buy America Act
Implementation Procedures



UNITED STATES ENVIRONMENTAL PROTECTION AGENCY
WASHINGTON, D.C. 20460

OFFICE OF WATER

November 3, 2022

MEMORANDUM

SUBJECT: Build America, Buy America Act Implementation Procedures for EPA Office of Water Federal Financial Assistance Programs

FROM: Radhika Fox
Assistant Administrator

A handwritten signature in black ink, appearing to be "R. Fox", is written over the name and title of the sender.

TO: EPA Regional Water Division Directors, Regions I – X
EPA Office of Water Office Directors

OVERVIEW

The Biden-Harris Administration recognized the Nation's critical need for infrastructure investment, championing the Bipartisan Infrastructure Law (BIL), which Congress passed on November 15, 2021 (also known as the Infrastructure Investment and Jobs Act (IIJA)). The BIL will provide an unprecedented level of federal investment in water and wastewater infrastructure in communities across America.

In Title IX of the IIJA, Congress passed the Build America, Buy America (BABA) Act, which establishes strong and permanent domestic sourcing requirements across all Federal financial assistance programs for infrastructure. The U.S. Environmental Protection Agency (EPA) Office of Water is honored to help lead the implementation of these provisions and is proud of its near decade of successful implementation of the American Iron and Steel (AIS) provisions for its flagship water infrastructure programs.

This is a transformational opportunity to build a resilient supply chain and manufacturing base for critical products here in the United States that will spur investment in good-paying American manufacturing jobs and businesses. EPA's efforts to implement BABA will help cultivate the domestic manufacturing base for a wide range of products commonly used across the water sector but not currently made domestically. This will take time, and flexibility will be important to ensure that EPA can leverage critical water investments on time and on budget to protect public health and improve water quality.

IMPLEMENTATION

Recognizing the opportunity and need for BABA implementation guidance, the Made in America Office (MIAO) of the Office of Management and Budget (OMB) published [Initial Implementation Guidance on Application of Buy America Preference in Federal Financial Assistance Programs for Infrastructure](#) (OMB Guidance M-22-11) on April 18, 2022. The guidance provides government-wide implementation direction for all Federal financial assistance programs for infrastructure. Despite the extensive guidance developed by MIAO, EPA's Office of Water infrastructure investment programs have received many questions that were not addressed in OMB Guidance M-22-11 or that require further clarification for EPA water infrastructure programs. The following questions and answers serve to supplement OMB Guidance M-22-11 with implementation procedures specific to EPA's relevant water infrastructure programs.

Section 70914(a) of the IIJA states when a Buy America preference under BABA applies: "Not later than... [May 14, 2022], the head of each Federal agency shall ensure that none of the funds made available for a Federal financial assistance program for infrastructure...may be obligated for a project unless all of the iron, steel, manufactured products, and construction materials used in the project are produced in the United States." Therefore, Federal financial infrastructure investments obligated on or after May 14, 2022, must comply with the BABA requirements. Absent a waiver, all iron, steel, manufactured products, and construction materials permanently incorporated into an infrastructure project subject to the BABA requirements must be produced in the United States. For many of EPA's Office of Water infrastructure investment programs, the vast majority of products permanently incorporated into construction, maintenance, or repair projects must comply with the BABA requirements, with the exception of select construction materials (cement and cementitious materials; aggregates such as stone, sand, or gravel; or aggregate binding agents or additives), which are specifically exempted by the BABA statute.

EPA's Office of Water implements many infrastructure investment programs subject to BABA requirements, including the following:

- Alaska Native Villages and Rural Communities Water Grant Program (ANV) (and any associated Interagency Agreements with the Indian Health Service)
- Clean Water and Drinking Water State Revolving Fund Programs (CW and DWSRF)
- Clean Water and Drinking Water Grants to U.S. Territories and the District of Columbia
- Clean Water Indian and Drinking Water Tribal Infrastructure Grant Set-aside (and any associated Interagency Agreements with the Indian Health Service)
- Coastal Wetlands Planning, Protection and Restoration Act, (CWPPRA) Programs
- Congressionally Directed Spending/Community Project Funding (also known as Community Grants)
- Geographic Programs¹
- Gulf Hypoxia Program
- National Estuaries Program (CWA Section 320)

¹ Geographic Programs include: Great Lakes Restoration Initiative, Chesapeake Bay, San Francisco Bay, Puget Sound, Long Island Sound, Gulf of Mexico, South Florida, Lake Champlain, Lake Pontchartrain, Southern New England Estuaries, Columbia River Basin, Pacific Northwest

- 319 Nonpoint Source Management Program Implementation
- Reducing Lead in Drinking Water Grant Program (SDWA §1459B)
- Assistance for Small and Disadvantaged Communities Grants: Small, Underserved, and Disadvantaged Community Grant Program (SUDC), Emerging Contaminants in Small or Disadvantaged Communities (EC-SDC) and Drinking Water Infrastructure Resilience & Sustainability (SDWA §1459A)
- Sewer Overflow and Stormwater Reuse Municipal Grants (OSG)
- USMCA Implementing Legislation (Section 821 and Title IX, USMCA Supplemental Appropriations, 2020)
- U.S.-Mexico Border Water Infrastructure Program
- Voluntary School and Child Care Program Lead Testing and Remediation Grant Program (SDWA 1464(d))
- Water Infrastructure Finance and Innovation Act (WIFIA)

The questions and answers in this document apply to the implementation of BABA requirements for the Office of Water infrastructure programs listed above unless superseded by regulation, statute, or other applicable guidance. For many of the programs listed above which did not have domestic preference requirements prior to BABA, additional implementation details are pending or may be developed after the issuance of these procedures. In addition, EPA notes that more direction will be helpful to inform the determination and definition of domestic content in manufactured goods. Supplemental guidance on these and other issues, from either OMB or EPA, may be forthcoming. These implementation procedures may also apply to additional, unlisted EPA programs which may be required to apply BABA subsequent to publication of this memorandum (e.g., future funding programs which have been authorized, but not yet appropriated).

For more information on the BABA requirements, visit the EPA Office of Water’s dedicated website – <https://www.epa.gov/cwsrf/build-america-buy-america-baba> – or contact your funding authority (such as your grants officer, portfolio manager, or state contact). For information on approved waivers, visit <https://www.epa.gov/cwsrf/build-america-buy-america-baba-approved-waivers>. You may also email questions to BABA-OW@epa.gov.

This Implementation Procedures document is organized to provide responses to questions in the following topic areas:

- Section 1: General..... 4
- Section 2: Product Coverage..... 5
- Section 3: Co-funding 9
- Section 4: Waivers 10
- Section 5: Documenting Compliance 12
- Section 6: Programs with American Iron and Steel Requirements..... 16
- Section 7: Program-Specific Issues 17
- Appendix 1: Example Build America, Buy America (BABA) Act Construction Contract Language..... 22
- Appendix 2: Example Build America, Buy America (BABA) Act Assistance Agreement Language..... 23

QUESTIONS AND ANSWERS

SECTION 1: GENERAL

- Q1.1: Will EPA provide documentation for BABA for bid solicitations and suggested contract language? Will EPA provide suggested language for Assistance Agreements?
 - A1.1: See Appendix 1, which includes suggested language for construction contracts which addresses the BABA requirements. In addition to the language suggested in Appendix 1, EPA also recommends that assistance recipients prepare contract bid solicitation documents with a statement for the consulting engineers and construction firms as follows: “By signing payment application and recommending payment, Contractor certifies they have reviewed documentation for all products and materials submitted for payment, and the certifications are sufficient to demonstrate compliance with Build America, Buy America Act requirements.” In most cases, the assistance recipient’s representatives assume the responsibility for their clients to conduct due diligence on compliance with applicable domestic preference requirements.

All Federal Financial infrastructure assistance agreements subject to BABA must have a clause requiring compliance with the requirements. See Appendix 2 for example assistance agreement language.

- Q1.2: Would federally-financed infrastructure projects outside of the United States need to comply with the BABA requirements?
 - A1.2: No. According to the OMB Guidance (M-22-11), a “project” is defined as “...any activity related to the construction, alteration, maintenance, or repair of infrastructure in the United States.” Therefore, the BABA requirements are not implicated for infrastructure projects occurring outside of the United States, such as projects funded through the United States-Mexico-Canada Agreement with infrastructure activities occurring in Mexico or Canada (that is, outside the United States).
 -
- Q1.3: If most of the project is BABA compliant, and a small portion is not, can an assistance recipient self-fund (i.e., paying with non-federal dollars) the non-compliant products?
 - A1.3: Any project that is funded in whole or in part with federal assistance must comply with the BABA requirements, unless the requirements are otherwise waived. All iron, steel, manufactured products, and construction materials used in a project must meet the BABA requirements unless waived. Absent a waiver, there is no “small portion” or product that does not need to satisfy the BABA requirements unless the requirements are waived (or specifically excluded as is the case for cement and cementitious materials; aggregates such as stone, sand, or gravel; aggregate binding agents or additives; or non-permanent products). An assistance recipient may request a waiver or inquire as to whether a broad waiver, such as a *de minimis* waiver, might apply.

- Q1.4: How do international trade agreements affect the implementation of the BABA requirements?
 - A1.4: The BABA requirements apply in a manner consistent with United States obligations under international trade agreements. Typically, these obligations only apply to direct procurement by the entities that are signatories to these trade agreements. In general, assistance recipients are not signatories to such agreements, so these trade agreements have no impact on BABA implementation. In the few instances where such an agreement applies to a municipality, that municipality is responsible for determining its applicability and requirements and communicating with the funding authority (such as EPA and/or a state) on the actions taken to comply with BABA.

SECTION 2: PRODUCT COVERAGE

- Q2.1: For products made of iron and steel, what is the difference between predominantly and primarily iron and steel?
 - A2.1: EPA considers the terms “predominantly” and “primarily” to be interchangeable, such that a product is considered predominantly (or primarily) iron and steel if it contains greater than 50 percent iron and steel by material cost.
- Q2.2: What is the definition of construction materials (with examples)?
 - A2.2: From OMB Guidance M-22-11: “construction materials” include an article, material, or supply (other than an item of primarily iron or steel; a manufactured product; cement and cementitious materials; aggregates such as stone, sand, or gravel; aggregate binding agents or additives; or non-permanent products) that is or consists primarily of:
 - non-ferrous metals,
 - plastic and polymer-based products (including polyvinylchloride, composite building materials, and polymers used in fiber optic cables), (including optic glass),
 - lumber, and
 - drywall.

For example, a plate of glass would be a construction material under BABA, but a framed window that incorporates the glass into a frame would be a manufactured product. Another common construction material for water infrastructure projects would be polyvinyl chloride (PVC) pipe and fittings. However, if PVC components are incorporated into a more complex product such as instrumentation and control equipment or a water treatment unit, those items would be manufactured products.

- Q2.3: What are manufactured products (with examples)?
 - A2.3: From OMB Guidance M-22-11: “...all manufactured products used in the project are produced in the United States—this means the manufactured product was manufactured in the United States; and the cost of the components of the manufactured product that are mined, produced, or manufactured in the United States is greater than 55 percent of the total

cost of all components of the manufactured product, unless another standard for determining the minimum amount of domestic content of the manufactured product has been established under applicable law or regulation...”

The manufactured products category would cover the majority of potential water infrastructure products, including complex products made up of a variety of material types and components. For water infrastructure projects, common manufactured products would include, but not be limited to, pumps, motors, blowers, aerators, generators, instrumentation and control systems, gauges, meters, measurement equipment, treatment equipment, dewatering equipment, actuators, and many other mechanical and electrical items.

- Q2.4: Which category will valves fall under for BABA? Will it differ from the American Iron and Steel (AIS) requirements?
 - A2.4: For programs that are subject to BABA and AIS (SRF, WIFIA, and Community Project Funding), projects using valves should classify them as iron and steel products under BABA as long as their material cost is made up of more than 50 percent iron and/or steel. Valves with 50 percent or less iron and/or steel by material cost would be considered manufactured products under the BABA requirements.

In accordance with OMB Guidance M-22-11, an article, material, or supply should be classified into only one of the three categories: iron and steel, manufactured products, or construction materials. Under the AIS requirements, all valves made primarily of iron and steel (that is, those with iron and/or steel material cost greater than 50 percent) must comply with the AIS requirements. For BABA, EPA interprets Section IV of OMB Guidance M-22-11 to mean that iron and steel products are those items that are primarily iron and steel, the same as for the AIS requirements.

- Q2.5: Does EPA have a list of products to be classified as “Iron and Steel” under BABA?
 - A2.5: Although this list is not comprehensive, the following products were classified as AIS products if made primarily (more than 50 percent) of iron and/or steel by materials cost (for programs subject to both AIS and BABA, this list would be equivalent for “iron and steel” items or products under either requirement):

Products likely made “primarily” of iron and steel to be classified as <u>Iron and Steel</u> under BABA		
Lined and Unlined Pipe	Lined and Unlined Fittings	Tanks
Flanges	Pipe Clamps and Restraints	Structural Steel
Valves	Hydrants	Pre-Cast, Iron/Steel Reinforced Concrete (of all types, regardless of iron/steel content percentage)
Manhole Covers and other Municipal Castings	Access Hatches	Ballast Screens
Iron or Steel Benches	Bollards	Cast Bases
Cast Iron Hinged Hatches	Cast Iron Riser Rings	Catch Basin Inlets
Cleanout/Monument Boxes	Construction Covers and Frames	Curb and Corner Guards

Products likely made “primarily” of iron and steel to be classified as <u>Iron and Steel</u> under BABA		
Curb Boxes	Curb Openings	Curb Stops
Detectable Warning Plates	Downspout Shoes	Drainage Grates
Drainage Grate Frames and Curb Inlets	Inlets	Junction Boxes
Lampposts	Manhole Rings and Frames	Manhole Risers
Meter Boxes	Service Boxes	Steel Hinged Hatches
Steel Riser Rings	Trash Receptacles	Tree Grates
Tree Guards	Trench Grates	Valve Boxes
Valve Box Covers and Risers	Access Ramps	Aeration Pipes and Fittings (separate from aeration/blowers)
Angles	Backflow Preventers/Double Check Valves	Baffle Curtains
Iron or Steel Bar	Bathroom Stalls	Beam Clamps
Cable Hanging Systems	Clarifier Tanks	Coiled Steel
Column Piping	Concrete Reinforcing Bar, Wire, and Fibers	Condensate Sediment Traps
Corrugated Pipe	Couplings	Decking
Digester Covers	Dome Structures	Door Hardware
Doors	Ductwork	Expansion Joints
Expansion Tanks (diaphragm, surge, and hydropneumatics)	Fasteners	Fencing and Fence Tubing
Fire Escapes	Flanged Pipe	Flap Gates
Framing	Gate Valves	Generic Hanging Brackets
Grating	Ground Testing Boxes	Ground Test Wells
Guardrails	HVAC Registers, Diffusers, and Grilles	Joists
Knife Gates	Ladders	Lifting Hooks, J-bar, Connectors within, and Anchors for Concrete
Lockers	Man Baskets and Material Platforms	Manhole Steps
Mud Valves	Municipal Casting Junctions	Non-mechanical (aka stationary) Louvers and Dampers
Overhead Rolling Doors/ Uplifting Doors (manual open, no motor)	Pipe Connectors	Pipe Hangers
Pipe Pilings (any type of steel piling)	Pipe Spool (pipe, flanges, connectors, etc.)	Pipe Supports
Pitless Adaptors	Pre-fab Steel Buildings/Sheds (simple structure, unfurnished)	Pre-stressed Concrete Cylinder Pipe (PCCP)
Railings	Reduced Pressure Zone (RPZ) Valves	Roofing
Service Saddles	Sheet Piling	Sinks (not part of eyewash systems)
Solenoid Valves	Stairs	Static Mixers
Stationary Screens	Surface Drains	Tapping Sleeves
Telescoping Valves	Tipping Buckets	Trusses
Tubing	Valve Stem Extensions	Valve Stems (excluding handwheels and actuators)
Wall Panels	Wall Sleeves/Floor Sleeves	Welding Rods
Well Casing	Well Screens	Wire
Wire Cloth	Wire Rod	Wire Rope and Cables

Q2.6: Does EPA have a list of products that could be made “primarily” of iron and steel but would be classified as “manufactured products” under BABA?

A2.6: Although this list is not comprehensive, the following products would be considered “manufactured products” under the BABA requirements, even if the item might be composed primarily of iron and steel by materials cost (Note: These items are not subject to the AIS requirements.):

Products likely made “primarily” of iron and steel to be classified as <u>Manufactured Products</u> under BABA		
Actuator Superstructures/ Support Structures	Aeration Nozzles and Injectors	Aerators
Analytical Instrumentation	Analyzers (e.g., ozone, oxygen)	Automated Water Fill Stations
Blowers/Aeration Equipment	Boilers, Boiler Systems	Chemical Feed Systems (e.g., polymer, coagulant, treatment chemicals)
Chemical Injection Quills	Chemical Injectors	Clarifier Mechanisms/Arms
Compressors	Controls and Switches	Conveyors
Cranes	Desiccant Air Dryer Tanks	Dewatering Equipment
Dewatering Roll-offs	Disinfection Systems	Drives (e.g., variable frequency drives)
Electric/Pneumatic/Manual Accessories Used to Operate Valves (such as electric valve actuators)	Electrical Cabinetry and Housings (such as electrical boxes/enclosures)	Electrical Conduit
Electrical Junction Boxes	Electronic Door Locks	Elevator Systems (hydraulic, etc.,)
Emergency Life Systems (including eyewash stations, emergency safety showers, fire extinguishers, fire suppression systems including sprinklers /piping/valves, first aid, etc.)	Exhaust Fans	Fall Protection Anchor Points
Fiberglass Tank w/Appurtenances	Filters (and appurtenances, including underdrains, backwash systems)	Flocculators
Fluidized Bed Incinerators	Galvanized Anodes/Cathodic Protection	Gear Reducers
Generators	Geothermal Systems	Grinders
Heat Exchangers	HVAC (excluding ductwork)	HVAC Dampers (if appurtenances to aerators/blowers)
HVAC Louvers (mechanical)	Intake and Exhaust Grates (if appurtenances to aerators/blowers)	Instrumentation
Laboratory Equipment	Ladder Fall Prevention Systems	Ladder Safety Posts
Lighting Fixtures	Lightning and Grounding Rods	Mechanical or Actuated Louvers/Dampers
Membrane Bioreactor Systems	Membrane Filtration Systems	Metal Office Furniture (fixed)
Meters (including flow, wholesale, water, and service connection)	Motorized Doors (unit)	Motorized Mixers
Motorized Screens (such as traveling screens)	Motors	Pelton Wheels
Pipeline Flash Reactors (similar to injectors)	Plate Settlers	Precast Concrete without Iron/Steel Reinforcement

Products likely made “primarily” of iron and steel to be classified as <u>Manufactured Products</u> under BABA		
Furnished Pre-fab Buildings (such as furnished with pumps, mechanics inside)	Presses (including belt presses)	Pressure Gauges
Pump Cans/Barrels and Strainers	Pumps	Mechanical Rakes
Safety Climb Cable	Sampling Stations (unless also act as hydrant)	Scrubbers
Sensors	Sequencing Batch Reactors (SBR)	Steel Shelving (fixed)
Slide and Sluice Gates	Spray Header Units	Steel Cabinets (fixed interior/furniture)
Supervisory Control and Data Acquisition (SCADA) Systems	Tracer Wire	Valve Manual Gears, Actuators, Handles
Voltage Transformer	Water Electrostatic Precipitators (WESP)	Water Heaters
Weir Gates		

- Q2.7: Is asphalt paving a covered product under BABA?
 - A2.7: No. EPA interprets Section 70917(c) of the IJJA to exclude asphalt from BABA requirements. Asphalt paving is a type of concrete composed of an aggregate material mixed with a binder (bitumen). EPA considers asphalt concrete to be excluded by section 70917(c) due to its similarities with cement and cementitious materials.

SECTION 3: CO-FUNDING

- Q3.1: If projects are co-funded with funding mechanisms that don’t require BABA, must the entire project comply with BABA?
 - A3.1: Yes. Any project that is funded in whole or in part with federal assistance must comply with the BABA requirements, unless the requirements are otherwise waived. A “project” consists of all construction necessary to complete the building or work regardless of the number of contracts or assistance agreements involved so long as all the contracts and assistance agreements awarded are closely related in purpose, time, and place. This precludes the intentional splitting of projects into separate and smaller contracts or assistance agreements to avoid BABA’s applicability on some portions of a larger project, particularly where the activities are integrally and proximately related to the whole. However, there are many situations in which major construction activities are clearly undertaken in separate phases that are distinct in purpose, time, or place, in which case, separate contracts or assistance agreements would carry separate requirements.

- Q3.2: How will project requirements be determined for co-funded projects subject to potentially different general applicability/programmatic waiver conditions (such as different adjustment period waivers)?
 - A3.2: OMB Guidance M-22-11 addresses cases with project co-funding from separate programs. EPA would apply the guidance’s “cognizant” program determination to projects that are co-funded with different general applicability/programmatic waivers. For instance, if a project were co-funded between WIFIA and SRF and the majority of the Federal funding for the project is from WIFIA, then WIFIA would be the “cognizant” program for application and determination of waivers. In that case, any conditions from an applicable WIFIA waiver would apply.

SECTION 4: WAIVERS

- Q4.1: Who may apply for a waiver and how do you apply?
 - A4.1: Assistance recipients and their authorized representatives may apply for a project-specific waiver. EPA does not accept waiver requests from suppliers, distributors, or manufacturers unless the assistance recipient endorses and submits the request on its own behalf to the funding authority. In the case where multiple programs are providing federal funds to the project, the assistance recipient should submit the waiver request to the cognizant program, the one providing the greatest amount of federal funds for the project. For information on applying for cost waivers, see questions 4.4 and 4.5. For information on the SRF program roles and responsibilities, see question 7.6.

Project-specific waiver requests should generally include: (1) a brief summary of the project, (2) a description and explanation of the need for the waiver for the product(s) in question, (3) a brief summary of the due diligence conducted in search of domestic alternatives (which could include correspondence between assistance recipient and supplier/distributors), (4) the quantity and materials of the product(s) in question, (5) all engineering specifications and project design considerations relevant to the product(s) in question, (6) the approximate unit cost of items (both foreign and domestic) in addition to an estimated cost of the materials and overall project, (7) the date any products will be needed on site in order to avoid significant project schedule disruptions, and (8) any other pertinent information relevant to EPA’s consideration of the waiver (e.g., if relevant for SRF projects: whether the project is designated as an equivalency project, the date the plans and specifications were submitted to the state, the date of construction initiation, expected date of project completion, any special considerations such as local zoning and building ordinances, seismic requirements, or noise or odor control requirements).

In the case of indirect federal assistance, such as the SRF programs, the state authority reviews and conveys the waiver request to EPA. States should submit waiver requests to the appropriate program waiver request inbox. For SRF projects, please use CWSRFWaiver@epa.gov or DWSRFWaiver@epa.gov.

- Q4.2: Can an assistance recipient request a waiver based on a specification written for a specific brand or model of product (that is, a specification that names a branded item or model)?
 - A4.2: In most cases, performance-based specifications are expected and required for the majority of infrastructure projects funded by EPA’s financial assistance programs. In rare cases where “branded” or product-specific sourcing may be included in project specifications, it is suggested that the specifications include the item in question (that is, not simply a catalog page, but also materials of construction, sizing, quantities, and applicable engineering performance design characteristics for the project, etc.) in addition to the standard phrase “or equal.” For the purposes of product alternative market research, EPA will evaluate the BABA requirements based on performance-based engineering specifications for the product(s) in question. If the project’s specifications do not include performance-based specifications, or at least an “or equal” designation, EPA will base its research on an “or equal” designation using best professional judgment to the extent practicable.

- Q4.3: If a manufactured product is not readily available domestically, will EPA provide short-term “limited availability” product waivers?
 - A4.3: EPA will address the unavailability of domestic products through the waiver process, including potential national short-term waivers for specific products, if appropriate. To the extent practicable and with the intent to maximize domestic market and supply chain development, EPA intends to address issues of broad product unavailability with targeted, time-limited, and conditional waivers, as prescribed in OMB Guidance M-22-11. EPA will follow its robust and thorough product research processes (those put into place for the AIS requirements for the SRF and WIFIA programs and expanded for the new BABA requirements) to identify and determine those products for which proposed national/general applicability waivers may be appropriate.

- Q4.4: What information is needed when applying for a cost waiver under BABA?
 - A4.4: As part of the cost waiver request, the assistance recipient must demonstrate that implementation of the BABA requirements will increase the overall project cost more than 25 percent. Depending on the circumstances of the overall project cost increases, documentation to justify the cost waiver can vary but may include itemized cost estimates or bid tabulations comparing project costs with and without BABA implementation. Assistance recipients should begin assessing the potential cost impacts of the BABA requirements during the design phase of a project.

- Q4.5: Can administrative costs associated with tracking and verification of certifications be considered when determining if the cost of a project increases by 25 percent or more?
 - A4.5: Yes. Section 70914(b)(3) of the IIJA states that a waiver may be provided if the overall cost of the project increases by more than 25 percent due to the “inclusion of iron, steel, manufactured products, or construction materials produced in the United States.” EPA interprets this to mean that the “inclusion” of the BABA-covered products could encompass

reasonable administrative costs associated with complying with the BABA requirements, such as staff, contractor, and technological resources to collect and track BABA compliance documentation.

- Q4.6: How can assistance recipients and construction contractors address product delivery delays?
 - A4.6: Assistance recipients should reasonably plan for material procurement to account for known potential supply chain issues or extended lead times and shall notify the funding authority well in advance of the issues so that prompt attention can be given to explore options. Where extended lead times for compliant products are impacting project schedules and may significantly impact construction progress, timely communication with the funding agency is important. For products that are unavailable within a reasonable timeframe to meet the objectives and schedule of a project, EPA may consider a non-availability waiver with adequate justification. An assistance recipient would need to apply for the waiver and contact its funding authority (such as EPA and/or a state) to initiate the waiver process.

SECTION 5: DOCUMENTING COMPLIANCE

- Q5.1: Who will be responsible for BABA enforcement?
 - A5.1: Responsibility for BABA implementation applies at all levels, from manufacturers to suppliers and distributors, construction contractors, assistance recipients, and funding authorities.

The manufacturers have responsibility to provide adequate and accurate documentation of the products manufactured. If suppliers and distributors are involved, they are responsible for passing along compliance documentation for products supplied to projects that are subject to the BABA requirements.

The assistance recipient and their representatives are primarily responsible for ensuring the documentation collected for products used on the project is sufficient to document compliance with the BABA requirements.

The funding authority is responsible for providing oversight and guidance as needed to ensure the proper implementation of the requirements. The Uniform Grants Guidance (UGG) (Title 2 of the Code of Federal Regulations (CFR) Part 200) applies to many Federal financial assistance agreements that will include BABA requirements. The general provisions of 2 CFR Part 200 determine the responsible party for the grant funding authority.

For information on SRF program roles and responsibilities, see question 7.6.

At all levels, where fraud, waste, abuse, or any violation of the law is suspected, the Office of Inspector General (OIG) should be contacted immediately. The OIG can be reached at 1-888-546-8740 or OIG_Hotline@epa.gov. More information can be found at this website: <http://www.epa.gov/oig/hotline.htm>.

- Q5.2: When will the BABA requirements be assessed for compliance? Do assistance recipients need to have waivers for potential non-domestic products before assistance agreements are in place, at the time products are procured or products are incorporated into the project (i.e., used)?
 - A5.2: Compliance is assessed where the domestic product is used (or installed) at the project site. Proper compliance documentation, whether it is a BABA certification letter or a waiver, should accompany a product prior to its “use”, in accordance with Section 70914(a) of IIJA. This may occur prior to assistance agreements being in place but is not necessary. Additionally, communication of BABA requirements through appropriate Terms and Conditions in financial assistance agreements and in project solicitation and contract documents is key in ensuring all parties involved are informed of the requirements for the project before construction is underway.

- Q5.3: How can product compliance with the BABA requirements be demonstrated?
 - A5.3: Assistance recipients and their representatives should ensure that the products delivered to the construction site are accompanied by proper documentation that demonstrate compliance with the law and be made available to the funding authority upon request. The documentation may be received and maintained in hard copy, electronically, or could be embedded in construction management software. The use of a signed certification letter for the project is the most direct and effective form of compliance documentation for ensuring products used on site are BABA-compliant prior to their installation; however, other forms of documentation are also acceptable as long as collectively, the following can be demonstrated:
 - (1) Documentation linked to the project. For example, this can be in the form of the project name, project location, contract number, or project number.
 - (2) Documentation linked to the product used on the project. For example, description of product(s) (simple explanation sufficient to identify the product(s)), or an attached (or electronic link to) purchase order, invoice, or bill of lading.
 - (3) Documentation includes statement attesting that the products supplied to the assistance recipient are compliant with BABA requirement. Reference to the Infrastructure Investment and Jobs Act (“IIJA”) or the Bipartisan Infrastructure Law (BIL) are also acceptable. For iron and steel items under BABA, references to the American Iron and Steel (AIS) requirements are also acceptable and reciprocal with BABA for such items.
 - (4) Documentation that manufacturing occurred in the United States, which could include, for example, the location(s) of manufacturing for each manufacturing step that is being certified. It is acceptable for manufactured products to note a single point of manufacturing, documenting that the final point of manufacturing is in the United States. Note that each BABA category may require different determinations for compliance.
 - (5) Signature of company representative (on company letterhead and signature can be electronic). The signatory of the certifying statement affirms their knowledge of the manufacturing processes for the referenced product(s) and attests that the product meets the BABA requirements.

In addition to compliance documentation, assistance recipients or their representatives should also conduct a visual inspection of the product when it arrives to the project site, especially for iron and steel products which are often stamped with the country of origin. (Note: A country of origin stamp alone is not sufficient verification of compliance with BABA and assistance receipts should not rely on it to ensure compliance.)

EPA may develop alternative procedures for demonstrating compliance. Additional project- or program-specific instructions may be developed on a case-by-case basis in order to meet individual circumstances.

- Q5.4: Will EPA provide a form or template for tracking and documenting compliance?
 - A5.4: EPA does not require a specified format for tracking or documenting compliance. Assistance recipients are free to develop any system (from simple to complex software) for tracking items used on the project and the accompanying compliance documentation, e.g., certification letters, applicable waivers, if it helps with implementation and compliance. Elements that may help with keeping track of compliance may include: product description, quantity required/used, product category (i.e., iron and steel, manufactured product, or construction material), status of obtaining certification letter, product cost, and whether the item might qualify as *de minimis*, or qualify under another applicable waiver.
- Q5.5: If a manufacturer claims to comply with the Buy American Act, does it also comply with BABA?
 - A5.5: No. With the exception of the AIS requirements – which EPA interprets to be equivalent to the “iron and steel” requirements under BABA – EPA does not have an interpretation about the comparability of other domestic preference requirements relative to BABA. Any products that are to be certified as compliant with BABA should include a specific reference to the BABA requirements and appropriate attestation from a responsible manufacturing company official. See Question 5.3 for EPA’s recommendations for BABA certification letters.
- Q5.6: How will assistance recipients manage certification letters for hundreds, possibly thousands of products?
 - A5.6: EPA recognizes that the new BABA requirements will cover most products used in typical water and wastewater infrastructure projects, and that the number of items which may require certification at large and/or complex projects may reach several hundred. EPA is concerned about the potential administrative burden that this would place on assistance recipients. EPA recommends that projects with a high number of potentially covered products meet with their funding authority about potential compliance strategies to minimize burden and streamline compliance activity. Assistance recipients should prepare contract bid solicitation documents with a statement for the consulting engineers and construction firms as follows: “By signing payment application and recommending payment, Contractor certifies they have reviewed documentation for all products and materials submitted for payment, and the documentation is sufficient to demonstrate compliance with Build America,

Buy America Act requirements.” In most cases, the assistance recipient’s representatives may assume the responsibility for their clients to conduct due diligence on compliance with applicable domestic preference requirements.

- Q5.7: Who is responsible for documenting the 55 percent content requirement for manufactured products under BABA? What if the final manufacturer cannot trace or verify domestic origin for all components?
 - A5.7: The manufacturer who signs a certification letter is responsible for documenting compliance with any of the three categories of products (iron and steel, manufactured products, or construction materials). For manufactured products, BABA requires that greater than 55 percent of the total cost of all components of the manufactured product be from domestic sources. EPA recommends that the certification letter for manufactured products document whether the item passes the content test in the final product along with a statement attesting to compliance with the BABA requirements for manufactured products.
- Q5.8: How do final product fabricators document compliance when the final step of manufacturing may be simply assembling components?
 - A5.8: It is acceptable, in many cases, especially for highly complex manufactured products that utilize many sub-components, for the final point of assembly to certify without using a “step certification” process. Multiple certifications (i.e., step certifications) or a singular certification can be used for a product, as long as the certifying official is willing to attest to the product’s compliance with BABA requirements at all stages of manufacturing.
- Q5.9: Will Material Test Reports be acceptable in lieu of a BABA certification for iron and steel?
 - A5.9: Material Test Reports (MTRs, commonly referred to as “Mill Certifications” or “Mill Certs”) provide the chemical composition of steel and iron from a mill or foundry. If an MTR accompanies the delivery of steel or iron to a project site with an invoice or bill of lading, EPA will consider it sufficient to demonstrate compliance (equivalent to a certification letter) as long as the MTR includes a manufacturer representative’s signature in addition to the location (city and state) of the mill/foundry. It is common for MTRs to be the first letter in a “step certification” if the product is further fabricated or painted, etc., by another manufacturer.
- Q5.10: Can a manufacturer use a fillable certification letter for products?
 - A5.10: EPA recommends that certifications be signed by representatives of the manufacturing entity. EPA does not oppose manufacturers using forms to internally develop letters within their company, thereby providing signed, non-manipulable certification letters to suppliers, distributors, and/or assistance recipients. A fillable form that can be changed by someone outside of the manufacturer after signature does not demonstrate compliance and may create compliance concerns for the manufacturer or assistance recipient.

- Q5.11: Are product certifications from suppliers and distributors allowed?
 - A5.11: EPA recommends that representatives of product manufacturers certify compliance and discourages suppliers and distributors from creating certification letters. EPA does not rule out the possibility that a third-party certification process, such as a certification by a distributor, may be viable. However, EPA is currently not aware of a system or proposed system that meets the EPA’s recommendations for documentation of product certification.
- Q5.12: How long should assistance recipients keep compliance documentation?
 - A5.12: Assistance recipients should apply recordkeeping requirements for the project according to the procedures dictated by the funding authority. For most EPA grant programs, this is prescribed in the UGG at 2 CFR 200.334-200.338; e.g., the SRF programs require a minimum of three years. Other funding programs may require longer documentation retention periods.

SECTION 6: PROGRAMS WITH AMERICAN IRON AND STEEL REQUIREMENTS

- Q6.1: Does BABA supersede the American Iron and Steel (AIS) Requirements?
 - A6.1: The BABA requirements for items considered “iron and steel” are equivalent to those for covered iron and steel products under the AIS requirements in the Clean Water Act and the Safe Drinking Water Act. These requirements apply to the CWSRF, DWSRF, WIFIA, and Water infrastructure Community Grants. BABA includes a “Savings Provision” (Section 70917(b)) that states that BABA does not affect existing domestic content procurement preferences for infrastructure projects funded by Federal financial assistance programs that meet the requirements of section 70914. EPA views the AIS requirements as meeting the “iron and steel” product requirements of BABA Section 70914, as they both include the key requirement that items made of iron and steel be wholly manufactured in the United States from the point of melting and/or pouring the iron or steel components through final manufacturing step. Because of the “Savings Provision” of Section 70917, the AIS requirements satisfy the “iron and steel” requirements of BABA. For the programs that have AIS requirements, EPA intends to implement BABA requirements the same way for iron and steel items as it has done for AIS products.
- Q6.2: For iron and steel products, does a manufacturer need to demonstrate compliance from initial melting through the finished product?
 - A6.2: For iron and steel products, the BABA requirements are the same as the existing AIS requirements, in that all of the iron and steel in a covered product (that is, the product is comprised of more than 50 percent iron and steel by material cost) must be melted and poured in the United States and all subsequent manufacturing processes (such as grinding, rolling, bending, reheating, and casting) must occur in the United States.

Q6.3: Will EPA apply the same manufacturing standards for BABA iron and steel products as for the American Iron and Steel (AIS) requirements?

- A6.3: Yes. For AIS, EPA did not require raw materials used in the production of steel or iron to be domestically sourced. For BABA, EPA interprets the requirements to be the same. Hence, like AIS, raw materials in the production of iron and steel subject to BABA requirements would not need to be domestically sourced. The key step for both AIS and BABA domestic iron and/or steel production is the melting/pouring (that is, the location of the furnace), which must be in the United States.

- Q6.4: Will the certification process be similar to the process established for the American Iron and Steel requirements?

- A6.4: EPA expects the certification process for the BABA requirements to be very similar to that established for the AIS requirements. For iron and steel products, the process should remain the same for AIS and BABA. EPA recommends for manufactured products and for construction materials that certification letters include direct reference to the product/material content requirements under BABA, in addition to an affirmative statement verifying that the product meets the BABA requirements.

- Q6.5: Will duplicate certification letters be required for AIS and BABA for iron/steel products?

- A6.5: No. Compliance with BABA requirements will be sufficient to demonstrate compliance with AIS requirements for iron and steel products. If a project is subject to BABA, the only demonstration of compliance necessary is with the BABA requirements, of which the iron and steel requirements are equivalent to those of the AIS statutory requirements: the iron or steel in a product made primarily or predominantly of iron and steel (comprising more than 50 percent iron and steel by material cost) must be melted and/or poured in the United States and all subsequent manufacturing processes must occur in the United States.

SECTION 7: PROGRAM-SPECIFIC ISSUES

- Q7.1.: How do the BABA requirements apply to Community Grants?

- A7.1: The Community Project Funding/Congressionally Directed Spending grants for the construction of drinking water, wastewater, and stormwater infrastructure and for water quality protection are subject to the requirements specified in the explanatory statement accompanying the Consolidated Appropriations Act (Explanatory Statement for Division G of P.L. 117-13, the Consolidated Appropriations Act of 2022). The explanatory statement asserts: “Applicable Federal requirements that would apply to a Clean Water State Revolving Fund or Drinking Water State Revolving Fund project grant recipient shall apply to a grantee receiving a CPF grant under this section.” Therefore, the federally funded Community Project Funding/Congressionally Directed Spending grants are subject to the same requirements that apply to CWSRF or DWSRF projects, including BABA and AIS requirements. See also A1.2.

- Q7.2: Should SRF projects covered by the BABA SRF Projects Design Planning Adjustment Period Waiver follow the same procedures for demonstrating compliance as outlined for American Iron and Steel requirements?
 - A7.2: Yes. The SRF Design Planning Adjustment Period waiver does not waive the iron and steel requirements under BABA. The SRF programs have existing domestic preference requirements for SRF projects under CWA Section 608 and SDWA Section 1452(a)(4) (AIS requirements) to use iron and steel products that are produced in the United States. Sections 70917(a) and (b) of BIL explain the application of BABA to existing domestic preference requirements. Specifically, the savings provision in Section 70917(b) states that existing domestic preference requirements that meet BABA requirements are not affected by BABA. The statutory AIS requirements were existing at the time BABA became law and satisfy the BABA iron and steel requirements. Therefore, the statutory AIS requirements that have previously applied to SRF-funded projects will continue to do so, and compliance with AIS requirements will satisfy the BABA iron and steel requirements. Demonstration of compliance for iron and steel products will follow the AIS implementation policies for projects subject to the waiver.

- Q7.3: For SRF programs, is BABA considered a federal cross-cutting authority? (i.e., do “equivalency” rules apply?)
 - A7.3: Yes, BABA is considered a federal cross-cutting requirement that applies to SRF assistance equivalent to the federal capitalization grant (i.e., “equivalency” projects). EPA’s SRF regulations at 40 CFR 35.3145 and 35.3575 require states and recipients of SRF funds equivalent to the amount of the federal capitalization grant to comply with federal cross-cutting requirements. Section 70914 of the IIJA, which states when a Buy America preference applies, explains that “none of the funds made available for a Federal financial assistance program for infrastructure...may be obligated for a project unless all of the iron, steel, manufactured products, and construction materials used in the project are produced in the United States.” Therefore, BABA only applies to projects funded in an amount equivalent to the federal capitalization grant and not to those projects receiving funds in excess of the capitalization grant (i.e., “non-equivalency” projects). (Note: The AIS requirements continue to apply for all SRF projects, including non-equivalency projects, and all WIFIA and Community Grant projects, because equivalency does not apply.)

- Q7.4: Do the BABA requirements apply to Drinking Water State Revolving Fund set-asides?
 - A7.4: Due to requirements related to the deposit of funds in the DWSRF program, almost all of the funds used to conduct set-aside activities are Federal dollars. Therefore, Federal cross-cutting requirements must be applied to all set-aside activities. However, in the case of most set-aside activities, the cross-cutting requirements will not be implicated because of the nature of the activities conducted under the set-asides. Because the BABA requirements only apply to infrastructure, and infrastructure typically is not an eligible set-aside expenditure (with one potential exception being loans for incentive-based source water protection

measures under the Local Assistance and Other State Programs Set-Aside), the BABA requirements will not apply to most set-aside activities.

- Q7.5: What if an SRF project is refinanced using Federal financial assistance on or after May 14, 2022?
 - A7.5: If an SRF project began construction, financed from another funding source, prior to May 14, 2022, but is refinanced through an assistance agreement executed on or after that date, BABA requirements will apply to all construction that occurs on or after May 14, 2022, through completion of construction, unless a waiver applies. There is no retroactive application of the BABA requirements where a refinancing occurs for an SRF project that has completed construction prior to May 14, 2022. (Note: If SRF funding is used for the refinancing, the AIS requirements may still apply depending on the timing of construction.)
- Q7.6: What are the roles and responsibilities for SRF programs for BABA implementation?
 - A7.6: Implementation of the BABA requirements for the State Revolving Fund programs will continue the roles and responsibilities from the successful AIS implementation process.

As with AIS, it is both the assistance recipient's and the state's responsibility to ensure compliance with the BABA requirements. The state is the recipient of a federal capitalization grant and must comply with all grant conditions, including a condition requiring adherence to BABA requirements.

Consequently, states are strongly advised to conduct site visits of projects during construction and review documentation demonstrating the assistance recipient's proof of compliance. In EPA's experience, most states conduct periodic site visits and arrange timely meetings with funded projects. Observed best practices typically include a meeting early in the process (sometimes before bid and usually prior to commencing construction) and at least one project site visit during the construction process. Assistance recipients must maintain documentation of compliance with the BABA requirements, as explained in question 5.3. The documents must be kept by the assistance recipient and should be reviewed by the state during project reviews.

The state's role in the waiver process is to review any waiver requests submitted to the state to ensure that all necessary information has been provided by the assistance recipient prior to forwarding the request to EPA. If a state finds the request lacking, the state should work with the assistance recipient to help obtain complete information. Question 4.1 explains the information needed by EPA to expediently review a waiver request.

In order to implement the BABA requirements, EPA has developed an approach for effective and efficient implementation of the waiver process to allow projects to proceed in a timely manner. The framework described below will allow states, on behalf of the assistance recipients, to apply for waivers of the BABA requirements directly to EPA Headquarters. Only waiver requests received and/or endorsed from states will be considered. Pursuant to BABA, EPA has the responsibility to make findings as to the issuance of waivers to the BABA requirements.

Step-by-step SRF Waiver Process

The waiver process begins with the assistance recipient. To fulfill the BABA requirements, the assistance recipient must in good faith design the project (where applicable) and solicit bids for construction with American-made iron and steel, manufactured goods, and construction materials. It is essential that the assistance recipient include the BABA terms in any request for proposals or solicitations for bids, and in all contracts (see Appendix 2 for sample construction contract language). The assistance recipient may receive a waiver at any point before, during, or after the bid process, if one or more of three statutory conditions is demonstrated to EPA and approved.

To apply for a project-specific waiver, the assistance recipient should email the request in the form of a Word document (.doc) or editable PDF (.pdf) to the funding program. It is strongly recommended that each state identify a person or persons for BABA communications. The state designee(s) will review the application for the waiver and determine whether the necessary information has been included (Note: More information may be provided in the future regarding what information is required to be included in waiver requests). Once the waiver application is complete, the designee will forward the application to CWSRFwaiver@epa.gov or DWSRFwaiver@epa.gov.

Evaluation by EPA

After receiving an application for waiver of the BABA requirements and ensuring sufficient information was provided, EPA will publish the request on its website for 15 days and receive public comment. EPA will then determine whether the application properly and adequately documents and justifies the statutory basis cited for the waiver.

In the event that EPA finds that adequate documentation and justification has been submitted, the Administrator may grant a waiver to the assistance recipient. EPA will notify the state designee whether a waiver request has been approved or not approved as soon as such a decision has been made. Granting such a waiver is a four-step process:

1. Research – After receiving an application for a waiver, EPA will perform market research to determine whether the iron, steel, manufactured goods, or construction materials are available domestically.
2. Posting – After research, if no domestic product has been identified, EPA is required to publish the application and all material submitted with the application on EPA's website for 15 days. During that period, the public will have the opportunity to review the request and provide informal comment to EPA. The website can be found at: <https://www.epa.gov/cwsrf/build-america-buy-america-baba-waivers-open-public-comment>.
3. Evaluation – After receiving an application for waiver of the BABA requirements, EPA will determine whether the application properly and adequately documents and justifies the statutory basis cited for the waiver to determine whether or not to grant the waiver.

3. Signature of waiver approval by the Administrator or another agency official with delegated authority – As soon as the waiver is signed and dated, EPA will notify the State SRF program and post the signed waiver on the Agency’s website. The assistance recipient should keep a copy of the signed waiver in its project files.

(Note: Additional steps may be required in the future regarding the waiver process depending on additional guidance from OMB)

APPENDIX 1

Example Build America, Buy America (BABA) Act Construction Contract Language

ALL CONSTRUCTION CONTRACTS MUST HAVE A CLAUSE REQUIRING COMPLIANCE WITH THE BABA REQUIREMENTS. THIS IS AN EXAMPLE OF WHAT COULD BE INCLUDED IN A PROJECT'S CONSTRUCTION CONTRACT. EPA MAKES NO CLAIMS REGARDING THE LEGALITY OF THIS CLAUSE WITH RESPECT TO STATE OR LOCAL LAW:

The Contractor acknowledges to and for the benefit of the _____ (“Owner”) and the _____ (the “Funding Authority”) that it understands the goods and services under this Agreement are being funded with federal monies and have statutory requirements commonly known as “Build America, Buy America;” that requires all of the iron and steel, manufactured products, and construction materials used in the project to be produced in the United States (“Build America, Buy America Requirements”) including iron and steel, manufactured products, and construction materials provided by the Contractor pursuant to this Agreement. The Contractor hereby represents and warrants to and for the benefit of the Owner and Funding Authority (a) the Contractor has reviewed and understands the Build America, Buy America Requirements, (b) all of the iron and steel, manufactured products, and construction materials used in the project will be and/or have been produced in the United States in a manner that complies with the Build America, Buy America Requirements, unless a waiver of the requirements is approved, and (c) the Contractor will provide any further verified information, certification or assurance of compliance with this paragraph, or information necessary to support a waiver of the Build America, Buy America Requirements, as may be requested by the Owner or the Funding Authority. Notwithstanding any other provision of this Agreement, any failure to comply with this paragraph by the Contractor shall permit the Owner or Funding Authority to recover as damages against the Contractor any loss, expense, or cost (including without limitation attorney’s fees) incurred by the Owner or Funding Authority resulting from any such failure (including without limitation any impairment or loss of funding, whether in whole or in part, from the Funding Authority or any damages owed to the Funding Authority by the Owner). If the Contractor has no direct contractual privity with the Funding Authority, as a lender or awardee to the Owner for the funding of its project, the Owner and the Contractor agree that the Funding Authority is a third-party beneficiary and neither this paragraph (nor any other provision of this Agreement necessary to give this paragraph force or effect) shall be amended or waived without the prior written consent of the Funding Authority.

APPENDIX 2

Example Build America, Buy America (BABA) Act Assistance Agreement Language

ALL FEDERAL FINANCIAL INFRASTRUCTURE ASSISTANCE AGREEMENTS MUST HAVE A CLAUSE REQUIRING COMPLIANCE WITH THE BABA REQUIREMENTS. THIS IS AN EXAMPLE OF WHAT COULD BE INCLUDED IN AN ASSISTANCE AGREEMENT (E.G., SRF LOAN AGREEMENT). EPA MAKES NO CLAIMS REGARDING THE LEGAL SUFFICIENCY OF THIS CLAUSE WITH RESPECT TO STATE LAW:

Comply with all federal requirements applicable to the assistance received (including those imposed by the Infrastructure Investment and Jobs Act (“IIJA”), Public Law No. 117-58) which the Participant understands includes, but is not limited to, the following requirements: that all of the iron and steel, manufactured products, and construction materials used in the Project are to be produced in the United States (“Build America, Buy America Requirements”) unless (i) the Participant has requested and obtained a waiver from the cognizant Agency^[1] pertaining to the Project or the Project is otherwise covered by a general applicability waiver; or (ii) all of the contributing Agencies have otherwise advised the Participant in writing that the Build America, Buy America Requirements are not applicable to the Project.

Comply with all record keeping and reporting requirements under all applicable legal authorities, including any reports required by the funding authority (such as EPA and/or a state), such as performance indicators of program deliverables, information on costs and project progress. The Participant understands that (i) each contract and subcontract related to the Project is subject to audit by appropriate federal and state entities and (ii) failure to comply with the applicable legal requirements and this Agreement may result in a default hereunder that results in a repayment of the assistance agreement in advance of the maturity of the Bonds, termination and/or repayment of grants, cooperative agreements, direct assistance or other types of financial assistance, and/or other remedial actions.

^[1] From OMB Guidance M-22-11: To avoid a need for duplicative waiver requests from entities that receive funding for one infrastructure project through multiple Federal agencies, the Federal agency contributing the greatest amount of Federal funds for the project should be considered the “Cognizant Agency for Made in America” and should take responsibility for coordinating with the other Federal awarding agencies. Such coordination will provide uniform waiver criteria and adjudication processes, minimize duplicative efforts among Federal agencies, and reduce burdens on recipients. The Cognizant Agency for Made in America shall be responsible for consulting with the other Federal awarding agencies, publicizing the proposed joint waiver, and submitting the proposed joint waiver for review to MIAO.

Appendix T
Relevant Federal and State Laws Applicable
to The Drinking Water State Revolving Fund
Program



Rhode Island Department of Health Center for Drinking Water Quality

Drinking Water State Revolving Fund Program Relevant Federal and State Laws

A. Federal

- 1) Equal Employment Opportunity and Affirmative Action (Executive Order 11246)
 - i) OFCCP fact sheet.
 - ii) Equal Opportunity Clause and the Standard Federal Equal Employment Specifications.
 - iii) Notice of Non-Discrimination in Employment.
- 2) Non-discrimination in employment notice.
- 3) Assurance of compliance with Title VI of the Civil Rights Act of 1964 and Section 13 of the FWPCA Amendments of 1972 (EPA form 4700-1).
- 4) Affirmative steps for soliciting MBE/WBE (40 CFR 31.36(e))

Applicable cross-cutting Federal authorities for projects funded through SRF programs are made available at http://water.epa.gov/grants_funding/dwsrf/xcuts.cfm. Additional information is provided in the United States Environmental Protection Agency's cross-cutting handbook available at <https://www.epa.gov/sites/production/files/2015-08/documents/crosscutterhandbook.pdf>.

B. State of Rhode Island

- 1) RIGL 37-2.1, Domestic Steel
- 2) RIGL 37-12, Contractors Bonds
- 3) RIGL 37-12.1, Substitution of Security for Retained Earnings of Architects and Engineers.
- 4) RIGL 37-13, Labor and Payment of Debts by Contractors
 - i) Prevailing Wage Rates
- 5) RIGL 37-14.1, Minority Business Enterprise
 - i) Regulations Governing Participation by Minority Business Enterprises in State Funded and Directed Public Construction Projects, Construction Contracts and Procurement Contracts Goods and Services.
- 6) RIGL 37-16, Public Works Arbitration
- 7) RIGL 45-55, Award of Municipal Contracts

NOTE: This package is prepared by DOH as a service of the DWSRF program. While every attempt at accuracy has been made, these are not certified true copies of the laws presented. **The responsibility for compliance with all applicable provisions of Federal and State laws and regulations relating to the bidding, award, and performance of contracts is the applicant's and the bidder's.** Certified true and complete copies of any Rhode Island laws and regulations may be obtained from the Office of the Secretary of State.

Employment Standards Administration Office of Federal Contract Compliance Programs

Fact Sheet EXECUTIVE ORDER 11246

EEO and Affirmative Action Guidelines for Federal Contractors Regarding Race, Color, Gender, Religion, and National Origin.

BASIC PROVISIONS

Since 1965, the U.S. Department of Labor's Office of Federal Contract Compliance Programs (OFCCP) has been committed to ensuring that Government contractors comply with the equal employment opportunity (EEO) and the affirmative action provisions of their contracts.

OFCCP administers and enforces Executive Order 11246, as amended, which prohibits federal contractors and federally-assisted construction contractors and subcontractors, who do over \$10,000 in Government business in one year from discriminating in employment decisions on the basis of race, color, religion, sex, sexual orientation, gender identity, or national origin.

The Executive Order also requires Government contractors to take affirmative action to insure that equal opportunity is provided in all aspects of their employment.

AFFIRMATIVE ACTION REQUIREMENTS

Each Government contractor with 50 or more employees and \$50,000 or more in government contracts is required to develop a written affirmative action program (AAP) for each of its establishments.

A written affirmative action program helps the contractor identify and analyze potential problems in the participation and utilization of women and minorities in the contractor's workforce.

If there are problems, the contractor will specify in its AAP the specific procedures it will follow and the good faith efforts it will make to provide equal employment opportunity.

Expanded efforts in outreach, recruitment, training and other areas are some of the affirmative steps contractors can take to help members of the protected groups compete for jobs on equal footing with other applicants and employees.

Affirmative action is not preferential treatment. It does not mean that unqualified persons should be hired or promoted over other people. What affirmative action does mean is that positive steps must be taken to ensure equal employment opportunity for traditionally disadvantaged groups.

ENFORCEMENT AND COMPLIANCE

Compliance Reviews

OFCCP conducts compliance reviews to investigate the employment practices of Government contractors. During a compliance review, a compliance officer examines the contractor's affirmative action program; checks personnel, payroll, and other employment records; interviews employees and company officials; and investigates virtually all aspects of employment in the company.

The investigator also checks to see whether the contractor is making special efforts to achieve equal opportunity through affirmative action. If problems are discovered, OFCCP will recommend corrective action and suggest ways to achieve equal employment opportunity.

Complaint Investigations

Individuals may file complaints if they believe they have been discriminated against by federal contractors or subcontractors. Complaints also may be filed by organizations on behalf of the person or persons affected.

Complaints must be filed within 180 days from the date of the alleged discrimination, although filing time can be extended for a good reason.

If a complaint filed under Executive Order 11246 involves discrimination against only one person, OFCCP will normally refer it to the EEOC. Cases involving groups of people or indicating patterns of discrimination are generally investigated and resolved by OFCCP. Complaints may be filed directly with any of OFCCP's regional or district offices throughout the country, or with OFCCP in Washington, D.C.

Compliance Assistance

To help contractors understand their contractual obligations for EEO and affirmative action, OFCCP provides technical assistance. District office staff offers guidance to contractors on how to develop an affirmative program through company seminars, training programs held in conjunction with industry liaison groups, and one-on-one consultations on affirmative action practices and procedures.

Enforcing Contract Compliance

When a compliance review discloses problems, OFCCP attempts to work with the contractor, often entering into a conciliation agreement. A conciliation agreement may include back pay, job offers, seniority credit, promotions or other forms of relief for victims of discrimination. It may also involve new training programs, special recruitment efforts, or other affirmative action measures.

When conciliation efforts are unsuccessful, OFCCP refers the case to the Office of the Solicitor for enforcement through administrative enforcement proceedings. A contractor cited for violating EEO and affirmative action requirements may have a formal hearing before an administrative law judge.

If conciliation is not reached before or after the hearing, sanctions may be imposed. For example, a contractor could lose its government contracts or subcontracts or be debarred, i.e., declared ineligible for any future government contracts.

Further Information

For more information about contract compliance, filing complaints, or compliance assistance, contact any of OFCCP's regional or district offices. All offices are listed in telephone directories under U.S. Department of Labor, Employment Standards Administration, Office of Federal Contract Compliance Programs.

EQUAL EMPLOYMENT OPPORTUNITY AND AFFIRMATIVE ACTION

Executive Order 11246

(Excerpts from 41 CFR 60 Parts 1 and 4)

41 CFR 60-1.4 - Equal opportunity clause

(b) Federally assisted construction contracts. Except as otherwise provided, each administering agency shall require the inclusion of the following language as a condition of any grant, contract, loan, insurance, or guarantee involving federally assisted construction which is not exempt from the requirements of the equal opportunity clause:

The applicant hereby agrees that it will incorporate or cause to be incorporated into any contract for construction work, or modification thereof, as defined in the regulations of the Secretary of Labor at 41 CFR Chapter 60, which is paid for in whole or in part with funds obtained from the Federal Government or borrowed on the credit of the Federal Government pursuant to a grant, contract, loan insurance, or guarantee, or undertaken pursuant to any Federal program involving such grant, contract, loan, insurance, or guarantee, the following *equal opportunity clause*:

During the performance of this contract, the contractor agrees as follows:

- (1) The contractor will not discriminate against any employee or applicant for employment because of race, color, religion, sex, sexual orientation, gender identity, or national origin. The contractor will take affirmative action to ensure that applicants are employed, and that employees are treated during employment without regard to their race, color, religion, sex, or national origin. Such action shall include, but not be limited to the following: Employment, upgrading, demotion, or transfer; recruitment or recruitment advertising; layoff or termination; rates of pay or other forms of compensation; and selection for training, including apprenticeship. The contractor agrees to post in conspicuous places, available to employees and applicants for employment, notices to be provided setting forth the provisions of this nondiscrimination clause. Such action shall include but not be limited to the following:
- (2) Employment, upgrading, demotion, or transfer; recruitment or recruitment advertising; layoff or termination; rates of pay or other forms of compensation; and selection for training, including apprenticeship. The contractor agrees to post in conspicuous places, available to employees and applicants for employment, notices to be provided setting forth the provisions of this nondiscrimination clause. The contractor will, in all solicitations or advertisements for employees placed by or on behalf of the contractor, state that all qualified applicants will receive considerations for employment without regard to race, color, religion, sex, sexual orientation, gender identity, or national origin.
- (3) The contractor will not discharge or in any other manner discriminate against any employee or applicant for employment because such employee or applicant has inquired about, discussed, or disclosed the compensation of the employee or applicant or another employee or applicant. This provision shall not apply to instances in which an employee who has access to the compensation information of other employees or applicants as a part of such employee's essential job functions discloses the compensation of such other employees or applicants to individuals who do not otherwise have access to such information, unless such disclosure is in response to a formal complaint or charge, in furtherance of an investigation, proceeding, hearing, or action, including an investigation conducted by the employer, or is consistent with the contractor's legal duty to furnish information.
- (4) The contractor will send to each labor union or representative of workers with which he has a collective bargaining agreement or other contract or understanding, a notice to be provided advising the said labor union or workers' representatives of the contractor's commitments under this section, and shall post copies of the notice in conspicuous places available to employees and applicants for employment.
- (5) The contractor will comply with all provisions of Executive Order 11246 of September 24, 1965, and of the rules, regulations, and relevant orders of the Secretary of Labor.
- (6) The contractor will furnish all information and reports required by Executive Order 11246 of September 24, 1965, and by rules, regulations, and orders of the Secretary of Labor, or pursuant thereto, and will

permit access to his books, records, and accounts by the administering agency and the Secretary of Labor for purposes of investigation to ascertain compliance with such rules, regulations, and orders.

- (7) In the event of the contractor's noncompliance with the nondiscrimination clauses of this contract or with any of the said rules, regulations, or orders, this contract may be canceled, terminated, or suspended in whole or in part and the contractor may be declared ineligible for further Government contracts or federally assisted construction contracts in accordance with procedures authorized in Executive Order 11246 of September 24, 1965, and such other sanctions may be imposed and remedies invoked as provided in Executive Order 11246 of September 24, 1965, or by rule, regulation, or order of the Secretary of Labor, or as otherwise provided by law.
- (8) The contractor will include the portion of the sentence immediately preceding paragraph (1) and the provisions of paragraphs (1) through (8) in every subcontract or purchase order unless exempted by rules, regulations, or orders of the Secretary of Labor issued pursuant to section 204 of Executive Order 11246 of September 24, 1965, so that such provisions will be binding upon each subcontractor or vendor. The contractor will take such action with respect to any subcontract or purchase order as the administering agency may direct as a means of enforcing such provisions, including sanctions for noncompliance:

Provided, however, that in the event a contractor becomes involved in, or is threatened with, litigation with a subcontractor or vendor as a result of such direction by the administering agency the contractor may request the United States to enter into such litigation to protect the interests of the United States.

The applicant further agrees that it will be bound by the above equal opportunity clause with respect to its own employment practices when it participates in federally assisted construction work: Provided, that if the applicant so participating is a State or local government, the above equal opportunity clause is not applicable to any agency, instrumentality or subdivision of such government which does not participate in work on or under the contract.

The applicant agrees that it will assist and cooperate actively with the administering agency and the Secretary of Labor in obtaining the compliance of contractors and subcontractors with the equal opportunity clause and the rules, regulations, and relevant orders of the Secretary of Labor, that it will furnish the administering agency and the Secretary of Labor such information as they may require for the supervision of such compliance, and that it will otherwise assist the administering agency in the discharge of the agency's primary responsibility for securing compliance.

The applicant further agrees that it will refrain from entering into any contract or contract modification subject to Executive Order 11246 of September 24, 1965, with a contractor debarred from, or who has not demonstrated eligibility for, Government contracts and federally assisted construction contracts pursuant to the Executive order and will carry out such sanctions and penalties for violation of the equal opportunity clause as may be imposed upon contractors and subcontractors by the administering agency or the Secretary of Labor pursuant to Part II, Subpart D of the Executive order. In addition, the applicant agrees that if it fails or refuses to comply with these undertakings, the administering agency may take any or all of the following actions: Cancel, terminate, or suspend in whole or in part this grant (contract, loan, insurance, guarantee); refrain from extending any further assistance to the applicant under the program with respect to which the failure or refund occurred until satisfactory assurance of future compliance has been received from such applicant; and refer the case to the Department of Justice for appropriate legal proceedings.

(c) *Subcontracts.* Each nonexempt prime contractor or subcontractor shall include the equal opportunity clause in each of its nonexempt subcontracts.

(d) *Incorporation of the equal opportunity clause by reference.* The equal opportunity clause may be incorporated by reference in all Government contracts and subcontracts, including Government bills of lading, transportation requests, contracts for deposit of Government funds, and contracts for issuing and paying U.S. savings bonds and notes, and such other contracts and subcontracts as the Director may designate.

(e) *Incorporation by operation of the order.* By operation of the order, the equal opportunity clause shall be considered to be a part of every contract and subcontract required by the order and the regulations in this part to include such a clause whether or not it is physically incorporated in such contracts and whether or not the contract between the agency and the contractor is written.

(f) Adaptation of language. Such necessary changes in language may be made in the equal opportunity clause as shall be appropriate to identify properly the parties and their undertakings.

41 CFR 60-4.3 - Equal opportunity clauses

(a) The equal opportunity clause published at 41 CFR 60-1.4(a) of this chapter is required to be included in, and is part of, all nonexempt Federal contracts and subcontracts, including construction contracts and subcontracts. The equal opportunity clause published at 41 CFR 60-1.4(b) is required to be included in, and is a part of, all nonexempt federally assisted construction contracts and subcontracts. In addition to the clauses described above, all Federal contracting officers, all applicants and all non-construction contractors, as applicable, shall include the specifications set forth in this section in all Federal and federally assisted construction contracts in excess of \$10,000 to be performed in geographical areas designated by the Director pursuant to 60-4.6 of this part and in construction subcontracts in excess of \$10,000 necessary in whole or in part to the performance of non-construction Federal contracts and subcontracts covered under the Executive order.

Standard Federal Equal Employment Opportunity Construction Contract Specifications (Executive Order 11246)

1. As used in these specifications:
 - a. "Covered area" means the geographical area described in the solicitation from which this contract resulted;
 - b. "Director" means Director, Office of Federal Contract Compliance Programs, United States Department of Labor, or any person to whom the Director delegates authority;
 - c. "Employer identification number" means the Federal Social Security number used on the Employer's Quarterly Federal Tax Return, U.S. Treasury Department Form 941.
 - d. "Minority" includes:
 - (i) Black (all persons having origins in any of the Black African racial groups not of Hispanic origin);
 - (ii) Hispanic (all persons of Mexican, Puerto Rican, Cuban, Central or South American or other Spanish Culture or origin, regardless of race);
 - (iii) Asian and Pacific Islander (all persons having origins in any of the original peoples of the Far East, Southeast Asia, the Indian Subcontinent, or the Pacific Islands); and
 - (iv) American Indian or Alaskan Native (all persons having origins in any of the original peoples of North America and maintaining identifiable tribal affiliations through membership and participation or community identification).
2. Whenever the Contractor, or any Subcontractor at any tier, subcontracts a portion of the work involving any construction trade, it shall physically include in each subcontract in excess of \$10,000 the provisions of these specifications and the Notice which contains the applicable goals for minority and female participation and which is set forth in the solicitations from which this contract resulted.
3. If the Contractor is participating (pursuant to 41 CFR 60-4.5) in a Hometown Plan approved by the U.S. Department of Labor in the covered area either individually or through an association, its affirmative action obligations on all work in the Plan area (including goals and timetables) shall be in accordance with that Plan for those trades which have unions participating in the Plan. Contractors must be able to demonstrate their participation in and compliance with the provisions of any such Hometown Plan. Each Contractor or Subcontractor participating in an approved Plan is individually required to comply with its obligations under the EEO clause, and to make a good faith effort to achieve each goal under the Plan in each trade in which it has employees. The overall good faith performance by other Contractors or Subcontractors toward a goal in an approved Plan does not excuse any covered Contractor's or Subcontractor's failure to take good faith efforts to achieve the Plan goals and timetables.
4. The Contractor shall implement the specific affirmative action standards provided in paragraphs 7 a through p of these specifications. The goals set forth in the solicitation from which this contract resulted are expressed as percentages of the total hours of employment and training of minority and female utilization the Contractor should reasonably be able to achieve in each construction trade in which it has employees in the covered area. Covered Construction contractors performing construction work in geographical areas where they do not have a Federal or federally assisted construction contract shall apply the minority and female goals established for the geographical area where the work is being performed. Goals are published periodically in the Federal Register in notice form, and such notices may be obtained from any Office of Federal Contract Compliance Programs office or from Federal procurement contracting officers. The Contractor is expected to make substantially uniform progress in meeting its goals in each craft during the period specified.

5. Neither the provisions of any collective bargaining agreement, nor the failure by a union with whom the Contractor has a collective bargaining agreement, to refer either minorities or women shall excuse the Contractor's obligations under these specifications, Executive Order 11246, or the regulations promulgated pursuant thereto.
6. In order for the non-working training hours of apprentices and trainees to be counted in meeting the goals, such apprentices and trainees must be employed by the Contractor during the training period, and the Contractor must have made a commitment to employ the apprentices and trainees at the completion of their training, subject to the availability of employment opportunities. Trainees must be trained pursuant to training programs approved by the U.S. Department of Labor.
7. The Contractor shall take specific affirmative actions to ensure equal employment opportunity. The evaluation of the Contractor's compliance with these specifications shall be based upon its effort to achieve maximum results from its actions. The Contractor shall document these efforts fully, and shall implement affirmative action steps at least as extensive as the following:
 - a. Ensure and maintain a working environment free of harassment, intimidation, and coercion at all sites, and in all facilities at which the Contractor's employees are assigned to work. The Contractor, where possible, will assign two or more women to each construction project. The Contractor shall specifically ensure that all foremen, superintendents, and other on-site supervisory personnel are aware of and carry out the Contractor's obligation to maintain such a working environment, with specific attention to minority or female individuals working at such sites or in such facilities.
 - b. Establish and maintain a current list of minority and female recruitment sources, provide written notification to minority and female recruitment sources and to community organizations when the Contractor or its unions have employment opportunities available, and maintain a record of the organizations' responses.
 - c. Maintain a current file of the names, addresses and telephone numbers of each minority and female off-the-street applicant and minority or female referral from a union, a recruitment source or community organization and of what action was taken with respect to each such individual. If such individual was sent to the union hiring hall for referral and was not referred back to the Contractor by the union or, if referred, not employed by the Contractor, this shall be documented in the file with the reason therefor, along with whatever additional actions the Contractor may have taken.
 - d. Provide immediate written notification to the Director when the union or unions with which the Contractor has a collective bargaining agreement has not referred to the Contractor a minority person or woman sent by the Contractor, or when the Contractor has other information that the union referral process has impeded the Contractor's efforts to meet its obligations.
 - e. Develop on-the-job training opportunities and/or participate in training programs for the area which expressly include minorities and women, including upgrading programs and apprenticeship and trainee programs relevant to the Contractor's employment needs, especially those programs funded or approved by the Department of Labor. The Contractor shall provide notice of these programs to the sources compiled under 7b above.
 - f. Disseminate the Contractor's EEO policy by providing notice of the policy to unions and training programs and requesting their cooperation in assisting the Contractor in meeting its EEO obligations; by including it in any policy manual and collective bargaining agreement; by publicizing it in the company newspaper, annual report, etc.; by specific review of the policy with all management personnel and with all minority and female employees at least once a year; and by posting the company EEO policy on bulletin boards accessible to all employees at each location where construction work is performed.
 - g. Review, at least annually, the company's EEO policy and affirmative action obligations under these specifications with all employees having any responsibility for hiring, assignment, layoff, termination or other employment decisions including specific review of these items with onsite supervisory personnel such as Superintendents, General Foremen, etc., prior to the initiation of construction work at any job site. A written record shall be made and maintained identifying the time and place of these meetings, persons attending, subject matter discussed, and disposition of the subject matter.
 - h. Disseminate the Contractor's EEO policy externally by including it in any advertising in the news media, specifically including minority and female news media, and providing written notification to and discussing the Contractor's EEO policy with other Contractors and Subcontractors with whom the Contractor does or anticipates doing business.
 - i. Direct its recruitment efforts, both oral and written, to minority, female and community organizations, to schools with minority and female students and to minority and female recruitment and training organizations

- serving the Contractor's recruitment area and employment needs. Not later than one month prior to the date for the acceptance of applications for apprenticeship or other training by any recruitment source, the Contractor shall send written notification to organizations such as the above, describing the openings, screening procedures, and tests to be used in the selection process.
- j. Encourage present minority and female employees to recruit other minority persons and women and, where reasonable, provide after school, summer and vacation employment to minority and female youth both on the site and in other areas of a Contractor's work force.
 - k. Validate all tests and other selection requirements where there is an obligation to do so under 41 CFR Part 60-3.
 - l. Conduct, at least annually, an inventory and evaluation at least of all minority and female personnel for promotional opportunities and encourage these employees to seek or to prepare for, through appropriate training, etc., such opportunities.
 - m. Ensure that seniority practices, job classifications, work assignments and other personnel practices, do not have a discriminatory effect by continually monitoring all personnel and employment related activities to ensure that the EEO policy and the Contractor's obligations under these specifications are being carried out.
 - n. Ensure that all facilities and company activities are non-segregated except that separate or single-user toilet and necessary changing facilities shall be provided to assure privacy between the sexes.
 - o. Document and maintain a record of all solicitations of offers for subcontracts from minority and female construction contractors and suppliers, including circulation of solicitations to minority and female contractor associations and other business associations.
 - p. Conduct a review, at least annually, of all supervisors' adherence to and performance under the Contractor's EEO policies and affirmative action obligations.
8. Contractors are encouraged to participate in voluntary associations which assist in fulfilling one or more of their affirmative action obligations (7a through p). The efforts of a contractor association, joint contractor-union, contractor-community, or other similar group of which the contractor is a member and participant, may be asserted as fulfilling any one or more of its obligations under 7a through p of these Specifications provided that the contractor actively participates in the group, makes every effort to assure that the group has a positive impact on the employment of minorities and women in the industry, ensures that the concrete benefits of the program are reflected in the Contractor's minority and female workforce participation, makes a good faith effort to meet its individual goals and timetables, and can provide access to documentation which demonstrates the effectiveness of actions taken on behalf of the Contractor. The obligation to comply, however, is the Contractor's and failure of such a group to fulfill an obligation shall not be a defense for the Contractor's noncompliance
9. A single goal for minorities and a separate single goal for women have been established. The Contractor, however, is required to provide equal employment opportunity and to take affirmative action for all minority groups, both male and female, and all women, both minority and non-minority. Consequently, the Contractor may be in violation of the Executive Order if a particular group is employed in a substantially disparate manner (for example, even though the Contractor has achieved its goals for women generally, the Contractor may be in violation of the Executive Order if a specific minority group of women is underutilized).
10. The Contractor shall not use the goals and timetables or affirmative action standards to discriminate against any person because of race, color, religion, sex, or national origin.
11. The Contractor shall not enter into any Subcontract with any person or firm debarred from Government contracts pursuant to Executive Order 11246.
12. The Contractor shall carry out such sanctions and penalties for violation of these specifications and of the Equal Opportunity Clause, including suspension, termination and cancellation of existing subcontracts as may be imposed or ordered pursuant to Executive Order 11246, as amended, and its implementing regulations, by the Office of Federal Contract Compliance Programs. Any Contractor who fails to carry out such sanctions and penalties shall be in violation of these specifications and Executive Order 11246, as amended.
13. The Contractor, in fulfilling its obligations under these specifications, shall implement specific affirmative action steps, at least as extensive as those standards prescribed in paragraph 7 of these specifications, so as to achieve maximum results from its efforts to ensure equal employment opportunity. If the Contractor fails to

comply with the requirements of the Executive Order, the implementing regulations, or these specifications, the Director shall proceed in accordance with 41 CFR 60-4.8.

14. The Contractor shall designate a responsible official to monitor all employment related activity to ensure that the company EEO policy is being carried out, to submit reports relating to the provisions hereof as may be required by the Government and to keep records. Records shall at least include for each employee the name, address, telephone numbers, construction trade, union affiliation if any, employee identification number when assigned, social security number, race, sex, status (e.g., mechanic, apprentice trainee, helper, or laborer), dates of changes in status, hours worked per week in the indicated trade, rate of pay, and locations at which the work was performed. Records shall be maintained in an easily understandable and retrievable form; however, to the degree that existing records satisfy this requirement, contractors shall not be required to maintain separate records.

15. Nothing herein provided shall be construed as a limitation upon the application of other laws which establish different standards of compliance or upon the application of requirements for the hiring of local or other area residents (e.g., those under the Public Works Employment Act of 1977 and the Community Development Block Grant Program).

(b) The notice set forth in 41 CFR 60-4.2 and the specifications set forth in 41 CFR 60-4.3 replace the New Form for Federal Equal Employment Opportunity Bid Conditions for Federal and Federally Assisted Construction published at 41 FR 32482 and commonly known as the Model Federal EEO Bid Conditions, and the New Form shall not be used after the regulations in 41 CFR Part 60-4 become effective.

[43 FR 49254, Oct. 20, 1978; 43 FR 51401, Nov. 3, 1978, as amended at 45 FR 65978, Oct. 3, 1980]

NOTICE TO LABOR UNIONS OR OTHER ORGANIZATIONS OF WORKERS

NON-DISCRIMINATION IN EMPLOYMENT

TO: _____
(Name of Union or Organization of Workers)

The undersigned currently holds contract(s) with _____
(Name of Applicant)

involving funds or credit of the U.S. Government of (a) subcontract(s) with a prime contractor holding such contract(s).

You are advised that under the provisions of the above contract(s) or subcontract(s) and in accordance with Executive Order 11246, dated September 24, 1965, the undersigned is obliged not to discriminate against any employee or applicant for employment because of race, age, handicap, veteran status, color, creed, or national origin. This obligation not to discriminate in employment includes, but is not limited to, the following:

**HIRING, PLACEMENT, UPGRADING, TRANSFER, OR DEMOTION,
RECRUITMENT, ADVERTISING, OR SOLICITATION FOR
EMPLOYMENT TRAINING DURING EMPLOYMENT, RATES OF PAY
OR OTHER FORMS OF COMPENSATION, SELECTION FOR TRAINING
INCLUDING APPRENTICESHIP, LAYOFF, OR TERMINATION.**

This notice is furnished you pursuant to the provisions of the above contract(s) or subcontract(s) and Executive Order 11246.

COPIES OF THIS NOTICE WILL BE POSTED BY THE UNDERSIGNED IN CONSPICUOUS PLACES AVAILABLE TO EMPLOYEES OR APPLICANTS FOR EMPLOYMENT.

(Contractor or Subcontractor)

(Date)

CONTRACTING WITH SMALL AND MINORITY FIRMS, WOMEN'S BUSINESS ENTERPRISE

40 CFR 31.36(e)

40 CFR 31.36(e) – Contracting with small and minority firms, women's business enterprise and labor surplus area firms.

(1) The grantee and sub-grantee will take all necessary affirmative steps to assure that minority firms, women's business enterprises, and labor surplus area firms are used when possible.

(2) Affirmative steps shall include:

- (i) Placing qualified small and minority businesses and women's business enterprises on solicitation lists;
- (ii) Assuring that small and minority businesses and women's business enterprises are solicited whenever they are potential sources;
- (iii) Dividing the total requirements, when economically feasible, into smaller tasks or quantities to permit maximum participation by small and minority businesses, and women's business enterprises;
- (iv) Establishing delivery schedules, where the requirement permits, which encourage participation by small and minority businesses, and women's business enterprises;
- (v) Using the services and assistance of the Small Business Administration, and the Minority Business Development Agency of the Department of Commerce; and
- (vi) Requiring the prime contractor, if subcontracts are to be let, to take affirmative steps listed in paragraphs (e)(2)(i) through (v) of this section.

TITLE 37

CHAPTER 2.1 DOMESTIC STEEL

Section

37-2.1-1.	Short Title
37-2.1-2.	Purpose
37-2.1-3.	Purchase of steel and steel products
37-2.1-4.	Payment
37-2.1-5.	Definitions

37-2.1-1. Short title.

This chapter shall be known and may be cited as the "Steel Products Procurement Act".

37-2.1-2. Purpose.

- (a) This chapter shall be deemed to be an exercise of the police powers of the state for the protection of the health, safety, and general welfare of the people of the state.
- (b) It is hereby determined by the general assembly of Rhode Island and declared as a matter of legislative findings that:
 - (1) The United States is one of the leading countries in the production and use of steel and its allied products;
 - (2) The use of steel products constitutes a major industry of the United States and, as such, provides the jobs and family incomes of millions of persons in the United States;
 - (3) The taxes paid to Rhode Island and the United States by employers and employees engaged in the production and sale of steel products are one of the largest single sources of public revenues in this country;
 - (4) It has, for many years, been the policy of the state to aid and support the development and expansion of industry in the United States in order to foster the economic well-being of the state and its people; and
 - (5) The economy, general welfare, and national security of the United States, are inseparably related to the preservation and development of the steel industry in the United States.
- (c) The general assembly therefore declares it to be the policy of the state that all public officers and agencies should, at all times, aid and promote the development of the steel industry of the United States in order to stimulate and improve the economic well-being of the state and its people.

37-2.1-3. Purchase of steel and steel products.

- (a) Every public agency shall require that every contract document for the construction, reconstruction, alteration, repair, improvement, or maintenance of public works contain a provision that, if any steel products are to be used or supplied in the performance of the contract, only steel products as herein defined shall be used or supplied in the performance of the contract or any subcontracts thereunder.
- (b) This section shall not apply in any case where the head of the public agency, in writing, determines that steel products as herein defined are not produced in, or readily available in the United States or that such steel products shall not exceed fifteen percent (15%) of the costs of any other steel products obtainable nationally or internationally.

37-2.1-4. Payment.

No public agency shall authorize, provide for, or make any payments to any person under any contract containing the provision required by 37-2.1-3 unless the public agency is satisfied that such person has fully complied with that provision. Any such payments made to any person by any public agency which should not have been made, as a result of this section, shall be recoverable directly from the contractor or subcontractor who did not comply with 37-2.1-3 by either such public agency or the attorney general upon suit filed in the court of any county.

37-2.1-5. Definitions.

The following words and phrases when used in this chapter shall have, unless the context clearly indicates otherwise, the meanings given to them in this section:

- (a) "Person" means natural persons as well as corporations, partnerships, business units, and associations;
- (b) "Public agency" means (1) the state and its departments, boards, commissions and agencies, (2) cities, towns, school districts, and any other governmental unit or district, (3) any and all other public bodies, authorities, officers, agencies, or instrumentalities, whether exercising a governmental or proprietary function;
- (c) "Public works" means steel to construct, frame or reinforce any public structure, building, highway, waterway, street, bridge, transit system, airport, or other betterment, work or improvement, whether of a permanent or temporary nature, and whether for governmental or proprietary use;
- (d) "Steel products" means products rolled, formed, shaped, drawn, extruded, forged, cast, fabricated, or otherwise similarly processed, or processed by a combination of two or more of such operations, from steel made in the United States by the open hearth, basic oxygen, electric furnace, Bessemer, or other steel making process;
- (e) "United States" means the United States of America and includes all territory, continental or insular, subject to the jurisdiction of the United States.

TITLE 37

CHAPTER 12 CONTRACTORS' BONDS

Sections

- 37-12-1. Contractors required to give bond – Terms and conditions.
- 37-12-2. Rights of persons furnishing labor and materials.
- 37-12-3. Remedies of creditors and state – Priority of claims.
- 37-12-4. Intervention by creditor in suit brought by state.
- 37-12-5. Time limitation on creditors' actions.
- 37-12-6. Intervention in suit brought by creditor – Consolidation of suits.
- 37-12-7. Notice of Pendency of Suit
- 37-12-8. Certified copies of documents.
- 37-12-9. Payment into court by surety – Discharge.
- 37-12-10. Retainers relating to contracts for public works or sewer or water main construction.
- 37-12-11. Substitution of securities for retained earnings.

§ 37-12-1. Contractors required to give bond – Terms and conditions. – Every person (which word for the purposes of this chapter shall include a co-partnership, a number of persons engaged in a joint enterprise, or a corporation), before being awarded a contract by the department of transportation or by the department of administration, as the case may be, and every person awarded such a contract as a general contractor or construction or project manager for the construction, improvement, completion, or repair of any public road or portion thereof or of any bridge in which the contract price shall be in excess of fifty thousand dollars (\$ 50,000), or for a contract for the construction, improvement, completion, or repair of any public building, or portion thereof, shall be required to furnish to the respective department a bond of that person to the state, with good and sufficient surety or sureties (hereafter in this chapter referred to as surety), acceptable to the respective department, in a sum not less than fifty percent (50%) and not more than one hundred percent (100%) of the contract price, conditioned that the contractor, principal in the bond, the person's executors, administrators, or successors, shall in all things, well and truly keep and perform the covenants, conditions, and agreements in the contract, and in any alterations thereof made as therein provided, on the person's part to be kept and performed, at the time and in the manner therein specified, and in all respects according to their true intent and meaning, and shall indemnify and save harmless the state, the respective department, and all of its officers, agents, and employees, as therein stipulated, and shall also promptly pay for all such labor performed or furnished and for all such materials and equipment furnished, (which as to equipment shall mean payment of the reasonable rental value, as determined by the respective department, of its use during the period of its use), as shall be used in the carrying on of the work covered by the contract, or shall see that they are promptly paid for, whether or not the labor is directly performed for or furnished to the contractor or is even directly performed upon the work covered by the contract, and whether or not the materials are furnished to the contractor or become component parts of the work, and whether or not the equipment is furnished to the contractor or even directly used upon the work. The bond shall contain the provisions that it is subject to all such rights and powers of the respective department and such other provisions as are set forth in the contract and the plans, specifications, and proposal incorporated by reference in the contract, and that no extension of the time of performance of the contract or delay in the completion of the work thereunder or any alterations thereof, made as therein provided, shall invalidate the bond or release the liability of the surety thereunder. Waiver of the bonding requirements of this section is expressly prohibited.

37-12-2. Rights of persons furnishing labor and materials.

Every person who shall have performed labor and every person who shall have furnished or supplied labor, material, or equipment in the prosecution of the work provided for in the contract, in respect of which a payment bond is furnished under § 37-12-1, and who has not been paid in full therefor before the expiration of a period of ninety (90) days after the day on which the last of the labor was performed or furnished by him or her, or material or equipment furnished or supplied by him or her for which a claim is made, shall have the right to sue on the payment bond for the amount, or the balance thereof, unpaid at the time of institution of the suit and to prosecute the action to final execution and judgment for the sum or sums justly due him or her; provided, however, that any person having direct contractual relationship with a subcontractor but no contractual relationship express or implied with the contractor

furnishing the payment bond shall have a right of action upon the payment bond upon giving written notice to the contractor within ninety (90) days from the date on which the person furnished or performed the last of the labor, or furnished or supplied the last of the material or equipment for which the claim is made, stating with substantial accuracy the amount claimed and the name of the party to whom the labor was furnished or performed or the material or equipment was furnished or supplied. The notice shall be served by mailing the same by certified mail, postage prepaid, in an envelope addressed to the contractor at any place he or she maintains an office, conducts his or her business, or his or her residence.

37-12-3. Remedies of creditors and state - Priority of claims.

The remedy on the bond shall be by a civil action brought in the superior court for the counties of Providence and Bristol and in any suit brought on the bond the rights of the state shall be prior to those of all creditors. The rights of persons who shall have performed labor as aforesaid shall be prior to the rights of all other creditors, and there shall be no priorities among laborers or among other creditors under the bond. The state, either after having recovered a judgment against the contractor on the contract or without having recovered a judgment, may bring a suit on the bond against the contractor and surety on the bond, and may join as parties defendant in the suit any persons claiming to have rights under the bond as creditors; and, if it has not brought such a suit, it may at any time before a final and conclusive decree, intervene and become a party in any suit brought, as hereafter provided in this chapter, by any person claiming to be a creditor under the bond.

37-12-4. Intervention by creditor in suit brought by state.

Any person claiming to be a creditor under the bond may at any time intervene and become a party in any pending suit brought as aforesaid by the state on the bond, and by so intervening may have the rights to the person adjudicated in the suit.

37-12-5. Time limitation on creditors' actions.

No suit instituted under § 37-12-2 shall be commenced after the expiration of two (2) years, or under the maximum time limit as contained within any labor or material payment bond required under § 37-12-1, whichever period is longer, after the day on which the last of the labor was furnished or performed or material or equipment was furnished or supplied by any person claiming under the section.

37-12-6. Intervention in suit brought by creditor - Consolidation of suits.

When a suit has been so brought on the bond by a person claiming to be a creditor under the bond and is pending, any other person claiming to be a creditor under the bond may intervene and become a party in the first suit thus brought and pending and by so intervening may have the rights of the other person adjudicated in the suit. If two (2) or more of the suits be filed in the court on the same day, the one in which the larger sum shall be claimed shall be regarded as the earlier suit. All suits brought upon the bond as provided in this chapter shall be consolidated together by the court and heard as one suit.

37-12-7. Notice of pendency of suit.

In any suit brought under the provisions of this chapter such personal notice of the pendency of the suit as the court may order shall be given to all such known creditors and persons claiming to be creditors under the bond as shall not have entered their appearances in the suit and, in addition to the notice, notice of the pendency of the suit shall be given by publication in some newspaper published in this state of general circulation in the city or town or every city or town in which the work covered by the contract was carried on, once a week for three (3) successive weeks, in such form as the court may order. The court, however, may dispense with the notices if satisfied that sufficient notices shall have been given in some other suit brought under the provisions of this chapter.

37-12-8. Certified copies of documents.

Any person claiming to be a creditor under the bond and having filed a claim with the respective department, in accordance with the requirements of § 37-12-2, shall have the right, at any time when the person could under this chapter file a suit or intervene in a pending suit, to require the respective department to furnish to the person certified copies of the contract, proposal, plans specifications, and bond.

37-12-9. Payment into court by surety - Discharge.

The surety on the bond may pay into the registry of the court, for distribution among those who may be or become entitled thereto under the decree of the court, the penal sum named in the bond less any amount which the surety

may have paid to the state in satisfaction of the liability of the surety to the state under the bond, and then shall be entitled to be discharged from all further liability under the bond.

37-12-10. Retainers relating to contracts for public works or sewer or water main construction.

(a) Upon substantial completion of the work required by a contract aggregating in amount less than five hundred thousand dollars (\$ 500,000) with any municipality, or any agency or political subdivision thereof, for the construction, reconstruction, alteration, remodeling, repair, or improvement of sewers and water mains, or any public works project defined in, the awarding authority may deduct from its payment a retention to secure satisfactory performance of the contractual work not exceeding five percent (5%) of the contract price unless otherwise agreed to by the parties. Upon substantial completion of the work required by a contract aggregating in an amount of five hundred thousand dollars (\$ 500,000) or greater with any municipality, or any agency or political subdivision thereof, for the construction, reconstruction, alteration, remodeling, repair, or improvement of sewers and water mains, or any public works project defined in § 37-13-1, the awarding authority may deduct from its payment a retention to secure satisfactory performance of the contractual work not exceeding five percent (5%) of the contract price. In the case of periodic payments with respect to contracts less than the aggregate amount of five hundred thousand dollars (\$ 500,000), the awarding authority may deduct from its payment a retention to secure satisfactory performance of the contractual work not exceeding five percent (5%) of the approved amount of any periodic payment unless otherwise agreed to by the parties. In the case of periodic payments with respect to contracts in the aggregate amount of five hundred thousand dollars (\$ 500,000) or greater, the awarding authority may deduct from its payment a retention to secure satisfactory performance of the contractual work not exceeding five percent (5%) of the approved amount of any periodic payment.

(b) The retainage shall be paid to any contractor or subcontractor within ninety (90) days of the date the work is accepted by the awarding authority unless a dispute exists with respect to the work. If payment is not made within ninety (90) days for any reason other than a dispute, which, if resolved and it is not the fault of the contractor, interest shall be assessed at the rate of ten percent (10%) per annum on all money which is to be paid to the contractor or subcontractor.

(c) The retainage shall be paid to any contractor or subcontractor within ninety (90) days of the date his or her work is completed and accepted by the awarding authority. If payment is not made, interest shall be assessed at the rate of ten percent (10%) per annum.

(d) There shall also be deducted and retained from the contract price an additional sum sufficient to pay the estimated cost of municipal police traffic control on any public works project. Municipalities shall directly pay the officers working traffic details and shall bill and be reimbursed by the withholding authority for which the contract is being performed every thirty (30) days until the project is complete.

(e) Notwithstanding the foregoing, with respect to projects located within the town of Warren, the withholding authority shall hold an amount from the contract price which shall be reasonably sufficient to pay the estimated cost of municipal police traffic control. The withholding authority shall pay to the town of Warren within seventy-two (72) hours of written demand the actual costs of police traffic control associated with said project on an ongoing basis.

37-12-11. Substitution of securities for retained earnings.

(a) Where any public works contract as defined by § 37-13-1 provides for the retention of earned estimates by the state of Rhode Island, the contractor may, from time to time, withdraw the whole or any portion of the amount retained for payments to the contractor pursuant to the terms of the contract, upon depositing with the general treasurer either; (1) United States treasury bonds, United States treasury notes, United States treasury certificates of indebtedness, or United States treasury bills; (2) Bonds or notes of the state of Rhode Island ; or (3) Bonds of any political subdivision in the state of Rhode Island.

(b) No amount shall be withdrawn in excess of the market value of the securities at the time of deposit or of the par value of the securities, whichever is lower. The general treasurer shall, on a regular basis, collect all interest or income on the obligations so deposited and shall pay the interest or income, when and as collected, to the contractor who deposited the obligations. If the deposit is in the form of coupon bonds, the general treasurer shall deliver each coupon as it matures to the contractor. Any amount deducted by the state, or by any public department or official thereof, pursuant to the terms of the contract, from the retained payments otherwise due the contractor, shall be

deducted, first from that portion of the retained payments for which no security has been substituted, then from the proceeds of any deposited security. In the latter case, the contractor shall be entitled to receive interest, coupons, or income only from those securities which remain after the amount has been deducted. The securities so deposited shall be properly endorsed by the contractor in such manner so as to enable the general treasurer to carry out the provisions of this section.

TITLE 37

CHAPTER 12.1 SUBSTITUTION OF SECURITY FOR RETAINED EARNINGS OF ARCHITECTS AND ENGINEERS

Sections

- 37-12.1-1. Definition of Terms.
- 37-12.1-2. Substitution of security for retained earnings by designers.
- 37-12.1-3. Deduction from retained earnings.
- 37-12.1-4. Endorsement on securities.
- 37-12.1-5. Applicability.

37-12.1-1. Definition of terms.

Terms used in this chapter shall be construed as follows:

- (a) "Designers", means any person, firm or corporation duly authorized pursuant to the laws of this state to engage in the practice of architecture and/or engineering within this state.
- (b) "Public works contract" means a contract to perform design or planning services by a designer with the state or any agency or governmental subdivisions thereof.
- (c) "Retained earnings" means any moneys or earned estimates withheld from a designer pursuant to the terms of a public works contract.

37-12.1-2. Substitution of security for retained earnings by designers.

(a) Where any public works contract provides for the holding of retained earnings from a designer, the designer may from time to time withdraw the whole or any portion of the amount retained upon either depositing with the general treasurer:

- (1) United States treasury bonds, United States treasury notes, United States treasury certificates of indebtedness, or United States treasury bills;
- (2) Bonds or notes of the state of Rhode Island; or
- (3) Bonds of any political subdivision of the state of Rhode Island.

(b) With respect to the deposit of securities, the general treasurer shall, on a regular basis, collect all interest or income on the securities so deposited and shall pay the interest or income when and as collected to the designer depositing the securities. If the security is in the form of coupon bonds, the general treasurer shall deliver each coupon as it matures to the designer.

37-12.1-3. Deduction from retained earnings.

In the event that pursuant to the terms of the public works contract it is necessary to deduct any sum from retained earnings, the state or governmental unit or agency thereof shall first apply such deduction against sums not withdrawn and thereafter from the proceeds of the sale of any securities deposited or from the income earned on such securities, whichever is applicable.

37-12.1-4. Endorsement on securities.

All securities deposited with the general treasurer pursuant to this chapter shall be properly endorsed by the designer in such manner as to enable the general treasurer to carry out the provisions of this chapter.

37-12.1-5. Applicability.

This chapter shall apply to all retained earnings held pursuant to any public works contract as of [June 16, 1991].

TITLE 37

CHAPTER 13 LABOR AND PAYMENT OF DEBTS BY CONTRACTORS

Sections

- 37-13-1. "Public Works" defined
- 37-13-2. "Contractor" defined – information required.
- 37-13-3. Contractors subject to provisions – Weekly payment of employees.
- 37-13-3.1 State public works contract apprenticeship requirements
- 37-13-4. Provisions applicable to public works contracts – List of Subcontractors.
- 37-13-5. Payment for trucking or materials furnished – Withholding of sums due.
- 37-12-6. Ascertainment of prevailing rate of wages and other payments – Specification of rate in call for bids and in contract.
- 37-13-7. Specification in contract of amount and frequency of payment and wages.
- 37-13-8. Investigation and determination of prevailing wages – Filing of schedule.
- 37-13-9. Statutory provisions included in contracts.
- 37-13-10. Overtime compensation.
- 37-13-11. Posting of prevailing wage rates.
- 37-13-12. Wage records of contractors.
- 37-13-12.1. Obstruction of enforcement.
- 37-13-12.2. Subpoena powers.
- 37-13-12.3. Compelling obedience to subpoenas.
- 37-13-12.4. Penalty for violations.
- 37-13-13. Furnishing payroll record to director of labor.
- 37-13-13.1. Audits of wage records of out of state contractors and subcontractors.
- 37-13-14. Contractor's bond.
- 37-13-14.1. Enforcement – Hearings.
- 37-13-15. Review.
- 37-13-16. Termination of work on failure to pay agreed wages – Completion of work.
- 37-13-17. Private right of action to collect wages or benefits

37-13-1. "Public works" defined.

"Public works" as used in this chapter shall mean any public work consisting of grading, clearing, demolition, improvement, completion, repair, alteration, or construction of any public road or any bridge, or portion thereof, or any public building or portion thereof, or any heavy construction, or any public works projects of any nature or kind whatsoever.

37-13-2. "Contractor" defined - Information required.

The term "contractor" as used in this chapter shall mean the bidder whose bid has been accepted by an authorized agency or awarding authority as the bidder possessing the skills, ability, and integrity necessary to the faithful performance of the contract or work, and who shall certify that he or she is able to furnish labor that can work in harmony with all other elements of labor employed or to be employed on the contract or work. Essential information in regard to qualifications shall be submitted in such form to the awarding authority and the director of labor and training as the director of labor and training shall require. The authorized agency or awarding authority shall reserve the right to reject all bids, if it be in the public interest to do so.

37-13-3. Contractors subject to provisions - Weekly payment of employees.

All contractors, who have been awarded contracts for public works by an awarding agency or authority of the state or of any city, town, committee, or by any person or persons therein, in which state or municipal funds are used and of which the contract price shall be in excess of one thousand dollars (\$1,000) whether payable at the time of the signing of the contract or at a later date, and their subcontractors, on such public works shall pay their employees at weekly intervals and shall comply with the provisions set forth in 37-13-4 - 37-13-14, inclusive, and 37-13-16.

37-13-3.1. State public works contract apprenticeship requirements.

Notwithstanding any laws to the contrary, all general contractors and subcontractors who perform work on any public works contract awarded by the state after passage of this act and valued at one million dollars (\$ 1,000,000) or more shall employ apprentices required for the performance of the awarded contract. The number of apprentices shall comply with the apprentice to journeyman ratio for each trade approved by the apprenticeship council of the department of labor and training. To the extent that any of the provisions contained in this section conflict with the requirements for federal aid contracts, federal laws and regulations shall control.

37-13-4. Provisions applicable to public works contracts - Lists of subcontractors.

All public works shall be done by contract, subject to the same provisions of law relating thereto and to the letting thereof, which are applicable to similar contracts of the awarding authority or authorized agency, hereinafter called the "proper authority," in the general location where the work is to be performed and which are not contrary to the provisions of 37-13-1 - 37-13-14, and 37-13-16. Each contractor after the award of a contract for public works shall submit to the proper authority a list of his or her subcontractors of any part or all of the work. The list shall be submitted in such manner or form as the proper authority shall uniformly require from contractors in all public works.

37-13-5. Payment for trucking or materials furnished - Withholding of sums due.

A contractor or subcontractor on public works authorized by a proper authority shall pay any obligation or charge for trucking and material which have been furnished for the use of the contractor or subcontractor, in connection with the public works being performed by him or her, within ninety (90) days after the obligation or charge is incurred or the trucking service has been performed or the material has been delivered to the site of the work, whichever is later. When it is brought to the notice of the proper authority in a city or town, or the proper authority in the state having supervision of the contract, that the obligation or charge has not been paid by the contractor or subcontractor, the proper authority may deduct and hold for a period not exceeding sixty (60) days, from sums of money due to the contractor or subcontractor, the equivalent amount of such sums certified by a trucker or material man creditor as due him or her, as provided in this section, and which the proper authority determines is reasonable for trucking performed or materials furnished for the public works.

37-13-6. Ascertainment of prevailing rate of wages and other payments - Specification of rate in call for bids and in contract.

Before awarding any contract for public works to be done, the proper authority shall ascertain from the director of labor and training the general prevailing rate of the regular, holiday, and overtime wages paid and the general prevailing payments on behalf of employees only, to lawful welfare, pension, vacation, apprentice training, and educational funds (payments to the funds must constitute an ordinary business expense deduction for federal income tax purposes by contractors) in the city, town, village, or other appropriate political subdivision of the state in which the work is to be performed, for each craft, mechanic, teamster, laborer, or type of worker needed to execute the contract for the public works. The proper authority shall, also, specify in the call for bids for the contract and in the contract itself the general prevailing rate of the regular, holiday, and overtime wages paid and the payments on behalf of employees only, to the welfare, pension, vacation, apprentice training, and education funds existing in the locality for each craft, mechanic, teamster, laborer, or type of worker needed to execute the contract or work.

37-13-7. Specification in contract of amount and frequency of payment of wages.

Every call for bids for every contract in excess of one thousand dollars (\$ 1,000), to which the state of Rhode Island or any political subdivision thereof or any public agency or quasi-public agency is a party, for construction, alteration, and/or repair, including painting and decorating, of public buildings or public works of the state of Rhode Island or any political subdivision thereof, or any public agency or quasi-public agency and which requires or involves the employment of employees, shall contain a provision stating the minimum wages to be paid various types of employees which shall be based upon the wages that will be determined by the director of labor and training to be prevailing for the corresponding types of employees employed on projects of a character similar to the contract work in the city, town, village, or other appropriate political subdivision of the state of Rhode Island in which the work is to be performed. Every contract shall contain a stipulation that the contractor or his or her subcontractor shall pay all the employees employed directly upon the site of the work, unconditionally and not less often than once a week, and without subsequent deduction or rebate on any account, the full amounts accrued at time of payment computed at wage rates not less than those stated in the call for bids, regardless of any contractual relationships which may be alleged to exist between the contractor or subcontractor and the employees, and that the scale of wages to be paid shall be posted by the contractor in a prominent and easily accessible place at the site of the work; and the further stipulation that there may be withheld from the contractor so much of the accrued payments as may be considered necessary to pay to the employees employed by the contractor, or any subcontractor on the work, the difference between the rates of wages required by the contract to be paid the employees on the work and the rates of wages received by the employees and not refunded to the contractor, subcontractors, or their agents.

(b) The terms "wages" , "scale of wages" , "wage rates" , "minimum wages" , and "prevailing wages" shall include:

(1) The basic hourly rate of pay; and

(2) The amount of:

(A) The rate of contribution made by a contractor or subcontractor to a trustee or to a third person pursuant to a fund, plan, or program; and

(B) The rate of costs to the contractor or subcontractor which may be reasonably anticipated in providing benefits to employees pursuant to an enforceable commitment to carry out a financially responsible plan or program which was communicated in writing to the employees affected, for medical or hospital care, pensions on retirement or death, compensation for injuries or illness resulting from occupational activity, or insurance to provide any of the foregoing, for unemployment benefits, life insurance, disability and sickness insurance, or accident insurance, for vacation and holiday pay, for defraying costs of apprenticeship or other similar programs, or for other bona fide fringe benefits, but only where the contractor or subcontractor is not required by other federal, state, or local law to provide any of the benefits ; provided, that the obligation of a contractor or subcontractor to make payment in accordance with the prevailing wage determinations of the director of labor and training insofar as this chapter of this title and other acts incorporating this chapter of this title by reference are concerned may be discharged by the making of payments in cash, by the making of contributions of a type referred to in subsection (b)(2), or by the assumption of an enforceable commitment to bear the costs of a plan or program of a type referred to in this subdivision, or any combination thereof, where the aggregate of any payments, contributions, and costs is not less than the rate of pay described in subsection (b)(1) plus the amount referred to in subsection (b)(2).

(c) The term "employees" , as used in this section, shall include employees of contractors or subcontractors performing jobs on various types of public works including mechanics, apprentices, teamsters, chauffeurs, and laborers engaged in the transportation of gravel or fill to the site of public works, the removal and/or delivery of gravel or fill or ready-mix concrete, sand, bituminous stone, or asphalt flowable fill from the site of public works, or the transportation or removal of gravel or fill from one location to another on the site of public works, and the employment of the employees shall be subject to the provisions of subsections (a) and (b) .

(d) The terms "public agency" and "quasi-public agency" shall include, but not be limited to, the Rhode Island industrial recreational building authority, the Rhode Island economic development corporation, the Rhode Island airport corporation, the Rhode Island industrial facilities corporation, the Rhode Island refunding bond authority, the Rhode Island housing and mortgage finance corporation, the Rhode Island resource recovery corporation, the Rhode Island public transit authority, the Rhode Island student loan authority, the water resources board corporate, the Rhode Island health and education building corporation, the Rhode Island turnpike and bridge authority, the Narragansett Bay water quality management district commission, Rhode Island telecommunications authority, the

convention center authority, the board of governors for higher education, the board of regents for elementary and secondary education, the capital center commission, the housing resources commission, the Quonset Point-Davisville management corporation, the Rhode Island children's crusade for higher education, the Rhode Island depositors economic protection corporation, the Rhode Island lottery commission, the Rhode Island partnership for science and technology, the Rhode Island public building authority, and the Rhode Island underground storage tank board.

37-13-8. Investigation and determination of prevailing wages - Filing of schedule.

The director of labor and training shall investigate and determine the prevailing wages and payments made to or on behalf of employees, as set forth in § 37-13-7, paid in the trade or occupation in the city, town, village, or other appropriate political subdivision of the state and keep a schedule on file in his or her office of the customary prevailing rate of wages and payments made to or on behalf of the employees which shall be open to public inspection. In making a determination, the director of labor may adopt and use such appropriate and applicable prevailing wage rate determinations as have been made by the secretary of labor of the United States of America in accordance with the Davis-Bacon Act, as amended, 40 U.S.C. § 276a; provided, however, that each contractor awarded a public works contract after July 1, 2007 shall contact the department of labor and training on or before July first of each year, for the duration of such contract to ascertain the prevailing wage rate of wages on a hourly basis and the amount of payment or contributions paid or payable on behalf of each mechanic, laborer or worker employed upon the work contracted to be done each year and shall make any necessary adjustments to such prevailing rate of wages and such payment or contributions paid or payable on behalf of each such employee every July first.

37-13-9. Statutory provisions included in contracts.

A copy of 37-13-5, 37-13-6, and 37-13-7 shall be inserted in all contracts for public works awarded by the state or any city or town, committee, an authorized agency or awarding authority thereof, or any person or persons in their behalf in which state or municipal funds are used if the contract price be in excess of one thousand dollars (\$1,000).

37-13-10. Overtime compensation.

Labor performed under the provisions of 37-13-1 - 37-13-16, inclusive, during the period of forty (40) hours in any one week and during the period of eight (8) hours in any one day, shall be considered a legal week's work or a legal day's work, as the case may be, and any number of hours of employment in any one week greater than the number of forty (40) hours or in any one day greater than the number of eight (8) hours shall be compensated at the prevailing rate of wages for overtime employment; provided, however, when the director of labor and training has determined in the investigation provided for in 37-13-7 and 37-13-8 that there is a prevailing practice in a city, town, or other appropriate political subdivision to pay an overtime rate of wages for work of any craft, mechanic, teamster, laborer, or type of worker needed to execute the work other than hours worked in any one week greater than the number of forty (40) or in hours worked in any one day greater than the number of eight (8), then the prevailing practice shall determine the legal workday and the legal workweek in the city or town for the work and the prevailing rate of overtime wages shall be paid for such work in excess of that legal workday or week, as the case may be.

37-13-11. Posting of prevailing wage rates.

Each contractor awarded a contract for public works with a contract price in excess of one thousand dollars (\$ 1,000), and each subcontractor who performs work on those public works, shall post in conspicuous places on the project, where covered workers are employed, posters which contain the current, prevailing rate of wages and the current, prevailing rate of payments to the funds required to be paid for each craft or type of worker employed to execute the contract as set forth in §§ 37-13-6 and 37-13- 7, and the rights and remedies of any employee described in § 37-13-17 for nonpayment of any wages earned pursuant to this chapter. Posters shall be furnished to contractors and subcontractors by the director of labor and training, who shall determine the size and context thereof from time to time, at the time a contract is awarded. A contractor or subcontractor who fails to comply with the provisions of this section shall be deemed guilty of a misdemeanor and shall pay to the director of labor and training one hundred dollars (\$ 100) for each calendar day of noncompliance as determined by him or her. Contracts set forth in this section shall not be awarded by the state, any city, town, or any agency thereof until the director of labor and training has prepared and delivered the posters to the division of purchases, if the state or any agency thereof is the proper authority, or to the city, town, or an agency thereof, if it is the proper authority, and the contractor to whom the contract is to be awarded.

37-13-12. Wage records of contractors.

Each contractor awarded a contract with a contract price in excess of one thousand dollars (\$1,000) for public works, and each subcontractor who performs work on those public works, shall keep an accurate record showing the name, occupation, and actual wages paid to each worker employed by him or her and the payments to all the employee funds specified in sections 37-13-6 and 37-13-7 by him or her in connection with the contract or work. The director and his or her authorized representatives shall have the right to enter any place of employment at all reasonable hours for the purpose of inspecting the wage records and seeing that all provisions of this chapter are complied with.

37-13-12.1. Obstruction of enforcement.

Any effort of any employer to obstruct the director and his or her authorized representatives in the performance of their duties shall be deemed a violation of this chapter and punishable as such.

37-13-12.2. Subpoena powers.

The director and his or her authorized representatives shall have power to administer oaths and examine witnesses under oath, issue subpoenas, subpoenas duces tecum, compel the attendance of witnesses, and the production of papers, books, accounts, records, payrolls, documents, and testimony, and to take depositions and affidavits in any proceeding before the director.

37-13-12.3. Compelling obedience to subpoenas.

In case of failure of any person to comply with any subpoena lawfully issued, or subpoena duces tecum, or on the refusal of any witness to testify to any matter regarding which he may be lawfully interrogated, it shall be the duty of the superior court, or any judge thereof, on application by the director, to compel obedience by proceedings in the nature of those for contempt.

37-13-12.4. Penalty for violations.

Except as otherwise provided in this chapter, any employer who shall violate or fail to comply with any of the provisions of this chapter shall be guilty of a misdemeanor and shall be punished by a fine of not less than five hundred dollars (\$500) nor more than one thousand dollars (\$1,000) for each separate offense, or by imprisonment of up to one year, or by both fine and imprisonment. Each day of failure to pay wages due an employee at the time specified in this chapter shall constitute a separate and distinct violation.

37-13-13. Furnishing payroll record to director of labor.

(a) Every contractor and subcontractor awarded a contract for public works as defined by this chapter shall furnish a certified copy of his or her payroll records of his or her employees employed on the project to the awarding authority on a monthly basis for all work completed in the preceding month on a uniform form prescribed by the director of labor and training. Notwithstanding the foregoing, certified payrolls for department of transportation public works may be submitted on the federal payroll form, provided that, when a complaint is being investigated, the director or his or her designee may require that a contractor resubmit the certified payroll on the uniform department form.

(b) Awarding authorities, contractors and subcontractors shall provide any and all payroll records to the director of labor and training within ten (10) days of their request by the director or his or her designee.

(c) In addition, every contractor and subcontractor shall maintain on the site where public works are being constructed and the general or primary contract is one million dollars (\$1,000,000) or more, a daily log of employees employed each day on the public works project. The log shall include, at a minimum, for each employee his or her name, primary job title, and employer and shall be kept on a uniform form prescribed by the director of labor and training. Such log shall be available for inspection on the site at all times by the awarding authority and/or the director of the department of labor and training and his or her designee. This subsection shall not apply to road, highway, or bridge public works projects.

(d) The director of labor and training may promulgate reasonable rules and regulations to enforce the provisions of this section.

(e) The awarding authority of any public works project shall withhold the next scheduled payment to any contractor or subcontractor who fails to comply with the provisions of subsections (a) or (b) above and shall also

notify the director of labor and training. The awarding authority shall withhold any further payments until such time as the contractor or subcontractor has fully complied. If it is a subcontractor who has failed to comply, the amount withheld shall be proportionate to the amount attributed or due to the offending subcontractor as determined by the awarding authority. The department may also impose a penalty of up to five hundred dollars (\$500) for each calendar day of noncompliance with this section, as determined by the director of labor and training. Mere errors and/or omissions in the daily logs maintained under subsection (c) shall not be grounds for imposing a penalty under this subsection.

37-13-13.1. Audits of wage records of out of state contractors and subcontractors.

Out of state contractors or subcontractors who perform work on public works in this state authorize the director of labor and training to conduct wage and hour audits of their payroll records pursuant to the provisions of chapter 14 of title 28.

37-13-14. Contractor's bond.

The state or any city, town, agency, or committee therein awarding contracts for public works shall require the contractor awarded a contract with a contract price in excess of fifty thousand dollars (\$ 50,000) for public works to file with the proper authority good and sufficient bond with surety furnished by any surety company authorized to do business in the state, conditioned upon the faithful performance of the contract and upon the payment for labor performed and material furnished in connection therewith, a bond to contain the terms and conditions set forth in chapter 12 of this title, and to be subject to the provisions of that chapter. Waiver of the bonding requirements of this section is expressly prohibited.

37-13-14.1. Enforcement - Hearing

(a) Before issuing an order or determination, the director of labor and training shall order a hearing thereon at a time and place to be specified, and shall give notice thereof, together with a copy of the complaint or the purpose thereof, or a statement of the facts disclosed upon investigation, which notice shall be served personally or by mail on any person, firm, or corporation affected thereby. The person, firm, or corporation shall have an opportunity to be heard in respect to the matters complained of at the time and place specified in the notice, which time shall be not less than five (5) days from the service of the notice personally or by mail. The hearing shall be held within ten (10) days from the order of hearing. The hearing shall be conducted by the director of labor and training or his or her designee. The hearing officer in the hearing shall be deemed to be acting in a judicial capacity and shall have the right to issue subpoenas, administer oaths, and examine witnesses. The enforcement of a subpoena issued under this section shall be regulated by Rhode Island civil practice law and rules. The hearing shall be expeditiously conducted, and upon such hearing, the hearing officer shall determine the issues raised thereon and shall make a determination and enter an order within ten (10) days of the close of the hearing, and forthwith serve a copy of the order, with a notice of the filing thereof, upon the parties to the proceeding, personally or by mail. The order shall dismiss the charges or direct payment of wages or supplements found to be due, including interest at the rate of twelve percent (12%) per annum from the date of the underpayment to the date of payment, and may direct payment of reasonable attorney's fees and costs to the complaining party.

(b) In addition to directing payment of wages or supplements including interest found to be due, the order shall also require payment of a further sum as a civil penalty in an amount up to three times the total amount found to be due. Further, if the amount of salary owed to an employee pursuant to this chapter but not paid to the employee in violation of thereof exceeds five thousand dollars (\$5,000), it shall constitute a misdemeanor and shall be referred to the office of the attorney general. The misdemeanor shall be punishable for a period of not more than one year in prison and/or fined not more than one thousand dollars (\$1,000). In assessing the amount of the penalty, due consideration shall be given to the size of the employer's business, the good faith of the employer, the gravity of the violation, the history of previous violations, and the failure to comply with recordkeeping or other nonwage requirements. The surety of the person, firm, or corporation found to be in violation of the provisions of this chapter shall be bound to pay any penalties assessed on such person, firm, or corporation. The penalty shall be paid to the department of labor and training for deposit in the state treasury; provided, however, it is hereby provided that the general treasurer shall establish a dedicated "prevailing wages enforcement fund" for the purpose of depositing the penalties paid as provided herein. There is hereby appropriated to the annual budget of the department of labor and training the amount of the fund collected annually under this section, to be used at the direction of the director of labor and training for the sole purpose of enforcing prevailing wage rates as provided in this chapter.

(c) For the purposes of this chapter, each day or part thereof of violation of any provision of this chapter by a person, firm, or corporation, whether the violation is continuous or intermittent, shall constitute a separate and succeeding violation.

(d) In addition to the above, any person, firm, or corporation found in violation of any of the provisions of this chapter by the director of labor and training, an awarding authority, or the hearing officer, shall be ineligible to bid on, or be awarded work by, an awarding authority or perform any such work for a period of no less than eighteen (18) months and no more than thirty-six (36) months from the date of the order entered by the hearing officer. Once a person, firm, or corporation is found to be in violation of this chapter, all pending bids with any awarding authority shall be revoked, and any bid awarded by an awarding authority prior to the commencement of the work shall also be revoked.

(e) In addition to the above, any person, firm, or corporation found to have committed two (2) or more willful violations in any period of eighteen (18) months of any of the provisions of this chapter by the hearing officer, which violations are not arising from the same incident, shall be ineligible to bid on, or be awarded work by, an awarding authority or perform any work for a period of sixty (60) months from the date of the second violation.

(f) The order of the hearing officer shall remain in full force and effect unless stayed by order of the superior court.

(g) The director of labor and training, awarding authority, or hearing officer shall notify the bonding company of any person, firm, or corporation suspected of violating any section of this chapter. The notice shall be mailed certified mail and shall enumerate the alleged violations being investigated.

(h) In addition to the above, any person, firm, or corporation found to have willfully made a false or fraudulent representation on certified payroll records shall be referred to the office of the attorney general. A first violation of this section shall be considered a misdemeanor and shall be punishable for a period of not more than one year in prison and/or fined one thousand dollars (\$1,000). A second or subsequent violation of this section shall be considered a felony and shall be punishable for a period of not more than three (3) years imprisonment, a fine of three thousand dollars (\$3,000), or both. Further, any person, firm, or corporation found to have willfully made a false or fraudulent representation on certified payroll records shall be required to pay a civil penalty to the department of labor and training in an amount of no less than two thousand dollars (\$2,000) and not greater than fifteen thousand dollars (\$15,000) per representation.

37-13-15. Review.

(a) There is hereby created an appeals board which shall be comprised of three (3) members who shall be appointed by the governor; provided, however, that each member of the appeals board shall have at least five (5) years experience with prevailing wage rates as they apply to the construction industry. The members of such appeals board shall serve without compensation. The members of the appeals board shall be appointed for terms of three (3) years except that of the three (3) members originally appointed by each of the appointing authorities; one (1) shall be appointed for a term of one (1) year, one (1) shall be appointed for a term of two (2) years and one (1) for a term of three (3) years.

(b) Any person aggrieved by any action taken by the director of labor and training or his or her designated hearing officer under the authority of this chapter, or by the failure or refusal of the director of labor and training to take any action authorized by this chapter, may obtain a review thereof for the purpose of obtaining relief from the action or lack of action by filing a petition for administrative review and relief, to the appeals board as provided herein. The petition for administrative review shall be filed within twenty (20) days of the action taken by the director of labor and training or designated hearing officer: The petition for administrative review shall be heard within ten (10) days of the date of filing. An aggrieved person under this section shall include:

- (1) Any person who is required to pay wages to his or her employees or make payments to a fund on behalf of his or her employees, as provided in this chapter;
- (2) Any person who is required to be paid wages for his or her labor or on whose behalf payments are required to be paid to funds, as provided by this chapter;
- (3) The lawful collective bargaining representative of a person defined in subdivision (2) above;
- (4) A trade association of which a person defined in subdivision (1) above is a member;
- (5) A proper authority as defined in this chapter;

- (6) A contractor who submitted a bid for work to be or which has been awarded under the provisions of this chapter or a trade association of which he or her is a member, and
 - (7) A labor organization which has one or more written collective bargaining agreements with one or more employers or a trade association which sets forth the hours, wages, and working conditions of a craft, mechanic, teamster, or type of worker needed to execute the work, as provided in this chapter to the extent that it would be affected by the action or the failure to act of the director of labor and training or the hearing officer.
- (c) Any aggrieved person as defined herein may obtain a review of a decision of the appeals board by filing a petition in the superior court in Providence county pursuant to the provisions of the administrative procedures act, praying for review and relief and the petition shall follow the course of and be subject to the procedures for causes filed in the court.
- (d) The director is hereby empowered to enforce his or her decision and/or the decision of the appeals board in the superior court for the county of Providence.

37-13-16. Termination of work on failure to pay agreed wages - Completion of work.

Every contract within the scope of this chapter shall contain the further provision that in the event it is found by the director of labor and training that any employee employed by the contractor or any subcontractor directly on the site of the work covered by the contract has been or is being paid a rate of wages less than the rate of wages required by the contract to be paid as aforesaid, the awarding party may, by written notice to the contractor or subcontractor, terminate his or her right as the case may be, to proceed with the work, or such part of the work as to which there has been a failure to pay the required wages, and shall prosecute the work to completion by contract or otherwise, and the contractor and his or her sureties shall be liable to the awarding party for any excess costs occasioned the awarding authority thereby.

37-13-17. Private right of action to collect wages or benefits

(a) An employee or former employee, or any organization representing such an employee or former employee, of a contractor or subcontractor may bring a civil action for a violation of § 37-13-7 for appropriate injunctive relief, or actual damages, or both within three (3) years after the occurrence of the alleged violation. An action commenced pursuant to this section, may be brought in the superior court for the county where the alleged violation occurred, the county where the complainant resides, or the county where the person against whom in the civil complaint is filed resides or has their principal place of business. Any contractor or subcontractor who violates the provisions of § 37-13-7 shall be liable to the affected employee or employees in the amount of unpaid wages or benefits, plus interest. A civil action filed in court under this section may be instituted instead of, but not in addition to the director of labor and training enforcement procedures authorized by § 37-13-14.1, provided the civil action is filed prior to the date the director of labor and training issues notice of an administrative hearing.

(b) An employer's responsibility and liability is solely for its own employees.

(c) An action instituted pursuant to this section may be brought by one or more employees or former employees on behalf of himself/herself or themselves and other employees similarly situated, except that no employee shall be a party plaintiff to any such action unless he/she gives his/her consent in writing to become such a party and such consent is filed in the court in which such action is brought.

(d) In an action filed under this section in which the plaintiff prevails, the court shall, in addition to any judgment awarded to the plaintiff, require reasonable attorneys' fees and the costs of the action to be paid by the defendant.

(e) The court in an action filed under this section shall award affected employees or former employees liquidated damages in an amount equal to two (2) times the amount of unpaid wages or benefits owed. Unpaid fringe benefit contributions owed pursuant to this section in any form shall be paid to the appropriate benefit fund, however, in the absence of an appropriate fund the benefit shall be paid directly to the individual.

(f) The filing of a civil action under this section shall not preclude the director of labor and training from referring a matter to the attorney general as provided in § 37-13-14.1(b), from prohibiting a contractor or subcontractor from bidding on or otherwise participating in contracts as provided in § 37-13-14.1(d), (e) and (h), or from prohibiting termination of work on failure to pay agreed wages pursuant to § 37-13-16.

(g) Any person, firm, or corporation found to have willfully made a false or fraudulent representation in connection with wage obligations owed on a contract shall be required to pay a civil penalty to the department of labor and training in an amount of no less than one thousand dollars (\$ 1,000) and not greater than three thousand dollars (\$ 3,000) per representation. Such penalties shall be recoverable in civil actions filed pursuant to this section. For purposes of this subsection "willfully" shall mean representations that are known to be false, or representations made with deliberate ignorance or reckless disregard for their truth or falsity.

(h) An employer shall not discharge, threaten, or otherwise discriminate against an employee, or former employee, regarding compensation terms, conditions, locations or privileges of employment because the employee or former employee, or a person or organization acting on his or her behalf: (1) Reports or makes a complaint under this section; or otherwise asserts his or her rights under this section; and/or (2) Participates in any investigation, hearing or inquiry held by the director of labor and training under § 37-13-14.1. In the event a contractor or subcontractor retaliates or discriminates against an employee in violation of this section, the affected employee may file an action in any court of competent jurisdiction and the court shall order reinstatement and/or restitution of the affected employee, as appropriate, with back pay to the date of the violation, and an additional amount in liquidated damages equal to two (2) times the amount of back pay and reasonable attorneys' fees and costs.

(i) If any one or more subsections of this section shall for any reason be adjudged unconstitutional or otherwise invalid, the judgment shall not affect, impair, or invalidate the remaining subsections.

PREVAILING WAGE RATES

(THE PREVAILING WAGE RATES THAT ARE IN EFFECT AT THE TIME THAT THE PROJECT GOES OUT TO BID MUST BE INCLUDED IN THE BID SPECIFICATIONS)

Find current prevailing wage rates using the Department of Labor and Training website:

<https://dlt.ri.gov/regulation-and-safety/prevailing-wage>

TITLE 37

CHAPTER 14.1 MINORITY BUSINESS ENTERPRISE

Sections

37-14.1-1.	Purpose.
37-14.1-2.	Applicability.
37-14.1-3.	Definitions.
37-14.1-4.	Policy.
37-14.1-5.	Discrimination prohibited.
37-14.1-6.	Minority business enterprise guidelines.
37-14.1-7.	Establishment of criteria and guidelines.
37-14.1-8.	Sanctions.

37-14.1-1. Purpose.

The purpose of this chapter is to carry out the state's policy of supporting the fullest possible participation of firms owned and controlled by minorities and women (MBE's), in state funded and state directed public construction programs and projects and in state purchases of goods and services. This includes assisting MBE's throughout the life of contracts in which they participate.

37-14.1-2. Applicability.

This chapter shall apply to any and all state purchasing, including, but not limited to the procurement of goods, services, construction projects, or contracts funded in whole or in part by state funds, or funds which, in accordance with a federal grant or otherwise, the state expends or administers or in which the state is a signatory to the construction contract.

37-14.1-3. Definitions.

- (a) "Affirmative action" means taking specific steps to eliminate discrimination and its effects, to ensure nondiscriminatory results and practices in the future, and to involve minority business enterprises fully in contracts and programs funded by the state.
- (b) "Compliance" means the condition existing when a contractor has met and implemented the requirements of this chapter.
- (c) "Contract" means a mutually binding legal relationship or any modification thereof obligating the seller to furnish supplies or services, including construction, and the buyer to pay for them. For purposes of this chapter, a lease is a contract.
- (d) "Contractor" means one who participates, through a contract or subcontract, in any procurement or program covered by this chapter, and includes lessees and material suppliers.
- (e) "Minority" means a person who is a citizen or lawful permanent resident of the United States and who is:
 - (1) Black (a person having origins in any of the black racial groups of Africa);
 - (2) Hispanic (a person of Mexican, Puerto Rican, Cuban, Central or South American, or other Spanish culture or origin, regardless of race);
 - (3) Portuguese (a person of Portuguese, Brazilian, or other Portuguese culture or origin, regardless of race);
 - (4) Asian American (a person having origins in any of the original peoples of the Far East, Southeast Asia, the Indian subcontinent, or the Pacific Islands);
 - (5) American Indian and Alaskan Native (a person having origins in any of the original peoples of North America.); or
 - (6) Members of other groups, or other individuals, found to be economically and socially disadvantaged by the Small Business Administration under section 8(a) of the Small Business Act, as amended [15 U.S.C. 637(a)].
- (f) "Minority business enterprise" or "MBE" means a small business concern, as defined pursuant to section 3 of the federal Small Business Act [15 U.S.C. 632] and implementing regulations, which is owned and controlled by one or more minorities or women. For the purposes of this chapter, owned and controlled means a business.

- (1) Which is at least fifty-one percent (51%) owned by one or more minorities or women or, in the case of a publicly owned business, at least fifty-one percent (51%) of the stock of which is owned by one or more minorities or women; and
- (2) Whose management and daily business operations are controlled by one or more such individuals.

(g) "MBE coordinator" means the official designated to have overall responsibility for promotion of minority business enterprise in his or her departmental element.

(h) "Noncompliance" means the condition existing when a recipient or contractor has failed to implement the requirements of this chapter.

37-14.1-4. Policy.

It is the policy of the state of Rhode Island that minority business enterprises (MBE's) shall have the maximum opportunity to participate in the performance of procurements and projects outlined in 37-14.1-2.

37-14.1-5. Discrimination prohibited.

No person shall be excluded from participation in, denied the benefits of, or otherwise discriminated against in connection with the award and performance of any project covered by this chapter, on the grounds of race, color, national origin, or sex.

37-14.1-6. Minority business enterprise participation.

Minority business enterprises shall be included in all procurements and construction projects under this chapter and shall be awarded a minimum of ten percent (10%) of the dollar value of the entire procurement or project. The director of the department of administration is further authorized to establish by rules and regulation formulas for giving minority business enterprises a preference in contract and subcontract awards.

37-14.1-7. Establishment of criteria and guidelines.

The director of the department of administration shall establish, by rule and regulations adopted in accordance with chapter 35 of title 42, standards which shall determine whether a construction project is covered by this chapter, compliance formulas, procedures for implementation, and procedures for enforcement which are not inconsistent with 49 CFR 23 of the federal regulations. As to Rhode Island department of transportation contracts, the director of administration may delegate this authority to the director of transportation.

37-14.1-8. Sanctions.

(a) The director of the department of administration shall have the power to impose sanctions upon contractors not in compliance with this chapter and shall include but not be limited to:

- (1) Suspension of payments;
- (2) Termination of the contract;
- (3) Recovery by the state of ten percent (10%) of the contract award price as liquidated damages; and
- (4) Denial of right to participate in future projects for up to three (3) years.

(b) As to Rhode Island department of transportation contracts, the director of the department of administration may delegate this authority to the director of transportation.

RHODE ISLAND REQUIREMENTS FOR PARTICIPATION BY MINORITY BUSINESS ENTERPRISES
IN STATE FUNDED AND DIRECTED PUBLIC CONSTRUCTION PROJECTS, CONSTRUCTION
CONTRACTS AND PROCUREMENT CONTRACTS

In accordance with RI Gen. Law § 37-14.1-1, it is the policy of the State of Rhode Island to support the fullest possible participation of firms owned and controlled by minorities (MBEs) and women (WBEs). Pursuant to §§ 37-14.1-2 and 37-14.1-6, MBEs and WBEs shall be included in all state purchasing, including, but not limited to, the procurement of goods, services, construction projects, or contracts funded in whole or in part with state funds, or funds which, in accordance with a federal grant or otherwise, the state expends or administers. MBEs and WBEs shall be awarded a minimum of ten percent (10%) of the dollar value of the entire procurement or project. MBE participation credit shall only be granted for firms duly certified as MBEs or WBEs by the State of Rhode Island, Department of Administration, Office of Diversity, Equity and Opportunity, MBE Compliance Office (MBECO). The current directory of firms certified as MBEs or WBEs may be accessed at <http://odeo.ri.gov/offices/mbeco/mbe-wbe.php> or by contacting Kate Constance Brody, Esq. Administrator at the MBECO at (401) 574-8670 or via email at Kate.Brody@doa.ri.gov.

TITLE 37

CHAPTER 16 PUBLIC WORKS ARBITRATION

Sections

37-16-1.	Short Title.
37-16-2.	Contract provisions for arbitration.
37-16-3.	Application for subcontracts.
37-16-4.	Stay of legal proceedings pending arbitration.
37-16-5.	Jurisdiction of superior court to enforce arbitration provisions and awards.
37-16-6.	Trial upon evidence of substantial issue.
37-16-7.	Method of appointing arbitrators.
37-16-8.	Scheduling and notice of arbitration hearing – Adjournment.
37-16-9.	Power of court to direct prompt hearing.
37-16-10.	Arbitrator's oath – Waiver.
37-16-11.	Powers of arbitrators.
37-16-12.	Fees.
37-16-13.	Validity of awards.
37-16-14.	Arbitration under chapter deemed special proceeding – Jurisdiction of superior court.
37-16-15.	Procedure for hearing of application to court.
37-16-16.	Form of award.
37-16-17.	Court order confirming award.
37-16-18.	Court order vacating award.
37-16-19.	Rehearing after vacation of award.
37-16-20.	Court order modifying or correcting award.
37-16-21.	Notice of motion to vacate, modify, or correct an award.
37-16-22.	Entry of judgment – Costs
37-16-23.	Filing of papers after judgment.
37-16-24.	Effect of judgment.
37-16-25.	Appeals.
37-16-26.	Satisfaction of award.
37-16-27.	Application of sureties.

37-16-1. Short title.

This chapter shall be known as the "Public Works Arbitration Act".

37-16-2. Contract provision for arbitration.

(a) A provision in a written contract executed on or after January 1, 1962, for the construction, alteration, repair, or painting of any public building, sewer, highway, bridge, water treatment or disposal projects one party to which is the state, a city, a town, or an authority, a board, a public corporation, or any similar body created by statute or ordinance or any committee, agency, or subdivision of any of them, to settle by arbitration any dispute or claim arising out of or concerning the performance or interpretation of the contract shall be valid, irrevocable, and enforceable, save upon grounds existing in law or equity for the revocation of the contract.

(b) (1) Every contract for the construction, alteration, repair, painting, or demolition of any public building, sewer, water treatment or disposal project, highway, or bridge one party to which is the state, a city, a town, or an authority, a board, a public corporation, or any similar body created by statute or ordinance or any committee, agency, or subdivision of any of them which has a contract price of ten thousand dollars (\$ 10,000) or more and which is executed on or after July 1, 1967, shall contain a provision for arbitration of disputes and claims arising out of or concerning the performance or interpretation of the contract as follows:

(2) "All claims, disputes, and other matters in question arising out of or relating to this contract or the performance or interpretation thereof shall be submitted to arbitration. Arbitration shall be commenced by a demand in writing made by one party to the contract upon the other within a reasonable time after the dispute, claim, or other matter in question arose but in no event after payment in full of the contract price has been made and accepted. The written demand shall contain a statement of the question to be arbitrated and a detailed statement of each item or matter in

dispute and the name of the arbitrator appointed by that party. The other party to the contract within ten (10) days of the receipt of the written demand shall appoint an arbitrator and give notice in writing thereof to the party who commenced arbitration. The two (2) arbitrators appointed by the parties shall within ten (10) days of the date of the appointment of the second arbitrator select a third arbitrator who shall be designated as chairperson and who immediately shall give written notice to the parties of his or her appointment. The third arbitrator shall select a time, date, and place for hearing and give each party five (5) days notice in writing thereof. The date for hearing shall not be more than fifteen (15) days after the date of appointment of the third arbitrator. The award shall be made promptly by the arbitrators and, unless otherwise agreed by the parties or specified by law, no later than thirty (30) days from the date of closing the hearing, or, if oral hearings have been waived, from the date of the transmittal of the final statements and proofs to the arbitrators. The award shall be in writing and shall be signed by a majority of the arbitrators. It shall be executed in the manner required by law. The arbitrator shall provide a written explanation of the reasoning for the award. In the event the party of whom arbitration is demanded shall fail to appoint his or her arbitrator within the time specified or the two (2) arbitrators appointed by the parties are unable to agree on an appointment of the third arbitrator within the time specified, either party may petition the presiding justice of the superior court to appoint a single arbitrator who shall hear the parties and make an award as provided herein. The petitioner shall give five (5) days notice in writing to the other party before filing his or her petition."

(c) Any dispute involving claims less than one hundred thousand dollars (\$ 100,000) and associated with construction of a highway or bridge as referred to in subsection (b) shall be submitted to arbitration. Any dispute involving claims of one hundred thousand dollars (\$ 100,000) or more and associated with construction of a highway or bridge as referred to in subsection (b) shall only be arbitrated with the consent of the parties. If the parties fail to consent to arbitration and the state of Rhode Island is a party to the dispute, then the claim will proceed in accordance with § 37-13.1-1.

(d) For the purposes of this section, the term "claims" shall not mean the aggregate amount sought under the contract or in the arbitration, but shall refer specifically to each item or matter in dispute for which additional compensation is sought or for each item for which a credit is sought.

(e) Notwithstanding subsection (a) or (b) of this section, if any contract except for highway and bridge contracts provides for an arbitration procedure, and a method of appointment of an arbitrator or arbitrators, that method shall be followed instead of the method provided in subsection (b) of this section.

(f) This section shall apply to all written contracts executed on or after January 1, 1986.

37-16-3. Application to subcontracts.

When a contract described in 37-16-2 is in effect and any party thereto has entered into a subcontract to perform part of the work and/or furnish any materials in connection with the work described in the contract and the terms of the subcontract provide for arbitration of a dispute or claim concerning the performance or interpretation thereof, or the subcontract, expressly or by reference to the terms of the contract, provides that the parties to the subcontract shall comply with the arbitration provisions of the contract, the following shall apply when a request is made or an order of court is entered for arbitration either under the terms of the contract or subcontract.

(a) When arbitration under the contract may adversely affect the interest of a party thereto because of the effect of an award of the arbitrator or arbitrators upon the performance or interpretation of the terms of a subcontract to which he or she is also a party, he or she may require any other party or all other parties to the subcontract to become a party or parties to the arbitration.

(b) When a party to a subcontract makes a demand or an order of court is entered for arbitration under the terms of the subcontract which comply with the provision of this chapter, any party thereto who is also a party to the contract and whose rights under the contract may be adversely affected by the effect of an award of the arbitrator or arbitrators upon the performance or interpretation of the contract, may require any other party to the contract to become a party to the arbitration.

(c) When a party to a contract or to a subcontract is made a party to arbitration by virtue of the provisions of this section, he or she shall have all the rights of a party to arbitration as provided in this chapter except the appointment of an arbitrator. Provided, however, he or she may object to the arbitrators appointed by the parties in which event a single arbitrator shall be appointed as provided in 37-16-2 in the petition of either of the original parties to arbitration. The award of the arbitrator or arbitrators shall be valid and shall be binding on him or her to

the extent that it affects the performance or interpretation of the contract and/or subcontract to which he or she is a party. The award of the arbitrator or arbitrators may be enforced, modified, or vacated as this chapter provides an award made in an arbitration of a contract described in 37-16-2 may be enforced, modified, or vacated.

37-16-4. Stay of legal proceedings pending arbitration.

If any suit or proceedings be brought upon any issue referable to arbitration under contract in writing providing for arbitration, the court in which the suit is pending upon being satisfied that the issue involved in the suit or proceedings is referable to arbitration under the contract, shall on application of one of the parties, stay the trial of the action until arbitration has been held.

37-16-5. Jurisdiction of superior court to enforce arbitration provision and awards.

The entering into a contract in writing providing for arbitration shall be deemed a consent of all parties, including those enumerated in 37-16-2, thereto to the jurisdiction of the superior court of this state to enforce the arbitration provision and any award made pursuant to that provision. A party aggrieved by the failure, neglect, or refusal of another to perform under a contract providing for arbitration, may petition the superior court, or a judge thereof, for an order directing that arbitration proceed in the manner provided for in the contract. Five (5) days' notice in writing of the application shall be served upon the party in default. Service thereof shall be made in the manner specified in the contract, and if no manner specified therein, then in the manner provided by law for personal service of a summons, within or without the state, or substituted service of a summons, or upon satisfactory proof that the party aggrieved has been or will be unable with due diligence to make service in any of the foregoing manners, then notice shall be served in such manner as the court or judge may direct. A judge of the superior court shall hear the parties and upon being satisfied that there is no substantial issue as to the making of the contract or the failure to comply therewith, the court, or the judge thereof, hearing the application, shall make an order directing the parties to proceed to arbitration in accordance with the terms of the contract.

37-16-6. Trial upon evidence of substantial issue.

If evidentiary facts are set forth raising a substantial issue as to the making of the contract or the failure to comply therewith, the court, or the judge thereof, shall proceed immediately to the trial of the issues. Whenever an immediate trial is ordered, the order therefor shall provide that, if the court finds that a written contract providing for arbitration was made, and that there was a failure to comply therewith, the parties shall proceed with the arbitration in accordance with the terms of the contract and the order shall provide that if the court finds that there was no contract or failure to comply with the contract, then the proceeding shall be dismissed.

37-16-7. Method of appointing arbitrators or umpire.

If in the contract providing for arbitration, provision is made for a method of naming or appointing an arbitrator or arbitrators or an umpire, that method shall be followed, but if no method be provided therein, then the parties to the contract shall agree to the method of naming or appointing an arbitrator or arbitrators or an umpire and if the parties shall fail to agree, then the court or the judge thereof upon application of either of the parties after due notice to the other party shall appoint an arbitrator to hear the dispute.

37-16-8. Scheduling and notice of arbitration hearing - Adjournment.

Subject to the terms of the contract, if any are specified therein, the arbitrators selected as prescribed in this chapter must appoint a time and place for the hearing of the matters submitted to them, and must cause notice thereof to be given to each of the parties. They, or a majority of them, may adjourn the hearing from time to time upon the application of either party for good cause shown or upon their own motion, but not beyond the day fixed if a date in the contract, if any, for rendering their award, unless the time so fixed is extended by the written consent of the parties to the contract or their attorney, or the parties have continued with the arbitration without objection to such adjournment.

37-16-9. Power of court to direct prompt hearing.

The court shall have power to direct the arbitrators to proceed promptly with the hearing and determination of the dispute, claim, or matter in question.

37-16-10. Arbitrator's oath - Waiver.

Before hearing any testimony, arbitrators selected as prescribed in this chapter must be sworn, by an officer authorized by law to administer an oath, faithfully and fairly to hear and examine the claim, dispute, or matter in question and to make a just award according to the best of their understanding, unless the oath is waived by the

written consent of the parties to the contract or their attorneys or the parties have continued with the arbitration without objection to the failure of the arbitrators to take the oath.

37-16-11. Powers of arbitrators.

The arbitrator or arbitrators selected as prescribed in this chapter, may require any person to attend before them as a witness; and he or she and they have, and each of them has, the same powers with respect to all the proceedings before them which are conferred upon a board or a member of a board authorized by law to hear testimony. All the arbitrators selected as prescribed in this chapter must meet together and hear all the allegations and proofs of the parties; but an award by a majority of them is valid.

37-16-12. Fees.

In any proceeding under this chapter, unless the parties agree as to the arbitrator's or arbitrators' fees, such fees shall be fixed by the court or the judges thereof who shall require the payment equally by both parties of the arbitrators' fees.

37-16-13. Validity of awards.

An award shall be valid and enforceable according to its terms and under the provisions of this chapter, without previous adjudication of the existence of a contract to arbitrate, subject, nevertheless, to the provisions of this section:

- (a) A party who has participated in any of the proceedings before the arbitrator or arbitrators may object to the confirmation of the award only on one or more of the grounds hereinafter specified (provided that he did not continue with the arbitration with notice of the facts or defects upon which his objection is based) because of a failure to comply with 37-16-8 or with 37-16-10 or because of the improper manner of the selection of the arbitrators.
- (b) A party who has not participated in any of the proceedings had before the arbitrator or arbitrators and who has not made or been served with an application to compel arbitration under 37-16-5 may also put in issue the making of the contract or the failure to comply therewith, either by a motion for a stay of the arbitration or in opposition to the confirmation of the award. If a notice shall have been personally served upon such party of an intention to conduct the arbitration pursuant to the provisions of a contract specified in the notice, then the issues specified in this subdivision may be raised only by a motion for a stay of the arbitration, notice of which motion must be served within ten (10) days after the service of the notice of intention to arbitrate. The notice must state in substance that unless within ten (10) days after its service, the party served therewith shall serve a notice of motion to stay the arbitration, he or she shall thereafter be barred from putting in issue the making of the contract or the failure to comply therewith. The arbitration hearing shall be adjourned upon service of the notice pending the determination of the motion. Where the opposing party, either on a motion for a stay or in opposition to the confirmation of an award, sets forth evidentiary facts raising a substantial issue as to the making of the contract or the failure to comply therewith, an immediate trial of the same shall be had. In the event that the party is unsuccessful he or she may, nevertheless, participate in the arbitration if the same is still being carried on.

37-16-14. Arbitration under chapter deemed special proceeding - Jurisdiction of superior court.

Arbitration of a claim, dispute, or matter in question under a contract described in this chapter shall be deemed a special proceeding, of which the superior court for Providence County shall have jurisdiction.

37-16-15. Procedure for hearing of application to court.

Any application to the court, or a judge thereof, hereunder shall be made and heard in the manner provided by law for the making and hearing of motions, except as otherwise herein expressly provided.

37-16-16. Form of award.

To entitle the award to be enforced, as prescribed in this chapter, it must be in writing; and, within the time limited in the contract, if any, subscribed by the arbitrator or arbitrators making it and either filed in the office of the clerk of the court having jurisdiction as provided in 37-16-14 or delivered to one of the parties or his or her attorney.

37-16-17. Court order confirming award.

At any time within one year after the award is made, as prescribed in 37-16-16, any party to the contract by the terms of which arbitration was had, may apply to the court having jurisdiction as provided in 37-16-14 for an order confirming the award. Thereupon the court must grant the order unless the award is vacated, modified, or corrected, as prescribed in 37-16-18 and 37-16-19 or unless the award is unenforceable under the provisions of 37-16-13. Notice of the motion must be served upon the adverse party or parties or his or her or their attorneys, as prescribed by law for service of notice of a motion upon an attorney in an action in the same court.

37-16-18. Court order vacating award.

In any of the following cases, the court must make an order vacating the award, upon the application of any party to the controversy which was arbitrated

- (a) When the award was procured by fraud.
- (b) Where the arbitrator or arbitrators exceeded their powers, or so imperfectly executed them, that a mutual, final, and definite award upon the subject matter submitted was not made.
- (c) If there was no valid contract, and the objection has been raised under the conditions set forth in 37-16-13.

37-16-19. Rehearing after vacation of award.

Where an award is vacated, the court, in its discretion may direct a rehearing either before the same arbitrator or arbitrators or before a new arbitrator or arbitrators to be chosen in the manner provided in the contract for the selection of the original arbitrator or arbitrators or as provided for in 37-16-7 and any provision limiting the time in which the arbitrator or arbitrators may make a decision shall be deemed applicable to the new arbitration and to commence from the date of the court's order.

37-16-20. Court order modifying or correcting award.

In any of the following cases, the court must make an order modifying or correcting the award, upon the application of any party to the contract by the terms of which the arbitration was held.

- (a) Where there was an evident miscalculation of figures or an evident mistake in the description of any persons, thing, or property referred to in the award.
- (b) Where the arbitrator or arbitrators have awarded upon a matter not submitted to them, not affecting the merits of the decision upon the matter submitted.
- (c) Where the award is imperfect in a matter of form not affecting the merits of the controversy, and, if it had been a master's report the defect could have been amended or disregarded by the court.

37-16-21. Notice of motion to vacate, modify, or correct an award.

Notice of a motion to vacate, modify, or correct an award must be served upon all adverse parties, or their attorneys, within sixty (60) days after the award is filed or delivered, as prescribed by law for service of notice of a motion upon an attorney in an action; except that in opposition to a motion to confirm an award, any of the grounds specified in 37-16-18 may be set up. For the purpose of the motion, any judge who might make an order, to stay the proceedings in an action brought in the same court may make an order, to be served with the notice of motion, staying the proceedings of an adverse party or parties to enforce the award.

37-16-22. Entry of judgment - Costs.

Upon the granting of an order confirming, modifying, or correcting an award, judgment may be entered in conformity therewith, except as is otherwise prescribed in this chapter. Costs of the application and of the proceedings subsequent thereto, not exceeding twenty-five dollars (\$25.00) and disbursements, may be awarded by the court in its discretion. If awarded, the amount thereof must be included in the judgment.

37-16-23. Filing of papers after judgment.

(a) Immediately after entering judgment, the clerk must attach together and file the following papers:

- (1) The contract, and each written extension of the time, if any, within which to make the award.
- (2) The award.
- (3) Each notice, affidavit or other paper used upon an application to confirm, modify, or correct the award, and a copy of each order of the court upon the application.
- (4) A copy of the judgment.

(b) The judgment may be docketed as if it was rendered in an action.

37-16-24. Effect of judgment.

The judgment so entered has the same force and effect, in all respects as, and is subject to all the provisions of law relating to a judgment in an action. The judgment may be enforced as if it had been rendered in an action in the court in which it is entered.

37-16-25. Appeals.

An appeal may be taken from an order made in a proceeding under this chapter, or from a judgment entered upon an award. The proceedings upon the appeal, including the judgment thereupon and the enforcement of the judgment, are governed by the provisions of statute and rule regulating appeal in actions as far as they are applicable.

37-16-26. Satisfaction of award.

- (a) An award which requires the payment of a sum of money by a city, town, or the state or any body described in 37-16-2 created or organized by or through the authority of any of them, shall be satisfied to the extent of payment of that sum by payment thereof to the party to whom the award was made by the treasurer or officer exercising the duties of a treasurer thereof from its general funds.
- (b) An award which requires the payment of a sum of money to a city, a town, or the state or any body described in 37-16-2 created or organized by or through the authority of any of them shall be satisfied to the extent of payment of that sum by payment thereof to its treasurer or officer exercising the duties of a treasurer thereof who shall deposit the same in its general funds.

37-16-27. Application to sureties.

- (a) If a contractor principal on a bond furnished to guarantee performance or payment on a construction contract and the claimant are parties to a written contract with a provision to submit to arbitration any controversy thereafter arising under the contract, or subject to arbitration as provided in 37-16-2(b), the arbitration provisions shall apply to the surety for all disputes involving questions of the claimant's right of recovery against the surety. Either the claimant, the contractor principal, or surety may demand arbitration in accordance with the written contract or as provided in 37-16-2(b) if applicable in one arbitration proceeding, provided that the provisions of 37-16-3 shall be applicable to any such demand for arbitration. The arbitration award shall decide all controversies subject to arbitration between the claimant, on the one hand, and the contractor principal and surety on the other hand, including all questions involving liability of the contractor principal and surety on the bond, but a claimant must file suit for recovery against the surety within the time limits set forth in 37-12-2 and 37-12-5. The arbitration shall be in accordance with this chapter and the court shall enter judgment thereon as provided therein.
- (b) The arbitrator or arbitrators, if more than one, shall make findings of fact as to the compliance with the requirements for recovery against the surety, and those findings of fact shall be a part of the award binding on all parties to the arbitration.

TITLE 45

CHAPTER 55 AWARD OF MUNICIPAL CONTRACTS

SECTIONS

- 45-55-1 Legislative findings
- 45-55-2. Method of source selection
- 45-55-3. Purchasing agent - Appointment - Duties.
- 45-55-4. Definitions.
- 45-55-5. Competitive sealed bidding.
- 45-55-5.1. Business exempt.
- 45-55-5.2. Town of North Smithfield - Exemption.
- 45-55-6. Competitive negotiation.
- 45-55-7. Negotiations after unsuccessful competitive sealed bidding
- 45-55-8. Sole source procurement and emergency procurements.
- 45-55-8.1 Qualification based selection of architects and engineers.
- 45-55-9. Small purchases.
- 45-55-10. Cancellation of invitation for bids and requests for proposals.
- 45-55-11. Responsibilities of bidders and offerors
- 45-55-12. Prequalification of contractors - General.
- 45-55-13. Exclusion of state mandated costs.
- 45-55-13.1. Exclusion of multi-cities or towns insurance corporations and cooperative risk management programs.
- 45-55-13.2. Exclusion of multi-cities or towns energy aggregation programs.
- 45-55-13.3. Exclusion of multi-school district combined purchasing consortia
- 45-55-14. Staff consultants.
- 45-55-15. Severability.
- 45-55-16 Prohibition against the use of lead based paints.
- 44-55-17 Penalties

45-55-1. Legislative findings.

It is hereby declared that a need exists to establish a uniform system for the award of contracts by municipalities, utilizing open cooperative bids.

45-55-2. Method of source selection.

Except as otherwise authorized by law, all municipal contracts shall be awarded by:

- (1) Competitive sealed bidding, pursuant to 45-55-5;
- (2) Competitive negotiations, pursuant to 45-55-6;
- (3) Non-competitive negotiations, pursuant to 45-55-7 and 45-55-8;
- (4) Small purchase procedures, pursuant to 45-55-9.
- (5) Qualification based selection (QBS) process for architects/engineers pursuant to 45-55-8.1

45-55-3. Purchasing agent - Appointment - Duties.

Within each city or town or quasi public agency there shall be designated a person or persons to act as purchasing officer to exercise the powers and duties as set forth in this chapter.

45-55-4. Definitions.

The words defined in this section have the following meanings whenever they appear in this chapter, unless the context in which they are used clearly requires a different meaning or a different definition is prescribed for a particular section, group of sections or provision.

- (1) "Business" means any corporation, partnership, individual, sole proprietorship, joint stock company, joint venture, or any other legal entity through which business is conducted.
- (2) "Change order" means a written order signed by the purchasing agent, or contractor directing or allowing the contractor to make changes which the changes clause of the contract authorizes the purchasing agent or contractor to order without the consent of the contractor or purchasing agent.
- (3) "Construction" means the process of building, altering, repairing, improving, or demolishing any public structures or building, or other public improvements of any kind to any public real property. It does not include the routine maintenance or repair of existing structures, buildings, or real property performed by salaried employees of the municipality in the usual course of their job.
- (4) "Contract" means all types of agreements, including grants and orders, for the purchase or disposal of supplies, services, construction, or any other item. It includes awards; contracts of a fixed-price, cost, cost-plus-a-fixed-fee, or incentive type; contracts providing for the issuance of job or task orders; leases; letter contracts, purchase orders, and construction management contracts. It also includes supplemental agreements with respect to any of the preceding. "Contract" does not include labor contracts with employees of the municipality.
- (5) "Contract modification" means any written alteration in the specifications, delivery point, rate of delivery, contract period, price, quantity, or other contract provisions of any existing contract, whether accomplished by unilateral action in accordance with a contract provision, or by mutual action of the parties to the contract. It includes bilateral actions, as supplemental agreements, and unilateral actions, as change orders, administrative changes, notices of termination, and notices of the exercise of a contract option.
- (6) "Contractor" means any person having a contract with a municipality.
- (8) "Data" means recorded information, regardless of form or characteristic.
- (8) "Designee" means a duly authorized representative of a person holding a superior position.
- (9) "Employee" means an individual drawing a salary from a municipality, whether elected or not, and any non-salaried individual performing personal services for any municipality.
- (10) "May" means permissive.
- (11) "Municipality" means the individual cities and towns of the state of Rhode Island.
- (12) "Negotiation" means contracting by either of the methods described in §§ 45-55-6, 45-55-7, and 45-55-8.
- (13) "Person" means any business, individual, organization, or group of individuals.
- (14) "Procurement" means the purchasing, buying, renting, leasing, or otherwise obtaining of any supplies, services, or construction. It also includes all functions that pertain to the obtaining of any supply, service, or construction item, including description of requirements, selection and solicitation of sources, preparation and award of contract, and all phases of contract administration.
- (15) "Purchasing officer" means the person designated in each municipality or quasi public agency pursuant to section 45-55-3.
- (16) "Regulations" means rules and regulations adopted by the individual cities or towns, concerning the implementation of the provisions of this chapter.

(17) "Services" means the rendering, by a contractor, of its time and effort rather than the furnishing of a specific end product, other than reports which are merely incidental to the required performance of services. "Services" does not include labor contracts with employees of governmental agencies.

(18) "Shall" means imperative.

(19) "Supplemental agreement" means any contract modification which is accomplished by the mutual action of the parties.

(20) "Supplies" means all property, including, but not limited to, leases of real property, printing and insurance, except land or permanent interest in land.

45-55-5. Competitive sealed bidding.

(a) Contracts exceeding the amount provided by 45-55-9 shall be awarded by competitive bidding unless they are professional engineering/architectural services pursuant to 45-55-8.1 and it is determined in writing that this method is not practicable. Factors to be considered in determining whether competitive sealed bidding is practicable shall include whether:

- (1) Specifications can be prepared that permit award on the basis of either the lowest qualified bid price or the lowest qualified evaluated bid price; and
 - (2) The available sources, the time and place of performance, and other relevant circumstances as are appropriate for the use of competitive sealed bidding.
- (b) The invitation for bids shall state whether award shall be made on the basis of the lowest bid price or the lowest evaluated or responsive bid price. If the latter basis is used, the objective measurable criteria to be utilized shall be stated in the invitation for bids, if available.
- (c) Adequate public notice of the invitation for bids shall be given a sufficient time prior to the date stated in the notice for the opening of bids. Notice may include publication in a newspaper of general circulation in the state as determined by the purchasing officer for the municipality not less than seven (7) days nor more than twenty-one (21) days before the date set for opening of the bids. The purchasing officer may make a written determination that the twenty-one (21) day limitation needs to be waived. The written determination shall state the reason why the twenty-one (21) day limitation is being waived and shall state the number of days, giving a minimum and maximum, before the date set for the opening of bids when public notice is to be given.
- (4) Bids shall be opened publicly in full view of the public at the time and place designated in the invitation for bids. Each bid, together with the name of the bidder, shall be recorded and an abstract made available for public inspection. Subsequent to the awarding of the bid, all documents pertinent to the awarding of the bid shall be made available and open to public inspection and retained in the bid file.
- (5) The contract shall be awarded with reasonable promptness by written notice to the responsive and responsible bidder whose bid is either the lowest bid price, or lowest evaluated or responsive bid price.
- (6) Correction or withdrawal of bids may be allowed only to the extent permitted by regulations issued by the purchasing officer.

45-55-5.1. Business exempt.

The North Kingstown Bus Contractors Association and the Scituate School Bus Owners Club shall be exempt from the provisions of this chapter.

45-55-5.2. Town of North Smithfield - Exemption.

The town of North Smithfield is exempt from the provisions of this chapter with regard to the contracting for fire and rescue services with the Primrose Volunteer Fire Department and/or North Smithfield Fire Department and/or their respective successors and assigns.

45-55-6. Competitive negotiation.

- (a) When, under regulations adopted by the city or town council, the purchasing agent determines in writing that the use of competitive sealed bidding is not practicable, and except as provided in 45-55-8, 45-55-9, and 45-55-10 a contract may be awarded by competitive negotiation.
- (b) Adequate public notice of the request for proposals shall be given in the same manner as provided in 45-55-5(c).
- (c) Contracts may be competitively negotiated when it is determined, in writing, by the purchasing agent that the bid prices received by competitive sealed bidding either are unreasonable as to all or part of the requirements, or were not independently reached in open competition, and for which:
 - (1) Each competitive bidder has been notified of the intention to negotiate and is given reasonable opportunity to negotiate; and
 - (2) The negotiated price is lower than the lowest rejected bid by any competitive bidder; and
 - (3) The negotiated price is the lowest negotiated price offered by a competitive offeror.
- (d) The request for proposals shall indicate the relative importance of price and other evaluation factors.
- (e) Award shall be made to the responsible offeror whose proposal is determined in writing to be the most advantageous to the municipality taking into consideration price and the evaluation factors set forth in the request for proposals.
- (f) Written or oral discussions shall be conducted with all responsible offerors who submit proposals determined, in writing, to be reasonably susceptible of being selected for award. Discussions shall not disclose any information derived from proposals submitted by competing offerors. Discussions need not be conducted:
 - (1) With respect to prices, where such prices are fixed by law or regulation, except that consideration shall be given to competitive terms and conditions; or
 - (2) Where time of delivery or performance will not permit discussions; or
 - (3) Where it can be clearly demonstrated and documented from the existence of adequate competition or accurate prior cost experience with the particular supply, service, or construction item, that acceptance of an initial offer without discussion would result in fair and reasonable prices, and the request for proposals notifies all offerors of the possibility that award may be made on the basis of the initial offers.

45-55-7. Negotiations after unsuccessful competitive sealed bidding.

- (a) In the event that all bids submitted pursuant to competitive sealed bidding under 45-55-5 result in bid prices in excess of the funds available for the purchase, and the purchasing officer determines in writing:
 - (1) That there are no additional funds available from any source so as to permit an award to the lowest responsive and responsible bidder, and
 - (2) The best interest of the municipality will not permit the delay attendant to a re-solicitation under revised specifications, or for revised quantities, under competitive sealed bidding as provided in 45-55-5, then a negotiated award may be made as stated in subsection (b) or (c) of this section.
- (b) Where there is more than one bidder, competitive negotiations pursuant to 45-55-6, shall be conducted with the three (3) (two (2) if there are only two (2)) bidders determined in writing, to be the lowest responsive and responsible bidders to the competitive sealed bid invitation. Competitive negotiations shall be conducted under the following restrictions:
 - (1) If discussions pertaining to the revision of the specifications or quantities are held with any potential offeror, all other potential offerors shall be afforded an opportunity to take part in the discussions; or

(2) A request for proposals, based upon revised specifications or quantities, shall be issued as promptly as possible, shall provide for an expeditious response to the revised requirements, and shall be awarded upon the basis of the lowest bid price, or lowest evaluated bid price submitted by any responsive and responsible offeror.

(c) When after competitive sealed bidding, it is determined in writing, that there is only one responsive and responsible bidder, a noncompetitive negotiated award may be made with such bidder in accordance with 45-55-8.

45-55-8. Sole source procurement and emergency procurements.

(a) A contract may be awarded for a supply, service, or construction item without competition when, under published regulations, the purchasing officer determines, in writing, that there is only one source for the required supply, service, or construction item.

(b) Notwithstanding any other provision of this chapter, the purchasing agent may make or authorize others to make emergency procurements when there exists a threat to public health, welfare, or safety under emergency conditions as defined in regulations or where the procurement will be in the best interest of the city as established by properly promulgated rules and regulations; provided, that such emergency procurements shall be made with such competition as is practicable under the circumstances. A written determination of the basis for the emergency, and for the selection of the particular contractor, shall be included in the contract file.

45-55-8.1. Qualification based selection of architects and engineers.

When the purchasing agent determines that the city or town needs the services of a professional architect or engineer, the purchasing agent shall follow the qualification based selection process for the procurement of architectural and engineering consulting services.

45-55-9. Small purchases.

Procurements, not to exceed an aggregate amount of ten thousand dollars (\$10,000) for construction and five thousand dollars (\$5,000) for all other purchases may be made in accordance with small purchase regulations promulgated by the municipality. These amounts shall be increased or decreased annually hereafter at the same rate as the Boston Regional Consumer Price Index. Procurement requirements shall not be artificially divided so as to constitute a small purchase under this section. A municipality may further reduce the aggregate purchase amount, as provided for in this section by ordinance.

45-55-10. Cancellation of invitation for bids and requests for proposals.

An invitation for bids, a request for proposals, or other solicitation may be canceled, or all bids or proposals rejected, if it is determined, in writing, that such action if taken is not in the best interest of the municipality and approved by the chief purchasing officer.

45-55-11. Responsibilities of bidders and offerors.

(1) A written determination of responsibility of a bidder or offeror shall be made and it shall be made in accordance with regulations issued by the municipality.

A reasonable inquiry to determine the responsibility of a bidder or offeror may be conducted. The failure of a bidder or offeror to promptly supply information in connection with a reasonable inquiry may be grounds for a determination of non-responsibility with respect to a bidder or offeror.

(2) Except as otherwise provided, by law, information furnished by a bidder or offeror pursuant to this section may not be disclosed outside of the purchasing department administering the contract without prior written consent of the bidder or offeror.

45-55-12. Prequalification of contractors - General.

The municipality may provide for prequalification of suppliers as responsible prospective contractors for particular types of supplies, services, and construction. Municipalities which choose to provide for prequalification of suppliers shall adopt regulations for prequalification in the same manner provided for in the adoption of ordinances in the manner provided for in the legislative or home rule charter of the municipality. Solicitation mailing lists of

potential contractors of supplies, services, and construction shall include but need not be limited to prequalified contractors. Prequalification shall not foreclose a written determination:

- (1) Between the time of the bid opening or receipt of offers and the making of an award, that a prequalified supplier is not responsible; or
- (2) That a supplier who is not prequalified at the time of bid opening or receipt of offers is responsible.

45-55-13. Exclusion of state mandated costs.

The provisions of 45-13-7 through 45-13-10 do not apply to this section.

45-55-13.1. Exclusion of multi-cities or towns insurance corporations and cooperative risk management programs.

The provisions of this chapter shall not apply to entities organized pursuant to section 45-5-20.1. Those entities are exempt from all of the provisions of this chapter.

45-55-13.2. Exclusion of multi-cities or towns energy aggregation programs.

The provisions of this chapter do not apply to entities organized for the purpose of negotiating the purchase of electric power pursuant to § 39-3-1.1, or energy or energy related services. Those entities are exempt from all provisions of this chapter.

45-55-13.3. Exclusion of multi-school district combined purchasing consortia.

The provisions of this chapter do not apply to purchases and contracts entered into by those consortia established pursuant to § 16-2-9.2, and such entities shall be exempt from all provisions of this chapter.

45-55-14. Staff consultants.

The procurement of the service of an attorney, physician or dentist by a municipality, is exempt from the provisions of this chapter.

45-55-15. Severability.

If any one or more sections, clauses, sentences or parts of this chapter are for any reason be adjudged unconstitutional or otherwise invalid in any court, that judgment shall not affect, impair or invalidate the remaining provisions of this chapter but shall be confined in its operation to the specific provisions so held unconstitutional or invalid and the inapplicability or invalidity of any section, clause or provisions of this chapter in any one or more instances or circumstances shall not be taken to affect or prejudice in any way its applicability or validity in any other instance.

45-55-16. Prohibition against the use of lead based paints.

When purchasing paint products or contracting or subcontracting for painting, construction, improvement, completion, or repair of any public buildings, public road, public bridge, or public construction, all municipalities, as defined by 45-55-4(11), shall be prohibited from the use of lead based paint.

45-55-17. Penalties.

Any person who knowingly and intentionally violates any provision of this chapter shall be subject to a misdemeanor, punishable by a fine of not more than five hundred dollars (\$500), or by imprisonment for not more than one year, or both.