



**BOARD OF CONTRACT AND SUPPLY
CITY OF PROVIDENCE, RHODE ISLAND**

REQUEST FOR PROPOSALS

Item Description: Re-Bid Education Center & Events Pavilion at the Roger Williams Park Zoo

Procurement/MinuteTraq #: 44958

Date to be opened: 6/3/2024

Issuing Department: Department of Parks

QUESTIONS

- Please direct questions related to the bidding process, how to fill out forms, and how to submit a bid (Pages 1-8) to the Purchasing Department.
 - Email: purchasing@providenceri.gov
 - Please use the subject line “**Solicitation Question**”
- Please direct questions relative to the Minority and Women’s Business Enterprise Program and the corresponding forms (Pages 11-12) to the MBE/WBE Outreach Director for the City of Providence, Grace Diaz
 - Phone: (401) 680-5766
 - Email: gdiaz@providenceri.gov
 - Please use subject line “**MBE WBE Forms**”
- Please direct questions relative to the specifications outlined (beginning on page 14) to the issuing department’s subject matter expert:
 - Email: purchasing@providenceri.gov
 - Please use the subject line “**Solicitation Question**”
- **All questions must be submitted no later than 1:00 P.M. on 5/27/24**

Pre-bid Conference

There will be a Non-Mandatory Pre-Bid Conference

Date of Pre-Bid Conference: 5/20/2024

Time: 10:00 A.M.

Other details: Meet at GATE 3 of Roger Williams Park Zoo, 1000 Elmwood Ave., Providence, RI 02905



**BOARD OF CONTRACT AND SUPPLY
CITY OF PROVIDENCE, RHODE ISLAND**

INSTRUCTIONS FOR SUBMISSION

Bids may be submitted up to **2:15 P.M.** on the above meeting date at the **Department of the City Clerk, Room 311, City Hall, 25 Dorrance Street, Providence.** At 2:15 P.M. all bids will be publicly opened and read at the Board of Contract Meeting in Conference Room 305, on the 3rd floor of City Hall.

- Bidders must submit **2 copies** of their bid in sealed envelopes or packages labeled with the caption **“Re-Bid Education Center & Events Pavilion at the Roger Williams Park Zoo”** and the **City Department to which the solicitation and bid are related and must include the company name and address on the envelope as well.** (On page 1).
- If required by the Department, please keep the original bid bond and check in only one of the envelopes.
- Communications to the Board of Contract and Supply that are not competitive sealed bids (i.e. product information/samples) should have **“NOT A BID”** written on the envelope or wrapper.
- Only use form versions and templates included in this solicitation. If you have an old version of a form **do not recycle it for use in this bid.**
- The bid envelope and information relative to the bid must be addressed to:

**Board of Contract and Supply
Department of the City Clerk – City Hall, Room 311
25 Dorrance Street
Providence, RI 02903**

****PLEASE NOTE:** This bid may include details regarding information that you will need to provide (such as proof of licenses) to the issuing department before the formalization of an award.

This information is NOT requested to be provided in your initial bid by design.

All bids submitted to the City Clerk become public record. Failure to follow instructions could result in information considered private being posted to the city’s Open Meetings Portal and made available as a public record. The City has made a conscious effort to avoid the posting of sensitive information on the City’s Open Meetings Portal, by requesting that such sensitive information be submitted to the issuing department only at their request.



**BOARD OF CONTRACT AND SUPPLY
CITY OF PROVIDENCE, RHODE ISLAND**

BID PACKAGE CHECKLIST

Digital forms are available in the City of Providence Purchasing Department Office or online at <http://www.providenceri.gov/purchasing/how-to-submit-a-bid/>

The bid package **MUST** include the following, in this order:

- Bid Form 1: Bidder's Blank as the cover page/ 1st page (*see page 6 of this document*)
- Bid Form 2: Certification of Bidder as 2nd page (*see page 7 of this document*)
- Bid Form 3: Certificate Regarding Public Records (*see page 8 of this document*)
- Bid Form 4: Affidavit of City Vendor (*see pages 9 and 10 of this document*)
- Forms from the Minority and Women Business Enterprise Program: Based on Bidder Category. *See forms and instructions enclosed (see pages 11-12 of this document) or on:*
<https://www.providenceri.gov/purchasing/minority-women-owned-business-mbewbe-procurement-program/>
- Supplemental Bid Form (*see pages 14-15 of this document*)

***Please note: MBE/WBE forms must be completed for EVERY bid submitted and must be inclusive of ALL required signatures. Forms without all required signatures will be considered incomplete.**

- Bidder's Proposal/Packet: Formal response to the specifications outlined in this RFP, including pricing information and details related to the good(s) or service(s) being provided. Please be mindful of formatting responses as requested to ensure clarity.
- Financial Assurance, *if requested* (as indicated on page 5 of this document under "Bid Terms")

All of the above listed documents are REQUIRED. (With the exception of financial assurances, which are only required if specified on page 5.)

*****Failure to meet specified deadlines, follow specific submission instructions, or enclose all required documents with all applicable signatures will result in disqualification, or in an inability to appropriately evaluate bids.**



**BOARD OF CONTRACT AND SUPPLY
CITY OF PROVIDENCE, RHODE ISLAND**

NOTICE TO VENDORS

1. The Board of Contract and Supply will make the award to the lowest qualified and responsible bidder.
2. In determining the lowest responsible bidder, cash discounts based on preferable payment terms will not be considered.
3. Where prices are the same, the Board of Contract and Supply reserves the right to award to one bidder, or to split the award.
4. No proposal will be accepted if the bid is made in collusion with any other bidder.
5. Bids may be submitted on an “equal in quality” basis. The City reserves the right to decide equality. Bidders must indicate brand or the make being offered and submit detailed specifications if other than brand requested.
6. A bidder who is an out-of-state corporation shall qualify or register to transact business in this State, in accordance with the Rhode Island Business Corporation Act, RIGL Sec. 7-1.2-1401, et seq.
7. The Board of Contract and Supply reserves the right to reject any and all bids.
8. Competing bids may be viewed in person at the Department of the City Clerk, City Hall, Providence, immediately upon the conclusion of the formal Board of Contract and Supply meeting during which the bids were unsealed/opened. Bids may also be accessed electronically on the internet via the City’s [Open Meetings Portal](#).
9. As the City of Providence is exempt from the payment of Federal Excise Taxes and Rhode Island Sales Tax, prices quoted are not to include these taxes.
10. In case of error in the extension of prices quoted, the unit price will govern.
11. The contractor will **NOT** be permitted to: a) assign or underlet the contract, or b) assign either legally or equitably any monies or any claim thereto without the previous written consent of the City Purchasing Director.
12. Delivery dates must be shown in the bid. If no delivery date is specified, it will be assumed that an immediate delivery from stock will be made.
13. A certificate of insurance will normally be required of a successful vendor.
14. For many contracts involving construction, alteration and/or repair work, State law provisions concerning payment of prevailing wage rates apply ([RIGL Sec. 37-13-1 et seq.](#))
15. No goods should be delivered, or work started without a Purchase Order.
16. **Submit 2 copies of the bid to the City Clerk, unless the specification section of this document indicates otherwise.**
17. Bidder must certify that it does not unlawfully discriminate on the basis of race, color, national origin, gender, gender identity or expression, sexual orientation and/or religion in its business and hiring practices and that all of its employees are lawfully employed under all applicable federal, state and local laws, rules and regulations. (See Bid Form 2.)



**BOARD OF CONTRACT AND SUPPLY
CITY OF PROVIDENCE, RHODE ISLAND**

BID TERMS

1. Financial assurances may be required in order to be a successful bidder for Commodity or Construction and Service contracts. If either of the first two checkboxes below is checked, the specified assurance must accompany a bid, or the bid will not be considered by the Board of Contract and Supply. The third checkbox indicates the lowest responsible bidder will be contacted and required to post a bond to be awarded the contract.
 - a) A certified check for \$_____ must be deposited with the City Clerk as a guarantee that the Contract will be signed and delivered by the bidder.
 - b) A bid bond in the amount of **5 per centum (%)** of the proposed total price, must be deposited with the City Clerk as a guarantee that the contract will be signed and delivered by the bidder; and the amount of such bid bond shall be retained for the use of the City as liquidated damages in case of default. Any person signing a bid bond as an attorney-in-fact shall include with the bid bond an original, or a photocopy or facsimile of an original, power of attorney.
 - c) A performance and payment bond with a satisfactory surety company will be posted by the bidder in a sum equal to one hundred per centum (100%) of the awarded contract.
 - d) No financial assurance is necessary for this item.
2. Awards will be made within **ninety (90) days of bid opening**. All bid prices will be considered firm, unless qualified otherwise. Requests for price increases will not be honored.
3. Failure to deliver within the time quoted or failure to meet specifications may result in default in accordance with the general specifications. It is agreed that deliveries and/or completion are subject to strikes, lockouts, accidents, and Acts of God.

The following entry applies only for COMMODITY BID TERMS:

4. Payment for partial delivery will not be allowed except when provided for in blanket or term contracts.

The following entries apply only for CONSTRUCTION AND SERVICE BID TERMS:

5. Only one shipping charge will be applied in the event of partial deliveries for blanket or term contracts.
6. Prior to commencing performance under the contract, the successful bidder shall attest to compliance with the provisions of the Rhode Island Worker's Compensation Act, [RIGL 28-29-1, et seq.](#) If exempt from compliance, the successful bidder shall submit a sworn Affidavit by a corporate officer to that effect, which shall accompany the signed contract.
7. Prior to commencing performance under the contract, the successful bidder shall, submit a certificate of insurance, in a form and in an amount satisfactory to the City.



**BOARD OF CONTRACT AND SUPPLY
CITY OF PROVIDENCE, RHODE ISLAND**

BID FORM 1: Bidders Blank

1. Bids must meet the attached specifications. Any exceptions or modifications must be noted and fully explained.
2. Bidder's responses must be in ink or typewritten, and all blanks on the bid form should be completed.
3. The price or prices proposed should be stated both in **WRITING** and in **FIGURES**, and any proposal not so stated may be rejected. **Contracts exceeding twelve months must specify annual costs for each year.**
4. Bids **SHOULD BE TOTALED** so that the final cost is clearly stated (unless submitting a unit price bid), however **each item should be priced individually**. Do not group items. Awards may be made on the basis of *total* bid or by *individual items*.
5. All bids **MUST BE SIGNED IN INK.**

Name of Bidder (Firm or Individual): _____

Contact Name: _____

Business Address: _____

Business Phone #: _____

Contact Email Address: _____

Agrees to bid on (Write the "Item Description" here): _____

If the bidder's company is based in a state other than Rhode Island, list name and contact information for a local agent for service of process that *is located within Rhode Island* _____

Delivery Date (if applicable): _____

Name of Surety Company (if applicable): _____

Total Amount in Writing*: _____

Total Amount in Figures*: _____

****If you are submitting a unit price bid, please insert "Unit Price Bid"***

Use additional pages if necessary for additional bidding details.

Signature of Representation

Title



**BOARD OF CONTRACT AND SUPPLY
CITY OF PROVIDENCE, RHODE ISLAND**

BID FORM 2: Certification of Bidder
(Non-Discrimination/Hiring)

Upon behalf of _____ (Firm or Individual Bidding),

I, _____ (Name of Person Making Certification),

being its _____ (Title or "Self"), hereby certify that:

1. Bidder does not unlawfully discriminate on the basis of race, color, national origin, gender, sexual orientation and/or religion in its business and hiring practices.
2. All of Bidder's employees have been hired in compliance with all applicable federal, state and local laws, rules and regulations.

I affirm by signing below that I am duly authorized on behalf of Bidder, on
this _____ day of _____, 20_____.

Signature of Representation

Printed Name



**BOARD OF CONTRACT AND SUPPLY
CITY OF PROVIDENCE, RHODE ISLAND**

BID FORM 3: Certificate Regarding Public Records

Upon behalf of _____ (Firm or Individual Bidding),

I, _____ (Name of Person Making Certification),

being its _____ (Title or "Self"), hereby certify an

understanding that:

1. All bids submitted in response to Requests for Proposals (RFP's) and Requests for Qualification (RFQ's), documents contained within, and the details outlined on those documents become public record upon receipt by the City Clerk's office and opening at the corresponding Board of Contract and Supply (BOCS) meeting.
2. The Purchasing Department and the issuing department for this RFP/RFQ have made a conscious effort to request that sensitive/personal information be submitted directly to the issuing department and only at request if verification of specific details is critical the evaluation of a vendor's bid.
3. The requested supplemental information may be crucial to evaluating bids. Failure to provide such details may result in disqualification, or an inability to appropriately evaluate bids.
4. If sensitive information that has not been requested is enclosed or if a bidder opts to enclose the defined supplemental information prior to the issuing department's request in the bidding packet submitted to the City Clerk, the City of Providence has no obligation to redact those details and bears no liability associated with the information becoming public record.
5. The City of Providence observes a public and transparent bidding process. Information required in the bidding packet may not be submitted directly to the issuing department at the discretion of the bidder in order to protect other information, such as pricing terms, from becoming public. Bidders who make such an attempt will be disqualified.

I affirm by signing below that I am duly authorized on behalf of Bidder, on

this _____ day of _____ 20 _____.

Signature of Representation

Printed Name



**BOARD OF CONTRACT AND SUPPLY
CITY OF PROVIDENCE, RHODE ISLAND**

BID FORM 4: Affidavit of City Vendor

Per our Code of Ordinances [Sec. 21.-28.1 \(e\)](#), this form applies to a) the business, b) any political action committee whose name includes the name of the business, c) all persons holding ten (10) percent or greater equity interest or five thousand dollars (\$5,000.00) or greater cash value interest in the business at any time during the reporting period, d) all executive officers of the business entity, e) any spouse or dependent child of any individual identified in a) though d) above.

Executive officers who are not residents of the state of Rhode Island are exempted from this requirement.

Per [R.I.G.L. § 36-14-2](#), “Business” means a sole proprietorship, partnership, firm, corporation, holding company, joint stock company, receivership, trust, or any other entity recognized in law through which business for profit or not for profit is conducted.

Name of the person making this affidavit: _____

Position in the “Business” _____

Name of Entity _____

Address: _____

Phone number: _____

The number of persons or entities in your entity that are required to report under [Sec. 21.-28.1 \(e\)](#): _____

Read the following paragraph and answer one of the options:

Within the 12 month period preceding the date of this bid submission with the City of Providence, or with respect to the contracts that are not in writing within the 12 month period preceding the date of notification that the contract has reached the \$100,000 threshold, have you made campaign contributions within a calendar year to (please list all persons or entities required under [Sec. 21.-28.1 \(e\)](#)).

a. Members of the Providence City Council? Yes No

- If Yes, please complete the following:

Recipient(s) of the Contribution:

Contribution Date(s):

Contribution Amount(s):

b. Candidates for election or reelection to the Providence City Council? Yes No

- If Yes, please complete the following:

Recipient(s) of the Contribution:

Contribution Date(s):

Contribution Amount(s):



**BOARD OF CONTRACT AND SUPPLY
CITY OF PROVIDENCE, RHODE ISLAND**

c. The Mayor of Providence? Yes No

- If Yes, please complete the following:

Recipient(s) of the Contribution:

Contribution Date(s):

Contribution Amount(s):

d. Candidates for election or reelection to the office of Mayor of Providence? Yes No

- If Yes, please complete the following:

Recipient(s) of the Contribution:

Contribution Date(s):

Contribution Amount(s):

Signed under the pains and penalties of perjury.

Position



**BOARD OF CONTRACT AND SUPPLY
CITY OF PROVIDENCE, RHODE ISLAND**

MBE/WBE Participation Plan

Please complete separate forms for each MBE/WBE subcontractor/supplier to be utilized on the solicitation.

Bidder's Name:					
Bidder's Address:					
Point of Contact:					
Telephone:					
Email:					
Procurement #:					
Project Name:					
Which one of the following describes your business' status in terms of Minority and/or Woman Owned Business Enterprise certification with the State of Rhode Island? (Check all that apply).	<input type="checkbox"/> MBE	<input type="checkbox"/> WBE	<input type="checkbox"/> Neither MBE nor WBE		
<p>This form is intended to capture commitments between the prime contractor/vendor and MBE/WBE subcontractors and suppliers, including a description of the work to be performed and the percentage of the work as submitted to the prime contractor/vendor. Please note that all MBE/WBE subcontractors/suppliers must be certified by the Office of Diversity, Equity and Opportunity at the time of bid. The MBE/WBE Directory can be found here. Please visit, the City's MBE/WBE page for details of the program (e.g. instructions and requirements).</p> <ul style="list-style-type: none"> Nonprofit organizations are not required to complete the rest of this form. Construction projects unable to identify subcontractors prior to bid submission (e.g. Design Build) are required to provide updates to the MBE/WBE Outreach Office 					
Name of Subcontractor/Supplier:					
Type of RI Certification:	<input type="checkbox"/> MBE	<input type="checkbox"/> WBE	<input type="checkbox"/> Neither		
Address:					
Point of Contact:					
Telephone:					
Email:					
Detailed Description of Work to Be Performed by Subcontractor or Materials to be Supplied by Supplier Per the Scope of Work provided in the RFP					
Total Contract Value (\$):		Subcontract Value (\$):		Participation Rate (%):	
Anticipated Date of Performance:					
I certify under penalty of perjury that the forgoing statements are true and correct.					
Prime Contractor/Vendor Signature	Title			Date	
Subcontractor/Supplier Signature	Title			Date	

***If you did not meet the 20% MBE/WBE combined participation goal, submit a Waiver Request Form.**



**BOARD OF CONTRACT AND SUPPLY
CITY OF PROVIDENCE, RHODE ISLAND**

MBE/WBE Waiver Request Form

**Fill out this form only if you did not meet the 20% MBE/WBE participation goal.
State-certified MBE or WBE Prime Bidders are NOT REQUIRED to fill out this form.**

Submit this form to the City of Providence MBE/WBE Outreach Director, Grace Diaz, at gdiaz@providenceri.gov, for review **prior to bid submission**. This waiver applies only to the current bid which you are submitting to the City of Providence and does not apply to other bids your company may submit in the future. **In case a waiver is needed, City Department Directors should not recommend a bidder for an award if this form is not included, absent or is not signed by the city of Providence MBE/WBE director.**

Prime Bidder: _____ Contact Email and Phone _____

Company Name, Address: _____ Trade _____

Project /Item Description (as seen on RFP):

To receive a waiver, you must list the certified MBE and/or WBE companies you contacted, the name of the primary individual with whom you interacted, and the reason the MBE/WBE company could not participate on this project.

MBE/WBE Company Name	Individual's Name	Company Name	Why did you choose not to work with this company?

I acknowledge the City of Providence's goal of a combined MBE/WBE participation is 20% of the total bid value. I am requesting a waiver of _____ % MBE/WBE (20% minus the value of **Box F** on the Subcontractor Disclosure Form). If an opportunity is identified to subcontract any task associated with the fulfillment of this contract, a good faith effort will be made to select MBE/WBE certified businesses as partners.

Signature of Prime Contractor /
or Duly Authorized Representative

Printed Name

Date Signed

Signature of City of Providence
MBE/WBE Outreach Director /
or Duly Authorized Representative

Printed Name of City of Providence
MBE/WBE Outreach Director

Date Signed



**BOARD OF CONTRACT AND SUPPLY
CITY OF PROVIDENCE, RHODE ISLAND**

SUPPLEMENTAL INFORMATION

If the issuing department for this RFP determines that your firm's bid is best suited to accommodate their need, you will be asked to provide proof of the following prior to formalizing an award.

An inability to provide the outlined items at the request of the department may lead to the disqualification of your bid.

*This information is **NOT** requested to be provided in your initial bid that you will submit to the City Clerk's office by the "date to be opened" noted on page 1. This list only serves as a list of items that your firm should be ready to provide on request.*

All bids submitted to the City Clerk become public record. Failure to follow instructions could result in information considered private being posted to the city's Open Meetings Portal and made available as a public record.

You must be able to provide:

- Business Tax ID will be requested after an award is approved by the Board of Contract and Supply.
- Proof of Insurance.
- Certificate of Good Standing with the Rhode Island Secretary of State.
- Qualifications and Past Project References
- Current Work on Hand



**BOARD OF CONTRACT AND SUPPLY
CITY OF PROVIDENCE, RHODE ISLAND**

SUPPLEMENTAL BID FORM

To whom it may concern:

1. The undersigned, having familiarized (himself) (themselves) (itself) with the **Re-Bid Education Center & Events Pavilion at the Roger Williams Park Zoo** bid affecting the cost of work, and with the Contract Documents (which includes the Invitation for Bids, Instructions to Bidders, Form of Bid Bond, Form of Agreements, form of Non-Collusive Affidavit, Addenda (if any), Drawings, Technical Specification, Form of Surety Bond(s); as prepared by the Providence Parks Department, and on file in the office of the City Clerk 3rd Floor, City Hall, Providence, RI 02903, hereby proposes to furnish all supervision, technical personnel, labor, materials, machinery, tools, equipment and services including utility and transportation services, and to perform such other required work for the **Re-Bid Education Center & Events Pavilion at the Roger Williams Park Zoo** and such other required and incidental work, complete, all in accordance with the above listed documents and for the unit prices for work in-place for the following items and quantities.

2. In submitting this Bid, the bidder understands that the right is reserved by The Providence Parks Department to reject any and all Bids, If written notice of acceptance of this Bid is mailed, telegraphed or delivered to the undersigned within (90) days after the opening thereof, or at any time thereafter before this Bid is withdrawn, the undersigned agrees to execute and deliver an Agreement in the prescribed form and furnish the required bond within (10) days after the Agreement is presented to him/her for signature.

Herewith in accordance with the instructions to Bidders.

3. Attached hereto is an affidavit in proof that the undersigned has not colluded with any person in respect to this. Bid or any bids for the Contractor for which this Bid is submitted. Also attached is a Statement of Bidder's Qualifications.

4. application unit prices are contained in the Agreement (established as the result of either a Unit Price Bid or a Supplemental Schedule of Unit Prices), the City of Providence may order the Contractor to proceed with desired changes in the work, the value of such changes to be determined by the measured quantities involved and the application unit prices specified in the Contract.

5. The City of Providence reserves the right to determine the lowest responsible Bidder based on past experience with the City and/or recommendations by City and/or state agencies with an interest in this procurement. The City reserves the right to award the project to the appropriate bidder in the best interest of the City of Providence.

CERTIFICATION OF NON-SEGREGATED FACILITIES

The Bidder certifies that he/she does not maintain or provide for his/her employees any segregated facilities at any of his establishments, and that he/she does not permit his/her employees to perform their services at any location, under his/her control, where segregation facilities are maintained. The Bidder agrees that a breach of this certification will be a violation of the Equal Opportunity Clause in any contract resulting from acceptance of this Bid. As used in this certification, term "segregation facilities" means any waiting rooms, work rooms, rest rooms and wash rooms, restaurants and other eating areas, time clocks, locker rooms and other storage or dressing areas, parking lots, drinking fountains, recreation or entertainment areas, transportation and housing facilities provided for employee which are segregated by explicit directive or are in fact segregated on basis of race, color, religion, or national origin, because of habit, local custom, or otherwise. The Bidder agrees that (except where he/she has obtained identical certification from proposed subcontractors for specific time periods) he/she will obtain identical certification from proposed subcontractor prior to the award of subcontracts exceeding \$10,000.00 which are not exempt from provisions of the Equal Opportunity Clause, and that he /she will retain such certifications in his/her files.

NOTE: The penalty for making false statements in offers is prescribed in 18 U.S.C. & 1001.



Procurement #:

**BOARD OF CONTRACT AND SUPPLY
CITY OF PROVIDENCE, RHODE ISLAND**

DATE _____, 20__

Name of Bidder and Official Address:

Name of Authorized Representative (Contact):

By _____
(Signature)
Title _____

E-Mail: _____

Phone: _____

Bidder shall indicate, in space provided,
the earliest possible Project Start-up Date: _____, 20__

ADDENDA: The undersigned acknowledges receipt of the following Addenda, if any, and has included the provisions thereof in this Bid (If Any):

<u>Addendum No.</u>	<u>Date</u>	<u>Addendum No.</u>	<u>Date</u>
_____	_____, 20__	_____	_____, 20__
_____	_____, 20__	_____	_____, 20__
_____	_____, 20__	_____	_____, 20__
_____	_____, 20__	_____	_____, 20__

Sub-Contractors (If Any):

Name: _____ **Scope of Work:** _____ MBE / WBE

Name: _____ **Scope of Work:** _____ MBE / WBE

Name: _____ **Scope of Work:** _____ MBE / WBE



**BOARD OF CONTRACT AND SUPPLY
CITY OF PROVIDENCE, RHODE ISLAND**

APPRENTICE REQUIREMENTS

Attention of prospective bidders is called to the fact that this project is to be bid upon and executed under the City of Providence Code of Ordinances Chapter 21 Art. II Section 21-28.1 c(1) and (2) related to utilizing apprentices in the contract. This ordinance outlines requirements for utilizing not less than 15% of total hours worked by apprentices. The City may lower this percentage only if it determines in writing that compliance is not feasible or that it would be unduly cost prohibitive to the project. The attention of prospective bidders is also called to the fact that reporting the efforts undertaken and progress towards achieving the requirements in this ordinance is a condition for payment. Compliance reporting shall be submitted with any contract payment requisition, in a format to be specified by the City. This demonstration of compliance through such reports shall be a condition of the requisition for payment to be processed. Upon the contract being awarded to the successful bidder, a mandatory meeting will be scheduled to review the project requirements relative to apprenticeship requirements and the process and protocols by which these goals will be achieved. At this meeting, specific forms and procedures for the documentation and achievement of these requirements by the successful bidder will be provided, discussed and agreed upon for the execution of the contract.

FIRST SOURCE REQUIREMENTS

Attention of prospective bidders is called to the fact that this project is to be bid upon and executed under the City of Providence Code of Ordinances Chapter 21 Art. III 1/2 First Source Agreements Sec. 21-91 through 21-96. This ordinance outlines requirements for hiring Providence residents to work on this project. The City may waive this requirement only upon a determination in writing that qualified residents of Providence are not available for the project, pursuant to Sec. 21-94(e). The attention of prospective bidders is called to the fact that reporting the efforts undertaken and progress towards achieving the requirements in this ordinance is a condition for payment. Compliance reporting shall be submitted with any contract payment requisition, in a format to be specified by the City. This demonstration of compliance through such reports shall be a condition of the requisition for payment to be processed. Upon the contract being awarded to the successful bidder, a mandatory meeting will be scheduled to review the project requirements relative to the First Source Agreements and the process and protocols by which these goals will be achieved. At this meeting, specific forms and procedures for the documentation and achievement of these requirements by the successful bidder will be provided, discussed and agreed upon for the execution of the contract.



**BOARD OF CONTRACT AND SUPPLY
CITY OF PROVIDENCE, RHODE ISLAND**

CITY OF PROVIDENCE STANDARD TERMS & CONDITIONS

1. The terms “you” and “your” contained herein refer to the person or entity that is a party to the agreement with the City of Providence (“the City”) and to such person’s or entity’s employees, officers, and agents.
2. The Request For Proposals (“RFP”) and these Standard Terms and Conditions together constitute the entire agreement of the parties (“the Agreement”) with regard to any and all matters. By your submission of a bid proposal or response to the City’s RFP, you accept these Standard Terms & Conditions and agree that they supersede any conflicting provisions provided by bid or in any terms and conditions contained or linked within a bid and/or response. Changes in the terms and conditions of the Agreement, or the scope of work thereunder, may only be made by a writing signed by the parties.
3. You are an independent contractor and in no way does this Agreement render you an employee or agent of the City or entitle you to fringe benefits, workers’ compensation, pension obligations, retirement or any other employment benefits. The City shall not deduct federal or state income taxes, social security or Medicare withholdings, or any other taxes required to be deducted by an employer, and this is your responsibility to yourself and your employees and agents.
4. You shall not assign your rights and obligations under this Agreement without the prior written consent of the City. Any assignment without prior written consent of the City shall be voidable at the election of the City. The City retains the right to refuse any and all assignments in the City’s sole and absolute discretion.
5. Invoices submitted to the City shall be payable sixty (60) days from the time of receipt by the City. Invoices shall include support documentation necessary to evidence completion of the work being invoiced. The City may request any other reasonable documentation in support of an invoice. The time for payment shall not commence, and invoices shall not be processed for payment, until you provide reasonably sufficient support documentation. In no circumstances shall the City be obligated to pay or shall you be entitled to receive interest on any overdue invoice or payment. In no circumstances shall the City be obligated to pay any costs associated with your collection of an outstanding invoice.
6. For contracts involving construction, alteration, and/or repair work, the provisions of applicable state labor law concerning payment of prevailing wage rates (R.I. Gen. Laws §§ 37-13-1 et seq., as amended) and the City’s First Source Ordinance (Providence Code of Ordinances §§ 21-91 et seq., as amended) apply.
7. With regard to any issues, claims, or controversies that may arise under this Agreement, the City shall not be required to submit to dispute resolution or mandatory/binding arbitration. Nothing prevents the parties from mutually agreeing to settle any disputes using mediation or non-binding arbitration.
8. To the fullest extent permitted by law, you shall indemnify, defend, and hold harmless the City, its employees, officers, agents, and assigns from and against any and all claims, damages, losses, allegations, demands, actions, causes of action, suits, obligations, fines, penalties, judgments, liabilities, costs and expenses, including but not limited to attorneys’ fees, of any nature whatsoever arising out of, in connection with, or resulting from the performance of the work provided in the Agreement.
9. You shall maintain throughout the term of this Agreement the insurance coverage that is required by the RFP or, if none is required in the RFP, insurance coverage that is considered in your industry to be commercially reasonable, and you agree to name the City as an additional insured on your general liability policy and on any umbrella policy you carry.
10. The City shall not subject itself to any contractual limitations on liability. The City shall have the time permitted within the applicable statute of limitations, and no less, to bring or assert any and all causes of action, suits, claims or demands the City may have arising out of, in connection with, or resulting from the performance of the work provided in the Agreement, and in no event does the City agree to limit your liability to the price of the Agreement or any other monetary limit.



**BOARD OF CONTRACT AND SUPPLY
CITY OF PROVIDENCE, RHODE ISLAND**

11. The City may terminate this Agreement upon five (5) days' written notice to you if you fail to observe any of the terms and conditions of this Agreement, or if the City believes your ability to perform the terms and conditions of this Agreement has been materially impaired in any way, including but in no way limited to loss of insurance coverage, lapsing of a surety bond, if required, declaration of bankruptcy, or appointment of a receiver. In the event of termination by the City, you shall be entitled to just and equitable compensation for any satisfactory work completed and expenses incurred up to the date of termination.
12. Written notice hereunder shall be deemed to have been duly served if delivered in person to the individual or member of the firm or entity or to an officer of the entity for whom it was intended, or if delivered at or sent by registered or certified mail to the last business address known by the party providing notice.
13. In no event shall the Agreement automatically renew or be extended without a writing signed by the parties.
14. You agree that products produced or resulting from the performance of the Agreement are the sole property of the City and may not be used by you without the express written permission of the City.
15. For any Agreement involving the sharing or exchange of data involving potentially confidential and/or personal information, you shall comply with any and all state and/or federal laws or regulations applicable to confidential and/or personal information you receive from the City, including but not limited to the Rhode Island Identity Theft Protection Act, R.I. Gen. Laws § 11-49.3-1, during the term of the Agreement. You shall implement and maintain appropriate physical, technical, and administrative security measures for the protection of, and to prevent access to, use, or disclosure of, confidential and/or personal information. In the event of a breach of such information, you shall notify the City of such breach immediately, but in no event later than twenty-four (24) hours after discovery of such breach.
16. The Agreement is governed by the laws of the State of Rhode Island. You expressly submit yourself to and agree that any and all actions arising out of, in connection with, or resulting from the performance of the Agreement or relationship between the parties shall occur solely in the venue and jurisdiction of the State of Rhode Island or the federal court located in Rhode Island.
17. The failure of the City to require performance of any provision shall not affect the City's right to require performance at any time thereafter, nor shall a waiver of any breach or default of this Agreement constitute a waiver of any subsequent breach or default or a waiver of the provision itself.
18. If any term or provision of this Agreement, or the application thereof to any person or circumstance shall, in any extent, be invalid or unenforceable, the remainder of this Agreement shall not be affected thereby, and each term and provision shall be valid and enforceable to the fullest extent permitted by law.



**BOARD OF CONTRACT AND SUPPLY
CITY OF PROVIDENCE, RHODE ISLAND**

PREVAILING WAGE

This project qualifies for prevailing wages per the Prevailing Wages Statute or the Davis Bacon Act (HUD). Certified payrolls will need to be submitted to the owner for all hours worked on site for this project.

The Wage Decision for this project shall be as recorded on the Bid Date and is available on the RI Department of Labor website.

Federal Labor Standards

U.S. Department of Housing & Urban Development

Applicability

The Project of Program to which the Construction work covered by this contract pertains is being assisted by the United States of America and the following Federal Labor Standards Provisions are included in this Contract pursuant to the provisions applicable to such Federal assistance.

- A.1. (i) **Minimum Wages.** All laborers and mechanics employed or working up on the site of the work (or under the United States Housing Act of 1937 or under the Housing Act of 1949 in the construction of development of the project) will be paid unconditionally and not less often than once a week, and without subsequent deduction or rebate on any account (except such payroll deductions as are permitted by regulations issued by the Secretary of Labor under the Copeland Act (29 CFR Part 3), the full amount of wages and bona fide fringe benefits (or cash equivalents thereof) due at time of payment computed at rates not less than those contained in the wage determination of the Secretary of labor which is attached hereto and made a part hereof, regardless of any contractual relationship which may be alleged to exist between the contractor and such laborers and mechanics. Contributions made or costs reasonably anticipated for bona fide fringe benefits under Section 1(b)(2) of the Davis-Bacon Act on behalf of laborers or mechanics are considered wages paid to such laborers or mechanics, subject to the provisions of 29 CFR 5.5(a)(1)(iv); also, regular contributions made or costs incurred for more than weekly period (but not less often than quarterly) under plans, funds, or programs, which cover the particular weekly period, are deemed to be constructively made or incurred during such weekly period. Such laborers and mechanics shall be paid the appropriate wage rate and fringe benefits on the wage determination for the classification or work actually performed, without regard to skill, excepts as provided in 29 CFR Part 5.5 (a)(4). Laborers or mechanics performing work in more than one classification may be compensated at the rate specified for each classification for the time actually worked therein: Provided, that the employer's payroll records accurately set forth the time spent in each classification in which work is performed. The wage determination (including any additional classification and wage rates conformed under 29 CFT part 5.5(a)(1)(ii) and the Davis-Bacon poster (WH-1321) shall be posted at all times by the contractor and its subcontractors at the site of the work in a prominent and accessible place where it can be easily seen by the workers.
- (ii) (a) Any class of laborers or mechanics which is not listed in the wage determination and which is to be employed under the contact shall be classified in conformance with the wage determination. HUD shall approve an additional classification and wage rate and fringe benefits therefore only when the following criteria have been met:
- (1) The work to be performed by the classification requested is not performed by a classification in the wage determination; and
 - (2) The classification is utilized in the area by the construction industry; and
 - (3) The proposed wage rate, including any bona fide fringe benefits, bears a relationship to the wage rates contained in the wage determination.
- (b) If the contractor and the laborers and mechanics to be employed in the classification (if known), or their representatives, and HUD or its designee on the classification and wage rate (including the amount designated for fringe benefits where appropriate), a report of the action taken shall be sent by HUD or its designee to the Administrator of the Wage and Hour Division, Employment Standards Administration, U.S. Department of labor, Washington, D.C. 20210. The Administrator, or an authorized representative, will approve, modify, or disapprove every additional classification action within 30 days of



BOARD OF CONTRACT AND SUPPLY
CITY OF PROVIDENCE, RHODE ISLAND

receipt and so advise HUD or its designee or will notify HUD or its designee within the 30-day period that additional time is necessary. (Approved by the Office of Management and Budget under OMB control number 1215-0140.)

- (c) In the event the contractor, the laborers or mechanics to be employed in the classification or their representatives, and HUD or its designee do not agree on the proposed classification and wage rate (including the amount designated for fringe benefits, where appropriate), HUD or its designee shall refer the questions, including the views of all interested parties and the recommendation of HUD or its designee to the Administrator for determination. The Administrator, or an authorized representative, will issue a determination within 30 days of receipt and so advise HUD or its designee or will notify HUD or its designee within the 30-day period that additional time is necessary. (Approved by the Office of Management and Budget under OMB Control Number 1215-0140.)
- (d) The wage rate (including fringe benefits where appropriate) determined pursuant to subparagraphs (1)(b) or (c) of this paragraph, shall be paid to all workers performing work in the classification under this contract from the first day on which work is performed in the classification.
- (iii) Whenever the minimum wage rate prescribed in the contract for a class of laborers or mechanics includes a fringe benefit which is not expressed as an hourly rate, the contractor shall either pay the benefit as stated in the wage determination or shall pay another bona fide fringe benefit or an hourly cash equivalent thereof.
- (iv) If the contractor does not make payments to a trustee or other third person, the contractor may consider as part of the wages of any laborer or mechanic the amount of any costs reasonably anticipated in providing bona fide fringe benefits under a plan or program, Provided, That the Secretary of Labor has found, upon the written request of the contractor, that the applicable standards of the Davis-Bacon Act have been met. The Secretary of Labor may require the contractor to set aside in a separate account assets for the meeting of obligations under the plan or program. (Approved by the Office of Management and Budget under OMB Control Number 1215-0140.)
2. Withholding. HUD or its designee shall upon its own action or upon written request of an authorized representative of the Department of Labor withhold or cause to be withheld from the contractor under this contract or any other Federal contract with the same prime contractor, or any other Federally-assisted contract subject to Davis-Bacon prevailing wage requirements, which is held by the same prime contractor so much that the accrued payments or advances as may be considered necessary to pay laborers and mechanics, including apprentices, trainees and helpers, employed by the contractor or any subcontractor the full amount of wages required by the contract. In the event of failure to pay any laborer or mechanic, including any apprentice, trainee or helper, employed or working on the site of the work (or under the United States Housing Act of 1937 or under the Housing Act of 1949 in the construction or development of the project), all or part of the wages required by the contract. HUD or its designee may, after written notice to the contractor, sponsor, applicant, or owner, take such action as may be necessary to cause the suspension of any further payment, advance, or guarantee of funds until such violations have ceased. HUD or its designee may, after written notice to the contractor, disburse such amounts withheld for and on account of the contractor or subcontractor to the respective employees to whom they are due. The comptroller General shall make such disbursements in the case of direct Davis-Bacon Act contracts.
3. (i) Payrolls and basic records. Payrolls and basic record relating thereto shall be maintained by the contractor during the course of the work preserved for a period of three years thereafter for all laborers and mechanics working at the site of the work (or under the United States Housing Act of 1937, or under the Housing Act of 1949, in the construction or development of the project). Such records shall contain the name, address, and social security number of each such worker, his or her correct classification, hourly rates of wages paid (including rates of contributions or costs anticipated for bona fide fringe benefits or cash equivalents thereof of the types described in Section 1(b)(2)(B) of the Davis-Bacon Act), daily and weekly number of hours worked, deductions made and actual wages paid. Whenever the Secretary of labor has found under 29 CFR 5.5 (a)(1)(iv) that the wages of any laborer or mechanic include the amount of any costs reasonable anticipated in providing benefits under a plan or program described in Section 1(b)(2)(B) or the Davis-Bacon Act, the contractor shall maintain records which show that the commitment to provide such benefits is enforceable, that the plan or program is financially responsible, and that the plan or program has been communicated in writing to the laborers or mechanics affected, and records which show the costs anticipated or the actual cost incurred in providing such benefits. Contractors employing apprentices or trainees under approved programs shall maintain written evidence of the registration of apprenticeship and certification of trainee programs, the registration of the apprentices and trainees, and the ratios and wage rates prescribed in the applicable programs. (Approved by the Office of Management and Budget under OMB Control Numbers 1215-0140 and 1215-0017.)



**BOARD OF CONTRACT AND SUPPLY
CITY OF PROVIDENCE, RHODE ISLAND**

- (ii) (a) The contractor shall submit weekly for each in which any contract work is performed a copy of all payrolls to HUD or its designee if the agency is a party to the contract, but if the agency is not such a party, the contractor will submit the payrolls to the applicant, sponsor or owner, as the case may be, for transmission to HUD or its designee. The payrolls submitted shall set out accurately and completely all of the information required to be maintained under 29 CFR Part 5.5(a)(3)(i). This information may be submitted in any form desired. Optional Form WH-34 is available for this purpose and may be purchased from the Superintendent of Documents (Federal Stock Number 029-005-00014-1), Government Printing Office, Washington, Dc 20402. The prime contractor is responsible for the submission of copies of payrolls by all subcontractors. (Approved by the Office of Management and Budget under OMB Control Number 1215-0149.)
- (b) Each payroll submitted shall be accompanied by a "Statement of Compliance," signed by the contractor or his or her agent who pays or supervises the payment of the persons employed under the contract and shall certify the following:
- (1) That the payroll for the payroll period contains the information required to be maintained under 20 CFR Part 5.5 (a)(3)(i) and that such information is correct and complete;
- (2) That each laborer or mechanic (including each helper, apprentice, and trainee) employed on the contract during the payroll period has been paid the full weekly wages earned, without rebate, either directly or indirectly, and that no deductions have been made either directly or indirectly from the full wages earned, other than permissible deductions as set forth in 29 CFR Part 3;
- (3) That each laborer or mechanic has been paid not less than the applicable wage rates and fringe benefits or cash equivalents for the classification of work performed, as specified in the applicable wage determination incorporated into the contract.
- (c) The weekly submission of a property executed certification set forth on the reverse side of Optional Form WH-347 shall satisfy the requirement for submission of the "Statement of Compliance" required by paragraph AA.3. (ii)(b) of this section.
- (d) The falsification of any of the above certifications may subject the contractor or subcontractor to civil or criminal prosecution under Section 1001 of Title 18 and Section 231 of Title 31 of the United States Code. (iii)
The contractor or subcontractor shall make the records required under paragraph A.3. (i) of this section available for inspection, copying, or transcription by authorized representatives of HUD or its designee or the Department of Labor, and shall permit such representatives to interview employees during working hours on the job. If the contractor or subcontractor fails to submit the required records or to make them available, HUD or its designee may, after written notice to the contractor, sponsor, applicant, or owner, take such action as may be necessary to cause the suspension of any further payment, advance, or guarantee of funds. Furthermore, failure to submit the required records upon request or to make such records available may be grounds for debarment action pursuant to 29 CFR Part 5.12.
4. (i) Apprentices and Trainees. Apprentices. Apprentices will be permitted to work at less than the predetermined rate for the work they performed when they are employed pursuant to and individually registered in a bona fide apprenticeship program registered with the U.S. Department of Labor, Employment and Training Administration, Bureau of Apprenticeship and Training, or with a State Apprenticeship Agency recognized by the Bureau, or if a person is employed in his or her first 90 days of probationary employment as an apprentice in such an apprentice program, who is not individually registered in the program, but who has been certified by the Bureau of Apprenticeship and Training or a State Apprenticeship Agency (where appropriate) to be eligible for probationary employment as an apprentice. The allowable ratio of apprentices to journeymen on the job site in any craft classification shall not be greater than the ratio permitted to the contractor as to the entire work force under the registered program. Any worker listed on a payroll at an apprentice wage rate, who is not registered or otherwise employed as stated above, shall be paid not less than the applicable wage rate on the wage determination for the classification of work actually performed. In addition, any apprentice performing work on the job site in excess of the ratio permitted under the registered program shall be paid not less than the applicable wage rate on the age determination for the work actually performed. Where a contractor is performing construction on a project in a locality other than that in which its program is registered, the ratios and wage rates (expressed in percentages of the journeyman's hourly rate) specified in the contractor's or subcontractor's registered program shall be observed. Every apprentice must be paid at not less than the rate specified in the registered program for the apprentice's level of progress, expressed as a percentage of the journeymen hourly rate specified in the applicable wage determination. Apprentices shall be paid fringe benefits in accordance with the provisions of the apprenticeship program. If the apprenticeship program does not specify fringe benefits, apprentices must be paid the full amount of fringe benefits listed on the wage determination for the



BOARD OF CONTRACT AND SUPPLY
CITY OF PROVIDENCE, RHODE ISLAND

applicable classification. If the Administrator determines that a different practice prevails for the applicable apprentice classification, fringes shall be paid in accordance with that determination. In the event the Bureau of Apprenticeship and Training, or a State Apprenticeship Agency recognized by the Bureau, withdraws approval of an apprenticeship program, the contractor will no longer be permitted to utilize apprentices at less than the applicable predetermined rate for the work performed until an acceptable program is approved.

(ii) Trainees. Except as provided in 29 CFR 5.16, trainees will not be permitted to work at less than the predetermined rate for the work performed unless they are employed pursuant to and individually registered in a program which has received prior approval, evidenced by formal certification by the U.S. Department of Labor, Employment and Training Administration. The ratio of trainees to journeymen on the job site shall not be greater than permitted under the plan approved by the Employment and Training Administration. Every trainee must be paid not less than the rate specified in the approved program for the trainee's level of progress, expressed as a percentage of the journeyman hourly rate specified in the applicable wage determination. Trainees shall be paid fringe benefits in accordance with the provisions of the trainee program. If the trainee program does not mention fringe benefits, trainees shall be paid the full amount of fringe benefits listed on the wage determination unless the Administrator of the Wage and Hour Division determines that there is an apprenticeship program associated with the corresponding journeyman wage rate on the wage determination which provides for less than full fringe benefits for apprentices. Any employee listed on the payroll at a trainee rate who is not registered and participating in a training plan approved by the Employment and Training Administration shall be paid not less than the applicable wage rate on the wage determination for the work actually performed. In addition, any trainee performing work on the job site in excess of the ratio permitted under the registered program shall be paid not less than the applicable wage rate on the wage determination for the work actually performed. In the event the Employment and Training Administration withdraws approval of a training program, the contractor will no longer be permitted to utilize trainees at less than the applicable predetermined rate for the work performed until an acceptable program is approved.

(iii) Equal employment opportunity. The utilization of apprentices, trainees and journeymen under this part shall be in conformity with the equal employment opportunity requirement of Executive Order 11246, as amended, and 29 CFR Part 30.

5. Compliance with Copeland Act requirements. The contractor shall comply with the requirements of 29 CFR Part 3, which are incorporated by reference in this contract.
6. Subcontracts. The contractor or subcontractor will insert in any subcontract the clauses contained in 29 CFR 5.5(a)(1) through (10) and such other clauses as HUD or its designee may by appropriate instructions require, and also a clause requiring the subcontractors to include these clauses in any lower tier subcontracts. The prime contractor shall be responsible for the compliance by any subcontractor or lower tier subcontractor with all contract clauses in 29 CFR Part 5.5
7. Contracts termination; debarment. A breach of the contract clauses in 29 CFR 5.5 may be grounds for termination of the contract, and for debarment as a contractor as provided in 29 CFR 5.12
8. Compliance with Davis-Bacon and Related Act Requirements. All ruling and interpretations of the Davis-Bacon and Related Act contained in 29 CFR Parts 1, 3, and 5 are herein incorporated by reference in this contract.
9. Disputes concerning labor standards. Disputes arising out of the labor standards provisions of this contract shall not be subject to the general disputes clause of this contract. Such disputes shall be resolved in accordance with the procedures of the Department of Labor set forth in 29 CFR Parts 5, 6, and 7. Disputes within the meaning of this clause include disputes between the contractor (or any of its subcontractors) and HUD or its designee, the U.S. Department of Labor, or the employees or their representatives.
10. (i) Certification of Eligibility. By entering in to this contract, the contractor certifies that neither it (nor he or she) nor any person or firm who has an interest in the contractor's firm is a person or firm ineligible to be awarded Government contracts by virtue of Section 3(a) of the Davis-Bacon Act or 29 CFR 5.12(a)(1) or to be awarded HUD contracts or participate in HUD programs pursuant to 24 CFR part 24.

(ii) No part of this contract shall be subcontracted to any person or firm ineligible for award of a Government contract by virtue of Section 3(a) of the Davis-Bacon Act of 29 CFR 5.12(a)(1) or to be awarded HUD contracts or participate in HUD programs pursuant to 24 CFR Part 24.

(iii) The penalty to making false statements is prescribed in the U.S. Criminal Code, 18 U.S.C. 1001. Additionally, U.S. Criminal Code, Section 1010, Title 18, U.S.C., "Federal Housing Administration transaction", provides in part: "Whoever,



**BOARD OF CONTRACT AND SUPPLY
CITY OF PROVIDENCE, RHODE ISLAND**

for the purpose of ...influencing in any way the action of such Administration...makes, utter or publishes any statement, knowing the same to be false...shall be fined not more than \$5,000 or imprisoned not more than two years, or both.”

11. Complaints, Proceedings, or Testimony by Employees. No laborer or mechanic to whom the wage, salary, or other labor standards provisions of this Contract are applicable shall be discharged or in any other manner discriminated against by the Contractor or any subcontractor because such employee has filed any complaint or instituted or caused to be instituted any proceeding or has testified or is about to testify in any proceeding under or relating to the labor standards applicable under this Contract to his employer.

B. Contract Work Hours and Safety Standards Act. As used in this paragraph, the terms “laborers” and “mechanics” include watchmen and guards.

(1) Overtime requirements. No contractor or subcontractor contracting for any part of the contract work which may require or involve the employment of laborers or mechanics shall require or permit any such laborer or mechanic in any workweek in which he or she is employed on such work to work in excess of forty hours in such workweek unless such laborer or mechanic receives compensation at a rate not less than one and one-half times the basic rate of pay for all hours worked in excess of forty hours in such workweek.

(2) Violation; liability for unpaid wages; liquidated damages. In the event of any violation of the clause set forth in subparagraph (1) or this paragraph, the contractor and any subcontractor responsible therefore shall be liable for the unpaid wages. In addition, such contractor and subcontractor shall be liable to the United States (in case of work done under contract for the District of Columbia or a territory, to such District or to such territory), for liquidated damages. Such liquidated damages shall be computed with respect to each individual laborer or mechanic, including watchmen and guards, employed in violation of the clause set forth in subparagraph (1) of this paragraph, in the sum of \$25 for each calendar day on which such individual was required or permitted to work in excess of forty hours without payment of the overtime wages required by the clause set forth in subparagraph (1) of this paragraph.

(3) Withholding for unpaid wages for liquidated damages. HUD or its designees shall upon its own action or upon written request of an authorized representative of the Department of Labor withhold of cause to be withheld from any moneys payable on account of work performed by the contractor or subcontractor under any such contract or any other Federal contract with the same prime contract, or any other Federally-assisted contract subject to the Contract Work Hours and Safety Standards Act, which is held by the same prime contractor such sums as may be determined to be necessary to satisfy any liabilities of such contractor or subcontractor for unpaid wages and liquidated damages as provided in the clause set forth in subparagraph (2) of this paragraph.

(4) Subcontracts. The contractor or subcontractor shall insert in any subcontracts the clauses set forth in subparagraph (1) through (4) of this paragraph and also a clause requiring the subcontractors to include these clauses in any lower tier subcontracts. The prime contractor shall be responsible for compliance by any subcontractor or lower tier subcontractor with the clauses set forth in subparagraphs (1) through (4) of this paragraph.

C. Health and Safety

(1) No laborer or mechanic shall be required to work in surrounding or under working conditions which are unsanitary, hazardous, or dangerous to his health and safety as determined under construction safety and health standards promulgated by the Secretary of Labor by regulation.

(2) The Contractor shall comply with all regulations issued by the Secretary of Labor pursuant to Title 29 Part 1926 (formerly Part 1518) and failure to comply may result in imposition of sanctions pursuant to the Contract Work Hours and Safety Standards Act (Public Law 91-54, 83 Stat. 96).

(3) The Contractor shall include the provisions of this Article in every subcontract so that such provisions will be binding on each subcontractor. The Contractor shall take such action with respect to any subcontract as the Secretary of Housing and Urban Development or the Secretary of Labor shall direct as a means of enforcing such provisions.



**BOARD OF CONTRACT AND SUPPLY
CITY OF PROVIDENCE, RHODE ISLAND**

BID PACKAGE SPECIFICATIONS

Project Description:

RE-BID EDUCATION CENTER & EVENTS PAVILION AT THE ROGER WILLIAMS PARK ZOO

BASE BID: Work of the Project includes the Re-Bid Education Center & Events Pavilion at the Roger Williams Park Zoo as described on the drawings and in this project manual.

In addition to stating the Total Base Bid, The bidder shall state Unit Prices for related work listed under each bid item which represents the work items included in the Total Base Bid. The Unit Prices are quoted for computing adjustments to the Base Bid prior to Contract award, as well as during the course of construction, based upon extra work ordered by the City or for work countermanded, reduced or omitted by the City in order to stay within the Project budget.

Base Bid Items and Unit prices are to be Completed prices to be added or deducted on the basis of quantities of work involved, for each item in place in the unit indicated.

BASE BID:

All work pertaining to the construction of the new **Education Center, Pavilion & Ambassador Animal Building** as described on the drawings and in this project manual.

All Work Included in this Project Base Bid Shall be Completed for the lump sum of:

_____ Dollars

(\$ _____), **TOTAL BASE BID**

ALLOWANCES:

We have included the specified Allowances, from Section 01 21 00 in Division 1 of the Specifications, in the above Base Bid sum as follows:

Allowance No. 1 – Signage for the Education Center & Ambassador Animal Building	\$ 45,000.00
Allowance No. 2 - Signage for the Events Pavilion	\$ 5,000.00
Allowance No. 3 – Furniture for the Education Center & Ambassador Animal Building	\$ 250,000.00
Allowance No. 4 – Furniture for the Events Pavilion	\$ 50,000.00
Allowance No. 5 - Modifications necessary to new construction due to unforeseen conditions (Education Center & Ambassador Animal Building)	\$ 400,000.00
Allowance No. 6 - Modifications necessary to new construction due to unforeseen conditions (Events Pavilion)	\$ 100,000.00



**BOARD OF CONTRACT AND SUPPLY
CITY OF PROVIDENCE, RHODE ISLAND**

Allowance No. 7 - Remove and dispose off-site unsuitable materials/soils (non-hazardous) and replace with gravel and backfill.	\$ 50,000.00
Allowance No. 8: New Electrical Service:	\$ 80,000.00
Allowance No. 9 – Testing & Inspection for the Education Center & Ambassador Animal Building	\$ 10,000.00
<u>Allowance No. 10 – Testing & Inspection for the Events Pavilion</u>	<u>\$ 10,000.00</u>
 Grand Total of all ten Allowances	 \$ 1,000,000.00

UNIT PRICES:

<u>Item Description</u>	<u>Unit Quantity</u>	<u>Unit Value</u>
a. Excavate and dispose off site bedrock and ledge	One Cubic Yard	\$ _____
b. Remove and dispose off site boulders over 2 Cubic Yards in size (Base Bid includes 2 Cubic Yards & under)	One Cubic Yard	\$ _____
c. Remove and dispose off-site unsuitable materials/soils (non-hazardous) and replace with gravel and backfill.	One Cubic Yard	\$ _____
d. Furnish and install 4" deep loam and grass seed	One Square Yard	\$ _____
e. Furnish and install compacted "gravel fill" as specified.	One Cubic Yard.	\$ _____

Please note that the list above is not intended to include all items required to complete the base bid scope of work but can and shall be used to adjust the contract prior to or after award – in the best interest of the City of Providence.

BIDDER: _____



**BOARD OF CONTRACT AND SUPPLY
CITY OF PROVIDENCE, RHODE ISLAND**

BID DOCUMENTS:

The complete set of Bid Documents consists of the Bid Form, Technical Specifications, Minority Participation Forms, and the following Drawings:

DRAWINGS:

GENERAL

- G0.0 PROJECT REFERENCE PLAN
- G1.0 EDUCATION CENTER CODE AND BUILDING PERFORMANCE
- G1.1 EVENT PAVILION CODE PLAN
- G1.2 AMBASSADOR ANIMAL BUILDING CODE PLAN
- G2.0 GENERAL MOUNTING HEIGHTS, GENERAL NOTES
- G2.1 WALL TYPES
- G3.0 ELECTRICAL SERVICE PLAN

CIVIL

- C-1.0 GENERAL NOTES AND LEGEND
- C-2.0 OVERALL PLAN
- C-3.0 DEMOLITION PLAN
- C-4.0 SITE PLAN
- C-5.0 GRADING AND DRAINAGE PLAN
- C-6.0 UTILITIES PLAN
- C-7.0 SOIL EROSION AND SEDIMENT CONTROL PLAN
- C-8.0 CONSTRUCTION DETAILS-I
- C-8.1 CONSTRUCTION DETAILS-2
- C-8.2 CONSTRUCTION DETAILS-3
- C-8.3 CONSTRUCTION DETAILS-4
- C-8.4 CONSTRUCTION DETAILS-5

MEP / FP – BUILDINGS A, B AND C

- M0.0 MECHANICAL LEGENDS & NOTES
- M3.1 MECHANICAL SCHEDULES
- M3.2 MECHANICAL SCHEDULES
- M4.1 MECHANICAL DETAILS
- M4.2 MECHANICAL DETAILS
- M4.3 MECHANICAL DETAILS
- M5.1R MECHANICAL REFERENCE DRAWINGS
- M5.2R MECHANICAL REFERENCE DRAWINGS
- M5.3R MECHANICAL REFERENCE DRAWINGS
- M5.4R MECHANICAL REFERENCE DRAWINGS
- M5.5R MECHANICAL REFERENCE DRAWINGS
- M5.6R MECHANICAL REFERENCE DRAWINGS
- M5.7R MECHANICAL REFERENCE DRAWINGS
- M5.8R MECHANICAL REFERENCE DRAWINGS
- P0.0 PLUMBING LEGEND, GENERAL NOTES, SCHEDULES & DIAGRAMS
- FP0.0 FIRE PROTECTION LEGEND, GENERAL NOTES, AND DIAGRAMS
- E0.0 ELECTRICAL LEGENDS AND NOTES
- ES1.1 ELECTRICAL SITE PLAN



**BOARD OF CONTRACT AND SUPPLY
CITY OF PROVIDENCE, RHODE ISLAND**

- ES1.2 ELECTRICAL SITE PLAN - LIGHTING
- E0.1 ELECTRICAL ONE-LINE DIAGRAM & SCHEDULES
- E0.2 ELECTRICAL ONE-LINE DIAGRAM & SCHEDULES
- E0.3 ELECTRICAL LIFE SAFETY DIAGRAMS & LEGENDS
- E0.4 ELECTRICAL LIGHTING CONTROL DIAGRAMS
- E0.5 ELECTRICAL SCHEDULES & NOTES
- E0.6 ELECTRICAL DETAILS

ARCHITECTURAL – BUILDING A
EDUCATION CENTER

- A-A1.0 FOUNDATION PLAN
- A-A1.1 LOWER LEVEL FLOOR. PLAN
- A-A1.2 UPPER LEVEL FLOOR. PLAN
- A-A1.3 ENLARGED PLANS AND DETAILS
- A-A2.0 EXTERIOR ELEVATIONS
- A-A2.1 EXTERIOR ELEVATIONS
- A-A3.0 BUILDING SECTIONS
- A-A3.1 BUILDING SECTIONS
- A-A3.2 WALL SECTIONS & DETAILS
- A-A3.3 WALL SECTIONS
- A-A3.4 SECTIONS
- A-A3.5 MISCELLANEOUS DETAILS
- A-A4.0 STAIR AND ELEVATOR PLANS AND SECTIONS
- A-A5.0 ROOF PLAN & DETAILS
- A-A5.1 ROOF DETAILS
- A-A5.2 PV PANEL ROOF ATTACHMENT DETAIL
- A-A6.0 DOOR SCHEDULE
- A-A6.1 DOOR & FRAME TYPES
- A-A6.2 DOOR& WINDOW DETAILS
- A-A6.3 WINDOW TYPES
- A-A7.0 INTERIOR ELEVATIONS
- A-A7.1 INTERIOR ELEVATIONS
- A-A7.2 INTERIOR ELEVATIONS
- A-A7.3 INTERIOR ELEVATIONS
- A-A7.4 INTERIOR ELEVATIONS
- A-A7.5 INTERIOR ELEVATIONS
- A-A7.6 INTERIOR ELEVATIONS
- A-A8.0 REFLECTED CEILING PLAN
- A-A9.0 FINISH & MATERIALS SCHEDULE
- A-A9.1 FINISH PLANS
- A-A9.2 FURNITURE PLANS
- A-A10.0 MILLWORK & CASEWORK SECTIONS & DETAILS
- A-A10.1 MILLWORK & CASEWORK SECTIONS & DETAILS

STRUCTURAL – BUILDING A

- S0.1 DESIGN LOADS & GENERAL NOTES
- S0.2 SPECIAL INSPECTIONS
- A-S1.1 FOUNDATION PLAN
- A-S1.2 UPPER LEVEL AND LOW ROOF FRAMING



**BOARD OF CONTRACT AND SUPPLY
CITY OF PROVIDENCE, RHODE ISLAND**

- A-S1.3 ROOF FRAMING PLAN
- A-S2.0 FOUNDATION SECTIONS AND DETAILS
- A-S2.1 BASEPLATE AND MASONRY DETAILS
- A-S3.0 STEEL FRAMING SECTIONS AND DETAILS
- A-S3.1 SECTIONS AND DETAILS
- A-S4.0 LOWER LEVEL SHEAR WALL PLAN
- A-S4.1 SHEAR WALL PLANS

MECHANICAL – BUILDING A

- A-M1.1 MECHANICAL LOWER LEVEL FLOOR PLAN
- A-M1.2 MECHANICAL UPPER LEVEL PLAN
- A-M1.3 MECHANICAL ROOF PLAN
- A-M2.1 MECHANICAL LOWER LEVEL PIPING PLAN
- A-M2.2 MECHANICAL UPPER LEVEL PIPING PLAN

PLUMBING – BUILDING A

- A-P1.0A PLUMBING EDUCATION CENTER UNDERSLAB PART PLAN A
- A-P1.0B PLUMBING EDUCATION CENTER UNDERSLAB PART PLAN B
- A-P1.1A PLUMBING EDUCATION CENTER LOWER LEVEL PART PLAN A
- A-P1.1B PLUMBING EDUCATION CENTER LOWER LEVEL PART PLAN B
- A-P1.2 PLUMBING EDUCATION CENTER UPPER LEVEL FLOOR PLAN
- A-P1.3 PLUMBING EDUCATION CENTER ROOF PLAN

FIRE PROTECTION – BUILDING A

- A-FP1.0 FIRE PROTECTION EDUCATION CENTER FLOOR PLANS

ELECTRICAL – BUILDING A

- A-E1.1 ELECTRICAL LOWER LEVEL FLOOR PLAN – LIGHTING
- A-E1.2 ELECTRICAL UPPER LEVEL FLOOR PLAN – LIGHTING
- A-E2.1 ELECTRICAL LOWER LEVEL FLOOR PLAN – POWER & SIGNAL
- A-E2.2 ELECTRICAL UPPER LEVEL FLOOR PLAN – POWER & SIGNAL
- A-E2.3 ELECTRICAL ROOF PLAN
- A-E2.4 ELECTRICAL ELEVATOR PART PLAN & NOTES

ARCHITECTURAL – BUILDING B

EVENT PAVILION

- B-A1.0 FOUNDATION PLAN
- B-A1.1 1st FLOOR PLAN
- B-A1.2 FURNITURE PLAN
- B-A2.1 EXTERIOR ELEVATIONS
- B-A2.2 3D VIEWS
- B-A3.0 BUILDING SECTIONS
- B-A3.1 WALL SECTIONS & DETAILS
- B-A5.0 ROOF PLAN & DETAILS
- B-A6.0 DOOR AND WINDOW SCHEDULES
- B-A6.1 FINISH SCHEDULE
- B-A7.0 INTERIOR ELEVATIONS
- B-A7.1 INTERIOR ELEVATIONS
- B-A8.0 REFLECTED CEILING PLAN



**BOARD OF CONTRACT AND SUPPLY
CITY OF PROVIDENCE, RHODE ISLAND**

MECHANICAL – BUILDING B

- B-M1.1 MECHANICAL PAVILION DUCTWORK PLANS

PLUMBING – BUILDING B

- B-P1.0 PLUMBING PAVILION UNDERSLAB PLAN
- B-P1.1 PLUMBING PAVILION PART PLANS, NOTES AND SCHEDULES

FIRE PROTECTION – BUILDING B

- B-FP1.0 FIRE PROTECTION PAVILION FLOOR PLAN

ELECTRICAL – BUILDING B

- B-E3.1 ELECTRICAL LOWER LEVEL FLOOR PLAN - LIGHTING
- B-E3.2 ELECTRICAL LOWER LEVEL FLOOR PLAN – POWER & SIGNAL
- B-E3.3 ELECTRICAL LOWER LEVEL PART PLAN – KITCHEN EQUIPMENT

ARCHITECTURAL – BUILDING C

AMBASSADOR ANIMAL BUILDING

- C-A1.1 FIRST FLOOR PLAN
- C-A1.2 SECOND FLOOR PLAN
- C-A2.1 EXTERIOR ELEVATIONS
- C-A3.1 SECTIONS AND DETAILS
- C-A3.2 SECTIONS AND DETAILS
- C-A4.1 STAIR PLANS, SECTIONS AND DETAILS
- C-A5.1 ROOF PLAN AND DETAILS
- C-A6.1 DOOR AND WINDOW SCHEDULES
- C-A6.2 FINISH SCHEDULE
- C-A8.1 FIRST FLOOR REFLECTED CEILING PLAN
- C-A8.2 SECOND FLOOR REFLECTED CEILING PLAN

MECHANICAL – BUILDING C

- C-M1.1 MECHANICAL ANIMAL BUILDING LOWER LEVEL PLAN
- C-M1.2 MECHANICAL ANIMAL BUILDING UPPER LEVEL PLAN

PLUMBING – BUILDING C

- C-P1.0 PLUMBING ANIMAL BUILDING UNDERSLAB PART PLAN
- C-P1.1 PLUMBING ANIMAL BUILDING LOWER LEVEL FLOOR PLAN
- C-P1.2 PLUMBING ANIMAL BUILDING UPPER LEVEL FLOOR PLAN

FIRE PROTECTION – BUILDING C

- C-FP1.0 FIRE PROTECTION ANIMAL BUILDING FLOOR PLANS

ELECTRICAL – BUILDING C

- C-E4.1 ELECTRICAL ANIMAL BUILDING FLOOR PLANS



**BOARD OF CONTRACT AND SUPPLY
CITY OF PROVIDENCE, RHODE ISLAND**

PROJECT MANUAL

CONTRACT CONDITIONS

- 00 65 19.16 Waiver of Lien Form
- 00 65 19.18 Affidavit of General Contractor that all Subcontractors, Suppliers and Laborers Have Been Paid and Hold Harmless Clause
- 00 72 13 General Conditions/A201 2017 Edition
- 00 73 46 Prevailing Wage Rates

TECHNICAL SPECIFICATION:

DIVISION 1 - GENERAL REQUIREMENTS

- 01 10 00 Summary of Work
- 01 10 13 Information Available to Bidders
 - Geotechnical Report
 - Advance Utility Site Plans
- 01 20 00 Price and Payment Procedures
- 01 21 00 Allowances
- 01 31 00 Administrative Requirements
- 01 33 00 Submittal Procedures
- 01 43 00 Quality Requirements
- 01 50 00 Temporary Facilities and Controls
- 01 60 00 Product Requirements
- 01 70 00 Execution Requirements
- 01 74 19 Waste Materials Management and Recycling
- 01 78 00 Closeout Submittals
- 01 81 13 Environmental Goals for the Project
- 01 81 14 Environmental Impact of Materials
- 01 81 22 Indoor Air Quality Management During Construction
- 01 89 00 Site Construction Performance Requirements
- 01 91 00 General Commissioning Requirements

DIVISION 2 – EXISTING CONDITIONS

- 02 41 16 Building Demolition

DIVISION 3 - CONCRETE

- 03 30 00 Cast-in-place Concrete
- 03 30 55 Cast-in-place Concrete (Site)
- 03 35 43 Polished Concrete Floor Finishing
- 03 35 49 Concrete Floor Sealer

DIVISION 4 - MASONRY

- 04 22 24 Reinforced Masonry - Interior
- 04 73 13 Natural Thin Veneer Stone

DIVISION 5 - METALS

- 05 12 00 Structural Steel
- 05 31 00 Steel Deck



**BOARD OF CONTRACT AND SUPPLY
CITY OF PROVIDENCE, RHODE ISLAND**

- 05 50 00 Miscellaneous Metal Work
- 05 51 13 Metal Stairs
- 05 73 16 Ornamental Cable Railing

DIVISION 6 - WOOD AND PLASTICS

- 06 10 00 Rough Carpentry
- 06 16 13 Structural Insulated Panels
- 06 16 15 Composite Nail Base Insulating Sheathing
- 06 17 53 Wood Trusses
- 06 20 10 Carpentry and Millwork
- 06 83 16 Fiberglass Reinforced Plastic Panels

DIVISION 7 - MOISTURE PROTECTION

- 07 11 13 Bituminous Dampproofing
- 07 21 01 Grade Level Insulation Cover Sheet
- 07 21 13 Board Insulation
- 07 21 19 Foamed-In-Place Insulation
- 07 26 16 Under-Slab Vapor Barrier
- 07 27 19 Air Infiltration Barrier
- 07 31 13 Architectural Roof Shingles
- 07 46 24 Cedar Shingle Siding
- 07 46 46 Fiber Cement Soffit & Trim
- 07 54 23 Self-Adhered Thermoplastic Polyolefin Roofing System
- 07 62 10 Aluminum Sheet Metal Flashing and Trim
- 07 62 11 Sheet Metal Flashing
- 07 65 26 Through Wall Flashing Membrane System
- 07 71 23 Gutters and Downspouts
- 07 72 00 Roof Accessories
- 07 84 13 Firestopping
- 07 92 13 Joint Sealants

DIVISION 8 - DOORS AND WINDOWS

- 08 12 13 Steel Door Frames
- 08 13 13 Steel Doors
- 08 14 16 Wood Doors
- 08 14 19 Wood Barn Doors
- 08 14 21 Metal Sliding Shift doors
- 08 31 13 Access Doors
- 08 33 44 Rolling Fire Doors
- 08 36 15 Aluminum & Glass Upward-Acting Sectional Doors
- 08 42 13 Aluminum Entrance Doors
- 08 43 13 Aluminum Storefront System (Thermal Break)
- 08 43 15 Aluminum Storefront System (Non-thermal)
- 08 54 13 Fiberglass Windows
- 08 71 00 Door Hardware
- 08 71 50 Weatherstripping
- 08 81 00 Glass and Glazing
- 08 81 13 Decorative Glass Glazing
- 08 81 15 Decorative Glass Glazing Panel Wall Frame



**BOARD OF CONTRACT AND SUPPLY
CITY OF PROVIDENCE, RHODE ISLAND**

- 08 87 23 Security Glazing Film
- 08 88 13 Fire Rated Glass
- 08 91 10 Metal Louvers

DIVISION 9 - FINISHES

- 09 21 16 Steel Framed Drywall Systems
- 09 28 13 Cementitious Backer Board
- 09 30 13 Ceramic Tile
- 09 30 16 Quarry Tile
- 09 51 23 Acoustical Ceiling Systems
- 09 65 00 Resilient Flooring
- 09 68 14 Entrance Carpet Tile
- 09 81 16 Sound Attenuation Insulation
- 09 84 15 Acoustical Wall Panels
- 09 91 00 Painting

DIVISION 10 - SPECIALTIES

- 10 11 16 Markerboards
- 10 11 23 Tackboards
- 10 14 00 Signage
- 10 14 10 Traffic Control Signage and Steel Bollards
- 10 21 13.17 Phenolic Toilet Partitions
- 10 22 26 Operable Partitions
- 10 26 23.13 Impact Resistant Wall Protection
- 10 28 13 Toilet Room Accessories
- 10 44 13 Fire Extinguishers & Cabinets

DIVISION 11 - EQUIPMENT

- 11 06 00 Miscellaneous Equipment & Products

DIVISION 12 - FURNISHINGS

- 12 24 13 Roll-Up Window Shades
- 12 31 16 Plastic Laminate Casework
- 12 36 45 Porcelain Slab Countertops

DIVISION 13 – SPECIAL CONSTRUCTION

- 13 34 18 Pre-Engineered Timber Column Structure

DIVISION 14 – CONVEYING EQUIPMENT

- 14 24 23 Hydraulic Passenger Elevator
- 14 42 16-Vertical Platform Wheelchair Lift

DIVISION 15 – 20

- Not Used

DIVISION 21 – FIRE PROTECTION

- 21 00 00 Fire Protection

DIVISION 22 - PLUMBING

- 22 00 00 Plumbing



**BOARD OF CONTRACT AND SUPPLY
CITY OF PROVIDENCE, RHODE ISLAND**

DIVISION 23 - HVAC

- 23 00 00 Mechanical

DIVISION 24 – 25

- Not Used

DIVISION 26 - ELECTRICAL

- 26 00 00 Electrical Requirements

DIVISION 27 – 30

- Not Used

DIVISION 31 - EARTHWORK

- 31 00 00 Earthwork
- 31 10 00 Site Clearing
- 31 23 19 Dewatering
- 31 25 00 Erosion and Sedimentation Controls

DIVISION 32 – EXTERIOR IMPROVEMENTS

- 32 12 15 Asphalt Paving
- 32 16 10 Curbing
- 32 17 23 Pavement Markings
- 32 31 13-Chain Link Fence

DIVISION 33 – UTILITIES

- 33 10 00 Water Utilities
- 33 39 00 Sanitary Sewerage Utility Structures
- 33 40 00 Storm Drainage Utilities
- 33 40 20 Warning and Tracer Tape

DIVISION 34 – 48

- Not Used



**BOARD OF CONTRACT AND SUPPLY
CITY OF PROVIDENCE, RHODE ISLAND**

ADDITIONAL INFORMATION REQUIRED WITH BID:

- Qualifications to Perform Work – See Form Below for Information Required
- Minority Participation Forms – 10% MBE / 10 % WBE Goal on this Project
- Addenda (If Any) - Must Be Acknowledged on Bid Form
- Product Information for Items Submitted as ‘Or Equal’ to Specified Materials

PROVISIONS OF THIS PROJECT:

- Upon the Issuance of the Award from the Board of Contract – the City shall issue a Contract to be executed by the City and the vendor incorporating the bid specifications. All Provisions of the Specifications are binding.
- Any Permits Required by the City of Providence and/or State of Rhode Island Shall be Obtained by the Vendor – Permit Fees by the City of Providence Shall be Waived – the State ADA Fee Must be Paid
- The Davis Bacon Act Applies – Prevailing Wages Must Be Paid for On Site Hours – On-Site Interviews will be Conducted During the Project – Employees Shall be Advised of the Prevailing Wage Rates Prior to Mobilization on Site
- Certified payrolls Must be Submitted With Pay Requests Including Monthly Utilizations Form
- Performance and Payment Bonds Must be Submitted within 10 Days of Award or Bid Bond Will be Forfeited
- An Insurance Certificate Shall be Submitted to the City Within 10 Days of Award
- A Copy of the Vendors Contractor’s License Must be Submitted within 10 Days of Award
- All On-Site Personnel Shall be Licensed (If Required) and Shall have Proof of All Licenses Required by the State of Rhode Island to Perform the Work Required
- Pay Requests Must be Submitted on Approved AIA Billing Documents (City will Provide if Needed)
- All Subcontractors Shall be Listed on the Bid Form – All Insurance & Payroll Requirements Apply
 - General Contractor Shall be the Insurance Certificate Holder and the City Shall be Named as ‘Additionally Insured’ with Respect to Liability Insurance
- A Submittal Log Must be Submitted within 10 Days of Award

CLOSE OUT DOCUMENTS:

- Prior to Final Payment the Vendor Shall Provide the Following:
 - Copies of Permits Signed off and Approved (If Any)
 - Operating Manuals and Warranties Shall Be Transferred and/or Delivered
 - Full and Completed As-Built Drawings Shall be Submitted for Approval
 - Training Shall be Provided to City Personnel (If Required)
 - Certification by Manufactures Representative (If Required)



**BOARD OF CONTRACT AND SUPPLY
CITY OF PROVIDENCE, RHODE ISLAND**

QUALIFICATIONS:

Qualifications will be evaluated on the basis of similar project experience for:

- a. Completion of at least 3 similar projects within the past five years.
- b. Size and dollar value of similar completed projects.
- c. Contractor's performance with similar projects. (references will be checked)
- d. Relevant experience of individuals assigned to the project.

Questions regarding this bid package shall be submitted via e-mail to Purchasing at purchasing@providenceri.gov and **Brian Byrnes, Deputy Superintendent of Parks** at bbyrnes@providenceri.gov , no later than seven (7) working days before the bid opening date.



**BOARD OF CONTRACT AND SUPPLY
CITY OF PROVIDENCE, RHODE ISLAND**

[SAMPLE CONSTRUCTION AGREEMENT]

This Construction Agreement (“Agreement”) is made and entered into as of this ____ day of _____ 2024 by and between the **City of Providence Board of Park Commissioners**, having an address of The Dalrymple Boathouse, Roger Williams Park, 1000 Elmwood Ave., Providence, RI (“City”) and **[Contractor Name]**, (“Contractor”), having an address of **[Contractor Address]**.

WITNESSETH:

WHEREAS, the **[Project Location]** is located at **[Project Address], Providence, RI**. The City plans to make improvements in the park under the **[Project Title]** project (the “Project”), all as detailed in Request for Proposals (“RFP”) issued by the City on **[Date of Bid Advertisement]** (attached and incorporated by reference as Exhibit A); and

WHEREAS, the Contractor proposed to handle the Project, as detailed in a responsive bid opened on **[Date of Bid Opening]** (attached and incorporated by reference as Exhibit B); and

WHEREAS, the Board of Contract and Supply awarded the contract to **[Contractor Name]**, at its meeting on **[Date of Award]**.

NOW, THEREFORE, in consideration of the mutual covenants and agreements contained in this Agreement, the Parties agree as follows:

1. **SELECTION.** The City hereby selects the Contractor to provide construction services outlined in its **[Date of Bid Opening]** submission.
2. **TERM.** The term of this agreement shall be from and after the date of execution through completion of the Project, which shall be not later than **[Contract Completion Date]**.
3. **TERMS OF PAYMENT.** The total amount of the awarded contract is **[Contract Award Amount]**. The City shall make a good-faith effort to pay the Contractor within sixty (60) days of receipt of a pay requisition for work completed and accepted, less retainage.
4. **COMPENSATION.** The Contractor shall be paid according to the breakdown contained in its bid package.
5. **INDEMNIFICATION AND LIABILITY.** The Contractor is alone responsible for the safety, efficiency, and adequacy of the construction and for any damage which may result from improper construction, maintenance, or operation. The contractor shall indemnify, defend, and hold harmless the City, and its employees, representatives, agents, successors and assigns (the "City Indemnified Parties") from and against any and all demands, claims, suits, cause or cause of action, whether at law or in equity, costs, expenses and attorneys' fees and any liability whatsoever to anyone for any bodily injury or property damage resulting from or arising out of the willful misconduct or negligent acts or omissions of the



**BOARD OF CONTRACT AND SUPPLY
CITY OF PROVIDENCE, RHODE ISLAND**

Contractor and/or its employees, representatives, subcontractors, and agents in the performance of this Agreement.

6. **RETAINAGE:** The City shall retain 5% of all pay requests paid during the project. When the City and/or its representatives deem the project as “Substantially Complete” or 85% of the work has been completed, the retainage may be reduced to 2.5% for the work completed. The final payment will be released when all the work has been completed, inspected, and approved by the owner’s representative and all close out documents, warranties and as-built plans have been received and approved by the City.
7. **INSURANCE.** The Contractor shall furnish an insurance certificate naming the City as an additional named insured on a primary but non-contributing basis for General Liability.
8. **BINDING EFFECT.** This contract and all the covenants, provisions, and conditions herein contained shall inure to the benefit of and be binding upon the heirs, successors and assigns of the parties. Neuter pronouns shall be read as masculine or feminine, and words in the singular person as plural, if the nature or number of the parties require.
9. **GOVERNING LAW.** This Agreement is entered into pursuant to and shall be governed by and construed in accordance with the laws of the State of Rhode Island.
10. **NATURE OF RELATIONSHIP.** Nothing in this Agreement shall create a partnership, joint venture, trust or other fiduciary relationship between the Contractor and the City.
11. **AMENDMENTS AND SUPPLEMENTS.** The Contractor and the City may amend, modify, supplement, or waive any provisions of this Agreement in such manner as may be agreed upon by the Parties in a written instrument executed by both Parties.
12. **MBE/WBE.** The parties acknowledge that the City sets an MBE goal of 10% and a WBE goal of 10%, and the Contractor will make good faith efforts to comply with these goals.
13. **TERMINATION.** The City may terminate this Agreement at any time upon ninety (90) days prior written notice. This Agreement may be terminated by either party if the other party materially breaches any provision of this Agreement and fails to cure the material breach within 30 days after receiving notice thereof from the non-breaching party. Without limiting the City’s right to terminate this Agreement, the City may suspend the Contractor’s right to access the Project upon any actual, threatened, or suspected breach of this Agreement.
14. **COUNTERPARTS.** This Agreement may be executed in multiple counterparts, each of which shall constitute an original, but all of which shall constitute one document.



**BOARD OF CONTRACT AND SUPPLY
CITY OF PROVIDENCE, RHODE ISLAND**

IN WITNESS WHEREOF, the parties have caused this Agreement to be duly executed as of the date first above written.

City of Providence

By: _____
Brett P. Smiley, Mayor

STATE OF RHODE ISLAND
PROVIDENCE, SC.

In Providence, in said County and State, on the ____day of _____, 2024, before me personally appeared Brett P. Smiley, Mayor and Chairman of the Board of Park Commissioners, to me known and known by me to the party executing the foregoing instrument for and on behalf of the City, and he acknowledged said instrument by him executed to be his free act and deed, his free act and deed in his capacity as aforesaid, and the free act and deed of the City.

Notary Public
My Commission Expires:

Approved as to form and satisfactory to me:

City Solicitor

[Contractor Company Name]

By: _____
[Owners Name]
[Title]

STATE OF RHODE ISLAND
PROVIDENCE, SC.



**BOARD OF CONTRACT AND SUPPLY
CITY OF PROVIDENCE, RHODE ISLAND**

In Providence, in said County and State, on the ____day of _____, 2024, before me personally appeared [**Owners Name**] to me known and known by me to the party executing the foregoing instrument for and on behalf of [**Owners Name**] and he/she/they acknowledged said instrument by him/her/they executed to be his/her/their free act and deed, his/her/their free act and deed in his/her/their capacity as aforesaid, and the free act and deed of [**Contractor Company Name**].

Notary Public
My Commission Expires:



**BOARD OF CONTRACT AND SUPPLY
CITY OF PROVIDENCE, RHODE ISLAND**

TECHNICAL SPECIFICATIONS

PROJECT MANUAL

APRIL 18, 2024

RE-BID
EDUCATION CENTER AND PAVILION
FOR THE
ROGER WILLIAMS PARK ZOO
PROVIDENCE, RHODE ISLAND



SACCOCCIO & ASSOCIATES
ARCHITECTS



1085 PARK AVENUE
CRANSTON, RHODE ISLAND

PROJECT NUMBER 18050

THIS PAGE INTENTIONALLY LEFT BLANK

DOCUMENT 00 00 10

TABLE OF CONTENTS

BIDDING DOCUMENTS, CONTRACT FORMS, AND CONDITIONS OF THE CONTRACT

- Request for Proposals
- Instructions for Submission
- Bid Package Checklist
- Notice to Vendors
- Bid Terms
- Bid Form 1: Bidders Blank
- Bid Form 2: Certification of Bidder
- Bid Form 3: Certificate Regarding Public Records
- Bid Form 4: Affidavit of City Vendor
- WBE/MBE Form Instructions
- MBE/WBE Participation Affidavit
- Subcontractor Disclosure Form
- MBE/WBE Waiver Request Form
- Supplemental Information
- Supplemental Bid Form
- Apprentice Requirements
- First Source Requirements
- City of Providence Standard Terms & Conditions
- Prevailing Wage
- Bid Package Specifications
- Bid Documents
- Additional Information Required with Bid
- Provisions of this Project
- Closeout Documents
- Qualifications
- Sample Construction Agreement

00 65 19.16	Waiver of Lien Form
00 65 19.18	Affidavit of General Contractor that all Subcontractors, Suppliers and Laborers Have Been Paid and Hold Harmless Clause
00 72 13	General Conditions/A201 2017 Edition
00 73 46	Prevailing Wage Rates

SPECIFICATIONS

DIVISION 1 - GENERAL REQUIREMENTS

01 10 00	Summary of Work
01 10 13	Information Available to Bidders <ul style="list-style-type: none">• Geotechnical Report• Advance Utility Site Plans
01 20 00	Price and Payment Procedures

01 21 00	Allowances
01 31 00	Administrative Requirements
01 33 00	Submittal Procedures
01 43 00	Quality Requirements
01 50 00	Temporary Facilities and Controls
01 60 00	Product Requirements
01 70 00	Execution Requirements
01 74 19	Waste Materials Management and Recycling
01 78 00	Closeout Submittals
01 81 13	Environmental Goals for the Project
01 81 14	Environmental Impact of Materials
01 81 22	Indoor Air Quality Management During Construction
01 89 00	Site Construction Performance Requirements
01 91 00	General Commissioning Requirements

DIVISION 2 – EXISTING CONDITIONS

02 41 16	Building Demolition
----------	---------------------

DIVISION 3 - CONCRETE

03 30 00	Cast-in-place Concrete
03 30 55	Cast-in-place Concrete (Site)
03 35 43	Polished Concrete Floor Finishing
03 35 49	Concrete Floor Sealer

DIVISION 4 - MASONRY

04 22 24	Reinforced Masonry - Interior
04 73 13	Natural Thin Veneer Stone

DIVISION 5 - METALS

05 12 00	Structural Steel
05 31 00	Steel Deck
05 50 00	Miscellaneous Metal Work
05 51 13	Metal Stairs
05 73 16	Ornamental Cable Railing

DIVISION 6 - WOOD AND PLASTICS

06 10 00	Rough Carpentry
06 16 13	Structural Insulated Panels
06 16 15	Composite Nail Base Insulating Sheathing
06 17 53	Wood Trusses
06 20 10	Carpentry and Millwork
06 61 16	Solid Surfacing Material
06 83 16	Fiberglass Reinforced Plastic Panels

DIVISION 7 - MOISTURE PROTECTION

07 11 13	Bituminous Dampproofing
07 21 01	Grade Level Insulation Cover Sheet
07 21 13	Board Insulation
07 21 19	Foamed-In-Place Insulation
07 26 16	Under-Slab Vapor Barrier
07 27 19	Air Infiltration Barrier
07 31 13	Architectural Roof Shingles
07 46 24	Cedar Shingle Siding
07 46 46	Fiber Cement Soffit & Trim
07 54 23	Self-Adhered Thermoplastic Polyolefin Roofing System
07 62 10	Aluminum Sheet Metal Flashing and Trim
07 62 11	Sheet Metal Flashing
07 65 26	Through Wall Flashing Membrane System
07 71 23	Gutters and Downspouts
07 72 00	Roof Accessories
07 84 13	Firestopping
07 92 13	Joint Sealants

DIVISION 8 - DOORS AND WINDOWS

08 12 13	Steel Door Frames
08 13 13	Steel Doors
08 14 16	Wood Doors
08 14 19	Wood Barn Doors
08 14 21	Metal Sliding Shift doors
08 31 13	Access Doors
08 33 44	Rolling Fire Doors
08 36 15	Aluminum & Glass Upward-Acting Sectional Doors
08 42 13	Aluminum Entrance Doors
08 43 13	Aluminum Storefront System (Thermal Break)
08 43 15	Aluminum Storefront System (Non-thermal)
08 54 13	Fiberglass Windows
08 71 00	Door Hardware
08 71 50	Weatherstripping
08 81 00	Glass and Glazing
08 81 13	Decorative Glass Glazing
08 81 15	Decorative Glass Glazing Panel Wall Frame
08 87 23	Security Glazing Film
08 88 13	Fire Rated Glass
08 91 10	Metal Louvers

DIVISION 9 - FINISHES

09 21 16	Steel Framed Drywall Systems
09 28 13	Cementitious Backer Board
09 30 13	Ceramic Tile
09 30 16	Quarry Tile

09 51 23 Acoustical Ceiling Systems
09 65 00 Resilient Flooring
09 68 14 Entrance Carpet Tile
09 81 16 Sound Attenuation Insulation
09 84 15 Acoustical Wall Panels
09 91 00 Painting

DIVISION 10 - SPECIALTIES

10 11 16 Markerboards
10 11 23 Tackboards
10 14 00 Signage
10 14 10 Traffic Control Signage and Steel Bollards
10 21 13.17 Phenolic Toilet Partitions
10 22 26 Operable Partitions
10 26 23.13 Impact Resistant Wall Protection
10 28 13 Toilet Room Accessories
10 44 13 Fire Extinguishers & Cabinets

DIVISION 11 - EQUIPMENT

11 06 00 Miscellaneous Equipment & Products

DIVISION 12 - FURNISHINGS

12 24 13 Roll-Up Window Shades
12 31 16 Plastic Laminate Casework
12 36 45 Porcelain Slab Countertops

DIVISION 13 – SPECIAL CONSTRUCTION

13 34 18 Pre-Engineered Timber Column Structure

DIVISION 14 – CONVEYING EQUIPMENT

14 24 23 Hydraulic Passenger Elevator
14 42 16 Vertical Platform Wheelchair Lift

DIVISION 15 – 20

Not Used

DIVISION 21 – FIRE PROTECTION

21 00 00 Fire Protection

DIVISION 22 - PLUMBING

22 00 00 Plumbing

DIVISION 23 - HVAC

23 00 00 Mechanical

DIVISION 24 – 25

Not Used

DIVISION 26 - ELECTRICAL

26 00 00 Electrical Requirements

DIVISION 27 – 30

Not Used

DIVISION 31 - EARTHWORK

31 00 00 Earthwork
31 10 00 Site Clearing
31 23 19 Dewatering
31 25 00 Erosion and Sedimentation Controls

DIVISION 32 – EXTERIOR IMPROVEMENTS

32 12 15 Asphalt Paving
32 16 10 Curbing
32 17 23 Pavement Markings
32 31 13 Chain Link Fence

DIVISION 33 – UTILITIES

33 10 00 Water Utilities
33 39 00 Sanitary Sewerage Utility Structures
33 40 00 Storm Drainage Utilities
33 40 20 Warning and Tracer Tape

DIVISION 34 – 48

Not Used

END OF TABLE OF CONTENTS

THIS PAGE INTENTIONALLY LEFT BLANK

DOCUMENT 00 65 19.16

WAIVER OF LIEN FORM

The Waiver of Lien Form is included, following this page, as an integral part of the Contract documents. A copy with completed information must be submitted with the second and each succeeding Application for Payment.

WAIVER OF LIEN FORM
Material or Labor

Construction Project Title: _____

General Contractor: _____

Subcontractor/Supplier: _____

General Contractor's previous Application No: _____

General Contractor's previous Application Date: _____

Schedule of Values Line Item No.: _____

DESCRIPTION OF WORK Heading: _____

Total payment Received to Date:
\$ _____

The undersigned Representative of the above Subcontractor/Supplier has been contracted by the above General Contractor to furnish materials, or labor, or both, as included in the approved Schedule of Values under the Line Item No., and DESCRIPTION OF WORK heading indicated above, for the Construction Project listed above.

The undersigned acknowledges receipt of payment, under this Line Item No., and DESCRIPTION OF WORK heading, and hereby waives and releases any and all lien, or claim or right to lien, on the Construction Project listed above, and premises, under the statutes of the State of Rhode Island, relating to Mechanics Liens, on account of materials, or labor, or both, furnished, or which may be furnished, by the undersigned to, or on account of, the above numbered and dated Application and Certificate for Payment.

Signed this month of _____ day of _____, 20__.

(signature)

(company/firm name)

END OF DOCUMENT

DOCUMENT 00 65 19.18

**AFFIDAVIT OF GENERAL CONTRACTOR THAT ALL SUBCONTRACTORS,
SUPPLIERS AND LABORERS HAVE BEEN PAID AND HOLD HARMLESS CLAUSE**

The affidavit is included, following this page, as an integral part of the bid documents, for submittal with all applications for payment.

DOCUMENT 00815

AFFIDAVIT OF GENERAL CONTRACTOR
THAT ALL SUBCONTRACTORS, SUPPLIERS AND LABORERS
HAVE BEEN PAID: AND HOLD HARMLESS CLAUSE

To: ??????????????

The undersigned hereby deposes, says and makes affidavit under oath that he/she is _____ of _____ and further certifies that as of today's date all monies previously advanced pursuant to requisitions of the Contractor in connection with the Project known as Re-Bid of Education Center and Event Pavilion at Roger Williams Park Zoo have been paid to or are being held for and will be paid to the subcontractors, laborers, or suppliers: that there are no further amounts owing to the knowledge of the undersigned other than as set forth in the current requisition, a copy of which is attached hereto, and that only materials, fixtures, and equipment to which undersigned has absolute title have been used in the project. Further, the undersigned **HEREBY HOLDS HARMLESS THE OWNER ROGER WILLIAMS PARK ZOO, AND ALL COMMITTEES, BOARDS, DEPARTMENTS AND AGENCIES THEREUNDER, AND AGREES TO INDEMNIFY SAME FOR ANY ACTION OR SUIT BROUGHT BY ANY SUBCONTRACTOR, LABORER, OR SUPPLIER FOR THE PAYMENT OF ANY SUMS DUE RELATIVE TO The AFORESAID PROJECT.** Said Hold Harmless Clause and Indemnification shall cause the undersigned to shield the Owner and all committees boards, departments and agencies from all attachments, chattel mortgages, and all liens, whatsoever, sought by subcontractors, laborers and/or suppliers for collection of monies allegedly due said parties for work performed on the aforesaid Project.

On the _____ day of _____, 20____, before me
appeared _____, where upon oath said
property executed the foregoing Affidavit as their free act and deed.

NOTARY

My commission expires:

DOCUMENT 00 72 13

GENERAL CONDITIONS

AIA Document A201, General Conditions of the Contract for Construction - 2017 Edition, is included, following this page, as an integral part of the Bidding and Contract Documents. Provisions which are not amended or supplement remain in full force and effect.

THIS PAGE INTENTIONALLY LEFT BLANK

 **AIA[®] Document A201[®] – 2017****General Conditions of the Contract for Construction**

for the following PROJECT:

(Paragraph Deleted)

Roger Williams Park Zoo Education Center and Event Pavilion
1000 Elmwood Avenue, Providence, Rhode Island 02907

THE OWNER:

(Paragraph Deleted)

Roger Williams Park Zoo Education Center and Event Pavilion
1000 Elmwood Avenue, Providence, Rhode Island 02907
Telephone Number: 401-785-3510
Fax Number: 401-941-3988

THE ARCHITECT:

(Paragraph Deleted)

Saccoccio & Associates, Architects
1085 Park Avenue, Cranston, Rhode Island 02910
Tel: 401-942-7970
www.sa-architects.com

TABLE OF ARTICLES

- 1 GENERAL PROVISIONS
- 2 OWNER
- 3 CONTRACTOR
- 4 ARCHITECT
- 5 SUBCONTRACTORS
- 6 CONSTRUCTION BY OWNER OR BY SEPARATE CONTRACTORS
- 7 CHANGES IN THE WORK
- 8 TIME
- 9 PAYMENTS AND COMPLETION
- 10 PROTECTION OF PERSONS AND PROPERTY
- 11 INSURANCE AND BONDS

ADDITIONS AND DELETIONS:

The author of this document has added information needed for its completion. The author may also have revised the text of the original AIA standard form. An *Additions and Deletions Report* that notes added information as well as revisions to the standard form text is available from the author and should be reviewed. A vertical line in the left margin of this document indicates where the author has added necessary information and where the author has added to or deleted from the original AIA text.

This document has important legal consequences. Consultation with an attorney is encouraged with respect to its completion or modification.

For guidance in modifying this document to include supplementary conditions, see AIA Document A503[™], Guide for Supplementary Conditions.

Init.

12 UNCOVERING AND CORRECTION OF WORK

13 MISCELLANEOUS PROVISIONS

14 TERMINATION OR SUSPENSION OF THE CONTRACT

15 CLAIMS AND DISPUTES

[Faint, illegible text, likely bleed-through from the reverse side of the page]

INDEX

(Topics and numbers in bold are Section headings.)

Acceptance of Nonconforming Work

9.6.6, 9.9.3, 12.3

Acceptance of Work

9.6.6, 9.8.2, 9.9.3, 9.10.1, 9.10.3, 12.3

Access to Work

3.16, 6.2.1, 12.1

Accident Prevention

10

Acts and Omissions

3.2, 3.3.2, 3.12.8, 3.18, 4.2.3, 8.3.1, 9.5.1, 10.2.5,
10.2.8, 13.3.2, 14.1, 15.1.2, 15.2

Addenda

1.1.1

Additional Costs, Claims for

3.7.4, 3.7.5, 10.3.2, 15.1.5

Additional Inspections and Testing

9.4.2, 9.8.3, 12.2.1, 13.4

Additional Time, Claims for

3.2.4, 3.7.4, 3.7.5, 3.10.2, 8.3.2, 15.1.6

Administration of the Contract

3.1.3, 4.2, 9.4, 9.5

Advertisement or Invitation to Bid

1.1.1

Aesthetic Effect

4.2.13

Allowances

3.8

Applications for Payment

4.2.5, 7.3.9, 9.2, 9.3, 9.4, 9.5.1, 9.5.4, 9.6.3, 9.7, 9.10

Approvals

2.1.1, 2.3.1, 2.5, 3.1.3, 3.10.2, 3.12.8, 3.12.9,
3.12.10.1, 4.2.7, 9.3.2, 13.4.1

Arbitration

8.3.1, 15.3.2, 15.4

ARCHITECT

4

Architect, Definition of

4.1.1

Architect, Extent of Authority

2.5, 3.12.7, 4.1.2, 4.2, 5.2, 6.3, 7.1.2, 7.3.4, 7.4, 9.2,
9.3.1, 9.4, 9.5, 9.6.3, 9.8, 9.10.1, 9.10.3, 12.1, 12.2.1,
13.4.1, 13.4.2, 14.2.2, 14.2.4, 15.1.4, 15.2.1

Architect, Limitations of Authority and Responsibility

2.1.1, 3.12.4, 3.12.8, 3.12.10, 4.1.2, 4.2.1, 4.2.2,
4.2.3, 4.2.6, 4.2.7, 4.2.10, 4.2.12, 4.2.13, 5.2.1, 7.4,
9.4.2, 9.5.4, 9.6.4, 15.1.4, 15.2

Architect's Additional Services and Expenses

2.5, 12.2.1, 13.4.2, 13.4.3, 14.2.4

Architect's Administration of the Contract

3.1.3, 3.7.4, 15.2, 9.4.1, 9.5

Architect's Approvals

2.5, 3.1.3, 3.5, 3.10.2, 4.2.7

Architect's Authority to Reject Work

3.5, 4.2.6, 12.1.2, 12.2.1

Architect's Copyright

1.1.7, 1.5

Architect's Decisions

3.7.4, 4.2.6, 4.2.7, 4.2.11, 4.2.12, 4.2.13, 4.2.14, 6.3,
7.3.4, 7.3.9, 8.1.3, 8.3.1, 9.2, 9.4.1, 9.5, 9.8.4, 9.9.1,
13.4.2, 15.2

Architect's Inspections

3.7.4, 4.2.2, 4.2.9, 9.4.2, 9.8.3, 9.9.2, 9.10.1, 13.4

Architect's Instructions

3.2.4, 3.3.1, 4.2.6, 4.2.7, 13.4.2

Architect's Interpretations

4.2.11, 4.2.12

Architect's Project Representative

4.2.10

Architect's Relationship with Contractor

1.1.2, 1.5, 2.3.3, 3.1.3, 3.2.2, 3.2.3, 3.2.4, 3.3.1, 3.4.2,
3.5, 3.7.4, 3.7.5, 3.9.2, 3.9.3, 3.10, 3.11, 3.12, 3.16,
3.18, 4.1.2, 4.2, 5.2, 6.2.2, 7, 8.3.1, 9.2, 9.3, 9.4, 9.5,
9.7, 9.8, 9.9, 10.2.6, 10.3, 11.3, 12, 13.3.2, 13.4, 15.2

Architect's Relationship with Subcontractors

1.1.2, 4.2.3, 4.2.4, 4.2.6, 9.6.3, 9.6.4, 11.3

Architect's Representations

9.4.2, 9.5.1, 9.10.1

Architect's Site Visits

3.7.4, 4.2.2, 4.2.9, 9.4.2, 9.5.1, 9.9.2, 9.10.1, 13.4

Asbestos

10.3.1

Attorneys' Fees

3.18.1, 9.6.8, 9.10.2, 10.3.3

Award of Separate Contracts

6.1.1, 6.1.2

Award of Subcontracts and Other Contracts for Portions of the Work

5.2

Basic Definitions

1.1

Bidding Requirements

1.1.1

Binding Dispute Resolution

8.3.1, 9.7, 11.5, 13.1, 15.1.2, 15.1.3, 15.2.1, 15.2.5,
15.2.6.1, 15.3.1, 15.3.2, 15.3.3, 15.4.1

Bonds, Lien

7.3.4.4, 9.6.8, 9.10.2, 9.10.3

Bonds, Performance, and Payment

7.3.4.4, 9.6.7, 9.10.3, 11.1.2, 11.1.3, 11.5

Building Information Models Use and Reliance

1.8

Building Permit

3.7.1

Capitalization

1.3

Certificate of Substantial Completion

9.8.3, 9.8.4, 9.8.5

Init.

Certificates for Payment
 4.2.1, 4.2.5, 4.2.9, 9.3.3, 9.4, 9.5, 9.6.1, 9.6.6, 9.7,
 9.10.1, 9.10.3, 14.1.1.3, 14.2.4, 15.1.4
 Certificates of Inspection, Testing or Approval
 13.4.4
 Certificates of Insurance
 9.10.2
 Change Orders
 1.1.1, 3.4.2, 3.7.4, 3.8.2.3, 3.11, 3.12.8, 4.2.8, 5.2.3,
 7.1.2, 7.1.3, 7.2, 7.3.2, 7.3.7, 7.3.9, 7.3.10, 8.3.1,
 9.3.1.1, 9.10.3, 10.3.2, 11.2, 11.5, 12.1.2
 Change Orders, Definition of
 7.2.1
 CHANGES IN THE WORK
 2.2.2, 3.11, 4.2.8, 7, 7.2.1, 7.3.1, 7.4, 8.3.1, 9.3.1.1,
 11.5
 Claims, Definition of
 15.1.1
 Claims, Notice of
 1.6.2, 15.1.3
 CLAIMS AND DISPUTES
 3.2.4, 6.1.1, 6.3, 7.3.9, 9.3.3, 9.10.4, 10.3.3, 15, 15.4
 Claims and Timely Assertion of Claims
 15.4.1
 Claims for Additional Cost
 3.2.4, 3.3.1, 3.7.4, 7.3.9, 9.5.2, 10.2.5, 10.3.2, 15.1.5
 Claims for Additional Time
 3.2.4, 3.3.1, 3.7.4, 6.1.1, 8.3.2, 9.5.2, 10.3.2, 15.1.6
 Concealed or Unknown Conditions, Claims for
 3.7.4
 Claims for Damages
 3.2.4, 3.18, 8.3.3, 9.5.1, 9.6.7, 10.2.5, 10.3.3, 11.3,
 11.3.2, 14.2.4, 15.1.7
 Claims Subject to Arbitration
 15.4.1
 Cleaning Up
 3.15, 6.3
 Commencement of the Work, Conditions Relating to
 2.2.1, 3.2.2, 3.4.1, 3.7.1, 3.10.1, 3.12.6, 5.2.1, 5.2.3,
 6.2.2, 8.1.2, 8.2.2, 8.3.1, 11.1, 11.2, 15.1.5
 Commencement of the Work, Definition of
 8.1.2
 Communications
 3.9.1, 4.2.4
 Completion, Conditions Relating to
 3.4.1, 3.11, 3.15, 4.2.2, 4.2.9, 8.2, 9.4.2, 9.8, 9.9.1,
 9.10, 12.2, 14.1.2, 15.1.2
 COMPLETION, PAYMENTS AND
 9
 Completion, Substantial
 3.10.1, 4.2.9, 8.1.1, 8.1.3, 8.2.3, 9.4.2, 9.8, 9.9.1,
 9.10.3, 12.2, 15.1.2
 Compliance with Laws
 2.3.2, 3.2.3, 3.6, 3.7, 3.12.10, 3.13, 9.6.4, 10.2.2,
 13.1, 13.3, 13.4.1, 13.4.2, 13.5, 14.1.1, 14.2.1.3,
 15.2.8, 15.4.2, 15.4.3
 Concealed or Unknown Conditions

3.7.4, 4.2.8, 8.3.1, 10.3
 Conditions of the Contract
 1.1.1, 6.1.1, 6.1.4
 Consent, Written
 3.4.2, 3.14.2, 4.1.2, 9.8.5, 9.9.1, 9.10.2, 9.10.3, 13.2,
 15.4.4.2
 Consolidation or Joinder
 15.4.4
 CONSTRUCTION BY OWNER OR BY
 SEPARATE CONTRACTORS
 1.1.4, 6
 Construction Change Directive, Definition of
 7.3.1
 Construction Change Directives
 1.1.1, 3.4.2, 3.11, 3.12.8, 4.2.8, 7.1.1, 7.1.2, 7.1.3,
 7.3, 9.3.1.1
 Construction Schedules, Contractor's
 3.10, 3.11, 3.12.1, 3.12.2, 6.1.3, 15.1.6.2
 Contingent Assignment of Subcontracts
 5.4, 14.2.2.2
 Continuing Contract Performance
 15.1.4
 Contract, Definition of
 1.1.2
 CONTRACT, TERMINATION OR SUSPENSION
 OF THE
 5.4.1.1, 5.4.2, 11.5, 14
 Contract Administration
 3.1.3, 4, 9.4, 9.5
 Contract Award and Execution, Conditions Relating
 to
 3.7.1, 3.10, 5.2, 6.1
 Contract Documents, Copies Furnished and Use of
 1.5.2, 2.3.6, 5.3
 Contract Documents, Definition of
 1.1.1
 Contract Sum
 2.2.2, 2.2.4, 3.7.4, 3.7.5, 3.8, 3.10.2, 5.2.3, 7.3, 7.4,
 9.1, 9.2, 9.4.2, 9.5.1.4, 9.6.7, 9.7, 10.3.2, 11.5, 12.1.2,
 12.3, 14.2.4, 14.3.2, 15.1.4.2, 15.1.5, 15.2.5
 Contract Sum, Definition of
 9.1
 Contract Time
 1.1.4, 2.2.1, 2.2.2, 3.7.4, 3.7.5, 3.10.2, 5.2.3, 6.1.5,
 7.2.1.3, 7.3.1, 7.3.5, 7.3.6, 7, 7, 7.3.10, 7.4, 8.1.1,
 8.2.1, 8.2.3, 8.3.1, 9.5.1, 9.7, 10.3.2, 12.1.1, 12.1.2,
 14.3.2, 15.1.4.2, 15.1.6.1, 15.2.5
 Contract Time, Definition of
 8.1.1
 CONTRACTOR
 3
 Contractor, Definition of
 3.1, 6.1.2
 Contractor's Construction and Submittal Schedules
 3.10, 3.12.1, 3.12.2, 4.2.3, 6.1.3, 15.1.6.2
 Contractor's Employees

2.2.4, 3.3.2, 3.4.3, 3.8.1, 3.9, 3.18.2, 4.2.3, 4.2.6,
10.2, 10.3, 11.3, 14.1, 14.2.1.1
Contractor's Liability Insurance
11.1
Contractor's Relationship with Separate Contractors
and Owner's Forces
3.12.5, 3.14.2, 4.2.4, 6, 11.3, 12.2.4
Contractor's Relationship with Subcontractors
1.2.2, 2.2.4, 3.3.2, 3.18.1, 3.18.2, 4.2.4, 5, 9.6.2,
9.6.7, 9.10.2, 11.2, 11.3, 11.4
Contractor's Relationship with the Architect
1.1.2, 1.5, 2.3.3, 3.1.3, 3.2.2, 3.2.3, 3.2.4, 3.3.1, 3.4.2,
3.5.1, 3.7.4, 3.10, 3.11, 3.12, 3.16, 3.18, 4.2, 5.2,
6.2.2, 7, 8.3.1, 9.2, 9.3, 9.4, 9.5, 9.7, 9.8, 9.9, 10.2.6,
10.3, 11.3, 12, 13.4, 15.1.3, 15.2.1
Contractor's Representations
3.2.1, 3.2.2, 3.5, 3.12.6, 6.2.2, 8.2.1, 9.3.3, 9.8.2
Contractor's Responsibility for Those Performing the
Work
3.3.2, 3.18, 5.3, 6.1.3, 6.2, 9.5.1, 10.2.8
Contractor's Review of Contract Documents
3.2
Contractor's Right to Stop the Work
2.2.2, 9.7
Contractor's Right to Terminate the Contract
14.1
Contractor's Submittals
3.10, 3.11, 3.12, 4.2.7, 5.2.1, 5.2.3, 9.2, 9.3, 9.8.2,
9.8.3, 9.9.1, 9.10.2, 9.10.3
Contractor's Superintendent
3.9, 10.2.6
Contractor's Supervision and Construction
Procedures
1.2.2, 3.3, 3.4, 3.12.10, 4.2.2, 4.2.7, 6.1.3, 6.2.4,
7.1.3, 7.3.4, 7.3.6, 8.2, 10, 12, 14, 15.1.4
Coordination and Correlation
1.2, 3.2.1, 3.3.1, 3.10, 3.12.6, 6.1.3, 6.2.1
Copies Furnished of Drawings and Specifications
1.5, 2.3.6, 3.11
Copyrights
1.5, 3.17
Correction of Work
2.5, 3.7.3, 9.4.2, 9.8.2, 9.8.3, 9.9.1, 12.1.2, 12.2, 12.3,
15.1.3.1, 15.1.3.2, 15.2.1
Correlation and Intent of the Contract Documents
1.2
Cost, Definition of
7.3.4
Costs
2.5, 3.2.4, 3.7.3, 3.8.2, 3.15.2, 5.4.2, 6.1.1, 6.2.3,
7.3.3.3, 7.3.4, 7.3.8, 7.3.9, 9.10.2, 10.3.2, 10.3.6,
11.2, 12.1.2, 12.2.1, 12.2.4, 13.4, 14
Cutting and Patching
3.14, 6.2.5
Damage to Construction of Owner or Separate
Contractors
3.14.2, 6.2.4, 10.2.1.2, 10.2.5, 10.4, 12.2.4

Damage to the Work
3.14.2, 9.9.1, 10.2.1.2, 10.2.5, 10.4, 12.2.4
Damages, Claims for
3.2.4, 3.18, 6.1.1, 8.3.3, 9.5.1, 9.6.7, 10.3.3, 11.3.2,
11.3, 14.2.4, 15.1.7
Damages for Delay
6.2.3, 8.3.3, 9.5.1.6, 9.7, 10.3.2, 14.3.2
Date of Commencement of the Work, Definition of
8.1.2
Date of Substantial Completion, Definition of
8.1.3
Day, Definition of
8.1.4
Decisions of the Architect
3.7.4, 4.2.6, 4.2.7, 4.2.11, 4.2.12, 4.2.13, 6.3, 7.3.4,
7.3.9, 8.1.3, 8.3.1, 9.2, 9.4, 9.5.1, 9.8.4, 9.9.1, 13.4.2,
14.2.2, 14.2.4, 15.1, 15.2
Decisions to Withhold Certification
9.4.1, 9.5, 9.7, 14.1.1.3
Defective or Nonconforming Work, Acceptance,
Rejection and Correction of
2.5, 3.5, 4.2.6, 6.2.3, 9.5.1, 9.5.3, 9.6.6, 9.8.2, 9.9.3,
9.10.4, 12.2.1
Definitions
1.1, 2.1.1, 3.1.1, 3.5, 3.12.1, 3.12.2, 3.12.3, 4.1.1, 5.1,
6.1.2, 7.2.1, 7.3.1, 8.1, 9.1, 9.8.1, 15.1.1
Delays and Extensions of Time
3.2, 3.7.4, 5.2.3, 7.2.1, 7.3.1, 7.4, 8.3, 9.5.1, 9.7,
10.3.2, 10.4, 14.3.2, 15.1.6, 15.2.5
Digital Data Use and Transmission
1.7
Disputes
6.3, 7.3.9, 15.1, 15.2
Documents and Samples at the Site
3.11
Drawings, Definition of
1.1.5
Drawings and Specifications, Use and Ownership of
3.11
Effective Date of Insurance
8.2.2
Emergencies
10.4, 14.1.1.2, 15.1.5
Employees, Contractor's
3.3.2, 3.4.3, 3.8.1, 3.9, 3.18.2, 4.2.3, 4.2.6, 10.2,
10.3.3, 11.3, 14.1, 14.2.1.1
Equipment, Labor, or Materials
1.1.3, 1.1.6, 3.4, 3.5, 3.8.2, 3.8.3, 3.12, 3.13, 3.15.1,
4.2.6, 4.2.7, 5.2.1, 6.2.1, 7.3.4, 9.3.2, 9.3.3, 9.5.1.3,
9.10.2, 10.2.1, 10.2.4, 14.2.1.1, 14.2.1.2
Execution and Progress of the Work
1.1.3, 1.2.1, 1.2.2, 2.3.4, 2.3.6, 3.1, 3.3.1, 3.4.1, 3.7.1,
3.10.1, 3.12, 3.14, 4.2, 6.2.2, 7.1.3, 7.3.6, 8.2, 9.5.1,
9.9.1, 10.2, 10.3, 12.1, 12.2, 14.2, 14.3.1, 15.1.4
Extensions of Time
3.2.4, 3.7.4, 5.2.3, 7.2.1, 7.3, 7.4, 9.5.1, 9.7, 10.3.2,
10.4, 14.3, 15.1.6, 15.2.5

Failure of Payment
 9.5.1.3, 9.7, 9.10.2, 13.5, 14.1.1.3, 14.2.1.2
 Faulty Work
 (See Defective or Nonconforming Work)
 Final Completion and Final Payment
 4.2.1, 4.2.9, 9.8.2, 9.10, 12.3, 14.2.4, 14.4.3
 Financial Arrangements, Owner's
 2.2.1, 13.2.2, 14.1.1.4
GENERAL PROVISIONS
 1
 Governing Law
 13.1
 Guarantees (See Warranty)
 Hazardous Materials and Substances
 10.2.4, 10.3
 Identification of Subcontractors and Suppliers
 5.2.1
 Indemnification
 3.17, 3.18, 9.6.8, 9.10.2, 10.3.3, 11.3
 Information and Services Required of the Owner
 2.1.2, 2.2, 2.3, 3.2.2, 3.12.10.1, 6.1.3, 6.1.4, 6.2.5,
 9.6.1, 9.9.2, 9.10.3, 10.3.3, 11.2, 13.4.1, 13.4.2,
 14.1.1.4, 14.1.4, 15.1.4
 Initial Decision
 15.2
 Initial Decision Maker, Definition of
 1.1.8
 Initial Decision Maker, Decisions
 14.2.4, 15.1.4.2, 15.2.1, 15.2.2, 15.2.3, 15.2.4, 15.2.5
 Initial Decision Maker, Extent of Authority
 14.2.4, 15.1.4.2, 15.2.1, 15.2.2, 15.2.3, 15.2.4, 15.2.5
 Injury or Damage to Person or Property
 10.2.8, 10.4
 Inspections
 3.1.3, 3.3.3, 3.7.1, 4.2.2, 4.2.6, 4.2.9, 9.4.2, 9.8.3,
 9.9.2, 9.10.1, 12.2.1, 13.4
 Instructions to Bidders
 1.1.1
 Instructions to the Contractor
 3.2.4, 3.3.1, 3.8.1, 5.2.1, 7, 8.2.2, 12, 13.4.2
 Instruments of Service, Definition of
 1.1.7
 Insurance
 6.1.1, 7.3.4, 8.2.2, 9.3.2, 9.8.4, 9.9.1, 9.10.2, 10.2.5,
 11
 Insurance, Notice of Cancellation or Expiration
 11.1.4, 11.2.3
 Insurance, Contractor's Liability
 11.1
 Insurance, Effective Date of
 8.2.2, 14.4.2
 Insurance, Owner's Liability
 11.2
 Insurance, Property
 10.2.5, 11.2, 11.4, 11.5
 Insurance, Stored Materials
 9.3.2

INSURANCE AND BONDS
 11
 Insurance Companies, Consent to Partial Occupancy
 9.9.1
 Insured loss, Adjustment and Settlement of
 11.5
 Intent of the Contract Documents
 1.2.1, 4.2.7, 4.2.12, 4.2.13
 Interest
 13.5
 Interpretation
 1.1.8, 1.2.3, 1.4, 4.1.1, 5.1, 6.1.2, 15.1.1
 Interpretations, Written
 4.2.11, 4.2.12
 Judgment on Final Award
 15.4.2
 Labor and Materials, Equipment
 1.1.3, 1.1.6, 3.4, 3.5, 3.8.2, 3.8.3, 3.12, 3.13, 3.15.1,
 5.2.1, 6.2.1, 7.3.4, 9.3.2, 9.3.3, 9.5.1.3, 9.10.2, 10.2.1,
 10.2.4, 14.2.1.1, 14.2.1.2
 Labor Disputes
 8.3.1
 Laws and Regulations
 1.5, 2.3.2, 3.2.3, 3.2.4, 3.6, 3.7, 3.12.10, 3.13, 9.6.4,
 9.9.1, 10.2.2, 13.1, 13.3.1, 13.4.2, 13.5, 14, 15.2.8,
 15.4
 Liens
 2.1.2, 9.3.1, 9.3.3, 9.6.8, 9.10.2, 9.10.4, 15.2.8
 Limitations, Statutes of
 12.2.5, 15.1.2, 15.4.1.1
 Limitations of Liability
 3.2.2, 3.5, 3.12.10, 3.12.10.1, 3.17, 3.18.1, 4.2.6,
 4.2.7, 6.2.2, 9.4.2, 9.6.4, 9.6.7, 9.6.8, 10.2.5, 10.3.3,
 11.3, 12.2.5, 13.3.1
 Limitations of Time
 2.1.2, 2.2, 2.5, 3.2.2, 3.10, 3.11, 3.12.5, 3.15.1, 4.2.7,
 5.2, 5.3, 5.4.1, 6.2.4, 7.3, 7.4, 8.2, 9.2, 9.3.1, 9.3.3,
 9.4.1, 9.5, 9.6, 9.7, 9.8, 9.9, 9.10, 12.2, 13.4, 14, 15,
 15.1.2, 15.1.3, 15.1.5
 Materials, Hazardous
 10.2.4, 10.3
 Materials, Labor, Equipment and
 1.1.3, 1.1.6, 3.4.1, 3.5, 3.8.2, 3.8.3, 3.12, 3.13, 3.15.1,
 5.2.1, 6.2.1, 7.3.4, 9.3.2, 9.3.3, 9.5.1.3, 9.10.2,
 10.2.1.2, 10.2.4, 14.2.1.1, 14.2.1.2
 Means, Methods, Techniques, Sequences and
 Procedures of Construction
 3.3.1, 3.12.10, 4.2.2, 4.2.7, 9.4.2
 Mechanic's Lien
 2.1.2, 9.3.1, 9.3.3, 9.6.8, 9.10.2, 9.10.4, 15.2.8
 Mediation
 8.3.1, 15.1.3.2, 15.2.1, 15.2.5, 15.2.6, 15.3, 15.4.1,
 15.4.1.1
 Minor Changes in the Work
 1.1.1, 3.4.2, 3.12.8, 4.2.8, 7.1, 7.4
MISCELLANEOUS PROVISIONS
 13

Modifications, Definition of
 1.1.1
 Modifications to the Contract
 1.1.1, 1.1.2, 2.5, 3.11, 4.1.2, 4.2.1, 5.2.3, 7, 8.3.1, 9.7, 10.3.2
 Mutual Responsibility
 6.2
 Nonconforming Work, Acceptance of
 9.6.6, 9.9.3, 12.3
 Nonconforming Work, Rejection and Correction of
 2.4, 2.5, 3.5, 4.2.6, 6.2.4, 9.5.1, 9.8.2, 9.9.3, 9.10.4, 12.2
 Notice
 1.6, 1.6.1, 1.6.2, 2.1.2, 2.2.2., 2.2.3, 2.2.4, 2.5, 3.2.4, 3.3.1, 3.7.4, 3.7.5, 3.9.2, 3.12.9, 3.12.10, 5.2.1, 7.4, 8.2.2, 9.6.8, 9.7, 9.10.1, 10.2.8, 10.3.2, 11.5, 12.2.2.1, 13.4.1, 13.4.2, 14.1, 14.2.2, 14.4.2, 15.1.3, 15.1.5, 15.1.6, 15.4.1
 Notice of Cancellation or Expiration of Insurance
 11.1.4, 11.2.3
 Notice of Claims
 1.6.2, 2.1.2, 3.7.4, 9.6.8, 10.2.8, 15.1.3, 15.1.5, 15.1.6, 15.2.8, 15.3.2, 15.4.1
 Notice of Testing and Inspections
 13.4.1, 13.4.2
 Observations, Contractor's
 3.2, 3.7.4
 Occupancy
 2.3.1, 9.6.6, 9.8
 Orders, Written
 1.1.1, 2.4, 3.9.2, 7, 8.2.2, 11.5, 12.1, 12.2.2.1, 13.4.2, 14.3.1
 OWNER
 2
 Owner, Definition of
 2.1.1
 Owner, Evidence of Financial Arrangements
 2.2, 13.2.2, 14.1.1.4
 Owner, Information and Services Required of the
 2.1.2, 2.2, 2.3, 3.2.2, 3.12.10, 6.1.3, 6.1.4, 6.2.5, 9.3.2, 9.6.1, 9.6.4, 9.9.2, 9.10.3, 10.3.3, 11.2, 13.4.1, 13.4.2, 14.1.1.4, 14.1.4, 15.1.4
 Owner's Authority
 1.5, 2.1.1, 2.3.32.4, 2.5, 3.4.2, 3.8.1, 3.12.10, 3.14.2, 4.1.2, 4.2.4, 4.2.9, 5.2.1, 5.2.4, 5.4.1, 6.1, 6.3, 7.2.1, 7.3.1, 8.2.2, 8.3.1, 9.3.2, 9.5.1, 9.6.4, 9.9.1, 9.10.2, 10.3.2, 11.4, 11.5, 12.2.2, 12.3, 13.2.2, 14.3, 14.4, 15.2.7
 Owner's Insurance
 11.2
 Owner's Relationship with Subcontractors
 1.1.2, 5.2, 5.3, 5.4, 9.6.4, 9.10.2, 14.2.2
 Owner's Right to Carry Out the Work
 2.5, 14.2.2
 Owner's Right to Clean Up
 6.3
 Owner's Right to Perform Construction and to Award

Separate Contracts
 6.1
 Owner's Right to Stop the Work
 2.4
 Owner's Right to Suspend the Work
 14.3
 Owner's Right to Terminate the Contract
 14.2, 14.4
 Ownership and Use of Drawings, Specifications and Other Instruments of Service
 1.1.1, 1.1.6, 1.1.7, 1.5, 2.3.6, 3.2.2, 3.11, 3.17, 4.2.12, 5.3
 Partial Occupancy or Use
 9.6.6, 9.9
 Patching, Cutting and
 3.14, 6.2.5
 Patents
 3.17
 Payment, Applications for
 4.2.5, 7.3.9, 9.2, 9.3, 9.4, 9.5, 9.6.3, 9.7, 9.8.5, 9.10.1, 14.2.3, 14.2.4, 14.4.3
 Payment, Certificates for
 4.2.5, 4.2.9, 9.3.3, 9.4, 9.5, 9.6.1, 9.6.6, 9.7, 9.10.1, 9.10.3, 14.1.1.3, 14.2.4
 Payment, Failure of
 9.5.1.3, 9.7, 9.10.2, 13.5, 14.1.1.3, 14.2.1.2
 Payment, Final
 4.2.1, 4.2.9, 9.10, 12.3, 14.2.4, 14.4.3
 Payment Bond, Performance Bond and
 7.3.4.4, 9.6.7, 9.10.3, 11.1.2
 Payments, Progress
 9.3, 9.6, 9.8.5, 9.10.3, 14.2.3, 15.1.4
 PAYMENTS AND COMPLETION
 9
 Payments to Subcontractors
 5.4.2, 9.5.1.3, 9.6.2, 9.6.3, 9.6.4, 9.6.7, 14.2.1.2
 PCB
 10.3.1
 Performance Bond and Payment Bond
 7.3.4.4, 9.6.7, 9.10.3, 11.1.2
 Permits, Fees, Notices and Compliance with Laws
 2.3.1, 3.7, 3.13, 7.3.4.4, 10.2.2
 PERSONS AND PROPERTY, PROTECTION OF
 10
 Polychlorinated Biphenyl
 10.3.1
 Product Data, Definition of
 3.12.2
 Product Data and Samples, Shop Drawings
 3.11, 3.12, 4.2.7
 Progress and Completion
 4.2.2, 8.2, 9.8, 9.9.1, 14.1.4, 15.1.4
 Progress Payments
 9.3, 9.6, 9.8.5, 9.10.3, 14.2.3, 15.1.4
 Project, Definition of
 1.1.4
 Project Representatives

Init.

4.2.10
 Property Insurance
 10.2.5, 11.2
 Proposal Requirements
 1.1.1
PROTECTION OF PERSONS AND PROPERTY
 10
 Regulations and Laws
 1.5, 2.3.2, 3.2.3, 3.6, 3.7, 3.12.10, 3.13, 9.6.4, 9.9.1,
 10.2.2, 13.1, 13.3, 13.4.1, 13.4.2, 13.5, 14, 15.2.8,
 15.4
 Rejection of Work
 4.2.6, 12.2.1
 Releases and Waivers of Liens
 9.3.1, 9.10.2
 Representations
 3.2.1, 3.5, 3.12.6, 8.2.1, 9.3.3, 9.4.2, 9.5.1, 9.10.1
 Representatives
 2.1.1, 3.1.1, 3.9, 4.1.1, 4.2.10, 13.2.1
 Responsibility for Those Performing the Work
 3.3.2, 3.18, 4.2.2, 4.2.3, 5.3, 6.1.3, 6.2, 6.3, 9.5.1, 10
 Retainage
 9.3.1, 9.6.2, 9.8.5, 9.9.1, 9.10.2, 9.10.3
 Review of Contract Documents and Field Conditions
 by Contractor
 3.2, 3.12.7, 6.1.3
 Review of Contractor's Submittals by Owner and
 Architect
 3.10.1, 3.10.2, 3.11, 3.12, 4.2, 5.2, 6.1.3, 9.2, 9.8.2
 Review of Shop Drawings, Product Data and
 Samples by Contractor
 3.12
 Rights and Remedies
 1.1.2, 2.4, 2.5, 3.5, 3.7.4, 3.15.2, 4.2.6, 5.3, 5.4, 6.1,
 6.3, 7.3.1, 8.3, 9.5.1, 9.7, 10.2.5, 10.3, 12.2.1, 12.2.2,
 12.2.4, 13.3, 14, 15.4
 Royalties, Patents and Copyrights
 3.17
 Rules and Notices for Arbitration
 15.4.1
 Safety of Persons and Property
 10.2, 10.4
 Safety Precautions and Programs
 3.3.1, 4.2.2, 4.2.7, 5.3, 10.1, 10.2, 10.4
 Samples, Definition of
 3.12.3
 Samples, Shop Drawings, Product Data and
 3.11, 3.12, 4.2.7
 Samples at the Site, Documents and
 3.11
 Schedule of Values
 9.2, 9.3.1
 Schedules, Construction
 3.10, 3.12.1, 3.12.2, 6.1.3, 15.1.6.2
 Separate Contracts and Contractors
 1.1.4, 3.12.5, 3.14.2, 4.2.4, 4.2.7, 6, 8.3.1, 12.1.2
 Separate Contractors, Definition of

6.1.1
 Shop Drawings, Definition of
 3.12.1
 Shop Drawings, Product Data and Samples
 3.11, 3.12, 4.2.7
 Site, Use of
 3.13, 6.1.1, 6.2.1
 Site Inspections
 3.2.2, 3.3.3, 3.7.1, 3.7.4, 4.2, 9.9.2, 9.4.2, 9.10.1, 13.4
 Site Visits, Architect's
 3.7.4, 4.2.2, 4.2.9, 9.4.2, 9.5.1, 9.9.2, 9.10.1, 13.4
 Special Inspections and Testing
 4.2.6, 12.2.1, 13.4
 Specifications, Definition of
 1.1.6
 Specifications
 1.1.1, 1.1.6, 1.2.2, 1.5, 3.12.10, 3.17, 4.2.14
 Statute of Limitations
 15.1.2, 15.4.1.1
 Stopping the Work
 2.2.2, 2.4, 9.7, 10.3, 14.1
 Stored Materials
 6.2.1, 9.3.2, 10.2.1.2, 10.2.4
 Subcontractor, Definition of
 5.1.1
SUBCONTRACTORS
 5
 Subcontractors, Work by
 1.2.2, 3.3.2, 3.12.1, 3.18, 4.2.3, 5.2.3, 5.3, 5.4,
 9.3.1.2, 9.6.7
 Subcontractual Relations
 5.3, 5.4, 9.3.1.2, 9.6, 9.10, 10.2.1, 14.1, 14.2.1
 Submittals
 3.10, 3.11, 3.12, 4.2.7, 5.2.1, 5.2.3, 7.3.4, 9.2, 9.3,
 9.8, 9.9.1, 9.10.2, 9.10.3
 Submittal Schedule
 3.10.2, 3.12.5, 4.2.7
 Subrogation, Waivers of
 6.1.1, 11.3
 Substances, Hazardous
 10.3
 Substantial Completion
 4.2.9, 8.1.1, 8.1.3, 8.2.3, 9.4.2, 9.8, 9.9.1, 9.10.3,
 12.2, 15.1.2
 Substantial Completion, Definition of
 9.8.1
 Substitution of Subcontractors
 5.2.3, 5.2.4
 Substitution of Architect
 2.3.3
 Substitutions of Materials
 3.4.2, 3.5, 7.3.8
 Sub-subcontractor, Definition of
 5.1.2
 Subsurface Conditions
 3.7.4
 Successors and Assigns

13.2
 Superintendent
 3.9, 10.2.6
 Supervision and Construction Procedures
 1.2.2, 3.3, 3.4, 3.12.10, 4.2.2, 4.2.7, 6.1.3, 6.2.4,
 7.1.3, 7.3.4, 8.2, 8.3.1, 9.4.2, 10, 12, 14, 15.1.4
 Suppliers
 1.5, 3.12.1, 4.2.4, 4.2.6, 5.2.1, 9.3, 9.4.2, 9.5.4, 9.6,
 9.10.5, 14.2.1
 Surety
 5.4.1.2, 9.6.8, 9.8.5, 9.10.2, 9.10.3, 11.1.2, 14.2.2,
 15.2.7
 Surety, Consent of
 9.8.5, 9.10.2, 9.10.3
 Surveys
 1.1.7, 2.3.4
 Suspension by the Owner for Convenience
 14.3
 Suspension of the Work
 3.7.5, 5.4.2, 14.3
 Suspension or Termination of the Contract
 5.4.1.1, 14
 Taxes
 3.6, 3.8.2.1, 7.3.4.4
 Termination by the Contractor
 14.1, 15.1.7
 Termination by the Owner for Cause
 5.4.1.1, 14.2, 15.1.7
 Termination by the Owner for Convenience
 14.4
 Termination of the Architect
 2.3.3
 Termination of the Contractor Employment
 14.2.2

TERMINATION OR SUSPENSION OF THE CONTRACT
 14
 Tests and Inspections
 3.1.3, 3.3.3, 3.7.1, 4.2.2, 4.2.6, 4.2.9, 9.4.2, 9.8.3,
 9.9.2, 9.10.1, 10.3.2, 12.2.1, 13.4
TIME
 8
 Time, Delays and Extensions of
 3.2.4, 3.7.4, 5.2.3, 7.2.1, 7.3.1, 7.4, 8.3, 9.5.1, 9.7,
 10.3.2, 10.4, 14.3.2, 15.1.6, 15.2.5
 Time Limits

2.1.2, 2.2, 2.5, 3.2.2, 3.10, 3.11, 3.12.5, 3.15.1, 4.2,
 5.2, 5.3, 5.4, 6.2.4, 7.3, 7.4, 8.2, 9.2, 9.3.1, 9.3.3,
 9.4.1, 9.5, 9.6, 9.7, 9.8, 9.9, 9.10, 12.2, 13.4, 14,
 15.1.2, 15.1.3, 15.4
 Time Limits on Claims
 3.7.4, 10.2.8, 15.1.2, 15.1.3
 Title to Work
 9.3.2, 9.3.3
UNCOVERING AND CORRECTION OF WORK
 12
 Uncovering of Work
 12.1
 Unforeseen Conditions, Concealed or Unknown
 3.7.4, 8.3.1, 10.3
 Unit Prices
 7.3.3.2, 9.1.2
 Use of Documents
 1.1.1, 1.5, 2.3.6, 3.12.6, 5.3
 Use of Site
 3.13, 6.1.1, 6.2.1
 Values, Schedule of
 9.2, 9.3.1
 Waiver of Claims by the Architect
 13.3.2
 Waiver of Claims by the Contractor
 9.10.5, 13.3.2, 15.1.7
 Waiver of Claims by the Owner
 9.9.3, 9.10.3, 9.10.4, 12.2.2.1, 13.3.2, 14.2.4, 15.1.7
 Waiver of Consequential Damages
 14.2.4, 15.1.7
 Waiver of Liens
 9.3, 9.10.2, 9.10.4
 Waivers of Subrogation
 6.1.1, 11.3
 Warranty
 3.5, 4.2.9, 9.3.3, 9.8.4, 9.9.1, 9.10.2, 9.10.4, 12.2.2,
 15.1.2
 Weather Delays
 8.3, 15.1.6.2
 Work, Definition of
 1.1.3
 Written Consent
 1.5.2, 3.4.2, 3.7.4, 3.12.8, 3.14.2, 4.1.2, 9.3.2, 9.10.3,
 13.2, 13.3.2, 15.4.4.2
 Written Interpretations
 4.2.11, 4.2.12
 Written Orders
 1.1.1, 2.4, 3.9, 7, 8.2.2, 12.1, 12.2, 13.4.2, 14.3.1

ARTICLE 1 GENERAL PROVISIONS

§ 1.1 Basic Definitions

§ 1.1.1 The Contract Documents

The Contract Documents consist of the Agreement between the Owner and Contractor (hereinafter, the Agreement), Conditions of the Contract (General, Supplementary and other Conditions), Drawings, Specifications, Addenda issued prior to execution of the Contract, other documents listed in the Agreement, and Modifications issued after execution of the Contract. A Modification is (1) a written amendment to the Contract signed by both parties, (2) a Change Order, (3) a Construction Change Directive, or (4) a written order for a minor change in the Work issued by the Architect. Unless specifically enumerated in the Agreement, the Contract Documents include the advertisement or invitation to bid, Instructions to Bidders, sample forms, information furnished by the Owner in anticipation of receiving bids or proposals, the Contractor's bid or proposal, and Addenda relating to those documents.

In the event of any conflict among the Contract Documents, the Documents shall be construed according to the following priorities:

Highest Priority: Modifications

Second Priority: Agreement

Third Priority: Addenda –later date to take precedence

Fourth Priority: Supplementary General Conditions (if any)

Fifth Priority: General Conditions

Sixth Priority: Specifications and Drawings; Specifications with respect to quality and general performance of the Work and Drawings with respect to quantity of materials and general location of the Work. Detail drawings shall take precedence over small-scale drawings.

Seventh Priority: Request for Proposal.

§ 1.1.2 The Contract

The Contract Documents form the Contract for Construction. The Contract represents the entire and integrated agreement between the parties hereto and supersedes prior negotiations, representations, or agreements, either written or oral. The Contract may be amended or modified only by a Modification. The Contract Documents shall not be construed to create a contractual relationship of any kind (1) between the Contractor and the Architect or the Architect's consultants, (2) between the Owner and a Subcontractor or a Sub-subcontractor, (3) between the Owner and the Architect or the Architect's consultants, or (4) between any persons or entities other than the Owner and the Contractor. The Architect shall, however, be entitled to performance and enforcement of obligations under the Contract intended to facilitate performance of the Architect's duties.

§ 1.1.3 The Work

The term "Work" means the construction and services required by the Contract Documents, whether completed or partially completed, and includes all other labor, materials, equipment, and services provided or to be provided by the Contractor to fulfill the Contractor's obligations. The Work may constitute the whole or a part of the Project.

§ 1.1.4 The Project

The Project is the total construction of which the Work performed under the Contract Documents may be the whole or a part and which may include construction by the Owner and by Separate Contractors.

§ 1.1.5 The Drawings

The Drawings are the graphic and pictorial portions of the Contract Documents showing the design, location and dimensions of the Work, generally including plans, elevations, sections, details, schedules, and diagrams.

§ 1.1.6 The Specifications

The Specifications are that portion of the Contract Documents consisting of the written requirements for materials, equipment, systems, standards and workmanship for the Work, and performance of related services.

§ 1.1.7 Instruments of Service

Instruments of Service are representations, in any medium of expression now known or later developed, of the tangible and intangible creative work performed by the Architect and the Architect's consultants under their

respective professional services agreements. Instruments of Service may include, without limitation, studies, surveys, models, sketches, drawings, specifications, and other similar materials.

§ 1.1.8 Initial Decision Maker

The Initial Decision Maker is the person identified in the Agreement to render initial decisions on Claims in accordance with Section 15.2. The Initial Decision Maker shall not show partiality to the Owner or Contractor and shall not be liable for results of interpretations or decisions rendered in good faith.

§ 1.2 Correlation and Intent of the Contract Documents

§ 1.2.1 The intent of the Contract Documents is to include all items necessary for the proper execution and completion of the Work by the Contractor. The Contract Documents are complementary, and what is required by one shall be as binding as if required by all; performance by the Contractor shall be required only to the extent consistent with the Contract Documents and reasonably inferable from them as being necessary to produce the indicated results. All Work mentioned or indicated in the Contract Documents shall be performed by the Contractor as part of this Contract unless it is specifically indicated in the Contract Documents that such Work is to be done by others.

Should the Drawings or the Specifications disagree in themselves or with each other, the Contractor shall provide the better quality or greater quantity of Work unless otherwise directed by written addendum to the Contract.

§ 1.2.1.1 The invalidity of any provision of the Contract Documents shall not invalidate the Contract or its remaining provisions. If it is determined that any provision of the Contract Documents violates any law, or is otherwise invalid or unenforceable, then that provision shall be revised to the extent necessary to make that provision legal and enforceable. In such case the Contract Documents shall be construed, to the fullest extent permitted by law, to give effect to the parties' intentions and purposes in executing the Contract.

§ 1.2.2 Organization of the Specifications into divisions, sections and articles, and arrangement of Drawings shall not control the Contractor in dividing the Work among Subcontractors or in establishing the extent of Work to be performed by any trade. The Contractor and all Subcontractors shall refer to all of the Drawings, including those showing primarily the Work of the mechanical, electrical and other specialized trades, and to all of the Sections of the Specifications, and shall perform all Work reasonably inferable therefrom as being necessary to produce the indicated results.

§ 1.2.3 Unless otherwise stated in the Contract Documents, words that have well-known technical or construction industry meanings are used in the Contract Documents in accordance with such recognized meanings.

§ 1.2.4 All indications or notations which apply to one of a number of similar situations, materials or processes shall be deemed to apply to all such situations, materials or processes wherever they appear in the Work, except where a contrary result is clearly indicated by the Contract Documents.

§ 1.2.5 Where codes, standards, requirements and publications of public and private bodies are referred to in the Specifications, references shall be understood to be to the latest revision prior to the date of receiving bids, except where otherwise indicated.

§ 1.2.6 Where no explicit quality or standards for materials or workmanship are established for Work, such Work is to be of good quality for the intended use and consistent with the quality of the surrounding Work and of the construction of the Project generally.

§ 1.2.7 All manufactured articles, materials, and equipment shall be applied, installed, connected, erected, used, cleaned, and conditioned in accordance with the manufacturer's written or printed directions and instructions unless otherwise indicated in the Contract Documents.

§ 1.2.8 All drawings are diagrammatic and indicate general arrangement of systems and equipment, except when specifically dimensioned or detailed. For exact locations of building elements, refer to dimensioned drawings. Field measurements take precedence over dimensioned drawings. Intention is to show size, capacity, approximate location, direction and general relationship of one work phase to another, but not exact detail or arrangement. Installation of all systems and equipment is subject to clarification as indicated in reviewed shop drawings and field coordination drawings.

Init.

Dimensions indicated on contract drawings are limiting dimensions. Do not use equipment exceeding dimensions indicated or equipment or arrangements that reduce required clearances or exceed specified maximum dimensions.

§ 1.2.9 The Mechanical, Plumbing, Electrical and Fire Protection Drawings are diagrammatic only, and are not intended to show the alignment, physical locations or configurations of such Work. Such Work shall be installed without additional cost to the Owner to clear all obstructions, permit proper clearances for the Work of other trades, and present an orderly appearance where exposed. Prior to beginning such Work, the Contractor shall prepare coordination drawings showing the exact alignment, physical location and configuration of the Mechanical, Plumbing, Electrical and Fire Protection installations and demonstrating to the Contractor's satisfaction that the installations will comply with the preceding sentence. A copy of the drawings shall be submitted to the Architect, and the Contractor shall revise and resubmit the drawings if so directed by the Architect.

§ 1.2.10 Exact locations of fixtures and outlets shall be obtained from the Architect as provided in subparagraph 3.2.5 before the Work is roughed in; Work installed without such information from the Architect shall be relocated at the Contractor's expense.

§ 1.2.11 Test boring or soil test information included with the Contract Documents or otherwise made available to the Contractor was obtained by the Owner for use by the Architects in the design of the Project or Work. The Owner does not hold out such information to the Contractor as a completely accurate indication of subsurface conditions, and no claim for extra cost or extension of time resulting from a reliance by the Contractor on such information shall be allowed except as provided in subparagraph 3.7.4.

§ 1.2.12 Where the Work is to fit with existing conditions or work to be performed by others, the Contractor shall fully and completely join the Work with such conditions or work, unless otherwise specified. Owner provided drawings showing existing conditions or construction are based on available documents and are not guaranteed to show actual existing conditions.

§ 1.3 Capitalization

Terms capitalized in these General Conditions include those that are (1) specifically defined, (2) the titles of numbered articles, or (3) the titles of other documents published by the American Institute of Architects.

§ 1.4 Interpretation

In the interest of brevity the Contract Documents frequently omit modifying words such as "all" and "any" and articles such as "the" and "an," but the fact that a modifier or an article is absent from one statement and appears in another is not intended to affect the interpretation of either statement.

§ 1.5 Ownership and Use of Drawings, Specifications, and Other Instruments of Service

§ 1.5.1 All Drawings, Specifications and copies thereof furnished by the Owner are and shall remain the Owner's property. They are to be used only with respect to this Project and are not to be used on any other project without the prior written consent of the Owner. With the exception of one contract set for each party to the Contract, such documents are to be returned or suitably accounted for to the Owner at the completion of the Work. Submission or distribution to meet official regulatory requirements or for other purposes in connection with the Project is not to be construed as publication in derogation of any reserved rights.

§ 1.5.2 The Contractor, Subcontractors, Sub-subcontractors, and suppliers are authorized to use and reproduce the Instruments of Service provided to them, subject to any protocols established pursuant to Sections 1.7 and 1.8, solely and exclusively for execution of the Work. All copies made under this authorization shall bear the copyright notice, if any, shown on the Instruments of Service. The Contractor, Subcontractors, Sub-subcontractors, and suppliers may not use the Instruments of Service on other projects or for additions to the Project outside the scope of the Work without the specific written consent of the Owner, Architect, and the Architect's consultants.

§ 1.6 Notice

§ 1.6.1 Except as otherwise provided in Section 1.6.2, where the Contract Documents require one party to notify or give notice to the other party, such notice shall be provided in writing to the designated representative of the party to whom the notice is addressed and shall be deemed to have been duly served if delivered in person, by mail, by courier, or by electronic transmission if a method for electronic transmission is set forth in the Agreement.

§ 1.6.2 Notice of Claims as provided in Section 15.1.3 shall be provided in writing and shall be deemed to have been duly served only if delivered to the designated representative of the party to whom the notice is addressed by certified or registered mail, or by courier providing proof of delivery.

§ 1.7 Digital Data Use and Transmission

The parties shall agree upon protocols governing the transmission and use of Instruments of Service or any other information or documentation in digital form. The parties will use AIA Document E203™–2013, Building Information Modeling and Digital Data Exhibit, to establish the protocols for the development, use, transmission, and exchange of digital data.

§ 1.8 Building Information Models Use and Reliance

Any use of, or reliance on, all or a portion of a building information model without agreement to protocols governing the use of, and reliance on, the information contained in the model and without having those protocols set forth in AIA Document E203™–2013, Building Information Modeling and Digital Data Exhibit, and the requisite AIA Document G202™–2013, Project Building Information Modeling Protocol Form, shall be at the using or relying party’s sole risk and without liability to the other party and its contractors or consultants, the authors of, or contributors to, the building information model, and each of their agents and employees.

ARTICLE 2 OWNER

§ 2.1 General

§ 2.1.1 The Owner is the person or entity identified as such in the Agreement and is referred to throughout the Contract Documents as if singular in number. The Owner shall designate in writing a representative who shall have express authority to bind the Owner with respect to all matters requiring the Owner’s approval or authorization. Except as otherwise provided in Section 4.2.1, the Architect does not have such authority. The term “Owner” means the Owner or the Owner’s authorized representative.

(Paragraph Deleted)

§ 2.2 Evidence of the Owner’s Financial Arrangements

§ 2.2.1 Not Used.

§ 2.2.2 Following commencement of the Work and upon written request by the Contractor, the Owner shall furnish to the Contractor reasonable evidence that the Owner has made financial arrangements to fulfill the Owner’s obligations under the Contract only if (1) the Owner fails to make payments to the Contractor as the Contract Documents require; (2) the Contractor identifies in writing a reasonable concern regarding the Owner’s ability to make payment when due; or (3) a change in the Work materially changes the Contract Sum. If the Owner fails to provide such evidence, as required, within fourteen days of the Contractor’s request, the Contractor may immediately stop the Work and, in that event, shall notify the Owner that the Work has stopped. However, if the request is made because a change in the Work materially changes the Contract Sum under (3) above, the Contractor may immediately stop only that portion of the Work affected by the change until reasonable evidence is provided. If the Work is stopped under this Section 2.2.2, the Contract Time shall be extended appropriately and the Contract Sum shall be increased by the amount of the Contractor’s reasonable costs of shutdown, delay and start-up, plus interest as provided in the Contract Documents.

§ 2.2.3 After the Owner furnishes evidence of financial arrangements under this Section 2.2, the Owner shall not materially vary such financial arrangements without prior notice to the Contractor.

§ 2.2.4 Where the Owner has designated information furnished under this Section 2.2 as “confidential,” the Contractor shall keep the information confidential and shall not disclose it to any other person. However, the Contractor may disclose “confidential” information, after seven (7) days’ notice to the Owner, where disclosure is required by law, including a subpoena or other form of compulsory legal process issued by a court or governmental entity, or by court or arbitrator(s) order. The Contractor may also disclose “confidential” information to its employees, consultants, sureties, Subcontractors and their employees, Sub-subcontractors, and others who need to

know the content of such information solely and exclusively for the Project and who agree to maintain the confidentiality of such information.

§ 2.3 Information and Services Required of the Owner

§ 2.3.1 Except for permits and fees that are the responsibility of the Contractor under the Contract Documents, including those required under Section 3.7.1, the Owner shall secure and pay for necessary approvals, easements, assessments and charges required for construction, use or occupancy of permanent structures or for permanent changes in existing facilities.

§ 2.3.2 The Owner shall retain an architect lawfully licensed to practice architecture, or an entity lawfully practicing architecture, in the jurisdiction where the Project is located. That person or entity is identified as the Architect in the Agreement and is referred to throughout the Contract Documents as if singular in number.

§ 2.3.3 If the employment of the Architect terminates, the Owner shall employ a successor to whom the Contractor has no reasonable objection and whose status under the Contract Documents shall be that of the Architect.

§ 2.3.4 The Owner shall furnish available surveys describing physical characteristics, legal limitations and utility locations for the site of the Project, and a legal description of the site. The Contractor shall be entitled to rely on the accuracy of information furnished by the Owner except to the extent that the Contractor's review thereof reveals, or in the exercise of reasonable diligence should have revealed, any inaccuracy or incompleteness therein. The Owner makes no warranty as to the accuracy or completeness of such information. The Contractor shall exercise proper precautions relating to the safe performance of the Work.

§ 2.3.5 Information or services required of the Owner by the Contract Documents shall be furnished by the Owner with reasonable promptness after receipt from the Contractor of a written request for such information or services.

§ 2.3.6 Unless otherwise provided in the Contract Documents, the Contractor will be furnished, free of charge, 5 copies of Drawings and Project Manuals. All additional hard copies will be furnished upon request at the cost of reproduction.

§ 2.4 Owner's Right to Stop the Work

If the Contractor fails to correct Work that is not in accordance with the requirements of the Contract Documents as required by Section 12.2 or repeatedly fails to carry out Work in accordance with the Contract Documents, the Owner may issue a written order to the Contractor to stop the Work, or any portion thereof, until the cause for such order has been eliminated; however, the right of the Owner to stop the Work shall not give rise to a duty on the part of the Owner to exercise this right for the benefit of the Contractor or any other person or entity. The Contractor shall resume the Work after such stoppage promptly upon written notice to do so from the Owner. The Contractor shall remain responsible for maintaining the progress of the Work and shall not be entitled to any increase in the Contract Sum or Contract Time. The Contractor shall be responsible for all costs incurred by the Owner attributable to such an order to stop the Work.

§ 2.5 Owner's Right to Carry Out the Work

If the Contractor defaults or neglects to carry out the Work in accordance with the Contract Documents and fails within a ten-day period after receipt of notice from the Owner to commence and continue correction of such default or neglect with diligence and promptness, the Owner may, without prejudice to other remedies the Owner may have, correct such default or neglect. Such action by the Owner and amounts charged to the Contractor are both subject to prior approval of the Architect and the Architect may, pursuant to Section 9.5.1, withhold or nullify a Certificate for Payment in whole or in part, to the extent reasonably necessary to reimburse the Owner for the reasonable cost of correcting such deficiencies, including Owner's expenses and compensation for the Architect's and Owner's Project Manager's additional services made necessary by such default, neglect, or failure. If current and future payments are not sufficient to cover such amounts, the Contractor shall pay the difference to the Owner. If the Contractor disagrees with the actions of the Owner or the Architect, or the amounts claimed as costs to the Owner, the Contractor may file a Claim pursuant to Article 15.

The rights of the Owner hereunder are in addition to any other rights set forth in the Contract Documents or available at law or in equity.

ARTICLE 3 CONTRACTOR

§ 3.1 General

§ 3.1.1 The Contractor is the person or entity identified as such in the Agreement and is referred to throughout the Contract Documents as if singular in number. The Contractor shall be lawfully licensed, if required in the jurisdiction where the Project is located. The Contractor shall designate in writing a representative who shall have express authority to bind the Contractor with respect to all matters under this Contract. The term "Contractor" means the Contractor or the Contractor's authorized representative.

§ 3.1.2 The Contractor shall perform the Work in accordance with the Contract Documents.

§ 3.1.3 The Contractor shall not be relieved of its obligations to perform the Work in accordance with the Contract Documents either by activities or duties of the Architect in the Architect's administration of the Contract, or by tests, inspections or approvals required or performed by persons or entities other than the Contractor.

§ 3.2 Review of Contract Documents and Field Conditions by Contractor

§ 3.2.1 Execution of the Contract by the Contractor is a representation that the Contractor has visited the site, become familiar with local conditions under which the Work is to be performed, and correlated personal observations with requirements of the Contract Documents. The Contractor shall not be entitled to any change in the Contract Time or Contract Sum on account of its failure, or that of any Subcontractor, to comply with the foregoing requirements.

§ 3.2.2 Because the Contract Documents are complementary, the Contractor shall, before starting each portion of the Work, carefully study and compare the various Contract Documents relative to that portion of the Work, as well as the information furnished by the Owner pursuant to Section 2.3.4, shall take field measurements of any existing conditions related to that portion of the Work, and shall observe any conditions at the site affecting it. The Contractor shall promptly report to the Architect any errors, inconsistencies or omissions discovered by or made known to the Contractor as a request for information in such form as the Architect may require. If the Contractor performs any construction activity that it knows or should know involves a recognized error, inconsistency or omission in the Contract Documents without such notice to the Architect, the Contractor shall assume appropriate responsibility for such performance and shall bear responsibility for the costs of any required correction.

§ 3.2.3 The Contractor is required to ascertain that the Contract Documents are in accordance with applicable laws, statutes, ordinances, codes, rules and regulations, or lawful orders of public authorities. The Contractor shall promptly report to the Architect any nonconformity discovered by or made known to the Contractor as a request for information in such form as the Architect may require.

§ 3.2.4 If the Contractor believes that additional cost or time is involved because of clarifications or instructions the Architect issues in response to the Contractor's notices or requests for information pursuant to Sections 3.2.2 or 3.2.3, the Contractor shall submit Claims as provided in Article 15. If the Contractor fails to perform the obligations of Sections 3.2.2 or 3.2.3, the Contractor shall pay such costs and damages to the Owner, subject to Section 15.1.7, as would have been avoided if the Contractor had performed such obligations.

§ 3.2.5 Any claim by the Contractor, in submitting their bid, they did not include all items as shown in the Contract Documents, will be given no consideration for an adjustment of any kind.

§ 3.2.6 The Contractor shall give the Architect timely notice of any additional Drawings, Specifications, or instructions required to define the Work in greater detail, or to permit the proper progress of the Work.

§ 3.2.7 The Contractor shall not proceed with any Work not clearly and consistently defined in detail in the Contract Documents, but shall request additional drawings or instructions from the Architect as provided in subparagraph 3.2.5. If the Contractor proceeds with such Work without obtaining further Drawings, Specifications or instructions, the Contractor shall correct Work incorrectly done at the Contractor's own expense.

§ 3.3 Supervision and Construction Procedures

§ 3.3.1 The Contractor shall supervise and direct the work using the Contractor's best skill and attention which shall not be less than such state of skill and attention generally rendered by the contracting profession for projects similar to the Project in scope difficulty and location.

Init.

The Contractor shall adequately staff the Project to properly and thoroughly manage, schedule and supervise all construction activities.

The Contractor shall be solely responsible for and have control over construction means, methods, techniques, sequences and procedures and for coordinating all portions of the Work under the Contractor unless the Contract Documents give other specific instructions concerning these matters. Where the contract documents refer to particular construction means, methods, techniques, sequences or procedures or indicate or imply that such are to be used in the Work, such mention is intended only to indicate that the operations of the Contractor shall be such as to produce at least the quality of work implied by the operations described, by the actual determination of whether or not the described operations may be safely and suitable employed on the Work shall be the responsibility of the Contractor, who should notify the Architect in writing of the actual means, methods, techniques, sequences or procedures which will be employed on the Work, if these differ from those mentioned in the Contract Documents.

All loss, damage, or liability, or cost of correcting defective work arising from the employment of any construction means, methods, techniques, sequences, or procedures shall be corrected at Contractor's expense, notwithstanding that such construction means, methods, techniques, sequences, or procedures are referred to, indicated or implied by the Contract Documents, unless the Contractor has given timely notice to the Owner and Architect in writing that such means, methods, techniques, sequences or procedures are not safe or suitable, and the Owner has then instructed the Contractor in writing to proceed at the Owner's risk.

§ 3.3.2 The Contractor shall be responsible to the Owner for acts and omissions of the Contractor's employees, Subcontractors and their agents and employees, and other persons or entities performing portions of the Work for, or on behalf of, the Contractor or any of its Subcontractors. This obligation shall also extend to the presence on the Site of suppliers of materials or equipment, their employees, contractors, and agents engaged in the Work.

§ 3.3.3 The Contractor shall be responsible for inspection of portions of Work already performed to determine that such portions are in proper condition to receive subsequent Work.

§ 3.4 Labor and Materials

§ 3.4.1 Unless otherwise provided in the Contract Documents, the Contractor shall provide and pay for labor, materials, equipment, tools, construction equipment and machinery, water, heat, utilities, transportation, and other facilities and services necessary for proper execution and completion of the Work, whether temporary or permanent and whether or not incorporated or to be incorporated in the Work.

§ 3.4.2 Except in the case of minor changes in the Work approved by the Architect in accordance with Section 3.12.8 or ordered by the Architect in accordance with Section 7.4, the Contractor may make substitutions only with the consent of the Owner, after evaluation by the Architect and in accordance with a Change Order or Construction Change Directive.

§ 3.4.3 The Contractor shall enforce strict discipline and good order among the Contractor's employees and other persons carrying out the Work. The Contractor shall not permit employment of unfit persons or persons not properly skilled in tasks assigned to them, and the Contractor shall ensure that all workers to be employed on the Project have successfully completed a course in construction safety and health approved by the United States Occupational Safety and Health Administration (OSHA) of at least 10 hours. The Contractor shall be responsible for maintaining all safety precautions at and around the Project site. On the Owner's request, the Contractor shall permanently remove from the Project site any employee of the Contractor or any Subcontractor who fails to comply with the requirements of the Contract Documents or whose presence or behavior is deemed by the Owner to be adverse to the success of the Project or the Owner's interests.

§ 3.5 Warranty

§ 3.5.1 The Contractor warrants to the Owner and Architect that materials and equipment furnished under the Contract will be of good quality and new unless the Contract Documents require or permit otherwise and, promptly after written notification of non-conformance, shall be repaired or replaced by the Contractor with Work conforming to such requirements.

The Contractor further warrants that the Work will conform to the requirements of the Contract Documents and will be free from defects, except for those inherent in the quality of the Work the Contract Documents require or permit. Work, materials, or equipment not conforming to these requirements may be considered defective. If required by the Architect, the Contractor shall furnish satisfactory evidence as to the kind and quality of materials and

equipment.

§ 3.5.2 All material, equipment, or other special warranties required by the Contract Documents shall be issued in the name of the Owner, or shall be transferable to the Owner, and shall commence in accordance with Section 9.8.4.

**§
3.5.3**

The Contractor shall be responsible for determining that all materials furnished for the Work meet all requirements of the Contract Documents. The Architect may require the Contractor to produce reasonable evidence that a material meets such requirements, such as certified reports of past tests by qualified testing laboratories, reports of studies by qualified experts, or other evidence which, in the opinion of the Architect, would lead to a reasonable certainty that any material used, or proposed to be used, in the Work meets the requirements of the Contract Documents. All such data shall be furnished at the Contractor's expense. This provision shall not require the Contractor to pay for periodic testing of different batches of the same material, unless such testing is specifically required by the Contract Documents to be performed at the Contractor's expense.

§3.5.4 The Contractor shall guarantee all Work for a period of one year after Date of Substantial Completion, or by the terms of any special guarantee required by the Contract Documents. The Contractor shall, upon written notice from the Owner, promptly correct defective Work or Work not in accordance with the Contract Documents.

§ 3.6 Taxes

The Owner is exempt from Rhode Island sales tax on products permanently incorporated in Work of the Project.

§ 3.7 Permits, Fees, Notices and Compliance with Laws

§ 3.7.1 Unless otherwise provided in the Contract Documents, the Contractor shall secure and pay for the building permit as well as for other permits, fees, licenses, and inspections by government agencies necessary for proper execution and completion of the Work that are customarily secured after execution of the Contract and legally required at the time bids are received or negotiations concluded.

Contact the local Building Inspector's office to determine the permit costs.

§ 3.7.2 The Contractor shall comply with and give notices required by applicable laws, statutes, ordinances, codes, rules and regulations, and lawful orders of public authorities applicable to performance of the Work. If any of the Work is required to be inspected or approved by any public authority, the Contractor shall cause such inspection or approval to be performed and shall comply with any instructions or corrections ordered by the public authority.

§ 3.7.3 If the Contractor performs Work it knows or should know to be contrary to applicable laws, statutes, ordinances, codes, rules and regulations, or lawful orders of public authorities, the Contractor shall assume appropriate responsibility for such Work and shall bear the costs attributable to correction.

§ 3.7.4

(Paragraph Deleted)

If, in the course of the Work, the Contractor encounters human remains or recognizes the existence of burial markers, archaeological sites or wetlands not indicated in the Contract Documents, the Contractor shall immediately suspend any operations that would affect them and shall notify the Owner and Architect. The Contractor shall

continue to suspend such operations until otherwise instructed by the Owner but shall continue with all other operations that do not affect those remains or features.

§ 3.8 Allowances

§ 3.8.1 The Contractor shall include in the Contract Sum all allowances stated in the Contract Documents.

(Paragraphs Deleted)

§ 3.9 Superintendent

§ 3.9.1 The Contractor shall employ, in accordance with the Contract Documents, a competent superintendent and necessary assistants who shall be in attendance at the Project site at all times during performance of the Work until the date of Substantial Completion, and for such time thereafter as the Architect may determine to be necessary for the expeditious completion of the Work. The Contractor shall remove the superintendent if requested in writing by the Owner, and shall replace him/her with a competent person reasonably acceptable to Owner.

The superintendent shall represent the Contractor, and communications given to the superintendent shall be as binding as if given to the Contractor.

§ 3.9.2 The Contractor, as soon as practicable after award of the Contract, shall notify the Owner and Architect of the name and qualifications of a proposed superintendent. Within 14 days of receipt of the information, the Architect may notify the Contractor, stating whether the Owner or the Architect (1) has reasonable objection to the proposed superintendent or (2) requires additional time for review. Failure of the Architect to provide notice within the 14-day period shall constitute notice of no reasonable objection.

§ 3.9.3 The Contractor shall not employ a proposed superintendent to whom the Owner or Architect has made reasonable and timely objection. The Contractor shall not change the superintendent without the Owner's consent, which shall not unreasonably be withheld or delayed.

§ 3.9.4 The Contractor shall coordinate and supervise the Work performed by Subcontractors to the end that the Work is carried out without conflict between trades and so that no trade, at any time, causes delay to the general progress of the Work. The Contractor and all Subcontractors shall at all times afford each trade, any separate contractor, or the Owner, every reasonable opportunity for the installation of Work and the storage of materials.

§ 3.10 Contractor's Construction and Submittal Schedules

§ 3.10.1 The Contractor, within twenty (20) calenday days after being awarded the Contract, shall submit for the Owner's and Architect's information a Contractor's construction schedule for the Work. The schedule shall contain detail appropriate for the Project, including (1) the date of commencement of the Work, interim schedule milestone dates, and the date of Substantial Completion; (2) an apportionment of the Work by construction activity; and (3) the time required for completion of each portion of the Work. The schedule shall provide for the orderly progression of the Work to completion and shall not exceed time limits current under the Contract Documents. The schedule shall be revised at appropriate intervals as required by the conditions of the Work and Projector as requested by the Architect.

The construction schedule shall be in such form and contain such information as the Architect and Owner require.

The construction schedule shall be resource loaded for the Contractor and all subcontractors, with each resource identified by name, description, unit of measure, and calendar assignment. For each class of work included in the Contractor's schedule of values, the construction schedule shall show the percentage of completion to be obtained and the total dollar value of the work to be completed as of the first of each month until Substantial Completion. All calculations shall be on the basis of work in place, but not including the value of materials delivered but not in place.

§ 3.10.2 The Contractor, promptly after being awarded the Contract and thereafter as necessary to maintain a current submittal schedule, shall submit a submittal schedule for the Architect's approval. The Architect's approval shall not

be unreasonably delayed or withheld. The submittal schedule shall (1) be coordinated with the Contractor's construction schedule, and (2) allow the Architect reasonable time to review submittals. If the Contractor fails to submit a submittal schedule, or fails to provide submittals in accordance with the approved submittal schedule, the Contractor shall not be entitled to any increase in Contract Sum or extension of Contract Time based on the time required for review of submittals.

§ 3.10.3 The Contractor shall perform the Work in general accordance with the most recent schedules submitted to the Owner and Architect.

The Contractor's compliance with the construction schedule is a material obligation of the Contract.

§ 3.10.4 The Contractor shall monitor the progress of the Work for conformance with the requirements of the construction schedule and shall promptly advise the Owner of any delays or potential delays. The construction schedule shall be updated every month (or more frequently if requested by the Owner) to reflect actual conditions (such updates are sometimes referred to in these General Conditions as "progress reports"). In the event any progress report indicates delays in achievement of any milestone date set forth in such schedule, the Contractor shall propose in written form an affirmative plan (the "Recovery Schedule") to correct the delay, including overtime and/or additional labor, if necessary, which Recovery Schedule shall indicate the date by which the progress of the Work will comply with the construction schedule, and shall be subject to the approval of the Owner and the Architect. In no event shall any progress report or Recovery Schedule constitute an adjustment in the construction schedule, Contract Time or any milestone date unless any such adjustment is agreed to by the Owner and authorized pursuant to a Change Order.

§ 3.10.5 In the event (i) that the performance of the Work, as of a milestone date, has not progressed or reached the level of completion required by the construction schedule, and (ii) the progress of the Work is not brought back into compliance with the construction schedule on the date proposed by the Recovery Schedule, or the Contractor otherwise fails to comply with the Recovery Schedule, the Owner shall have the right to order the Contractor to take corrective measures to expedite the progress of the Work, including, without limitation, (1) supplying additional manpower, equipment, and facilities, (2) working additional shifts or overtime, (3) working additional days, and (4) other similar measures (hereinafter referred to collectively as "Corrective Measures"). Such Corrective Measures shall continue until the progress of the Work complies with the stage of completion required by the Contract Documents.

§ 3.10.6 The Contractor shall not be entitled to an adjustment in the Contract Sum in connection with Corrective Measures required by the Owner under or pursuant to Section 3.10.5. The Owner may exercise the rights furnished the Owner under or pursuant to Section 3.10.5 as frequently as reasonably necessary to ensure that the Contractor's performance of the Work complies with the milestone dates set forth in the construction schedule.

§ 3.11 Documents and Samples at the Site

The Contractor shall make available, at the Project site, the Contract Documents, including Change Orders, Construction Change Directives, and other Modifications, in good order and marked currently to indicate field changes and selections made during construction, and the approved Shop Drawings, Product Data, Samples, and similar required submittals. These shall be in electronic form or paper copy, available to the Architect and Owner, and delivered to the Architect for submittal to the Owner upon completion of the Work as a record of the Work as constructed.

§ 3.12 Shop Drawings, Product Data and Samples

§ 3.12.1 Shop Drawings are drawings, diagrams, schedules, and other data specially prepared for the Work by the Contractor or a Subcontractor, Sub-subcontractor, manufacturer, supplier, or distributor to illustrate some portion of the Work.

§ 3.12.2 Product Data are illustrations, standard schedules, performance charts, instructions, brochures, diagrams, and other information furnished by the Contractor to illustrate materials or equipment for some portion of the Work.

§ 3.12.3 Samples are physical examples that illustrate materials, equipment, or workmanship, and establish standards by which the Work will be judged.

Init.

§ 3.12.4 Shop Drawings, Product Data, Samples, and similar submittals are not Contract Documents. Their purpose is to demonstrate how the Contractor proposes to conform to the information given and the design concept expressed in the Contract Documents for those portions of the Work for which the Contract Documents require submittals. Review by the Architect is subject to the limitations of Section 4.2.7. Informational submittals upon which the Architect is not expected to take responsive action may be so identified in the Contract Documents. Submittals that are not required by the Contract Documents may be returned by the Architect without action.

§ 3.12.5 The Contractor shall review for compliance with the Contract Documents, approve, and submit to the Architect, Shop Drawings, Product Data, Samples, and similar submittals required by the Contract Documents, in accordance with the submittal schedule approved by the Architect or, in the absence of an approved submittal schedule, with reasonable promptness and in such sequence as to cause no delay in the Work or in the activities of the Owner or of Separate Contractors.

§ 3.12.6 By submitting Shop Drawings, Product Data, Samples, and similar submittals, the Contractor represents to the Owner and Architect that the Contractor has (1) reviewed and approved them, (2) determined and verified materials, field measurements and field construction criteria related thereto, or will do so, and (3) checked and coordinated the information contained within such submittals with the requirements of the Work and of the Contract Documents. By approving and submitting Shop Drawings, Product Data, Samples, and similar submittals the Contractor thereby represents that the Contractor has determined and verified all dimensions, quantities, field dimensions, relations to existing work, coordination with work to be installed later, coordination with information on previously accepted Shop Drawings, Product Data, Samples, or similar submittals and verification of compliance with all the requirements of the Contract Documents. The accuracy of all such information is the responsibility of the Contractor. In reviewing Shop Drawings, Product Data, Samples, and similar submittals the Architect shall be entitled to rely upon the Contractor's representation that such information is correct and accurate.

§ 3.12.7 The Contractor shall perform no portion of the Work for which the Contract Documents require submittal and review of Shop Drawings, Product Data, Samples, or similar submittals, until the respective submittal has been approved by the Architect. The accuracy of all such information is the responsibility of the Contractor. In reviewing Shop Drawings, Product Data, Samples, and similar submittals the Architect shall be entitled to rely upon the Contractor's representation that such information is correct and accurate.

§ 3.12.8 The Work shall be in accordance with approved submittals except that the Contractor shall not be relieved of responsibility for deviations from the requirements of the Contract Documents by the Architect's approval of Shop Drawings, Product Data, Samples, or similar submittals, unless the Contractor has specifically notified the Architect of such deviation at the time of submittal and (1) the Architect has given written approval to the specific deviation as a minor change in the Work, or (2) a Change Order or Construction Change Directive has been issued authorizing the deviation. The Contractor shall not be relieved of responsibility for errors or omissions in Shop Drawings, Product Data, Samples, or similar submittals, by the Architect's approval thereof.

§ 3.12.9 The Contractor shall direct specific attention, in writing or on resubmitted Shop Drawings, Product Data, Samples, or similar submittals, to revisions other than those requested by the Architect on previous submittals. In the absence of such notice, the Architect's approval of a resubmission shall not apply to such revisions.

§ 3.12.10 The Contractor shall not be required to provide professional services that constitute the practice of architecture or engineering unless such services are specifically required by the Contract Documents for a portion of the Work or unless the Contractor needs to provide such services in order to carry out the Contractor's responsibilities for construction means, methods, techniques, sequences, and procedures. The Contractor shall not be required to provide professional services in violation of applicable law.

§ 3.12.10.1 If professional design services or certifications by a design professional related to systems, materials, or equipment are specifically required of the Contractor by the Contract Documents, the Owner and the Architect will specify all performance and design criteria that such services must satisfy. The Contractor shall be entitled to rely upon the adequacy and accuracy of the performance and design criteria provided in the Contract Documents. The Contractor shall cause such services or certifications to be provided by an appropriately licensed design professional, whose signature and seal shall appear on all drawings, calculations, specifications, certifications, Shop Drawings, and other submittals prepared by such professional. Shop Drawings, and other submittals related to the Work, designed or certified by such professional, if prepared by others, shall bear such professional's written

approval when submitted to the Architect. The Owner and the Architect shall be entitled to rely upon the adequacy and accuracy of the services, certifications, and approvals performed or provided by such design professionals. Pursuant to this Section 3.12.10, the Architect will review and approve or take other appropriate action on submittals only for the limited purpose of checking for conformance with information given and the design concept expressed in the Contract Documents.

§ 3.12.10.2 If the Contract Documents require the Contractor's design professional to certify that the Work has been performed in accordance with the design criteria, the Contractor shall furnish such certifications to the Architect at the time and in the form specified by the Architect.

§ 3.12.11 When professional certification of materials, systems or equipment is required by the Contract Documents, the Owner shall be entitled to rely upon such certifications, and neither the Owner nor the Architect shall be expected to make an independent examination with respect to the performance of such materials, systems or equipment.

§ 3.13 Use of Site

The Contractor shall confine operations at the site to areas permitted by applicable laws, statutes, ordinances, codes, rules and regulations, lawful orders of public authorities, and the Contract Documents and shall not unreasonably encumber the site with materials or equipment.

The right of possession of the premises and the improvements made thereon by the Contractor shall remain at all times with the Owner. The Contractor's right to entry and use thereof arises solely from the permission granted by the Owner under the Contract Documents. The Owner shall not be liable to the Contractor, the Subcontractors, their employees, or anyone else with respect to the conditions of the premises, except only for a condition caused directly and solely by the negligence of
(Paragraph Deleted)

the

Owner.

§ 3.14 Cutting and Patching

§ 3.14.1 The Contractor shall be responsible for cutting, fitting, or patching required to complete the Work or to make its parts fit together properly. All areas requiring cutting, fitting, or patching shall be restored to the condition existing prior to the cutting, fitting, or patching, unless otherwise required by the Contract Documents.

§ 3.14.2 The Contractor shall not damage or endanger a portion of the Work or fully or partially completed construction of the Owner or Separate Contractors by cutting, patching, or otherwise altering such construction, or by excavation. The Contractor shall not cut or otherwise alter construction by the Owner or a Separate Contractor except with written consent of the Owner and of the Separate Contractor. Consent shall not be unreasonably withheld. The Contractor shall not unreasonably withhold, from the Owner or a Separate Contractor, its consent to cutting or otherwise altering the Work.

§ 3.15 Cleaning Up

§ 3.15.1 The Contractor shall keep the premises and surrounding area free from accumulation of waste materials and rubbish caused by operations under the Contract. At completion of the Work, the Contractor shall remove waste materials, rubbish, the Contractor's tools, construction equipment, machinery, and surplus materials from and about the Project site.

§ 3.15.2 If the Contractor fails to clean up as provided in the Contract Documents, the Owner may do so and the Owner shall be entitled to reimbursement from the Contractor and may deduct all costs thereof from any payment due the Contractor.

§ 3.16 Access to Work

The Contractor shall provide the Owner, Owner's representatives, and Architect with access to the Work in preparation and progress wherever located.

§ 3.17 Royalties, Patents and Copyrights

The Contractor shall pay all royalties and license fees. The Contractor shall defend suits or claims for infringement of copyrights and patent rights and shall hold the Owner and Architect harmless from loss on account thereof, but shall not be responsible for defense or loss when a particular design, process, or product of a particular manufacturer or manufacturers is required by the Contract Documents, or where the copyright violations are contained in Drawings, Specifications, or other documents prepared by the Owner or Architect. However, if an infringement of a copyright or patent is discovered by, or made known to, the Contractor, the Contractor shall be responsible for the loss unless the information is promptly furnished to the Architect.

§ 3.18 Indemnification

§ 3.18.1 To the fullest extent permitted by law the Contractor shall indemnify and hold harmless the Owner, Architect, Architect's consultants, and agents and employees of any of them from and against claims, damages, losses and expenses, including but not limited to attorneys' fees, arising out of or resulting from performance of the Work, including claims, damage, loss or expense attributable to bodily injury, sickness, disease or death, or to injury to or destruction of tangible property, including the Work, caused in whole or in part by the negligent or wrongful acts or omissions of the Contractor, a Subcontractor, anyone directly or indirectly employed by them or anyone for whose acts they may be liable, regardless of whether or not such claim, damage, loss or expense is caused in part by a party indemnified hereunder. Such obligation shall not be construed to negate, abridge, or reduce other rights or obligations, including those of indemnity, which would otherwise exist as to a party or person described in this section.

§ 3.18.2 In claims against any person or entity indemnified under this Section 3.18 by an employee of the Contractor, a Subcontractor, anyone directly or indirectly employed by them, or anyone for whose acts they may be liable, the indemnification obligation under Section 3.18.1 shall not be limited by a limitation on amount or type of damages, compensation, or benefits payable by or for the Contractor or a Subcontractor under workers' compensation acts, disability benefit acts, or other employee benefit acts.

§ 3.18.3 The obligations of the Contractor under this paragraph 3.18 shall not extend to the liability of the Architect, the Architect's consultants, and agents or employees of any of them arising out of (1) the preparation of maps, Drawings, opinions, reports, surveys, Change Orders, designs or Specifications, or (2) directions or instructions given by the Architect, the Architect's consultants and agents or employees of any of them, provided such instructions or directions are the primary cause of the injury or damage.

§ 3.18.4 The Owner and the Architect have acknowledged that nothing in the Architect's engagement implies any undertaking by the Architect for the benefit of or which may be enforced by the Contractor, its Subcontractors, or the surety of any of them; it being understood that the Architect's obligations are to the Owner and that, in performing such obligations, the Architect may increase the burdens and expense of the Contractor, its Subcontractors or the surety of any of them. Neither the Contractor, any Subcontractor, nor the surety of any of them shall bring any civil suit or other legal action against the Architect arising out of or in connection with the Project.

ARTICLE 4 ARCHITECT

§ 4.1 General

§ 4.1.1 The Architect is the person or entity retained by the Owner pursuant to Section 2.3.2 and identified as such in the Agreement.

§ 4.1.2 Duties, responsibilities, and limitations of authority of the Architect as set forth in the Contract Documents shall not be restricted, modified, or extended without written consent of the Owner and Architect. Consent of the Owner shall not be unreasonably withheld.

§ 4.2 Administration of the Contract

§ 4.2.1 The Architect will provide administration of the Contract as described in the Contract Documents and will be an Owner's representative during construction until the date the Architect issues the final Certificate for Payment. The Architect will have authority to act on behalf of the Owner only to the extent provided in the Contract Documents.

§ 4.2.2 The Architect will visit the site at intervals appropriate to the stage of construction, or as otherwise agreed with the Owner, to become generally familiar with the progress and quality of the portion of the Work completed, and to determine in general if the Work observed is being performed in a manner indicating that the Work, when fully completed, will be in accordance with the Contract Documents. However, the Architect will not be required to make exhaustive or continuous on-site inspections to check the quality or quantity of the Work. The Architect will not have control over, charge of, or responsibility for the construction means, methods, techniques, sequences or procedures, or for the safety precautions and programs in connection with the Work, since these are solely the Contractor's rights and responsibilities under the Contract Documents.

§ 4.2.3 On the basis of the site visits, the Architect will keep the Owner informed about the progress and quality of the portion of the Work completed, and promptly report to the Owner (1) known deviations from the Contract Documents, (2) known deviations from the most recent construction schedule submitted by the Contractor, and (3) defects and deficiencies observed in the Work. The Architect will not be responsible for the Contractor's failure to perform the Work in accordance with the requirements of the Contract Documents. The Architect will not have control over or charge of, and will not be responsible for acts or omissions of, the Contractor, Subcontractors, or their agents or employees, or any other persons or entities performing portions of the Work.

§ 4.2.4 Communications

The Owner and Contractor shall include the Architect in all communications that relate to or affect the Architect's services or professional responsibilities. The Owner shall promptly notify the Architect of the substance of any direct communications between the Owner and the Contractor otherwise relating to the Project. Communications by and with the Architect's consultants shall be through the Architect. Communications by and with Subcontractors and suppliers shall be through the Contractor. Communications by and with Separate Contractors shall be through the Owner. The Contract Documents may specify other communication protocols.

§ 4.2.5 Based on the Architect's evaluations of the Contractor's Applications for Payment, the Architect will review and certify the amounts due the Contractor and will issue Certificates for Payment in such amounts.

§ 4.2.6 The Architect has authority to reject Work that does not conform to the Contract Documents. Whenever the Architect considers it necessary or advisable, the Architect will have authority to require inspection or testing of the Work in accordance with Sections 13.4.2 and 13.4.3, whether or not the Work is fabricated, installed or completed. However, neither this authority of the Architect nor a decision made in good faith either to exercise or not to exercise such authority shall give rise to a duty or responsibility of the Architect to the Contractor, Subcontractors, suppliers, their agents or employees, or other persons or entities performing portions of the Work.

§ 4.2.7 The Architect will review and approve, or take other appropriate action upon, the Contractor's submittals such as Shop Drawings, Product Data, and Samples, but only for the limited purpose of checking for conformance with information given and the design concept expressed in the Contract Documents. The Architect's action will be taken in accordance with the submittal schedule approved by the Architect or, in the absence of an approved submittal schedule, with reasonable promptness while allowing sufficient time in the Architect's professional judgment to permit adequate review. Review of such submittals is not conducted for the purpose of determining the accuracy and completeness of other details such as dimensions and quantities, or for substantiating instructions for installation or performance of equipment or systems, all of which remain the responsibility of the Contractor as required by the Contract Documents. The Architect's review of the Contractor's submittals shall not relieve the Contractor of the obligations under Sections 3.3, 3.5, and 3.12. The Architect's review shall not constitute approval of safety precautions or of any construction means, methods, techniques, sequences, or procedures. The Architect's approval of a specific item shall not indicate approval of an assembly of which the item is a component.

§ 4.2.8 The Architect will prepare Change Orders and Construction Change Directives, and may order minor changes in the Work as provided in Section 7.4. The Architect will investigate and make determinations and recommendations regarding concealed and unknown conditions as provided in Section 3.7.4.

§ 4.2.9 The Architect will conduct inspections to determine the date or dates of Substantial Completion and the date of final completion; issue Certificates of Substantial Completion pursuant to Section 9.8; receive and forward to the Owner, for the Owner's review and records, written warranties and related documents required by the Contract and assembled by the Contractor pursuant to Section 9.10; and issue a final Certificate for Payment pursuant to Section 9.10.

§ 4.2.10 Not Used

§ 4.2.11 The Architect will interpret and decide matters concerning performance under, and requirements of, the Contract Documents on written request of either the Owner or Contractor. The Architect's response to such requests will be made in writing within any time limits agreed upon or otherwise with reasonable promptness.

§ 4.2.12 Interpretations and decisions of the Architect will be consistent with the intent of, and reasonably inferable from, the Contract Documents and will be in writing or in the form of drawings.

§ 4.2.13 The Architect's decisions on matters relating to aesthetic effect will be final if consistent with the intent expressed in the Contract Documents.

§ 4.2.14 The Architect will review and respond to requests for information about the Contract Documents. The Architect's response to such requests will be made in writing within any time limits agreed upon or otherwise with reasonable promptness. If appropriate, the Architect will prepare and issue supplemental Drawings and Specifications in response to the requests for information.

ARTICLE 5 SUBCONTRACTORS

§ 5.1 Definitions

§ 5.1.1 A Subcontractor is a person or entity who has a direct contract with the Contractor to perform a portion of the Work at the site. The term "Subcontractor" is referred to throughout the Contract Documents as if singular in number and means a Subcontractor or an authorized representative of the Subcontractor. The term "Subcontractor" does not include a Separate Contractor or the subcontractors of a Separate Contractor. The Subcontractor must be licensed to do the trade they are contracted to perform unless authorized otherwise by the Architect and Owner.

§ 5.1.2 A Sub-subcontractor is a person or entity who has a direct or indirect contract with a Subcontractor to perform a portion of the Work at the site. The term "Sub-subcontractor" is referred to throughout the Contract Documents as if singular in number and means a Sub-subcontractor or an authorized representative of the Sub-subcontractor.

§ 5.2 Award of Subcontracts and Other Contracts for Portions of the Work

§ 5.2.1 Unless otherwise stated in the Contract Documents, the Contractor, as soon as practicable after award of the Contract, shall notify the Owner and Architect of the persons or entities proposed for each principal portion of the Work, including those who are to furnish materials or equipment fabricated to a special design. Within 14 days of receipt of the information, the Architect may notify the Contractor whether the Owner or the Architect (1) has reasonable objection to any such proposed person or entity or (2) requires additional time for review.

§ 5.2.2 The Contractor shall not contract with a proposed person or entity to whom the Owner or Architect has made reasonable and timely objection. The Contractor shall not be required to contract with anyone to whom the Contractor has made reasonable and legally permissible objection.

§ 5.2.3 If the Owner or Architect has reasonable objection to a person or entity proposed by the Contractor, the Contractor shall propose another to whom the Owner or Architect has no reasonable objection. No increase in the Contract Sum or Contract Time shall be allowed for such change.

§ 5.2.4 The Contractor shall not substitute a Subcontractor, person, or entity for one previously selected if the Owner or Architect makes reasonable objection to such substitution.

§ 5.3 Subcontractual Relations

By appropriate written agreement, the Contractor shall require each Subcontractor, to the extent of the Work to be performed by the Subcontractor, to be bound to the Contractor by terms of the Contract Documents, and to assume toward the Contractor all the obligations and responsibilities, including the responsibility for safety of the Subcontractor's Work that the Contractor, by these Contract Documents, assumes toward the Owner and Architect. Each subcontract agreement shall preserve and protect the rights of the Owner and Architect under the Contract Documents with respect to the Work to be performed by the Subcontractor so that subcontracting thereof will not

prejudice such rights, and shall allow to the Subcontractor, unless specifically provided otherwise in the subcontract agreement, the benefit of all rights, remedies, and redress against the Contractor that the Contractor, by the Contract Documents, has against the Owner. Where appropriate, the Contractor shall require each Subcontractor to enter into similar agreements with Sub-subcontractors. The Contractor shall make available to each proposed Subcontractor, prior to the execution of the subcontract agreement, copies of the Contract Documents to which the Subcontractor will be bound, and, upon written request of the Subcontractor, identify to the Subcontractor terms and conditions of the proposed subcontract agreement that may be at variance with the Contract Documents. Subcontractors will similarly make copies of applicable portions of such documents available to their respective proposed Sub-subcontractors.

§ 5.4 Contingent Assignment of Subcontracts

§ 5.4.1 Each subcontract agreement for a portion of the Work is assigned by the Contractor to the Owner, provided that

- .1 assignment is effective only after termination of the Contract by the Owner for cause pursuant to Article 14 and only for those subcontract agreements that the Owner accepts by notifying the Subcontractor and Contractor;
- .2 assignment is subject to the prior rights of the surety, if any, obligated under bond relating to the

Contract; and

(Paragraph Deleted)

.3 the Owner may further assign the subcontract to a successor contractor or other entity.

ARTICLE 6 CONSTRUCTION BY OWNER OR BY SEPARATE CONTRACTORS

§ 6.1 Owner's Right to Perform Construction and to Award Separate Contracts

§ 6.1.1 The term "Separate Contractor(s)" shall mean other contractors retained by the Owner under separate agreements. The Owner reserves the right to perform construction or operations related to the Project with the Owner's own forces, and with Separate Contractors retained under Conditions of the Contract substantially similar to those of this Contract.

§ 6.1.2 When separate contracts are awarded for different portions of the Project or other construction or operations on the site, the term "Contractor" in the Contract Documents in each case shall mean the Contractor who executes each separate Owner-Contractor Agreement.

§ 6.1.3 The Owner shall provide for coordination of the activities of the Owner's own forces and of each Separate Contractor with the Work of the Contractor, who shall cooperate with them. The Contractor shall participate with any Separate Contractors and the Owner in reviewing their construction schedules. The Contractor shall make any revisions to its construction schedule deemed necessary after a joint review and mutual agreement. The construction schedules shall then constitute the schedules to be used by the Contractor, Separate Contractors, and the Owner until subsequently revised.

§ 6.1.4 The Owner reserves the right to enter any part of the Project site at any time to inspect the Work or to perform other work with its own forces or separate contractors, or to address any emergency situation. Such access is not to be construed to mean partial occupancy by the Owner and no claim for increase in the Contract Time or Sum will be considered unless such Owner's contractors have delayed or damaged the Contractor's Work. The Contractor shall permit the Owner to place and install as much furniture, equipment and other material during the progress of the Work as is possible before completion of the various parts of the Work and agrees that such placing and installation of equipment shall not in any way evidence the completion or acceptance of the Work or any portion of it.

§ 6.2 Mutual Responsibility

§ 6.2.1 The Contractor shall afford the Owner and Separate Contractors reasonable opportunity for introduction and storage of their materials and equipment and performance of their activities, and shall connect and coordinate the Contractor's construction and operations with theirs as required by the Contract Documents.

§ 6.2.2 If part of the Contractor's Work depends for proper execution or results upon construction or operations by the Owner or a Separate Contractor, the Contractor shall, prior to proceeding with that portion of the Work, promptly notify the Architect of apparent discrepancies or defects in the construction or operations by the Owner or Separate Contractor that would render it unsuitable for proper execution and results of the Contractor's Work. Failure of the Contractor to notify the Architect of apparent discrepancies or defects prior to proceeding with the Work shall constitute an acknowledgment that the Owner's or Separate Contractor's completed or partially completed construction is fit and proper to receive the Contractor's Work. The Contractor shall not be responsible for discrepancies or defects in the construction or operations by the Owner or Separate Contractor that are not apparent.

§ 6.2.3 The Contractor shall reimburse the Owner for costs the Owner incurs that are payable to a Separate Contractor because of the Contractor's delays, improperly timed activities or defective construction.

§ 6.2.4 The Contractor shall promptly remedy damage that the Contractor wrongfully causes to completed or partially completed construction or to property of the Owner or Separate Contractor as provided in Section 10.2.5.

(Paragraph Deleted)

§ 6.3 Owner's Right to Clean Up

If a dispute arises among the Contractor, Separate Contractors, and the Owner as to the responsibility under their respective contracts for maintaining the premises and surrounding area free from waste materials and rubbish, the Owner may clean up and the Architect will allocate the cost among those responsible.

ARTICLE 7 CHANGES IN THE WORK

§ 7.1 General

§ 7.1.1 Changes in the Work may be accomplished after execution of the Contract, and without invalidating the Contract, by Change Order, Construction Change Directive or order for a minor change in the Work, subject to the limitations stated in this Article 7 and elsewhere in the Contract Documents.

§ 7.1.2 A Change Order shall be based upon agreement among the Owner, Contractor, and Architect. A Construction Change Directive requires agreement by the Owner and Architect and may or may not be agreed to by the Contractor. An order for a minor change in the Work may be issued by the Architect alone.

§ 7.1.3 Changes in the Work shall be performed under applicable provisions of the Contract Documents. The Contractor shall proceed promptly with changes in the Work, unless otherwise provided in the Change Order, Construction Change Directive, or order for a minor change in the Work.

§ 7.2 Change Orders

§ 7.2.1 A Change Order is a written instrument prepared by the Architect and signed by the Owner, Contractor, and Architect stating their agreement upon all of the following:

- .1 The change in the Work;
- .2 The amount of the adjustment, if any, in the Contract Sum; and
- .3 The extent of the adjustment, if any, in the Contract Time.

§ 7.2.2 Upon request of the Owner or the Architect, the Contractor shall without cost to the Owner submit to the Architect, in such form as the Architect may require, an accurate written estimate of the cost of any proposed extra Work or change. The estimate shall indicate the quantity and unit cost of each item of material, and the number of hours of work and hourly rate for each class of labor, as well as a description and the amounts of all other costs chargeable under the terms of this Article. Unit labor costs for the

installation of each item of material shall be shown if required by the Architect. The Contractor shall promptly revise and resubmit each estimate if the Architect determines that it is not in compliance with the requirements of this Article, or that it contains errors of fact or mathematical errors. If required by the Architect, in order to establish the exact cost of new Work added or of previously required Work omitted, the Contractor shall obtain and furnish to the Architect bona fide proposals from recognized suppliers for furnishing any material included in such Work. Such estimates shall be furnished promptly so as to occasion no delay in the Work, and shall be furnished at the Contractor's expense. The Contractor shall state in the estimate any extension of time required for the completion of the Work if the change or extra work is ordered.

§ 7.3 Construction Change Directives

§ 7.3.1 A Construction Change Directive is a written order prepared by the Architect and signed by the Owner and Architect, directing a change in the Work prior to agreement on adjustment, if any, in the Contract Sum or Contract Time, or both. The Owner may by Construction Change Directive, without invalidating the Contract, order changes in the Work within the general scope of the Contract consisting of additions, deletions, or other revisions, the Contract Sum and Contract Time being adjusted accordingly.

§ 7.3.2 A Construction Change Directive shall be used in the absence of total agreement on the terms of a Change Order.

§ 7.3.3 If the Construction Change Directive provides for an adjustment to the Contract Sum, and if the Contract Documents include a unit price for the work that is the subject of such directive, such unit price shall be the basis of the adjustment to the Contract Sum, unless the Owner, in its sole discretion, chooses another method. If, however, the Contract Documents do not include a unit price for such work, the adjustment shall be based on one of the following methods, as selected by the Owner:

- .1 Mutual acceptance of a lump sum properly itemized and supported by sufficient substantiating data to permit evaluation;
- .2 Unit prices subsequently agreed upon;
- .3 Cost to be determined in a manner agreed upon by the parties and a mutually acceptable fixed or percentage fee; or
- .4 As provided in Section 7.3.4.

§ 7.3.4 If the proposed method of adjustment in the Contract Sum is based on unit prices that are stated in the Contract Documents, such unit prices shall be the basis of any adjustment to the Contract Sum, unless the Owner has chosen another method pursuant to subparagraph 7.3.3. If the proposed method of adjustment is not based on such unit prices and the Contractor objects to the proposed method of adjustment, the Contractor must notify the Architect of such objection in writing within five (5) calendar days from Contractor's receipt of the Construction Change Directive. Failure to so object will irrevocably waive any such objections and claims on account of such method of adjustment, and the Construction Change Directive shall be deemed and shall constitute a Change Order. If the Contractor does so object, the adjustment to the Contract Sum shall be determined by the Architect on the basis of reasonable expenditures and savings of those performing the Work attributable to the change, including, in case of an increase in the Contract Sum, an allowance for overhead and profit in accordance with the Clauses 7.3.11.1 through 7.3.11.6 below.

In such case, and also under Section 7.3.3.3, the Contractor shall keep and present, in such form as the Architect may prescribe, an itemized accounting together with appropriate supporting data. Unless otherwise provided in the Contract Documents, costs for the purposes of this Section 7.3.4 shall be limited to the following:

- .1 Costs of labor, including applicable payroll taxes, fringe benefits required by agreement or custom, workers' compensation insurance, and other employee costs approved by the Architect;
- .2 Costs of materials, supplies, and equipment, including cost of transportation, whether incorporated or consumed;
- .3 Rental costs of machinery and equipment, exclusive of hand tools, whether rented from the Contractor or others;
- .4 Costs of premiums for all bonds, insurance and permit fees directly related to the change; and
- .5 Costs of supervision and field office personnel directly attributable to the change.

§ 7.3.5 If the Contractor disagrees with the adjustment in the Contract Time, the Contractor may make a Claim in accordance with applicable provisions of Article 15.

Init.

§ 7.3.6 Upon receipt of a Construction Change Directive, the Contractor shall promptly proceed with the change in the Work involved and advise the Architect of the Contractor's agreement or disagreement with the method, if any, provided in the Construction Change Directive for determining the proposed adjustment in the Contract Sum or Contract Time.

§ 7.3.7 A Construction Change Directive signed by the Contractor indicates the Contractor's agreement therewith, including adjustment in Contract Sum and Contract Time or the method for determining them. Such agreement shall be effective immediately and shall be deemed a Change Order.

§ 7.3.8 The amount of credit to be allowed by the Contractor to the Owner for a deletion or change that results in a net decrease in the Contract Sum shall be actual net cost as confirmed by the Architect. When both additions and credits covering related Work or substitutions are involved in a change, the allowance for overhead and profit shall be figured on the basis of net increase, if any, with respect to all changes for any given trade.

§ 7.3.9 Pending final determination of the total cost of a Construction Change Directive to the Owner amounts for such changes in the Work shall not be included in Applications for Payment. Such amounts shall only be included in an Application for Payment after the adjustment for the Construction Change Directive has been included in a Change Order signed by the Owner and the Contractor. The Architect will make an interim determination for purposes of monthly certification for payment for those costs and certify for payment the amount that the Architect determines, in the Architect's professional judgment, to be reasonably justified. The Architect's interim determination of cost shall adjust the Contract Sum on the same basis as a Change Order, subject to the right of either party to disagree and assert a Claim in accordance with Article 15.

§ 7.3.10 When the Owner and Contractor agree with a determination made by the Architect concerning the adjustments in the Contract Sum and Contract Time, or otherwise reach agreement upon the adjustments, such agreement shall be effective immediately and the Architect will prepare a Change Order. Change Orders may be issued for all or any part of a Construction Change Directive.

§ 7.3.11 The allowance for the combined overhead and profit is to be as listed below.

- .1 For the Contractor, for Work performed by the Contractor's own forces, 10 percent of the cost.
- .2 For the Contractor, for Work performed by the Contractor's Subcontractor, 5 percent of the amount due the Subcontractor.
- .3 For each Subcontractor involved, for Work performed by that Subcontractor's own forces, 10 percent of the cost.
- .4 Cost to which overhead and profit is to be applied shall be determined in accordance with Subparagraph 7.3.4.
- .5 Overhead and profit is to include the Contractor's project management and supervisory costs, all administrative expenses and personnel, change estimate preparation, mobilization, setup & break-down, meetings, all safety related costs, cleanup costs and storage costs pertaining to the changes in the work.
- .6 The fee increase to any permit required by the additional work is allowed to be added to the Change Order costs. However, the Contractor is required to submit proof that the additional fee was paid to the presiding authority.
- .7 In order to facilitate checking of quotations for extras or credits, all proposals, except those so minor that their propriety can be seen by inspection, shall be accompanied by a complete itemization of costs including labor, materials and Subcontracts. Labor and materials shall be itemized in the manner prescribed above. Where major cost items are Subcontracts, they shall be itemized also. In no case will a change involving over \$500.00 be approved without such itemization.

§ 7.4 Minor Changes in the Work

The Architect may order minor changes in the Work that are consistent with the intent of the Contract Documents and do not involve an adjustment in the Contract Sum or an extension of the Contract Time. The Architect's order for minor changes shall be in writing. If the Contractor believes that the proposed minor change in the Work will affect the Contract Sum or Contract Time, the Contractor shall notify the Architect and shall not proceed to implement the change in the Work. If the Contractor performs the Work set forth in the Architect's order for a minor change without prior notice to the Architect that such change will affect the Contract Sum or Contract Time, the Contractor waives any adjustment to the Contract Sum or extension of the Contract Time.

ARTICLE 8 TIME

§ 8.1 Definitions

§ 8.1.1 Unless otherwise provided, Contract Time is the period of time, including authorized adjustments, allotted in the Contract Documents for Substantial Completion of the Work.

§ 8.1.2 The date of commencement of the Work is the date established in the Agreement.

§ 8.1.3 The date of Substantial Completion is the date certified by the Architect in accordance with Section 9.8.

§ 8.1.4 The term "day" as used in the Contract Documents shall mean calendar day unless otherwise specifically defined.

§ 8.2 Progress and Completion

§ 8.2.1 Time limits stated in the Contract Documents are of the essence of the Contract. By executing the Agreement, the Contractor confirms that the Contract Time is a reasonable period for performing the Work.

§ 8.2.2 The Contractor shall not knowingly, except by agreement or instruction of the Owner in writing, commence the Work prior to the effective date of insurance required to be furnished by the Contractor and Owner.

§ 8.2.3 The Contractor shall proceed expeditiously with adequate forces and shall achieve Substantial Completion within the Contract Time.

§ 8.2.4 Unless specifically required by law, no payment under this Contract shall be due until the construction schedule, required by Section 3.10, and conforming to the requirements of the General Requirements has been accepted by the Architect.

§ 8.2.5 If the Architect in reviewing any Application for Payment determines that the amount of completed Work in place as certified by the Architect is less than 90% of the Work in place required by the Contractor's construction schedule or schedule of values provided for in Section 9.2, or that there have been delays to critical paths and the Contract completion date will not be met, or that, in the Owner's sole discretion, there is reasonable concern that the Work will not be Substantially Complete by the date required in the Contract Documents, the Contractor shall be required to submit a recovery schedule with a written description of the steps the Contractor intends to take to put the Project back on schedule. At the Owner's option, the Contractor shall take some or all of the following actions at no additional cost to the Owner:

- .1 Increase the number of workers on the site, in such quantities and trades as will substantially eliminate the backlog of work;
- .2 Increase the number of working hours per shift, shifts per day, working days per week, amount of construction equipment, or any combination of the foregoing, sufficiently to substantially eliminate backlog of work; or
- .3 Reschedule activities so that the completion dates initially scheduled will be met.

§ 8.2.6 If the Architect has determined that the Contractor should be permitted to extend the time for completion as provided in paragraph 8.3, the calendar dates in the Progress Schedule shall be adjusted accordingly to retain their same relationship to the adjusted date of Substantial Completion, and the dollar value of Work to be completed as of the first of each month shall be adjusted prorata.

§ 8.2.7 If the Contractor fails to submit any Application for Payment in any month, the Architect shall, for the purpose of this evaluation of progress, certify separately to the actual value of the Work in place completed as of the first of the month to the best of the Architect's knowledge.

§ 8.2.8 Nothing herein shall limit the Owner's right to liquidated or other damages for delays by the Contractor or to any other remedy which the Owner may possess under other provisions of the Contract Documents or by law.

§ 8.3 Delays and Extensions of Time

§ 8.3.1 If the Contractor is delayed at any time in the commencement or progress of the Work by (1) an act or neglect of the Owner or Architect, of an employee of either, or of a Separate Contractor; (2) by changes ordered in the Work; (3) by labor disputes, fire, unusual delay in deliveries, unavoidable casualties, adverse weather conditions

AIA Document A201® – 2017. Copyright © 1911, 1915, 1918, 1925, 1937, 1951, 1958, 1961, 1963, 1966, 1970, 1976, 1987, 1997, 2007 and 2017 by The American Institute of Architects. All rights reserved. The "American Institute of Architects," "AIA," the AIA Logo, "A201," and "AIA Contract Documents" are registered trademarks and may not be used without permission. This document was produced by AIA software at 11:56:43 ET on 10/07/2022 under Order No.2114305231 which expires on 04/10/2023, is not for resale, is licensed for one-time use only, and may only be used in accordance with the AIA Contract Documents® Terms of Service. To report copyright violations, e-mail copyright@aia.org.

User Notes:

documented in accordance with Section 15.1.6.2, or other causes beyond the Contractor's control; (4) by delay authorized by the Owner or (5) by other causes that the Contractor asserts, and the Architect determines, justify delay, then the Contract Time shall be extended for such reasonable time as the Architect may determine, and this shall be the Contractor's sole remedy for such delay. Under no circumstances will the Contractor be entitled to an increase in the Contract Sum, or to any other damages, on account of or in connection with any delay, regardless of the cause of such delay, and Contractor agrees not to make any claim for such damages, including, but not limited, claims for damages on account of having to perform out-of-sequence work, claims for damages on account of loss of production, and claims for damages on account of hindrances or interference with the work.

§ 8.3.2 Claims relating to time shall be made in accordance with applicable provisions of Article 15.

§ 8.3.3 No extension of time shall be granted because of seasonal or abnormal variations in temperature, humidity or precipitation, which conditions shall be wholly at the risk of the Contractor, whether occurring within the time originally scheduled for completion or within the period of any extension granted. There shall be no increase in the Contract Sum on account of any additional costs of operations or conditions resulting therefrom.

§ 8.3.4 The Contractor hereby agrees that the Contractor shall have no claim for damages of any kind against the Owner or the Architect on account of any delay in the commencement of the Work and/or any hindrance, delay or suspension of any portion of the Work, whether such delay is caused by the Owner, the Architect, or otherwise. The Contractor acknowledges that the Contractor's sole remedy for any such delay and/or suspension will be an extension of time as provided in this Article.

§ 8.4 Liquidated Damages

§ 8.4.1 It is expressly understood and agreed, by and between the Contractor and Owner, that the time for the completion of the Work described herein is a reasonable time for the completion of same, taking into consideration the average climatic range and usual industrial and/or residential conditions prevailing in this locality. If the said Contractor shall neglect, fail or refuse to complete the Work within the times herein specified, or any proper extension thereof granted by the Owner, then the Contractor does hereby agree, as a part consideration for the awarding of this Contract, to pay to the Owner the amount stipulated in these Contract Documents, not as a penalty but as liquidated damages for such breach of contract, for each and every calendar day that the Contractor shall be in default after the time stipulated for completing the Work. The said amount is fixed and agreed upon by and between the Contractor and the Owner because of the impracticability and difficulty of fixing and ascertaining the actual damages the Owner would in such event sustain, and said amount is agreed to be the amount of damages which the Owner would sustain and said amount shall be deducted by the Owner from periodic payments.

ARTICLE 9 PAYMENTS AND COMPLETION

§ 9.1 Contract Sum

§ 9.1.1 The Contract Sum is stated in the Agreement and, including authorized adjustments, is the maximum amount payable by the Owner to the Contractor for performance of the Work under the Contract Documents.

§ 9.1.2 If unit prices are stated in the Contract Documents or subsequently agreed upon, and if quantities originally contemplated are materially changed in a proposed Change Order or Construction Change Directive so that, in the opinion of the Architect, application of such unit prices to quantities of Work proposed will cause substantial inequity to the Owner, the applicable unit prices shall be equitably adjusted.

§ 9.2 Schedule of Values

Where the Contract is based on a stipulated sum or Guaranteed Maximum Price, the Contractor shall submit a schedule of values to the Architect before the first Application for Payment, allocating the entire Contract Sum to the various portions of the Work. The schedule of values shall be prepared in the form, and supported by the data to substantiate its accuracy, required by the Architect. This schedule, unless objected to by the Architect, shall be used as a basis for reviewing the Contractor's Applications for Payment. Any changes to the schedule of values shall be submitted to the Architect and supported by such data to substantiate its accuracy as the Architect may require, and unless objected to by the Architect, shall be used as a basis for reviewing the Contractor's subsequent Applications for Payment, and shall be revised if later found by the Architect to be inaccurate. In addition, the Contractor shall submit to the Architect, at least 14 days before the first Application for Payment, a Cash Flow Schedule that shows the percentage completion to be obtained and the total dollar value of Work to be completed as of the first of each

month until Substantial Completion. All calculations in the Cash Flow Schedule shall be on the basis of Work in place and shall exclude the value of materials delivered but not in place.

§ 9.2.1 The Cash Flow Schedule shall be based on an orderly progression of the Work allowing adequate time for each operation (including adequate time for submission and review of submittals) and leading to a reasonable certainty of Substantial Completion by the date established in the Agreement. The Cash Flow Schedule will be reviewed by the Architect for compliance with the requirements of the Contract Documents.

Unless specifically required by law, no payment under this Contract shall be due until the Cash Flow Schedule has been reviewed and approved by the Architect. The Architect's review of the Cash Flow Schedule shall not impose any duty on the Architect or the Owner with respect to the timing, planning, scheduling or execution of the Work. In particular if the Contractor proposes a Cash Flow Schedule indicating a date of Substantial Completion which is earlier than the Contract Time the Contractor shall not be entitled to additional payment or compensation of any kind if for any reason the full Contract Time is required to achieve Substantial Completion of the Work.

§ 9.3 Applications for Payment

§ 9.3.1 At least ten days before the date established for each progress payment, the Contractor shall submit to the Architect an itemized Application for Payment prepared in accordance with the schedule of values, if required under Section 9.2, for completed portions of the Work. The application shall be notarized, if required, and supported by all data substantiating the Contractor's right to payment that the Owner or Architect require, such as copies of requisitions, and releases and waivers of liens from Subcontractors and suppliers, and shall reflect retainage if provided for in the Contract Documents. The form of Application for Payment shall be a notarized AIA Document G702, Application and Certification for Payment, supported by AIA Document G703, Continuation Sheet.

§ 9.3.1.1 Each Application for Payment or periodic estimate requesting payment shall be accompanied at the owner's option by (1) a waiver of liens from each Subcontractor or (ii) a certificate from each Subcontractor stating that the Subcontractor has been paid all amounts due the Subcontractor on the basis of the previous periodic payment to the Contractor, or else stating the amount not so paid and the reason for the discrepancy. In the event of any such discrepancy, the Contractor shall furnish the Contractor's own written explanation to the Owner through the Architect. Such waiver or certificate shall be in a form acceptable to the Owner.

§ 9.3.1.2 Applications for Payment shall not include requests for payment for portions of the Work for which the Contractor does not intend to pay a Subcontractor or supplier, unless such Work has been performed by others whom the Contractor intends to pay.

§ 9.3.2 Unless otherwise provided in the Contract Documents, payments shall be made on account of materials and equipment delivered and suitably stored at the site for subsequent incorporation in the Work. If approved in advance by the Owner, payment may similarly be made for materials and equipment suitably stored off the site at a location agreed upon in writing. Payment for materials and equipment stored on or off the site shall be conditioned upon compliance by the Contractor with procedures satisfactory to the Owner to establish the Owner's title to such materials and equipment or otherwise protect the Owner's interest, and shall include the costs of applicable insurance, storage, and transportation to the site, for such materials and equipment stored off the site. The Owner may deduct the amount of such costs from payments due the Contractor.

§ 9.3.3 The Contractor warrants that title to all Work covered by an Application for Payment will pass to the Owner no later than the time of payment. The Contractor further warrants that upon submittal of an Application for Payment all Work for which Certificates for Payment have been previously issued and payments received from the Owner shall, to the best of the Contractor's knowledge, information, and belief, be free and clear of liens, claims, security interests, or encumbrances, in favor of the Contractor, Subcontractors, suppliers, or other persons or entities that provided labor, materials, and equipment relating to the Work.

§ 9.4 Certificates for Payment

§ 9.4.1 Subject to the Contractor's compliance with Section 9.3 and the provisions of Section 9.6, the Architect will, within seven days after receipt of the Contractor's Application for Payment, either (1) issue to the Owner a Certificate for Payment in the full amount of the Application for Payment, with a copy to the Contractor; or (2) issue to the Owner a Certificate for Payment for such amount as the Architect determines is properly due, and notify the Contractor and Owner of the Architect's reasons for withholding certification in part as provided in Section 9.5.1; or

(3) withhold certification of the entire Application for Payment, and notify the Contractor and Owner of the Architect's reason for withholding certification in whole as provided in Section 9.5.1.

§ 9.4.2 The issuance of a Certificate for Payment will constitute a representation by the Architect to the Owner, based on the Architect's evaluation of the Work and the data in the Application for Payment, that, to the best of the Architect's knowledge, information, and belief, the Work has progressed to the point indicated, the quality of the Work is in accordance with the Contract Documents, and that the Contractor is entitled to payment in the amount certified. The foregoing representations are subject to an evaluation of the Work for conformance with the Contract Documents upon Substantial Completion, to results of subsequent tests and inspections, to correction of minor deviations from the Contract Documents prior to completion, and to specific qualifications expressed by the Architect. However, the issuance of a Certificate for Payment will not be a representation that the Architect has (1) made exhaustive or continuous on-site inspections to check the quality or quantity of the Work; (2) reviewed construction means, methods, techniques, sequences, or procedures; (3) reviewed copies of requisitions received from Subcontractors and suppliers and other data requested by the Owner to substantiate the Contractor's right to payment; or (4) made examination to ascertain how or for what purpose the Contractor has used money previously paid on account of the Contract Sum.

§ 9.5 Decisions to Withhold Certification

§ 9.5.1 The Architect may withhold a Certificate for Payment in whole or in part, to the extent reasonably necessary to protect the Owner, if in the Architect's opinion the representations to the Owner required by Section 9.4.2 cannot be made. If the Architect is unable to certify payment in the amount of the Application, the Architect will notify the Contractor and Owner as provided in Section 9.4.1. If the Contractor and Architect cannot agree on a revised amount, the Architect will promptly issue a Certificate for Payment for the amount for which the Architect is able to make such representations to the Owner. The Architect may also withhold a Certificate for Payment or, because of subsequently discovered evidence, may nullify the whole or a part of a Certificate for Payment previously issued, to such extent as may be necessary in the Architect's opinion to protect the Owner from loss for which the Contractor is responsible, including loss resulting from acts and omissions described in Section 3.3.2, because of

- .1 defective Work not remedied;
- .2 third party claims filed or reasonable evidence indicating probable filing of such claims, unless security acceptable to the Owner is provided by the Contractor;
- .3 failure of the Contractor to make payments properly to Subcontractors or suppliers for labor, materials or equipment;
- .4 reasonable evidence that the Work cannot be completed for the unpaid balance of the Contract Sum;
- .5 damage to the Owner or a Separate Contractor;
- .6 reasonable evidence that the Work will not be completed within the Contract Time, and that the retainage currently held by the Owner would not be adequate to cover actual or liquidated damages for the anticipated delay; or
- .7 repeated failure to carry out the Work in accordance with the Contract Documents.
- .8 failure of the Contractor or mechanical or electrical trade subcontractors to comply with requirements of the General Requirements for maintaining record drawings. The Contractor shall check record drawings each month. Written confirmation that the record drawings are current will be required by the Architect before approval of the Contractor's monthly payment requisition;
- .9 failure of the Contractor to provide required warranties under Section 9.3, claims for direct payment, or reasonable evidence indicating probable filing of such claims;
- .10 costs incurred by the Owner under Section 10.2.5;
- .11 failure of the Contractor to submit prerequisite documentation required by the General Requirements; or
- .12 liquidated damages due the Owner pursuant to Section 8.4.

§ 9.5.2 When either party disputes the Architect's decision regarding a Certificate for Payment under Section 9.5.1, in whole or in part, that party may submit a Claim in accordance with Article 15.

§ 9.5.3 Not Used

§ 9.5.4 If the Architect withholds certification for payment under Section 9.5.1.3, the Owner may, at its sole option, issue joint checks to the Contractor and to any Subcontractor or supplier to whom the Contractor failed to make payment for Work properly performed or material or equipment suitably delivered. If the Owner makes payments by

joint check, the Owner shall notify the Architect and the Contractor shall reflect such payment on its next Application for Payment.

§ 9.6 Progress Payments

§ 9.6.1 After the Architect has issued a Certificate for Payment, the Owner shall make payment in the manner and within the time provided in the Contract Documents, and shall so notify the Architect. The Owner reserves the right to withhold payment to the Contractor, in whole or in part, for any or all of the reasons cited in Clauses 9.5.1.1 through 9.5.1.12.

§ 9.6.2 The Contractor shall pay each Subcontractor, no later than seven days after receipt of payment from the Owner, the amount to which the Subcontractor is entitled, reflecting percentages actually retained from payments to the Contractor on account of the Subcontractor's portion of the Work. The Contractor shall, by appropriate agreement with each Subcontractor, require each Subcontractor to make payments to Sub-subcontractors in a similar manner.

§ 9.6.3 The Architect will, on request, furnish to a Subcontractor, if practicable, information regarding percentages of completion or amounts applied for by the Contractor and action taken thereon by the Architect and Owner on account of portions of the Work done by such Subcontractor.

§ 9.6.4 The Owner has the right to request written evidence from the Contractor that the Contractor has properly paid Subcontractors and suppliers amounts paid by the Owner to the Contractor for subcontracted Work. The Owner shall have the right to contact Subcontractors and suppliers to ascertain whether they have been properly paid. Neither the Owner nor Architect shall have an obligation to pay, or to see to the payment of money to, a Subcontractor or supplier, except as may otherwise be required by law.

§ 9.6.5 Not Used

§ 9.6.6 A Certificate for Payment, a progress payment, or partial or entire use or occupancy of the Project by the Owner shall not constitute acceptance of Work not in accordance with the Contract Documents.

§ 9.6.7

Provided the Owner has fulfilled its payment obligations under the Contract Documents, the Contractor shall defend and indemnify the Owner from all loss, liability, damage or expense, including reasonable attorney's fees and litigation expenses, arising out of any lien claim or other claim for payment by any Subcontractor or supplier of any tier. Upon receipt of notice of a lien claim or other claim for payment, the Owner shall notify the Contractor. If approved by the applicable court, when required, the Contractor may substitute a surety bond for the property against which the lien or other claim for payment has been asserted.

§ 9.7 Not Used

(Paragraph Deleted)

§ 9.8 Substantial Completion

§ 9.8.1 Substantial Completion is the stage in the progress of the Work when the Work or designated portion thereof is sufficiently complete in accordance with the Contract Documents so that the Owner can occupy or utilize the Work for its intended use.

In addition, Substantial Completion for the entire Project shall be achieved only when:

- .1 the Owner has beneficial occupancy and use of the entire Project for all its intended uses;
- .2 all Project systems included in the Work are operational and acceptable to the Owner;
- .3 all governmental inspections for the Project have been successfully completed, all governmental approvals and related paperwork have been delivered to the Owner, and final and unconditional certificates of occupancy for the entire Project have been delivered to the Owner,
- .4 the only remaining Work to be performed is minor in nature and the remaining Work may reasonably be performed without having a material adverse effect on or materially interfering with the Owner's occupancy and use

Init.

of the Project and

.5 all prerequisites to Substantial Completion defined in the Contract Documents have been completed.

§ 9.8.2 When the Contractor considers that the Work, or a portion thereof which the Owner agrees to accept separately, is substantially complete, the Contractor shall prepare and submit to the Architect a comprehensive list of items to be completed or corrected prior to final payment together with the estimated value of completing or correcting such items (the "Punchlist") and (2) the permits and certificates referenced in Section 13.5. The Architect shall have the right to modify and supplement the Punchlist, including the estimated value of completion or correction.

Failure to include an item on such list does not alter the responsibility of the Contractor to complete all Work in accordance with the Contract Documents.

§ 9.8.3 Upon receipt of the Contractor's list, the Architect will make an inspection to determine whether the Work or designated portion thereof is substantially complete. If the Architect's inspection discloses any item, whether or not included on the Contractor's list, which is not sufficiently complete in accordance with the Contract Documents so that the Owner can occupy or utilize the Work or designated portion thereof for its intended use, the Contractor shall, before issuance of the Certificate of Substantial Completion, complete or correct such item upon notification by the Architect. In such case, the Contractor shall then submit a request for another inspection by the Architect to determine Substantial Completion.

§ 9.8.4 When the Work or designated portion thereof is substantially complete, the Architect will prepare a Certificate of Substantial Completion that shall establish the date of Substantial Completion; establish responsibilities of the Owner and Contractor for security, maintenance, heat, utilities, damage to the Work and insurance; and fix the time within which the Contractor shall finish all items on the list accompanying the Certificate. Warranties required by the Contract Documents shall commence on the date of Substantial Completion of the Work or designated portion thereof unless otherwise provided in the Certificate of Substantial Completion.

§ 9.8.5 The Certificate of Substantial Completion shall be submitted to the Owner and Contractor by the Architect. The certificate shall state the date of substantial completion, shall state any consequent responsibilities of the Contractor and the Owner in accordance with the Contract Documents. The Contractor shall complete and correct any incomplete and defective work within the number of calendar days stipulated in these Contract Documents.

§ 9.8.6 Services provided by the Architect to conduct more than three (3) inspections of completed Work or any inspections beyond thirty (30) calendar days after the date of substantial completion of any portion of the Work as stated in the Agreement shall be paid by the Contractor to the Owner. The Owner may deduct the cost of such services and inspections from payments due the Contractor.

§ 9.9 Partial Occupancy or Use

§ 9.9.1 The Owner may occupy or use any completed or partially completed portion of the Work at any stage. Such partial occupancy or use may commence whether or not the portion is substantially complete, provided the Owner has accepted in writing the responsibilities assigned to it and the Contractor for payments, retainage, if any, security, maintenance, heat, utilities, damage to the Work and insurance. When the Contractor considers a portion substantially complete, the Contractor shall prepare and submit a list to the Architect as provided under Section 9.8.2. The stage of the progress of the Work shall be determined by written agreement between the Owner and Contractor or, if no agreement is reached, by decision of the Architect.

§ 9.9.2 Immediately prior to such partial occupancy or use, the Owner, Contractor, and Architect shall jointly inspect the area to be occupied or portion of the Work to be used in order to determine and record the condition of the Work.

§ 9.9.3 Unless otherwise agreed upon, partial occupancy or use of a portion or portions of the Work shall not constitute acceptance of Work not complying with the requirements of the Contract Documents.

§ 9.10 Final Completion and Final Payment

§ 9.10.1 Upon receipt of the Contractor's notice that the Work is ready for final inspection and acceptance and upon receipt of a final Application for Payment, the Architect will promptly make such inspection. When the Architect finds the Work acceptable under the Contract Documents and the Contract fully performed, the Architect will

Init.

promptly issue a final Certificate for Payment stating that to the best of the Architect's knowledge, information and belief, and on the basis of the Architect's on-site visits and inspections, the Work has been completed in accordance with the Contract Documents and that the entire balance found to be due the Contractor and noted in the final Certificate is due and payable. The Architect's final Certificate for Payment will constitute a further representation that conditions listed in Section 9.10.2 as precedent to the Contractor's being entitled to final payment have been fulfilled. By Final Completion, the Contractor shall have completed its performance of all Punchlist items, completed all balancing of mechanical and other applicable systems and all seasonal system adjustments that are reasonably necessary to proper functioning of the completed Project, delivered to the Owner all operations and maintenance manuals and completed related training for such manuals, and delivered to the Owner all required warranties and guarantees.

§ 9.10.2 Neither final payment nor any remaining retained percentage shall become due until the Contractor submits to the Architect (1) an affidavit that payrolls, bills for materials and equipment, and other indebtedness connected with the Work for which the Owner or the Owner's property might be responsible or encumbered (less amounts withheld by Owner) have been paid or otherwise satisfied, (2) a certificate evidencing that insurance required by the Contract Documents to remain in force after final payment is currently in effect, (3) a written statement that the Contractor knows of no reason that the insurance will not be renewable to cover the period required by the Contract Documents, (4) consent of surety, if any, to final payment, (5) documentation of any special warranties, such as manufacturers' warranties or specific Subcontractor warranties, and (6) if required by the Owner, other data establishing payment or satisfaction of obligations, such as receipts and releases and waivers of liens, claims, security interests, or encumbrances arising out of the Contract, to the extent and in such form as may be designated by the Owner. If the Contractor fails to furnish such releases or waivers as the Owner reasonably requires to satisfy the Owner that there are no outstanding liens, the Owner may require the

Contractor, as a condition of final payment and at the Contractor's expense, to furnish a bond satisfactory to the Owner to

indemnify the Owner

(Paragraphs Deleted)

against any such liens.

(Paragraph Deleted)

§ 9.10.3 Acceptance of final payment by the Contractor, a Subcontractor, or a supplier, shall constitute a waiver of claims by that payee for payment for Work performed and of all other claims of which the payee knew or should have known at the time of final payment, except those previously made in writing and identified by that payee as unsettled at the time of final Application for Payment.

ARTICLE 10 PROTECTION OF PERSONS AND PROPERTY

§ 10.1 Safety Precautions and Programs

The Contractor shall be responsible for initiating, maintaining, and supervising all safety precautions and programs in connection with the performance of the Contract.

§ 10.2 Safety of Persons and Property

§ 10.2.1 The Contractor shall take reasonable precautions for safety of, and shall provide reasonable protection to prevent damage, injury, or loss to

- .1 employees on the Work and other persons who may be affected thereby;
- .2 the Work and materials and equipment to be incorporated therein, whether in storage on or off the site, under care, custody, or control of the Contractor, a Subcontractor, or a Sub-subcontractor;
- .3 other property at the site or adjacent thereto, such as trees, shrubs, lawns, walks, pavements, roadways, structures, and utilities not designated for removal, relocation, or replacement in the course of construction; and

4 work or property of the Owner, its tenants, or other parties at or near the Project site with the Owner's permission.

§ 10.2.2 The Contractor shall comply with, and give notices required by applicable laws, statutes, ordinances, codes, rules and regulations, and lawful orders of public authorities, bearing on safety of persons or property or their protection from damage, injury, or loss.

§ 10.2.3 The Contractor shall implement, erect, and maintain, as required by existing conditions and performance of the Contract, reasonable safeguards for safety and protection, including posting danger signs and other warnings against hazards; promulgating safety regulations; and notifying the owners and users of adjacent sites and utilities of the safeguards.

§ 10.2.4 When use or storage of explosives or other hazardous materials or equipment, or unusual methods are necessary for execution of the Work, the Contractor shall exercise utmost care and carry on such activities under supervision of properly qualified personnel.

§ 10.2.5 The Contractor shall promptly remedy damage and loss (other than damage or loss insured under property insurance required by the Contract Documents) to property referred to in Sections 10.2.1.2, 10.2.1.3 and 10.2.1.4 caused in whole or in part by the Contractor, a Subcontractor, a Sub-subcontractor, or anyone directly or indirectly employed by any of them, or by anyone for whose acts they may be liable and for which the Contractor is responsible under Sections 10.2.1.2 and 10.2.1.3. The foregoing obligations of the Contractor are in addition to the Contractor's obligations under Section 3.18. Where the damage or loss presents an immediate danger to the public, the Owner, in its sole discretion and at the Contractor's expense, may promptly remedy such damage or loss without prior notice to the Contractor.

§ 10.2.6 The Contractor shall designate a responsible member of the Contractor's organization at the site whose duty shall be the prevention of accidents. This person shall be the Contractor's superintendent unless otherwise designated by the Contractor in writing to the Owner and Architect.

§ 10.2.7 The Contractor shall not permit any part of the construction or site to be loaded so as to cause damage or create an unsafe condition.

§ 10.2.8 Injury or Damage to Person or Property

If either party suffers injury or damage to person or property because of an act or omission of the other party, or of others for whose acts such party is legally responsible, notice of the injury or damage, whether or not insured, shall be given to the other party within a reasonable time not exceeding 21 days after discovery. The notice shall provide sufficient detail to enable the other party to investigate the matter.

§

10.2.9 The Contractor shall provide and maintain in good operating condition suitable and adequate fire protection equipment and services, and shall comply with all reasonable recommendations regarding fire protection made by the representatives of the fire insurance company carrying insurance on the Work or by the local fire chief or fire marshal. The area within the site limits shall be kept orderly and clean, and all combustible rubbish shall be promptly removed from the site.

§ 10.2.10 The Contractor shall at all times protect excavations, trenches, buildings and materials from rain water, groundwater, backup or leakage of sewers, drains and other piping, and from water of any other origin and shall remove promptly any accumulation of water. The Contractor shall provide and operate all pumps, piping and other equipment necessary to this end.

§ 10.2.11 The Contractor shall remove snow and ice which might result in damage or delay.

§ 10.2.12 During the progress of the Work and at all times prior to the date of Substantial Completion or occupancy of the Work by the Owner, whichever is earlier, the Contractor shall provide temporary heat, ventilation, and enclosure, adequate to permit the Work to proceed in a timely fashion, and to prevent damage to completed Work or Work in progress, or to materials stored on the premises. The use of the permanent heating and/or ventilation systems for temporary heat and/or ventilation shall be subject to the prior written approval of the Owner and

Architect.

§ 10.2.13 The Contractor shall install weather protection and furnish adequate heat in the protected area from November 1 to March 31 as necessary.

§ 10.3 Hazardous Materials and Substances

§ 10.3.1 The Contractor is responsible for compliance with any requirements included in the Contract Documents regarding hazardous materials or substances. The Contractor shall not cause or permit any introduction onto, under, or near the Owner's property of any hazardous materials or substances as defined by any applicable law, and shall not cause or permit any release, discharge, transportation, storage, or disposal of such materials or substances onto, under, or near the Owner's property or areas near the Owner's property. If the Contractor encounters or recognizes on the site any material known or

reasonably believed to be hazardous, including but not limited to asbestos or polychlorinated biphenyl (PCB), the Contractor shall immediately stop Work in the area affected and report the condition to the Owner and Architect in writing. The Contractor and the Owner shall cooperate in implementing measures to remove or contain said material and the Contractor shall comply with all directions of the Architect in the implementation of such removal or containment.

§ 10.3.2 The Contractor shall reimburse the Owner for the cost and expense the Owner incurs (1) for remediation of hazardous materials or substances the Contractor brings to the site and negligently handles, or (2) where the Contractor fails to perform its obligations under Article 10 or for any violation of applicable law related to the Contractor's noncompliance with the provisions of this Article 10.

§ 10.3.3 The parties anticipate that certain hazardous substances and/or materials may be discovered at the site. When such conditions are set forth in the Contract Documents, the Contractor acknowledges that such conditions have been considered in establishing the Contract Time and Contract Sum. No extension of the Contract Time or increase in the Contract Sum shall be claimed or allowed with respect to any hazardous substances or materials located at the site which were disclosed in the Contract Documents. The Contractor shall strictly comply with all laws, regulations, rules, orders, ordinances and the like related to the excavation, storage, removal and disposal of any such hazardous substances or materials.

§ 10.4 Emergencies

In an emergency affecting safety of persons or property, the Contractor shall act, at the Contractor's discretion, to prevent threatened damage, injury, or loss. Additional compensation or extension of time claimed by the Contractor on account of an emergency shall be determined as provided in Article 15 and Article 7.

ARTICLE 11 INSURANCE AND BONDS

§ 11.1 CONTRACTOR'S LIABILITY INSURANCE

§ 11.1.1 The Contractor shall purchase from and maintain in a company or companies lawfully authorized to do business in the jurisdiction in which the Project is located such insurance as will protect the Contractor from claims set forth below which may arise out of or result from the Contractor's operations and completed operations under the Contract

and for which the Contractor may be legally liable, whether such operations be by the Contractor or by a Subcontractor or by anyone directly or

indirectly employed by any of them, or by anyone for whose acts any of them may be liable:

- .1 Claims under workers' compensation, disability benefit and other similar employee benefit acts that are applicable to the Work to be performed;
- .2 Claims for damages because of bodily injury, occupational sickness or disease, or death of the Contractor's employees;
- .3 Claims for damages because of bodily injury, sickness or disease, or death of any person other than the Contractor's employees;
- .4 Claims for damages insured by usual personal injury liability coverage;

Init.

- .5 Claims for damages, other than to the Work itself, because of injury to or destruction of tangible property, including loss of use resulting therefrom;
- .6 Claims for damages because of bodily injury, death of a person or property damage arising out of ownership, maintenance or use of a motor vehicle;
- .7 Claims for bodily injury or property damage arising out of completed operations; and
- .8 Claims involving contractual liability insurance applicable to the Contractor's obligations under Section 3.18.

§ 11.1.2 The insurance required by Section 11.1.1 shall include all major divisions of coverage, and shall be on a comprehensive general basis including Premises and Operations (including X-C-U), Owner's and Contractor's Protective, Products and Completed Operations, and Owned, Non-owned, and Hired Motor Vehicles. Such insurance shall be written for not less than any limits of liability required by law or those set forth in the Contract Documents, whichever is greater.

(Paragraph Deleted)

All insurance shall be written on an occurrence basis, unless the Owner approves in writing coverage on a claims-made basis. Coverages, whether written on an occurrence or claims-made basis, shall be maintained without interruption from date of commencement of the Work until date of final payment and any further period during which coverage is required to be maintained after final payment by the Contract Documents. The Owner shall be named an Additional Insured on all policies.

Coverage for such liability insurance shall be provided by a company or companies reasonably acceptable to the Owner and authorized to do business in the state the project is located. Contractor shall furnish to Owner written confirmation as to the insurance carrier's most current financial ratings prior to commencing work.

§ 11.1.3 Certificates of insurance acceptable to the Owner shall be filed with the Owner prior to commencement of the Work and thereafter upon renewal or replacement of each required policy of insurance. These certificates and the insurance policies required by this Section 11.1 shall contain a provision that coverages afforded under the policies will not be canceled or allowed to expire until at least 30 days' prior written notice has been given to the Owner. An additional certificate evidencing continuation of liability coverage, including coverage for completed operations, shall be submitted with the final Application for Payment as required by Section 9.10.2 and thereafter upon renewal or replacement of such coverage until the expiration of the time required by Section 11.1.2. Information concerning reduction of coverage on account of revised limits or claims paid under the General Aggregate, or both, shall be furnished by the Contractor with reasonable promptness.

These certificates shall set forth evidence of all coverage required by Sections 11.1.1 and 11.1.2. The Contractor shall furnish to the Owner copies of any endorsements that are subsequently issued amending limits of coverage.

§ 11.1.3.1 The Contractor shall be responsible for having acceptable insurance coverage provided by or on behalf of all Subcontractors, with such insurance to be similar to that required of the Contractor under the Agreement and these General Conditions. The Contractor shall not allow any Subcontractor to commence Work on the Project prior to the Contractor's receipt of certificates of insurance that are acceptable in form and limits to the Owner; the Owner shall have no obligation to pay the Contractor for any Work performed by a Subcontractor who has not supplied acceptable insurance certificates prior to starting its Work.

The Owner shall be named an additional insured on all such certificates.

§ 11.1.3.2 All insurance policies shall contain provisions or endorsements necessary to assure coverage of claims by one insured against another. All required insurance policies are to be endorsed to state that the Contractor's policies shall be primary to all other insurance available to the Owner and other specified additional insureds for liability arising out of or resulting from the Contractor's operations under the Contract, whether such operations be by the Contractor or by a Subcontractor or by anyone directly or indirectly employed by any of them or by anyone for whose acts any of them may be liable.

§ 11.1.4 The Contractor shall cause the commercial liability coverage required by the Contract Documents to include (1) the Owner, the Owner's Project Manager, the Architect and the Architect's consultants as additional insureds for claims caused in whole or in part by the Contractor's negligent acts or omissions during the Contractor's operations;

and (2) the Owner as an additional insured for claims caused in whole or in part by the Contractor's negligent acts or omissions during the Contractor's completed operations.

§ 11.1.5 In no case shall the limits of liability be less than the following:

.1 General Liability of at least \$1,000,000 Bodily Injury and Property Damage Liability, Combined Single Limit with a \$3,000,000 Annual Aggregate Limit. Products and Completed Operations is to be maintained for up to 3 years after the completion of the project.

(Paragraph Deleted)

.2 Automobile Liability (applicable for any contractor who has an automobile operating exposure) of at least \$1,000,000 Bodily Injury and Property Damage per accident.

.3 Workers' Compensation Insurance as required by law.

.4 Builders' Risk Property Coverage for the full insurable value (completed value). It is to include "All Risk" insurance for physical loss or damage including theft.

.5 Property Coverage for materials and supplies being transported by the contractor, as the Town's Property Contract provides coverage for personal property within 1000 feet of the premises.

.6 Umbrella Liability of at least \$2,000,000/ occurrence, \$2,000,000/aggregate.

§ 11.2 OWNER'S LIABILITY INSURANCE The Contractor shall procure and pay for an Owner's policy of Owner's protective liability insurance insuring the Owner and its officers, employees and agents against claims which may arise from operations under the Contract or relating thereto.

§ 11.3 PROPERTY INSURANCE

§ 11.3.1 The Contractor shall purchase and maintain property insurance upon the entire Work at the site to the full insurable value thereof. Coverage for such liability insurance shall be provided by a company or companies reasonably acceptable to the Owner. Contractor shall furnish to Owner written confirmation as to the insurance carrier's most current financial ratings prior to commencing work. Such insurance shall include the interests of the Owner, the

Contractor, Subcontractors and Sub-subcontractors in the work and shall insure against the perils of fire and extended coverage and shall include "all risks" insurance for physical loss or

damage including without duplication, theft, vandalism and malicious mischief. This insurance shall also cover portions of

the Work stored off the site or in transit. If this insurance is written with stipulated amounts deductible, the Owner shall not be responsible for any difference between the payments made by the insurance carrier and the claim. The policy shall contain a provision that coverages afforded under policies will not be canceled or allowed to expire until at least 30 days' written notice has been given to the Owner. The Owner shall be named insured within the policy.

§ 11.3.2 The Contractor shall pay Subcontractors their just shares of insurance proceeds received by the Contractor, and by appropriate agreements, written where legally required for validity, shall require Subcontractors to make payments to their Sub-subcontractors in similar manner.

§ 11.3.3 The Owner shall have the power to adjust and settle with its insurers any loss for which it has obtained insurance.

Upon the occurrence of an insured loss, the Owner and the Contractor shall cooperate with each other and with each other's insurer in the submission of claims and related information and the distribution of any insurance proceeds. If

Init.

after such a loss no other special agreement is made, replacement of damaged work shall be covered by an appropriate change order.

§ 11.4 PERFORMANCE BOND AND PAYMENT BOND

§ 11.4.1 Contractor shall furnish bonds covering faithful performance of the Contract and payment of obligations arising thereunder, each in the amount of 100% of the Contract Price, and each by a surety company qualified to do business under the laws of the State of Rhode Island and acceptable to the Owner. The attorney-in-fact who signs the bonds on behalf of the surety, must affix to each bond a certified and current copy of the power of attorney. The Performance and Payment Bonds shall be written in a form satisfactory to the Owner.

§ 11.4.2 Upon the request of any person or entity appearing to be a potential beneficiary of bonds covering payment of obligations arising under the Contract, the Contractor shall promptly furnish a copy of the bonds or shall authorize a copy to be furnished.

ARTICLE 12 UNCOVERING AND CORRECTION OF WORK

§ 12.1 Uncovering of Work

§ 12.1.1 If a portion of the Work is covered contrary to the Architect's request or to requirements specifically expressed in the Contract Documents, it must, if requested in writing by the Architect, be uncovered for the Architect's examination and be replaced at the Contractor's expense without change in the Contract Time.

§ 12.1.2 If a portion of the Work has been covered that the Architect has not specifically requested to examine prior to its being covered, the Architect may request to see such Work and it shall be uncovered by the Contractor. If such Work is in accordance with the Contract Documents, the Contractor shall be entitled to an equitable adjustment to the Contract Sum and Contract Time as may be appropriate. If such Work is not in accordance with the Contract Documents, the costs of uncovering the Work, and the cost of correction, shall be at the Contractor's expense.

§ 12.2 Correction of Work

§ 12.2.1 Before Substantial Completion

The Contractor shall promptly correct Work rejected by the Architect or failing to conform to the requirements of the Contract Documents, discovered before Substantial Completion and whether or not fabricated, installed or completed. Costs of correcting such rejected Work, including additional testing and inspections, the cost of uncovering and replacement, and compensation for the Architect's services and expenses made necessary thereby, shall be at the Contractor's expense. The Contractor shall bear the cost of any loss or damages to the Owner resulting from such failure or defect.

§ 12.2.2 After Substantial Completion

§ 12.2.2.1 In addition to the Contractor's obligations under Section 3.5, if, within one year after the date of Substantial Completion of the Work or designated portion thereof or after the date for commencement of warranties established under Section 9.9.1, or by terms of any applicable special warranty required by the Contract Documents, any of the Work is found to be not in accordance with the requirements of the Contract Documents, the Contractor shall correct it promptly after receipt of notice from the Owner to do so, unless the Owner has previously given the Contractor a written acceptance of such condition. The Owner shall give such notice promptly after discovery of the condition. If the Contractor fails to correct nonconforming Work within a reasonable time during that period after receipt of notice from the Owner or Architect, the Owner may correct it in accordance with Section 2.5. If the correction or repair of any of the Work is required to avoid impacts to the maintenance, operation or safety of any

portion of the Project site or the Owner's property, the Owner reserves the right to undertake the repairs prior to notifying the Contractor or without waiting for the Contractor to respond, without waiving the Owner's rights under the warranties and the Owner's right to correct work under Section 2.5.

§ 12.2.2.2 The one-year period for correction of Work shall be extended with respect to portions of Work first performed after Substantial Completion by the period of time between Substantial Completion and the actual completion of that portion of the Work.

§ 12.2.2.3 The one-year period for correction of Work shall not be extended by corrective Work performed by the Contractor pursuant to this Section 12.2.

§ 12.2.3 The Contractor shall remove from the site portions of the Work that are not in accordance with the requirements of the Contract Documents and are neither corrected by the Contractor nor accepted by the Owner.

§ 12.2.4 The Contractor shall bear the cost of correcting destroyed or damaged construction of the Owner or Separate Contractors, whether completed or partially completed, caused by the Contractor's correction or removal of Work that is not in accordance with the requirements of the Contract Documents.

§ 12.2.5 Nothing contained in this Section 12.2 shall be construed to establish a period of limitation with respect to other obligations the Contractor has under the Contract Documents. Establishment of the one-year period for correction of Work as described in Section 12.2.2 relates only to the specific obligation of the Contractor to correct the Work, and has no relationship to the time within which the obligation to comply with the Contract Documents may be sought to be enforced, nor to the time within which proceedings may be commenced to establish the Contractor's liability with respect to the Contractor's obligations other than specifically to correct the Work.

§ 12.3 Acceptance of Nonconforming Work

If the Owner prefers to accept Work that is not in accordance with the requirements of the Contract Documents, the Owner may do so instead of requiring its removal and correction, in which case the Contract Sum will be reduced as appropriate and equitable. Such adjustment shall be effected whether or not final payment has been made.

ARTICLE 13 MISCELLANEOUS PROVISIONS

§ 13.1 Governing Law

The Contract shall be governed by the laws of the State of Rhode Island. If the parties have selected arbitration as the method of binding dispute resolution, the Federal Arbitration Act shall govern Section 15.4.

§ 13.2 Successors and Assigns

§ 13.2.1 The Owner and Contractor respectively bind themselves, their partners, successors, assigns, and legal representatives to covenants, agreements, and obligations contained in the Contract Documents. Neither party to the Contract shall assign the Contract as a whole without written consent of the other. If either party attempts to make an assignment without such consent, that party shall nevertheless remain legally responsible for all obligations under the Contract.

(Paragraph Deleted)

§ 13.3 Rights and Remedies

§ 13.3.1 Duties and obligations imposed by the Contract Documents and rights and remedies available thereunder shall be in addition to and not a limitation of duties, obligations, rights, and remedies otherwise imposed or available by law.

§ 13.3.2 No action or failure to act by the Owner, Architect, or Contractor shall constitute a waiver of a right or duty afforded them under the Contract, nor shall such action or failure to act constitute approval of or acquiescence in a breach thereunder, except as may be specifically agreed upon in writing.

§ 13.4 Tests and Inspections

§ 13.4.1 Tests, inspections, and approvals of portions of the Work shall be made as required by the Contract Documents and by applicable laws, statutes, ordinances, codes, rules, and regulations or lawful orders of public authorities. Unless otherwise provided, the Contractor shall make arrangements for such tests, inspections, and approvals with an independent testing laboratory or entity acceptable to the Owner, or with the appropriate public authority, and shall bear all related costs of tests, inspections, and approvals. The Contractor shall give the Architect timely notice of when and where tests and inspections are to be made so that the Architect may be present for such procedures. The Owner shall bear costs of tests, inspections, or approvals that do not become requirements until after bids are received or negotiations concluded. The Owner shall directly arrange and pay for tests, inspections, or approvals where building codes or applicable laws or regulations so require.

§ 13.4.2 If the Architect, Owner, or public authorities having jurisdiction determine that portions of the Work require additional testing, inspection, or approval not included under Section 13.4.1, the Architect will, upon written authorization from the Owner, instruct the Contractor to make arrangements for such additional testing, inspection, or approval, by an entity acceptable to the Owner, and the Contractor shall give timely notice to the Architect of when and where tests and inspections are to be made so that the Architect may be present for such procedures. Such costs, except as provided in Section 13.4.3, shall be at the Owner's expense.

§ 13.4.3 If procedures for testing, inspection, or approval under Sections 13.4.1 and 13.4.2 reveal failure of the portions of the Work to comply with requirements established by the Contract Documents, all costs made necessary by such failure, including those of repeated procedures and compensation for the Architect's services and expenses, shall be at the Contractor's expense.

§ 13.4.4 The Contractor shall obtain and deliver promptly to the Architect any occupancy permit and any certificates of final inspection of any part of the Contractor's work and operating permits for any mechanical apparatus, such as elevators, escalators, boilers, air compressors, etc., which may be required by law to permit full use and occupancy of the premises by the Owner. Receipt of such permits or certificates by the Architect shall be a condition precedent to Substantial Completion of the Work.

§ 13.4.5 If the Architect is to observe tests, inspections, or approvals required by the Contract Documents, the Architect will do so promptly and, where practicable, at the normal place of testing.

§ 13.4.6 Tests or inspections conducted pursuant to the Contract Documents shall be made promptly to avoid unreasonable delay in the Work.

§ 13.5 Interest

Payments due and unpaid under the Contract Documents shall bear interest from the date payment is due at the rate the parties agree upon in writing or, in the absence thereof, at the legal rate prevailing from time to time at the place where the Project is located.

§ 13.6 It is expressly agreed that the obligations of the Contractor hereunder arise out of contractual duties, and that the failure of the Contractor to comply with the requirements of the Contract Documents shall constitute a breach of contract, not a tort, for the purpose of applicable statutes of limitation and repose. Any cause of action which the Owner may have on account of such failure shall be deemed to accrue only when the Owner has obtained actual knowledge of such failure, not before.

§ 13.7 LIMITATION OF LIABILITY

§ 13.7.1 The Owner shall be liable, if ever, only to the extent of its interest in the Project; and no officer, director, partner, agent or employee of the Owner shall ever be personally or individually liable with respect to this Contract or the Work. Each Subcontract shall include the foregoing limitation, which shall be effective if the Owner ever succeeds to the Contractor's rights and obligations under a Subcontract.

§ 13.8 DEFENSE OF SUITS

§ 13.8.1 The Contractor shall be responsible for, shall defend and pay all costs, attorneys' fees and liabilities both direct and indirect as a result of suits arising out of this Contract.

§ 13.8.2 Neither final acceptance nor occupation of the premises by the Owner shall relieve the Contractor of responsibility for all claims for labor, materials, and equipment arising out of this Contract.

§ 13.8.3 The Contractor shall indemnify and hold harmless the Owner and the Architect and their agents and employees from and against all claims, damages, losses, and expenses including attorneys' fees arising out of or resulting from the performance of the work.

§ 13.9 EQUAL EMPLOYMENT OPPORTUNITY REQUIREMENTS

§ 13.9.1 The Contractor shall maintain policies of employment as follows:

§ 13.9.1.1 The Contractor and the Contractor's Subcontractors shall not discriminate against any employee or applicant for employment because of race, religion, color, sex or national origin. The Contractor shall take affirmative action to insure that applicants are employed, and that employees are treated during employment without regard to their race, religion, color, sex or national origin. Such action shall include, but not be limited to, the following: employment, upgrading, demotion or transfer; recruitment or recruitment advertising; layout or termination; rates of pay or other forms of compensation; and selection for training, including apprenticeship. The Contractor agrees to post in conspicuous places, available to employees and applicants for employment, notices setting forth the policies of non-discrimination.

§ 13.9.1.2 The Contractor and the Contractor's Subcontractors shall, in all solicitations or advertisements for employees placed by them or on their behalf; state that all qualified applicants will receive consideration for employment without regard to race, religion, color, sex or national origin.

§ 13.9.1.3 The Contractor shall be a signatory to the requirements of the Rhode Island Equal Employment Office.

§ 13.10 PREVAILING WAGES SCALES ON PUBLIC WORKS PROJECTS

§ 13.10.1. In accordance with Chapter 290 of the General laws of Rhode Island, 1938, as amended, the Department of Labor determined the customary and prevailing rate of wages paid to craftspersons, teamsters, and laborers in the constructing of public works by the State, and by cities and towns, and by persons contracting therewith for such construction. Violators are subject to a fine of not more than One Hundred Dollars (\$100.00) for each offense.

§ 13.10.2 The wage rates as ascertained by the Department of Labor are uniform for the State of Rhode Island and as of the date of advertisement of Contract applying to the life of this Contract. Information concerning wage rates prevailing in the construction industry in Rhode Island may be obtained from the Division of Professional Regulation, Department of Labor and Training, 1511 Pontiac Avenue, Cranston, Rhode Island, 02920 or their website www.dlt.state.ri.us.

Under no condition shall the wages paid to be less than those designated in the general classification. This clause does not relieve the Contractor or his Subcontractors from respecting any other union regulations to which he ordinarily subscribes.

§ 13.10.3 Bulletin No. 3, State Labor Laws, issued by the Rhode Island Department of Labor, pertaining to Public Works Projects (General Laws of Rhode Island, Revision of 1956, Chapter 37-12 as amended, and Chapter 77, Public Laws of 1965), is hereby made as part of this Project. These laws include, but are not limited to:

1. weekly payment of employees;
2. provisions applicable to public works contracts;
3. payment of prevailing wage rates;
4. posting of prevailing wage rates; and
5. overtime compensation.

§ 13.11 MINORITY BUSINESS REQUIREMENTS

In accordance with RI Gen. Law § 37-14.1-1, it is the policy of the State of Rhode Island to support the fullest possible participation of firms owned and controlled by minorities (MBEs) and women (WBEs). Pursuant to §§ 37-14.1-2 and 37-14.1-6, MBEs and WBEs shall be included in all state purchasing, including, but not limited to, the procurement of goods, services, construction projects, or contracts funded in whole or in part with state funds, or funds which, in accordance with a federal grant or otherwise, the state expends or administers. MBEs and WBEs

shall be awarded a minimum of twenty percent (20%) of the dollar value of the entire procurement or project. MBE participation credit shall only be granted for firms duly certified as MBEs or WBEs by the State of Rhode Island, Department of Administration, Office of Diversity, Equity and Opportunity, MBE Compliance Office (MBECO). The current directory of firms certified as MBEs and WBEs may be accessed at <http://odeo.ri.gov/offices/mbeco/mbe-wbe.php> or by contacting Dorinda Keene at the MBECO at (401) 574-8670 or via email at

(Paragraph Deleted)

Dorinda.Keene@doa.ri.gov.

ARTICLE 14 TERMINATION OR SUSPENSION OF THE CONTRACT

§ 14.1 Termination by the Contractor

§ 14.1.1 Provided that the Contractor is not in breach of any of its obligations under the Contract, the Contractor may terminate the Contract if the Work is stopped for a period of 30 consecutive days through no act or fault of the Contractor, a Subcontractor, a Sub-subcontractor, their agents or employees, or any other persons or entities performing portions of the Work

(Paragraph Deleted)

because the Architect has not issued a Certificate for Payment and has not notified the Contractor of the reason for withholding certification as provided in Section 9.4.1, or because the Owner has not made payment on a Certificate for Payment within the time stated in the Contract Documents.

(Paragraph Deleted)

§ 14.1.2 Not Used

§ 14.1.3 If one of the above reasons exists, the Contractor may, upon seven days written notice to the Owner and Architect, terminate the Contract and recover from the Owner payment for Work properly executed and for all materials or equipment not incorporated in the Work, but delivered and suitably stored at the site. The payment for materials or equipment stored at the site shall be conditioned upon submission by

the Contractor of bills of sale or such other evidence as is satisfactory to the Owner to establish the Owner's title to such material or equipment or otherwise protect the Owner's interest.

§ 14.2 Termination by the Owner for Cause

§ 14.2.1 The Owner may terminate the Contract if the Contractor

- .1 refuses or fails to supply enough properly skilled workers or proper materials;
- .2 fails to make payment to Subcontractors or suppliers in accordance with the respective agreements between the Contractor and the Subcontractors or suppliers;
- .3 disregards applicable laws, statutes, ordinances, codes, rules and regulations, or lawful orders of a public authority;
- .4 becomes the subject of a voluntary petition in bankruptcy or any voluntary proceeding related to insolvency, receivership, liquidation or comparable proceeding or any assignment for the benefit of creditors or becomes the subject of an involuntary petition in bankruptcy or any involuntary proceeding related to insolvency, receivership, liquidation or comparable proceeding or any assignment for the benefit of creditors;
- .5 submits three successive Applications for Payment, each of which indicate that the actual Work completed is less than 90 percent of the values estimated in the construction schedule (submitted by the Contractor pursuant to Section 3.10.1) to be completed by the respective dates; or
- .6 otherwise is guilty of substantial breach of a provision of the Contract Documents.

§ 14.2.2 When any of the reasons described in Section 14.2.1 exist, and upon certification by the Architect that sufficient cause exists to justify such action, the Owner may, without prejudice to any other rights or remedies of the

Owner and after giving the Contractor and the Contractor's surety, if any, seven days' notice, terminate employment of the Contractor and may, subject to any prior rights of the surety:

- .1 Exclude the Contractor from the site and take possession of all materials, equipment, tools, and construction equipment and machinery thereon owned by the Contractor;
- .2 Accept assignment of subcontracts pursuant to Section 5.4; and
- .3 Finish the Work by whatever reasonable method the Owner may deem expedient.

§ 14.2.3 When the Owner terminates the Contract for one of the reasons stated in Section 14.2.1, the Contractor shall not be entitled to receive further payment until the Work is finished.

§ 14.2.4 If the unpaid balance of the Contract Sum exceeds costs of finishing the Work, including all costs and losses incurred by the Owner on account of the Contractor's failure to comply with the Contract Documents and compensation for the Architect's and Owner's Project Manager's services and expenses made necessary thereby, and other damages incurred by the Owner and not expressly waived, such excess shall be paid to the Contractor. If such costs and damages exceed the unpaid balance, the Contractor shall pay the difference to the Owner. The Owner shall be entitled to hold all amounts due the Contractor at the date of termination until all of the Owner's damages have been established, and to apply such amounts to such damages.

§ 14.3 Suspension by the Owner for Convenience

§ 14.3.1 The Owner may, without cause, order the Contractor in writing to suspend, delay or interrupt the Work, in whole or in part for such period of time as the Owner may determine.

§ 14.3.2 The Contract Sum and Contract Time shall be adjusted for increases in the cost and time caused by suspension, delay, or interruption under Section 14.3.1, subject to compliance with the conditions of Section 8.3. No adjustment shall be made to the extent

- .1 that performance is, was, or would have been, so suspended, delayed, or interrupted, by another cause for which the Contractor is responsible; or
- .2 that an equitable adjustment is made or denied under another provision of the Contract.

§ 14.4 Termination by the Owner for Convenience

§ 14.4.1 The Owner may, at any time, terminate the Contract for the Owner's convenience and without cause.

§ 14.4.2 Upon receipt of notice from the Owner of such termination for the Owner's convenience, the Contractor shall

- .1 cease operations as directed by the Owner in the notice;
- .2 take actions necessary, or that the Owner may direct, for the protection and preservation of the Work; and
- .3 except for Work directed to be performed prior to the effective date of termination stated in the notice, terminate all existing subcontracts and purchase orders and enter into no further subcontracts and purchase orders.

§ 14.4.3 In the event that the Contract is terminated for the Owner's convenience, the Contractor shall be reimbursed in accordance with the Contract Documents for all Work properly performed up to the termination date, and for all materials or equipment not incorporated in the Work, but delivered and suitably stored at the site.

Payment for materials or equipment stored at the site shall be conditioned upon submission by the Contractor of bills of sale or such other evidence as is satisfactory to the Owner to establish the Owner's title to such material or equipment or otherwise protect the Owner's interest. The Contractor shall not be entitled to payment for overhead and profit on the Work not executed.

ARTICLE 15 CLAIMS AND DISPUTES

§ 15.1 Claims

§ 15.1.1 Definition

The word "Claim" shall mean a written demand by the Contractor for an increase in the Contract Time or the Contract Sum. The Contractor is responsible for substantiating its Claims. The word "Claim" shall not include claims by the Owner. The Owner may withhold from the

(Paragraph Deleted)

Contractor the value of any claims against the Contractor.

§ 15.1.2 Notice of Claims

Contractor must initiate Claims within fourteen (14) calendar days after occurrence of the event giving rise to such Claim by written notice to the Architect and the Owner. Such written notice must (1) be signed by the Contractor; (2) conspicuously identify on its face that the notice serves as a notice of claim; (3) explain in sufficient detail the basis of the Claim; (4) identify the date of the event giving rise to such Claim; and (5) state the exact dollar amount of the increase in the

Contract Sum being requested, if any, and the number of days extension to the Contract Time sought, if any.

§ 15.1.3 Not Used

§ 15.1.4 Continuing Contract Performance

§ 15.1.4.1 Pending final resolution of a Claim, except as otherwise agreed in writing or as provided in Article 14, the Contractor shall proceed diligently with performance of the Contract and the Owner shall continue to make payments in accordance with the Contract Documents.

§ 15.1.4.2 The Contract Sum and Contract Time shall be adjusted in accordance with the Initial Decision Maker's decision, subject to the right of either party to proceed in accordance with this Article 15. The Architect will issue Certificates for Payment in accordance with the decision of the Initial Decision Maker.

§ 15.1.5 Claims for Additional Cost

If the Contractor wishes to make a Claim for an increase in the Contract Sum, notice as provided in Section 15.1.3 shall be given before proceeding to execute the portion of the Work that is the subject of the Claim. Prior notice is not required for Claims relating to an emergency endangering life or property arising under Section 10.4.

§ 15.1.6 Claims for Additional Time

§ 15.1.6.1 If the Contractor wishes to make a Claim for an increase in the Contract Time, notice as provided in Section 15.1.3 shall be given. The Contractor's Claim shall include an estimate of probable effect of delay on progress of the Work. In the case of a continuing delay, only one Claim is necessary.

§ 15.1.6.2 If adverse weather conditions are the basis for a Claim for additional time, such Claim shall be documented by data substantiating that weather conditions were abnormal for the period of time, could not have been reasonably anticipated, and had an adverse effect on the scheduled construction.

§ 15.1.7 Waiver of Claims for Consequential Damages

The Contractor and Owner waive Claims against each other for consequential damages arising out of or relating to this Contract. This mutual waiver includes

- .1 damages incurred by the Owner for rental expenses, for losses of use, income, profit, financing, business and reputation, and for loss of management or employee productivity or of the services of such persons; and
- .2 damages incurred by the Contractor for principal office expenses including the compensation of personnel stationed there, for losses of financing, business and reputation, and for loss of profit, except anticipated profit arising directly from the Work.

This mutual waiver is applicable, without limitation, to all consequential damages due to either party's termination in accordance with Article 14. Nothing contained in this Section 15.1.7 shall be deemed to preclude assessment of liquidated damages, when applicable, in accordance with the requirements of the Contract Documents.

§ 15.2 Initial Decision

§ 15.2.1 Claims, excluding those where the condition giving rise to the Claim is first discovered after expiration of the period for correction of the Work set forth in Section 12.2.2 or arising under Sections 10.3, 10.4, and 11.5, shall be referred to the Initial Decision Maker for initial decision. The Architect will serve as the Initial Decision Maker,

unless otherwise indicated in the Agreement. Except for those Claims excluded by this Section 15.2.1, an initial decision shall be required as a condition precedent to mediation of any Claim. If an initial decision has not been rendered within 30 days after the Claim has been referred to the Initial Decision Maker, the party asserting the Claim may demand mediation and binding dispute resolution without a decision having been rendered. Unless the Initial Decision Maker and all affected parties agree, the Initial Decision Maker will not decide disputes between the Contractor and persons or entities other than the Owner.

§ 15.2.2 The Initial Decision Maker will review Claims and within ten days of the receipt of a Claim take one or more of the following actions: (1) request additional supporting data from the claimant or a response with supporting data from the other party, (2) reject the Claim in whole or in part, (3) approve the Claim, (4) suggest a compromise, or (5) advise the parties that the Initial Decision Maker is unable to resolve the Claim if the Initial Decision Maker lacks sufficient information to evaluate the merits of the Claim or if the Initial Decision Maker concludes that, in the Initial Decision Maker's sole discretion, it would be inappropriate for the Initial Decision Maker to resolve the Claim.

§ 15.2.3 In evaluating Claims, the Initial Decision Maker may, but shall not be obligated to, consult with or seek information from either party or from persons with special knowledge or expertise who may assist the Initial Decision Maker in rendering a decision. The Initial Decision Maker may request the Owner to authorize retention of such persons at the Owner's expense.

§ 15.2.4 If the Initial Decision Maker requests a party to provide a response to a Claim or to furnish additional supporting data, such party shall respond, within ten days after receipt of the request, and shall either (1) provide a response on the requested supporting data, (2) advise the Initial Decision Maker when the response or supporting data will be furnished, or (3) advise the Initial Decision Maker that no supporting data will be furnished. Upon receipt of the response or supporting data, if any, the Initial Decision Maker will either reject or approve the Claim in whole or in part.

§ 15.2.5 The Initial Decision Maker will render an initial decision approving or rejecting the Claim, or indicating that the Initial Decision Maker is unable to resolve the Claim. This initial decision shall (1) be in writing; (2) state the reasons therefor; and (3) notify the parties and the Architect, if the Architect is not serving as the Initial Decision Maker, of any change in the Contract Sum or Contract Time or both. The initial decision shall be final and binding on the parties but subject to mediation and, if the parties fail to resolve their dispute through mediation, to binding dispute resolution.

§ 15.2.6 Either party may file for mediation of an initial decision at any time, subject to the terms of Section 15.2.6.1.

§ 15.2.6.1 Either party may, within 30 days from the date of receipt of an initial decision, demand in writing that the other party file for mediation. If such a demand is made and the party receiving the demand fails to file for mediation within 30 days after receipt thereof, then both parties waive their rights to mediate or pursue binding dispute resolution proceedings with respect to the initial decision.

§ 15.2.7 In the event of a Claim against the Contractor, the Owner may, but is not obligated to, notify the surety, if any, of the nature and amount of the Claim. If the Claim relates to a possibility of a Contractor's default, the Owner may, but is not obligated to, notify the surety and request the surety's assistance in resolving the controversy.

§ 15.2.8 If a Claim relates to or is the subject of a mechanic's lien, the party asserting such Claim may proceed in accordance with applicable law to comply with the lien notice or filing deadlines.

§ 15.3 Mediation

§ 15.3.1 Claims, disputes, or other matters in controversy arising out of or related to the Contract, except those waived as provided for in Sections 9.10.4, 9.10.5, and 15.1.7, shall be subject to mediation as a condition precedent to binding dispute resolution.

§ 15.3.2 The parties shall endeavor to resolve their Claims by mediation which, unless the parties mutually agree otherwise, shall be administered by the American Arbitration Association in accordance with its Construction Industry Mediation Procedures in effect on the date of the Agreement. A request for mediation shall be made in writing, delivered to the other party to the Contract, and filed with the person or entity administering the mediation.

The request may be made concurrently with the filing of binding dispute resolution proceedings but, in such event, mediation shall proceed in advance of binding dispute resolution proceedings, which shall be stayed pending mediation for a period of 60 days from the date of filing, unless stayed for a longer period by agreement of the parties or court order. If an arbitration is stayed pursuant to this Section 15.3.2, the parties may nonetheless proceed to the selection of the arbitrator(s) and agree upon a schedule for later proceedings.

§ 15.3.3 Either party may, within 30 days from the date that mediation has been concluded without resolution of the dispute or 60 days after mediation has been demanded without resolution of the dispute, demand in writing that the other party file for binding dispute resolution. If such a demand is made and the party receiving the demand fails to file for binding dispute resolution within 60 days after receipt thereof, then both parties waive their rights to binding dispute resolution proceedings with respect to the initial decision.

§ 15.3.4 The parties shall share the mediator's fee and any filing fees equally. The mediation shall be held in the place where the Project is located, unless another location is mutually agreed upon. Agreements reached in mediation shall be enforceable as settlement agreements in any court having jurisdiction thereof.

§ 15.4 Arbitration

§ 15.4.1 If the parties have selected arbitration as the method for binding dispute resolution in the Agreement, any Claim subject to, but not resolved by, mediation shall be subject to arbitration which, unless the parties mutually agree otherwise, shall be administered by the American Arbitration Association in accordance with its Construction Industry Arbitration Rules in effect on the date of the Agreement. The Arbitration shall be conducted in the place where the Project is located, unless another location is mutually agreed upon. A demand for arbitration shall be made in writing, delivered to the other party to the Contract, and filed with the person or entity administering the arbitration. The party filing a notice of demand for arbitration must assert in the demand all Claims then known to that party on which arbitration is permitted to be demanded.

§ 15.4.1.1 A demand for arbitration shall be made no earlier than concurrently with the filing of a request for mediation, but in no event shall it be made after the date when the institution of legal or equitable proceedings based on the Claim would be barred by the applicable statute of limitations. For statute of limitations purposes, receipt of a written demand for arbitration by the person or entity administering the arbitration shall constitute the institution of legal or equitable proceedings based on the Claim.

§ 15.4.2 The award rendered by the arbitrator or arbitrators shall be final, and judgment may be entered upon it in accordance with applicable law in any court having jurisdiction thereof.

§ 15.4.3 The foregoing agreement to arbitrate and other agreements to arbitrate with an additional person or entity duly consented to by parties to the Agreement, shall be specifically enforceable under applicable law in any court having jurisdiction thereof.

§ 15.4.4 Consolidation or Joinder

§ 15.4.4.1 Subject to the rules of the American Arbitration Association or other applicable arbitration rules, either party may consolidate an arbitration conducted under this Agreement with any other arbitration to which it is a party provided that (1) the arbitration agreement governing the other arbitration permits consolidation, (2) the arbitrations to be consolidated substantially involve common questions of law or fact, and (3) the arbitrations employ materially similar procedural rules and methods for selecting arbitrator(s).

§ 15.4.4.2 Subject to the rules of the American Arbitration Association or other applicable arbitration rules, either party may include by joinder persons or entities substantially involved in a common question of law or fact whose presence is required if complete relief is to be accorded in arbitration, provided that the party sought to be joined consents in writing to such joinder. Consent to arbitration involving an additional person or entity shall not constitute consent to arbitration of any claim, dispute or other matter in question not described in the written consent.

§ 15.4.4.3 The Owner and Contractor grant to any person or entity made a party to an arbitration conducted under this Section 15.4, whether by joinder or consolidation, the same rights of joinder and consolidation as those of the Owner and Contractor under this Agreement.

DOCUMENT 00 73 46

PREVAILING WAGE RATES

The State of Rhode Island Department of Labor, Division of Professional Regulation General Decision Modification document, current as of the bid issuance date for this Project, is an integral part of the Bid Documents for use in fulfilling prevailing wage rate requirements. A copy is included following this page.

Additional information concerning prevailing wage rates may be obtained from the Rhode Island Division of Professional Regulation, Department of Labor and Training, 1511 Pontiac Avenue, Cranston, Rhode Island, 02920.

"General Decision Number: RI20240001 04/05/2024

Superseded General Decision Number: RI20230001

State: Rhode Island

Construction Types: Building, Heavy (Heavy and Marine) and Highway

Counties: Rhode Island Statewide.

BUILDING CONSTRUCTION PROJECTS (does not include residential construction consisting of single family homes and apartments up to and including 4 stories) HEAVY, HIGHWAY AND MARINE CONSTRUCTION PROJECTS

Note: Contracts subject to the Davis-Bacon Act are generally required to pay at least the applicable minimum wage rate required under Executive Order 14026 or Executive Order 13658. Please note that these Executive Orders apply to covered contracts entered into by the federal government that are subject to the Davis-Bacon Act itself, but do not apply to contracts subject only to the Davis-Bacon Related Acts, including those set forth at 29 CFR 5.1(a)(1).

If the contract is entered	. Executive Order 14026	
into on or after January 30,	generally applies to the	
2022, or the contract is	contract.	
renewed or extended (e.g., an	. The contractor must pay	
option is exercised) on or	all covered workers at	
after January 30, 2022:	least \$17.20 per hour (or	
	the applicable wage rate	
	listed on this wage	
	determination, if it is	
	higher) for all hours	

	spent performing on the contract in 2024.
If the contract was awarded on or between January 1, 2015 and January 29, 2022, and the contract is not renewed or extended on or after January 30, 2022:	Executive Order 13658 generally applies to the contract. The contractor must pay all covered workers at least \$12.90 per hour (or the applicable wage rate listed on this wage determination, if it is higher) for all hours spent performing on that contract in 2024.

The applicable Executive Order minimum wage rate will be adjusted annually. If this contract is covered by one of the Executive Orders and a classification considered necessary for performance of work on the contract does not appear on this wage determination, the contractor must still submit a conformance request.

Additional information on contractor requirements and worker protections under the Executive Orders is available at <http://www.dol.gov/whd/govcontracts>.

Modification Number	Publication Date
0	01/05/2024
1	01/12/2024
2	02/23/2024
3	03/08/2024
4	03/22/2024
5	04/05/2024

ASBE0006-006 09/01/2023

	Rates	Fringes
HAZARDOUS MATERIAL HANDLER (Includes preparation, wetting, stripping, removal scrapping, vacuuming, bagging & disposing of all insulation materials, whether they contain asbestos or not, from mechanical systems).....	\$ 48.15	34.84

ASBE0006-008 09/01/2023

	Rates	Fringes
Asbestos Worker/Insulator Includes application of all insulating materials, protective coverings, coatings & finishes to all types of mechanical systems.	\$ 48.15	34.84

 BOIL0029-001 01/01/2021

	Rates	Fringes
BOILERMAKER.....	\$ 45.87	29.02

 BRRI0003-001 06/01/2022

	Rates	Fringes
Bricklayer, Stonemason, Pointer, Caulker & Cleaner.....	\$ 46.86	29.14

 BRRI0003-002 09/01/2022

	Rates	Fringes
Marble Setter, Terrazzo Worker & Tile Setter.....	\$ 46.54	30.34

 BRRI0003-003 09/01/2022

	Rates	Fringes
Marble, Tile & Terrazzo Finisher.....	\$ 38.78	29.61

 CARP0330-001 01/01/2024

	Rates	Fringes
CARPENTER (Includes Soft Floor Layer).....	\$ 43.63	30.25
Diver Tender.....	\$ 44.88	30.25
DIVER.....	\$ 57.03	30.25
Piledriver.....	\$ 41.53	29.35
WELDER.....	\$ 44.88	30.25

FOOTNOTES:

When not diving or tending the diver, the diver and diver tender shall receive the piledriver rate. Diver tenders shall receive \$1.00 per hour above the pile driver rate when tending the diver.

Work on free-standing stacks, concrete silos & public utility electrical power houses, which are over 35 ft. in height when constructed: \$.50 per hour additional.

Work on exterior concrete shear wall gang forms, 45 ft. or more above ground elevation or on setback: \$.50 per hour additional.

The designated piledriver, known as the "monkey": \$1.00 per hour additional.

CARP1121-002 01/02/2023

	Rates	Fringes
MILLWRIGHT.....	\$ 41.54	30.73

ELEC0099-002 06/01/2023

	Rates	Fringes
ELECTRICIAN.....	\$ 48.61	50.44%
Teledata System Installer.....	\$ 36.46	11.59%+15.31

FOOTNOTES:

Work of a hazardous nature, or where the work height is 30 ft. or more from the floor, except when working OSHA-approved lifts: 20% per hour additional.

Work in tunnels below ground level in combined sewer outfall: 20% per hour additional.

ELEV0039-001 01/01/2023

	Rates	Fringes
ELEVATOR MECHANIC.....	\$ 59.36	37.335+a+b

FOOTNOTES:

a. PAID HOLIDAYS: New Years Day; Memorial Day; Independence Day; Labor Day; Veterans' Day; Thanksgiving Day; the Friday

after Thanksgiving Day; and Christmas Day.

b. Employer contributes 8% basic hourly rate for 5 years or more of service of 6% basic hourly rate for 6 months to 5 years of service as vacation pay credit.

 ENGI0057-001 11/01/2023

	Rates	Fringes
Operating Engineer: (power plants, sewer treatment plants, pumping stations, tunnels, caissons, piers, docks, bridges, wind turbines, subterranean & other marine and heavy construction work)		
GROUP 1.....	\$ 41.95	29.75
GROUP 2.....	\$ 39.95	29.75
GROUP 3.....	\$ 35.23	29.75
GROUP 4.....	\$ 38.93	29.75
GROUP 5.....	\$ 38.93	29.75
GROUP 6.....	\$ 34.65	29.75
GROUP 7.....	\$ 28.65	29.75
GROUP 8.....	\$ 34.20	29.75
GROUP 9.....	\$ 43.17	29.45

a. BOOM LENGTHS, INCLUDING JIBS:

- 150 feet and over + \$ 2.00
- 180 feet and over + \$ 3.00
- 210 feet and over + \$ 4.00
- 240 feet and over + \$ 5.00
- 270 feet and over + \$ 7.00
- 300 feet and over + \$ 8.00
- 350 feet and over + \$ 9.00
- 400 feet and over + \$10.00

a. PAID HOLIDAYS:

New Year's Day, President's Day, Memorial Day, July Fourth, Victory Day, Labor Day, Columbus Day, Veterans Day, Thanksgiving Day, Christmas Day. a: Any employee who works 3 days in the week in which a holiday falls shall be paid for the holiday.

a. FOOTNOTES:

Hazmat work: \$2.00 per hour additional.
 Tunnel/Shaft work: \$5.00 per hour additional.

POWER EQUIPMENT OPERATORS CLASSIFICATIONS

GROUP 1: Cranes, lighters, boom trucks and derricks

GROUP 2: Digging machine, Ross Carrier, locomotive, hoist, elevator, bidwell-type machine, shot & water blasting machine, paver, spreader, graders, front end loader (3 yds. and over), vibratory hammer & vacuum truck, roadheaders, forklifts, economobile type equipment, tunnel boring machines, concrete pump and on site concrete plants.

GROUP 3: Oilers on cranes.

GROUP 4: Oiler on crawler backhoe.

GROUP 5: Bulldozer, bobcats, skid steer loader, tractor, scraper, combination loader backhoe, roller, front end loader (less than 3 yds.), street and mobile-powered sweeper (3-yd. capacity), 8-ft. sweeper minimum 65 HP).

GROUP 6: Well-point installation crew.

GROUP 7: Utility Engineers and Signal Persons

GROUP 8: Heater, concrete mixer, stone crusher, welding machine, generator and light plant, gas and electric driven pump and air compressor.

GROUP 9: Boat & tug operator.

 ENGI0057-002 11/01/2023

	Rates	Fringes
Power Equipment Operator (highway construction projects; water and sewerline projects which are incidental to highway construction projects; and bridge projects that do not span water)		
GROUP 1.....	\$ 41.95	29.75
GROUP 2.....	\$ 39.95	29.75
GROUP 3.....	\$ 35.23	29.75
GROUP 4.....	\$ 38.93	29.75
GROUP 5.....	\$ 38.93	29.75
GROUP 6.....	\$ 34.65	29.75
GROUP 7.....	\$ 28.65	29.75

GROUP 8.....	\$ 34.20	29.75
GROUP 9.....	\$ 34.28	29.75

a. FOOTNOTE: a. Any employee who works three days in the week in which a holiday falls shall be paid for the holiday.

a. PAID HOLIDAYS: New Year's Day, President's Day, Memorial Day, July Fourth, Victory Day, Labor Day, Columbus Day, Veterans Day, Thanksgiving Day & Christmas Day.

POWER EQUIPMENT OPERATOR CLASSIFICATIONS

GROUP 1: Digging machine, crane, piledriver, lighter, locomotive, derrick, hoist, boom truck, John Henry's, directional drilling machine, cold planer, reclaimer, paver, spreader, grader, front end loader (3 yds. and over), vacuum truck, test boring machine operator, veemere saw, water blaster, hydro-demolition robot, forklift, economobile, Ross Carrier, concrete pump operator and boats

GROUP 2: Well point installation crew

GROUP 3: Utility engineers and signal persons

GROUP 4: Oiler on cranes

GROUP 5: Combination loader backhoe, front end loader (less than 3 yds.), forklift, bulldozers & scrapers and boats

GROUP 6: Roller, skid steer loaders, street sweeper

GROUP 7: Gas and electric drive heater, concrete mixer, light plant, welding machine, pump & compressor

GROUP 8: Stone crusher

GROUP 9: Mechanic & welder

 ENGI0057-003 12/01/2023

BUILDING CONSTRUCTION

	Rates	Fringes
Power Equipment Operator		
GROUP 1.....	\$ 46.07	29.75
GROUP 2.....	\$ 44.07	29.75
GROUP 3.....	\$ 42.60	29.75
GROUP 4.....	\$ 39.85	29.75

GROUP 5.....	\$ 37.00	29.75
GROUP 6.....	\$ 43.15	29.75
GROUP 7.....	\$ 42.72	29.75
GROUP 8.....	\$ 40.04	29.75

a. BOOM LENGTHS, INCLUDING JIBS:

- 150 ft. and over: + \$ 2.00
- 180 ft. and over: + \$ 3.00
- 210 ft. and over: + \$ 4.00
- 240 ft. and over: + \$ 5.00
- 270 ft. and over: + \$ 7.00
- 300 ft. and over: + \$ 8.00
- 350 ft. and over: + \$ 9.00
- 400 ft. and over: + \$10.00

a. PAID HOLIDAYS: New Year's Day, President's Day, Memorial Day, July Fourth, Victory Day, Labor Day, Columbus Day, Veterans Day, Thanksgiving Day & Christmas Day. a: Any employee who works 3 days in the week in which a holiday falls shall be paid for the holiday.

- a. FOOTNOTE: Hazmat work: \$2.00 per hour additional.
Tunnel/Shaft work: \$5.00 per hour additional.

POWER EQUIPMENT OPERATORS CLASSIFICATIONS

GROUP 1: Cranes, lighters, boom trucks and derricks.

GROUP 2: Digging machine, Ross carrier, locomotive, hoist, elevator, bidwell-type machine, shot & water blasting machine, paver, spreader, front end loader (3 yds. and over), vibratory hammer and vacuum truck

GROUP 3: Telehandler equipment, forklift, concrete pump & on-site concrete plant

GROUP 4: Fireman & oiler on cranes

GROUP 5: Oiler on crawler backhoe

GROUP 6: Bulldozer, skid steer loaders, bobcats, tractor, grader, scraper, combination loader backhoe, roller, front end loader (less than 3 yds.), street and mobile powered sweeper (3 yds. capacity), 8-ft. sweeper (minimum 65 hp)

GROUP 7: Well point installation crew

GROUP 8: Heater, concrete mixer, stone crusher, welding machine, generator for light plant, gas and electric driven

pump & air compressor

 IRON0037-001 09/16/2023

	Rates	Fringes
IRONWORKER.....	\$ 40.00	32.58

 LABO0271-001 11/27/2022

BUILDING CONSTRUCTION

	Rates	Fringes
LABORER		
GROUP 1.....	\$ 35.50	26.85
GROUP 2.....	\$ 35.75	26.85
GROUP 3.....	\$ 36.25	26.85
GROUP 4.....	\$ 36.50	26.85
GROUP 5.....	\$ 37.50	26.85

LABORERS CLASSIFICATIONS

GROUP 1: Laborer, Carpenter Tender, Mason Tender, Cement Finisher Tender, Scaffold Erector, Wrecking Laborer, Asbestos Removal [Non-Mechanical Systems]

GROUP 2: Asphalt Raker, Adzemen, Pipe Trench Bracer, Demolition Burner, Chain Saw Operator, Fence & Guard Rail Erector, Setter of Metal Forms for Roadways, Mortar Mixer, Pipelayer, Riprap & Dry Stonewall Builder, Highway Stone Spreader, Pneumatic Tool Operator, Wagon Drill Operator, Tree Trimmer, Barco-Type Jumping Tamper, Mechanical Grinder Operator

GROUP 3: Pre-Cast Floor & Roof Plank Erectors

GROUP 4: Air Track Operator, Hydraulic & Similar Self-Powered Drill, Block Paver, Rammer, Curb Setter, Powderman & Blaster

GROUP 5: Toxic Waste Remover

LABORERS CLASSIFICATIONS

GROUP 1: Laborer, Carpenter Tender, Mason Tender, Cement Finisher Tender, Scaffold Erector, Wrecking Laborer, Asbestos Removal [Non-Mechanical Systems]

GROUP 2: Asphalt Raker, Adzemen, Pipe Trench Bracer, Demolition Burner, Chain Saw Operator, Fence & Guard Rail Erector, Setter of Metal Forms for Roadways, Mortar Mixer,

Pipelayer, Riprap & Dry Stonewall Builder, Highway Stone Spreader, Pneumatic Tool Operator, Wagon Drill Operator, Tree Trimmer, Barco-Type Jumping Tamper, Mechanical Grinder Operator

GROUP 3: Pre-Cast Floor & Roof Plank Erectors

GROUP 4: Air Track Operator, Hydraulic & Similar Self-Powered Drill, Block Paver, Rammer, Curb Setter, Powderman & Blaster

GROUP 5: Toxic Waste Remover

 LABO0271-002 11/27/2022

HEAVY AND HIGHWAY CONSTRUCTION

	Rates	Fringes
LABORER		
COMPRESSED AIR		
Group 1.....	\$ 55.40	24.15
Group 2.....	\$ 52.93	24.15
Group 3.....	\$ 42.45	24.15
FREE AIR		
Group 1.....	\$ 44.05	24.15
Free Air		
Group 1.....	\$ 46.00	24.15
FREE AIR		
Group 2.....	\$ 43.05	24.15
Free Air		
Group 2.....	\$ 45.00	24.15
FREE AIR		
Group 3.....	\$ 40.50	24.15
Free Air		
Group 3.....	\$ 42.45	24.15
LABORER		
Group 1.....	\$ 35.50	24.85
Group 2.....	\$ 35.75	24.85
Group 3.....	\$ 36.50	24.85
Group 4.....	\$ 29.00	24.85
Group 5.....	\$ 37.50	24.85
OPEN AIR CAISSON, UNDERPINNING WORK AND BORING CREW		
Bottom Man.....	\$ 41.50	24.15
Top Man & Laborer.....	\$ 35.60	24.15
TEST BORING		
Driller.....	\$ 41.95	24.15
Laborer.....	\$ 41.95	24.15

LABORER CLASSIFICATIONS

GROUP 1: Laborer; Carpenter tender; Cement finisher tender; Wrecking laborer; Asbestos removers [non-mechanical systems]; Plant laborer; Driller in quarries

GROUP 2: Adzeperson; Asphalt raker; Barcotype jumping tamper; Chain saw operators; Concrete and power buggy operator; Concrete saw operator; Demolition burner; Fence and guard rail erector; Highway stone spreader; Laser beam operator; Mechanical grinder operator; Mason tender; Mortar mixer; Pneumatic tool operator; Riprap and dry stonewall builder; Scaffold erector; Setter of metal forms for roadways; Wagon drill operator; Wood chipper operator; Pipelayer; Pipe trench bracer

GROUP 3: Air track drill operator; Hydraulic and similar powered drills; Brick paver; Block paver; Rammer and curb setter; Powderperson and blaster

GROUP 4: Flagger & signaler

GROUP 5: Toxic waste remover

LABORER - COMPRESSED AIR CLASSIFICATIONS

GROUP 1: Mucking machine operator, tunnel laborer, brake person, track person, miner, grout person, lock tender, gauge tender, miner: motor person & all others in compressed air

GROUP 2: Change house attendant, powder watchperson, top person on iron

GROUP 3: Hazardous waste work within the "HOT" zone

LABORER - FREE AIR CLASSIFICATIONS

GROUP 1: Grout person - pumps, brake person, track person, form mover & stripper (wood & steel), shaft laborer, laborer topside, outside motorperson, miner, conveyor operator, miner welder, heading motorperson, erecting operator, mucking machine operator, nozzle person, rodperson, safety miner, shaft & tunnel, steel & rodperson, mole nipper, concrete worker, form erector (wood, steel and all accessories), cement finisher (this type of work only), top signal person, bottom person (when heading is 50' from shaft), burner, shield operator and TBM operator

GROUP 2: Change house attendant, powder watchperson

GROUP 3: Hazardous waste work within the ""HOT"" zone

LABORER CLASSIFICATIONS

GROUP 1: Laborer; Carpenter tender; Cement finisher tender; Wrecking laborer; Asbestos removers [non-mechanical systems]; Plant laborer; Driller in quarries

GROUP 2: Adzeperson; Asphalt raker; Barcotype jumping tamper; Chain saw operators; Concrete and power buggy operator; Concrete saw operator; Demolition burner; Fence and guard rail erector; Highway stone spreader; Laser beam operator; Mechanical grinder operator; Mason tender; Mortar mixer; Pneumatic tool operator; Riprap and dry stonewall builder; Scaffold erector; Setter of metal forms for roadways; Wagon drill operator; Wood chipper operator; Pipelayer; Pipe trench bracer

GROUP 3: Air track drill operator; Hydraulic and similar powered drills; Brick paver; Block paver; Rammer and curb setter; Powderperson and blaster

GROUP 4: Flagger & signaler

GROUP 5: Toxic waste remover

LABORER - COMPRESSED AIR CLASSIFICATIONS

GROUP 1: Mucking machine operator, tunnel laborer, brake person, track person, miner, grout person, lock tender, gauge tender, miner: motor person & all others in compressed air

GROUP 2: Change house attendant, powder watchperson, top person on iron

GROUP 3: Hazardous waste work within the ""HOT"" zone

LABORER - FREE AIR CLASSIFICATIONS

GROUP 1: Grout person - pumps, brake person, track person, form mover & stripper (wood & steel), shaft laborer, laborer topside, outside motorperson, miner, conveyor operator, miner welder, heading motorperson, erecting operator, mucking machine operator, nozzle person, rodperson, safety miner, shaft & tunnel, steel & rodperson, mole nipper, concrete worker, form erector (wood, steel and all accessories), cement finisher (this type of work only), top signal person, bottom person (when heading is 50' from shaft), burner, shield operator and TBM operator

GROUP 2: Change house attendant, powder watchperson

GROUP 3: Hazardous waste work within the ""HOT"" zone

PAIN0011-005 06/01/2023

	Rates	Fringes
PAINTER		
Brush and Roller.....	\$ 37.62	22.85
Epoxy, Tanks, Towers, Swing Stage & Structural Steel.....	\$ 39.62	22.85
Spray, Sand & Water Blasting.....	\$ 40.62	22.85
Taper.....	\$ 38.37	22.85
Wall Coverer.....	\$ 38.12	22.85

PAIN0011-006 06/01/2022

	Rates	Fringes
GLAZIER.....	\$ 40.78	23.40

FOOTNOTES:

SWING STAGE: \$1.00 per hour additional.

PAID HOLIDAYS: Labor Day & Christmas Day.

PAIN0011-011 06/01/2023

	Rates	Fringes
Painter (Bridge Work).....	\$ 56.25	23.45

PAIN0035-008 06/01/2011

	Rates	Fringes
Sign Painter.....	\$ 24.79	13.72

PLAS0040-001 01/01/2024

BUILDING CONSTRUCTION

	Rates	Fringes
--	-------	---------

CEMENT MASON/CONCRETE FINISHER...\$ 43.00 29.10

FOOTNOTE: Cement Mason: Work on free swinging scaffolds under 3 planks width and which is 20 or more feet above ground and any offset structure: \$.30 per hour additional.

 PLAS0040-002 01/01/2024

HEAVY AND HIGHWAY CONSTRUCTION

	Rates	Fringes
CEMENT MASON/CONCRETE FINISHER...	\$ 38.45	25.30

 PLAS0040-003 01/01/2024

	Rates	Fringes
PLASTERER.....	\$ 43.65	29.43

 PLUM0051-002 08/28/2023

	Rates	Fringes
Plumbers and Pipefitters.....	\$ 50.59	32.75

 ROOF0033-004 12/01/2023

	Rates	Fringes
ROOFER.....	\$ 43.80	30.31

 * SFRI0669-001 04/01/2024

	Rates	Fringes
SPRINKLER FITTER.....	\$ 49.98	32.85

 SHEE0017-002 12/01/2020

	Rates	Fringes
Sheet Metal Worker.....	\$ 38.58	36.73

 TEAM0251-001 05/01/2023

HEAVY AND HIGHWAY CONSTRUCTION

	Rates	Fringes
TRUCK DRIVER		
GROUP 1.....	\$ 29.71	34.602+A+B
GROUP 2.....	\$ 29.86	34.602+A+B
GROUP 3.....	\$ 29.91	34.602+A+B
GROUP 4.....	\$ 29.96	34.602+A+B
GROUP 5.....	\$ 30.06	34.602+A+B
GROUP 6.....	\$ 30.46	34.602+A+B
GROUP 7.....	\$ 30.66	34.602+A+B
GROUP 8.....	\$ 30.16	34.602+A+B
GROUP 9.....	\$ 30.41	34.602+A+B
GROUP 10.....	\$ 30.21	34.602+A+B

FOOTNOTES:

A. Paid Holidays: New Year's Day, Memorial Day, Independence Day, Labor Day, Thanksgiving Day and Christmas Day, plus Presidents' Day, Columbus Day, Veteran's Day & V-J Day, providing the employee has worked at least one day in the calendar week in which the holiday falls.

B. Employee who has been on the payroll for 1 year or more but less than 5 years and has worked 150 Days during the last year of employment shall receive 1 week's paid vacation; 5 to 10 years - 2 weeks' paid vacation; 10 or more years - 3 week's paid vacation.

C. Employees on the seniority list shall be paid a one hundred dollar (\$100.00) bonus for every four hundred (400) hours worked, up to a maximum of five hundred dollars (\$500.00)

All drivers working on a defined hazard material job site shall be paid a premium of \$2.00 per hour over applicable rate.

TRUCK DRIVER CLASSIFICATIONS

GROUP 1: Pick-up trucks, station wagons, & panel trucks

GROUP 2: Two-axle on low beds

GROUP 3: Two-axle dump truck

GROUP 4: Three-axle dump truck

GROUP 5: Four- and five-axle equipment

GROUP 6: Low-bed or boom trailer.

GROUP 7: Trailers when used on a double hook up (pulling 2 trailers)

GROUP 8: Special earth-moving equipment, under 35 tons

GROUP 9: Special earth-moving equipment, 35 tons or over

GROUP 10: Tractor trailer

WELDERS - Receive rate prescribed for craft performing operation to which welding is incidental.

=====
Note: Executive Order (EO) 13706, Establishing Paid Sick Leave for Federal Contractors applies to all contracts subject to the Davis-Bacon Act for which the contract is awarded (and any solicitation was issued) on or after January 1, 2017. If this contract is covered by the EO, the contractor must provide employees with 1 hour of paid sick leave for every 30 hours they work, up to 56 hours of paid sick leave each year. Employees must be permitted to use paid sick leave for their own illness, injury or other health-related needs, including preventive care; to assist a family member (or person who is like family to the employee) who is ill, injured, or has other health-related needs, including preventive care; or for reasons resulting from, or to assist a family member (or person who is like family to the employee) who is a victim of, domestic violence, sexual assault, or stalking. Additional information on contractor requirements and worker protections under the EO is available at <https://www.dol.gov/agencies/whd/government-contracts>.

Unlisted classifications needed for work not included within the scope of the classifications listed may be added after award only as provided in the labor standards contract clauses (29CFR 5.5 (a) (1) (iii)).

The body of each wage determination lists the classification and wage rates that have been found to be prevailing for the cited type(s) of construction in the area covered by the wage determination. The classifications are listed in alphabetical order of ""identifiers"" that indicate whether the particular rate is a union rate (current union negotiated rate for local), a survey rate (weighted average rate) or a union average rate

(weighted union average rate).

Union Rate Identifiers

A four letter classification abbreviation identifier enclosed in dotted lines beginning with characters other than ""SU"" or ""UAVG"" denotes that the union classification and rate were prevailing for that classification in the survey. Example: PLUM0198-005 07/01/2014. PLUM is an abbreviation identifier of the union which prevailed in the survey for this classification, which in this example would be Plumbers. 0198 indicates the local union number or district council number where applicable, i.e., Plumbers Local 0198. The next number, 005 in the example, is an internal number used in processing the wage determination. 07/01/2014 is the effective date of the most current negotiated rate, which in this example is July 1, 2014.

Union prevailing wage rates are updated to reflect all rate changes in the collective bargaining agreement (CBA) governing this classification and rate.

Survey Rate Identifiers

Classifications listed under the ""SU"" identifier indicate that no one rate prevailed for this classification in the survey and the published rate is derived by computing a weighted average rate based on all the rates reported in the survey for that classification. As this weighted average rate includes all rates reported in the survey, it may include both union and non-union rates. Example: SULA2012-007 5/13/2014. SU indicates the rates are survey rates based on a weighted average calculation of rates and are not majority rates. LA indicates the State of Louisiana. 2012 is the year of survey on which these classifications and rates are based. The next number, 007 in the example, is an internal number used in producing the wage determination. 5/13/2014 indicates the survey completion date for the classifications and rates under that identifier.

Survey wage rates are not updated and remain in effect until a new survey is conducted.

Union Average Rate Identifiers

Classification(s) listed under the UAVG identifier indicate that no single majority rate prevailed for those classifications; however, 100% of the data reported for the classifications was union data. EXAMPLE: UAVG-OH-0010 08/29/2014. UAVG indicates that the rate is a weighted union average rate. OH indicates the state. The next number, 0010 in

the example, is an internal number used in producing the wage determination. 08/29/2014 indicates the survey completion date for the classifications and rates under that identifier.

A UAVG rate will be updated once a year, usually in January of each year, to reflect a weighted average of the current negotiated/CBA rate of the union locals from which the rate is based.

WAGE DETERMINATION APPEALS PROCESS

1.) Has there been an initial decision in the matter? This can be:

- * an existing published wage determination
- * a survey underlying a wage determination
- * a Wage and Hour Division letter setting forth a position on a wage determination matter
- * a conformance (additional classification and rate) ruling

On survey related matters, initial contact, including requests for summaries of surveys, should be with the Wage and Hour National Office because National Office has responsibility for the Davis-Bacon survey program. If the response from this initial contact is not satisfactory, then the process described in 2.) and 3.) should be followed.

With regard to any other matter not yet ripe for the formal process described here, initial contact should be with the Branch of Construction Wage Determinations. Write to:

Branch of Construction Wage Determinations
Wage and Hour Division
U.S. Department of Labor
200 Constitution Avenue, N.W.
Washington, DC 20210

2.) If the answer to the question in 1.) is yes, then an interested party (those affected by the action) can request review and reconsideration from the Wage and Hour Administrator (See 29 CFR Part 1.8 and 29 CFR Part 7). Write to:

Wage and Hour Administrator
U.S. Department of Labor
200 Constitution Avenue, N.W.
Washington, DC 20210

The request should be accompanied by a full statement of the

interested party's position and by any information (wage payment data, project description, area practice material, etc.) that the requestor considers relevant to the issue.

3.) If the decision of the Administrator is not favorable, an interested party may appeal directly to the Administrative Review Board (formerly the Wage Appeals Board). Write to:

Administrative Review Board
U.S. Department of Labor
200 Constitution Avenue, N.W.
Washington, DC 20210

4.) All decisions by the Administrative Review Board are final.

=====

END OF GENERAL DECISION"

END OF DOCUMENT

THIS PAGE INTENTIONALLY LEFT BLANK

SECTION 01 10 00

SUMMARY OF WORK

PART 1 - GENERAL

1.01 SECTION INCLUDES

- A. Contract description.
- B. Work by Owner.
- C. Owner supplied products.
- D. Contractor's use of site and premises.
- E. Owner occupancy.
- F. Definitions

1.02 CONTRACT DESCRIPTION

- A. Work of the Project includes the construction of a new Education Center and Event Pavilion as described on the drawings and in this project manual.
- B. Perform the Work of the Contract under a stipulated sum Contract with the Owner in accordance with the Conditions of Contract.
- C. The Work of the Contract is identified in the Project Manual and on the Drawings.

1.03 WORK BY OWNER

- A. The Owner has awarded a contract to prepare the site for the work on these two buildings as noted in these documents. The work is mostly complete at the time of the release of this Bid.

1.04 OWNER SUPPLIED PRODUCTS

- A. Owner's Responsibilities:
 - 1. Arrange for and deliver Owner-reviewed Shop Drawings, Product Data, and Samples, to the Contractor.
 - 2. Arrange and pay for delivery to the site.
 - 3. On delivery, inspect products jointly with the Contractor.
 - 4. Submit claims for transportation damage and replace damaged, defective, or deficient items.
 - 5. Arrange for manufacturers' warranties, inspections, and service.
- B. Contractor's Responsibilities:
 - 1. Review Owner-reviewed Shop Drawings, Product Data, and Samples.
 - 2. Receive and unload products at the site; inspect for completeness or damage jointly with the Owner.
 - 3. Handle, store, install and finish products.

4. Repair or replace items damaged after receipt.

C. Items furnished by the Owner for installation by the Contractor:

1. Various Appliances and furniture. (See drawings for quantities and locations)

1.05 CONTRACTOR'S USE OF SITE AND PREMISES

A. Limit use of the site and premises to allow:

1. Use of the surrounding site and premises by the Owner and public.

B. Construction Personnel Conduct

1. The following conduct by construction personnel will not be tolerated on the Owner's property, violators may be ejected from the site.

a. NO SMOKING is allowed. The Contractor will erect signs noting such at all entrances.

b. No drugs or alcohol are allowed

c. No firearms or weapons are allowed.

d. No foul language will be tolerated.

e. No fighting. All involved will be subject to being removed from the site.

C. On-Site Work Hours:

1. Work shall be generally performed during normal business working hours of 7:00 A.M. to 5:00 P.M., Monday through Friday, except otherwise indicated.

2. Weekend Hours: 7:00 A.M. to 5:00 P.M. Saturday or Sunday with written permission from the Owner

3. All exceptionally noisy work is restricted to between 9 A.M. and 5 P.M.

4. Holiday Hours: No work shall be permitted on major holidays.

1.06 OWNER OCCUPANCY

A. The Owner intends to occupy the site outside of the Project Limit Line.

B. Cooperate with the Owner to minimize conflict, and to facilitate the Owner's operations.

1.07 DEFINITIONS

A. Basic Contract definitions are included below.

1. "Approved": When used to convey Architect's action on Contractor's submittals, applications, and requests, "approved" is limited to Architect's duties and responsibilities as stated in the Conditions of the Contract.

2. "Directed": A command or instruction by Architect. . Other terms including "requested," "authorized," "selected," "approved," "required," and "permitted" have the same meaning as "directed."

3. "Indicated": Requirements expressed by graphic representations or in written form on Drawings, in Specifications, and in other Contract Documents. Other terms including "shown," "noted," "scheduled," and "specified" have the same meaning as "indicated."
4. "Regulations": Laws, ordinances, statutes, and lawful orders issued by authorities having jurisdiction, and rules, conventions, and agreements within the construction industry that control performance of the Work.
5. "Furnish": Supply and deliver to Project site, ready for unloading, unpacking, assembly, installation, and similar operations.
6. "Install": Operations at Project site including unloading, temporarily storing, unpacking, disposing of packaging, assembling, erecting, placing, anchoring, applying, working to dimension, finishing, curing, protecting, cleaning, and similar operations.
7. "Provide": Furnish and install, complete, in place, and ready for the intended use.
8. "Project Site": Space available for performing construction activities. The extent of Project site is shown on Drawings.

PART 2 - PRODUCTS

Not Used.

PART 3 - EXECUTION

Not Used.

END OF SECTION

THIS PAGE INTENTIONALLY LEFT BLANK

SECTION 01 10 13

INFORMATION AVAILABLE TO BIDDERS

1. GEOTECHNICAL DATA

- A. A copy of the Geotechnical Data with respect to the project site is included following this page.
- B. Set of drawings showing site work by the Owner for a previous project in preparation for the Education Center & Events Pavilion project.

THIS PAGE INTENTIONALLY LEFT BLANK



LGCI

Lahlaf Geotechnical Consulting, Inc.

December 3, 2019

Mr. Francois Karam,
Saccoccio & Associates, Inc.
1085 Park Avenue
Cranston, Rhode Island 02910
Phone: (401) 942-7970 Ext. 312
Fax: (401) 942-7975
E-mail: francois@sa-architects.com

Re: **Geotechnical Report
Proposed Education Center and Event Pavilion
Roger William Park Zoo
Providence, Rhode Island
LGCI Project No. 1911**

Dear Mr. Karam:

Lahlaf Geotechnical Consulting, Inc. (LGCI) has completed a geotechnical study for the proposed Education Center and Event Pavilion at the Roger Williams Park Zoo (RWPZ) in Providence, Rhode Island. We are submitting this report electronically, please notify us if you need a hard copy.

The soil samples from our explorations are currently stored at LGCI for further analysis, if requested. Unless notified otherwise, we will dispose of the soil samples after three months.

Thank you for choosing LGCI as your geotechnical engineer.

Very truly yours,

Lahlaf Geotechnical Consulting, Inc.

Abdelmadjid M. Lahlaf, Ph.D., P.E.
Principal Engineer



LGCI

Lahlaf Geotechnical Consulting, Inc.

**GEOTECHNICAL REPORT
PROPOSED EDUCATION CENTER AND EVENT PAVILION
ROGER WILLIAMS PARK ZOO
PROVIDENCE, RHODE ISLAND
LGCI Project No. 1911
December 3, 2019**

Prepared for:

SACCOCCIO & ASSOCIATES, INC.
1085 Park Avenue
Cranston, Rhode Island 02910
Phone: (401) 942-7970 Ext. 312
Fax: (401) 942-7975

**GEOTECHNICAL REPORT
PROPOSED EDUCATION CENTER AND EVENT PAVILION
ROGER WILLIAMS PARK ZOO
PROVIDENCE, RHODE ISLAND**

LGCI Project No. 1911
December 3, 2019

Prepared for:

SACCOCCIO & ASSOCIATES, INC.

1085 Park Avenue
Cranston, RI 02190
Phone: (401) 942-7970 Ext. 312
Fax: (401) 942-7970

Prepared by:

LAHLAF GEOTECHNICAL CONSULTING, INC.

100 Chelmsford Road, Suite 2
Billerica, Massachusetts 01862
Phone: (978) 330-5912
Fax: (978) 330-5056



Abdelmadjid M. Lahlaf, Ph.D., P.E.
Principal Engineer

TABLE OF CONTENTS

1.	PROJECT INFORMATION	1
1.1	PROJECT AUTHORIZATION	1
1.2	PURPOSE AND SCOPE OF SERVICES	1
1.3	SITE DESCRIPTION	2
1.4	PROJECT DESCRIPTION	2
1.5	ELEVATION DATUM.....	4
2.	SITE AND SUBSURFACE CONDITIONS	5
2.1	SURFICIAL GEOLOGY	5
2.2	PREVIOUS BORINGS	5
2.3	LGCI'S TEST PITS AND BORINGS	5
2.3.1	<i>General</i>	5
2.3.2	<i>LGCI Explorations</i>	6
2.3.2.1	Test Pits.....	6
2.3.2.2	Soil Borings	6
2.3.3	<i>Test Pit and Boring Logs and Locations</i>	6
2.4	SUBSURFACE CONDITIONS	7
2.5	GROUNDWATER.....	9
2.6	LABORATORY TEST DATA.....	9
3.	EVALUATION AND RECOMMENDATIONS.....	10
3.1	GENERAL.....	10
3.1.1	<i>Existing Fill and Surficial and Buried Organic Soil</i>	10
3.1.2	<i>Foundation Recommendations</i>	10
3.2	GROUND IMPROVEMENTS.....	10
3.2.1	<i>General</i>	10
3.2.2	<i>Aggregate Piers</i>	11
3.2.3	<i>Site Preparation for Aggregate Piers</i>	12
3.2.4	<i>Protection of APs</i>	12
3.3	FOOTING DESIGN.....	12
3.4	SETTLEMENT UNDER STATIC LOAD	13
3.5	CONCRETE SLAB CONSIDERATIONS.....	13
3.6	UNDER-SLAB DRAINS	14
3.7	RETAINING WALL.....	14
3.7.1	<i>Lateral Earth Pressures</i>	14
3.7.2	<i>Wall Drains</i>	15
3.8	SEISMIC DESIGN	16
3.8.1	<i>Seismic Design Parameters</i>	16
3.8.2	<i>Liquefaction Potential</i>	16
3.8.3	<i>Earthquake Induced Settlement</i>	16
3.8.4	<i>Seismic Ties for Footings</i>	16
3.9	UNDERGROUND UTILITIES.....	17
3.10	SIDEWALKS	17
4.	CONSTRUCTION CONSIDERATIONS	18
4.1	SUBGRADE PREPARATION	18
4.2	SUBGRADE PROTECTION.....	19
4.3	FILL MATERIALS	19
4.3.1	<i>Structural Fill</i>	20
4.3.2	<i>Ordinary Fill</i>	20
4.4	REUSE OF ONSITE MATERIALS	20
4.5	GROUNDWATER CONTROL PROCEDURES	21
4.6	TEMPORARY EXCAVATIONS	21



5. **RECOMMENDATIONS FOR FUTURE WORK**..... 22

6. **REPORT LIMITATIONS** 23

7. **REFERENCES**..... 24



TABLE OF CONTENTS (CONTINUED)

LIST OF FIGURES AND TABLES

Table 1	Summary of LGCI's Test Pits
Table 2	Summary of LGCI's Borings
Figure 1	Site Location Map
Figure 2	Surficial Geologic Map
Figure 3	Boring Location Plan

LIST OF APPENDICES

Appendix A	Logs of LGCI's Previous Boring
Appendix B	LGCI's Test Pit Logs
Appendix C	LGCI's Boring Logs
Appendix D	Laboratory Test Results



**Geotechnical Report
Proposed Education Center and Event Pavilion
Roger Williams Park Zoo
Providence, Rhode Island
LGCI Project No. 1911**

1. PROJECT INFORMATION

1.1 Project Authorization

This geotechnical report presents the results of subsurface explorations and a geotechnical evaluation performed by Lahlaf Geotechnical Consulting, Inc. (LGCI) for the proposed Education Center and Event Pavilion at Roger Williams Park Zoo (RWPZ) in Providence, Rhode Island. We performed our services in general accordance with proposal No. 19047 dated May 22, 2019. Mr. Mark Saccoccio of Saccoccio & Associates, Inc. (SAI) authorized our services by signing our proposal on May 24, 2019.

1.2 Purpose and Scope of Services

The purpose of this geotechnical study was to obtain subsurface information at the proposed building site and to provide foundation design and construction recommendations. LGCI performed the following services:

- Coordinated the test pit and boring locations with SAI, with the Roger William Park Zoo (RWPZ) staff, and with Garofalo & Associates Inc. of Providence Rhode Islands (the project civil engineer).
- Marked our test pit and boring locations at the site in the presence of a representative of RWPZ.
- Engaged an excavation subcontractor to excavate four (4) test pits at the site. We also engaged a drilling subcontractor to advance seven (7) soil borings at the site. Our drilling/excavation subcontractor coordinated the utility clearance for our test pits and borings.
- Provided an LGCI geotechnical engineer to observe the test pits and borings, describe the soil samples, and prepare field logs.
- Submitted two (2) soil samples for laboratory testing.
- Prepared this geotechnical report containing the results of our subsurface exploration and our recommendations for foundation design and construction.

In addition to the services described above, our proposal (listed in Section 1.1) included preparing earth moving specifications and ground improvement specifications. Our scope does not include attending meetings, reviewing drawings, or providing construction services. LGCI would be pleased to perform these services when needed. Recommendations for stormwater management, erosion control, pavement design, slope stability analyses, liquefaction analysis, seismic settlement, and detailed cost or quantity estimates are not included in our scope of work.



**Geotechnical Report
Proposed Education Center and Event Pavilion
Roger Williams Park Zoo
Providence, Rhode Island
LGCI Project No. 1911**

LGCI did not perform environmental services for this project. LGCI did not perform an assessment to evaluate for the presence or absence of hazardous or toxic materials above or below the ground surface at or around the site. Any statement about the color, odor, or the presence of suspicious materials included in our boring logs or report were made by LGCI for information only and to support our geotechnical services. No environmental recommendations and/or opinions are included in this report.

1.3 Site Description

LGCI's understanding of the site is based on our observations at the site, our discussion with SAI, and on the following drawing:

- Drawing C-1.4 titled: "Grading & Drainage Plan, Education Center & Pavilion, Roger William Park Zoo," (Grading Plan) prepared by Garofalo & Associates, Inc. and dated June 13, 2019.

RWPZ is located at 1000 Elmwood Avenue in Providence, Rhode Island. The sites of the proposed Education Center and Event Pavilion are located near the main entrance of RWPZ as shown in Figure 1. The proposed Education Center will be located in the currently wooded area north of the main parking lot just west of the main zoo entrance. The site of the proposed Education Center will be bordered by the walkway that separates it from the Zebra/Wildebeest and Cheetah exhibits on the northern side, by the existing greenhouse and visitor center on the western side, and by the ticketing building at the main entrance on the eastern side. The site of the proposed Event Pavilion is located within the existing Aoudad exhibit west of the proposed Education Center. It is bordered by a walkway on the northern and western sides, by Polo Lake on the southern side, and by the existing greenhouse and visitor center on the on the eastern side.

The site is generally sloped and the grades generally drop from the main entrance toward the Aoudad Exhibit. Based on the Grading Plan, the existing grade within the proposed Education Center rises from about El. 42 feet in the existing parking lot to a ridge at about El. 45 feet with a local low at El. 39 feet, then drops to the walkway north of the proposed Education Center footprint at El. 34 to 36 feet. The existing grade within the proposed Event Pavilion drops in a southerly direction from about El. 37 feet to about El. 28 feet with a local high at about El. 40 feet near the center of the current Aoudad Exhibit.

1.4 Project Description

Our understanding of the proposed construction is based on our phone and e-mail communications with representatives of Roger Williams Park Zoo, discussions with SAI, the Grading Plan referenced in Section 1.3, and on the following drawing:

- Drawing C-1.3 titled: "Site Plan, Education Center & Pavilion, Roger William Park Zoo," (Site Plan) prepared by Garofalo & Associates, Inc. dated June 13, 2019.



**Geotechnical Report
Proposed Education Center and Event Pavilion
Roger Williams Park Zoo
Providence, Rhode Island
LGCI Project No. 1911**

We understand that SAI was engaged to design the proposed Education Center and proposed Event Pavilion.

Based on the Grading Plan and the Site Plan, the proposed Education Center will be located east of the existing visitor's center which will remain, and will overlap with the existing greenhouse, shed, and a portion of the existing parking lot. The existing greenhouse and the shed will be demolished to allow for the proposed construction. We understand that the proposed Education Center will have a footprint of about 12,600 square feet and will not have a basement. We understand that the proposed Education Center will be a two-story structure with the first floor extending north past the second floor. The first floor will have a Finished Floor Elevation (FFE) of El. 34 feet and will be at grade with and accessible from the existing ground surface on the northern side near the walkway. The second floor will extend past the first floor south towards the existing parking lot and will have an FFE of El. 46 feet. The second floor will be at grade with and accessible from the existing parking lot. The proposed construction will also include two retaining walls that will be located on the western side of the proposed building. Based on the Grading Plan, the proposed retaining walls will have exposed heights of up to 7.5 feet high.

Based on the Grading Plan and Site Plan, the proposed Event Pavilion will be located north of Polo Lake and will be located mostly within the existing Aoudad exhibit. The existing single-story house, located within the Aoudad Exhibit, will be demolished to allow for the proposed construction. The proposed Event Pavilion will have a footprint of about 9,350 square feet. We understand that the Event Pavilion will not have a basement and will a one-story structure with an FFE of El. 35.5 feet.

Based on the Site Plan, three proposed playground areas will be provided north of the proposed Education Center. The existing bus shelter will be relocated east of the proposed Education Center. A concrete pathway will lead into the RWPZ west of the proposed Education Center. A concrete pathway located west of the proposed Education Center will expand into the existing parking which will be improved.

Based on the Grading Plan, cuts of up to 11 feet will be required near the center of the footprint of the proposed Education Center to achieve the proposed FFE of El. 34 feet. Fill of up to 7 feet will be required on the northern and western sides of the proposed Education Center to achieve the proposed FFE of 46 feet. Based on the Grading Plan, cuts and fill of up to 8 feet will be required to achieve the proposed grades surrounding the proposed Education Center. In the proposed Event Pavilion, cuts and fill of up to 6 feet will be required to achieve the proposed FFE of 35.5 feet. Minor cuts and fill will be required to achieve the proposed grade surrounding the proposed Event Pavilion except in the southern side where cuts of up to 6 feet will be required.

Information about the proposed column loads is not available.



**Geotechnical Report
Proposed Education Center and Event Pavilion
Roger Williams Park Zoo
Providence, Rhode Island
LGCI Project No. 1911**

1.5 Elevation Datum

The elevations shown in Grading Plan and Site Plan are referenced to the North American Vertical Datum of 1988 (NAVD 1988).



2. SITE AND SUBSURFACE CONDITIONS

2.1 Surficial Geology

LGCI reviewed the map titled: “Geologic Map of Providence Quadrangle, Rhode Island, Surficial Geology,” published in 1956 and prepared by J. Hiram Smith.

The surficial geologic map indicates that the soils within the general area of the site are comprised of sands deposited as outwash plains from glacial melt-water streams. The surficial geologic map of the site is shown in Figure 2.

2.2 Previous Borings

As part of LGCI previous explorations for the existing veterinary hospital and children’s zoo, LGCI conducted two (2) borings B-204 to B-205 advanced in the general area of the proposed Education Center and Event Pavilion in 2009. Boring B-204 and B-205 extended to depths of 41 and 17 feet beneath the ground surface, respectively. Borings B-204 and B-205 were advanced using drive and wash with a 4-inch casing and 4-1/4- inch hollow stem augers, respectively.

Borings B-204 and B-205 generally indicated fill extending to depths ranging between 4.5 and 7.2 feet beneath the ground surface, overlying peat that extended to depths of 7 and 9 feet beneath the ground surface, respectively. Natural, very loose to medium dense sand was encountered beneath the fill or peat in the borings and extended to the boring termination depths.

The logs of borings B-204 and B-205 are included in Appendix A, and the locations of borings B-204 and B-205 are shown in Figure 3.

2.3 LGCI’s Test Pits and Borings

2.3.1 General

LGCI coordinated our exploration locations with SAI and marked the exploration locations in the field by taping distances from the proposed building corners staked by the project surveyor. Our drilling subcontractor notified Dig Safe and the City of Providence for utility clearance and coordinated the clearance of private utilities with RWPZ staff prior to starting our explorations at the site.

Unless notified otherwise, we will dispose of the soil samples obtained during our explorations after three months.



2.3.2 LGCI Explorations

2.3.2.1 Test Pits

LGCI engaged Hoffman Environmental Services (HES) of North Kingston, Rhode Island to excavate four (4) test pits (TP-1 to TP-4) at the site on August 7, 2019. Test pits TP-1 to TP-3 were advanced at the location of the proposed Education Center and test pit TP-4 was excavated near the location of the proposed Event Pavilion at the request of Garofalo & Associates Inc. The test pits were excavated with a CAT 303.5 and extended to depths ranging between 7.5 and 8.5 feet beneath the ground surface.

An LGCI engineer observed and logged the test pits in the field.

Upon completion, the test pit excavations were backfilled with the excavated material which was placed in about 18-inch lifts and tamped with the excavator bucket.

2.3.2.2 Soil Borings

LGCI engaged HES to advance seven (7) boring (B-1 to B-7) at the site between August 6 and August 12, 2019. The borings were advanced with a track-mounted Diedrich D-25 ATV drill rig using 4-1/4-inch hollow stem auger (HSA) for borings B-1 and B-3, and drive and wash technique with a 3-inch or 4-inch casing for boring B-2 and B-4 to B-7. Boring B-1 to B-5 were advanced within the footprint of the proposed Education Center and borings B-6 and B-7 were advanced within the footprint of the proposed Event Pavilion. The borings extended to depths ranging between 22 and 52 feet beneath the ground surface. Upon completion, the boreholes were backfilled with the soil cuttings.

An LGCI engineer observed and logged the borings in the field.

HES performed Standard Penetration Tests (SPT) during drilling and obtained split spoon samples in the borings with an automatic hammer at typical depth intervals of 2 feet or 5 feet as noted on the boring logs in general accordance with ASTM D-1586.

2.3.3 Test Pit and Boring Logs and Locations

The test pit and boring locations are shown in Figure 3. Appendix B contains LGCI's test pits logs. Appendix C contains LGCI's boring logs. Tables 1 and 2 show a summary of LGCI's test pits and borings, respectively.

The ground surface elevations included in the test pit and boring logs were interpolated to the nearest foot from the Grading Plan. Please note that our test pit and boring locations were located using taped measurements and were not surveyed. Therefore, our test pit and boring locations and our interpolated elevations are approximate.



2.4 Subsurface Conditions

The subsurface descriptions in this report are based on a limited number of test pits and borings and are intended to highlight the major soil strata encountered during our explorations. The subsurface conditions are known only at the actual exploration locations. Variations may occur and should be expected between exploration locations. The exploration logs represent conditions that we observed at the time of our explorations and were edited, as appropriate, based on the inspection of the soil samples in the laboratory. The strata boundaries shown in our exploration logs are based on our interpretations and the actual transition may be gradual. Graphic soil symbols are for illustration only.

The soil strata encountered in the test pits and borings were as follows, starting at the ground surface.

Proposed Education Center (Borings B-1 to B-5 and test pits TP-1 to TP-3)

Asphalt – A layer of asphalt was encountered at the ground surface in boring B-3. The asphalt was 6 inches thick.

Forest Mat and Topsoil – A layer of surficial organic topsoil and/or forest mat was encountered at the ground surface in test pits TP-1 to TP-3 and in borings B-1, B-2, B-4 and B-5. This layer extended to depths ranging between 0.2 and 0.6 feet beneath ground surface.

Subsoil – A layer of subsoil was encountered beneath the forest mat/topsoil layer in test pits TP-1 to TP-3. This layer extended to depths ranging between 0.7 and 0.9 feet beneath the ground surface. The samples in this layer were mostly described as silty sand. This layer contained traces of organic soil and roots.

Fill – A layer of fill was encountered beneath the forest mat/topsoil, subsoil, buried organic soil, or asphalt in borings B-1 to B-5 and in test pits TP-1 to TP-3. The fill layer extended to the termination depths of 8.1 to 9.5 feet beneath the ground surface at test pits TP-1 to TP-3 and to depths ranging between 6 and 16.7 feet below ground surface in borings B-1 to B-5. The fill was mostly described as silty sand and less frequently as poorly graded sand or well graded sand. Three samples were described as silty gravel. The fines content encountered in the fill layer ranged between 0 and 35 percent. The gravel content encountered in the fill layer was up to approximately 35 percent. The sand content in the gravel samples ranges up to 35 percent. The fill contained boulders and cobbles up to 1.1 feet in size and traces of organic fines, roots, and brick.

The SPT N-values in the fill ranged between 7 and 40 blows per foot (bpf), with most values lower than 20 bpf, indicating loose to medium dense material. The high SPT N-values may be caused by obstructions in the fill. And may not represent the true density of the fill.



**Geotechnical Report
Proposed Education Center and Event Pavilion
Roger Williams Park Zoo
Providence, Rhode Island
LGCI Project No. 1911**

Buried Organic Soil – A layer of buried organic soil was encountered beneath the fill in boring B-4 and extended to a depth of 18 feet beneath the ground surface. The peat was described as fibrous.

Sand – A layer of sand was encountered below the fill or buried organic soil in borings B-1 to B-5 and extended to the termination depths of the borings. The sand was mostly described as silty sand or poorly graded sand and less frequently as well graded sand. One sample was described as well graded gravel. The fines content in the sand ranged between 0 and 25 percent. The gravel content in the sand ranged up to approximately 35 percent. The fines content in the gravel ranged between 0 and 5 percent. The sand content in the gravel ranged between 30 and 35 percent. This layer contained traces of angular stone fragments and roots.

The SPT N-values in this layer ranged between 7 bpf and 41 bpf, with most values between 11 and 20 bpf, indicating mostly medium dense sand.

Proposed Event Pavilion (Borings B-6 and B-7 and Test Pit TP-4)

Asphalt – A layer of asphalt was encountered at the ground surface in boring B-6. The asphalt was 0.2-foot thick.

Topsoil – A layer of surficial organic topsoil was encountered at the ground surface in boring B-7. This layer extended to a depth of 2 feet beneath ground surface. The topsoil contained traces of bricks.

Fill – A layer of fill was encountered at the ground surface in test pit TP-4 and beneath the topsoil, or asphalt in borings B-6 to B-7. The fill extended to depths ranging between 4.9 and 15 feet below ground surface. The fill was described as silty sand. The fines content in the fill ranged between 15 and 35 percent. The gravel content in the fill ranged up to approximately 25 percent. The fill contained cobbles and boulders, and traces of organic soil and roots.

The SPT N-values in the fill ranged between 3 and 11 blows per foot (bpf), with most values ranging between 3 and 7 bpf, indicating very loose to loose material.

Peat – A layer of peat was encountered beneath the fill in borings B-6 and B-7 and extended to depths ranging between 19 and 20 feet below ground surface. The peat was described as fibrous. One sample was described as silty sand with the fines ranging between 20 and 25 percent.

Silt – A layer of silt was encountered below the peat or fill in test pit TP-4 and in boring B-6 and extended to the termination depth of TP-4 and to a depth of 24 feet beneath the ground surface in boring B-6. The silt was described as non-plastic to slightly plastic with the sand content ranging between 15 and 20 percent. The silt contained traces of organic soil and roots.

The SPT N-value in this layer was 2 bpf, indicating a soft material.



**Geotechnical Report
Proposed Education Center and Event Pavilion
Roger Williams Park Zoo
Providence, Rhode Island
LGCI Project No. 1911**

Sand – A layer of sand was encountered below the silt or peat in borings B-6 and B-7 and extended to the boring termination depths. The sand was mostly described as poorly graded sand and less frequently as silty sand. Two samples were described as well graded sand and silty gravel (one each). The fines content in the sand ranged between 0 and 25 percent. The gravel content in the sand ranged up to approximately 25 percent. The fines content in the gravel ranged between 15 and 20 percent and the sand content in the gravel ranged between 30 and 35 percent..

The SPT N-values in this layer ranged between 2 and 20 bpf, indicating very loose to medium dense sand.

2.5 Groundwater

Groundwater was measured in the borings and in test pit TP-4 at depths ranging between 4.5 and 15 feet below the ground surface.

The groundwater levels were measured during or shortly after completion of our explorations or were estimated based on sample moisture, as noted in the logs. In addition, the drilling technique introduced water in the boreholes during drilling. Therefore, the water levels noted may not represent the actual groundwater levels, as additional time may be required for the groundwater levels to stabilize. The groundwater level presented in this report only represents the conditions encountered at the time and location of the explorations. Variations in groundwater at the site due to seasonal fluctuations should be anticipated.

2.6 Laboratory Test Data

LGCI submitted two (2) soil samples collected from the borings for grain-size analyses. The results of the grain-size analyses are provided in the test data sheets included in Appendix D and are summarized in the table below.

Grain-Size Analysis Test Results

Boring No.	Sample No.	Stratum	Sample depth (ft.)	Percent Gravel	Percent Sand	Percent Fines
B-3	S2	Fill	2 – 4	5	86.6	8.4
B-5	S3	Fill	4 – 6	26.9	65	8.1



3. EVALUATION AND RECOMMENDATIONS

3.1 General

Based on our understanding of the proposed construction, our observation of the test pits and borings, and the results of our laboratory testing, there are a few issues that we would like to highlight for consideration and discussion.

3.1.1 Existing Fill and Surficial and Buried Organic Soil

Existing very loose to medium dense fill was encountered in the test pits and borings. The fill was observed to extend to depths of up to 16.7 feet in the test pits and borings performed within the proposed Education Center, and up to depths of 15 feet in the borings and test pit performed within or near the proposed Event Pavilion. Existing fill that was not placed with strict moisture, density, and gradation control presents the risk of unpredictable settlements that may result in the poor performance of floor slabs and foundations. Buried organic soil was also observed in one boring advanced within the proposed Education Center and both borings advanced within the proposed Event Pavilion. The buried organic soil extended to depths of 18 and 20 feet beneath the ground surface, respectively. Organic soil left in place underneath the proposed foundations and slabs may result in larger than acceptable settlements. Due to these risks, the existing fill and buried organic soil are not suitable to support the proposed buildings.

3.1.2 Foundation Recommendations

Given the depth to the bottom of the unsuitable material, the presence of groundwater, and the proximity to existing walkways, exhibits, and buildings, the option of removing and replacing the unsuitable materials is not feasible. We recommend supporting the proposed building on shallow foundations bearing on ground improved with grouted aggregate piers as described below.

3.2 Ground Improvements

3.2.1 General

We have considered ground improvements using aggregate piers (APs) and rigid inclusions. However, based on our understanding of the project requirements and our experience, we anticipate the ground improvement using APs extending into the sand layer beneath the existing fill, and buried organic soil will be more suitable at this site than rigid inclusions, as APs densify the soil within which they are installed.



 NOTE: The Contractor is to proceed using the aggregate pier/load transfer platform recommendation.

3.2.2 Aggregate Piers

The APs should be designed to meet the settlement tolerances of 1 inch total settlement, and ½ inch differential settlement over a distance of 25 feet.

Due to the presence of organic soil, the aggregate piers should be grouted to reduce the potential for bulging of the piers in the organic soil. The installation of grouted-APs is similar to conventional AP construction except that grout is introduced into the stone backfill during placement and compaction.

APs are typically relatively short, stiff elements of compacted aggregate which improve the existing fill. These elements are typically installed by augering holes ranging from 20 inches to 36 inches in diameter. Aggregate (crushed stone or recycled concrete) is then introduced into the hole and is generally compacted in one-foot lifts by repeated penetrations with the vibrator, which can be mounted to a crane or tracked carrier. The vibratory or ramming energy densifies the aggregate in the element; thus, producing high modulus aggregate piers. The installation of APs also densifies the surrounding soil depending on the type of soil. These high modulus elements reinforce the treatment zone and increase the composite friction angle and stiffness of the reinforced soil mass.

The design of APs should be verified with a modulus load test.

While the AP installation generates far fewer spoils than complete removal and replacement, some spoils are created during the installation process. Where it is not desirable to generate spoils during the improvement process, vertical displacement APs could be used. These are installed by driving a mandrel and hammer to the design depth, feeding the backfill material through the hollow mandrel, and compacting the backfill in one-foot lifts using the hammer; thus, generating no spoils. Vertical displacement APs are installed with diameters ranging between 12 and 16 inches.

The ground improvement technologies are patented, and the design is performed by the specialty contractors. We recommend that the project plans and specifications for ground improvement be performance-based, allowing a variety of ground improvement contractors the opportunity to bid the work. Specifications should indicate the required allowable bearing pressure for footings and slabs, and the allowable total and differential settlements for the structure. In addition, we recommend that the specifications require that the supporting design calculations be available for review by the design team. Ground improvement contractors should also be provided with grading plans and subsurface information associated with the proposed structure for use in preparing their bids.

At sites with a high groundwater table, APs are installed with a casing that is removed as the AP hole is backfilled.



The final number, layout, size, and depth of the ground improvement should be provided by a professional engineer registered in Rhode Island who specializes in the design of this type of ground improvement and engaged by the specialty contractor. A modulus test of each type of installed piers will be required before the start of production. LGCI should be engaged to review the design and to provide field monitoring.

3.2.3 Site Preparation for Aggregate Piers

While LGCI did not observe obstructions in the fill in our borings, based on the filling history of the site, the existing fill may include obstructions that need to be pre-trenched. The work of the specialty contractor installing the APs should be coordinated with that of the site contractor who should perform pre-trenching for possible boulders, abandoned foundations, or other obstructions before the installation of the APs.

3.2.4 Protection of APs

The APs installed beneath the proposed slab and interior footings will extend to higher elevations than those installed for the perimeter footings. The contractor should exercise care while excavating for exterior footings so as not to disturb the APs installed for the slab and interior footings. Also, the aggregate piers installed for the second floor of the proposed Education Center should be protected during construction of the retaining wall separating the two floors of this building.

3.3 Footing Design

- For footings bearing on AP-improved ground, we recommended using a net allowable bearing pressure of 3,000 pound per square foot (psf).
- All foundations should be designed in accordance with *The Rhode Island State Building Code, Eleventh Edition* (RISBC11th Edition).
- Exterior footings and footings in unheated areas should be placed at minimum depths of 3.4 feet below final exterior grades to provide adequate frost cover protection. Interior footings in heated areas of the proposed building may be designed and constructed at a minimum depth of 2 feet below finished floor grades.
- We recommend that wall footings have a minimum width of 2 feet, and that column footings have a minimum width of 3 feet. For foundations with a least lateral dimension smaller than 3 feet, the allowable bearing pressure should be reduced to 1/3 of the recommended allowable bearing pressure times the least dimension in feet.



**Geotechnical Report
Proposed Education Center and Event Pavilion
Roger Williams Park Zoo
Providence, Rhode Island
LGCI Project No. 1911**

- Wall footings should be designed and constructed with continuous, longitudinal steel reinforcement for greater bending strength to span across small areas of loose or soft soils that may go undetected during construction.
- A representative of LGCI should observe installation of the ground improvement and the footing subgrade to verify that the subgrade has been prepared in accordance with our recommendations.

3.4 Settlement Under Static Load

For footings constructed in accordance with the recommendations in this report, we estimate that the total settlement under static loads will be about 1 inch, and that the differential settlement will range up to about $\frac{3}{4}$ inch over a distance of 25 feet under static loading. Total and differential settlements of these magnitudes are usually considered tolerable for the anticipated construction. However, the tolerance of the proposed structures to the predicted total and differential settlements should be assessed by the Structural Engineer.

3.5 Concrete Slab Considerations

We recommend constructing the proposed slabs as slabs-on-grade constructed on a minimum of 9 inches of Structural Fill placed on the AP-improved ground. Preparation of the subgrade should conform to the recommendations presented in Section 4.1.

To reduce the potential for dampness getting into the floor slabs, the Project Architect may consider placing a vapor barrier beneath the floor slabs.

Please note that cracking of slabs-on-grade can occur as a result of heaving or compression of the underlying soil, but also as a result of concrete curing stresses. To reduce the potential for cracking, the precautions listed below should be closely followed for construction of all slabs-on-grade:

- Construction joints should be provided between the floor slab and the walls and columns in accordance with the American Concrete Institute (ACI) requirements, or other applicable code.
- Backfill in interior and exterior utility trenches should be properly compacted.
- In order for the movement of exterior slabs not to be transmitted to the building foundation or superstructure, exterior slabs should be isolated from the building superstructure.



3.6 Under-slab Drains

Based on the groundwater levels observed in the test pits and borings, we believe that an under-slab drainage system is not needed for the proposed Event Pavilion and the second floor of the proposed Education Center. However, the groundwater levels observed at the end of drilling in borings B-2, B-4, and B-5 were at or slightly higher than the proposed FFE of the first floor of the proposed Education Center. Accordingly, we recommend an under-slab drainage system beneath the first floor of the proposed Education Center.

NOTE: The under-slab drains and perimeter wall drains are not required.

The under-slab drainage system should consist of 1) a minimum of 9 inches of ¾-inch crushed stone placed below the slab, and 2) 6-inch-diameter slotted PVC pipes installed with their inverts at least 18 inches below the bottom of the slab. The pipes should be installed in trenches placed at 15 to 20 apart. The trenches should be at least 18 inches wide and 12 inches deep (below the bottom of the 9 inches of crushed stone) to allow placing crushed stone around the PVC pipe. The slotted PVC pipes should connect to a 6-inch solid PVC header pipe that collects and channels the collected water out of the building.

A non-woven geotextile fabric should be installed between the crushed stone and the underlying soil for separation. The slots on the PVC pipes should be placed facing downward to allow for entry of water at the bottom of the pipe. Clean-outs should be included at the end of the perforated pipes.

If possible, the water from the under-slab drainage system should be channeled to flow by gravity to a discharge area or to the City storm drainage system. If gravity drainage is not possible, groundwater from the under-slab drainage system should be collected in a sump pump pit and discharged using a sump pump. If the water from the drainage system is channeled to the City storm drainage system, the owner should apply for a discharge permit and should perform analytical tests as required by the permits.

3.7 Retaining Wall

3.7.1 Lateral Earth Pressures

We recommend using the following lateral earth pressures for the design of retaining walls:

Coefficient of Active Earth Pressure, K_A :	0.31
Coefficient of At-Rest Earth Pressure, K_o :	0.5
Coefficient of Passive Earth Pressure, K_p :	3.3
Total Unit Weight, γ :	125 pounds per cubic foot

Note: The values in the table are based on a friction angle for the backfill of 32 degrees and neglecting friction between the backfill and the wall. The design active and passive coefficients are based on horizontal surfaces (non-sloping backfill) on both the active and passive sides, and a vertical wall face.



**Geotechnical Report
Proposed Education Center and Event Pavilion
Roger Williams Park Zoo
Providence, Rhode Island
LGCI Project No. 1911**

- Exterior walls of below ground spaces and the wall separating the two floors of the proposed Education Center should be designed using the “at-rest” pressure coefficient.
- Site retaining walls should be designed using the active earth pressure coefficient described above.
- Passive earth pressures should only be used at the toe of the wall where special measures or provisions are taken to prevent disturbance or future removal of the soil on the passive side of the wall, or in areas where the wall design includes a key.
- Where a permanent vertical uniform load will be applied on the active side immediately adjacent to the wall, a horizontal surcharge load equal to half of the uniform vertical load should be applied over the height of the wall. At a minimum, a temporary construction surcharge of 100 psf should be applied uniformly over the height of the wall.
- We recommend using an ultimate friction factor of 0.45 between the natural soil and the bottom of the retaining wall. Retaining walls should be designed for minimum factors of safety of 1.5 for sliding and 2.0 for overturning.

3.7.2 Wall Drains

- We recommend that free-draining material be placed within 3 feet of the exterior of walls of below ground spaces of buildings, if any, and behind site retaining walls.
- To reduce the potential for dampness in below ground building spaces, if any, proposed below ground walls should be damp-proofed.
- We recommend that drains be provided behind the exterior of walls of below ground spaces, if any, behind the wall separating the two floors, and behind site retaining walls. The drains should consist of 6-inch perforated PVC pipes installed with the slots facing down. Perimeter drains should be installed at the bottom of the wall in 18 inches of crushed stone wrapped in a geotextile for separation and filtration.

Groundwater collected by the wall drains could be discharged in a lower area if gravity flow is possible. Alternatively, it should be discharged into the street drains. A permit would be required for discharge into street drains. For site retaining walls, the water collected from the drains could be discharged through weep holes. If wetness on the face of the wall is not desirable, the wall drains should be connected to the street drains.



3.8 Seismic Design

3.8.1 Seismic Design Parameters

In accordance with the 2012 International Building Code as adopted by Rhode Island and Table 1608.1, the seismic criteria are as follows:

- Site Class (IBC Table 1613.5.2): E
- Spectral Response Acceleration at short period (S_s) (RI Table 1608.1): 0.176 g
- Spectral Response Acceleration at 1 sec. (S_1) (RI Table 1608.1): 0.062 g
- Site Coefficient F_a - IBC Table 1613.3.3(1): 2.5
- Site Coefficient F_v - IBC Table 1613.3.3(2): 3.5
- Adjusted spectral response S_{ms} : 0.440 g
- Adjusted spectral responses S_{m1} : 0.217 g

3.8.2 Liquefaction Potential

LGCI had previously performed an evaluation for the liquefaction potential of the site of the veterinary hospital in the event of a seismic event. Our evaluation had indicated that the sand deposit below the veterinary hospital is considered susceptible to liquefaction between approximately 20 and 30 feet below the ground surface. LGCI did not perform a liquefaction analysis for this project. However, based on boring B-204 we believe that the same conclusion previously arrived at for the existing veterinary hospital is applicable for the proposed Education Center and Event Pavilion, i.e., the local zones of soil between the depths of 20 and 30 feet are susceptible to liquefaction during a seismic event.

3.8.3 Earthquake Induced Settlement

We anticipate that the proposed Education Center and Event Pavilion will experience settlement larger than one inch during a seismic event. We believe that such settlements could cause significant cracking and damage to the buildings. If such settlements are not desired during a seismic event, ground improvements techniques should be carried out to greater depths. The owner should perform a cost benefit analysis that takes into consideration the mitigation of the risk during a seismic event and the cost associated with ground improvement to great depths.

3.8.4 Seismic Ties for Footings

Depending on the Seismic Design Category of the proposed buildings, seismic ties may be required between footings in accordance with RISBC 11th Edition, Section 1810.3.13. The owner may consider providing such ties anyway to reduce the potential for collapse during a seismic event.



3.9 Underground Utilities

To reduce the potential for post-installation settlement, the owner may consider installing the utility connections within a corridor improved using APs. Alternatively, the utilities should be installed in sleeves at the entrance of the building to allow for some movement within the sleeves without risk of rupture or damage to the utilities.

Cobbles at the bottom of utility trenches should be removed to at least 12 inches below the pipe invert and the resulting excavation should be backfilled with suitable backfill. Utilities should be placed on suitable bedding material in accordance with the manufacturer's recommendations. "Cushion" material should be placed, by hand, above the utility pipe in maximum 6-inch lifts. The lift should be compacted by hand to avoid damage to the utility. Where the bedding/cushion material consists of crushed stone, it should be wrapped in a geotextile fabric.

Compaction of fill in utility trenches should be in accordance with our recommendations in Section 4.3. To reduce the potential for damage to utilities, placement and compaction of fill immediately above the utilities should be performed in accordance with the manufacturer's recommendations.

3.10 Sidewalks

Sidewalks should be placed on a minimum of 12 inches of Structural Fill with less than 5 percent fines. To reduce the potential for heave caused by surface water penetrating under the sidewalk, the joints between sidewalk concrete sections should be sealed with a waterproof compound. The sidewalks should be sloped away from the building or other vertical surfaces to promote flow of water. To the extent possible, roof leaders should not discharge directly onto sidewalk surfaces.



4. CONSTRUCTION CONSIDERATIONS

NOTE: All items noted in this Section 4 are to be included in this construction.

4.1 Subgrade Preparation

- Surficial topsoil/subsoil, abandoned utilities, and other below-ground structures should be entirely removed from within the footprint of the proposed buildings before the start of foundation work. The removal should extend a minimum of 5 feet beyond the limits of the proposed improvements on all sides.
- Tree stumps, root balls, and roots larger than ½ inch in diameter should be removed and the cavities filled with suitable material and compacted per Section 4.3 of this report. Care should be exercised during stripping to reduce the potential for disturbance of the subgrade.
- A load transfer platform (LTP) layer should be installed on top of AP-improved ground per the requirements of the designer of the APs.
- Surficial topsoil should be entirely removed from within the paved areas. The subsoil and existing fill should also be removed to a depth such that the final pavement cross section will consist of asphalt, over the subbase layer, over a minimum of 12 inches of Ordinary Fill. Before placing the Ordinary Fill, the exposed subgrade should be proof-rolled using a loaded rubber tire truck or with a vibratory roller compactor imparting a minimum effort of 40 kips. Where ruts are formed, or soft zones are encountered, the rutted soil and soft zones should be removed and replaced with Ordinary Fill.
- The buried organic soil, where encountered, should be removed within 3 feet of the bottom of the proposed paved areas. We recommend that the site contractor perform test pits at the start of the earthwork operations to delineate the limits of the buried organic soil and assess its depth. LGCI should observe the test pits.
- The base of the footing excavations in granular soil should be compacted with a dynamic vibratory compactor weighing at least 200 pounds and imparting a minimum of 4 kips of force to the subgrade, before placing the required 6 inches of Structural Fill.
- Fill placed within the footprint of the proposed building should meet the gradation and compaction requirements of Structural Fill shown in Section 4.3.1.
- Fill placed within the proposed paved areas should meet the gradation and compaction requirements of Ordinary Fill shown in Section 4.3.2.
- To reduce the potential of increasing lateral pressures on the retaining walls, fill placed within 3 feet of retaining walls should be compacted using a small plate compactor imparting a maximum dynamic effort of 4 kips. The fill within 3 feet of the walls should be placed in maximum 8-inch loose lifts.



**Geotechnical Report
Proposed Education Center and Event Pavilion
Roger Williams Park Zoo
Providence, Rhode Island
LGCI Project No. 1911**

- Loose or soft soils identified during the compaction of the subgrade of footings, floor slabs, and paved areas should be excavated to a suitable bearing stratum as determined by the representative of LGCI. Grades should be restored by backfilling with Structural Fill or crushed stone within the footprint of buildings and with Ordinary Fill within the paved areas.
- When crushed stone is required in the drawings or it is used for the convenience of the contractor, it should be wrapped in a geotextile fabric for separation except where introduction of the geotextile promotes sliding. A geotextile should not be placed between the bottoms of the footings and crushed stone.
- An LGCI representative should observe the exposed subgrades prior to fill and concrete placement to verify that the exposed bearing materials are suitable for the design soil bearing pressure. If soft or loose pockets are encountered in the footing excavations, the soft or loose materials should be removed, and the bottom of the footing should be placed at a lower elevation on firm soil, or the resulting excavation should be backfilled with Structural Fill, or crushed stone wrapped in a filter fabric.

4.2 Subgrade Protection

The existing fill is frost susceptible. If construction takes place during freezing weather, special measures should be taken to prevent the subgrade from freezing. Such measures should include the use of heat blankets or excavating the final six inches of soil just before pouring concrete. Footings should be backfilled as soon as possible after footing construction. Soil used as backfill should be free of frozen material, as should the ground on which it is placed. Filling operations should be halted during freezing weather.

Materials with high fines contents are typically difficult to handle when wet as they are sensitive to moisture content variations. Subgrade support capacities may deteriorate when such soils become wet and/or disturbed. The contractor should keep exposed subgrades properly drained and free of ponded water. Subgrades should be protected from machine and foot traffic to reduce disturbance.

4.3 Fill Materials

Structural Fill and Ordinary Fill should consist of inert, hard, durable sand and gravel, free from organic matter, clay, surface coatings and deleterious materials, and should conform to the gradation requirements shown below.



4.3.1 Structural Fill

The Structural Fill should have a plasticity index of less than 6 and should meet the gradation requirements shown below. Structural Fill should be compacted in maximum 9-inch loose lifts to at least 95 percent of the Modified Proctor maximum dry density (ASTM D1557), with moisture contents within ± 2 percentage points of optimum moisture content.

Sieve Size Percent	Passing by Weight
3 inches	100
1 ½ inch	80-100
½ inch	50-100
No. 4	30-85
No. 20	15-60
No. 60	5-35
No. 200*	0-10

* 0 – 5 for top 12 inches under sidewalks and exterior slabs

4.3.2 Ordinary Fill

Ordinary Fill should have a plasticity index of less than 6 and should meet the gradation requirements shown below. Ordinary Fill should be compacted in maximum 9-inch loose lifts to at least 95 percent of the Modified Proctor maximum dry density (ASTM D1557), with moisture contents within ± 2 percentage points of optimum moisture content.

Sieve Size Percent	Passing by Weight
6 inches	100
1 inch	50-100
No. 4	20-100
No. 20	10-70
No. 60	5-45
No. 200	0-20

4.4 Reuse of Onsite Materials

Based on our field observations and the results of the grain-size analyses, the existing fill does not meet the gradation requirements for Structural Fill. We anticipate that some of the existing fill may be suitable for reuse as Ordinary Fill.

The contractor should avoid mixing the existing soils with suitable imported material. Should reusable materials be encountered during excavation, they should be excavated and stockpiled separately for compliance testing.



**Geotechnical Report
Proposed Education Center and Event Pavilion
Roger Williams Park Zoo
Providence, Rhode Island
LGCI Project No. 1911**

Soils with 20 percent or greater fines content are generally very sensitive to moisture content variations and are susceptible to frost. Such soils are very difficult to compact at moisture contents that are much higher or much lower than the optimum moisture content determined from the laboratory compaction test. Therefore, strict moisture control should be implemented during compaction of onsite soils with fines contents of 20 percent or greater. The contractor should be prepared to remove and replace such soils if pumping occurs.

All materials to be used as fill should first be tested for compliance with the applicable gradation specifications.

4.5 Groundwater Control Procedures

Based on the groundwater levels encountered in our explorations, we do not anticipate that major groundwater control procedures will be needed during excavation for proposed footings. We anticipate that filtered sump pumps installed in a series of sump pits located at least three feet below the bottom of the proposed excavations may be sufficient to handle surface runoff that may enter the excavations during wet weather. The site contractor should be prepared to use multiple sumps when removing the deep unsuitable materials.

The contractor should be permitted to employ whatever commonly accepted means and practices are necessary to maintain the groundwater level below the bottom of the excavations, and to maintain a dry excavation during wet weather. Groundwater levels should be maintained at a minimum of 1-foot below the bottom of excavations during construction. Placement of reinforcing steel or concrete in standing water should not be permitted.

To reduce the potential for sinkholes developing over sump pump pits after the sump pumps are removed, the crushed stone placed in the sump pump pits should be wrapped in a geotextile fabric. Alternatively, the crushed stone should be entirely removed after the sump pump is no longer in use and the sump pump pit should be restored with suitable backfill.

4.6 Temporary Excavations

All excavations to receive human traffic should be constructed in accordance with the OSHA guidelines.

The site soils should generally be considered Type “C” and should have a maximum allowable slope of 1.5 Horizontal to 1 Vertical (1.5H:1V) for excavations less than 20 feet deep. Deeper excavations, if needed, should have shoring designed by a professional engineer.

The contractor is solely responsible for designing and constructing stable, temporary excavations and should shore, slope, or bench the sides of the excavations as required to maintain stability of the excavation sides and bottom and to protect existing structures.



5. RECOMMENDATIONS FOR FUTURE WORK

As part of our current scope, LGCI will prepare Earth Moving and Aggregate Pier specifications.

We recommend engaging LGCI to perform the following services:

- Review the geotechnical aspect of foundation drawings.
- Review the geotechnical aspects of contractor submittals and requests for information (RFIs).
- Provide a field representative to observe the installation of APs.
- Provide a field representative during construction to observe the subgrade of foundations and slabs.



6. REPORT LIMITATIONS

Our analysis and recommendations are based on project information provided to us at the time of this report. If changes to the type, size, and location of the proposed structures or to the site grading are made, the recommendations contained in this report shall not be considered valid unless the changes are reviewed, and the conclusions and recommendations modified in writing by LGCI. LGCI cannot accept responsibility for designs based on our recommendations unless we are engaged to review the final plans and specifications to determine whether any changes in the project affect the validity of our recommendations and whether our recommendations have been properly implemented in the design.

It is not part of our scope to perform a more detailed site history; therefore, we have not explored for or researched the locations of buried utilities or other structures in the area of the proposed construction. Our scope did not include environmental services or services related to moisture, mold, or other biological contaminants in or around the site.

The recommendations in this report are based in part on the data obtained from the subsurface explorations. The nature and extent of variations between explorations may not become evident until construction. If variations from anticipated conditions are encountered, it may be necessary to revise the recommendations in this report. We cannot accept responsibility for designs based on recommendations in this report unless we are engaged to 1) make site visits during construction to check that the subsurface conditions exposed during construction are in general conformance with our design assumptions and 2) ascertain that, in general, the work is being performed in compliance with the contract documents.

Our report has been prepared in accordance with generally accepted engineering practices and in accordance with the terms and conditions set forth in our agreement. No other warranty, expressed or implied, is made. This report has been prepared for the exclusive use of the Saccoccio & Associates, Inc. for the specific application to the proposed Education Center and Event Pavilion at the Roger Williams Park Zoo in Providence, Rhode Island as conceived at this time.



**Geotechnical Report
Proposed Education Center and Event Pavilion
Roger Williams Park Zoo
Providence, Rhode Island
LGCI Project No. 1911**

7. REFERENCES

In addition to the references included in the text of the report, we used the following references:

Rhode Island State Building Code (2007), State of Rhode Island and Providence Plantations, 11th Edition.

United States Geologic Survey (1956), “Surficial Geology of the Providence quadrangle, Rhode Island,” by J. H. Smith, Geologic Quadrangle Map GQ-84.

USGS Providence, RI Topographic Map from www.mapserver.mytopo.com.



**Table 1 - Summary of LGCI Test Pits
Proposed Education Center and Event Pavilion
Providence, Rhode Island
LGCI Project No. 1911**

Test Pit No.	Ground Surface Elevation (ft.) ¹	Groundwater ² Depth / El. (ft.)	Bottom of Topsoil / Subsoil / Forest Mat Depth / El. (ft.)	Bottom of Fill Depth / El. (ft.)	Depth to Bottom of Sand / Silt Depth / El.(ft.)	Bottom of Test Pit Depth / El. (ft.)
TP-1	40.0	- / -	0.8 / 39.2	- ³ / -	- / -	8.5 / 31.5
TP-2	40.0	- / -	0.7 / 39.3	- ³ / -	- / -	8.1 / 31.9
TP-3	42.0	- / -	0.9 / 41.1	- ³ / -	- / -	9.5 / 32.5
TP-4	30.5	7.1 / 23.4	- / -	6.5 / 24.0	- ⁴ / -	7.5 / 23.0

1. The ground surface elevation was interpolated to the nearest foot from drawing C-1.4 titled: "Grading & Drainage Plan, Education Center & Pavilion, Roger William Park Zoo," prepared by Garofalo & Associates, Inc. dated June 13, 2019 and e-mailed to LGCI by Garofalo & Associates, Inc. on September 19, 2019.
2. Groundwater was measured during excavation, at the end of excavation, or based on sample moisture, as indicated in the test pit logs.
3. Test pit terminated in fill.
4. Test pit terminated in silt.
5. "-" means layer was not encountered.

**Table 2 - Summary of LGCI Borings
Proposed Education Center and Event Pavilion
Providence, Rhode Island
LGCI Project No. 1911**

Boring No.	Ground Surface Elevation (ft.) ¹	Groundwater ² Depth / El. (ft.)	Bottom of Asphalt / Topsoil / Forest Mat ³ Depth / El. (ft.)	Bottom of Fill Depth / El. (ft.)	Bottom of Buried Organic Soil Depth / El. (ft.)	Bottom of Sand Depth / El. (ft.)	Bottom of Boring Depth / El. (ft.)
2009 Borings							
B-204	32.0	4.0 / 28.0	- / -	4.5 / 27.5	7.0 / 25.0	⁻⁵ / -	41.0 / -9.0
B-205	32.0	4.7 / 27.3	- / -	7.2 / 24.8	9.5 / 22.5	⁻⁵ / -	17.0 / 15.0
2019 Borings							
B-1	37.0	6.3 / 30.7	0.2 / 36.8	16.5 / 20.5	- / -	⁻⁵ / -	22.0 / 15.0
B-2	40.0	6.0 / 34.0	0.5 / 39.5	6.0 / 34.0	- / -	⁻⁵ / -	30.0 / 10.0
B-3	42.0	15.0 / 27.0	0.5 / 41.5	7.0 / 35.0	- / -	⁻⁵ / -	22.0 / 20.0
B-4	45.0	6.1 / 38.9	4.4 / 40.6	16.7 / 28.3	18.0 / 27.0	⁻⁵ / -	34.0 / 11.0
B-5	44.5	6.5 / 38.0	0.2 / 44.3	16.0 / 28.5	- / -	⁻⁵ / -	31.0 / 13.5
B-6	33.0	4.5 / 28.5	0.2 / 32.8	4.9 / 28.1	19.0 / 14.0	^{-4.5} / -	52.0 / -19.0
B-7	33.0	5.4 / 27.6	2.0 / 31.0	15.0 / 18.0	20.0 / 13.0	⁻⁵ / -	32.0 / 1.0

1. The ground surface elevation was interpolated to the nearest foot from drawing C-1.4 titled: "Grading & Drainage Plan, Education Center & Pavilion, Roger William Park Zoo," prepared by Garofalo & Associates, Inc. dated June, 13, 2019 and emailed to LGCI by Garofalo & Associates, Inc. on September 19, 2019.
2. Groundwater was measured during drilling, at the end of drilling, or based on sample moisture, as indicated in the boring logs.
3. Top 0.5' and 0.2' of boring B-3 and B-6, respectively were in asphalt.
4. At boring B-6 silt was encountered beneath the fill and extended to a depth of 24'.
5. Boring terminated in sand.
6. "-" means layer was not encountered.



Figure based on USGS topographic map of Providence, RI obtained from www.mytopo.com/maps

Client: Saccoccio & Associates, Inc.	Project: Proposed Education Center and Event Pavilion	Figure 1 – Site Location Map	
 LGCI Lahlaf Geotechnical Consulting, Inc.	Project Location: Providence, RI	LGCI Project No.: 1911	Date: Dec. 2019

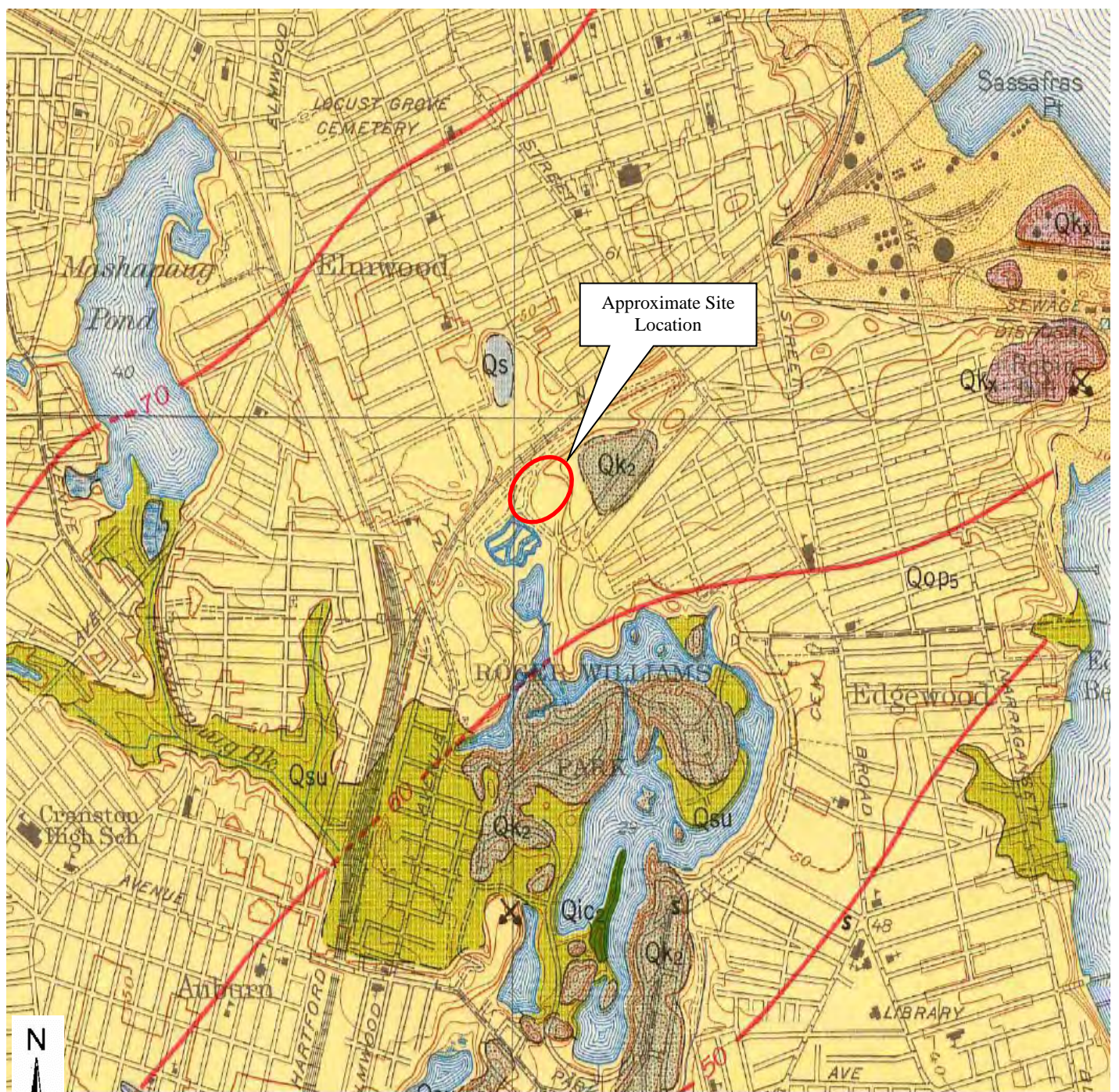

Qop5 **Outwash plains**
Sorted sand and local deposits of coarse gravel.

Figure based on map titled: "Geologic Map of the Providence Quadrangle, Rhode Island, Surficial Geology," prepared by Smith, J.H. for U.S. Geological, Surficial Geology Providence Quadrangle Rhode Island GQ 84.

Client:
Saccoccio & Associates, Inc.

Project:
Proposed Education Center and Event Pavilion

Figure 2 – Surficial Geologic Map



Project Location:
Providence, RI

LGCI Project No.:
1911

Date:
Dec. 2019

MASSACHUSETTS STATE PLANNING COORDINATE SYSTEM
 NAD 83

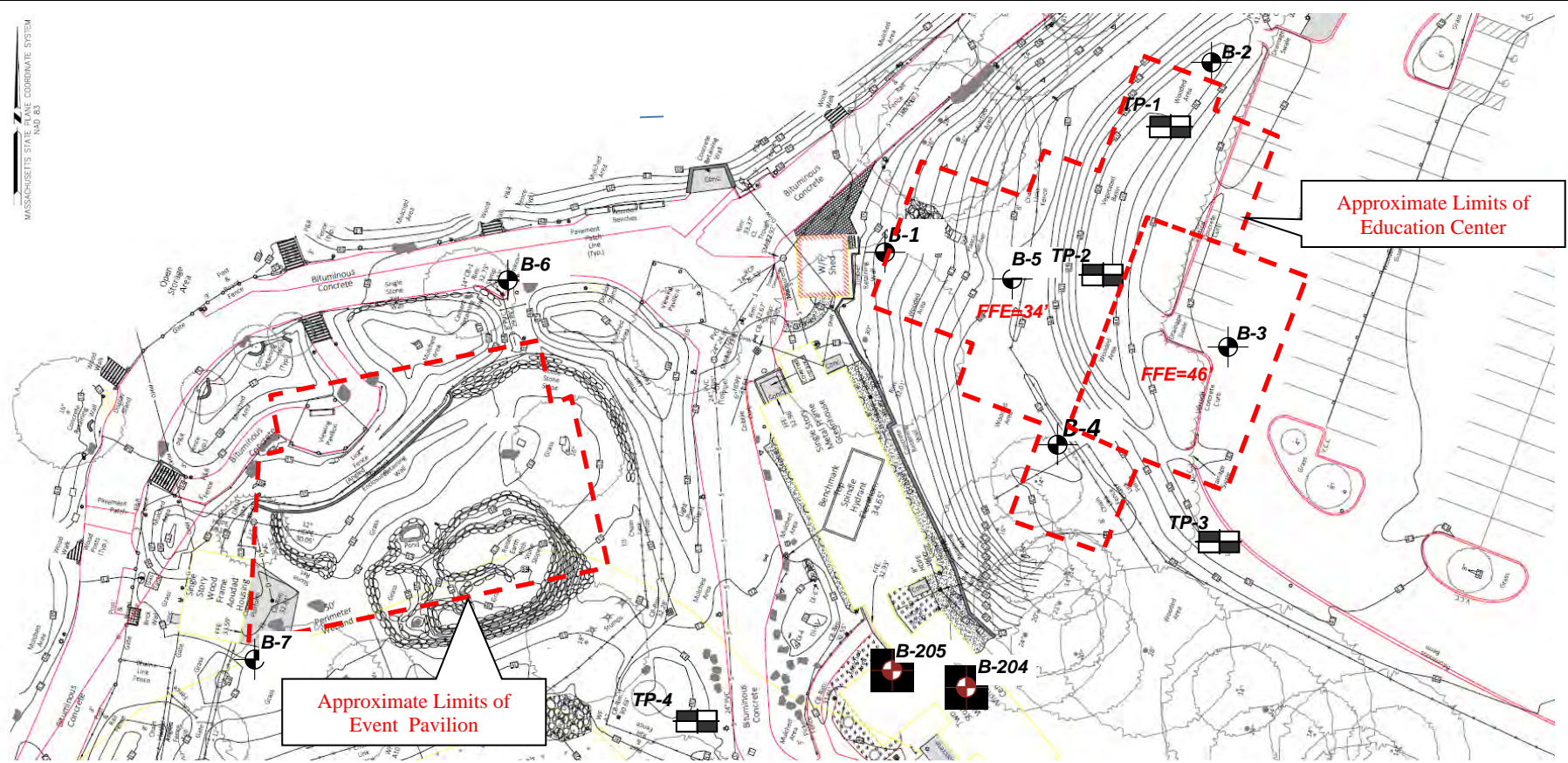

Approximate Limits of Education Center

Approximate Limits of Event Pavilion

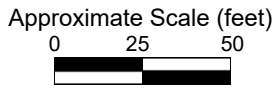

Legend

Approximate location of borings advanced by Hoffman Environmental Services, Inc. of North Kingstown, RI on August 6 and 12, 2019 and observed by LGCI.

Approximate location of test pits excavated by Hoffman Environmental Services, Inc. of North Kingstown, RI on August 7, 2019 and observed by LGCI.

Approximate location of borings advanced by Subsurface Drilling and Remediation Co. of Tiverton, RI on June 29, 2009 and observed by LGCI.

Note

- Figure based on a progress drawing titled: "Proposed C1.0," prepared by Saccoccio & Associates Architects, Inc. and e-mailed to LGCI by Saccoccio & Associates Architects, Inc. on July 19, 2019.

Client: Saccoccio & Associates, Inc.	Project: Proposed Education Center and Event Pavilion	Figure 3 – Test Pit and Boring Location Plan	
 LGCI Lahlaf Geotechnical Consulting, Inc.	Project Location: Providence, RI	LGCI Project No.: 1911	Date: Dec. 2019

THIS PAGE INTENTIONALLY LEFT BLANK

APPENDIX A - Logs of LGCI's Previous Boring

Project: Prop. Veterinary Hospital and Children's Zoo, Roger Williams Park Zoo, Providence, RI	
Client: Yoder + Tidwell, Ltd.	LGCI Project No.: 0917
Drilling Subcontractor: Subsurface Drilling	Date Started: 06/29/09
Drilling Foreman: Brad Haase	Date Completed: 06/29/09
LGCI Engineer: Jennifer MacGregor	Location: SE of children's zoo house
Ground Surface El: 32 interpolated from site plan	Total Depth: 41 feet
Groundwater Depth: ~4 feet	Drill Rig Type: ATV track rig
	Drilling Method: 4" casing with water
Hammer Weight: 140 lbs	Split Spoon Diameter: ID - 1.375", OD - 2"
Hammer Type: Safety	Rock Core Barrel Size: N/A
Drop: 30 inches	

Depth Scale	Sample Depth (ft)	Sample No	Blows per 6 inches				Pen (in)	Rec (in)	Strata	Sample Description
			0-6	6-12	12-18	18-24				
10ft	0-2	S1	8	10	10	6	24	9		S1 - Heterogeneous layered Silty SAND (SM), fine to coarse and fine to medium, brown
	2-4	S2	7	8	8	8	24	5		S2 - Poorly Graded SAND with Silt (SP-SM), fine to medium, trace coarse, 10-15% fines, 5-10% gravel, dark brown, moist
	4-6	S3	3	2	3	2	24	9		S3 - Top 5": Well Graded SAND with Silt (SW-SM), fine to coarse, 10-15% fines, brown & rust, wet
	6-8	S4	1	2	6	17	24	5		Bottom 4": Fibrous PEAT (PT).
	8	S5	50/0"				0	0		S4 - Well Graded SAND with Silt (SW-SM), fine to coarse, 10-15% fines, 5-10% gravel, gray, wet. S5 - No recovery, spoon bouncing-Possible roots
20ft	10-12	S6	WOH	9	10	9	24	0	S6 - No recovery	
	14-16	S7	8	8	5	6	24	10	S7 - Silty SAND (SM), fine to medium, 15-20% fines, gray, wet	
	19-21	S8	8	8	8	9	24	0	S8 - No recovery. Redrove to retrieve sample, similar to S7	
	24-26	S9	4	6	5	7	24	4	S9 - Well Graded SAND with Silt(SW), fine to coarse, 5-10% fines, gray	

Remarks: 1. Bottom of peat based on blow counts.

Project:	Prop. Veterinary Hospital and Children's Zoo, Roger Williams Park Zoo, Providence, RI
Client:	Yoder + Tidwell, Ltd. LGCI Project No. 0917

Depth Scale	Sample Depth (ft)	Sample No	Blows per 6 inches				Pen (in)	Rec (in)	Strata	Sample Description
			0-6	6-12	12-18	18-24				
30 ft								SAND	S10 - Well Graded SAND with Silt Gravel (SW-SM), fine to coarse, 5-10% fines, 35-40% fine gravel, gray, wet S11 - No recovery. Wash consists of medium to coarse sand and fine gravel S12 - No recovery. Redrove sampler: fine to coarse sand, 5-10% fines, 5-10% fine gravel Bottom of boring at 41 ft, backfilled with cuttings.	
	29-31	S10	4	4	3	3	24			2
35 ft										
	34-36	S11	6	9	6	5	24			0
40 ft										
	39-41	S12	6	6	8	9	20			0
45 ft										
50 ft										
55 ft										

Remarks:

Project: Prop. Veterinary Hospital and Children's Zoo, Roger Williams Park Zoo, Providence, RI	
Client: Yoder + Tidwell, Ltd.	LGCI Project No.: 0917
Drilling Subcontractor: Subsurface Drilling	Date Started: 06/29/09
Drilling Foreman: Brad Haase	Date Completed: 06/29/09
LGCI Engineer: Jennifer MacGregor	Location: NW of children's zoo house
Ground Surface El: 32 interpolated from site plan	Total Depth: 17 feet
Groundwater Depth: 4.7 ft at end of drilling hole collapsed to 3.5 ft.	Drill Rig Type: ATV track rig
	Drilling Method: 4.25 hollow stem auger
Hammer Weight: 140 lbs	Split Spoon Diameter: ID - 1.375", OD - 2"
Hammer Type: Safety	Rock Core Barrel Size: N/A
Drop: 30 inches	

Depth Scale	Sample Depth (ft)	Sample No	Blows per 6 inches				Pen (in)	Rec (in)	Strata	Sample Description	
			0-6	6-12	12-18	18-24					
10ft	0-2	S1	6	12	35	33	24	13	Fill 7.2 ft	S1 - Top 4": Stone dust Middle 4": Silty SAND (SM), fine, 15-20% fines, brown, moist Bottom 5": Fractured gravel	
	2-3	S2	73	53			12	6		S2 - Well Graded SAND with Silt (SP-SM), fine to coarse, ~10% fines, ~15% gravel, brick in tip, brown, moist	
	5-7	S3	12	4	1	1	24	1		S3 - Poorly Graded SAND with Silt (SP-SM), fine to medium, 10-15% fines, gray, wet	
	7-9	S4	1	2	2	5	24	15		S4 - Top 2": Similar to S3	
										bottom 13": Fibrous PEAT (PT)	
										Peat 9.5 ft	
20ft	10-12	S5	8	7	6	5	24	18	Sand	S5 - Silty SAND (SM), fine to medium, 15-20% fines, gray, wet	
	15-17	S6	2	5	6	7	24	4		S6 - Silty SAND (SM), very fine to fine, 20-25% fines, gray, wet	

Remarks:

APPENDIX B - LGCI's Test Pit Logs

CLIENT: <u>Saccoccio & Associates, Inc.</u>	PROJECT NAME: <u>Proposed Education Center and Event Pavilion</u>
LGCI PROJECT NUMBER: <u>1911</u>	PROJECT LOCATION: <u>Providence, Rhode Island</u>
DATE STARTED: <u>8/7/19</u> DATE COMPLETED: <u>8/7/19</u>	EXCAVATION SUBCONTRACTOR: <u>Hoffman Environmental Services, Inc.</u>
TEST PIT LOCATION: <u>Northern Section of prop. Education Center footprint</u>	EXCAVATION FOREMAN: <u>Kyle Hoffman</u>
COORDINATES: <u>NA</u>	EXCAVATOR TYPE/MODEL: <u>CAT 303.5</u>
SURFACE EL.: <u>40 ft. (see note 1)</u> TOTAL DEPTH: <u>8.5 ft.</u>	WEATHER: <u>Partial sun, low 90's</u>
GROUNDWATER LEVELS:	TEST PIT DIMENSIONS: <u>7' X 2'</u>
▽ DURING EXCAVATION: <u>-</u>	LOGGED BY: <u>HA</u> CHECKED BY: <u>NP</u>
▽ AT END OF EXCAVATION: <u>N/E</u>	

Depth (ft)	El. (ft)	Excavation Effort	Remark	Strata	Depth El. (ft.)	Material Description	
		E		Forest Mat	0.4	0 ft. - 0.4 ft.: FOREST MAT (OL), nonfibrous, nonplastic, 25-30% organic fines, 35-40% fine sand, roots, leaves, black, moist	
		E		Subsoil	0.8	0.4 ft. - 0.8 ft.: Silty SAND (SM), fine, trace medium to coarse, 15-20% fines, trace organic soil, roots, brown, moist (appears reworked, possible fill)	
		E			39.2		
		E		Fill		0.8 ft. - 1 ft.: Silty SAND (SM), fine, 25-30% fines, light brown, moist	
		E					1 ft. - 2.3 ft.: Silty SAND (SM), fine, trace medium to coarse, 15-20% fines, roots, brown, moist
2.5	37.5	E					2.3 ft. - 3 ft.: Poorly Graded SAND (SM), fine, 0-5% fines, light brown, moist
		E					3 ft. - 8.5 ft.: Well Graded SAND with Gravel (GW), fine to coarse, 0-5% fines, ~15% fine to coarse subrounded gravel, brown, moist
5.0	35.0	E					
		E/M					
7.5	32.5						
					8.5	Bottom of test pit at 8.5 feet. Backfilled test pit with excavated material.	

GENERAL COMMENTS: **E = Easy, M - Moderate, D = Difficult, V = Very Difficult**

1. The ground surface elevation was interpolated to the nearest foot from drawing C-1.4 titled: "Grading & Drainage Plan, Education Center & Pavilion, Roger William Park Zoo," prepared by Garofalo & Associates, Inc. dated June 13, 2019 and e-mailed to LGCI by Garofalo & Associates, Inc. on September 19, 2019.

CLIENT: <u>Saccoccio & Associates, Inc.</u>	PROJECT NAME: <u>Proposed Education Center and Event Pavilion</u>
LGCI PROJECT NUMBER: <u>1911</u>	PROJECT LOCATION: <u>Providence, Rhode Island</u>
DATE STARTED: <u>8/7/19</u> DATE COMPLETED: <u>8/7/19</u>	EXCAVATION SUBCONTRACTOR: <u>Hoffman Environmental Services, Inc.</u>
TEST PIT LOCATION: <u>Center of prop. Education Center footprint</u>	EXCAVATION FOREMAN: <u>Kyle Hoffman</u>
COORDINATES: <u>NA</u>	EXCAVATOR TYPE/MODEL: <u>CAT 303.5</u>
SURFACE EL.: <u>40 ft. (see note 1)</u> TOTAL DEPTH: <u>8.1 ft.</u>	WEATHER: <u>Partial sun, low 90's</u>
GROUNDWATER LEVELS:	TEST PIT DIMENSIONS: <u>10' X 2'</u>
▽ DURING EXCAVATION: <u>-</u>	LOGGED BY: <u>HA</u> CHECKED BY: <u>NP</u>
▽ AT END OF EXCAVATION: <u>N/E</u>	

Depth (ft)	El. (ft)	Excavation Effort	Remark	Strata	Depth El. (ft.)	Material Description	
		E		Forest Mat	0.3	0 ft. - 0.3 ft.: FOREST MAT (OL), nonfibrous, nonplastic, 25-30% organic fines, 20-25% fine sand, roots, leaves, wood, black, moist	
		E		Subsoil	0.7		
		E			39.3		
2.5	37.5			Fill		0.3 ft. - 0.7 ft.: Silty SAND (SM), fine to medium, trace coarse, ~20% fines, ~10% fine to coarse subrounded gravel, trace organic soil, brown, moist (appears reworked, possible fill)	
		E					0.7 ft. - 1.1 ft.: Well Graded SAND with Silt and Gravel (SW-SM), fine to coarse, 10-15% fines, 15-20% fine subrounded to angular gravel, trace roots, light brown, moist
5.0	35.0						1.1 ft. - 6 ft.: Well Graded SAND (SW), fine to coarse, 0-5% fines, ~10% fine subrounded gravel, brown, moist
		E					
		E/M				6 ft. - 8.1 ft.: Well Graded SAND with Silt and Gravel (SW-SM), fine to coarse, 5-10% fines, 30-35% fine to coarse subrounded to angular gravel, ~10% cobbles and boulders up to 1.1' in size, brown, moist to wet	
7.5	32.5						
		M			8.1		
Bottom of test pit at 8.1 feet. Backfilled test pit with excavated material.							

GENERAL COMMENTS: E = Easy, M - Moderate, D = Difficult, V = Very Difficult

- The ground surface elevation was interpolated to the nearest foot from drawing C-1.4 titled: "Grading & Drainage Plan, Education Center & Pavilion, Roger William Park Zoo," prepared by Garofalo & Associates, Inc. dated June 13, 2019 and e-mailed to LGCI by Garofalo & Associates, Inc. on September 19, 2019.

CLIENT: <u>Saccoccio & Associates, Inc.</u>	PROJECT NAME: <u>Proposed Education Center and Event Pavilion</u>
LGCI PROJECT NUMBER: <u>1911</u>	PROJECT LOCATION: <u>Providence, Rhode Island</u>
DATE STARTED: <u>8/7/19</u> DATE COMPLETED: <u>8/7/19</u>	EXCAVATION SUBCONTRACTOR: <u>Hoffman Environmental Services, Inc.</u>
TEST PIT LOCATION: <u>SE corner of prop. Education Center footprint</u>	EXCAVATION FOREMAN: <u>Kyle Hoffman</u>
COORDINATES: <u>NA</u>	EXCAVATOR TYPE/MODEL: <u>CAT 303.5</u>
SURFACE EL.: <u>42 ft. (see note 1)</u> TOTAL DEPTH: <u>9.5 ft.</u>	WEATHER: <u>Partial sun, low 90's</u>
GROUNDWATER LEVELS:	TEST PIT DIMENSIONS: <u>7' X 2'</u>
▽ DURING EXCAVATION: <u>-</u>	LOGGED BY: <u>HA</u> CHECKED BY: <u>NP</u>
▽ AT END OF EXCAVATION: <u>-</u>	

Depth (ft)	El. (ft)	Excavation Effort	Remark	Strata	Depth El. (ft.)	Material Description
		E		Topsoil	0.3	0 ft. - 0.3 ft.: Topsoil
		E		Subsoil	0.9	0.3 ft. - 0.9 ft.: Silty SAND (SM), fine, trace medium, 20-25% fines, trace organic soil, roots, brown, moist (appears reworked, possible fill)
		E		Fill	41.1	0.9 ft. - 2.1 ft.: Poorly Graded SAND (SP), medium to coarse, trace fine, 0-5% fines, 5-10% fine subrounded gravel, trace organic soil, light brown, moist
	40.0	E			2.1 ft. - 2.5 ft.: Poorly Graded SAND (SP), fine, trace medium, 0-5% fines, trace roots, light brown, moist	
	2.5	E			2.5 ft. - 3.4 ft.: Poorly Graded SAND with Silt (SP-SM), fine, 5-10% fines, trace roots, light brown, moist	
		E			3.4 ft. - 9.5 ft.: Poorly Graded SAND (SP), fine to medium, 0-5% fines, light brown, moist	
	37.5					
	5.0					
		E				
	35.0					
	7.5					
	32.5				9.5	

Bottom of test pit at 9.5 feet. Backfilled test pit with excavated material.

GENERAL COMMENTS: E = Easy, M - Moderate, D = Difficult, V = Very Difficult

- The ground surface elevation was interpolated to the nearest foot from drawing C-1.4 titled: "Grading & Drainage Plan, Education Center & Pavilion, Roger William Park Zoo," prepared by Garofalo & Associates, Inc. dated June 13, 2019 and e-mailed to LGCI by Garofalo & Associates, Inc. on September 19, 2019.

CLIENT: <u>Saccoccio & Associates, Inc.</u>	PROJECT NAME: <u>Proposed Education Center and Event Pavilion</u>
LGCI PROJECT NUMBER: <u>1911</u>	PROJECT LOCATION: <u>Providence, Rhode Island</u>
DATE STARTED: <u>8/7/19</u> DATE COMPLETED: <u>8/7/19</u>	EXCAVATION SUBCONTRACTOR: <u>Hoffman Environmental Services, Inc.</u>
TEST PIT LOCATION: <u>SE corner of prop. Event Pavilion footprint</u>	EXCAVATION FOREMAN: <u>Kyle Hoffman</u>
COORDINATES: <u>NA</u>	EXCAVATOR TYPE/MODEL: <u>CAT 303.5</u>
SURFACE EL.: <u>30.5 ft. (see note 1)</u> TOTAL DEPTH: <u>7.5 ft.</u>	WEATHER: <u>Partial sun, low 90's</u>
GROUNDWATER LEVELS:	TEST PIT DIMENSIONS: <u>6' X 2'</u>
▽ DURING EXCAVATION: <u>7.1 ft. / El. 23.4 ft. Seeping</u>	LOGGED BY: <u>HA</u> CHECKED BY: <u>NP</u>
▼ AT END OF EXCAVATION: <u>7.5 ft. / El. 23.0 ft. Pooling</u>	

Depth (ft)	El. (ft)	Excavation Effort	Remark	Strata	Depth El. (ft.)	Material Description
	30.0	E		Fill		0.1 ft. - 2.7 ft.: Silty SAND (SM), fine to medium, trace coarse, 15-20% fines, ~10% fine subrounded gravel, wood, roots, moist
2.5		E				2.7 ft. - 5.1 ft.: Silty SAND with Gravel (SM), fine to medium, trace coarse, 15-20% fines, 20-25% fine to coarse subangular to angular gravel, 15-20% cobbles and boulders up to 1' in size, roots, brown, moist
	27.5	H				
5.0		E				
	25.0	E				
		E		Silt	6.5	6.5 ft. - 7.5 ft.: SILT with Sand (ML), nonplastic, 15-20% fine sand, trace roots, gray, wet
7.5					7.5	▼ Bottom of test pit at 7.5 feet. Backfilled test pit with excavated material.

GENERAL COMMENTS: E = Easy, M - Moderate, D = Difficult, V = Very Difficult

- The ground surface elevation was interpolated to the nearest foot from drawing C-1.4 titled: "Grading & Drainage Plan, Education Center & Pavilion, Roger William Park Zoo," prepared by Garofalo & Associates, Inc. dated June 13, 2019 and e-mailed to LGCI by Garofalo & Associates, Inc. on September 19, 2019.

THIS PAGE INTENTIONALLY LEFT BLANK

APPENDIX C - LGCI's Boring Logs

CLIENT: <u>Saccoccio & Associates, Inc.</u>	PROJECT NAME: <u>Proposed Education Center and Event Pavilion</u>
LGCI PROJECT NUMBER: <u>1911</u>	PROJECT LOCATION: <u>Providence, Rhode Island</u>
DATE STARTED: <u>8/9/19</u> DATE COMPLETED: <u>8/9/19</u>	DRILLING SUBCONTRACTOR: <u>Hoffman Environmental Services, Inc.</u>
BORING LOCATION: <u>Western side of prop. Education Center</u>	DRILLING FOREMAN: <u>Kyle Hoffman</u>
COORDINATES: <u>NA</u>	DRILLING METHOD: <u>Hollow Stem Auger (4-1/4" I.D.)</u>
SURFACE EI.: <u>37 ft. (see note 1)</u> TOTAL DEPTH: <u>22 ft.</u>	DRILL RIG TYPE/MODEL: <u>Diedrich D-25</u>
WEATHER: <u>Partial sun, low 80's</u>	HAMMER TYPE: <u>Automatic</u>
GROUNDWATER LEVELS:	HAMMER WEIGHT: <u>140 lb.</u> HAMMER DROP: <u>30 in.</u>
▽ DURING DRILLING: <u>-</u>	SPLIT SPOON DIA.: <u>1.375 in. I.D., 2 in. O.D.</u>
▽ AT END OF DRILLING: <u>6.3 ft. / El. 30.7 ft.</u>	CORE BARREL SIZE: <u>NA</u>
▽ OTHER: <u>11.0 ft. / El. 26.0 ft. Based on soil sample moisture</u>	LOGGED BY: <u>BM</u> CHECKED BY: <u>NP</u>

Depth (ft.)	El. (ft.)	Sample Interval (ft.)	Sample Number	Blow Counts (N Value)	Pen./Rec. (in.)	Remark	Strata	Material Description
		0					Topsoil	
			S1	3-5-8-12 (13)	24/7		Fill	S1 - Top 3": Topsoil Bot. 4": Silty SAND (SM), fine to medium, 15-20% fines, ~10% fine subrounded gravel, trace organic soil, trace roots, light brown, moist
35.0		2	S2	5-8-3-13 (11)	24/3			S2 - Similar to bot. 4" of S1, brown
5		4						
		5	S3	7-4-3-3 (7)	24/3			S3 - Poorly Graded SAND with Silt and Gravel (SP-SM), fine to medium, 10-15% fines, 20-25% subrounded gravel, trace roots, light brown, moist
30.0		7						▽
10		10	S4	4-4-8-7 (12)	24/7			S4 - Silty SAND with Gravel (SM), fine to medium, trace coarse, 30-35% fines, 15-20% subrounded gravel, light brown to gray, wet
25.0		12						▽
15		15	S5	6-3-4-4 (7)	24/8			S5 - Top 3": Similar to S4, gray, 20-25% fines Bot. 5": Poorly Graded Sand with Silt (SP-SM), fine to medium, 5-10% fines, 0-5% gravel, gray, wet (possible swamp deposits)
20.0		17						
20		20	S6	7-9-6-5 (15)	24/5		Sand	S6 - Poorly Graded SAND with Silt and Gravel (SP-SM), fine to medium, trace coarse, 5-10% fines, 15-20% subrounded gravel, gray, wet
15.0		22						
25								Bottom of borehole at 22.0 feet. Backfilled borehole with drill cuttings and a 1/3 of a bag of sand.

GENERAL NOTES:

1. The ground surface elevation was interpolated to the nearest foot from drawing C-1.4 titled: "Grading & Drainage Plan, Education Center & Pavilion, Roger William Park Zoo," prepared by Garofalo & Associates, Inc. dated June 13, 2019 and e-mailed to LGCI by Garofalo & Associates, Inc. on September 19, 2019.

CLIENT: <u>Saccoccio & Associates, Inc.</u>	PROJECT NAME: <u>Proposed Education Center and Event Pavilion</u>
LGCI PROJECT NUMBER: <u>1911</u>	PROJECT LOCATION: <u>Providence, Rhode Island</u>
DATE STARTED: <u>8/12/19</u> DATE COMPLETED: <u>8/12/19</u>	DRILLING SUBCONTRACTOR: <u>Hoffman Environmental Services, Inc.</u>
BORING LOCATION: <u>Northern side of prop. Education Center footprint</u>	DRILLING FOREMAN: <u>Kyle Hoffman</u>
COORDINATES: <u>NA</u>	DRILLING METHOD: <u>Drive and wash with 3-inch casing</u>
SURFACE EI.: <u>40 ft. (see note 1)</u> TOTAL DEPTH: <u>30 ft.</u>	DRILL RIG TYPE/MODEL: <u>Diedrich D-25</u>
WEATHER: <u>Partial sun, high 70's</u>	HAMMER TYPE: <u>Automatic</u>
GROUNDWATER LEVELS:	HAMMER WEIGHT: <u>140 lb.</u> HAMMER DROP: <u>30 in.</u>
▽ DURING DRILLING: <u>-</u>	SPLIT SPOON DIA.: <u>1.375 in. I.D., 2 in. O.D.</u>
▽ AT END OF DRILLING: <u>-</u>	CORE BARREL SIZE: <u>NA</u>
▽ OTHER: <u>6.0 ft. / El. 34.0 ft. Based on soil sample moisture.</u>	LOGGED BY: <u>AML</u> CHECKED BY: <u>NP</u>

Depth (ft.)	El. (ft.)	Sample Interval (ft.)	Sample Number	Blow Counts (N Value)	Pen./Rec. (in.)	Remark	Strata	Material Description	
		0					Topsoil	S1 - Top 6": Topsoil	
		2	S1	3-3-4-5 (7)	24/12		Fill	Bot. 6": Silty SAND (SM), fine to medium, trace coarse, ~20% fines, 5-10% fine gravel, trace of organic soil, dark brown to brown, moist (fill)	
		4	S2	5-6-8-7 (14)	24/10			S2 - Silty SAND (SM), fine to medium, trace coarse, ~15% fines, 5-10% fine gravel, brown, moist	
5	35.0	6	S3	8-9-7-8 (16)	24/12			S3 - Silty SAND with Gravel (SM), fine to medium, trace coarse, ~15% fines, ~15% fine gravel, brown, moist	
		6				1		REMARK 1: Started with water at 6'. S4 - Silty SAND with Gravel (SM), fine to coarse, ~15% fines, ~30% fine gravel, trace of roots, brown, wet	
		8	S4	7-7-10-13 (17)	24/5		Sand	S5 - Similar to S4, 30-35% fine gravel	
10	30.0	10	S5	9-9-8-10 (17)	24/3				
		14				2			REMARK 2: Losing water at 14'. S6 - Mostly wash material, possibly pushing at cobbles
15	25.0	16	S6	22-24-17-17 (41)	24/0				
		18	S7	5-4-3-4 (7)	24/9				S7 - Well Graded SAND with Silt (SW-SM), fine to coarse, 10-15% fines, 10-15% fine gravel, brown, wet
		19						S8 - Poorly Graded SAND with Silt (SP-SM), medium to coarse, trace fine, 10-15% fines, 10-15% fine gravel, brown, wet	
20	20.0	21	S8	11-6-6-5 (12)	24/5				
		24				3		REMARK 3: Less effort driving casing at ~23'. S9 - No recovery	
25	15.0			12-13-4-3					

GENERAL NOTES:

1. The ground surface elevation was interpolated to the nearest foot from drawing C-1.4 titled: "Grading & Drainage Plan, Education Center & Pavilion, Roger William Park Zoo," prepared by Garofalo & Associates, Inc. dated June 13, 2019 and e-mailed to LGCI by Garofalo & Associates, Inc. on September 19, 2019.

CLIENT: <u>Saccoccio & Associates, Inc.</u>	PROJECT NAME: <u>Proposed Education Center and Event Pavilion</u>
LGCI PROJECT NUMBER: <u>1911</u>	PROJECT LOCATION: <u>Providence, Rhode Island</u>
DATE STARTED: <u>8/9/19</u> DATE COMPLETED: <u>8/9/19</u>	DRILLING SUBCONTRACTOR: <u>Hoffman Environmental Services, Inc.</u>
BORING LOCATION: <u>Eastern side of prop. Education Center</u>	DRILLING FOREMAN: <u>Kyle Hoffman</u>
COORDINATES: <u>NA</u>	DRILLING METHOD: <u>Hollow Stem Auger (4-1/4" I.D.)</u>
SURFACE EI.: <u>42 ft. (see note 1)</u> TOTAL DEPTH: <u>22 ft.</u>	DRILL RIG TYPE/MODEL: <u>Diedrich D-25</u>
WEATHER: <u>Partial sun, low 80's</u>	HAMMER TYPE: <u>Automatic</u>
GROUNDWATER LEVELS:	HAMMER WEIGHT: <u>140 lb.</u> HAMMER DROP: <u>30 in.</u>
▽ DURING DRILLING: <u>-</u>	SPLIT SPOON DIA.: <u>1.375 in. I.D., 2 in. O.D.</u>
▽ AT END OF DRILLING: <u>-</u>	CORE BARREL SIZE: <u>NA</u>
▽ OTHER: <u>15.0 ft. / El. 27.0 ft. Based on soil sample moisture.</u>	LOGGED BY: <u>BM</u> CHECKED BY: <u>NP</u>

Depth (ft.)	El. (ft.)	Sample Interval (ft.)	Sample Number	Blow Counts (N Value)	Pen./Rec. (in.)	Remark	Strata	Depth El. (ft.)	Material Description
							Asphalt	0.5	
	40.0	1	S1	11-8	12/8		Fill		S1 - Poorly Graded SAND with Silt (SP-SM), fine to medium, 5-10% fines, ~5% fine subrounded gravel, light brown, moist
		2	S2	8-6-6-8 (12)	24/9			S2 - Poorly Graded SAND with Silt (SP-SM), fine to medium, trace coarse, 5-10% fines, 5% fine subrounded gravel, light brown, moist	
5		4							
		5					Sand		S3 - Silty SAND (SM), fine to medium, 15-20% fines, 5-10% fine subrounded to subangular gravel, light brown, moist
	35.0	7	S3	7-5-4-3 (9)	24/13			7.0	
	10	10	S4	6-9-10-8 (19)	24/6				S4 - Poorly Graded SAND with Silt and Gravel (SP-SM), fine to medium, 10-15% fines, 15% subrounded gravel, light brown to gray, moist
	30.0	12							
	15	15	S5	7-8-8-10 (16)	24/12				▽ S5 - Top 6": Well Graded GRAVEL (GW), fine to coarse, 0-5% fines, 30-35% fine to coarse sand, light brown, wet Bot. 6": Silty SAND (SM), fine to coarse, ~20% fines, 10-15% subrounded gravel, light brown, moist
	25.0	17							
	20	20	S6	10-16-14-14 (30)	24/5				S6 - Silty SAND with Gravel (SM), ~20% fines, 15-20% subrounded gravel, light brown to gray, wet
	20.0	22				1		22.0	REMARK 1: Ending boring at 22 feet due to auger rising with split spoon sampler casing running sand. Bottom of borehole at 22.0 feet. Backfilled borehole with drill cuttings and a 1/2 of a bag of sand. Ground surface restored with cold patch asphalt.
	25								

GENERAL NOTES:

- The ground surface elevation was interpolated to the nearest foot from drawing C-1.4 titled: "Grading & Drainage Plan, Education Center & Pavilion, Roger William Park Zoo," prepared by Garofalo & Associates, Inc. dated June 13, 2019 and e-mailed to LGCI by Garofalo & Associates, Inc. on September 19, 2019.

CLIENT: <u>Saccoccio & Associates, Inc.</u>	PROJECT NAME: <u>Proposed Education Center and Event Pavilion</u>
LGCI PROJECT NUMBER: <u>1911</u>	PROJECT LOCATION: <u>Providence, Rhode Island</u>
DATE STARTED: <u>8/8/19</u> DATE COMPLETED: <u>8/8/19</u>	DRILLING SUBCONTRACTOR: <u>Hoffman Environmental Services, Inc.</u>
BORING LOCATION: <u>Southern side of prop. Education Center</u>	DRILLING FOREMAN: <u>Kyle Hoffman</u>
COORDINATES: <u>NA</u>	DRILLING METHOD: <u>Drive and wash with 4-inch casing</u>
SURFACE EI.: <u>45 ft. (see note 1)</u> TOTAL DEPTH: <u>34 ft.</u>	DRILL RIG TYPE/MODEL: <u>Diedrich D-25</u>
WEATHER: <u>Partial sun, low 80's</u>	HAMMER TYPE: <u>Automatic</u>
GROUNDWATER LEVELS:	HAMMER WEIGHT: <u>140 lb.</u> HAMMER DROP: <u>30 in.</u>
▽ DURING DRILLING: <u>-</u>	SPLIT SPOON DIA.: <u>1.375 in. I.D., 2 in. O.D.</u>
▽ AT END OF DRILLING: <u>6.1 ft. / El. 38.9 ft.</u>	CORE BARREL SIZE: <u>NA</u>
▽ OTHER: <u>-</u>	LOGGED BY: <u>BM</u> CHECKED BY: <u>NP</u>

Depth (ft.)	El. (ft.)	Sample Interval (ft.)	Sample Number	Blow Counts (N Value)	Pen./Rec. (in.)	Remark	Strata	Material Description	
		0					Topsoil	S1 - Top 7": Topsoil	
		2	S1	3-4-3-3 (7)	24/14		Buried Organic Soil	Bot. 7": Poorly Graded SAND (SP-SM), fine to medium, 10-15% fines, ~5% subangular gravel, trace organic soil, light brown, moist	
		4	S2	3-2-4-5 (6)	24/10			S2 - Silty SAND with Gravel (SM), fine to medium, 15-20% fines, 10-15% fine to coarse subrounded gravel, trace organic soil, roots, orange to brown, moist	
5	40.0	4	S3	6-5-7-10 (12)	24/14		Fill	S3 - Top 5": Silty SAND (SM), fine to medium, 15-20% fines, ~5% subrounded gravel, trace roots, brown, moist	
		6	S4	10-12-12-11 (24)	24/7			Bot. 9": Well Graded SAND with Silt and Gravel (SW-SM), fine to coarse, 10-15% fines, 15-20% fine to coarse subrounded gravel, gray, moist	
		8	S5	4-10-15-12 (25)	24/12			S4 - Silty SAND with Gravel (SM), fine to medium, 15-20% fines, 20-25% subrounded gravel, gray, wet	
		10	S6	6-8-8-7 (16)	24/14			S5 - Silty GRAVEL with Sand (GM), fine, ~20% fines, 30-35% fine to coarse sand, gray, wet	
		12	S7	8-8-8-7 (16)	24/6			S6 - Silty SAND with Gravel (SM), fine to coarse, ~20% fines, 15-20% fine subrounded gravel, light brown, wet	
15	30.0	14	S8	7-7-12-11 (19)	24/2			S7 - Silty SAND with Gravel (SM), fine to coarse, 15-20% fines, 15-20% fine subrounded gravel, light brown, wet	
		16	S9	8-7-6-6 (13)	24/11			S8 - Silty GRAVEL with Sand (GM), fine subrounded to subangular gravel, ~20% fines, 20-25% fine to coarse sand subrounded to subangular gravel, gray, wet	
		18	S10	8-7-6-8 (13)	24/10			Buried Organic Soil	S9 - Top 9": Silty SAND with Gravel (SM), fine to medium, 20-25% fines, ~15% coarse subangular gravel, light brown, wet
		20						Sand	Bot. 2": Silty SAND (SM), fine to medium, trace of organic soil, trace of fibrous peat, dark brown, wet (buried organic soil)
25	20.0	20							S10 - Silty SAND(SM), fine to coarse, 20-25% fines, 10-15% fine gravel, brown, wet

GENERAL NOTES:

1. The ground surface elevation was interpolated to the nearest foot from drawing C-1.4 titled: "Grading & Drainage Plan, Education Center & Pavilion, Roger William Park Zoo," prepared by Garofalo & Associates, Inc. dated June 13, 2019 and e-mailed to LGCI by Garofalo & Associates, Inc. on September 19, 2019.

CLIENT: Saccoccio & Associates, Inc. **PROJECT NAME:** Proposed Education Center and Event Pavilion
LGCI PROJECT NUMBER: 1911 **PROJECT LOCATION:** Providence, Rhode Island

Depth (ft.)	El. (ft.)	Sample Interval (ft.)	Sample Number	Blow Counts (N Value)	Pen./Rec. (in.)	Remark	Strata	Material Description
		25	S11	5-4-5-6 (9)	24/14		Sand	S11 - Similar to S10, gray to light brown
		27						
30	15.0	30	S12	8-6-7-8 (13)	24/8			S12 - Similar to S11
		32	S13	10-6-5-4 (11)	24/4			S13 - Similar to S11, gray
		34						Bottom of borehole at 34.0 feet. Backfilled borehole with drill cuttings and a 1/3 of a bag of sand.
35	10.0							
40	5.0							
45	0.0							
50	-5.0							
55	-10.0							
60	-15.0							

CLIENT: <u>Saccoccio & Associates, Inc.</u>	PROJECT NAME: <u>Proposed Education Center and Event Pavilion</u>
LGCI PROJECT NUMBER: <u>1911</u>	PROJECT LOCATION: <u>Providence, Rhode Island</u>
DATE STARTED: <u>8/8/19</u> DATE COMPLETED: <u>8/9/19</u>	DRILLING SUBCONTRACTOR: <u>Hoffman Environmental Services, Inc.</u>
BORING LOCATION: <u>Center of prop. Education Center</u>	DRILLING FOREMAN: <u>Kyle Hoffman</u>
COORDINATES: <u>NA</u>	DRILLING METHOD: <u>Drive and wash with 3-inch casing</u>
SURFACE EI.: <u>44.5 ft. (see note 1)</u> TOTAL DEPTH: <u>31 ft.</u>	DRILL RIG TYPE/MODEL: <u>Diedrich D-25</u>
WEATHER: <u>Partial sun, low 80's</u>	HAMMER TYPE: <u>Automatic</u>
GROUNDWATER LEVELS:	HAMMER WEIGHT: <u>140 lb.</u> HAMMER DROP: <u>30 in.</u>
▽ DURING DRILLING: <u>-</u>	SPLIT SPOON DIA.: <u>1.375 in. I.D., 2 in. O.D.</u>
▽ AT END OF DRILLING: <u>6.5 ft. / El. 38.0 ft.</u>	CORE BARREL SIZE: <u>NA</u>
▽ OTHER: <u>-</u>	LOGGED BY: <u>BM</u> CHECKED BY: <u>NP</u>

Depth (ft.)	El. (ft.)	Sample Interval (ft.)	Sample Number	Blow Counts (N Value)	Pen./Rec. (in.)	Remark	Strata	Material Description
		0					Forest Mat	
		0	S1	5-4-5-4 (9)	24/10		Fill	S1 - Top 3": FOREST MAT (OL), fibrous, nonplastic, 30-35% organic fines, 5-10% fine sand, trace root, brown, moist Bot. 7": Silty SAND (SM), fine to medium, ~15% fines, ~5% subrounded gravel, trace root, light brown, moist
		2	S2	10-12-9-9 (21)	24/2			S2 - Silty SAND (SM), fine to medium, 20-25% fines, ~5% subrounded gravel, brown, moist
5	40.0	4	S3	8-8-9-6 (17)	24/7			S3 - Well Graded SAND with Silt and Gravel (SW-SM), fine to coarse, 5-10% fines, 25-30% fine subrounded gravel, light brown, dry
		6						▽
10	35.0	9	S4	11-11-11-19 (22)	24/9			S4 - Silty SAND with Gravel (SM), fine to medium, 20-25% fines, 15-20% subrounded to angular gravel, light brown to gray, wet
		11						
15	30.0	14	S5	12-19-21-19 (40)	24/4			S5 - Silty GRAVEL (GM), fine to coarse angular, 25-30% fines, 10-15% fine sand, gray, wet
		16					16.0	
20	25.0	19	S6	12-10-9-10 (19)	24/10		Sand	S6 - Silty SAND with Gravel (SM), fine to coarse, 20-25% fines, ~15% subrounded gravel, light brown, wet
		21						
25	20.0	24		10-9-11-13				S7 - No recovery

GENERAL NOTES:

1. The ground surface elevation was interpolated to the nearest foot from drawing C-1.4 titled: "Grading & Drainage Plan, Education Center & Pavilion, Roger William Park Zoo," prepared by Garofalo & Associates, Inc. dated June 13, 2019 and e-mailed to LGCI by Garofalo & Associates, Inc. on September 19, 2019.

CLIENT: Saccoccio & Associates, Inc. **PROJECT NAME:** Proposed Education Center and Event Pavilion
LGCI PROJECT NUMBER: 1911 **PROJECT LOCATION:** Providence, Rhode Island

Depth (ft.)	El. (ft.)	Sample Interval (ft.)	Sample Number	Blow Counts (N Value)	Pen./Rec. (in.)	Remark	Strata	Material Description
24			S7	(20)	24/0		Sand	S8 - Silty SAND with Gravel (SM), fine to coarse, 20-25% fines, ~15% fine subrounded gravel, gray, wet
26								
29	15.0		S8	9-8-7-8 (15)	24/8			
30								
31								Bottom of borehole at 31.0 feet. Backfilled borehole with drill cuttings and a 1/3 of a bag of sand.
35	10.0							
40	5.0							
45	0.0							
50	-5.0							
55	-10.0							
60	-15.0							

CLIENT: <u>Saccoccio & Associates, Inc.</u>	PROJECT NAME: <u>Proposed Education Center and Event Pavilion</u>
LGCI PROJECT NUMBER: <u>1911</u>	PROJECT LOCATION: <u>Providence, Rhode Island</u>
DATE STARTED: <u>8/6/19</u> DATE COMPLETED: <u>8/6/19</u>	DRILLING SUBCONTRACTOR: <u>Hoffman Environmental Services, Inc.</u>
BORING LOCATION: <u>SW corner of prop. Event Pavilion</u>	DRILLING FOREMAN: <u>Kyle Hoffman</u>
COORDINATES: <u>NA</u>	DRILLING METHOD: <u>Drive and wash with 3-inch casing then open hole</u>
SURFACE EI.: <u>33 ft. (see note 1)</u> TOTAL DEPTH: <u>52 ft.</u>	DRILL RIG TYPE/MODEL: <u>Diedrich D-25</u>
WEATHER: <u>Partial sun, low 90's</u>	HAMMER TYPE: <u>Automatic</u>
GROUNDWATER LEVELS:	HAMMER WEIGHT: <u>140 lb.</u> HAMMER DROP: <u>30 in.</u>
▽ DURING DRILLING: <u>4.5 ft. / El. 28.5 ft. Based on soil sample moisture</u>	SPLIT SPOON DIA.: <u>1.375 in. I.D., 2 in. O.D.</u>
▽ AT END OF DRILLING: <u>6.8 ft. / El. 26.2 ft.</u>	CORE BARREL SIZE: <u>NA</u>
▽ OTHER: <u>-</u>	LOGGED BY: <u>HA</u> CHECKED BY: <u>NP</u>

Depth (ft.)	El. (ft.)	Sample Interval (ft.)	Sample Number	Blow Counts (N Value)	Pen./Rec. (in.)	Remark	Strata	Depth El. (ft.)	Material Description
		0.5					Asphalt	0.2	
		2.5	S1	2-2-2-1 (4)	24/9		Fill		S1 - Silty SAND (SM), fine to medium, trace coarse, 15-20% fines, 0-5% fine to coarse angular gravel, trace organic soil, brown, moist
30.0		4.5	S2	3-3-4-3 (7)	24/10				S2 - Silty SAND (SM), fine to coarse, ~20% fines, 5-10% fine subrounded grave, trace organic soil, brown, moist
5		6	S3	2-2-1	18/9			4.9	▽ S3 - Top 4": Silty SAND (SM), fine to medium, trace coarse, 20-25% fines, wood, brown, wet Bot. 5": PEAT (PT), fibrous, 10-15% fines to medium sand, black, wet
							Peat		▽
25.0		9	S4	5-2-3-1 (5)	24/5				S4 - Top 3": Silty SAND (SM), fine to medium, 20-25% fines, gray, wet Bot. 2": PEAT (PT), fibrous, 20-25% fine to medium sand, black, wet
10		14	S5	1-1-1-2 (2)	24/24				S5 - PEAT (PT), fibrous, 5-10% fine sand, black to brown, wet
15		16							
		19	S6	1-1-1-1 (2)	24/24		Silt	19.0	S6 - SILT with Sand (ML), slightly plastic, 15-20% fine sand, trace organic soil, gray, wet
20		21							
		24					Sand	24.0	S7 - Silty SAND (SM), fine to coarse, ~20% fines, gray, wet
25				6-12-8-5					

GENERAL NOTES:

1. The ground surface elevation was interpolated to the nearest foot from drawing C-1.4 titled: "Grading & Drainage Plan, Education Center & Pavilion, Roger William Park Zoo," prepared by Garofalo & Associates, Inc. dated June 13, 2019 and e-mailed to LGCI by Garofalo & Associates, Inc. on September 19, 2019.

CLIENT: Saccoccio & Associates, Inc.

 PROJECT NAME: Proposed Education Center and Event Pavilion

 LGCI PROJECT NUMBER: 1911

 PROJECT LOCATION: Providence, Rhode Island

Depth (ft.)	EI. (ft.)	Sample Interval (ft.)	Sample Number	Blow Counts (N Value)	Pen./Rec. (in.)	Remark	Strata	Material Description
24			S7	(20)	24/5		Sand	
26								
5.0								
29			S8	5-5-4-6 (9)	24/10			S8 - Poorly Graded SAND (SP), fine to medium, trace coarse, 0-5% fines, gray, wet
30								
31			S9	4-5-4-3 (9)	24/13			S9 - Similar to S8
33								
0.0								
35								
35			S10	3-4-3-4 (7)	24/11			S10 - Similar to S8
37								
-5.0								
40			S11	5-6-8-10 (14)	24/24			S11 - Similar to S8, 1/4" layer of coarse sand
42								
-10.0								
45			S12	6-6-6-4 (12)	24/11		S12 - Silty SAND with Gravel (SM), fine to coarse, 20-25% fines, ~15% fine subrounded gravel, gray, wet	
47								
-15.0								
50			S13	7-6-5-6 (11)	24/3		S13 - Silty GRAVEL with Sand (GM), fine, subrounded, 15-20% fines, 30-35% fine to coarse sand, gray, wet	
52								
-20.0								
55								
-25.0								
60								
								52.0 Bottom of borehole at 52.0 feet. Backfilled borehole with drill cuttings. Ground surface restored with cold patch asphalt.

CLIENT: <u>Saccoccio & Associates, Inc.</u>	PROJECT NAME: <u>Proposed Education Center and Event Pavilion</u>
LGCI PROJECT NUMBER: <u>1911</u>	PROJECT LOCATION: <u>Providence, Rhode Island</u>
DATE STARTED: <u>8/6/19</u> DATE COMPLETED: <u>8/6/19</u>	DRILLING SUBCONTRACTOR: <u>Hoffman Environmental Services, Inc.</u>
BORING LOCATION: <u>NE corner of prop. Event Pavilion</u>	DRILLING FOREMAN: <u>Kyle Hoffman</u>
COORDINATES: <u>NA</u>	DRILLING METHOD: <u>Drive and wash with 3-inch casing then open hole</u>
SURFACE EI.: <u>33 ft. (see note 1)</u> TOTAL DEPTH: <u>32 ft.</u>	DRILL RIG TYPE/MODEL: <u>Diedrich D-25</u>
WEATHER: <u>Partial sun, low 90's</u>	HAMMER TYPE: <u>Automatic</u>
GROUNDWATER LEVELS:	HAMMER WEIGHT: <u>140 lb.</u> HAMMER DROP: <u>30 in.</u>
▽ DURING DRILLING: <u>-</u>	SPLIT SPOON DIA.: <u>1.375 in. I.D., 2 in. O.D.</u>
▽ AT END OF DRILLING: <u>5.4 ft. / El. 27.6 ft.</u>	CORE BARREL SIZE: <u>NA</u>
▽ OTHER: <u>-</u>	LOGGED BY: <u>HA</u> CHECKED BY: <u>NP</u>

Depth (ft.)	El. (ft.)	Sample Interval (ft.)	Sample Number	Blow Counts (N Value)	Pen./Rec. (in.)	Remark	Strata	Depth El. (ft.)	Material Description
		0					Topsoil		S1 - Poorly Graded SAND with Silt and Gravel (SP-SM), fine to medium, trace coarse, 10-15% fines, ~15% fine to coarse subrounded to angular gravel, trace organic soil, trace roots, trace bricks, brown, moist
		2	S1	6-9-10-7 (19)	24/9			2.0	
	30.0		S2	4-3-3-3 (6)	24/12		Fill		S2 - Silty SAND (SM), fine to medium, trace coarse, 15-20% fines, trace organic soil, brown, moist
	5	4	S3	4-4-3-14 (7)	24/3				S3 - Silty SAND (SM), fine to medium, trace coarse, ~25% fines, trace organic soil, ~10% fine subrounded gravel, brown, moist
	25.0	6	S4	8-6-5-7 (11)	24/4				S4 - Silty SAND with Gravel (SM), fine to medium, trace coarse, 30-35% fines, 15-20% fine to coarse subrounded gravel, gray moist
	10	10	S5	2-2-4-4 (6)	24/11				S5 - Silty SAND (SM), fine, trace medium, 30-35% fines, gray, wet
	20.0	12							
	15	15				1			REMARK 1: Change in color of outwash to black at ~14'.
		17	S6	1-2-1-1 (3)	24/24	2		15.0	REMARK 2: Strata changed assumed at 15'. S6 - PEAT (PT), fibrous, slightly plastic, 5-10% fine sand, black, wet
	15.0						Peat		
	20	20				3			REMARK 3: Change in color of outwash to gray at ~19'.
		22	S7	3-1-1-3 (2)	24/4			20.0	S7 - Poorly Graded SAND with Silt (SP-SM), fine to medium, trace coarse, 10-15% fines, gray, wet
	10.0						Sand		
	25								

GENERAL NOTES:

1. The ground surface elevation was interpolated to the nearest foot from drawing C-1.4 titled: "Grading & Drainage Plan, Education Center & Pavilion, Roger William Park Zoo," prepared by Garofalo & Associates, Inc. dated June 13, 2019 and e-mailed to LGCI by Garofalo & Associates, Inc. on September 19, 2019.

THIS PAGE INTENTIONALLY LEFT BLANK

APPENDIX D - Laboratory Test Results

Particle Size Distribution Report

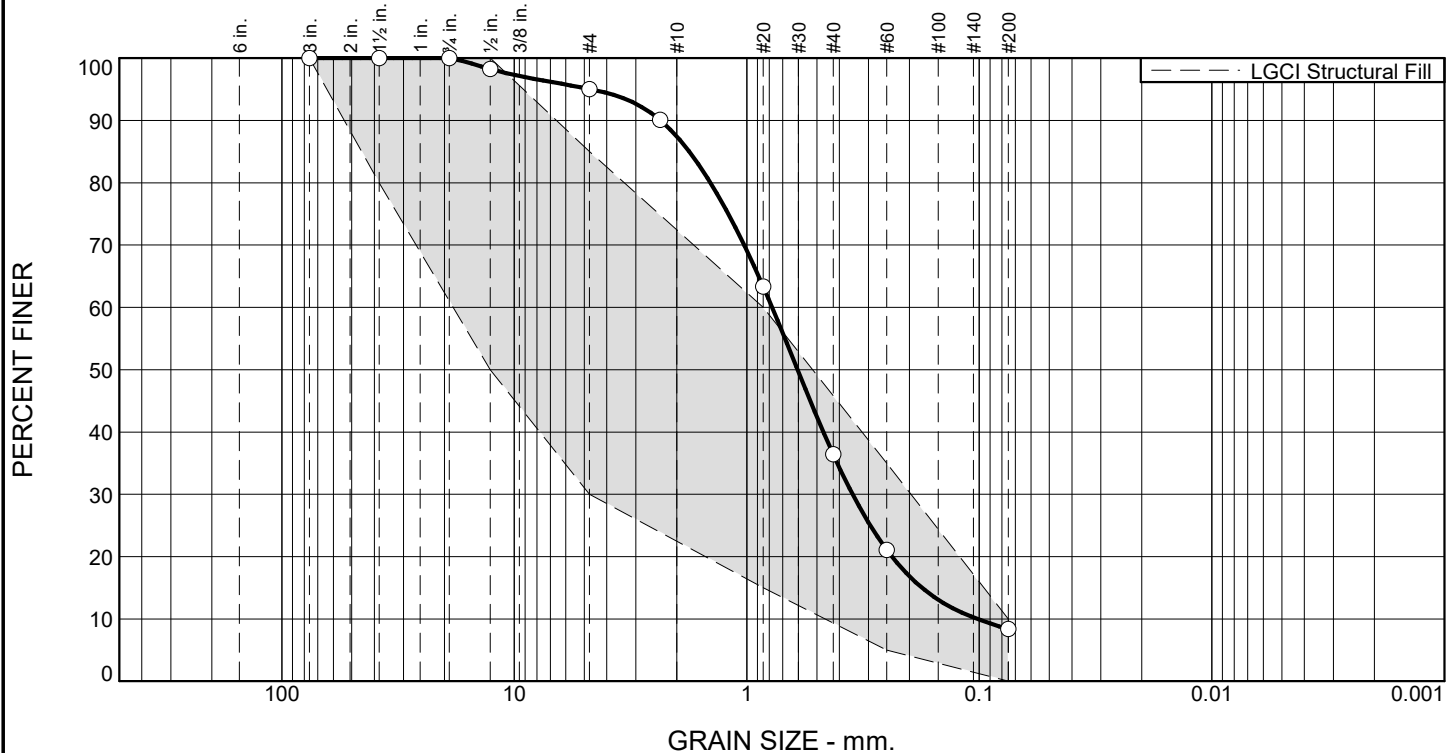

% +3"	% Gravel		% Sand			% Fines	
	Coarse	Fine	Coarse	Medium	Fine	Silt	Clay
0.0	0.0	5.0	7.6	51.0	28.0	8.4	

TEST RESULTS			
Opening Size	Percent Finer	Spec.* (Percent)	Pass? (X=Fail)
3"	100.0	100.0	
1.5"	100.0	80.0 - 100.0	
0.75"	100.0	80.0 - 100.0	
0.5"	98.3	50.0 - 100.0	
#4	95.0	30.0 - 85.0	X
#8	90.1	30.0 - 85.0	
#20	63.3	15.0 - 60.0	X
#40	36.4	15.0 - 60.0	
#60	21.1	5.0 - 35.0	
#200	8.4	0.0 - 10.0	

Material Description

ASTM (D 2488) Classification: Poorly Graded SAND with Silt (SP-SM), fine to medium, trace coarse, 5-10% fines, 5% fine subrounded gravel, light brown, moist

Atterberg Limits (ASTM D 4318)

PL= _____ LL= _____ PI= _____

Classification

USCS (D 2487)= _____ AASHTO (M 145)= _____

Coefficients

D₉₀= 2.3450 D₈₅= 1.7663 D₆₀= 0.7785
 D₅₀= 0.6051 D₃₀= 0.3504 D₁₅= 0.1761
 D₁₀= 0.1020 C_u= 7.63 C_c= 1.55

Remarks

Fill sample.

Date Received: 8/8/2019 Date Tested: 9/6/2019

Tested By: NP

Checked By: AML

* LGCI Structural Fill

Location: B-3 Sample Number: S2 Depth: 2'-4' Date Sampled: 8/8/2019



Client: Saccoccio & Associates, Inc.
 Project: Proposed Education Center and Event Pavillion
 Project No: 1911 Figure

Particle Size Distribution Report

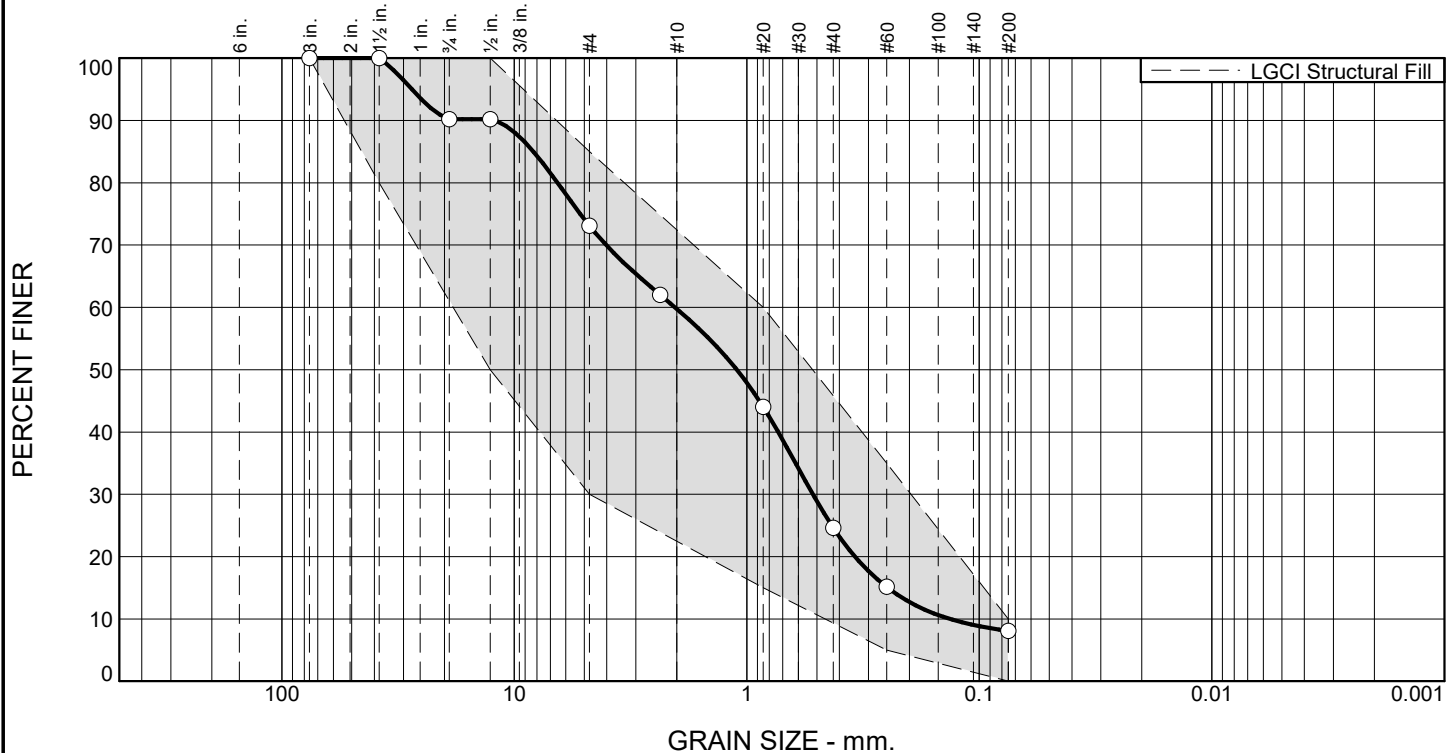

% +3"	% Gravel		% Sand			% Fines	
	Coarse	Fine	Coarse	Medium	Fine	Silt	Clay
0.0	9.8	17.1	13.3	35.2	16.5	8.1	

TEST RESULTS			
Opening Size	Percent Finer	Spec.* (Percent)	Pass? (X=Fail)
3"	100.0	100.0	
1.5"	100.0	80.0 - 100.0	
0.75"	90.2		
0.5"	90.2	50.0 - 100.0	
#4	73.1	30.0 - 85.0	
#8	62.0		
#20	44.0	15.0 - 60.0	
#40	24.6		
#60	15.1	5.0 - 35.0	
#200	8.1	0.0 - 10.0	

Material Description

ASTM (D 2488) Classification: Well Graded SAND with Silt and Gravel (SW-SM), fine to coarse, 5-10% fines, 25-30% fine subrounded gravel, light brown, dry

Atterberg Limits (ASTM D 4318)

PL= _____ LL= _____ PI= _____

Classification

USCS (D 2487)= _____ AASHTO (M 145)= _____

Coefficients

D₉₀= 12.0908 D₈₅= 8.2668 D₆₀= 2.0348
 D₅₀= 1.1036 D₃₀= 0.5200 D₁₅= 0.2472
 D₁₀= 0.1340 C_u= 15.18 C_c= 0.99

Remarks

Fill sample.

Date Received: 8/8/2019 Date Tested: 9/6/2019

Tested By: NP

Checked By: AML

* LGCI Structural Fill

Location: B-5 Sample Number: S3 Depth: 4'-6' Date Sampled: 8/8/2019



Client: Saccoccio & Associates, Inc.
 Project: Proposed Education Center and Event Pavillion
 Project No: 1911 Figure

5848-548 (802) 673-1234
University of Tennessee

APPROX.
EVENT PAULION

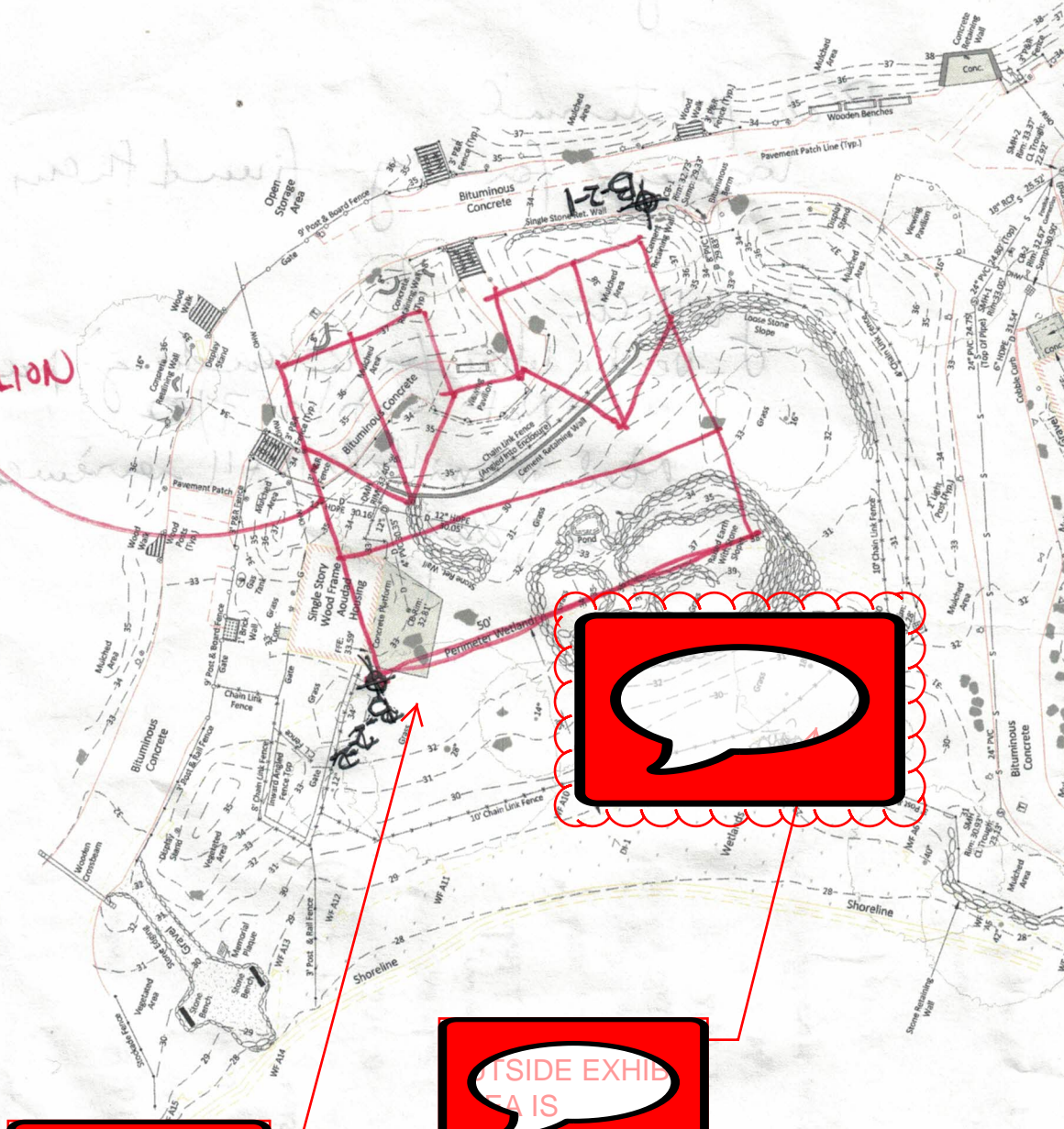

Drain Invert Table

DI-316	RIDE	28.39
DI-317	RIDE	29.39
DI-414	CP	29.39
DI-516	CP	29.39
DI-516	CONC	29.71
DI-516	CONC	29.68
DI-712	P.V.C	41.59

1161

ADVANCE UTILITY SITE PLANS

FOR:

ROGER WILLIAMS PARK ZOO EDUCATION CENTER & PAVILION

A.P. 90, LOT 1
1000 ELMWOOD AVENUE
PROVIDENCE, R.I. 02907

PREPARED FOR:

CITY OF PROVIDENCE

CITY HALL
PROVIDENCE, R.I. 02903

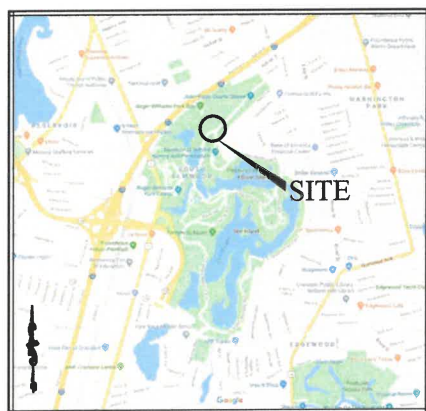

LOCUS MAP
NOT TO SCALE

DESIGN TEAM:



**Saccoccio &
Associates, Inc.**
1085 Park Avenue tel 401.942.7970
Cranston, Rhode Island fax 401.942.7975
02910



GAROFALO
GAROFALO & ASSOCIATES, INC.
CIVIL & STRUCTURAL ENGINEERS, SURVEYORS
LAND PLANNERS, ENVIRONMENTAL SCIENTISTS
P.O. BOX 6145 PROVIDENCE, R.I. 02940
1-401-273-6000

JOB NO.7213-00

DATED:
DECEMBER 16, 2022
(REVISED DATE:05-22-2023)

SHEET INDEX		
SHEET	PLAN TITLE	LATEST REVISION
-	COVER SHEET	
1.0	GENERAL NOTES AND LEGEND	
2.0	DEMOLITION PLAN	
3.0	SITE PREPARATION PLAN	05-22-2023
4.0	CONSTRUCTION DETAILS-1	

ISSUED FOR
CONSTRUCTION



GENERAL CONSTRUCTION NOTES:

- AN APPROVED SET OF PLANS AND ALL APPLICABLE PERMITS MUST BE AVAILABLE AT THE CONSTRUCTION SITE TRAILER AT ALL TIMES. DEVIATIONS OR CHANGES WILL NOT BE ALLOWED UNLESS BY WRITTEN APPROVAL FROM THE ENGINEER.
- SI TEWORK CONSTRUCTION SHALL NOT COMMENCE UNTIL ALL APPROVALS HAVE BEEN SECURED. REQUIRED PERMITS/APPROVALS FOR THE PROJECT INCLUDE BUT NOT LIMITED TO THE FOLLOWING: SITE PLAN APPROVAL BY THE CITY OF PROVIDENCE/ROGER WILLIAMS PARK ZOO.
- THE CONTRACTOR SHALL VERIFY THE PROPOSED LAYOUT WITH ITS RELATIONSHIP TO THE EXISTING SITE SURVEY. THE CONTRACTOR SHALL VERIFY ALL DIMENSIONS, SITE CONDITIONS AND MATERIAL SPECIFICATIONS AND SHALL NOTIFY THE OWNER AND ENGINEER OF ANY ERRORS, OMISSIONS OR DISCREPANCIES BEFORE COMMENCING, INSTALLING OR PROCEEDING WITH WORK.
- IT IS THE RESPONSIBILITY OF THE CONTRACTOR TO DETERMINE THE LOCATION OF ALL EXISTING UNDERGROUND UTILITIES AND TO TAKE WHATEVER NECESSARY MEASURES NEEDED TO PROVIDE FOR THEIR PROTECTION. THE ENGINEER HAS DILIGENTLY ATTEMPTED TO LOCATE AND INDICATE ALL EXISTING UNDERGROUND UTILITIES AND FACILITIES ON THE DRAWINGS; HOWEVER, THE INFORMATION SHOWN IS FOR THE CONTRACTOR'S CONVENIENCE ONLY. THE ENGINEER ASSUMES NO RESPONSIBILITY FOR THE LOCATIONS OF UTILITIES SHOWN OR NOT SHOWN. THE CONTRACTOR SHALL MAKE EXPLORATORY EXCAVATIONS AND LOCATE ANY EXISTING UTILITIES SUFFICIENTLY AHEAD OF CONSTRUCTION, VERIFY ALL DIMENSIONS, SITE CONDITIONS AND MATERIALS. THE CONTRACTOR MUST CONTACT THE LOCAL UTILITY COMPANIES FOR EXACT LOCATION OF UTILITIES PRIOR TO THE START OF ANY CONSTRUCTION AND SHALL NOTIFY THE ENGINEER OF ANY DISCREPANCIES BEFORE START OF ANY WORK. IT IS THE SOLE RESPONSIBILITY OF THE CONTRACTOR TO REPAIR AND REPLACE ANY AND ALL DAMAGE MADE TO UTILITIES BY THE CONTRACTOR.
- THE CONTRACTOR MUST NOTIFY OPERATORS WHO MAINTAIN UNDERGROUND UTILITIES IN THE AREA OF PROPOSED CONSTRUCTION, EXCAVATION OR BLASTING AT LEAST THREE WORKING DAYS, BUT NOT MORE THAN TEN WORKING DAYS PRIOR TO THE START OF ANY CONSTRUCTION, EXCAVATION OR BLASTING. ALL WATER, SEWER, GAS AND ALL OTHER UTILITIES MUST BE MAINTAINED AT ALL TIMES DURING CONSTRUCTION.
- METHODS AND MATERIALS USED IN THE CONSTRUCTION OF IMPROVEMENTS MUST CONFORM TO THE CITY OF PROVIDENCE CURRENT CONSTRUCTION STANDARDS AND SPECIFICATIONS AND THE STATE OF RHODE ISLAND DEPARTMENT OF TRANSPORTATION CONSTRUCTION SPECIFICATIONS.
- THE CONTRACTOR IS RESPONSIBLE FOR REPLACING ANY PAVEMENT, DRIVEWAYS, SIDEWALKS, WALL, CURBS, ETC. DAMAGED DURING CONSTRUCTION WITH MATCHING MATERIALS.
- THE CONTRACTOR AGREES THAT HE WILL ASSUME SOLE AND COMPLETE RESPONSIBILITY FOR THE PROJECT SITE CONDITIONS THROUGHOUT CONSTRUCTION, INCLUDING SAFETY OF ALL PERSONS AND PROPERTY. THIS REQUIREMENT WILL APPLY CONTINUOUSLY AND NOT BE LIMITED TO NORMAL WORKING HOURS AND THAT THE CONTRACTOR SHALL DEFEND, INDEMNIFY AND HOLD THE OWNER AND THE ENGINEER HARMLESS FROM ANY AND ALL LIABILITY, REAL OR ALLEGED IN CONJUNCTION WITH THE PERFORMANCE OF WORK ON THIS PROJECT.
- ALL MATERIALS USED FOR CONSTRUCTION MUST BE NEW AND FREE OF DEFECTS. USE OR SALVAGED MATERIAL WILL NOT BE ALLOWED UNLESS WRITTEN APPROVAL FROM THE OWNER IS OBTAINED BY THE CONTRACTOR.
- NECESSARY BARRICADES, LIGHTS, SIGNS AND OTHER TRAFFIC CONTROL METHODS AS MAYBE NECESSARY FOR THE PROTECTION AND SAFETY OF THE PUBLIC MUST BE PROVIDED AND MAINTAINED THROUGHOUT CONSTRUCTION BY THE CONTRACTOR.
- PRIOR TO THE START OF CONSTRUCTION THE CONTRACTOR IS REQUIRED TO DEVELOP AND IMPLEMENT A PLAN FOR THE TEMPORARY CONTROL OF VEHICULAR AND PEDESTRIAN TRAFFIC FOR WORK WITHIN PUBLIC STREET RIGHT-OF-WAY AT THE SITE EGRESS. CONTRACTOR SHALL OBTAIN APPROVAL OF SAID PLAN FROM APPROPRIATE STATE AND COMMUNITY PUBLIC SAFETY OFFICIALS.
- PRECAST STRUCTURES MAY BE USED AT CONTRACTOR'S OPTION. SHOP DRAWINGS OF PRECAST STRUCTURES SHALL BE REVIEWED BY THE ENGINEER AND APPROVED BEFORE USE.
- IF ANY EXISTING STRUCTURES AND/OR UTILITIES TO REMAIN ARE DAMAGED DURING CONSTRUCTION, EITHER ON THE PROJECT SITE, ADJACENT PROPERTIES, OR WITHIN STATE RIGHT-OF-WAY, IT SHALL BE THE CONTRACTOR'S RESPONSIBILITY TO REPAIR AND/OR REPLACE THE EXISTING STRUCTURE AS NECESSARY TO RETURN IT TO EXISTING CONDITIONS OR BETTER.

SURVEY REFERENCE:

- THE EXISTING CONDITIONS SHOWN WERE PROVIDED BY THE ROGER WILLIAMS PARK ZOO FOR USE IN THE PROJECT DESIGN AND ARE BASED ON DRAWINGS PREPARED BY BERKSHIRE DESIGN GROUP, ET. AL. THE EXISTING MAPPING HAS BEEN SUPPLEMENTED BY LIMITED FIELD "EDITS BY GAROFALO & ASSOCIATES, BASED ON OBSERVED CONDITIONS IN JULY 2019 AND RECORD PLANS FOR PAST CONSTRUCTION WITHIN AND ADJACENT TO THE WORK ZONE. FIELD SURVEY WAS PERFORMED BY GAROFALO & ASSOCIATES WITHIN THE ZEBRA EXHIBIT IN OCTOBER, 2019 TO SUPPLEMENT THE BASE MAPPING PROVIDED.
- THIS SURVEY HAS BEEN CONDUCTED AND THE PLAN HAS BEEN PREPARED PURSUANT TO SECTION 435-RICR-00-00-1.9 OF THE RULES AND REGULATIONS ADOPTED BY THE RHODE ISLAND BOARD OF REGISTRATION FOR PROFESSIONAL LAND SURVEYORS ON NOVEMBER 25, 2015, AS FOLLOWS
- | | |
|-----------------------------|-----------|
| DATA ACCUMULATION SURVEY | CLASS III |
| TOPOGRAPHIC SURVEY ACCURACY | T-2 |

GENERAL UTILITY NOTES:

- THE CONTRACTOR SHALL NOTIFY DIG-SAFE (1-888-344-7233) AND ALL LOCAL AUTHORITIES & UTILITY COMPANIES TO VERIFY LOCATIONS OF UTILITIES WITHIN THE AREA 72 HOURS PRIOR TO BEGINNING ANY EXCAVATION OR DEMOLITION FOR THE PURPOSE OF COORDINATING THE MARKING OF UNDERGROUND UTILITIES. LOCATION AND DEPTHS OF EXISTING UTILITIES SHOWN ARE APPROXIMATE ONLY. THE CONTRACTOR SHALL BE RESPONSIBLE TO VERIFY, LOCATE AND PROTECT EXISTING UTILITIES IN THE FIELD WHETHER OR NOT SHOWN ON THE DRAWINGS.
- ALL WORK SHALL BE IN COMPLETE ACCORDANCE WITH ALL APPLICABLE STATE, FEDERAL AND LOCAL CODES, AND ALL NECESSARY LICENSES AND PERMITS SHALL BE OBTAINED BY THE CONTRACTOR AT HIS EXPENSE UNLESS PREVIOUSLY OBTAINED BY THE OWNER/DEVELOPER.
- THE CONTRACTOR SHALL COORDINATE LOCATION AND INSTALLATION OF ALL UNDERGROUND UTILITIES AND APPURTENANCES TO MINIMIZE DISTURBANCE OF CURBING, PAVING AND COMPACTED SUBGRADE. THE CONTRACTOR SHALL NOTIFY THE TOWN ENGINEER & ALL LOCAL UTILITY COMPANIES 48 HOURS BEFORE EACH PHASE OF CONSTRUCTION. THE CONTRACTOR SHALL IMMEDIATELY INFORM THE ENGINEER OF ANY DISCREPANCIES OR ERRORS DISCOVERED IN THE PLANS.
- BEDDING REQUIREMENTS SPECIFIED HEREIN ARE TO BE CONSIDERED AS MINIMUMS FOR RELATIVELY DRY, STABLE EARTH CONDITIONS. ADDITIONAL BEDDING SHALL BE REQUIRED FOR ROCK TRENCHES AND WET AREA. CONTRACTOR SHALL HAVE THE RESPONSIBILITY TO PROVIDE SUCH ADDITIONAL BEDDING AS MAY BE REQUIRED TO PROPERLY CONSTRUCT THE WORK.
- THE CONTRACTOR SHALL REMOVE ANY ABANDONED FOUNDATIONS, UTILITY STRUCTURES, BURIED DEBRIS ETC. WHICH INTERFERE WITH THE INSTALLATION OF THE UTILITY WORK. ALL SUCH STRUCTURES SHALL BE COMPLETELY REMOVED AND THE EXCAVATED AREA SHALL BE BACKFILLED WITH COMPACTED GRAVEL IN 6" LIFTS TO 95% COMPACTION TO 6" BELOW THE BOTTOM OF THE UTILITY AND PIPE.
- COMPACTION OF THE BACKFILL OF ALL TRENCHES SHALL BE COMPACTION TO THE DENSITY OF 95% OF THE THEORETICAL MAXIMUM DRY DENSITY (ASTM D698). BACKFILL MATERIAL SHALL BE FREE FROM ROOTS, STUMPS OR OTHER FOREIGN DEBRIS AND SHALL BE PLACED IN LIFTS NOT TO EXCEED ONE FOOT IN COMPACTED FILL THICKNESS. CORRECTION OF ANY TRENCH SETTLEMENT WITHIN A YEAR FROM THE DATE OF PROJECT APPROVAL WILL BE THE RESPONSIBILITY OF THE CONTRACTOR.
- ALL PIPING LAYOUT INDICATED ON THESE PLANS IS DIAGRAMMATIC ONLY AND DOES NOT SHOW ALL THE REQUIRED FITTINGS FOR PROPER ALIGNMENT. THE CONTRACTOR SHALL PROVIDE ALL REQUIRED FITTINGS TO OBTAIN PROPER ALIGNMENT AND FOR EXISTING UTILITY CONNECTIONS BASED UPON FIELD CONDITIONS.
- IF DURING EXCAVATION THE TRENCH WIDTH EXCEEDS THE SUM OF THE PIPE O.D. PLUS 2"-0", PLACE AND COMPACT THE FILL TO 12" ABOVE THE PIPE AND RE-EXCAVATE TO REQUIRED GRADE.
- ALL WATER SERVICE MATERIALS AND WORKMANSHIP SHALL CONFORM TO PROVIDENCE WATER SUPPLY BOARD REGULATIONS, STANDARDS AND SPECIFICATIONS.
- SEWER LINES SHALL BE INSTALLED AT A MINIMUM 10 FOOT HORIZONTAL SEPARATION FROM ANY PROPOSED OR EXISTING WATER LINE. WHENEVER SEWER LINES MUST CROSS WATER LINES, THE SEWER SHALL BE INSTALLED SO THAT THE TOP OF THE SEWER IS AT LEAST 18 INCHES BELOW THE BOTTOM OF THE WATER MAIN. WHERE 18 INCH VERTICAL SEPARATION & 10 FOOT HORIZONTAL SEPARATION CAN NOT BE MET AT WATER AND SEWER CROSSINGS, THE SEWER PIPE SHALL BE ENCASED IN EITHER DUCTILE IRON OR C900 BLUE BRUTE PIPE FOR A DISTANCE OF 10 FEET ON EACH SIDE OF CROSSING.
- STORM DRAINS 12" AND OVER SHALL BE SMOOTH INTERIOR WALL AND EXTERIOR CORRUGATED HIGH DENSITY POLYETHYLENE (HDPE) PIPE CAPABLE OF WITHSTANDING (H=20) LOAD UNLESS NOTED OTHERWISE. PIPE SHALL BE JOINED USING BELL & SPIGOT JOINTS MEETING OR EXCEED ASTM F2648. THE JOINT SHALL BE SOIL-TIGHT AND GASKETS SHALL MEET OR EXCEED ASTM F477. HDPE PIPE SHALL BE AS MANUFACTURED BY ADVANCED DRAINAGE SYSTEMS INC. (ADS), HANCOCK PIPE OR LANE PIPE. ALL STORM DRAINAGE PIPING SHALL BE LAID ON A SMOOTH CONTINUOUS GRADE WITH NO VISIBLE BENDS AT THE JOINTS. WHERE INDICATED ON DRAWINGS REINFORCED CONCRETE PIPE (RCP) PIPE SHALL BE CLASS III RCP WITH "O" RING GASKET JOINTS
- GAS SERVICE FACILITIES SHALL BE DESIGNED BY OTHERS. CONTRACTOR SHALL BE RESPONSIBLE TO COORDINATE UTILITY INSTALLATIONS AS REQUIRED TO ENSURE ADEQUATE GAS SERVICE IS PROVIDED AND SHALL BE RESPONSIBLE FOR ALL INSTALLATION PROCEDURES (TRENCHING, LAYING PIPE, ETC.) AS ARE REQUIRED BY THE GAS COMPANY FOR COMPLETE AND IN PLACE CONSTRUCTION.
- ELECTRIC SERVICE FACILITIES SHALL BE DESIGNED BY OTHERS. ELECTRIC SERVICE AND TRANSFORMER PAD SHALL CONFORM TO THE REQUIREMENTS OF THE ELECTRIC COMPANY. CONTRACTOR SHALL BE RESPONSIBLE FOR ENSURING ADEQUATE ELECTRIC SERVICE IS PROVIDED AND SHALL BE RESPONSIBLE FOR ALL INSTALLATION PROCEDURES (TRENCHING, LAYING PIPE, ETC.) AS ARE REQUIRED BY THE ELECTRIC COMPANY FOR COMPLETE AND IN PLACE CONSTRUCTION. REFER TO ELECTRICAL DRAWINGS FOR DETAILS ON ALL UNDERGROUND ELECTRIC.
- TEL/CABLE SERVICE FACILITIES SHALL BE DESIGNED BY OTHERS. CONTRACTOR SHALL BE RESPONSIBLE FOR ENSURING ADEQUATE UTILITY SERVICE IS PROVIDED AND SHALL BE RESPONSIBLE FOR ALL INSTALLATION PROCEDURES (TRENCHING, LAYING PIPE ETC.) AS IS REQUIRED BY THE LOCAL UTILITY CO. FOR COMPLETE AND IN PLACE CONSTRUCTION. REFER TO ELECTRICAL DRAWINGS FOR ALL UNDERGROUND ELECTRIC.

GENERAL DRAINAGE & GRADING NOTES:

- ALL STORM PIPE ENTERING STRUCTURES SHALL BE GROUTED TO ASSURE CONNECTION AT STRUCTURE IS WATERTIGHT.
- ALL STORM SEWER MANHOLES IN PAVED AREAS SHALL BE FLUSH WITH PAVEMENT, AND SHALL HAVE TRAFFIC BEARING RING & COVERS. MANHOLES IN UNPAVED AREAS SHALL BE 6" ABOVE FINISH GRADE. LIDS SHALL BE LABELED "STORM SEWER".
- CONTRACTOR SHALL ADJUST AND/OR CUT EXISTING PAVEMENT AS NECESSARY TO ASSURE A SMOOTH FIT AND CONTINUOUS GRADE.
- CONTRACTOR SHALL ASSURE POSITIVE DRAINAGE AWAY FROM BUILDINGS FOR ALL NATURAL AND PAVED AREAS.
- ALL UNSURFACED AREAS DISTURBED BY GRADING OPERATION SHALL RECEIVE 4 INCHES OF TOPSOIL. CONTRACTOR SHALL APPLY STABILIZATION FABRIC AT ALL SLOPES 3H:1V OR STEEPER. CONTRACTOR SHALL GRASS DISTURBED AREAS IN ACCORDANCE WITH THE CITY OF PROVIDENCE SPECIFICATIONS UNTIL A HEALTHY STAND OF GRASS IS OBTAINED.
- INSTALL SILT SACKS AT ALL INLETS AFTER INSTALLATION.

SEQUENCE AND STAGING OF LAND

DISTURBING ACTIVITIES:

- SURVEY AND STAKE THE DRAINAGE STRUCTURES, LIMIT OF WORK AND SEDIMENTATION BARRIERS.
- PLACE SEDIMENTATION BARRIERS (SILT SOCK OR SILT FENCE) AS SHOWN ON THE PLANS AND STAKED OUT IN THE FIELD. LIMIT OF WORK IS NEVER TO EXTEND BEYOND THE SEDIMENTATION BARRIERS.
- BEGIN ROADWAY AND DRAINAGE WORK (CLEARING AND GRUBBING, EXCAVATING AND GRADING, ETC.). TOP SOIL TO BE STRIPPED AND STOCKPILED IN APPROVED AREAS. THE STOCKPILES ARE TO BE PROTECTED BY A ROW OF SEDIMENTATION BARRIER AND COVERED OR TEMPORARILY SEEDED. NO RUNOFF TO BE DISCHARGED TO THE DETENTION STRUCTURES UNTIL THE BINDER COURSE OF PAVEMENT IS INSTALLED AND DISTURBED AREAS ARE STABILIZED.
- BEGIN CLEARING WITHIN AREAS OF THE PROPOSED STRUCTURES FOLLOWING CONSTRUCTION OF ROADWAY.
- ALL PROPOSED CATCH BASINS MUST BE LINED WITH SILT SACKS IMMEDIATELY AFTER INSTALLATION.
- SWEEP THE ROADWAY AREAS TO REMOVE ALL SEDIMENTS.
- FLUSH AND/OR REPAIR DRAINAGE AREAS AS NEEDED.
- REMOVE ALL TEMPORARY SESS MEASURES FOLLOWING VEGETATIVE ESTABLISHMENT OF ALL DISTURBED AREAS.

SEDIMENTATION CONTROL PROGRAM:

- EXTREME CARE SHALL BE EXERCISED TO PREVENT ANY SEDIMENTS FROM ENTERING THE ADJOINING PROPERTIES.
- BANKS OR SLOPES OVER 5% SHALL BE SEEDED AS SOON AS POSSIBLE AND BE PROTECTED WITH STRAW OR FIBER MULCH.
- DURING CONSTRUCTION, THE CONTRACTOR AND/OR DEVELOPER SHALL BE RESPONSIBLE FOR MAINTAINING DRAINAGE AND RUNOFF FLOW DURING STORMS AND PERIODS OF RAINFALL.
- SEDIMENTATION CONTROL DEVICES SHALL BE INSPECTED CLOSELY AND MAINTAINED PROMPTLY AFTER EACH RAINFALL.
- CARE SHALL BE TAKEN SO AS NOT TO PLACE "REMOVED SEDIMENTS" WITHIN THE PATH OF EXISTING, NEWLY CREATED (BOTH TEMPORARY AND PERMANENT) OR PROPOSED WATERCOURSES OR THOSE AREAS SUBJECTED TO STORM WATER FLOW.
- ADDITIONAL SILT SOCKS AND/OR SILT FENCE SHALL BE LOCATED AS CONDITIONS WARRANT OR AS DIRECTED BY THE ENGINEER.

EROSION CONTROL and SOIL STABILIZATION PROGRAM:

- DENUDED SLOPES SHALL NOT BE LEFT EXPOSED FOR EXCESSIVE PERIODS OF TIME.
 - ALL DISTURBED SLOPES EITHER NEWLY CREATED OR EXPOSED PRIOR TO OCTOBER 15, SHALL BE SEEDED OR PROTECTED BY THAT DATE FOR ANY WORK COMPLETED DURING EACH CONSTRUCTION YEAR.
 - TEMPORARY TREATMENTS SHALL CONSIST OF A HAY, STRAW, OR FIBER MULCH OR PROTECTIVE COVERS SUCH AS A MAT OR FIBER LINING (BURLAP, JUTE, FIBERGLASS NETTING, EXCELSIOR BLANKETS). THEY SHALL BE INCORPORATED INTO THE WORK AS WARRANTED OR AS ORDERED BY THE ENGINEER.
 - HAY OR STRAW APPLICATIONS SHOULD BE IN THE AMOUNT OF 2000 LBS/ACRE.
 - ALL TEMPORARY PROTECTION SHALL REMAIN IN PLACE UNTIL AN ACCEPTABLE STAND OF GRASS OR APPROVED GROUND COVER IS ESTABLISHED.
 - THE TOPSOIL SHALL HAVE A SANDY LOAM TEXTURE RELATIVELY FREE OF SUBSOIL MATERIAL, STONES, ROOTS, LUMPS OF SOIL, TREE LIMBS, TRASH OR CONSTRUCTION DEBRIS.
 - THE SEED MIX SHALL BE INOCULATED WITHIN TWENTY FOUR (24) HOURS, BEFORE MIXING AND PLANTING, WITH APPROPRIATE INOCULUM FOR EACH VARIETY.
 - THE DESIGN MIX FOR TEMPORARY EROSION CONTROL AND SOIL STABILIZATION:
- | TYPE | % BY WEIGHT |
|---------------------|-------------|
| CREeping RED FESCUE | 70 |
| ASTORIA BENTGRASS | 5 |
| BIRDSFOOT TREEFOAL | 15 |
| PERENNIAL RYEGRASS | 10 |
- APPLICATION RATE 100 LBS/ACRE
- LIMING AND FERTILIZE AS REQUIRED TO COMPLIMENT OR UPGRADE EXISTING CONDITIONS.
- THE CONTRACTOR MUST REPAIR AND/OR RESEED ANY AREAS THAT DO NOT DEVELOP WITHIN THE PERIOD OF ONE (1) YEAR, AND HE SHALL DO SO AT NO ADDITIONAL EXPENSE.
 - ACCEPTABLE SEASONAL SEEDING DATES ARE APRIL 1ST THROUGH OCTOBER 15TH.
 - STABILIZATION OF ONE FORM OR ANOTHER AS DESCRIBED ABOVE SHALL BE ACHIEVED WITHIN FIFTEEN (15) DAYS OF FINAL GRADING.
 - STOCKPILES OF TOPSOIL SHALL NOT BE LOCATED NEAR WATERWAYS OR FLOOD PLAINS. THEY SHALL HAVE SIDE SLOPES NO GREATER THAN THIRTY PERCENT (30%) AND STOCKPILES SHALL ALSO BE SEEDED AND/OR STABILIZED AND COMPLETELY ENCIRCLED WITH A CONTINUOUS LINE OF STAKED HAYBALES AND/OR SILTFENCE. (SEE DETAIL)
 - ON BOTH STEEP AND LONG SLOPES, CONSIDERATION SHOULD BE GIVEN TO "CRIMPING" OR "TRACKING" TO TACK DOWN MULCH APPLICATIONS.

SITE LEGEND

EXISTING	NEW	DESCRIPTION
---	---	CENTERLINE (LAYOUT)
---	---	STORM DRAIN
---	---	ELECTRIC (UNDERGROUND)
---	---	FIRE SERVICE
---	---	FOOTING DRAIN
---	---	GAS
---	---	OVERHEAD WIRE
---	---	PROPERTY LINE
---	---	SANITARY SEWER
---	---	SITE LIGHTING SERVICE
---	---	TELEPHONE
---	---	WATER
---	---	CONTOUR
x 64.0	x 64.00	SPOT GRADE
x 64.0(BC)	x 64.00(BC)	SPOT GRADE (BOT. OF CURB)
x 64.5(TC)	x 64.50(TC)	SPOT GRADE (TOP OF CURB)
64.5(BW)	64.50(BW)	SPOT GRADE (BOT. OF WALL)
64.5(TW)	64.50(TW)	SPOT GRADE (TOP OF WALL)
---	---	BITUMINOUS CONC. CURB
---	---	CAPE COD BERM
---	---	PRECAST CONC. CURB
---	---	PRECAST SLOPED MOUNT. CURB
---	---	SLOPED GRANITE CURB
---	---	VERTICAL GRANITE CURB
---	---	CHAINLINK FENCE (CLF)
---	---	STOCKADE FENCE (STKF)
---	---	BORING LOCATION
---	---	CATCH BASIN
---	---	DOUBLE GRATE CATCH BASIN
---	---	CONCRETE THRUST BLOCK
---	---	DRAIN MANHOLE
---	---	FLARED END STRUCTURE
---	---	SEWER MANHOLE
---	---	WATER SERVICE
---	---	UTILITY POLE
---	---	FIRE HYDRANT
---	---	GATE VALVE AND CURB BOX
---	---	HANDICAP SYMBOL (PRKG. SPACE)
---	---	SIGN
---	---	WETLAND
---	---	SOIL EVALUATION LOCATION
---	---	TEST PIT LOCATION
---	---	FIRE DEPARTMENT CONNECTION
---	---	POST INDICATOR VALVE (PIV)
---	---	ELECTRIC MANHOLE (EMH)
---	---	TELEPHONE MANHOLE (TMH)
---	---	TRANSFORMER PAD
---	---	GENERATOR PAD
---	---	GROUND CLEANOUT
---	---	SIGHT LIGHT POLE
---	---	TRAFFIC FLOW DIRECTION
---	---	CONTINUOUS ROW OF HAYBALES
---	---	RIDOT/PROVIDENCE STD DETAIL REFERENCE

ABBREVIATIONS

CI	CAST IRON PIPE
CLDI	CEMENT LINED DUCTILE IRON PIPE
CLF	CHAINLINK FENCE
CTE	POINT OF CONNECTION TO EXISTING
D.I.	DUCTILE IRON PIPE
ESHWT	ESTIMATED SEASONAL HIGH WATER TABLE
ETR	EXISTING TO REMAIN
EX	EXISTING
F&I	FURNISH AND INSTALL
HDPE	HIGH DENSITY POLYETHYLENE PIPE
INV.	INVERT ELEVATION
MTE	MATCH TO EXISTING
NIC	NOT IN CONTRACT
NTS	NOT TO SCALE
PVC	POLYVINYL CHLORIDE PIPE
RCF	REINFORCED CONCRETE PIPE
VP	VERIFY IN FIELD
WQS	WATER QUALITY STRUCTURE



Saccoccio & Associates, Inc.

1085 Park Avenue
Cranston, Rhode Island 02910
tel 401.942.7970
fax 401.942.7975

Consultant



GAROFALO & ASSOCIATES, INC.
CIVIL & STRUCTURAL ENGINEERS/SURVEYORS
LAND PLANNERS/ENVIRONMENTAL SCIENTISTS
P.O. BOX 6145 PROVIDENCE, R.I. 02940
1-401-273-6000

**Education Center & Pavilion
Advance Utility
Site Plans**

1000 Elmwood Avenue
Providence, RI 02907

**Roger Williams
Park Zoo**

ISSUED FOR CONSTRUCTION

Revision Schedule	
Revision Number	Revision Date

**SHEET TITLE
GENERAL
NOTES & LEGEND**

DRAWN BY: KYK JOB NUMBER: 7213-00

CHECKED BY: SSH DATE: 12/16/2022

1.0

SHEET: 2 OF: 5

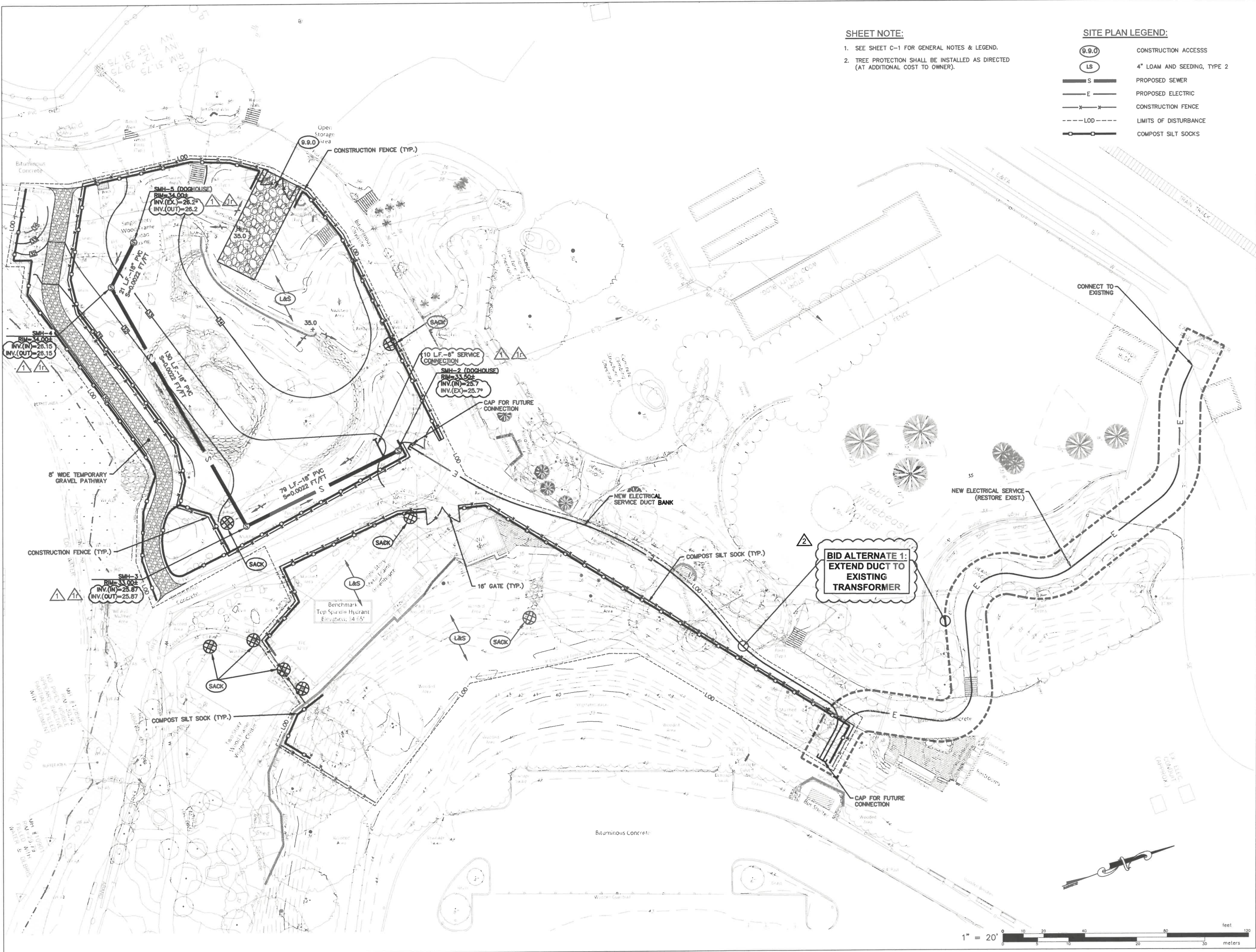

SHEET NOTE:

- SEE SHEET C-1 FOR GENERAL NOTES & LEGEND.
- TREE PROTECTION SHALL BE INSTALLED AS DIRECTED (AT ADDITIONAL COST TO OWNER).

SITE PLAN LEGEND:

- CONSTRUCTION ACCESS
- 4" LOAM AND SEEDING, TYPE 2
- PROPOSED SEWER
- PROPOSED ELECTRIC
- CONSTRUCTION FENCE
- LIMITS OF DISTURBANCE
- COMPOST SILT SOCKS



Saccoccio & Associates, Inc.
 1085 Park Avenue
 Cranston, Rhode Island 02910
 tel 401.942.7970
 fax 401.942.7975

Consultant



GAROFALO & ASSOCIATES, INC.
 CIVIL & STRUCTURAL ENGINEERS/SURVEYORS
 LAND PLANNERS/ENVIRONMENTAL SCIENTISTS
 P.O. BOX 6145 PROVIDENCE, R.I. 02940
 1-401-273-6090

Education Center & Pavilion Advance Utility Site Plans

1000 Elmwood Avenue
 Providence, RI 02907

Roger Williams Park Zoo

ISSUED FOR CONSTRUCTION

Revision Schedule	
Revision Number	Revision Date
1	01-12-2023
1r	01-18-2023
2	05-22-2023

SHEET TITLE
SITE PREPARATION PLAN

DRAWN BY: KYY JOB NUMBER: 7213-00
 CHECKED BY: SSH DATE: 12/16/2022

3.0

SHEET: 4 OF: 5

L:\7213-00 Roger Williams Park Zoo (Saccoccio) - Providence, RI\dwg\01-Current\OFFSITE UTIL\DWG\7213-00-01_BUSE.dwg 05/22/2023 kyympng 15:40



Saccocio & Associates, Inc.
 1085 Park Avenue
 Cranston, Rhode Island 02910
 tel 401.942.7970
 fax 401.942.7975

GAROFALO
 GAROFALO & ASSOCIATES, INC.
 CIVIL & STRUCTURAL ENGINEERS/SURVEYORS
 LAND PLANNERS/ENVIRONMENTAL SCIENTISTS
 P.O. BOX 6145 PROVIDENCE, R.I. 02940
 1-401-273-6000

**Education Center & Pavilion
 Advance Utility
 Site Plans**

1000 Elmwood Avenue
 Providence, RI 02907

**Roger Williams
 Park Zoo**

ISSUED FOR CONSTRUCTION

Revision Schedule	
Revision Number	Revision Date

SHEET TITLE
DETAILS PLAN

DRAWN BY: KYY JOB NUMBER: 7213-00
 CHECKED BY: SSH DATE: 12/16/2022

4.0

SHEET: 5 OF: 5

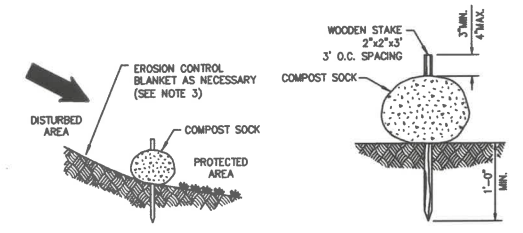

- NOTES:**
1. COMPOST SOCK SHALL BE INSTALLED PER MANUFACTURERS RECOMMENDATIONS. COMPOST SOCK SHALL BE A MINIMUM OF 8" IN DIAMETER.
 2. COMPOST MATERIAL TO BE DISPERSED ON SITE, AS DETERMINED BY THE ENGINEER.
 3. WHEN PLACING COMPOST SOCK ON SLOPES, USE EROSION CONTROL BLANKET IF SPECIFIED ON PLANS.
 4. ALWAYS INSTALL COMPOST SOCK PERPENDICULAR TO SLOPE AND ALONG CONTOUR LINES.
 5. REMOVE SEDIMENT FROM THE UP SLOPE SIDE OF THE COMPOST SOCK WHEN ACCUMULATION HAS REACHED 1/2 OF THE EFFECTIVE HEIGHT OF THE COMPOST SOCK.
 6. NO STAKES ARE REQUIRED WHERE COMPOST SOCK IS INSTALLED ON PAVEMENT.

COMPOST SILT SOCK
 NOT TO SCALE

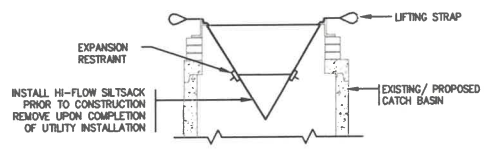

SILTSACK® AT CATCH BASIN
 NOT TO SCALE

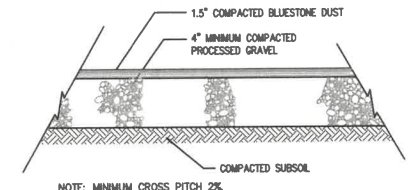

GRAVEL PATHWAY
 NOT TO SCALE

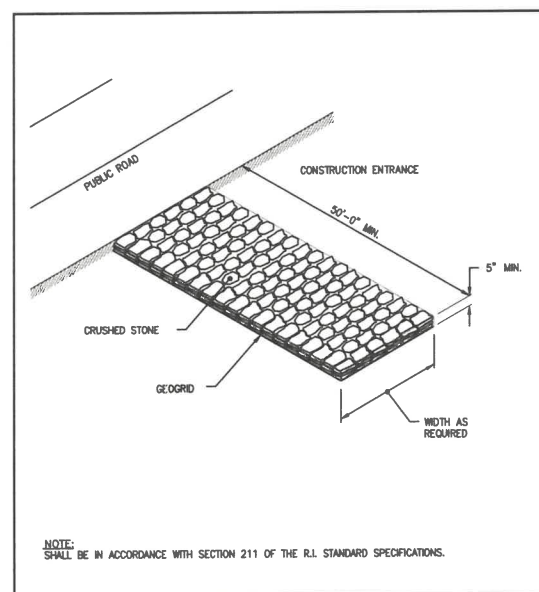

CONSTRUCTION ACCESS
 NOT TO SCALE

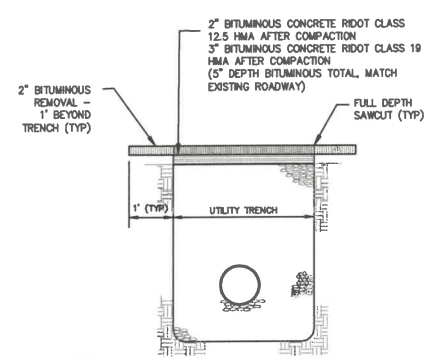

- NOTE:**
 FOLLOWING SETTLING OF PAVEMENT WITHIN THE UTILITY TRENCHES, THE CONTRACTOR SHALL REMOVE 2" BITUMINOUS ACROSS ENTIRE TRENCH WORK ZONE (AND 1' BEYOND TRENCHES) AND REPLACE WITH 2" BITUMINOUS CONCRETE, CLASS 12.5.

TRENCH RESURFACING
 NOT TO SCALE

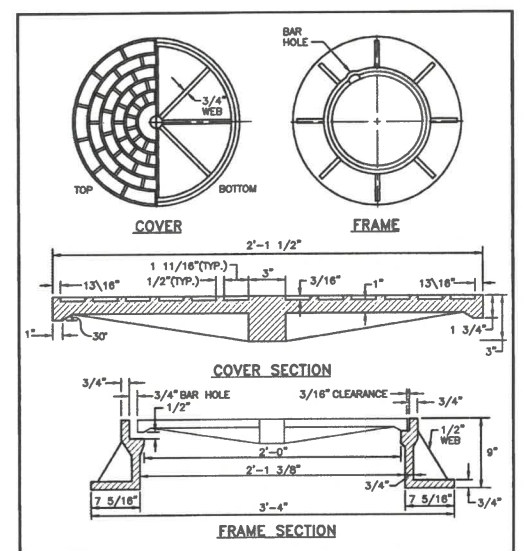

**RHODE ISLAND DEPARTMENT OF TRANSPORTATION
 HEAVY-DUTY
 ROUND FRAME AND COVER
 R.I. STANDARD 6.2.1**

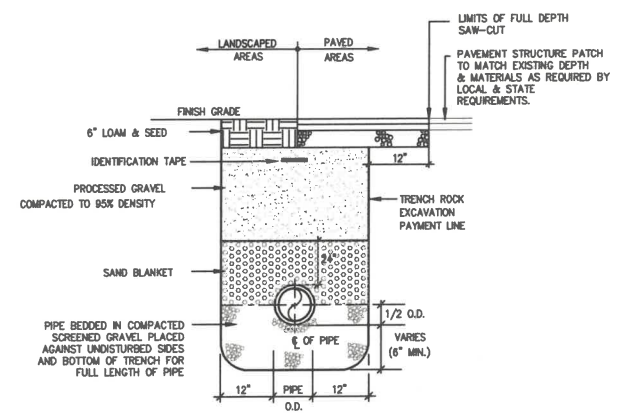

- NOTES:**
 METALIZED 2" WIDE DETECTABLE IDENTIFICATION TAPE SHALL BE INSTALLED OVER SEWER LINES 12" BELOW FINISH GRADE.
 MINIMUM DEPTH OF COVER SHALL BE 5'-0"

TRENCH SECTION (SEWER)
 NOT TO SCALE

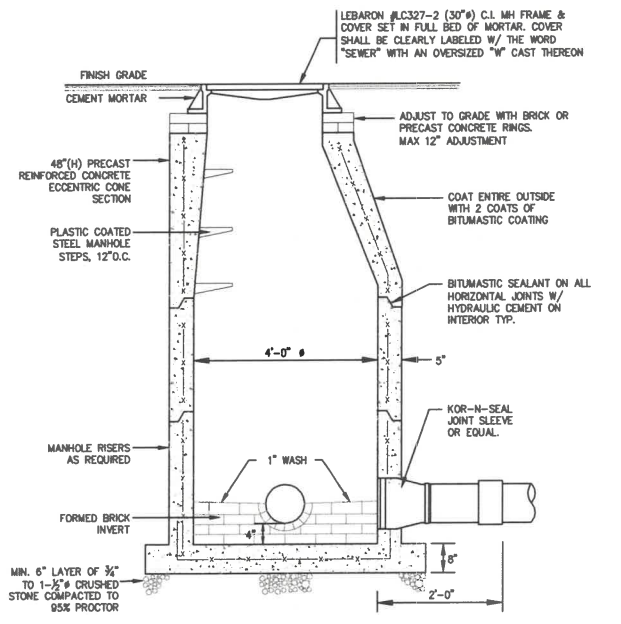

- NOTE:**
 ALL LIFTING HOLES TO BE PLUGGED IN AND OUT WITH HYDRAULIC CEMENT.

SANITARY SEWER MANHOLE
 NOT TO SCALE

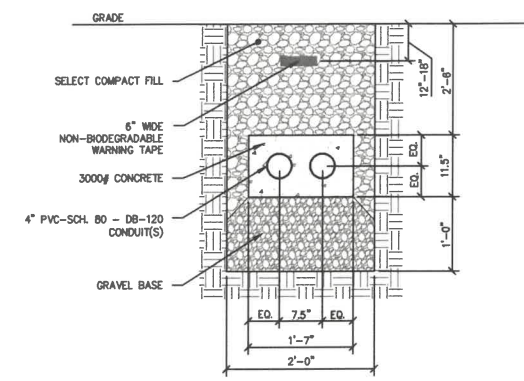

DUCT BANK
 NOT TO SCALE

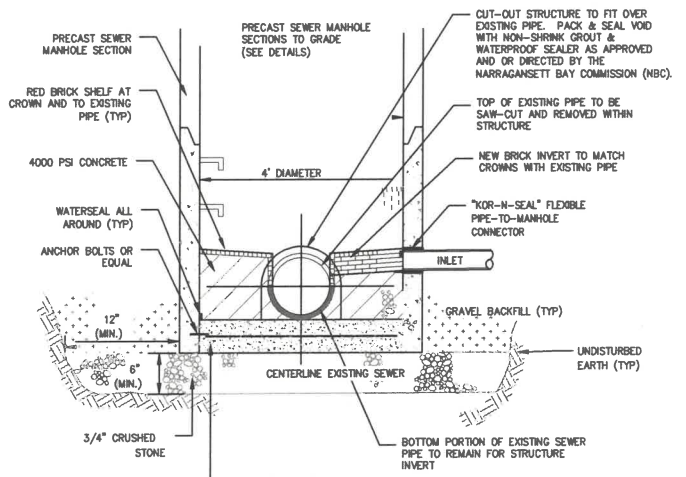

- NOTES:**
1. MANHOLE CONSTRUCTION SHALL CONFORM TO LATEST ASTM C478 SPECIFICATION FOR "PRECAST REINFORCED CONCRETE MANHOLE SECTIONS AND THE RI STANDARD DETAILS.
 2. SERVICE SHALL BE MAINTAINED WITHIN EXISTING MAN THROUGHOUT CONSTRUCTION.

SANITARY SEWER "DOG HOUSE" MANHOLE
 NOT TO SCALE

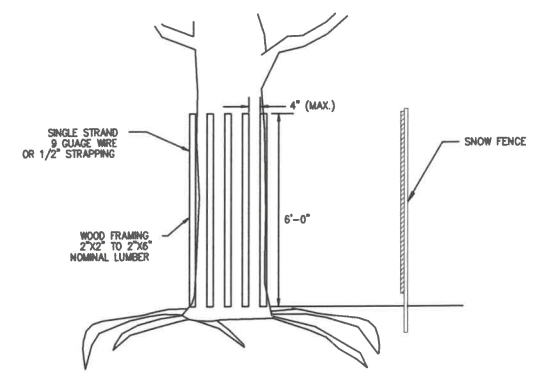

TREE PROTECTION
 NOT TO SCALE

L:\7213-00 Roger Williams Park Zoo (Saccocio) - Providence, RI\dwg\01-Current\OFFSITE UTIL DWG\7213-00-DU-BASE.dwg 05/22/2023 kymingyong 15:11

THIS PAGE INTENTIONALLY LEFT BLANK

SECTION 01 20 00

PRICE AND PAYMENT PROCEDURES

PART 1 - GENERAL

1.01 SECTION INCLUDES

- A. Schedule of values.
- B. Applications for payment.
- C. Sales Tax Exemption
- D. Change procedures.
- E. Defect assessment.
- F. Unit prices.

1.02 SCHEDULE OF VALUES

- A. Submit a printed schedule on AIA Form G703 - Application and Certificate for Payment Continuation Sheet
- B. Submit Schedule of Values in duplicate, one copyrighted original and one copy, within fifteen (15) days after date of receipt of a Notice to Proceed.
- C. Format: Utilize the Table of Contents of this Project Manual. Identify each line item with number and title of the major specification Section. Identify site mobilization, bonds and insurance.
- D. Include in each line item, the amount of Allowances specified in Section 01 21 00 if occurring. For unit cost Allowances, identify quantities taken from Contract Documents multiplied by the unit cost to achieve the total for the item.
- E. Include separately from each line item, a direct proportional amount of Contractor's overhead and profit.
- F. Revise schedule to list approved Change Orders, with each Application for Payment.

1.03 APPLICATIONS FOR PAYMENT

- A. Submit each application on an original copyrighted AIA Form G702 - Application and Certificate for Payment and AIA G703 - Continuation Sheet, accompanied by three copies.
 - 1. Individually sign and notarize, and emboss with notary's official seal, the original and each of the three copies.
 - 2. Applications not including original copyrighted AIA G702, and G703 Forms, will be rejected, and returned for resubmittal.
 - 3. Applications not properly signed and notarized will be rejected, and returned for resubmittal.

- B. Content and Format: Utilize Schedule of Values for listing items in Application for Payment.
- C. Provide one copy of the updated construction schedule with each Application for Payment submission.
 - 1. Provide a statement signed by the Contractor's firm principal certifying that there are no unidentified outstanding claims for delay.
- D. Include with each monthly Application for Payment, following the first application, one copy of the Certified Monthly Payroll Record for the previous month's pay period.
- E. Payment Period: Submit at intervals stipulated in the Agreement.
- F. Submit with transmittal letter as specified for Submittals in Section 01 33 00.
- G. Beginning with the second Application for Payment, Contractor's right to payment must be substantiated by documenting, on a copy of the Waiver of Lien Form included in Document 00 65 19.16 - Waiver of Lien Form in this Project Manual, that payment monies due, less retainage not exceeding ten percent, have been paid in full to subcontractor and suppliers for work, materials, or rental of equipment billed for under specific line item numbers in the immediately preceding application.
- H. Substantiating Data: When the Architect requires substantiating information, submit data justifying dollar amounts in question. Include the following with the Application for Payment :
 - 1. Record Documents as specified in Section 01 78 00, for review by the Owner which will be returned to the Contractor.
 - 2. Affidavits attesting to off-site stored products.
 - 3. Construction progress schedules, revised and current as specified in Section 01 33 00.

1.04 SALES TAX EXEMPTION

- A. Owner is exempt from sales tax on products permanently incorporated in Work of the Project.
 - 1. Obtain sales tax exemption certificate number from Owner.
 - 2. Place exemption certificate number on invoice for materials incorporated in the Work of the Project.
 - 3. Furnish copies of invoices to Owner.
 - 4. Upon completion of Work, file a notarized statement with Owner that all purchases made under exemption certificate were entitled to be exempt.
 - 5. Pay legally assessed penalties for improper use of exemption certificate number.

1.05 CHANGE PROCEDURES

- A. Submittals: Submit name of the individual authorized to receive change documents, and be responsible for informing others in Contractor's employ or Subcontractors of changes to the Work.
- B. The Architect will advise of minor changes in the Work not involving an adjustment to Contract Sum or Contract Time by issuing supplemental instructions on AIA Form G710
- C. The Architect may issue a Proposal Request which includes a detailed description of a proposed change with supplementary or revised Drawings and specifications, a change in Contract Time for executing the change with a stipulation of any overtime work required and the period of time

during which the requested price will be considered valid. Contractor will prepare and submit an estimate within fifteen (15) days.

- D. The Contractor may propose changes by submitting a request for change to the Architect, describing the proposed change and its full effect on the Work. Include a statement describing the reason for the change, and the effect on the Contract Sum and Contract Time with full documentation, and a statement describing the effect on Work by separate or other Contractors. Document any requested substitutions in accordance with Section 01 60 00.
- E. Stipulated Sum Change Order: Based on Proposal Request, and Contractor's fixed price quotation, or Contractor's request for a Change Order as approved by Architect.
- F. Unit Price Change Order: For contract unit prices and quantities, the Change Order will be executed on a fixed unit price basis. For unit costs or quantities of units of work that are not pre-determined, execute the Work under a Construction Change Directive. Changes in the Contract Sum or Contract Time will be computed as specified for a Time and Material Change Order.
- G. Construction Change Directive: Architect may issue a directive, on AIA Form G713 Construction Change Directive signed by the Owner, instructing the Contractor to proceed with a change in the Work, for subsequent inclusion in a Change Order. Document will describe changes in the Work, and designate method of determining any change in the Contract Sum or Contract Time. Promptly execute the change.
- H. Time and Material Change Order: Submit an itemized account and supporting data after completion of the change, within the time limits indicated in the Conditions of the Contract. The Architect will determine the change allowable in the Contract Sum and Contract Time as provided in the Contract Documents.
- I. Maintain detailed records of work done on a Time and Material basis. Provide full information required for an evaluation of the proposed changes, and to substantiate costs for the changes in the Work.
- J. Document each quotation for a change in cost or time with sufficient data to allow an evaluation of the quotation. Provide detailed breakdown of costs and estimates for labor and materials including a detailed breakdown for subcontractor's or vendor's Work. Include copies of written quotations from subcontractors or vendors.
- K. Change Order Forms: AIA G701 Change Order.
- L. Execution of Change Orders: The Architect will issue Change Orders for signatures of the parties as provided in the Conditions of the Contract.
- M. Correlation Of Contractor Submittals:
 - 1. Promptly revise the Schedule of Values and the Application for Payment forms to record each authorized Change Order as a separate line item and adjust the Contract Sum.
 - 2. Promptly revise progress schedules to reflect any change in the Contract Time, revise sub-schedules to adjust times for any other items of work affected by the change, and resubmit.
 - 3. Promptly enter changes in the Project Record Documents.

1.06 DEFECT ASSESSMENT

- A. Replace the Work, or portions of the Work, not conforming to specified requirements.
- B. If, in the opinion of the Architect, it is not practical to remove and replace the Work, the Architect will direct an appropriate remedy or adjust payment.
- C. The defective Work may remain, but the unit sum will be adjusted to a new sum at the discretion of the Architect.
- D. The defective Work will be partially repaired to the instructions of the Architect, and the unit sum will be adjusted to a new sum at the discretion of the Architect.
- E. The individual Specification Sections may modify these options or may identify a specific formula or percentage sum reduction.
- F. The authority of the Architect to assess the defect and identify a payment adjustment is final.
- G. Non-Payment for Rejected Products: Payment will not be made for rejected products for any of the following:
 - 1. Products wasted or disposed of in a manner that is not acceptable.
 - 2. Products determined as unacceptable before or after placement.
 - 3. Products not completely unloaded from the transporting vehicle.
 - 4. Products placed beyond the lines and levels of the required Work.
 - 5. Products remaining on hand after completion of the Work.
 - 6. Loading, hauling, and disposing of rejected products.

1.07 UNIT PRICES

- A. Authority: Measurement methods are delineated in the individual specification Sections.
- B. Measurement methods delineated in the individual specification Sections complement the criteria of this section. In case of conflict, the requirements of the individual specification Section govern.
- C. Take measurements and compute quantities. The Architect will verify measurements and quantities.
- D. Unit Quantities: The quantities and measurements indicated in the Bid Form are for contract purposes only. The quantities and measurements supplied or placed in the Work shall determine payment.
 - 1. When the actual Work requires more or fewer quantities than those quantities indicated, provide the required quantities at the unit sum contracted.
 - 2. When the actual Work requires a 25 percent or greater change in quantity than those quantities indicated, the Owner or Contractor may claim for a Contract Price adjustment.
- E. Unit Price amount includes: Full compensation for required labor, products, tools, equipment, plant and facilities, transportation, services and incidentals; erection, application or installation of an item of the Work; overhead and profit.

- F. Final payment for Work governed by unit prices will be made on the basis of the actual measurements and quantities accepted by the Architect multiplied by the unit sum for Work which is incorporated in or made necessary by the Work.
- G. Measurement of Quantities:
1. Weigh Scales: Inspected, tested and certified by the applicable state Weights and Measures department within the past year.
 2. Platform Scales: Of sufficient size and capacity to accommodate the conveying vehicle.
 3. Metering Devices: Inspected, tested and certified by the applicable State department within the past year.
 4. Measurement by Weight: Concrete reinforcing steel, rolled or formed steel or other metal shapes will be measured by handbook weights. Welded assemblies will be measured by handbook or scale weight.
 5. Measurement by Volume: Measured by cubic dimension using mean length, width and height or thickness.
 6. Measurement by Area: Measured by square dimension using mean length and width or radius.
 7. Linear Measurement: Measured by linear dimension, at the item centerline or mean chord.
 8. Stipulated Sum Measurement: Items measured by weight, volume, area, or linear means or combination, as appropriate, as a completed item or unit of the Work.
- H. See Bid Form for schedule of Unit Prices.

PART 2 - PRODUCTS

Not Used.

PART 3 - EXECUTION

Not Used.

END OF SECTION

THIS PAGE INTENTIONALLY LEFT BLANK

SECTION 01 21 00

ALLOWANCES

PART 1 - GENERAL

1.01 SECTION INCLUDES

- A. Cash allowances.
- B. Testing and inspection allowances.

1.02 CASH ALLOWANCES

- A. Costs Included in Cash Allowances: Cost of product to Contractor or Subcontractor, labor for installation and finishing, less applicable trade discounts; delivery to site, and applicable taxes
- B. Costs Not Included in Cash Allowances but included in the Contract Sum: Product delivery to site and handling at the site, including unloading, uncrating, and storage; protection of products from elements and from damage, Overhead & Profit, all bonds and permit fees.
- C. Architect Responsibilities:
 - 1. Consult with Contractor for consideration and selection of products, suppliers, and installers.
 - 2. Select products in consultation with Owner and transmit decision to Contractor.
 - 3. Prepare Change Order.
- D. Contractor Responsibilities:
 - 1. Assist Architect in selection of products, suppliers and installers.
 - 2. Obtain proposals from suppliers and installers and offer recommendations.
 - 3. On notification of selection by Architect, execute purchase agreement with designated supplier and installer.
 - 4. Arrange for and process shop drawings, product data, and samples. Arrange for delivery.
 - 5. Promptly inspect products upon delivery for completeness, damage, and defects. Submit claims for transportation damage.
- E. Differences in costs will be adjusted by Change Order.
- F. Allowances Schedule:
 - 1. **Allowance No. 1: Education Center & Ambassador Animal Building Signage:**
Include the sum of **Forty Five thousand dollars (\$ 45,000.00)** for all work associated with the purchase and installation of interior and exterior signage at the Education Center and Ambassador Animal Building.
 - 2. **Allowance No. 2: Event Pavilion Signage:**
Include the sum of **Five thousand dollars (\$ 5,000.00)** for all work associated with the purchase and installation of interior and exterior signage at the Event Pavilion.

3. **Allowance No. 3: Furniture for the Education Center & Ambassador Animal Building**
Include the sum of **Two hundred fifty thousand dollars (\$ 250,000.00)** for all work associated with the purchase, delivery and installation of furniture at the Education Center and Ambassador Animal Building.
4. **Allowance No. 4: Furniture for the Events Pavilion**
Include the sum of **Fifty thousand dollars (\$ 50,000.00)** for all work associated with the purchase, delivery and installation of furniture at the Events Pavilion.
5. **Allowance No. 5: Modifications necessary to new construction due to unforeseen conditions at the Education Center & Ambassador Animal Building:**
Include the sum of **Four hundred thousand dollars (\$ 400,000.00)** for modified new construction and repairs required due to unforeseen conditions at the Education Center and Ambassador Animal Building.
6. **Allowance No. 6: Modifications necessary to new construction due to unforeseen conditions at the Events Pavilion:**
Include the sum of **One hundred thousand dollars (\$ 100,000.00)** for modified new construction and repairs required due to unforeseen conditions at the Events Pavilion.
7. **Allowance No. 7: Replacement of unsuitable soil:**
Include the sum of **Fifty thousand dollars (\$ 50,000.00)** to remove and dispose off-site unsuitable materials/soils (non-hazardous) and replace with gravel and backfill.
8. **Allowance No. 8: New Electrical Service:**
Include the sum of **Eighty thousand dollars (\$ 80,000.00)** for all work associated with the purchase and installation of a new electrical service.

1.03 TESTING AND INSPECTION ALLOWANCES

- A. Costs included in Testing and Inspecting Allowances: Cost of engaging a testing and inspecting agency; execution of tests and inspecting; and reporting results.
- B. Costs not included in the Testing and Inspecting Allowance but included in the Contract Sum:
 1. Costs of incidental labor and facilities required to assist testing or inspecting agency.
 2. Costs of testing services used by Contractor separate from Contract Document requirements.
 3. Costs of retesting upon failure of previous tests as determined by Architect.
- C. Payment Procedures:
 1. Submit one copy of the inspecting or testing firm's invoice with each copy of the next application for payment.
 2. Pay invoice on approval by Architect.

D. Testing and Inspecting Allowances Schedule:

1. **Allowance No. 9: Testing and Inspection for the Education Center & Ambassador Animal Building:**

Include the sum of **Ten thousand dollars (\$ 10,000.00)** for payment of testing, or inspecting, laboratory services for compacted soils, concrete and structural welds as required by the pertinent specification sections.

2. **Allowance No. 10: Testing and Inspection for the Events Pavilion:**

Include the sum of **Ten thousand dollars (\$ 10,000.00)** for payment of testing, or inspecting, laboratory services for compacted soils, concrete and structural welds as required by the pertinent specification sections.

E. Differences in cost will be adjusted by Change Order.

1.04 Total sum of all nine above noted Allowances is

One million dollars (\$ 1,000,000.00).

PART 2 - PRODUCTS

Not Used.

PART 3 - EXECUTION

Not Used.

END OF SECTION

THIS PAGE INTENTIONALLY LEFT BLANK

SECTION 01 31 00

ADMINISTRATIVE REQUIREMENTS

PART 1 - GENERAL

1.01 SECTION INCLUDES

- A. Coordination and project conditions.
- B. Preconstruction meeting.
- C. Site mobilization meeting.
- D. Progress meetings.
- E. Preinstallation meetings.

1.02 COORDINATION AND PROJECT CONDITIONS

- A. Coordinate the scheduling, submittals, and the Work of the various Sections of the Project Manual to ensure an efficient and orderly sequence of the installation of interdependent construction elements with provisions for accommodating the items installed later.
- B. Verify that the utility requirements and characteristics of the operating equipment are compatible with the building utilities. Coordinate the Work of the various Sections having interdependent responsibilities for installing, connecting to, and placing in service, such equipment.
- C. Coordinate the space requirements, supports, and installation of the mechanical, plumbing and electrical Work, which are indicated diagrammatically on the Drawings. Follow the routing shown for the pipes, ducts, and conduit, as closely as practicable; place runs parallel with the lines of the building. Utilize spaces efficiently to maximize accessibility for other installations, for maintenance, and for repairs.
 - 1. The Contractor is to provide coordination drawings indicating size and locations of all mechanical, plumbing, fire protection and electrical work to confirm conflicts do not exist between systems. Submit four hard copies to the Architect for review prior to purchasing and fabrication of materials.
- D. In finished areas except as otherwise indicated, conceal the pipes, ducts, and wiring within the construction. Coordinate the locations of fixtures and outlets with the finish elements.
- E. Coordinate the completion and clean up of the Work of the separate Sections in preparation for Substantial Completion.
- F. After the Owner's occupancy of the premises, coordinate access to the site for correction of the defective Work and the Work not in accordance with the Contract Documents, to minimize disruption of the Owner's activities.

1.03 PRECONSTRUCTION MEETING

- A. The Architect will schedule a meeting after a Notice to Proceed is issued to the Contractor.
- B. Attendance Required: Owner, Architect, and Contractor.
- C. Agenda:
 - 1. Execution of the Owner-Contractor Agreement.
 - 2. Submission of the executed bonds and insurance certificates.
 - 3. Distribution of the Contract Documents.
 - 4. Submission of a list of Subcontractors, a list of products, schedule of values, and a progress schedule.
 - 5. Designation of the personnel representing the parties in the Contract, and the Architect.
 - 6. The procedures and processing of the field decisions, submittals, substitutions, applications for payments, proposal requests, Change Orders, and Contract closeout procedures.
 - 7. Scheduling.
- D. Record the minutes and distribute copies within two days after the meeting to the participants, with two copies to the Architect, the Owner, the participants, and those affected by the decisions made.

1.04 SITE MOBILIZATION MEETING

- A. The Architect will schedule a meeting at the Project site prior to the Contractor's occupancy.
- B. Attendance Required: The Owner, Architect, Special Consultants, and, Contractor, the Contractor's Superintendent, and major Subcontractors.
- C. Agenda:
 - 1. Use of the premises by the Owner and the Contractor.
 - 2. The Owner's requirements and occupancy.
 - 3. Construction facilities and controls provided by the Owner.
 - 4. Temporary utilities provided by the Owner.
 - 5. Survey and building layout.
 - 6. Security and housekeeping procedures.
 - 7. Schedules.
 - 8. Application for payment procedures.
 - 9. Procedures for testing.
 - 10. Procedures for maintaining the record documents.
 - 11. Requirements for start-up of the equipment.
 - 12. Inspection and acceptance of the equipment put into service during the construction period.
- D. Record the minutes and distribute the copies within two days after the meeting to the participants, with two copies to the Architect, Owner, participants, and those affected by the decisions made.

1.05 PROGRESS MEETINGS

- A. Schedule and administer the meetings throughout the progress of the Work at maximum bi-weekly (14 day) intervals.
- B. Make arrangements for the meetings, prepare the agenda with copies for the participants, and preside at the meetings.
- C. Attendance Required: The job superintendent, major subcontractors and suppliers, the Owner, Architect, as appropriate to agenda topics for each meeting.
- D. Agenda:
 - 1. Review the minutes of previous meetings.
 - 2. Review of the Work progress.
 - 3. Field observations, problems, and decisions.
 - 4. Identification of the problems which impede the planned progress.
 - 5. Review of the submittals schedule and status of the submittals.
 - 6. Review of the off-site fabrication and delivery schedules.
 - 7. Maintenance of the progress schedule.
 - 8. Corrective measures to regain the projected schedules.
 - 9. Planned progress during the succeeding work period.
 - 10. Coordination of the projected progress.
 - 11. Maintenance of the quality and work standards.
 - 12. Effect of the proposed changes on the progress schedule and coordination.
 - 13. Other business relating to the Work.
- E. Record the minutes and distribute the copies within two days after the meeting to the participants, with two copies to the Architect, Owner, participants, and those affected by the decisions made.

1.06 PREINSTALLATION MEETING

- A. When required in the individual specification Sections, convene a preinstallation meeting at the site prior to commencing the Work of the Section.
- B. Require attendance of the parties directly affecting, or affected by, the Work of the specific Section.
- C. Notify the Architect four days in advance of the meeting date.
- D. Prepare an agenda and preside at the meeting:
 - 1. Review the conditions of installation, preparation and installation procedures.
 - 2. Review coordination with the related work.
- E. Record the minutes and distribute the copies within two days after the meeting to the participants, with two copies to the Architect, Owner, participants, and those affected by the decisions made.

PART 2 - PRODUCTS

Not used.

PART 3 - EXECUTION

Not used.

END OF SECTION

SECTION 01 33 00

SUBMITTAL PROCEDURES

PART 1 - GENERAL

1.01 SECTION INCLUDES

- A. Submittal procedures.
- B. Construction progress schedules.
- C. Proposed products list.
- D. Method for Submission of Shop Drawings and Product Data
- E. Product data.
- F. Shop drawings.
- G. Samples.
- H. Design data.
- I. Test reports.
- J. Certificates.
- K. Manufacturer's instructions.
- L. Manufacturer's field reports.
- M. Erection drawings.
- N. Construction photographs.

1.02 SUBMITTAL PROCEDURES

- A. Master List Submittal:
 - 1. Submit a master list of the required submittals with a proposed date for each item to be submitted.
 - 2. Show the date submittal was sent, days since submittal was sent, status of submittal, date submittal was received in return, and any date associated with resubmittals.
 - 3. Up date master list with each submission and response.
 - 4. Issue copy of master list at least monthly to the Architect.
- B. Transmit each submittal with a transmittal form.
- C. Sequentially number the transmittal form. Mark revised submittals with the original number and a sequential alphabetic suffix.

- D. Identify the Project, Contractor, subcontractor and supplier; the pertinent drawing and detail number, and the specification Section number, appropriate to the submittal.
- E. Apply a Contractor's stamp, signed or initialed, certifying that the review, approval, verification of products required, field dimensions, adjacent construction Work, and coordination of the information is in accordance with the requirements of the Work and the Contract Documents. The Contractor is to mark-up the submittal as required to indicate the exact materials the submittal addresses including at a minimum, sizes, locations, uses, colors, etc.
- F. Schedule submittals to expedite the Project and deliver to the Architect at their business address. Coordinate the submission of related items. Upon completion of the submittal's review, the Architect's office will notify the Contractor. The Contractor is then responsible to pick-up the submittals in a timely manner.
- G. For each submittal for review, allow fifteen (15) calendar days excluding the delivery time to and from the Contractor.
- H. Identify the variations from the Contract Documents and the Product or system limitations that may be detrimental to a successful performance of the completed Work.
- I. Allow space on the submittals for the Contractor's and the Architect's review stamps.
- J. When revised for resubmission, identify the changes made since the previous submission.
- K. Distribute copies of the reviewed submittals as appropriate. Instruct the parties to promptly report an inability to comply with the Contract requirements.
- L. Submittals not requested will not be recognized or processed. The Contractor will be notified of the submittal's refusal.
- M. The Contractor will compensate the Architect and all consulting Engineers for services performed reviewing submittals beyond the original review and two follow-up reviews of the same product, material, sample or assembly. The compensation will be made through a credit change order that will reduce the total contract amount.

1.03 CONSTRUCTION PROGRESS SCHEDULES

- A. Submit preliminary outline Schedules within fifteen (15) days after the date of receipt of a Notice to Proceed for coordination with the Owner's requirements. After a review, submit detailed schedules within fifteen (15) days modified to accommodate the revisions recommended by the Architect.
- B. Submit revised Progress Schedules with each Application for Payment.
- C. Distribute copies of the reviewed schedules to the Project site file, subcontractors, suppliers, and other concerned parties.
- D. Instruct the recipients to promptly report, in writing, the problems anticipated by the projections indicated in the schedules.

- E. Submit a computer generated horizontal bar chart with a separate line for each major portion of the Work or operation, or section of the Work, identifying the first workday of each week.
- F. Show a complete sequence of construction by activity, identifying the Work of separate stages and other logically grouped activities. Indicate the early and late start, the early and late finish, float dates, and the duration.
- G. Indicate an estimated percentage of completion for each item of the Work at each submission.
- H. Provide a separate schedule of submittal dates for shop drawings, product data, and samples, including Owner furnished Products and Products identified under Allowances, if any, and the dates reviewed submittals will be required from the Architect. Indicate the decision dates for selection of the finishes.
- I. Indicate the delivery dates for Owner furnished Products, and for Products identified under Allowances.
- J. Revisions to Schedules:
 - 1. Indicate the progress of each activity to the date of submittal, and the projected completion date of each activity.
 - 2. Identify the activities modified since the previous submittal, major changes in the scope, and other identifiable changes.
 - 3. Provide a narrative report to define the problem areas, the anticipated delays, and impact on the Schedule. Report the corrective action taken, or proposed, and its effect including the effect of changes on the schedules of separate contractors.

1.04 PROPOSED PRODUCTS LIST

- A. Within fifteen (15) days after the date of receipt of a Notice to Proceed, submit a list of major products proposed for use, with the name of the manufacturer, the trade name, and the model number of each product.
- B. For the products specified only by reference standards, give the manufacturer, trade name, model or catalog designation, and reference standards.
- C. With each product listed, indicate the submittal requirements specified to be adhered to, and an indication of relevant "long-lead-time" information, when appropriate.

1.05 METHOD FOR SUBMISSION OF SHOP DRAWING AND PRODUCT DATA

- A. Method of electronic or hard copy delivery of shop drawing and data submittals is to be discussed with Architect at Preconstruction meeting.
Use one of the three methods listed below:
 - 1. Use an internet-based system agreed upon by the Architect and Contractor.
Comply with required transmittal and data formats using numbering system approved by Architect.
Assemble submittal package into a single indexed file incorporating submittal and cover sheet explaining project name, number, Architect, Contractor and submittal number.
 - 2. Email an electronic format (PDF) copy to the Architect.
Comply with required transmittal and data formats using numbering system approved by

Architect.

Assemble submittal package into a single indexed file incorporating submittal and cover sheet explaining project name, number, Architect, Contractor and submittal number.

3. Hard copies delivered to the Architect are to be submitted with the number of copies that the Contractor requires, plus three copies the Architect will retain.

- B. All shop drawings 24" x 36" or larger are to be delivered to the Architect in hard copy format as noted in Method 3 above.
- C. All submittals are to include a Contractor's review stamp confirming approval prior to submission to the Architect.
- D. The Architect will return the reviewed submittal to the Contractor for distribution to subcontractors, suppliers, fabricators, and others as necessary for proper performance of the Work.
- E. Submit color samples on actual product material for final color selection by sending them via postal or delivery service directly to the Architect's office.

1.06 PRODUCT DATA

- A. Product Data: Submit to the Architect for review for the limited purpose of checking for conformance with the information given and the design concept expressed in the Contract Documents. Provide copies and distribute in accordance with the SUBMITTAL PROCEDURES article and for the record documents purposes described in Section 01 78 00.
- B. Mark each copy to identify the applicable products, models, options, and other data. Supplement the manufacturers' standard data to provide the information specific to this Project.
- C. Indicate the product utility and electrical characteristics, the utility connection requirements, and the location of utility outlets for service for functional equipment and appliances.
- D. After receiving approved submittals, distribute in accordance with the Submittal Procedures article above and provide copies for record documents described in Section 01 78 00.

1.07 SHOP DRAWINGS

- A. Shop Drawings: Submit to the Architect for review for the limited purpose of checking for conformance with the information given and the design concept expressed in the Contract Documents. Produce copies and distribute in accordance with the SUBMITTAL PROCEDURES article and for the record documents purposes described in Section 01 78 00.
- B. Indicate the special utility and electrical characteristics, the utility connection requirements, and the location of utility outlets for service for functional equipment and appliances.
- C. Submit according to method agreed upon in Paragraph 1.05 or if submitting hard copies, submit the number of copies that the Contractor requires, plus three copies the Architect will retain.

1.08 SAMPLES

- A. Samples: Submit to the Architect for review for the limited purpose of checking for conformance with the information given and the design concept expressed in the Contract Documents. Produce duplicates and distribute in accordance with the SUBMITTAL PROCEDURES article and for the record documents purposes described in Section 01 78 00.
- B. Samples For Selection as Specified in Product Sections:
 - 1. Submit to the Architect for aesthetic, color, or finish selection.
 - 2. Submit samples of the finishes, indicating colors, texture, and patterns for the Architect's selection.
 - 3. After review, produce duplicates and distribute in accordance with the SUBMITTAL PROCEDURES article and for the record documents purposes described in Section 01 78 00.
- C. Submit samples to illustrate the functional and aesthetic characteristics of the product, with integral parts and attachment devices. Coordinate the sample submittals for interfacing Work.
- D. Include identification on each sample, with the full Project information.
- E. Submit the number of samples specified in the individual specification Sections; the Architect will retain one sample.
- F. Reviewed samples, which may be used in the Work, are indicated in the individual specification Sections.
- G. Samples will not be used for testing purposes unless they are specifically stated to be in the specification Section.

1.09 DESIGN DATA

- A. Submit for the Architect's knowledge as contract administrator.
- B. Submit for information for the limited purpose of assessing conformance with the information given and the design concept expressed in the Contract Documents.

1.10 TEST REPORTS

- A. Submit for the Architect's knowledge as contract administrator.
- B. Submit test reports for information for the limited purpose of assessing conformance with the information given and the design concept expressed in the Contract Documents.

1.11 CERTIFICATES

- A. When specified in the individual specification Sections, submit certification by the manufacturer, installation/application subcontractor, or the Contractor to the Architect, in the quantities specified for the Product Data.
- B. Indicate that the material or product conforms to or exceeds the specified requirements. Submit supporting reference data, affidavits, and certifications as appropriate.
- C. Certificates may be recent or previous test results on the material or product, but must be acceptable to the Architect.

1.12 MANUFACTURER'S INSTRUCTIONS

- A. When specified in the individual specification Sections, submit printed instructions for delivery, storage, assembly, installation, start-up, adjusting, and finishing, to the Architect for delivery to the Owner in the quantities specified for Product Data.
- B. Indicate the special procedures, and the perimeter conditions requiring special attention, and the special environmental criteria required for application or installation.

1.13 MANUFACTURER'S FIELD REPORTS

- A. Submit reports for the Architect's benefit as contract administrator.
- B. Submit the report in duplicate within thirty (30) days of observation to the Architect for information.
- C. Submit for information for the limited purpose of assessing conformance with the information given and the design concept expressed in the Contract Documents.

1.14 ERECTION DRAWINGS

- A. Submit drawings for the Architect's benefit as contract administrator.
- B. Submit for information for the limited purpose of assessing conformance with the information given and the design concept expressed in the Contract Documents.
- C. Data indicating inappropriate or unacceptable Work may be subject to action by the Architect.

1.15 CONSTRUCTION PHOTOGRAPHS

- A. Take digital photographs of the site and construction throughout the progress of the Work produced by an experienced photographer.
- B. Provide minimum ten (10) – photographs per week. All photographs are to have the date imprinted on the face of the photograph.
- C. Take photographs from differing directions, as appropriate, and as may be requested by the Architect and the Owner, indicating the relative progress of the Work.

- D. Submit all digital photographs on a compact disc in J-PEG or PDF format at the end of the project as part of the closeout documents. Submit photographs during construction if requested by the Architect.

PART 2 - PRODUCTS

Not Used.

PART 3 - EXECUTION

Not Used.

END OF SECTION

THIS PAGE INTENTIONALLY LEFT BLANK

SECTION 01 43 00

QUALITY REQUIREMENTS

PART 1 - GENERAL

1.01 SECTION INCLUDES

- A. Quality control and control of installation.
- B. Verification of Credentials and Licenses.
- C. Safety Awareness Policy
- D. Tolerances
- E. References.
- F. Mock-up requirements.
- G. Testing and inspection services.
- H. State Mandated Structural Special Inspections
- I. Manufacturers' field services.
- J. Commissioning of HVAC and Electrical Systems

1.02 QUALITY CONTROL AND CONTROL OF INSTALLATION

- A. Monitor a quality control over suppliers, manufacturers, products, services, site conditions, and workmanship, to produce Work of the specified quality.
- B. Comply with the manufacturers' instructions, including each step in sequence.
- C. When the manufacturers' instructions conflict with the Contract Documents, request a clarification from the Architect before proceeding.
- D. Comply with the specified standards as a minimum quality for the Work except where more stringent tolerances, codes, or specified requirements indicate higher standards or more precise workmanship.
- E. Perform the Work by persons qualified to produce the required and specified quality.
- F. Verify that field measurements are as indicated on the Shop Drawings or as instructed by the manufacturer.
- G. Secure products in place with positive anchorage devices designed and sized to withstand stresses, vibration, physical distortion, or disfigurement.

- H. Field measurements
 - 1. Verify actual measurements/openings by field measurements before fabrication; show recorded measurements on shop drawings. Coordinate field measurements, fabrication scheduled with construction progress to avoid construction delays.

- I. The Contractor, by approving and submitting Shop Drawings, Product Data, Samples, and similar submittals thereby represent that they have determined and verified all dimensions, quantities, field dimensions, relations to existing work, coordination with work to be installed later, coordination with information on previously accepted Shop Drawings, Product Data, Samples, or similar submittals and verification of compliance with all the requirements of the Contract Documents. The accuracy of all such information is the responsibility of the Contractor. In reviewing Shop Drawings, Product Data, Samples, and similar submittals the Architect shall be entitled to rely upon the Contractor's representation that such information is correct and accurate.

- J. Concrete Installation Quality Control
 - 1. **NO** concrete is to be installed without prior examination by the Architect of all forms, reinforcement and vapor barriers and receipt of a written approval by the Architect.
 - 2. The Architect is to be notified a minimum of three (3) working days prior to each pour.
 - 3. All inconsistencies will be corrected, re-inspected and approved by the Architect prior to installation of the concrete.

1.03 VERIFICATION OF CREDENTIALS AND LICENSES

- A. All persons employed on the project site must have appropriate and current credentials and licenses in their possession, at the project site, for the work they are performing.
- B. Be forewarned that inspectors will be checking for verification of credentials and licenses of both union and non-union persons, in their onsite inspections.
- C. Inspectors will also be reviewing Contractor's Certified Monthly Payroll Records for conformance with State Wage Rate requirements.
- D. Those persons without the appropriate credentials and licenses will be subject to dismissal from the project site.

1.04 SAFETY AWARENESS POLICY

- A. In accordance with Rhode Island General Laws, Title 28, S28-20-35 5.1 Safety awareness program required. (Effective January 1, 2002.) all contractors who bid on municipal and state construction projects with a total project cost of One Hundred Thousand Dollars(\$100,000.00) or more, shall have an OSHA "ten hour safety construction program" for their on-site employees. The training shall utilize instructors trained by the Occupational Safety Health Administration, using OSHA approved curriculum. Graduates shall receive a card from the U. S. Department of Labor Occupational Safety and Health Administration certifying the successful completion of the training course. The director of the Rhode Island Department of Labor and Training shall promulgate rules, regulations and penalties to enforce provisions of this section.

- B. The Contractor is required to conform to all applicable OSHA requirements on this project.

1.05 TOLERANCES

- A. Monitor the fabrication and installation tolerance control of products to produce acceptable Work. Do not permit tolerances to accumulate.
- B. Comply with the manufacturers' tolerances. When the manufacturers' tolerances conflict with the Contract Documents, request a clarification from the Architect before proceeding.
- C. Adjust products to appropriate dimensions; position before securing products in place.

1.06 REFERENCES

- A. For products or workmanship specified by association, trade, or other consensus standards, comply with requirements of the standard, except when more rigid requirements are specified or are required by applicable codes.
- B. Conform to reference standard by the date of issue current on the date of the Contract Documents, except where a specific date is established by code.
- C. Obtain copies of the standards where required by the product specification Sections.
- D. When the specified reference standards conflict with the Contract Documents, request a clarification from the Architect before proceeding.
- E. Neither the contractual relationships, duties, nor responsibilities of the parties in the Contract, nor those of the Architect, shall be altered from the Contract Documents by mention or inference otherwise in reference documents.

1.07 MOCK-UP REQUIREMENTS

- A. Tests will be performed under the provisions identified in this Section and identified in the respective product specification Sections.
- B. Assemble and erect the specified items with the specified attachment and anchorage devices, flashing, seals, and finishes.
- C. Accepted mock-ups shall be a comparison standard for the remaining Work.
- D. Where the mock-up has been accepted by the Architect and is specified in the product specification Sections to be removed, remove the mock-up and clear the area when directed to do so by the Architect.

1.08 TESTING AND INSPECTION SERVICES

- A. The Contractor will submit the name of an independent firm to the Architect for approval by the Owner, to perform the testing and inspection services. All fees to be paid to the independent firm will

be deducted from the Testing Allowance stated in Section 01 21 00. The Contractor is to submit the testing firm's invoice as backup to be included with a Change Order deducting the amount from the Testing Allowance.

- B. The independent firm will perform the tests, inspections and other services specified in the individual specification Sections.
 - 1. Laboratory: Authorized to operate in the location in which the Project is located.
 - 2. Laboratory Staff: Maintain a full time registered Engineer on staff to review the services.
 - 3. Testing Equipment: Calibrated at reasonable intervals with devices of an accuracy traceable to either the National Bureau of Standards or to the accepted values of natural physical constants.
- C. Testing, inspections and source quality control may occur on or off the project site. Perform off-site testing as required by the Architect.
- D. Reports will be submitted by the independent firm to the Architect, Owner and the Contractor, in duplicate, or electronically, indicating the observations and results of tests and indicating the compliance or non-compliance with Contract Documents.
- E. Cooperate with the independent firm; furnish samples of the materials, design mix, equipment, tools, storage, safe access, and the assistance by incidental labor as requested.
 - 1. Notify the Architect and the independent firm 24 hours prior to the expected time for operations requiring services.
 - 2. Arrange with the independent firm and pay for additional samples and tests required for the Contractor's use.
- F. Testing and employment of the testing firm shall not relieve the Contractor of an obligation to perform the Work in accordance with the requirements of the Contract Documents.
- G. Re-testing or re-inspection required because of a non-conformance to the specified requirements is to be performed by the same independent firm on instructions by the Architect. Payment for the re-testing or re-inspection will be the Contractor's responsibility.
- H. Testing Firm Responsibilities:
 - 1. Test samples of mixes submitted by the Contractor.
 - 2. Provide qualified personnel at the site. Cooperate with the Architect and the Contractor in performance of services.
 - 3. Perform specified sampling and testing of the products in accordance with the specified standards.
 - 4. Ascertain compliance of the materials and mixes with the requirements of the Contract Documents.
 - 5. Promptly notify the Architect and the Contractor of observed irregularities or non-conformance of the Work or products.
 - 6. Attend the preconstruction meetings and the progress meetings.
- I. Testing Firm Reports: After each test, promptly submit two copies of the report to the Architect and to the Contractor. When requested by the Architect, provide an interpretation of the test results. Include the following:
 - 1. Date issued.
 - 2. Project title and number.

3. Name of inspector.
4. Date and time of sampling or inspection.
5. Identification of product and specifications section.
6. Location in the Project.
7. Type of inspection or test.
8. Date of test.
9. Results of tests.
10. Conformance with Contract Documents.

J. Limits on Testing Firm:

1. Testing Firm may not release, revoke, alter, or enlarge on the requirements of the Contract Documents.
2. Testing Firm may not approve or accept any portion of the Work.
3. Testing Firm may not assume any duties of the Contractor.
4. Testing Firm has no authority to stop the Work.

1.09 STATE MANDATED STRUCTURAL SPECIAL INSPECTIONS

- A. Included, following this Specification Section, is the state mandated Statement of Special Inspections from the Structural Engineer of Record and the Schedule of Special Inspection Services for this project.

1.10 MANUFACTURERS' FIELD SERVICES

- A. When specified in the individual specification Sections, require the material or Product suppliers, or manufacturers, to provide qualified staff personnel to observe the site conditions, the conditions of the surfaces and installation, the quality of workmanship, the start-up of equipment, or test, adjust and balance of equipment as applicable, and to initiate instructions when necessary.
- B. Submit the qualifications of the observer to the Architect thirty (30) days in advance of the required observations. The Observer is subject to approval by the Architect.
- C. Report the observations and the site decisions or instructions given to the applicators or installers that are supplemental or contrary to the manufacturers' written instructions.
- D. Refer to Section 01 33 00 - Submittal Procedures, Manufacturer's Field Reports article.

1.11 COMMISSIONING OF HVAC AND ELECTRICAL SYSTEMS

A. Commissioning Agency

1. A commissioning agency (CA) will be contracted directly with the owner for this project. The CA has overall responsibility for planning and coordinating the commissioning process. However commissioning involves all parties to the construction process, including the Contractor.

B. Contractor Responsibility

1. This Section of the specifications defines the Contractor's responsibilities with respect to the commissioning process. Each Contractor and Sub-Contractor shall review this Section, and shall include in their bids for carrying out the work described, as it applies to each Division and Section of these specifications, individually and collectively.

C. Description of Work

1. The purpose of the commissioning process is to provide the owner of the facility with assurance that the mechanical and electrical systems have been installed according to the contract documents, and operate within the performance guidelines set out in the design intent documents and these specifications. The CA will provide the owner with an unbiased, objective view of the system's installation, operation, and performance. The commissioning process does not take away or reduce the responsibility of the installing contractors to provide a finished product, installed and fully functional in accordance with the contract documents.
2. Commissioning is intended to enhance the quality of system start-up and aid in the orderly completion and transfer of systems for beneficial use by the owner. The CA will be the leader of the commissioning team, planning and coordinating all commissioning activities in conjunction with the design professionals, contractor, subcontractors, manufacturers and equipment suppliers.
3. The General Contractor, Mechanical Contractor, Electrical Contractor and all Division 15 & 16 sub-contractors shall be responsible for cooperating, and coordinating their work, with the CA. They shall also be responsible for carrying out all the physical activities required for installation of components and systems, and operating them during the commissioning process as required in this Section.

D. Related Documents

1. Drawings and general provisions of the contract, including general and supplementary conditions, general mechanical & electrical provisions and applicable Division 23 and 26 Specification sections, apply to work of this section.
2. The following sections pertain directly with the commissioning requirements:
Section 01 91 00 - General Commissioning Requirements
Division 23 - Commissioning of HVAC
Division 26 - Commissioning of Electrical

PART 2 - PRODUCTS

Not Used.

PART 3 - EXECUTION

Not used.

END OF SECTION

SECTION 01 50 00

TEMPORARY FACILITIES AND CONTROLS

PART 1 - GENERAL

1.01 SECTION INCLUDES

- A. Temporary Utilities:
 - 1. Temporary electricity.
 - 2. Temporary lighting for construction purposes.
 - 3. Temporary heating.
 - 4. Temporary cooling.
 - 5. Temporary ventilation.
 - 6. Telephone service.
 - 7. Computer E-mail service
 - 8. Temporary water service.
 - 9. Temporary sanitary facilities.

- B. Construction Facilities:
 - 1. Field offices, trailers and sheds.
 - 2. Temporary scaffolding
 - 3. Hoisting
 - 4. Vehicular access.
 - 5. Parking.
 - 6. Progress cleaning and waste removal.
 - 7. Project identification.
 - 8. Traffic regulation.

- C. Temporary Controls:
 - 1. Barriers.
 - 2. Enclosures and fencing.
 - 3. Security.
 - 4. Water control.
 - 5. Dust control.
 - 6. Erosion and sediment control.
 - 7. Noise control.
 - 8. Pest control.
 - 9. Pollution control.
 - 10. Rodent control.

- D. Removal of utilities, facilities, and controls.

1.02 TEMPORARY ELECTRICITY

- A. The Owner will pay the cost of electricity used. Utilize the Owner's existing power service. Exercise measures to conserve energy.

- B. Provide a temporary electric feeder from an existing building, or from the electrical service at the location as directed by the Architect. Do not disrupt the Owner's use of service.

- C. Complement the existing power service capacity and characteristics as required for construction operations.
- D. Provide power outlets, with branch wiring and distribution boxes located at each floor or as required for construction operations. Provide flexible power cords as required for portable construction tools and equipment.
- E. Provide main service disconnect and over-current protection at a convenient location, or a feeder switch at the source distribution equipment or meter.
- F. Permanent convenience receptacles may be utilized during construction.

1.03 TEMPORARY LIGHTING FOR CONSTRUCTION PURPOSES

- A. Provide and maintain lighting for construction operations to achieve a minimum lighting level of 2 watt/sq ft.
- B. Provide and maintain 1 watt/sq ft lighting to exterior staging and storage areas after dark for security purposes.
- C. Provide and maintain 0.25 watt/sq ft lighting to interior work areas after dark for security purposes.
- D. Provide branch wiring from power source to distribution boxes with lighting conductors, pigtails and lamps for specified lighting levels.
- E. Maintain lighting and provide routine repairs.
- F. Permanent building lighting may be utilized during construction.

1.04 TEMPORARY HEATING

- A. The Contractor will provide and pay for temporary heating devices and associated fuel as needed to maintain the specified conditions for construction operations.
- B. Any modifications, temporary devices and associated fuel will be paid for by the Contractor.
- C. Enclose the building prior to activating the temporary heat in accordance with the Enclosure article in this Section.
- D. Prior to the operation of permanent equipment for temporary heating purposes, verify that the installation is approved for operation, the equipment is lubricated and the filters are in place. Provide and pay for the operation, maintenance, and the regular replacement of filters and worn or consumed parts.
- E. Maintain a minimum ambient temperature of 50 degrees F in the areas where construction is in progress, unless indicated otherwise in the product Sections.
- F. Permanent building heating systems may be utilized during construction.

1.05 TEMPORARY COOLING

- A. The Contractor will provide and pay for cooling devices and associated fuel/electricity as needed to maintain the specified conditions for construction operations.
- B. Enclose the building prior to activating the temporary cooling in accordance with the Enclosure article in this Section.
- C. Prior to operation of the permanent equipment for temporary cooling purposes, verify that the installation is approved for operation, the equipment is lubricated and the filters are in place. Provide and pay for the operation, maintenance, and the regular replacement of the filters and worn or consumed parts.
- D. Maintain a maximum ambient temperature of 80 degrees F in the areas where construction is in progress, unless indicated otherwise in the specifications.
- E. Permanent building cooling systems may be utilized during construction.

1.06 TEMPORARY VENTILATION

- A. Ventilate the enclosed area to achieve a curing of materials, to dissipate humidity, and to prevent the accumulation of dust, fumes, vapors, or gases.
- B. Utilize the permanent ventilation equipment as necessary. Supplement with temporary fan units as required to maintain clean air for construction operations. Replace all filters on permanent ventilation equipment at substantial completion of the project.

1.07 TELEPHONE SERVICE

- A. The Contractor is required to ensure the on-site Project Supervisor maintains a cell phone in their possession for the duration of the Contract.

1.08 COMPUTER E-MAIL SERVICE

- A. Provide, maintain and pay for a computer, tablet or equal electronic device with an internet connection capable of receiving e-mail at the Contractor's field office at the time of project mobilization and throughout the construction period.

1.09 TEMPORARY WATER SERVICE

- A. The Owner will pay the cost of temporary water. Exercise measures to conserve. Utilize the Owner's existing water system, extend and supplement with temporary devices as needed to maintain the specified conditions for construction operations.
- B. Extend branch piping with outlets located so that water is available by hoses with threaded connections. Provide temporary pipe insulation to prevent freezing.

1.10 TEMPORARY SANITARY FACILITIES

- A. Provide and maintain the required facilities and enclosures. Existing facility use is not permitted. Provide facilities at the time of project mobilization.

1.11 FIELD OFFICES, TRAILERS AND SHEDS

- A. Contractor's Field Office: Provide a weather tight portable building or trailer with lighting, electrical outlets, heating, cooling and ventilating equipment, and equipped with sturdy furniture, drawing rack, and drawing display table.
 - 1. Provide a space for Project meetings, with table and chairs to accommodate 8 persons.
 - 2. Locate the offices and sheds a minimum distance of 30 feet from existing or new structures in location agreed upon by Architect and Owner.
 - 3. When permanent facilities are enclosed with operable utilities, the contractor may relocate the offices and storage into the building, with the written agreement of the Owner, and then may remove temporary buildings.
- B. Storage Areas, Trailers and Sheds: Size to the storage requirements for the products of the individual Sections, allowing for access and orderly provision for the maintenance and for the inspection of Products to the requirements of Section 01 60 00.
- C. Preparation: Fill and grade the sites for the temporary structures to provide drainage away from the buildings.
- D. Installation:
 - 1. Install the office spaces ready for occupancy fifteen (15) days after receipt of Notice to Proceed
 - 2. Parking: Two hard surfaced parking spaces for use by the Owner and the Architect connected to the office by a hard surfaced walk.
- E. Maintenance and Cleaning
 - 1. Weekly janitorial services for the offices, periodic cleaning and maintenance for the office and storage areas.
 - 2. Maintain the approach walks free of mud, water, and snow.
- F. Removal: At the completion of the Work remove the buildings, foundations, utility services, and debris. Restore the areas.

1.12 TEMPORARY SCAFFOLDING

- A. Contractor is to provide temporary scaffolding as necessary for construction purposes.
- B. The scaffolding is to be braced properly, assembled and installed as required to meet all OSHA requirements.
- C. Remove from the site all scaffolding, associated bracing and supports upon completion of construction. Repair all surfaces and site to original condition including all landscaping, grass and hardscape.

- D. Scaffolding must allow for unimpeded entry and egress from the building at all times when it is occupied by employees or the public.

1.13 HOISTING

- A. Contractor is responsible for all hoisting required to facilitate, serve, stock, clean, and complete the Work. Include all costs for operating engines, fuel, delivery and removal, mobilization, staging, protection of grades and surfaces, and equipment. All surfaces damaged by hoisting equipment or crane are to be cleaned and repaired to match original condition. All damaged grass is to receive loam and seed to match existing.

1.14 VEHICULAR ACCESS

- A. Provide unimpeded access for emergency vehicles. Maintain 20 foot width driveways with turning space between and around combustible materials.
- B. Provide and maintain access to fire hydrants and control valves free of obstructions.
- C. Remove mud from construction vehicle wheels before entering streets. Cleanup dirt, rocks, and debris that fall on street from construction vehicles.

1.15 PARKING

- A. Arrange for temporary surface parking areas to accommodate the construction personnel.
- B. Location must be approved by the Owner.
- C. Use of existing parking facilities by construction personnel is permitted.
- D. When site space is not adequate, arrange through the Owner for additional off-site parking.
- E. Use of designated existing on-site streets and driveways for construction traffic is [not] permitted. Tracked vehicles are not allowed on paved areas.
- F. Do not allow heavy vehicles or construction equipment in parking areas.

1.16 PROGRESS CLEANING AND WASTE REMOVAL

- A. Maintain areas free of waste materials, debris, and rubbish. Maintain the site in a clean and orderly condition.
- B. Collect and remove waste materials, debris, and rubbish from the site periodically, weekly, or daily, as necessary to prevent an on-site accumulation of waste material, debris, and rubbish, and dispose off-site.
- C. The General Contractor is responsible to provide and maintain dumpsters for all trades unless other arrangements are made with Subcontractors.

- D. Open free-fall chutes are not permitted. Terminate closed chutes into appropriate containers with lids.
- E. Remove debris and rubbish from pipe chases, plenums, attics, crawl spaces, and other or remote spaces, prior to enclosing the space.
- F. Sweep and vacuum clean the interior areas prior to the start of surface finishing, and continue cleaning to eliminate dust.

1.17 PROJECT IDENTIFICATION

- A. Project Identification Sign:
 - 1. One sign, 32 sq ft area (4'x8'), bottom 4 feet above the ground.
 - 2. Sign Backing Material: minimum 3/4" plywood A-B exterior grade APA
 - 3. Posts: 4"x4" pressure treated imbedded into ground minimum 3'-6".
 - 4. Fasteners: Use minimum 1/2-inch diameter button head carriage bolts to fasten sign panels to supporting structures or #10 x 2 1/2" zinc wood screws spaced at 6" on center.
 - 5. The plywood will be faced with a solid vinyl signage material adhered to the surface containing the information below.
 - 6. Content:
 - a. Project title, and name & logo of the Owner.
 - b. Names and titles of the authorities.
 - c. Names and titles of the Architect and Consultants.
 - d. Name of the Prime Contractor.
 - e. Optional rendering of project.
 - 7. Graphic design, colors and style of lettering is to be provided by the Architect.
 - 8. Printing company shall submit the layout and design to Architect for approval prior to printing sign.
 - 9. Design the sign and the structure to withstand a 60 miles/hr wind velocity.
- B. Installation:
 - 1. Install the project identification sign within fifteen (15) days after the date of receipt of the Notice to Proceed.
 - 2. Erect at the designated location or as approved by the Architect.
 - 3. Erect the supports and framing on a secure foundation, rigidly braced and framed to resist wind loading.
 - 4. Install the sign surface plumb and level. Anchor securely.
 - 5. Paint exposed surfaces of the sign, supports, and framing.
- C. Maintenance: Maintain the signs and supports clean, repair deterioration and damage.
- D. Removal: Remove the signs, framing, supports, and foundations at the completion of the Project and restore the area.
- E. Project Informational Signs:
 - 1. Painted informational signs of same colors and lettering as the Project Identification sign, or standard products; size lettering to provide legibility at 100 foot distance.
 - 2. Provide sign at each field office, storage shed, and directional signs to direct traffic into and within site. Relocate as the Work progress requires.

3. No other signs are allowed without the Owner's permission except those required by law.

1.18 TRAFFIC REGULATION

- A. Signs, Signals, And Devices:
 1. Post Mounted and Wall Mounted Traffic Control and Informational Signs: As approved by local jurisdictions.
 2. Traffic Cones and Drums, Flares and Lights: As approved by local jurisdictions.
 3. Flagperson Equipment: As required by local jurisdictions.
- B. Flag Persons: Provide trained and equipped flag persons to regulate the traffic when construction operations or traffic encroach on the public traffic lanes.
- C. Flares and Lights: Use flares and lights during the hours of low visibility to delineate the traffic lanes and to guide traffic.
- D. Haul Routes:
 1. Consult with the authority having jurisdiction; establish the public thoroughfares to be used for haul routes and site access.
 2. Confine the construction traffic to the designated haul routes.
 3. Provide traffic control at the critical areas of the haul routes to regulate traffic, to minimize interference with the public traffic.
- E. Traffic Signs:
 1. At approaches to the site and on site, install at crossroads, detours, parking areas, and elsewhere as needed to direct the construction and affected public traffic.
 2. Relocate as the Work progresses, to maintain effective traffic control.
- F. Removal:
 1. Remove equipment and devices when no longer required.
 2. Repair damage caused by installation.
 3. Remove post settings to a depth of 2 feet.

1.19 BARRIERS

- A. Provide barriers to prevent unauthorized entry to the construction areas and to protect existing facilities and adjacent properties from damage from the construction operations, or demolition.
- B. Provide protection for plants designated to remain. Replace damaged plants.
- C. Protect non-owned vehicular traffic, stored materials, site, and structures from damage.

1.20 ENCLOSURES AND FENCING

- A. Construction: Commercial grade chain link fence.
 1. Provide a six (6) foot high temporary fence around the construction site; equip with vehicular and pedestrian gates with locks. Provide one set of keys to all gates to the owner.
 2. Provide a ten (10) foot high temporary fence around a portion of the construction site; equip with vehicular and pedestrian gates with locks. Provide one set of keys to all gates to the owner.

Coordinate this fence with the existing zoo fence. This fence needs to be inserted into the ground. Verify exact location with Architect.

- B. Exterior Enclosures:
 - 1. Provide a temporary insulated weather tight closure of exterior openings to accommodate acceptable working conditions and protection for the products, to allow for temporary heating and maintenance of the required ambient temperatures identified in the individual specification sections, and to prevent entry of unauthorized persons. Provide access doors with self-closing hardware and locks.
 - 2. Provide temporary roofing as specified.

1.21 SECURITY

- A. Security Program:
 - 1. Protect the Work, the existing premises, or the Owner's operations from theft, vandalism, and unauthorized entry.
 - 2. Initiate the program at the mobilization.
 - 3. Maintain the program throughout the construction period until Owner occupancy.
- B. Entry Control:
 - 1. Restrict the entrance of persons and vehicles into the Project site, or the existing facilities.
 - 2. Allow entrance only to authorized persons with the proper identification.
 - 3. Maintain a log of workers and visitors and make available to the Owner on request.
 - 4. Coordinate the access of the Owner's personnel to the site in coordination with the Owner's security forces.

1.22 WATER CONTROL

- A. Grade the site to drain. Maintain excavations free of water. Provide, operate, and maintain pumping equipment as necessary.
- B. Protect the site from puddling or running water. Provide water barriers as required to protect the site from soil erosion.

1.23 DUST CONTROL

- A. Execute the Work by methods to minimize raising dust from construction operations.
- B. Provide positive means to prevent air-borne dust from dispersing into the atmosphere.

1.24 EROSION AND SEDIMENT CONTROL

- A. Plan and execute construction by methods to control surface drainage from cuts and fills, from borrow and waste disposal areas. Prevent erosion and sedimentation.
- B. Minimize the amount of bare soil exposed at one time.
- C. Provide temporary measures such as berms, dikes, and drains, to prevent water flow.

- D. Construct the fill and waste areas by selective placement to avoid erosive surface silts or clays.
- E. Periodically inspect the earthwork to detect evidence of erosion and sedimentation; promptly apply corrective measures.

1.25 NOISE CONTROL

- A. Provide methods, means, and facilities to minimize noise produced by the construction operations.
- B. Restrictions on Noise:
 - 1. Use equipment with well-maintained mufflers.
 - 2. Use the least noisy techniques practical.
 - 3. Schedule noisy activities when ambient background noise level is highest.
 - 4. Turn off all unneeded and idling equipment and engines.
 - 5. Locate noise sources as far as practical from noise sensitive locations.
 - 6. Orient noise sources away from noise sensitive locations

1.26 PEST CONTROL

- A. Provide methods, means, and facilities to prevent pests and insects from damaging the Work, or entering the facility.

1.27 POLLUTION CONTROL

- A. Provide methods, means, and facilities to prevent the contamination of soil, water, and the atmosphere from discharge of noxious, toxic substances, and pollutants produced by the construction operations.

1.28 RODENT CONTROL

- A. Provide methods, means, and facilities to prevent rodents from accessing or invading the premises.

1.29 REMOVAL OF UTILITIES, FACILITIES, AND CONTROLS

- A. Remove temporary utilities, equipment, facilities, and materials prior to Substantial Completion.
- B. Remove the underground installations to a minimum depth of 2 feet. Grade the site as indicated.
- C. Clean and repair the damage caused by installation or use of temporary work.
- D. Restore the existing facilities used during construction to the original condition. Restore the permanent facilities used during construction to the specified condition.

PART-2 - PRODUCTS

Not Used.

PART 3 - EXECUTION

Not Used.

END OF SECTION

THIS PAGE INTENTIONALLY LEFT BLANK

SECTION 01 60 00

PRODUCT REQUIREMENTS

PART 1 - GENERAL

1.01 SECTION INCLUDES

- A. Products.
- B. Product delivery requirements.
- C. Product storage and handling requirements.
- D. Product options.
- E. Product substitution procedures.

1.02 PRODUCTS

- A. Products: Means new material, machinery, components, fixtures, or systems forming the Work; but does not include the machinery or equipment used for the preparation, fabrication, conveying, or erection of the Work. Products may include the existing materials or components required or specified for reuse.
- B. Furnish products of qualified manufacturers suitable for the intended use. Furnish products of each type by a single manufacturer unless specified otherwise.
- C. Do not use materials and equipment removed from the existing premises, except as specifically permitted by the Contract Documents.
- D. Furnish interchangeable components of the same manufacturer for the components being replaced.

1.03 PRODUCT DELIVERY REQUIREMENTS

- A. Transport and handle products in accordance with the manufacturer's instructions.
- B. Promptly inspect shipments to ensure that the products comply with the requirements, the quantities are correct, and the products are undamaged.
- C. Provide equipment and personnel to handle the products by methods to prevent soiling, disfigurement, or damage.

1.04 PRODUCT STORAGE AND HANDLING REQUIREMENTS

- A. Store and protect the products in accordance with the manufacturers' instructions.
- B. Store with seals and labels intact and legible.

- C. Store sensitive products in weather tight, climate controlled, enclosures in an environment favorable to the product.
- D. For exterior storage of fabricated products, place on sloped supports above the ground.
- E. Provide bonded off-site storage and protection when the site does not permit on-site storage or protection.
- F. Cover products subject to deterioration with impervious sheet covering. Provide ventilation to prevent the condensation and degradation of products.
- G. Store loose granular materials on solid flat surfaces in a well-drained area. Prevent mixing with foreign matter.
- H. Provide equipment and personnel to store the products by methods to prevent soiling, disfigurement, or damage.
- I. Arrange storage of the products to permit access for inspection. Periodically inspect to verify that the products are undamaged and are maintained in acceptable condition.

1.05 PRODUCT OPTIONS

- A. Products Specified by Reference Standards or by Description Only:
Any Product meeting those standards or description.
- B. Products Specified by Naming One or More Manufacturers with a Provision for Substitutions:
Submit a request for substitution for any manufacturer not named in accordance with the following article.
- C. Products Specified by Naming Three or More Manufacturers with No Substitutions:
Products of one of the manufacturers listed and meeting the specifications, no options or substitutions allowed.

1.06 PRODUCT SUBSTITUTION PROCEDURES

- A. Throughout these Specifications, types of materials may be specified by manufacturer's name, and product information in order to establish standards of quality and performance and not for the purpose of limiting competition.
- B. Inclusion of additional names of manufacturers, other than the Basis of Design manufacturer, does not imply acceptability of standard products from those manufacturers listed. All manufacturers listed shall conform, with modification as necessary, to criteria established by the specification for performance, efficiency, materials, finishes and special accessories along with, at a minimum, matching the Basis of Design product.
- C. No substitutions will be considered prior to receipt of Bids unless written request for approval (by hard copy or email) has been received by the Architect at least 10 calendar days prior to the Bid due date. If the product substitution is approved prior to receipt of the Bids, such approval will be set forth in an Addendum. Bidders shall not rely upon approvals announced in any other manner.

It will be the Architect's and Owner's option to consider a formal request, review and acceptance of a product substitution following award of the contract. For all requests made after award of the contract, the Architect will review the requests with reasonable promptness and notify the Contractor in writing of the decision to accept or reject the substitution.

- D. A request for substitution of any manufacturer or product not named in a specification section is to be submitted in accordance with the following.
1. Document each request with complete data substantiating the compliance of a proposed Substitution with the Contract Documents.
 2. A request constitutes a representation that the Contractor:
 - a. Has investigated the proposed product and determined that it is equal to or superior in all respects to the specified product.
 - b. Will provide the same warranty for the substitution as for the specified product.
 - c. Will coordinate the installation and make changes to other Work that may be required for the Work to be complete with no additional cost to the Owner.
 - d. Waives claims for additional costs or time extension that may subsequently become apparent.
 - e. Will coordinate installation with all affected trade Contractors, specialty Contractors and the like and will be responsible for any and all costs which may arise as a result of this substitution.
 - f. Will reimburse the Owner and the Architect for review or redesign services associated with re-approval by the authorities having jurisdiction.
- E. Substitutions will not be reviewed when a substitution is implied on the Shop Drawing or Product Data submittals without a separate written request or when acceptance will require revision to the Contract Documents.
- F. If the Contractor proposes to use a material which, while suitable for the intended use, deviates in any way from the detailed requirements of the Contract Documents, the Contractor shall inform the Architect in writing of the nature of such deviations at the time the material is submitted for review.
- G. Substitution Submittal Procedure:
1. Submit the Request for Substitution letter, Shop Drawings, Product Data, direct comparison table and the certified test results attesting to the proposed product equivalence by E-mail via an electronic format (PDF) copy to the Architect. Assemble package into a single indexed file incorporating all the required information.
 2. The Contractor shall submit a separate request for each product substitution.
 3. Provide direct comparison between the specified product and the proposed substitution. The burden of proof is on the proposer.
Supporting data to be submitted to permit a fair evaluation of the proposed substitution must address:
 - a. Performance;
 - b. Capacity;
 - c. Efficiency;
 - d. Safety;
 - e. Function;
 - f. Appearance;
 - g. Quality and durability;

- h. Finish;
 - i. Warranty terms and conditions;
 - j. Directly compare, side-by side, in table format, all listed testing agency performance requirements;
 - k. Delivery times and effect on schedules, if any;
 - l. Changes in space requirements or effect on other elements of work, if any;
 - m. Availability of maintenance service and source of replacement materials, if applicable.
- H. The Contract Documents are intended to produce a building of consistent character and quality of design. All components of the building including visible items of mechanical and electrical equipment have been selected to have a coordinated design in relation to the overall appearance of the building. The Architect shall judge the design and appearance of proposed substitutes on the basis of their suitability in relation to the overall design of the Project, as well as for their intrinsic merits. The Architect will not approve as equal to materials specified proposed substitutes which, in the Architect's opinion, would be out of character, obtrusive, or otherwise inconsistent with the character or quality of design of the Project. In order to permit coordinated design of color and finishes the Contractor shall, if required by the Architect, furnish the substituted material in any color, finish, texture, or pattern which would have been available from the manufacturer originally specified, at no additional cost to the Owner.

PART 2 - PRODUCTS

Not Used.

PART 3 - EXECUTION

Not Used.

END OF SECTION

SECTION 01 70 00

EXECUTION REQUIREMENTS

PART 1 – GENERAL

1.01 SECTION INCLUDES

- A. Examination.
- B. Preparation.
- C. Field Engineering.
- D. Protection of adjacent construction.
- E. Cutting and patching.
- F. Special procedures.
- G. Progress cleaning and waste removal.
- H. Final cleaning.
- I. Starting and adjusting of systems.
- J. Demonstration and Instructions.
- K. Testing and adjusting.
- L. Protecting Installed Construction.

1.02 EXAMINATION

- A. Acceptance of Conditions:
 - 1. Verify that the existing applicable site conditions, substrates, or substrate surfaces are acceptable or meet the specific requirements of the individual specifications Sections, for subsequent Work to proceed.
 - 2. Verify that the existing substrate is capable of structural support or attachment of new Work being applied or attached.
 - 3. Examine and verify specific conditions described in the individual specifications Sections.
 - 4. Verify that utility services are available, of the correct characteristics, and in the correct locations.
 - 5. Beginning of new Work, that relies upon the quality and proper execution of the Work of a preceding trade, means acceptance of that preceding Work as appropriate for the proper execution of subsequent Work.
 - 6. Acceptance of preceding Work that can be shown later to have adversely affected proper performance of new Work may result in removal and repeat performance of all Work involved at no cost to the Owner.

1.03 PREPARATION

- A. Clean substrate surfaces prior to applying the next material or substance.
- B. Seal cracks or openings of the substrate prior to applying the next material or substance.
- C. Apply a manufacturer required or recommended substrate primer, sealer, or conditioner prior to applying any new material or substance in contact or bond.
- D. Prior to the application, installation, or erection of any products and product components, perform any other preparatory operations, or surface or substrate modifications, as may be specified or directed by the product manufacturers.

1.04 FIELD ENGINEERING

- A. Employ a Land Surveyor registered in the State of Rhode Island and acceptable to the Architect and the Owner. Locate and protect the survey control and reference points. Promptly notify the Architect of any discrepancies discovered.
- B. Control Datum for the survey is that established by the Owner provided survey, shown on the Drawings
- C. Verify setbacks and easements, if any; confirm the drawing dimensions and elevations.
- D. Provide field engineering services. Establish elevations, lines, and levels, utilizing recognized engineering survey practices.
- E. Submit a copy of the site drawings and certificate signed by the Land Surveyor that the elevations and locations of the Work are in conformance with the Contract Documents.
- F. Maintain a complete and accurate log of the control and survey work as it progresses.
- G. Protect the survey control points prior to starting the site work; preserve the permanent reference point during construction.
- H. Promptly report to the Architect the loss or destruction of any reference point or relocation required because of changes in grades or other reasons.
- I. Replace the dislocated survey control point based on the original survey control. Make no changes without prior written notice to the Architect.
- J. If required by the Owner, on completion of the foundation walls and major site improvements, prepare a certified survey illustrating the dimensions, locations, angles, and elevations of the construction and site work.

1.05 PROTECTION OF ADJACENT CONSTRUCTION

- A. Protect the existing adjacent properties and provide special protection where specified in the individual Specification Sections.

- B. Provide protective coverings at wall, projections, jambs, sills, and soffits of the existing openings.
- C. Protect the existing finished floors, stairs, and other existing surfaces from traffic, dirt, wear, damage, or movement of heavy objects, by protecting with durable sheet materials.
- D. Repair adjacent properties damaged by the construction operations to the original condition to the satisfaction of the Owner.
- E. Prohibit unnecessary traffic from the existing landscaped areas.
- F. Restore the grassed landscaped areas damaged by the construction operations to a full healthy growth by installing loam and sod.

1.06 CUTTING AND PATCHING

- A. Employ the original, or skilled and experienced installer to perform cutting and patching.
- B. Submit a written request in advance of the cutting or altering elements which affect:
 - 1. Structural integrity of element.
 - 2. Integrity of weather-exposed or moisture-resistant elements.
 - 3. Efficiency, maintenance, or safety of the element.
 - 4. Visual qualities of sight-exposed elements.
 - 5. Existing construction, or the Work of separate contractor.
- C. Execute cutting, fitting, and patching including excavation and fill, to complete the Work, and to:
 - 1. Fit the several parts together, to integrate with the other Work.
 - 2. Uncover Work to install or correct ill-timed Work.
 - 3. Remove and replace defective and non-conforming Work.
 - 4. Remove samples of installed Work for testing.
 - 5. Provide openings in the elements of Work for penetrations of mechanical and electrical Work.
- D. Execute Work by methods that will avoid damage to other Work, and provide proper surfaces to receive patching and finishing.
- E. Cut masonry, concrete, and other rigid materials using a masonry saw or core drill.
- F. Restore the Work with new Products in accordance with the requirements of Contract Documents.
- G. Fit Work tight to the pipes, sleeves, ducts, conduits, and other penetrations through surfaces.
- H. Maintain the integrity of the wall, ceiling, or floor construction; completely seal voids.
- I. At the penetration of fire rated partition, ceiling, or floor construction completely seal the voids with a fire rated or fire resistant material to the full thickness of the penetrated element as required to equal the rating of the surrounding construction.
- J. Refinish surfaces to match the adjacent finishes. For continuous surfaces refinish to nearest intersection; for an assembly refinish the entire unit.

1.07 SPECIAL PROCEDURES

- A. Materials: As specified in the product Sections; match the existing with new products, or salvaged products as appropriate, for patching and extending work.
- B. Employ a skilled and experienced installer to perform alteration work.
- C. Cut, move, or remove items as necessary for access to the alterations and renovation Work. Replace and restore at completion.
- D. Remove unsuitable material not marked for salvage, such as rotted wood, corroded metals, and deteriorated masonry and concrete. Replace the materials as specified for finished Work.
- E. Remove the debris and abandoned items from the area and from concealed spaces.
- F. Prepare the surface and remove surface finishes to provide the installation of new Work and finishes,
- G. Close the openings in exterior surfaces to protect the existing Work from the weather and extremes of temperature and humidity.
- H. Remove, cut, and patch the Work in a manner to minimize damage and to provide a means of restoring products and finishes to the original or specified condition.
- I. Where new Work abuts or aligns with the existing, provide a smooth and even transition. Patch the Work to match the existing adjacent Work in texture and appearance.
- J. When finished surfaces are cut so that a smooth transition with the new Work is not possible, terminate the existing surface along a straight line at a natural line of division and submit a recommendation to the Architect for review.
- K. Where a change of plane of 1/4 inch or more occurs, submit a recommendation for providing a smooth transition to the Architect for review.
- L. Patch or replace the portions of existing surfaces which are damaged, or showing other imperfections.
- M. Finish surfaces as specified in the individual product Sections or as indicated on the Drawings.

1.08 PROGRESS CLEANING AND WASTE REMOVAL

- A. Maintain areas free of waste materials, debris, and rubbish. Maintain the site in a clean and orderly condition.
- B. Remove the debris and rubbish from pipe chases, plenums, attics, crawl spaces, and other closed or remote spaces, prior to enclosing the space.
- C. Sweep and vacuum clean the interior areas prior to the start of surface finishing, and continue cleaning to eliminate dust.

- D. Collect and remove the waste materials, debris, and rubbish from the site periodically or weekly and dispose of off-site.
- E. Open free-fall chutes are not permitted. Terminate closed chutes into appropriate containers with lids.

1.09 FINAL CLEANING

- A. Execute final cleaning of areas affected by the Work prior to the final project assessment.
- B. Clean the interior and exterior glass surfaces exposed to view; remove temporary labels, stains and foreign substances, polish transparent and glossy surfaces, vacuum carpeted and soft surfaces.
- C. Clean the equipment and fixtures to a sanitary condition using cleaning materials appropriate to the surface and material being cleaned.
- D. Clean or replace filters of operating equipment as directed by the Architect.
- E. Clean the debris from roofs, gutters, downspouts, and drainage systems.
- F. Clean the site; sweep the paved areas, rake clean the landscaped surfaces.
- G. Remove the waste and surplus materials, rubbish, and the construction facilities from the site.

1.10 STARTING AND ADJUSTING OF SYSTEMS

- A. Coordinate the schedule for the starting and adjusting of various equipment and systems.
- B. Notify the Architect and the Owner seven days prior to the starting and adjusting of each item.
- C. Verify that each piece of equipment or system has been checked for the proper lubrication, drive rotation, belt tension, control sequence, or other conditions which may cause damage.
- D. Verify that the tests, meter readings and the specified electrical characteristics agree with those required by the equipment or system manufacturer.
- E. Verify wiring and support components for equipment are complete and tested.
- F. Execute the starting and adjusting under the supervision of the responsible Contractor's personnel or manufacturer's representative, in accordance with the manufacturer's instructions.
- G. Adjust the operating Products and equipment to ensure smooth and unhindered operation.
- H. When specified in the individual specifications Section, require the manufacturer to provide the authorized representative to be present at the site to inspect, check, and approve the equipment or system installation prior to starting, and to supervise the placing of equipment or system in operation.
- I. Submit a written report in accordance with Section 01 43 00 that the equipment or system has been properly installed and is functioning correctly.

1.11 DEMONSTRATION AND INSTRUCTIONS

- A. Demonstrate the operation and maintenance of Products to the Owner's personnel two weeks prior to the date of Substantial Completion.
- B. For equipment or systems requiring seasonal operation, perform a demonstration for the other season within six months.
- C. Utilize the operation and maintenance manuals as the basis for instruction. Review the manuals with the Owner's personnel in detail to explain all aspects of the operation and maintenance.
- D. Demonstrate the start-up, operation, control, adjustment, trouble shooting, servicing, maintenance, and shutdown of each item of equipment at a scheduled or agreed upon time, at the equipment or system location.
- E. Prepare and insert additional data in the operations and maintenance manuals when the need for additional data becomes apparent during the instruction.

1.12 TESTING, ADJUSTING, AND BALANCING

- A. Submit, for the Owner's approval, the name of an independent firm to perform testing, adjusting, and balancing. The independent firm's services will be paid for by a Change Order from the testing and inspection allowance specified in Section 01 21 00.
- B. The independent firm will perform the services specified in the individual specifications Sections.
- C. Reports will be submitted by the independent firm to the Architect and the Owner indicating the observations and test results, indicating the compliance or non-compliance with the specified requirements and with the requirements of the Contract Documents.

1.13 PROTECTING INSTALLED CONSTRUCTION

- A. Protect the installed Work and provide special protection where specified in the individual specification sections.
- B. Provide temporary and removable protection for the installed products. Control activity in the immediate work area to prevent damage.
- C. Provide protective coverings at walls, projections, jambs, sills, and soffits of openings.
- D. Protect finished floors, stairs, and other surfaces from traffic, dirt, wear, damage, or movement of heavy objects, by protecting with durable sheet materials.
- E. Repair or replace the installed Work damaged by construction operations, as directed by the Architect.

PART 2 - PRODUCTS

Not Used.

PART 3 - EXECUTION
Not Used.

END OF SECTION

THIS PAGE INTENTIONALLY LEFT BLANK

SECTION 01 74 19

WASTE MATERIALS MANAGEMENT AND RECYCLING

PART 1 GENERAL

1.01 RELATED DOCUMENTS:

- A. Drawings and general provisions of each prime Contract, including General and Supplementary Conditions and other Division 1 Specification Sections, apply to this Section.

1.02 WASTE MANAGEMENT GOALS FOR THE PROJECT

- A. The Owner has established that this Project shall generate the least amount of waste possible and that processes shall be employed that ensure the generation of as little waste as feasible including prevention of damage due to mishandling, improper storage, contamination, inadequate protection or other factors as well as minimizing overall packaging and poor quantity estimating.
- B. Of the inevitable waste that is generated, the waste materials designated in this specification shall be salvaged for reuse or recycling. Waste disposal in landfills or incinerators shall be minimized. On new construction projects this means careful recycling of job site waste, on demolition projects this also means careful removal for salvage.

1.03 SUMMARY:

- A. This Section includes required salvage and recycling of the following waste materials and applies to all such listed waste materials produced during the course of this Contract:
 - 1. Land Clearing Debris: Solid waste generated solely from land clearing operations, such as stumps and trees.
 - a. See Division 31 "Site Clearing" section for requirements for salvage and processing of designated materials to produce mulch for use in landscape construction for this project. Material required for production of landscape mulch is not classified as "land clearing debris."
 - 2. Concrete, Masonry, and Other Inert Fill Material: Concrete, brick, rock, clean soil not intended for other on-site use, broken up asphalt pavement containing no ABC stone, clay, concrete, or other contaminants, and other inert material.
 - 3. Metals: Metal scrap including iron, steel, copper, brass, and aluminum.
 - 4. Untreated Wood: Unpainted, untreated dimensional lumber, plywood, oriented strand board, masonite, particleboard, and wood shipping pallets.
 - 5. Gypsum Wallboard Scrap: Excess drywall construction materials including cuttings, other scrap, and excess materials.
 - 6. Cardboard: Clean, corrugated cardboard such as used for packaging, etc.
 - 7. Paper: Discarded office refuse such as unwanted files, correspondence, etc.
 - 8. Plastic Buckets: Containers for various liquid and semi-solid or viscous construction materials and compounds.
 - 9. Beverage Containers: Aluminum, glass, and plastic containers.
 - 10. Other Mixed Construction and Demolition Waste: Solid waste resulting solely from construction, remodeling, repair, or demolition operations on pavement, buildings, or other structures exclusive of waste materials listed herewith.

11. Materials to be salvaged if possible:
 - a. Dimensioned Lumber and Heavy Timbers.
 - b. Wood siding.
 - c. Structural Steel.
 - d. Wood Paneling, molding, trim and Wainscoting.
 - e. Insulation.
 - f. Brick and block.
 - g. Electric Equipment and Light Fixtures.
 - h. Plumbing fixtures and brass.
 - i. Windows, doors and frames.
 - j. Hardwood flooring.

- B. Non-Recyclable Waste: Collect and segregate non-recyclable waste for delivery to a permitted landfill site.
 1. Mixed Solid Waste: Solid waste usually collected as a municipal service, exclusive of waste materials listed above.

1.04 HAZARDOUS MATERIAL SUSPICION

- A. If, during the course of construction, the Contractor suspects a material to contain asbestos, all work involving the material is to be stopped and the Architect notified immediately of the suspicion. Until the material is confirmed to be safe or tested and determined to be an asbestos containing material, the Contractor is to assume it contains asbestos and is to avoid contact. Upon notification of its composition the Architect will determine the course of action and inform the Contractor accordingly.

1.05 DEFINITIONS:

- A. Waste Materials are defined as large and small pieces of the materials indicated which are excess to the contract requirements and generally include materials which are to be salvaged from existing construction and items of trimmings, cuttings and damaged goods resulting from new installations, which can not be effectively used in the Work.

1.06 SUBMITTALS:

- A. Construction Waste Management Plan: Before start of construction, submit for the approval of the Architect a construction waste management plan indicating how Contractor proposes to collect, segregate, and dispose of all construction wastes and debris produced by the work of this Contract. Show compliance with regulations specified under "Quality Assurance" article below. Include a list of recycling facilities to which indicated recyclable materials will be distributed for disposal. Identify materials that are not recyclable or otherwise conservable that must be disposed of in a landfill or other means acceptable under governing State and local regulations. List permitted landfills and/or other disposal means to be employed. Indicate any instances where compliance with requirements of this specification does not appear to be possible and request resolution from the Architect.
- B. Delivery Receipts: Provide to the Construction Quality Manager delivery receipts for waste materials salvaged and sent to permitted waste materials processors or recyclers within 48 hours of delivery that indicate the location and name of firm accepting recyclable waste materials, types of

materials, net weights of each type, date of delivery and value of materials. Hazardous weights are not to be included.

- C. Application for Payments: The Contractor shall submit with each Application for Payment a summary of waste materials, recycled, salvaged and disposed of using a form generated by the Contractor and approved by the Architect. Failure to submit this information shall render the Application for Payment incomplete and shall delay Payment. The Summary shall contain the following information: For each material salvaged and recycled from the Project, include the amount (in cubic yards or tons or in the case of salvaged items state quantities by number, type and size of items) and the destination (i.e. recycling facility, used building materials yard). For each material land filled or incinerated from the Project, include the amount (in cubic yards or tons) of material and the identity of the landfill, incinerator or transfer station.

1.07 QUALITY ASSURANCE:

- A. Regulatory Requirements: Comply with all applicable requirements of the federal, state or local authorities concerning Management of Construction, Demolition, Land Clearing, Inert, and Yard Trash Debris
- B. Disposal Sites, Recyclers, and Waste Materials Processors: Use only facilities properly permitted by the State and by local authorities where applicable.
- C. Pre-Construction Waste Management Conference: Prior to beginning work at the site, schedule and conduct a conference to review the Construction Waste Management Plan and discuss procedures, schedules and specific requirements for waste materials recycling and disposal. Discuss coordination and interface between the Contractor and other construction activities. Identify and resolve problems with compliance with requirements.
 - 1. Attendees: The Contractor and related Contractor personnel associated with the work of this section, including personnel to be in charge of the waste management program; Owner, and the Architect.
 - 2. Plan Revision: Make any revisions to the Construction Waste Management Plan agreed upon during the meeting and incorporate resolutions agreed to be made subsequent to the meeting. Submit the revised plan to the Architect for approval.
- D. Implementation: Designate an on-site party responsible for instructing workers and implementing the Construction Waste Management Plan. Distribute copies of the Construction Waste Management Plan to the job site foreman and each subcontractor. Include waste management and recycling in worker orientation. Provide on-site instruction on appropriate separation, handling, recycling, and salvaging methods to be used by all parties at the appropriate stages of the work at the site. Include waste management and recycling discussion in pre-fabrication meetings with subcontractors and fabricators. Also include discussion of waste management and recycling in regular job meetings and job safety meetings conducted during the course of work at the site.

1.08 STORAGE AND HANDLING:

- A. Site Storage: Remove all indicated recyclable materials from the work location to approved containers daily. Failure to remove waste materials will be considered cause for withholding payment and termination of Contract.

- B. Position covered containers for recyclable waste materials at a designated location on the Project Site. Select a location for the recyclable materials containers separated from that of general waste and rubbish containers. Provide separate collection containers for a minimum of the following materials:
 - 1. Untreated lumber.
 - 2. Gypsum wallboard.
 - 3. Paper, paper products, and cardboard.
 - 4. Plastics.
 - 5. Metals.
 - 6. Glass.
 - 7. Other salvageable materials.
- C. Change out loaded containers for empty ones as demand requires, but not less than weekly.
- D. Handling: Deposit all indicated recyclable materials in the containers in a clean (no mud, adhesives, solvents, petroleum contamination), debris-free condition. Do not deposit contaminated materials into the containers until such time as such materials have been cleaned.
- E. If the contamination chemically combines with the material so that it can not be cleaned, do not deposit into the recycle containers. Comply disposal with all legal and regulatory requirements.

1.09 PROJECT/SITE CONDITIONS:

- A. Environmental Requirements: Transport recyclable waste materials from the Work Area to the recycle containers and carefully deposit in the containers without excess noise and interference with other activities, in a manner to minimize noise and dust. Reclose container covers immediately after materials are deposited.
 - 1. Do not place recyclable waste materials on the ground adjacent to a container.
- B. Existing Conditions: Coordinate with "Instructions to Bidders" and "Supplementary Conditions".

PART 2 PRODUCTS (Not Used)

PART 3 EXECUTION

3.1 WASTE MANAGEMENT:

- A. General: Implement waste management procedures in accordance with approved construction waste management plan. Maintain procedure throughout the life of this Contract.
- B. Source Separation: Separate, store, protect, and handle at the project site all identified recyclable and salvageable waste products to prevent contamination of materials and maximize recyclability and salvageability of materials.
- C. Arrange for the regular collection, transport from the site, and delivery to respective approved recycling centers of indicated recyclable waste materials. Maintain records accessible to the Architect for verification of construction waste materials recycling.
- D. Delivery Receipts: Arrange for timely pickups from the site or deliveries to approved recycling facilities of designated waste materials to keep construction site clear and prevent contamination of

recyclable materials. Keep and maintain records of all deliveries to recycling facilities and all pickups of waste materials at the site by others as specified above.

3.2 RECYCLABLE WASTE MATERIALS HANDLING:

- A. General: The following paragraphs supplement handling requirements for various materials identified for classification and recycling listed in Part 1 "Summary" article above.
- B. Paper: Classify and handle waste paper goods as follows:
1. Bond Paper: As generally found in the construction offices and used for specifications, correspondence, copiers, printers and FAX machines. Collect in a separate container at each workstation and deposit loose in the appropriate recycle container daily.
 2. Newsprint: Newspapers and tabloid style advertising. Collect in a single location and deposit daily in the appropriate recycle container.
 3. Prints (drawings): Set up a single location for collection. Roll together to minimize space. Deposit daily in the appropriate recycle container.
- C. Packaging materials:
1. Cardboard and paperboard cartons and boxes: Knock-down, fold flat and deposit in the appropriate recycle container.
 2. Paper packing materials (separators, stiffeners, etc.) shall be placed in the same container.
 3. Newsprint, used as packing (shredded or whole), shall be deposited in the recyclable container for newsprint.
 4. Plastic (polystyrene peanuts and other shapes) shall be deposited in the recyclable container for plastics.
 5. Metal and plastic banding materials shall be deposited in the appropriate container.
- D. Metals: Cut all items to lengths and sizes to fit within the container provided, when necessary. Where there is sufficient quantity of a specific recyclable waste item (for example; salvaged metal roofing or duct work), make special arrangements for items to be bundled, banded or tied, and stack in a designated location for a special pick-up. Coordinate all special arrangements with the Architect.
- E. Plastics: Collect recyclable plastics (polystyrene and others specifically marked for recycling) daily from work areas and deposit in designated containers.
- F. Glass: Remove waste glass products (sheet, bottles, etc.) daily from the work area and deposit in designated containers. Where glass containers are marked for separation by color or type, segregate glass accordingly. Glass containing imbedded wire (typical in some fire rated doors having glazed lights) is not recyclable.
- G. Gypsum Wallboard: Separate gypsum wallboard from other wastes. Dispose of waste gypsum wallboard off-site at a gypsum reclamation or recycling facility, or on-site as a soil amendment.
1. For on-site application as a soil amendment, incorporate waste gypsum wallboard in landscape areas under construction, at a rate of 50 pounds per 1000 square feet, or approximately one ton per acre.
 - a. Material must be unpainted gypsum wallboard from new construction, ground to reduce material to a fine particle size (70% passing a 100 mesh screen), and must be fully incorporated into the soil surface.

- H. Other Items: Where recyclability classification of any given waste material is unclear, verify with the Architect.

END OF SECTION

SECTION 01 78 00

CLOSEOUT SUBMITTALS

PART 1 - GENERAL

1.01 SECTION INCLUDES

- A. Closeout procedures.
- B. Quality assurance.
- C. Maintenance service.
- D. Owner's Manuals
- E. Operations and maintenance manuals.
- F. Materials and finishes manuals.
- G. Equipment and systems manuals
- H. Spare parts and maintenance materials.
- I. Product warranties and product bonds.
- J. Project Record documents.
- K. Project close out inspections – Punch List

1.02 CLOSEOUT PROCEDURES

- A. Submit a written certification that the Contract Documents have been reviewed, the Work has been inspected, and that the Work is complete in accordance with the Contract Documents and is ready for the Architect's review.
- B. Provide submittals to Architect that are required by the governing or other authorities, including the following closeout documents:
 - 1. AIA Document G706 - Contractor's Affidavit of Payment of Debts and Claims, 1994 Edition.
 - 2. AIA Document G706A - Contractor's Affidavit of Release of Liens, 1994 Edition.
 - 3. AIA Document G707 - Consent of Surety to Final payment, 1994 Edition.
- C. Submit final Application for Payment identifying total adjusted Contract Sum, previous payments, and sum remaining due.
- D. The Owner will occupy all portions of the building as specified in Section 01 10 00.

1.03 QUALITY ASSURANCE

- A. Employ personnel assembling submittals experienced in the maintenance and the operation of the described products and systems.

1.04 MAINTENANCE SERVICE

- A. Submit a contract for furnishing service and maintenance of the components indicated in the specification Sections for one year from date of Substantial Completion, or during the warranty period, whichever period of time is the longest.
- B. Provide for an examination of the system components at a frequency consistent with reliable operation. Clean, adjust, and lubricate as required.
- C. Include a systematic cleaning, examination, adjustment, and lubrication of the components. Repair or replace the parts whenever required. Use the parts produced by the manufacturer of the original component.
- D. Do not assign or transfer the maintenance service to an agent or Subcontractor without the prior written consent of the Owner.

1.05 OWNER'S MANUALS

- A. Submit the data for Operations and Maintenance, Materials and Finishes, and Equipment and Systems Manuals bound in 8-1/2 x 11 inch text pages, in maximum 2 inch size, D side three - ring commercial quality binders with durable cleanable plastic covers.
- B. Prepare binder covers with the printed title of the manual, title of the project, and the subject matter of binder when multiple binders are required.
- C. Internally subdivide the binder contents with permanent page dividers, logically organized as described below; with tab titling clearly printed under reinforced laminated plastic tabs.
- D. Drawings: Provide with reinforced punched binder tab. Bind in with the text; fold the larger drawings to the size of the text pages.
- E. Submit one copy of the completed volumes for review. They will be reviewed and returned with the Architect's comments. Revise the content of the manuals as required prior to final submission.
- F. Submit one set of revised final volumes in final form.
- G. Submit one copy of all the manuals for Operations and Maintenance, Materials and Finishes, and Equipment and Systems in PDF electronic format on a Compact Disc or DVD.

1.06 OPERATIONS AND MAINTENANCE MANUALS

- A. Contents: Prepare the Table of Contents for each volume, with each product or system description identified, typed on white paper, in three parts as follows:
 - 1. Part 1: Directory, listing the names, addresses, and telephone numbers of the Architect, Contractor, Subcontractors, and major equipment suppliers.
 - 2. Part 2: Operation and maintenance instructions, arranged by system and subdivided by the specification Section. For each category, identify the names, addresses, and telephone numbers of the Subcontractors and suppliers. Identify the following:
 - a. Significant design criteria.
 - b. List of equipment.
 - c. Parts list for each component.
 - d. Operating instructions.
 - e. Maintenance instructions for equipment and systems.
 - f. Maintenance instructions for special finishes, including recommended cleaning methods and materials, and special precautions identifying detrimental agents.
 - 3. Part 3: Project documents and certificates, including the following:
 - a. Shop drawings and product data.
 - b. Air and water balance reports.
 - c. Certificates.
 - d. Photocopies of warranties and bonds.
 - e. MSDS for applicable products.

1.07 MATERIALS AND FINISHES MANUALS

- A. Instruction for Care and Maintenance: include manufacturer's instructions for cleaning agents and methods, precautions against detrimental agents and methods, and a recommended schedule for cleaning and maintenance.
- B. Moisture Protection and Weather Exposed Products: Include product data listing applicable reference standards, chemical composition, and details of installation. Include recommendations for inspections, maintenance, and repair.
- C. Include Material Safety Data Sheets (MSDS) for all applicable products. These are required to provide both workers and emergency personnel with the proper procedures for handling or working with a particular substance. MSDS's include information such as physical data (melting point, boiling point, flash point etc.), toxicity, health effects, first aid, reactivity, storage, disposal, protective equipment, and spill/leak procedures.
- D. Additional Requirements: As specified in the individual product specification Sections.
- E. Include a listing in the Table of Contents for design data, with a tabbed flysheet and a space for the insertion of data.

1.08 EQUIPMENT AND SYSTEMS MANUALS

- A. For equipment, or component parts of equipment put into service during construction and operated by the Owner, submit documents within 10 days after acceptance.
- B. Each Item of Equipment and Each System: Include a description of the unit or system, and the component parts. Identify the function, normal operating characteristics, and limiting conditions. Include performance curves, with engineering data and tests, and complete nomenclature and model number of replaceable parts.
- C. Panelboard Circuit Directories: Provide electrical service characteristics, controls, and communications; by label machine.
- D. Include color-coded wiring diagrams as installed.
- E. Operating Procedures: Include start-up, break-in, and routine normal operating instructions and sequences. Include regulation, control, stopping, shutdown, and emergency instructions. Include summer, winter, and special operating instructions.
- F. Maintenance Requirements: Include routine procedures and guide for preventative maintenance and troubleshooting; disassembly, repair, and reassembly instructions; and alignment, adjusting, balancing, and checking instructions.
- G. Include a servicing and lubricating schedule, and a list of lubricants required.
- H. Include the manufacturer's printed operation and maintenance instructions.
- I. Include sequence of operation by the controls manufacturer.
- J. Include the original manufacturer's parts list, illustrations, assembly drawings, and diagrams required for maintenance.
- K. Include control diagrams by the controls manufacturer as installed.
- L. Include the Contractor's coordination drawings, with color-coded piping diagrams as installed.
- M. Include charts of valve tag numbers, with the location and function of each valve, keyed to the flow and control diagrams.
- N. Include a list of the original manufacturer's spare parts, current prices, and recommended quantities to be maintained in storage.
- O. Include test and balancing reports.
- P. Additional Requirements: As specified in the individual product specification Sections.
- Q. Include a listing in the Table of Contents.

1.09 SPARE PARTS AND MAINTENANCE PRODUCTS

- A. Furnish spare parts, maintenance, and extra products in the quantities specified in the individual specification Sections.
- B. Deliver to the Project site and place in a location as directed by the Owner; obtain a receipt prior to final payment.

1.10 PRODUCT WARRANTIES AND PRODUCT BONDS

- A. Obtain warranties and bonds executed in duplicate by the responsible subcontractors, suppliers, and manufacturers, within 10 days after the completion of the applicable item of work.
- B. Execute and assemble the transferable warranty documents and bonds from the subcontractors, suppliers, and manufacturers.
- C. Verify that the documents are in the proper form, contain full information, and are notarized.
- D. Co-execute the submittals when required.
- E. Submit two copies in D side three ring binders with a durable plastic cover.
- F. Submit prior to the final Application for Payment.
- G. Time of Submittals:
 - 1. For equipment or component parts of equipment put into service during construction with the Owner's permission, submit the documents within 10 days after acceptance.
 - 2. Make other submittals within 10 days after the Date of Substantial Completion, prior to the final Application for Payment.
 - 3. For items of Work for which acceptance is delayed beyond the Date of Substantial Completion, submit within 10 days after acceptance, listing the date of acceptance as the beginning of the warranty or bond period.

1.11 PROJECT RECORD DOCUMENTS

- A. Maintain on the site one set of the following record documents; record actual revisions of the Work for all trades:
 - 1. Construction drawings.
 - 2. Specifications.
 - 3. Addenda.
 - 4. Change Orders and other modifications to the Contract.
 - 5. Reviewed Shop Drawings, Product Data, and Samples.
 - 6. Manufacturer's instructions for assembly, installation, and adjusting.
- B. Ensure the entries are complete and accurate, enabling future reference by the Owner.
- C. Store the record documents separate from the documents used for construction.
- D. Record information concurrent with the construction progress, not less than weekly.

- E. Specifications: Legibly mark and record at each product Section description of the actual products installed, including the following:
 - 1. Manufacturer's name and product model and number.
 - 2. Product substitutions or alternates utilized.
 - 3. Changes made by Addenda and modifications.

- F. Construction Record Drawings and Shop Drawings: Legibly mark each item to record the actual construction including:
 - 1. Measured depths of foundations in relation to the first floor datum.
 - 2. Measured horizontal and vertical locations of the underground utilities and appurtenances, referenced to permanent surface improvements.
 - 3. Measured locations of internal utilities and appurtenances concealed in the construction.
 - 4. Field changes of dimension and detail.
 - 5. Details not on the original contract construction drawings.

- G. Legibly marked Specifications, and legibly marked Record Construction Drawings and Shop Drawings shall constitute the Project Record Documents.

- H. Update the on-site Project Record Documents on a regular basis. Monthly payments will not be processed if Project Record Documents are not maintained up to date.

- I. At completion of the Work of the Contract, the Architect will furnish the Contractor with an electronic copy of the construction drawings in AutoCad or Autodesk Revit format, and the Project Manual content in Adobe Acrobat PDF format.

- J. Transfer the information from the Project Record Documents onto the electronic documents (Drawings in AutoCad or Autodesk Revit format and the Project Manual in Adobe Acrobat PDF format copied onto CD or DVD ROM disc. These documents will constitute the As-Built Documents. Deliver the As-Built Documents to the Architect as two copies on paper and two USB Flash drives. The two paper copies are to be bound and printed full size. Also deliver the paper Project Record Documents to the Architect.

- K. The Architect will review the As-Built Documents and compare them with the Project Record Documents for accuracy, and if necessary return them to the Contractor for final correction. At the time of final submission of the As-Built documents, submit the final Application for Payment.

- L. No review or receipt of record of As-Built Documents by the Architect or the Owner shall be interpreted as a waiver of any deviation from the Contract Documents or Shop Drawings , or in any way relieve the Contractor from responsibility to perform the Work in accordance with the Contract Documents and the Shop Drawings to the extent they are in accordance with the Contract Documents

1.12 PROJECT CLOSE OUT INSPECTIONS - PUNCH LIST

- A. When the work has reached such a point of completion that the building or buildings, equipment, apparatus or phase of construction or any part thereof required by the Owner for occupancy or use can be so occupied and used for the purpose intended, the Contractor, prior to notification to the Architect, shall make a preliminary inspection of the Work to insure that all requirements of the Contract have been met and the Work is substantially complete and is acceptable.

Upon such notification, the Owner or the Architect and the consulting Engineers shall make detailed inspection of the Work to insure that all requirements of the Contract have been met and the Work is complete and is acceptable.

- B. Within ten (10) calendar days of notification, the Architect and the consulting Engineers will perform the inspection and a copy of the report of the inspection shall be furnished to the Contractor so that the Contractor may proceed without delay with any part of the Work found to be incomplete or defective. The Contractor shall complete the items listed within thirty (30) calendar days and notify the Owner and Architect
- C. When the items appearing on the report of inspection have been completed or corrected, the contractor shall so advise the Owner and the Architect. After receipt of this notification, the Owner or the Architect and consulting Engineers shall reinspect and inform the Contractor of any remaining items.

A copy of the report of the final inspection containing all remaining contract exceptions, omissions and incompletions shall be furnished to the Contractor within seven (7) calendar days of notification.

- D. The Contractor shall within fourteen (14) calendar days complete the items listed on the inspection report and provide notification of completion and all remaining contract exception, omissions and incompletions from the Contractor, the Owner and the Architect and consulting Engineers will reinspect the Work to verify completion of the exception items appearing on the report of final inspection.

Upon completion of reinspections, the Architect will prepare a certificate of final acceptance or will furnish to the Contractor a copy of the report of the Architect's reinspection detailing Work that is incomplete or obligations that have been fulfilled but are required for final acceptance.

The Contractor shall compensate the Architect and all consulting Engineers for services performed on Punch List inspections beyond the original inspection and two reinspections of the same area through a credit change order reducing the total contract amount.

- E. Upon Substantial Completion of the Work, the Contractor will be paid all retainage, less one hundred fifty percent (150%) of the value attributable to "punch list" work. As items on the punch list are completed, the Contractor will be paid one hundred fifty percent (150%) of their value at the next progress payment.

PART 2 - PRODUCTS

Not used.

PART 3 - EXECUTION

Not used.

END OF SECTION

THIS PAGE INTENTIONALLY LEFT BLANK

SECTION 01 81 13

ENVIRONMENTAL GOALS FOR THE PROJECT

PART 1 - GENERAL

1.01 ENVIRONMENTAL GOALS FOR THE PROJECT

- A. This project, being a major facility of a Rhode Island public agency is required per Chapter 37-24 of the Rhode Island General Laws to meet the R.I. Green Building Act that states that a new building, addition or renovation is to be designed and constructed to at least the LEED certified or an equivalent high performance green building standard.
- B. Overall project goals: The Owner has established the following environmental goals for the Project. These goals are general in nature; refer to specific specification sections for more detailed requirements. Notify Owner and Architect if conflicts arise between performance of the work and environmental goals. This specification is not intended to limit alternative means of achieving these goals. Suggestions and input from the Contractor for implementing these goals are encouraged.
1. Use resources efficiently—the construction, operation, and ultimately reuse or removal of the building should be optimized to eliminate unnecessary use of energy, water, and raw materials. As such, the building has been designed to:
 - a. Require a minimum of nonrenewable energy.
 - b. Require a minimum amount of water.
 - c. Support occupant efforts to recycle and reuse materials.
 - d. Be durable consistent with expected current and future uses.
 - e. Utilize materials and construction methods that require a minimum of energy, water, and raw materials.
 - f. Be reusable and/or recyclable in whole or in component parts.
 2. Provide a healthy and productive indoor environment—to the extent that the building can affect their experience, occupants should be enlivened, relaxed, and stimulated when they are in the building. To this end, the building has been designed to:
 - a. Minimize the potential for water accumulation in conditions in which mold and mildew can flourish.
 - b. Utilize daylight as a primary source of illumination, while minimizing glare and extreme contrast.
 - c. Provide optimal amounts of clean, fresh air to occupied spaces.
 - d. Release a minimum of unhealthy pollutants from building components, fixtures, and furnishings.
 - e. Evacuate effectively any pollutants generated by occupant activities in the building.
 - f. Provide views and experiences of nature.
 - g. Provide an aural environment that is relaxing and supportive.
 3. Enhance, restore, and protect the site—the insertion of the building into the site should support and enhance the natural systems on and around the affected area. To this end, the building, infrastructure, and landscaping have been designed to:
 - a. Support and utilize natural water flow patterns and minimize the need for intrusive stormwater management systems.
 - b. Support native plants and the habitat they create for beneficial insects, birds, and animals.
 - c. Minimize the release of harmful emissions into the soil, water, and air.
 4. Enhance, restore, and protect the global environment—the building is designed to minimize releases of pollutants that affect the global environment and to avoid the need for materials that are polluting to manufacture. These measures include:

- a. Minimizing the release of carbon dioxide (CO₂) from fuels burned on site or fuels burned off site to supply electricity to the building
 - b. Avoiding the release of ozone-depleting compounds, such as HCFCs from refrigerants or foam insulation materials
 - c. Selection of building materials that, based on an overall life-cycle assessment, are the least damaging to the environment in their extraction, processing, use, and ultimate disposal
- C. Material selection and construction process goals: In support of the overall goals listed above, the following goals have been identified for the material selection and construction process. These are also general in nature and should be considered as a guideline—in the event of a conflict, any specific requirements in technical specification sections take precedence. Tradeoffs and compromises are inevitable in the pursuit of these goals, but everyone working on the project is expected to take all reasonable actions to further these goals. Notify Owner and Architect of any performance requirements that conflict unnecessarily with these goals.
1. Use resources efficiently:
 - a. Select materials that use resources efficiently.
 - b. Use construction practices that achieve the most efficient use of resources and materials.
 - c. Recycle or reuse job-site waste.
 - d. Select recycled-content materials.
 - e. Select materials that can be recycled.
 2. Avoid scarce, irreplaceable, or endangered resources:
 - a. Select materials from abundant, well-managed resources.
 - b. Select materials that are replaceable, renewable, or can be replenished.
 - c. Select materials that minimize damage to natural habitats.
 3. Use durable materials:
 - a. Select materials with the longest usable life.
 - b. Select materials that can be reused.
 - c. Select materials with the least burdensome maintenance requirements.
 4. Create spaces that are healthy for occupants:
 - a. Select low-toxic products and materials.
 - b. Select materials without toxic maintenance requirements.
 - c. Specify mechanical equipment that will provide fresh air and will not trap water or pollutants.
 5. Use energy efficiently:
 - a. Select materials with low embodied energy.
 - b. Select materials that save energy during building operations.
 - c. Select products and equipment that save energy during building operations.
 6. Use water efficiently:
 - a. Use construction practices that achieve the most efficient use of water.
 - b. Select water-conserving appliances and equipment.
 - c. Landscape for water conservation.
 - d. Capture and utilize rainwater.
 7. Select materials that generate the least amount of pollution. Consider pollution and toxins generated during harvesting, mining, manufacturing, transport, installation, use, and disposal.
 8. Protect/restore natural habitats.

1.02 ENVIRONMENTAL GOALS IMPLEMENTATION

- A. Contractor shall designate an on-site party (or parties) responsible for instructing workers and overseeing the Environmental Goals for the Project.

- B. Distribution: The Contractor shall distribute copies of the Environmental Goals to the Job-Site Foreman, and each Subcontractor.
- C. Meetings: Environmental Goals shall be discussed at the following meetings:
1. Pre-bid meeting
 2. Pre-construction meeting
 3. Regular job-site meetings

PART 2 - PRODUCTS

Not Used.

PART 3 - EXECUTION

Not Used.

END OF SECTION

THIS PAGE INTENTIONALLY LEFT BLANK

SECTION 01 81 14

ENVIRONMENTAL IMPACT OF MATERIALS

PART 1 - GENERAL

1.01 RELATED DOCUMENTS:

- A. Drawings and general provisions of Contract, including General and Supplementary Conditions and other Division-1 Specification sections, apply to this section.

1.02 WORK INCLUDED:

- A. Objectives: To obtain acceptable Indoor Air Quality (IAQ) for the completed project and minimize the environmental impacts of the construction and operation, the Contractor during the construction phase of this project shall implement the following procedures singly or in combination:
 - 1. Select products that minimize consumption of non-renewable resources, consume reduced amounts of energy and minimize amounts of pollution to produce, and employ recycled and/or recyclable materials. Obtain Architect's approval of all materials listed in Part 2 prior to placing the order with the manufacturer of the material.
 - 2. Maintain a materials log book and verification that materials used have been reviewed for environmental considerations as outlined in this section.
 - 3. Control sources of potential IAQ pollutants by controlled selection of materials and processes used in project construction in order to attain acceptable IAQ as defined in this section.
- B. Products and processes that achieve the above objectives to the extent currently possible and practical have been selected and shown in the Contract Documents. The Contractor is responsible to maintain and support these objectives in developing means and methods for performing the work of this Contract and in proposing product substitutions and/or changes to specified processes.

1.03 RELATED WORK:

- A. Division 1 sections: "Indoor Air Quality Requirements", and "Waste Materials Management and Recycling".

1.04 SUBMITTALS:

- A. Submit the following in accordance with Conditions of the Contract and Division 1 specification sections.
 - 1. Submit as part of the Division 1 Project Closeout documents indicating for each material the VOC content, the recycled content, and the Manufacturer's Safety Data Sheet (MSDS).

1.05 QUALITY ASSURANCE:

- A. As part of the Preconstruction Meeting specified in Division 1 discuss the IAQ and environmental impact compliances required by this Contract. The purpose of this agenda item is to develop a mutual understanding of the IAQ and environmental impact program requirements, and coordination of the Contractor's management of the program with the Architect.

PART 2 - PRODUCTS

2.01 MATERIALS:

- A. General: The following special IAQ and environmental impact requirements apply to materials specified in their respective technical specification sections of this Project Manual. See Tables 2.1 and 2.2 for definitions of low VOC content and recycled content.

The following list are qualities requested to be attained to the best ability of the Contractor for each of the described materials in the pursuit to achieve a more environmentally compatible building.

- B. Division 03 - Concrete:
1. Cast-in-Place Concrete:
 - a. Reinforcing steel shall maximize recycled scrap steel content.
 - b. Form release agents shall be low VOC content.
 - c. Liquid membrane-forming curing and sealing compound shall be low VOC content.
 2. Structural Precast Concrete:
 - a. Form release agent shall be low VOC content.
 - b. Reinforcing bars shall maximize recycled steel content.
 3. Architectural Precast Concrete:
 - a. Form release agent shall be low VOC content.
 - b. Reinforcing bars shall maximize recycled steel content.
- C. Division 04 - Masonry:
1. Concrete Unit Masonry:
 - a. Concrete Unit Masonry shall maximize the use of recycled materials.
 - b. Reinforcing bars shall maximize the use of recycled steel.
- D. Division 05 - Metals:
1. Structural Steel: Framing steel shall maximize the use of recycled steel.
 2. Ornamental Handrails and Railings: Wood cap originates from a sustainably managed forest certified by Scientific Certification Systems (SCS) or other independent forest management certification agency.
- E. Division 06 - Wood and Plastics: Wood products:
1. Each specified solid and veneer wood species must originate from a sustainably managed forest certified by a Forest Stewardship Council (FSC) accredited certification group such as Smartwood or Scientific Certification Systems (SCS).
 2. Fiberboard used as blocking, millwork, casework substrate, underlay and door cores must be urea-formaldehyde free, and not exceed ANSI A208.1-1993 emission standard of 0.20 ppm of formaldehyde.
 3. Structural fiberboard (OSB, MDF, and particleboard) shall maximize post-consumer waste material.
 4. Plastic laminates will be installed with water-based, formaldehyde free, low VOC (volatile organic compound) adhesives.
 5. Millwork and casework adhesives will be water-based, formaldehyde free, low VOC adhesives.
 6. Transparent wood finish systems shall utilize only waterborne acrylic sealers and finish coats.

- F. Division 06 - Wood and Plastics:
 - 1. Cast Resin Countertops: Silicone sealants shall be water-based low VOC silicone sealant.

- G. Division 07 - Thermal and Moisture Protection:
 - 1. Building Insulation:
 - a. Insulation materials manufactured using chlorofluorocarbons (CFCs) shall not be used. (CFCs have been completely phased out of U. S. manufactured insulation products.)
 - b. Extruded polystyrene insulation shall not be manufactured with chlorofluorocarbon (CFC) blowing agent and shall maximize recycled content.
 - c. Fiberglass batt insulation, fiberglass board insulation, and mineral wool insulation shall maximize use of recycled material.
 - d. Mineral wool fire safing insulation shall maximize recycled material.
 - 2. Single-Ply Membrane Roofing: Rigid insulation manufactured with chlorofluorocarbon (CFC) blowing agents shall not be used.
 - 3. Joint Sealants:
 - a. Interior sealants shall not contain: mercury, butyl rubber, neoprene, SBR (styrene butadiene rubber), or nitrile.
 - b. Silicone sealants shall be low VOC content.
 - c. Polyurethane sealants containing mercury shall not be used.
 - d. Compressible foam joint fillers, polyester polyurethane foam impregnated with neoprene rubber or acrylic ester styrene copolymer used in this facility shall not be manufactured with CFC blowing agents.
 - e. Sealants formulated with aromatic solvents (organic solvent with a benzene ring in its molecular structure) fibrous talc or asbestos, formaldehyde, halogenated solvents, mercury, lead, cadmium, hexavalent chromium, or their components shall not be used.

- H. Division 08 - Doors and Windows:
 - 1. Flush Wood Doors: Fiberboard used as door cores shall meet the requirements of ANSI A208.1-1993 for particleboard, including the requirement to meet a threshold of less than 0.30 ppm of formaldehyde using test method ASTM 1333.
 - 2. Glass and Glazing:
 - a. Sealants and glazing compounds shall be low VOC content.
 - b. Sealants and glazing compounds formulated with aromatic solvents (organic solvent with a benzene ring in its molecular structure), fibrous talc or asbestos, formaldehyde, halogenated solvents, mercury, lead, cadmium, hexavalent chromium, or their components will not be used.

- I. Division 09 - Finishes:
 - 1. Gypsum Drywall:
 - a. Gypsum board must contain recycled or synthetic gypsum. Facing paper shall be manufactured from recycled newsprint including post-consumer waste.
 - b. Glass fiber sound attenuation blanket insulation shall maximize recycled material.
 - c. Joint compound shall be low VOC content.
 - d. Multi-layer gypsum board applications shall be screw attached and not laminated with adhesives.
 - e. Provide for thorough cleaning and removal of all silica/gypsum dust upon completion of gypsum drywall installations, including, but not necessarily limited

- to, all components in plenum spaces, including tops of pipes and sills, and insides and outsides of ducts (as required in Division 23).
- f. Only paper joint tape (no fiberglass tape) will be used.
 - g. Mineral fiber sound attenuation blankets shall maximize recovered material.
 - h. Steel studs, runners, and channels for framing shall maximize recycled steel content.
- 2. Acoustic Panel Ceilings:
 - a. Ceiling panels shall maximize use of recycled material, and be finished with water-based low VOC paint.
 - b. Suspension systems shall maximize recycled material.
 - 3. Resilient Tile Flooring:
 - a. Rubber floor tiles shall maximize recycled materials.
 - b. Adhesives shall be low VOC content.
 - 4. Sheet Vinyl Floor Covering: Sheet vinyl floor covering shall be installed with water-based, low VOC adhesives per manufacturer's instructions.
 - 5. Carpet/Carpet Tile:
 - a. Carpet shall be one that is accepted in an operating recycling program which extracts component materials for reuse and/or reclaims inherent energy, and does not contribute significantly to land fill.
 - b. If an adhesive is required for installation, use low VOC carpet manufacturer recommended adhesive and install per manufacturer's recommended frame or perimeter adhesive pattern method. (Full field glue-down is not acceptable except for carpet with an integral dry film adhesive back.)
 - c. If a seam sealer is required for installation, use carpet manufacturer recommended low VOC seam sealer or recommend heat welded seaming.
 - 6. Paint and Polychromatic Finish Coating:
 - a. Do not use water based paints formulated with aromatic hydrocarbons (organic solvent with a benzene ring in its molecular structure), formaldehyde, halogenated solvents, mercury or mercury compounds, or tinted with pigments of lead, cadmium, chromium VI and their oxides. Water based paints shall be low VOC and shall have a flash point of 61 degrees C or greater.
 - b. Where it is necessary to use solvent-based paints, they shall be formulated for low VOC emissions and shall not be formulated with formaldehyde, halogenated solvents, mercury or mercury compounds, or tinted with pigments of lead, cadmium, chromium VI and their oxides, nor formulated with more than 10% aromatic hydrocarbons by weight.
 - c. The following shall be low VOC and not be formulated with aromatic hydrocarbons (organic solvent with a benzene ring in its molecular structure) formaldehyde, halogenated solvents, mercury or mercury compounds, or tinted with pigments of lead, cadmium, chromium VI and their oxides.
 - High performance water based acrylic coatings.
 - Pigmented acrylic sealers.
 - Catalyzed epoxy coatings.
 - High performance silicone grafted epoxy coatings.
- J. Division 12 - Furnishings:
 - 1. Casework: Silicone sealant shall be water-based silicone sealant with low VOC content.
 - K. Division 21, 22 & 23 – Fire Protection, Plumbing & Mechanical:
 - 1. Basic Mechanical Materials and Methods: Use low VOC joint sealers.

2. Basic Piping Materials and Methods: Use solder that does not contain lead.
 3. Underground Utilities - Basic Piping Materials and Methods: Use solder that does not contain lead.
 4. Pipes and Pipe Fittings: Use solder that does not contain lead.
 5. Mechanical Insulation: Mechanical sound insulation materials within the duct shall include a impervious, non-porous coating that prevents dust from accumulating in the insulating materials.
 6. Plumbing Fixtures: Plumbing fixtures must meet water conservation requirements of the Energy Policy Act.
 7. Metal Ductwork: Use low VOC joint and seam sealants.
- L. Division 31 – Earthwork & 32 - Exterior Improvements:
1. Site Clearing: Topsoil shall be provided by the Contractor from on-site material which has been stockpiled for re-use. Off-site borrow should only be used when on-site sources are exhausted.
 2. Aggregate Base Course: Aggregate base course for on-site paved areas shall maximize use of recycled ABC.
 3. Asphaltic Concrete Paving: Asphalt paving shall maximize use of recycled asphalt paving.
 4. Site Potable Water Lines; No solder will be used with lead content.
 5. Landscaping:
 - a. All wood fiber or cellulose hydromulch shall be 100% recovered content.
 - b. All herbicides must be EPA approved and applied per manufacturer's instructions. All herbicide use must be approved by the Architect.

Table 2.1 Definition of Low VOC Content Levels

<u>Material or Product</u>	<u>Low VOC Content Level</u>
Form Release Agents	350 g/L VOC content
Plastic Laminate Adhesive	20 g/L VOC content
Casework and Millwork Adhesives	20 g/L VOC content
Transparent Wood Finish Systems	350 g/L VOC content
Cast Resin Countertop silicone Sealant	20 g/L VOC content
Water based Joint Sealants	50 g/L VOC content
Non-water based Joint Sealants	350 g/L VOC content
Portland Cement Plaster	20 g/L VOC content
Gypsum Drywall Joint Compound	20 g/L VOC content
Acoustic Panel Ceiling Finish	50 g/L VOC content
Resilient Tile Flooring Adhesive	100 g/L VOC content
Vinyl Flooring Adhesives	100 g/L VOC content
Carpet Adhesive	50 g/L VOC content
Carpet Seam Sealer	50 g/L VOC content
Water-based Paint & Polychromatic finish coatings	150 g/L VOC content
Solvent -based Paint	380 g/L VOC content
High Performance Water-Based Acrylic coatings	250 g/L VOC content

Pigmented Acrylic Sealers	250 g/L VOC content
Catalyzed Epoxy coatings	250 g/L VOC content
High Performance Silicone	250 g/L VOC content
Casework Sealant	50 g/L VOC content
Liquid membrane-forming curing & sealing compound	350 g/L VOC content

Table 2.2 Required Minimum Recycled Content of Materials

<u>Material or Product</u>	<u>Recommended Recycle Content</u>
Asphaltic Concrete Paving	25% by weight
Reinforcing Steel in Concrete	60% recycled scrap steel 1
Reinforcing Bars in Precast Concrete	60% recycled steel 1
Concrete Unit Masonry	50% recycled content
Reinforcing Bars in Concrete Unit Masonry	60% recycled steel 1
Framing steel	30% recycled steel 1
Mineral wool insulation	75% recycled material (slag) 2
Mineral wool fire safing insulation	75% recycled material by weight (slag) 2
Gypsum board	10% recycled or synthetic gypsum
Facing paper of Gypsum Board	100% recycled newsprint including post consumer waste 2
Mineral Fiber Sound Attenuation Blankets	75% recovered material by weight (slag) 2
Steel studs, runners, and channels	60% recycled steel 1
Steel doors & frames	20% Pre-consumer & 50% Post-consumer Recycled content
Acoustic Panel Ceilings	60% recycled material by weight
Ceiling Suspension Systems	60% recycled material 1
Rubber floor tiles	90-100% recycled materials 2
Hydromulch	100% recovered materials 2
Structural fiberboard	80-100% recycled content 2

Notes for Table 2.2:

1. 60% represents the average recycled content for the U. S. steel industry. Use of U. S. manufactured steel will meet this requirement.
2. As per EPA Comprehensive Guideline for Procurement of Products Containing Recovered Materials (60 FR 21370, effective May 1, 1996).

PART 3 - EXECUTION

3.01 GENERAL:

- A. Submit to the Architect for review and approval product data such as MSDS and environmental impact data prior to ordering project materials.
- B. Prepare and maintain a Materials Log, providing information on content of materials, where specific materials are to be used, MSDS, and environmental specifications of the material. Maintain the log book weekly as materials are ordered.

3.02 FIELD QUALITY CONTROL:

- A. The Owner reserves the right to take samples and perform, at random, tests of approved materials delivered to the job site to verify compliance of actual materials with specifications.

END OF SECTION

THIS PAGE INTENTIONALLY LEFT BLANK

SECTION 01 81 22

INDOOR AIR QUALITY MANAGEMENT
DURING CONSTRUCTION

PART 1- GENERAL

1.01 SUMMARY

- A. IAQ Management during Construction
 - 1. Develop and implement an Indoor Air Quality (IAQ) Management Plan for the construction and pre-occupancy phases of the building as follows:
 - a. During construction meet or exceed the recommended Control Measures of the Sheet Metal and Air Conditioning National Contractors Association (SMACNA) IAQ Guideline for Occupied Buildings under Construction, latest edition, Chapter 3.
 - b. Protect stored on-site or installed absorptive materials from moisture damage.
 - c. Replace all filtration media immediately prior to occupancy with MERV 8 filters or higher.

1.02 OVERVIEW

- A. The intent of this IAQ Plan is to:
 - 1. Minimize exposure of construction workers to air pollutants;
 - 2. Prevent air pollutants from collecting in building systems and on building materials; and
 - 3. Prevent air pollutants caused by construction from migrating into occupied spaces.
- B. For the purposes of this plan, air pollutants are defined as: Particulates, Volatile organic compounds, Formaldehyde, Combustion emissions, Airborne bacteria and micro-organisms and Airborne inorganic compounds, such as ozone (from electric motors), metal fumes (from smoldering and welding), and ammonia and chlorine (from cleaning products).

PART 2- PRODUCTS

Not used

PART 3-EXECUTION

3.01 HVAC EQUIPMENT AND DUCT WORK

- A. HVAC equipment and ductwork will be protected from dust and other pollutants via the following procedures:
 - 1. Sealing Ductwork and Air Handling Equipment
 - a. Openings into installed or existing ductwork and air-handling equipment not in active use will be sealed using taped plastic, taped cardboard, or other reasonably air-tight coverings. Sealing will occur prior to, or immediately upon installation of the new ductwork or equipment. Regular walk-throughs will be conducted by the Contractor to check for damaged or displaced coverings. Repair or replacement of damaged or displaced coverings will occur immediately upon discovery, at the direction of the Contractor.

- b. Construction work that generates air pollution will be avoided where ductwork or air handling equipment is being installed. If visible air pollutants are present in a space where ductwork is to be installed, spot cleaning or other measures will be used to prevent ductwork or equipment contamination.
- 2. Use of Mechanical Systems during Construction
 - a. Exhaust and makeup air supply systems:
When a system is operated during construction, its filters will be replaced upon completion of construction with MERV 13 filters.
 - b. Air handling systems will be subject to these provisions when operated during construction:
 - 1. The AHU will be protected with a temporary filter having a minimum rating of MERV 8, per ASHRAE 52.2.
 - 2. Distribution elements needing filters, including all return air ductwork, will be protected with temporary filters having a minimum rating of MERV 8 per ASHRAE 52.2 unless otherwise noted below.
 - c. All components of the distribution on the return side will be protected, including but not limited to:
 - 1. The portion of the air handler upstream of the central fan;
 - 2. Return vents, ducts and shafts;
 - 3. VAV box intakes; and
 - 4. Transfer ducts.
 - d. Components of the distribution system on the supply side will typically not need protection except if portions of the supply system become contaminated, coarse filters will be applied to completely cover supply outlets, to prevent the distribution of particulates into building spaces.
- 3. Filter Replacement and Tracking
 - a. MERV 8 filters used for ductwork protection will be replaced on an as-needed basis, as determined by the Contractor.
 - b. Upon completion, the MERV 8 filters used for ductwork protection will be discarded. New filters will be installed at all air handlers.

3.02 TEMPORARY LOCAL EXHAUST

- A. Where available, operable vents and windows will be opened to ventilate the building during application of interior finishes when weather conditions are suitable. Spaces with fixed glazing or no windows will be ventilated by localized temporary exhaust, as described below, or by using building mechanical systems (described above).
 - 1. Local temporary exhaust will be accomplished using fans, duct extensions, and filters.
 - 2. Local temporary exhaust will not discharge near air intakes or other openings that lead into the building.

3.03 COVERING OR SEALING SOURCES OF POLLUTION

- A. The following are rules that apply to materials that emit air pollution or odors:
 - 1. Containers containing wet materials will be covered whenever they are not in active use.
 - 2. Waste materials will be covered or sealed and regularly removed from the building.
 - 3. Absorptive materials or materials with an odor will be covered while moved through the building.
 - 4. Whenever possible, material containers will be disposed of with the covers on.
 - 5. Materials that require a surface coating to control pollutants or odors will be coated

promptly.

3.04 CONTROLLING POLLUTION AT ENTRANCES

- A. Measures will be taken to prevent pollutants from being tracked into interior spaces by workers or equipment. These will include temporary walk-off mats and floor protection.

3.05 PROTECTION OF STORED MATERIALS

- A. Measures will be taken to minimize dust accumulation on material surfaces and the absorption of other pollutants by absorbent materials. The measures will include the following:
 1. Materials will be handled and stored according to the manufacturer's recommendations.
 2. Unwrapped absorbent materials will be shrink-wrapped if necessary.
 3. Highly absorbent materials like duct liner, acoustic tile, carpeting, or insulation will be stored indoors in the original packaging, or covered and sealed.
 4. Moderately porous materials like gypsum board will be stored indoors, wrapped or away from dust and materials prone to off-gas VOC's.
 5. Framing lumber will be stored indoors whenever possible. If stored outdoors, the lumber will be covered with a water proof covering, stored off the ground, and located away from standing water.
 6. Dense material like glass, metal framing, ductwork and equipment will be covered and kept dry.
 7. If condensation forms on cold material, care will be taken not to expose it to dust or other particles. If exposed to pollution, housekeeping measures will be used promptly to clean the material before installation.

3.06 PREVENTING CONTAMINATION OF COMPLETED AREAS FROM WORK UNDER CONSTRUCTION

- A. When work is completed in an area, the area will be protected from pollutants generated in other parts of the building still under construction. One or more of the following methods of pathway interruption will be used:
 1. Erecting barriers between completed areas and areas still under construction
 2. Where present, doors and windows will be closed and locked between completed portions of the building and portions of the building still under construction.

3.07 HOUSEKEEPING

- A. The following housekeeping measures will be employed throughout construction:
 1. A regular housekeeping schedule will be instituted. Cleaning measures and frequency will be selected according to the pollutants generated in a space.
 2. Low-odor cleaning agents will be used.
 3. Spills of water or solvent will be cleaned up immediately.
 4. Attention will be given to cleaning hidden or hard-to-reach surfaces, such as wall cavities, tops of door, ledges, and behind water closets.

3.08 SCHEDULING

- A. Construction activities shall be scheduled such that construction and occupancy do not overlap in time. Provide adequate time for carpet, paint and other finishes time to off-gas prior to occupancy.

3.09 BUILDING FLUSH OUT AFTER CONSTRUCTION AND PRIOR TO OCCUPANCY

- A. After construction ends and interior finishes are installed at the end of each Construction Phase, flush-out the air in the building to reduce contaminant concentrations by supplying a total outdoor air volume of 14,000 cubic feet per square foot (ft³/ft²) of occupiable building area. An internal temperature of not less than 60°F and relative humidity not higher than 60 percent shall be maintained during the flush-out process.
The length of time of the flush-out should be for a continuous 24 hours for seven days.

END OF SECTION

SECTION 01 89 00

SITE CONSTRUCTION PERFORMANCE REQUIREMENTS

PART 1 - GENERAL

1.1 DESCRIPTION

- A. This Section specifies the general requirements for the site work included in the Contract.
- B. These requirements supplement those contained in the Standard General Conditions of the Construction Contract and their Supplemental Conditions.
- C. References are included in this Section to Articles of the General Conditions to call the Contractor's attention to frequently needed requirements.

1.2 PERMITS

- A. Unless otherwise provided in the Supplementary Conditions, the Contractor shall obtain and pay for all construction permits and licenses. The Owner shall assist Contractor, when necessary, in obtaining such permits and licenses. The Contractor shall pay all charges and inspection fees necessary for the prosecution of the Work and shall pay all charges of utility owners for connections to the Work unless noted otherwise on the Plans.

1.3 LAWS AND REGULATIONS

- A. Contractor shall give all notices and comply with all laws and regulations applicable to furnishing and performance of the Work.
- B. If the Contractor performs any work that is contrary to laws or regulations, the Contractor shall bear all claims, costs, losses and damages caused by, arising out of or resulting therefrom.

1.4 UTILITIES

- A. Shown or Indicated: The information and data shown or indicated in the Contract Documents with respect to existing underground facilities (utilities) at or contiguous to the site is based on information and data furnished to Owner or Engineer by the owners of such underground facilities (utilities) or by others.
 - 1. The Owner and Engineer shall not be responsible for the accuracy or completeness of any such information or data; and
 - 2. The cost of all of the following will be included in the Contract and Contractor shall have full responsibility for: (i) reviewing and checking all such information and data; (ii) locating all underground facilities (utilities) shown or indicated in the Contract Documents; (iii) coordination of the Work with the owners of such underground facilities (utilities) during construction; and (iv) the safety and protection of all such underground facilities (utilities) and repairing any damage thereto resulting from the Work.

- B. Not Shown or Indicated: If an underground facility (utility) is uncovered or revealed at or contiguous to the site which was not shown or indicated in the Contract Documents, the Contractor shall, promptly after becoming aware thereof and before further disturbing conditions affected thereby or performing any Work in connection therewith (except in an emergency), identify the owner of such underground facility (utility) and give written notice to that facility (utility) owner and to Owner and Engineer. Engineer will promptly review the underground facility (utility) and determine the extent, if any, to which a change is required in the Contract Documents to reflect and document the consequences of the existence of the underground facility (utility). If the Engineer concludes that a change in the Contract Documents is required, revised plans and specifications will be issued to reflect and document such consequences. During such time, the Contractor shall be responsible for the safety and protection of such underground facility (utility). Section 00 00 00 "Title": Item.
- C. Contractor shall notify all municipal agencies and utility companies owning or operating utilities, of proposed work affecting the utilities, or agencies.
- D. Contractor shall give written notification within the time period required by the agency or company for advance notification. A copy of the notification shall be furnished to the Engineer.
- E. Contractor shall notify "DIG SAFE" before commencing any work in the vicinity of existing subsurface utilities.
- F. Contractor shall secure in-place existing utilities whose support is affected by the work and cooperate and assist the agency or company operating the utility in maintaining the utility services. Contractor shall correct any damage to the utilities caused by construction operations by repair or replacement, as required by the utility owner. When the repair or replacement is made by the utility owner, Contractor shall pay all costs assessed by the utility owner for the work.
- G. If the existing utilities are found to conflict with the proposed work, the Contractor shall protect and maintain the utilities and take measurements to determine the location, type and dimensions of the utility. The information shall be furnished to the Engineer who will determine the changes required in the proposed work or existing utilities to resolve the conflict as soon thereafter as is reasonable.
- H. Contractor shall verify the location, size, invert elevation and type of existing facilities at all points of connection prior to ordering new utility materials.

1.5 SOILS INFORMATION

- A. A geotechnical report on site soil conditions has been prepared for the Owner. Refer to Section 31 00 00 — EARTHWORK (SITE) for information about and use of the geotechnical report.
- B. The geotechnical report and the soils data are furnished to Contractor for informational purposes only and are specifically not a part of these Contract Documents. The Owner does not guarantee that the information is representative of all soils, rock, and other materials that may be encountered on the site.

- C. Contractor may make additional subsurface explorations upon written request to, and upon approval by, the Owner at no additional cost to the Owner.

1.6 SOIL SUPPORT

- A. Contractor shall furnish and install excavation soil support devices or use soil strengthening techniques required to perform excavations in accordance with the current requirements of the U.S. Department of Labor, Occupational Health & Safety Administration and all federal, state, and municipal laws and regulations.

1.7 REFERENCE STANDARDS

- A. References are made to technical societies, organizations and groups using the following abbreviations. All work so referred shall conform to the current edition of the referenced standard.

AASHTO American Association of State Highway Transportation Officials

ACI American Concrete Institute

ACOE United States Army Corps of Engineers

AGC Associated General Contractors of America

ANSI American National Standards Institute

AOAC Association of Official Agricultural Chemists

ASTM American Society for Testing and Materials

AWPA American Wood Preservers Association

AWWA American Water Works Association

NEMA National Electrical Manufacturers Association

NEWWA New England Water Works Association

OSHA Occupational Safety and Health Administration

UL Underwriters Laboratory

1.8 TRAFFIC MAINTENANCE

- A. Contractor shall maintain access to the site and through the work zones for personnel and vehicles of emergency services, utility agencies, inspection services, and others authorized to enter, move about and work on the site.

- B. When work is required on public roadways, Contractor shall furnish, install, maintain, and remove all signs, drums, barricades, steel plates, and other devices required by the federal or state government or municipality to maintain and protect pedestrians and vehicular traffic.
- C. Protective measures shall be installed at site access points to prevent mud and other debris from being deposited on the public roadways by construction traffic. The public roadways shall be swept as required to remove any deposits.

1.9 STATE AND LOCAL REFERENCE STANDARDS

- A. Building Code Rhode Island State Building Code
- B. RIDEM Rhode Island Department of Environmental Management
- C. RIDOT Rhode Island Department of Transportation

END OF SECTION 01 89 00

SECTION 01 91 00

GENERAL COMMISSIONING REQUIREMENTS

PART 1 - GENERAL

1.1 DESCRIPTION

- A. Commissioning: Commissioning is a systematic process of ensuring that all building systems perform interactively according to the design intent and the owner's operational needs. This is achieved by beginning in the design phase and documenting design intent and continuing through construction, acceptance and the warranty period with actual verification of performance. The commissioning process shall encompass and coordinate the traditionally separate functions of system documentation, equipment startup, control system calibration, testing and balancing, performance testing and training.

- B. Commissioning during the construction phase is intended to achieve the following specific objectives according to the Contract Documents:
 - 1. Verify that applicable equipment and systems are installed according to the manufacturer's recommendations and to industry accepted minimum standards and that they receive adequate operational checkout by installing contractors.
 - 2. Verify and document proper performance of equipment and systems.
 - 3. Verify that O&M documentation left on site is complete.
 - 4. Verify that the Owner's operating personnel are adequately trained.

- C. The commissioning process does not take away from or reduce the responsibility of the system designers or installing contractors to provide a finished and fully functioning product.

- D. Abbreviations: The following are common abbreviations used in the Specifications and in the Commissioning Plan. Definitions are found in Section 1.6.

- 1. A/E Architect / Engineer
- 2. CA Commissioning Authority
- 3. CC Controls Contractor
- 4. CM Construction Manager
- 5. Cx Commissioning
- 6. EC Electrical Contractor
- 7. FPT Functional Performance Test
- 8. GC General Contractor
- 9. MC Mechanical Contractor
- 10. PC Prefunctional Checklist
- 11. PM Project Manager (Owner)
- 12. TAB Test and Balance Contractor

1.2 COORDINATION

- A. **Commissioning Team:** The members of the commissioning team consist of the Commissioning Authority (CA), the Project Manager (PM), the designated representative of the owner's Construction Management firm (CM), the architect and design engineers (particularly the mechanical engineer), the Mechanical Contractor (MC), the Electrical Contractor (EC), the TAB representative, the Controls Contractor (CC), any other installing subcontractors or suppliers of equipment. If known, the Owner's building or plant operator/engineer is also a member of the commissioning team.
- B. **Management:** The CA is hired by the Owner directly. The CA directs and coordinates the commissioning activities and the reports to the CM/GC and the owner's representative, and is part of the CM team. All members work together to fulfill their contracted responsibilities and meet the objectives of the Contract Documents.
- C. **Scheduling:** The CA will work with the CM and GC according to established protocols to schedule the commissioning activities. The CA will provide sufficient notice to the CM and GC for scheduling commissioning activities. The GC will integrate all commissioning activities into the master schedule. All parties will address scheduling problems and make necessary notifications in a timely manner in order to expedite the commissioning process.
- D. The CA will provide the initial schedule of primary commissioning events at the commissioning scoping meeting. The Commissioning Plan—Construction Phase provides a format for this schedule. As construction progresses more detailed schedules are developed by the CA. The Commissioning Plan also provides a format for detailed schedules.

1.3 COMMISSIONING PROCESS

- A. **Commissioning Plan:** The commissioning plan provides guidance in the execution of the commissioning process. Just after the initial commissioning meeting the CA will update the plan, which is then considered the "final" plan, though it will continue to evolve and expand as the project progresses.
- B. **Commissioning Process:** The following narrative provides a brief overview of the typical commissioning tasks during construction and the general order in which they occur.
 - 1. Commissioning during construction begins with a meeting conducted by the CA where the commissioning process is reviewed with the commissioning team members.
 - 2. Additional meetings will be required throughout construction, scheduled by the CA with necessary parties attending, to plan, scope, coordinate, schedule future activities and resolve problems.
 - 3. Approved Equipment documentation is submitted to the CA during normal submittals, including detailed start-up procedures.
 - 4. The CA works with the Subs, including providing the Subs with pre-functional checklists to be completed, during the startup process.
 - 5. In general, the checkout and performance verification proceeds from simple to complex; from component level to equipment to systems and intersystem levels with pre-functional checklists being completed before functional testing.
 - 6. The Subs, under their own direction, execute and document the pre-functional checklists and perform startup and initial checkout. The CA documents that the checklists and startup were

completed according to the approved plans. This may include the CA witnessing start-up of selected equipment.

7. The CA develops specific equipment and system functional performance test procedures. The Subs review the procedures.
8. The procedures are executed by the Subs, under the direction of, and documented by the CA.
9. Items of non-compliance in material, installation or setup are corrected at the Sub's expense and the system retested.
10. The CA reviews the O&M documentation for completeness.
11. Commissioning is completed before Substantial Completion as directed by the GC/CM in accordance with the project schedule.
12. The CA reviews, comments on, and helps coordinate the training provided by the Subs and verifies that it was completed.
13. Deferred testing is conducted, as specified or required.

1.4 RESPONSIBILITIES

A. All Parties

1. Follow the Commissioning Plan.
2. Attend commissioning meetings and additional meetings, as necessary.

B. Architect (of A/E)

1. Construction and Acceptance Phase

- a. Attend the commissioning meeting and selected commissioning team meetings.
- b. Perform normal submittal review, construction observation, as-built drawing preparation, O&M manual preparation, etc., as contracted.
- c. Provide any design narrative documentation requested by the CA.
- d. Coordinate resolution of system deficiencies identified during commissioning, according to the contract documents.
- e. Prepare and submit final as-built design intent documentation for inclusion in the O&M manuals. Review and approve the O&M manuals.

2. Warranty Period

- a. Coordinate resolution of design non-conformance and design deficiencies identified during warranty-period commissioning.

C. Mechanical and Electrical Designers/Engineers (of the A/E)

1. Construction and Acceptance Phase

1. Perform normal submittal review, construction observation, as-built drawing preparation, etc., as contracted. One site observation should be completed just prior to system startup.
2. Provide any design narrative and sequences documentation requested by the CA. The designers shall assist (along with the contractors) in clarifying the operation and control of commissioned equipment in areas where the specifications, control drawings or equipment documentation is not sufficient for writing detailed testing procedures.
3. Attend commissioning meetings and other selected commissioning team meetings.

4. Participate in the resolution of system deficiencies identified during commissioning, according to the contract documents.
5. Review and approve the O&M manuals.
6. Provide a presentation at one of the training sessions for the Owner's personnel.
7. Review the pre-functional checklists for major pieces of equipment for sufficiency prior to their use.
8. Review the functional test procedure forms for major pieces of equipment for sufficiency prior to their use.

2. Warranty Period

- a. Participate in the resolution of non-compliance, non-conformance and design deficiencies identified during commissioning during warranty-period commissioning.

D. Commissioning Authority (CA)

1. The CA is not responsible for design concept, design criteria, compliance with codes, design or general construction scheduling, cost estimating, or construction management. The CA may assist with problem solving non-conformance or deficiencies, but ultimately that responsibility resides with the general contractor and the A/E. The primary role of the CA is to develop and coordinate the execution of a testing plan, observe and document performance that systems are functioning in accordance with the documented design intent and in accordance with the Contract Documents. The Contractors will provide all tools or the use of tools to start, checkout and functionally test equipment and systems, except for specified testing with portable data-loggers, which shall be supplied and installed by the CA.

2. Construction and Acceptance Phase

- a. Coordinates and directs the commissioning activities in a logical, sequential and efficient manner using consistent protocols and forms, centralized documentation, clear and regular communications and consultations with all necessary parties, frequently updated timelines and schedules and technical expertise.
- b. Coordinate the commissioning work and, with the CM, ensure that commissioning activities are being scheduled into the master schedule.
- c. Update commissioning plan as required.
- d. Plan and conduct a commissioning meeting and other commissioning meetings.
- e. Request and review additional information required to perform commissioning tasks, including O&M materials, contractor start-up and checkout procedures.
- f. Before startup, gather and review the current control sequences and interlocks and work with contractors and design engineers until sufficient clarity has been obtained, in writing, to be able to write detailed testing procedures.
- g. Review approved Contractor submittals applicable to systems being commissioned for compliance with commissioning needs, concurrent with the A/E reviews.
- h. Write and distribute pre-functional tests and checklists.
- i. Perform site visits, as necessary, to observe component and system installations. Attends selected planning and job-site meetings to obtain information on construction progress. Review construction meeting minutes for revisions/substitutions relating to the commissioning process. Assist in resolving any discrepancies. Responsibility for deficiency resolution shall remain that of the A/E and the CM.
- j. Approve pre-functional tests and checklist completion by reviewing pre-functional checklist reports and by selected site observation and spot-checking.

- k. Document systems startup by reviewing completed start-up reports and by selected site observation.
- l. Review TAB execution plan.
- m. Review completed TAB reports and comment as required.
- n. With necessary assistance and review from installing contractors, write the functional performance test procedures for equipment and systems. This may include energy management control system trending, stand-alone data logger monitoring or manual functional testing. Submit to CM for review, and for approval if required.
- o. Analyze any functional performance trend logs and monitoring data to verify performance.
- p. Coordinate with the CM, witness and approve manual functional performance tests performed by installing contractors. CM to coordinate all retesting as necessary until satisfactory performance is achieved.
- q. Maintain a master deficiency and resolution log and a separate testing record. Provide the CM with written progress reports and test results with recommended actions.
- r. Review equipment warranties to ensure that the Owner's responsibilities are clearly defined.
- s. Review contractor training of the Owner's operating personnel for completeness and compliance with the respective contract requirements.
- t. Compile and maintain a commissioning record.
- u. Review O&M manuals as submitted by the contractors for completeness and compliance with the respective contract requirements.
- v. Provide a final commissioning report (as described in this section).
- w. Prepare a standard trend logging package of primary parameters that will provide the operations staff clear indications of system function in order to identify proper system operation and trouble shoot problems. The CA shall also provide any needed information on interpreting the trends.

3. Warranty Period

- a. Coordinate and supervise required seasonal or deferred testing and deficiency corrections.
- b. Return to the site at 10 months into the 12 month warranty period and review with facility staff the current building operation and the condition of outstanding issues related to the original and seasonal commissioning. Also interview facility staff and identify problems or concerns they have operating the building as originally intended. Make suggestions for improvements and for recording these changes in the O&M manuals. Identify areas that may come under warranty or under the original construction contract

E. Construction Manager (CM)

1. Construction and Acceptance Phase

- a. Facilitate the coordination of the commissioning work by the CA, and with the CA, ensure that commissioning activities are being scheduled into the master schedule.
- b. Include the cost of commissioning in the total contract price.
- c. In each purchase order or subcontract written, include requirements for submittal data, O&M data, commissioning tasks and training.
- d. Ensure that all Subs execute their commissioning responsibilities according to the Contract Documents and schedule.
- e. Review and approve the final *Commissioning Plan—Construction Phase*.
- f. Attend a commissioning scoping meeting and other commissioning team meetings.

- g. Perform the normal review of Contractor submittals.
- h. Furnish a copy of all construction documents, addenda, change orders and approved submittals and shop drawings related to commissioned equipment to the CA.
- i. Review and approve the functional performance test procedures submitted by the CA, prior to testing.
- j. When necessary, observe and witness prefunctional checklists, startup and functional testing of selected equipment.
- k. Review commissioning progress and deficiency reports.
- l. Coordinate the resolution of non-compliance and design deficiencies identified in all phases of commissioning.
- m. Sign-off (final approval) on individual commissioning tests as completed and passing. Recommend completion of the commissioning process to the Project Manager.
- n. Oversee and coordinate the preparation of O&M manuals, according to the Contract Documents, including the clarification and updating of the original sequences of operation to as-built conditions.
- o. Coordinate the training of owner personnel.

2. Warranty Period

- a. Assist the CA as necessary in the seasonal or deferred testing and deficiency corrections required by the specifications.

F. Owner's Project Manager (PM)

1. Construction and Acceptance Phase

- a. Manage the contract of the A/E and of the CM.
- b. Arrange for facility operating and maintenance personnel to attend various field commissioning activities and field training sessions according to the Commissioning Plan—Construction Phase.
- c. Provide final approval for the completion of the commissioning work.

2. Warranty Period

- a. Ensure that any seasonal or deferred testing and any deficiency issues are addressed.

G. Subcontractor

1. Construction and Acceptance Phase

- a. Provide all requested submittal data, including detailed start-up procedures and specific responsibilities of the Owner to keep warranties in force.
- b. Provide Start-up and Pretest Checklists Reports
- c. Assist in all pre-functional testing for equipment that the subcontractor is responsible for.
- d. Include all special tools and instruments (only available from vendor, specific to a piece of equipment) required for testing equipment according to these Contract Documents in the base bid price to the Contractor, except for stand-alone data logging equipment that may be used by the CA.
- e. Provide information requested by CA (through the CM) regarding equipment sequence of operation and testing procedures.
- f. Review test procedures created by the CA and comment as necessary.

- g. A representative shall attend commissioning meetings and other necessary meetings scheduled by the CA to facilitate the Cx process.
- h. Resolve deficiencies identified in all phases of commissioning, as directed by the CM in accordance with the Contract Documents, and all applicable codes and standards.
- i. Implement training of owner personnel according to the Contract Documents.
- j. Prepare O&M manuals, according to the Contract Documents, including clarifying and updating the original sequences of operation to as-built conditions.
- k. Provide specific as-built, maintenance, and one-line documentation for the development of the Systems Manual.

2. Warranty Period

- a. Ensure that Subs execute seasonal or deferred functional performance testing, witnessed by the CA, according to the specifications.
- b. Correct deficiencies and make necessary adjustments to O&M manuals and as-built drawings for applicable issues identified in any seasonal testing.

H. Equipment Supplier / Vendor

1. Provide all requested submittal data, including detailed start-up procedures and specific responsibilities of the Owner to keep warranties in force.
2. Provide on site assistance for all pre-functional testing for all equipment with integral packaged controls.
3. Perform equipment start-ups as requested by the responsible contractor, required as part of manufacturer warranty, or required by the Contract Documents.
4. Include all special tools and instruments (only available from vendor, specific to a piece of equipment) required for testing equipment according to these Contract Documents in the base bid price to the Contractor, except for stand-alone datalogging equipment that may be used by the CA.
5. Resolve deficiencies identified in all phases of commissioning, as directed by the CM in accordance with the Contract Documents, and all applicable codes and standards.
6. Furnish all training requirements and materials for owner personnel in accordance with the Contract Documents.
7. Prepare O&M manuals, in accordance with the Contract Documents.
8. Furnish all warranty data in accordance with the Contract Documents

1.5 DEFINITIONS

- A. Acceptance Phase - phase of construction after startup and initial checkout when functional performance tests, O&M documentation review and training occurs.
- B. Approval - acceptance that a piece of equipment or system has been properly installed and is functioning in the tested modes according to the Contract Documents.
- C. Architect / Engineer (A/E) - the prime consultant (architect) and sub-consultants who comprise the design team, generally the HVAC mechanical designer/engineer and the electrical designer/engineer.
- D. Basis of Design - The basis of design is the documentation of the primary thought processes and assumptions behind design decisions that were made to meet the design intent. The basis of design describes the systems, components, conditions and methods chosen to meet the intent. Some reiterating of the design intent may be included.

- E. Commissioning authority (CA) - an independent agent, not otherwise associated with the A/E team members or the Contractor, though he/she may be hired as a subcontractor to them. The CA directs and coordinates the day-to-day commissioning activities. The CA does not take an oversight role like the CM. The CA is part of the Construction Manager (CM) team or shall report directly to the CM.
- F. Commissioning Plan - an overall plan, developed before or after bidding that provides the structure, schedule and coordination planning for the commissioning process.
- G. Contract Documents - the documents binding on parties involved in the construction of this project (drawings, specifications, change orders, amendments, contracts, *Cx Plan*, etc.).
- H. Contractor - the general contractor or authorized representative.
- I. Control system - the central building energy management control system.
- J. Construction Manager (CM) - a) the Owner's representative in the day-to-day activities of construction. In general, the construction management services contractor (CM) is hired by the owner to assist the government in the overall management of the project including supervising and on-site managing authority over a project's construction. The General Contractor reports to the CM. The CM is the Owner's on-site representative.
- K. Datalogging - monitoring flows, currents, status, pressures, etc. of equipment using stand-alone dataloggers separate from the control system.
- L. Deferred Functional Tests - FTs that are performed later, after substantial completion, due to partial occupancy, equipment, seasonal requirements, design or other site conditions that disallow the test from being performed.
- M. Deficiency - a condition in the installation or function of a component, piece of equipment or system that is not in compliance with the Contract Documents (that is, does not perform properly or is not complying with the design intent).
- N. Design Intent - a dynamic document that provides the explanation of the ideas, concepts and criteria that are considered to be very important to the owner. It is initially the outcome of the programming and conceptual design phases.
- O. Design Narrative or Design Documentation - sections of either the Design Intent or Basis of Design.
- P. Factory Testing - testing of equipment on-site or at the factory, by factory personnel, with an Owner's representative present.
- Q. Functional Performance Test (FT) - test of the dynamic function and operation of equipment and systems using manual (direct observation) or monitoring methods. Functional testing is the dynamic testing of systems (rather than just components) under full operation (e.g., the chiller pump is tested interactively with the chiller functions to see if the pump ramps up and down to maintain the differential pressure setpoint). Systems are tested under various modes, such as during low cooling or heating loads, high loads, component failures, unoccupied, varying outside air temperatures, fire alarm, power failure, etc. The systems are run through all the control system's sequences of operation and components are verified to be responding as the sequences state. Traditional air or water test and balancing (TAB) is not functional testing, in the commissioning sense of the word. TAB's primary work is setting up the system flows and pressures as specified, while functional testing is verifying that which has already been set up. The commissioning authority develops the functional test procedures in a sequential written form, coordinates, oversees and documents the actual testing, which is usually performed by the installing contractor or vendor. FTs are performed after prefunctional checklists and startup are complete.

- R. Indirect Indicators - indicators of a response or condition, such as a reading from a control system screen reporting a damper to be 100% closed.
- S. Manual Test - using hand-held instruments, immediate control system readouts or direct observation to verify performance (contrasted to analyzing monitored data taken over time to make the "observation").
- T. Monitoring - the recording of parameters (flow, current, status, pressure, etc.) of equipment operation using dataloggers or the trending capabilities of control systems.
- U. Non-Compliance - see Deficiency.
- V. Non-Conformance - see Deficiency.
- W. Over-written Value - writing over a sensor value in the control system to see the response of a system (e.g., changing the outside air temperature value from 50F to 75F to verify economizer operation). See also "Simulated Signal."
- X. Owner-Contracted Tests - tests paid for by the Owner outside the GC's contract and for which the CA does not oversee. These tests will not be repeated during functional tests if properly documented.
- Y. Phased Commissioning - commissioning that is completed in phases (by floors, for example) due to the size of the structure or other scheduling issues, in order minimize the total construction time.
- Z. Prefunctional Checklist (PC) - a list of items to inspect and elementary component tests to conduct to verify proper installation of equipment, provided by the CA to the Sub. Prefunctional checklists are primarily static inspections and procedures to prepare the equipment or system for initial operation (e.g., belt tension, oil levels OK, labels affixed, gages in place, sensors calibrated, etc.). However, some prefunctional checklist items entail simple testing of the function of a component, a piece of equipment or system (such as measuring the voltage imbalance on a three phase pump motor of a chiller system). The word prefunctional refers to before functional testing. Prefunctional checklists augment and are combined with the manufacturer's start-up checklist. Even without a commissioning process, contractors typically perform some, if not many, of the prefunctional checklist items a commissioning authority will recommend. However, few contractors document in writing the execution of these checklist items. Therefore, for most equipment, the contractors execute the checklists on their own. The commissioning authority only requires that the procedures be documented in writing, and does not witness much of the prefunctional checklisting, except for larger or more critical pieces of equipment.
- AA. Project Manager (PM) - the contracting and managing authority for the owner over the design and/or construction of the project, a staff position.
- BB. Sampling. - Functionally testing only a fraction of the total number of identical or near identical pieces of equipment. Refer to Section 17100, Part 3.6, F for details.
- CC. Seasonal Performance Tests - FT that are deferred until the system(s) will experience conditions closer to their design conditions.
- DD. Simulated Condition - condition that is created for the purpose of testing the response of a system (e.g., applying a hair blower to a space sensor to see the response in a VAV box).
- EE. Simulated Signal - disconnecting a sensor and using a signal generator to send an amperage, resistance or pressure to the transducer and DDC system to simulate a sensor value.
- FF. Specifications - the construction specifications of the Contract Documents.
- GG. Startup - the initial starting or activating of dynamic equipment includes executing prefunctional checklists.
- HH. Subs - the subcontractors to the GC who provide and install building components and systems.

- II. Test Procedures - the step-by-step process, which must be executed to fulfill the test requirements. The CA develops the test procedures.
- JJ. Test Requirements - requirements specifying what modes and functions, etc. shall be tested. The test requirements are not the detailed test procedures. The test requirements are specified in the Contract Documents (Divisions 23, 26, Etc..).
- KK. Trending - monitoring using the building control system.
- LL. Vendor - supplier of equipment.
- MM. Warranty Period - warranty period for entire project, including equipment components. Warranty begins at Substantial Completion and extends for at least one year, unless specifically noted otherwise in the Contract Documents and accepted submittals.

1.6 SYSTEMS TO BE COMMISSIONED

- A. All Energy-related systems will be commissioned in this project.
 - 1. Building Management System
 - 2. Energy Recovery Units
 - 3. Energy Recovery Ventilators
 - 4. Electric Heaters
 - 5. Roof Top Units
 - 6. VRF Systems including Fan Coils, Condensing Units, and Branch Controllers
 - 7. VAV Boxes
 - 8. Split Systems
 - 9. Exhaust Fans
 - 10. Exhaust Hoods

PART 2 - PRODUCTS

2.1 TEST EQUIPMENT

- A. All standard testing equipment required to perform startup and initial checkout and required functional performance testing shall be provided by the Division contractor for the equipment being tested. For example, the mechanical contractor of Division 23 shall ultimately be responsible for all standard testing equipment for the HVAC system and controls system in Division 23, except for equipment specific to and used by TAB in their commissioning responsibilities.
- B. Special equipment, tools and instruments (only available from vendor, specific to a piece of equipment) required for testing equipment, according to these Contract Documents shall be included in the base bid price to the Contractor and left on site, except for stand-alone datalogging equipment that may be used by the CA.
- C. Datalogging equipment and software required to test equipment will be provided by the CA, but shall not become the property of the Owner.
- D. All testing equipment shall be of sufficient quality and accuracy to test and/or measure system performance with the tolerances specified in the Specifications. All equipment shall be calibrated according to the manufacturer's recommended intervals and when dropped or damaged. Calibration tags shall be affixed or certificates readily available.

PART 3 - EXECUTION

3.1 MEETINGS

- A. Kick-off Meeting: The CA will schedule, plan and conduct a commissioning scoping meeting with the entire commissioning team in attendance. Meeting minutes will be distributed to all parties by the CA. Information gathered from this meeting will allow the CA to modify the Commissioning Plan to its “final” version, which will also be distributed to all parties.
- B. Miscellaneous Meetings: Other meetings will be planned and conducted by the CA as construction progresses. These meetings will cover coordination, deficiency resolution and planning issues with particular Subs. The CA will plan these meetings and will minimize unnecessary time being spent by Subs. For large projects, these meetings may be held monthly, until the final 3 months of construction when they may be held as frequently as one per week. It is intended that the Commissioning meeting will be part of or a supplement to regularly scheduled subcontractor construction meetings (to be coordinated through the CM).

3.2 REPORTING

- A. The CA will provide regular reports to the CM and the Owner’s PM with increasing frequency as construction and commissioning progresses. Standard forms (Commissioning Action List) are provided and referenced in the Commissioning Plan.
- B. The CA will regularly communicate with all members of the commissioning team (as directed by the owner and CM), keeping them apprised of commissioning progress and scheduling changes through memos, progress reports, etc.
- C. Testing or review reports and non-conformance and deficiency reports are made regularly with the review and testing as described in later sections.
- D. A final summary report by the CA will be provided to the Owner and CM, focused on the results of the commissioning process (process overview, issues summary, test documents, etc.). All acquired documentation, logs, minutes, reports, deficiency lists, communications, findings, unresolved issues, etc., will be compiled in appendices and provided with the summary report. Pre-functional checklists, functional tests and monitoring reports will not be part of the final report, but will be stored in the Commissioning Record in the O&M manuals.

3.3 SUBMITTALS

- A. The CA will provide the CM with a specific request for the type of submittal documentation the CA requires to facilitate the commissioning work. These requests will be integrated into the normal submittal process and protocol of the construction team. At minimum, the request will include the manufacturer and model number, the manufacturer’s printed installation and detailed start-up procedures, full sequences of operation, O&M data, performance data, any performance test procedures, control drawings and details of owner contracted tests. In addition, the installation and checkout materials that are actually shipped inside the equipment and the actual field checkout sheet forms to be used by the factory or field technicians shall be submitted to the Commissioning authority. All documentation requested by the CA will be included by the Subs in their O&M manual contributions.

- B. The Commissioning authority will review approved submittals related to the commissioned equipment for conformance to the Contract Documents as it relates to the commissioning process, to the functional performance of the equipment and adequacy for developing test procedures. This review is intended primarily to aid in the development of functional testing procedures and only secondarily to verify compliance with equipment specifications. The Commissioning authority will notify the CM, PM or A/E as requested, of items missing or areas that are not in conformance with Contract Documents and which require resubmission.
- C. The CA may request additional design narrative from the A/E and Controls Contractor, depending on the completeness of the design intent documentation and sequences provided with the Specifications.
- D. These submittals to the CA do not constitute compliance for O&M manual documentation. The O&M manuals are the responsibility of the Contractor, though the CA will review them.

3.4 START-UP, PREFUNCTIONAL CHECKLISTS AND INITIAL CHECKOUT

- A. The following procedures apply to all equipment to be commissioned, according to Section 1.6, Systems to be Commissioned. Some systems that are not comprised so much of actual dynamic machinery, e.g., electrical system power quality, may have very simplified PCs and startup.
- B. General: Prefunctional checklists are important to ensure that the equipment and systems are hooked up and operational. It ensures that functional performance testing (in-depth system checkout) may proceed without unnecessary delays. Each piece of equipment receives full prefunctional checkout. No sampling strategies are used. The prefunctional testing for a given system must be successfully completed prior to formal functional performance testing of equipment or subsystems of the given system.
- C. Start-up and Initial Checkout Plan: The appropriate contractor/manufacturer is responsible for developing detailed start-up plans for all equipment. The primary role of the CA in this process is to ensure that there is written documentation that each of the manufacturer-recommended procedures have been completed. Parties responsible for startup in accordance with the contract documents are identified in the commissioning scoping meeting and in the checklist forms. Responsibility for equipment start-up requirements, protocols, and reports shall be that of the appropriate contractor/manufacturer. CM to forward copies of the completed start-up documentation to the CA.
 - 1. The CA adapts, if necessary, the representative prefunctional checklists and procedures from the Contract Document Requirements. These checklists indicate required procedures to be executed as part of startup and initial checkout of the systems and the party responsible for their execution.
 - 2. It is the Contractor's responsibility to provide these checklists and tests. The Contractor determines which trade is responsible for executing and documenting each of the line item tasks and notes that trade on the form. Each form will have more than one trade responsible for its execution.
 - 3. The subcontractor responsible for the purchase of the equipment develops the full start-up plan by combining the manufacturer's detailed start-up and checkout procedures from the O&M manual and the normally used field checkout sheets. The plan will include checklists and procedures with specific boxes or lines for recording and documenting the checking and inspections of each procedure and a summary statement with a signature block at the end of the plan.

4. The full start-up plan could consist of something as simple as:
 - a. The manufacturer's or contractor's installation checklists.
 - b. The manufacturer's standard written start-up procedures copied from the installation manuals with check boxes by each procedure and a signature block added by hand at the end.
 - c. The Control Contractor's Point-to-Point Checkout Sheets.
 - d. The TAB Report (if applicable).
3. The subcontractor submits the full startup plan to the A/E, CM and CA for review.
4. The A/E, CM and CA review the procedures and the format for documenting them, noting any procedures that need to be added.

D. Execution of Prefunctional Checklists and Startup.

1. Prior to startup, the Subs and vendors schedule startup and checkout with the CM. The performance of the prefunctional checklists, startup and checkout are directed and executed by the Sub or vendor. When checking off prefunctional checklists, signatures may be required of other Subs for verification of completion of their work.
2. The Subs and vendors shall execute startup and provide the CA with a signed and dated copy of the completed start-up and prefunctional tests and checklists.
3. Only individuals that have direct knowledge and witnessed that a line item task on the prefunctional checklist was actually performed shall initial or check that item off. It is not acceptable for witnessing supervisors to fill out these forms.

E. Deficiencies, Non-Conformance and Approval in Checklists and Startup.

1. The Subs shall clearly list any outstanding items of the initial start-up and prefunctional procedures that were not completed successfully, at the bottom of the procedures form or on an attached sheet. The procedures form and any outstanding deficiencies are provided to the CA within two days of test completion.
2. The CA reviews the report and submits either a non-compliance report or an approval form to the Sub or CM. The CA shall work with the Subs and vendors through the CM to correct and retest deficiencies or uncompleted items. The installing Subs or vendors shall correct all areas that are deficient or incomplete in the checklists and tests in a timely manner, and shall notify the CM as soon as outstanding items have been corrected and resubmit an updated start-up report and a Statement of Correction on the original non-compliance report. When satisfactorily completed, the CA recommends approval of the execution of the checklists and startup of each system to the CM using a standard form.
3. Items left incomplete, which later cause deficiencies or delays during functional testing may result in back-charges to the responsible party to be determined by the CM. Refer to Part 3.7 herein for details.

3.5 PHASED COMMISSIONING

- A. If the project requires startup and initial checkout to be executed in phases, this phasing will be planned and scheduled in a coordination meeting of the CA, CM, mechanical, TAB and controls contractors. Results will be added to the master and commissioning schedule.

3.6 FUNCTIONAL PERFORMANCE TESTING

- A. This sub-section applies to all commissioning functional testing for all divisions.
- B. Objectives and Scope: The objective of functional performance testing is to demonstrate that each system is operating according to the documented design intent and Contract Documents. Functional testing facilitates bringing the systems from a state of substantial completion to full dynamic operation. Additionally, during the testing process, areas of deficient performance are identified and corrected, improving the operation and functioning of the systems.
- C. In general, each system should be operated through all modes of operation (seasonal, occupied, unoccupied, warm-up, cool-down, part- and full-load) where there is a specified system response. Verifying each sequence in the sequences of operation is required. Proper responses to such modes and conditions as power failure, freeze condition, low oil pressure, no flow, equipment failure, etc. shall also be tested. Specific modes required in this project are specified in the appropriate sections of the Contract Documents.
- D. Development of Test Procedures: Before test procedures are written, the CA shall obtain all requested documentation and a current list of change orders affecting equipment or systems, including an updated points list, program code, control sequences and parameters. Using the testing parameters and requirements the appropriate sections of the Contract Documents, the CA shall develop specific test procedures and forms to verify and document proper operation of each piece of equipment and system. Each Sub or vendor responsible to execute a test shall provide limited assistance to the CA in developing the procedures review (answering questions about equipment, operation, sequences, etc.). Prior to execution, the CA shall provide a copy of the test procedures to the Sub(s) through the CM who shall review the tests for feasibility, safety, equipment and warranty protection. The CA may submit the tests to the A/E for review, if requested. The purpose of any given specific test is to verify and document compliance with the stated criteria of acceptance given on the test form as developed based on the Contract Documents. The test procedure forms developed by the CA shall include (but not be limited to) the following information, if applicable:
1. System and equipment or component name(s)
 2. Equipment location and ID number
 3. Unique test ID number, and reference to unique prefunctional checklist and start-up documentation ID numbers for the piece of equipment
 4. Date
 5. Project name
 6. Participating parties
 7. A copy of the specific sequence of operations or other specified parameters being verified
 8. Formulas used in any calculations
 9. Required pre-test field measurements
 10. Instructions for setting up the test.
 11. Special cautions, alarm limits, etc.
 12. Specific step-by-step procedures to execute the test, in a clear, sequential and repeatable format
 13. Acceptance criteria of proper performance with a Yes / No check box to allow for clearly marking whether or not proper performance of each part of the test was achieved.
 14. A section for comments
 15. Signatures and date block for the CA

E. Test Methods:

1. Functional performance testing and verification may be achieved by: 1) manual testing (persons manipulate the equipment and observe performance); 2) utilizing the control system by implementing a required control action and witnessing the subsequent equipment or system reaction; or 3) monitoring the performance and analyzing the results using the control system's trend log capabilities or by stand-alone data loggers. The CA will determine which method is most appropriate for tests that do not have a method specified.
2. Simulated Conditions: Simulating conditions shall be allowed, though timing the testing to experience actual conditions is encouraged wherever practical.
3. Overwritten Values: Overwriting sensor values to simulate a condition, such as overwriting the outside air temperature reading in a control system to be something other than it really is, shall be allowed, but shall be used with caution and avoided when possible. Such testing methods often can only test a part of a system, as the interactions and responses of other systems will be erroneous or not applicable. Simulating a condition is preferable. e.g., for the above case, by heating the outside air sensor with a hair blower rather than overwriting the value or by altering the appropriate set point to see the desired response. Before simulating conditions or overwriting values, sensors, transducers and devices shall have been calibrated.
4. Simulated Signals: Using a signal generator which creates a simulated signal to test and calibrate transducers and DDC constants is generally recommended over using the sensor to act as the signal generator via simulated conditions or overwritten values.
5. Altering Set points: Rather than overwriting sensor values, and when simulating conditions is difficult, altering set points to test a sequence is acceptable. For example, to see the AC compressor lockout work at an outside air temperature below 55F, when the outside air temperature is above 55F, temporarily change the lockout set point to be 2F above the current outside air temperature.
6. Indirect Indicators: Relying on indirect indicators for responses or performance shall be allowed only after visually and directly verifying and documenting, over the range of the tested parameters, that the indirect readings through the control system represent actual conditions and responses. Much of this verification is completed during prefunctional testing.
7. Setup: Each function and test shall be performed under conditions that simulate actual conditions as close as is practically possible. The Sub executing the test shall provide all necessary materials, system modifications, etc. to produce the necessary flows, pressures, temperatures, etc. necessary to execute the test according to the specified conditions. At completion of the test, the Sub shall return all affected building equipment and systems, due to these temporary modifications, to their pre-test condition.
8. Sampling: Multiple identical pieces of non-life-safety or otherwise non-critical equipment may be functionally tested using a sampling strategy. Significant application differences and significant sequence of operation differences in otherwise identical equipment invalidates their common identity. It is noted that no sampling by Subs is allowed in prefunctional checklist execution. The example below describes a 20% Sampling—10% Failure Rule.
 - a. Randomly test at least 20% of each group of identical equipment. In no case test less than three units in each group. This 20%, or three, constitute the "first sample."
 - b. If 10% of the units in the first sample fail the functional performance tests, test another 20% of the group (the second sample).
 - c. If 10% of the units in the second sample fail, test all remaining units in the whole group.
 - d. If at any point, frequent failures are occurring and testing is becoming more troubleshoot-ing than verification, the CA may stop the testing and notify the CM to require the respon-sible Sub to perform and document a checkout of the remaining units, prior to continuing with functionally testing the remaining units.

- G. Coordination and Scheduling: The Subs shall provide sufficient notice to the CA regarding their completion schedule for the prefunctional checklists and startup of all equipment and systems. The CA will schedule functional tests through the CM. The CA shall direct, witness and document the functional testing of all equipment and systems. The Subs shall execute the tests.
- H. In general, functional testing is conducted after prefunctional testing and startup has been satisfactorily completed. The control system check out/testing required for the TAB work shall be the responsibility of the controls and TAB contractor. The air balancing and water balancing is completed and debugged before functional testing of air-related or water-related equipment or systems. Testing proceeds from components to subsystems to systems. When the proper performance of all interacting individual systems has been achieved, the interface or coordinated responses between systems is checked.
- I. Problem Solving: The CA will recommend solutions to problems found, however the burden of responsibility to solve, correct and retest problems is with the CM, Subs and A/E.

3.7 DOCUMENTATION, NON-CONFORMANCE AND APPROVAL OF TESTS

- A. Documentation: The CA shall witness and document the results of all functional performance tests using the specific procedural forms developed for that purpose. Prior to testing, these forms are provided to the CM for review and approval and to the Subs for review. The CA will include the filled out forms in the final Commissioning report and as a supplement package to the O&M manuals.
- B. Non-Conformance:
 - 1. The CA will record the results of the functional test on the procedure or test form. All deficiencies or non-conformance issues shall be noted and reported to the CM on a standard non-compliance form (Commissioning Action Item List).
 - 2. Corrections of minor deficiencies identified may be made during the tests at the discretion of the CA. In such cases the deficiency and resolution will be documented on the procedure form.
 - 3. Every effort will be made to expedite the testing process and minimize unnecessary delays, while not compromising the integrity of the procedures.
 - 4. As tests progress and a deficiency is identified, the CA discusses the issue with the executing contractor.
 - a. When there is no dispute on the deficiency and the Sub accepts responsibility to correct it:
 - 1) The CA documents the deficiency and the Sub's response and intentions and they go on to another test or sequence. After the day's work, the CA submits the non-compliance reports to the CM for signature, if required. A copy is provided to the Sub and CA. The Sub corrects the deficiency, signs the statement of correction at the bottom of the non-compliance form certifying that the equipment is ready to be retested and sends it back to the CA.
 - 2) The CA reschedules the test and the test is repeated (Reference 3.7, B.5 below).
 - b. If there is a dispute about a deficiency, regarding whether it is a deficiency or who is responsible:

- 1) The deficiency shall be documented on the non-compliance form with the Sub's response and a copy given to the CM.
 - 2) Resolutions are made at the lowest management level possible. Other parties are brought into the discussions as needed. Final interpretive authority is with the A/E. Final acceptance authority is with the Owner's Project Manager and CM.
 - 3) The CA documents the resolution process.
 - 4) Once the interpretation and resolution have been decided, the appropriate party corrects the deficiency, signs the statement of correction on the non-compliance form and provides it to the CA, through the CM. The CA reschedules the test and the test is repeated until satisfactory performance is achieved.
5. Cost of Retesting.
- a. Cost for Retesting shall be determined by and be the responsibility of the CM.
 4. The Contractor shall respond in writing to the CA and CM at least as often as commissioning meetings are being scheduled concerning the status of each apparent outstanding discrepancy identified during commissioning. Discussion shall cover explanations of any disagreements and proposals for their resolution.
 5. The CA retains the original non-conformance forms until the end of the project.
 6. Any required retesting by any contractor shall not be considered a justified reason for a claim of delay or for a time extension by the prime contractor.
- C. Failure Due to Manufacturer Defect: If 10%, or three, whichever is greater, of identical pieces (size alone does not constitute a difference) of equipment fail to perform to the Contract Documents (mechanically or substantively) due to manufacturing defect, not allowing it to meet its submitted performance spec, all identical units may be considered unacceptable by the CM or PM. In such case, the Contractor shall provide the Owner with the following:
1. Within one week of notification from the CM or PM, the Contractor or manufacturer's representative shall examine all other identical units making a record of the findings. The findings shall be provided to the CM or PM within two weeks of the original notice.
 2. Within two weeks of the original notification, the Contractor or manufacturer shall provide a signed and dated, written explanation of the problem, cause of failures, etc. and all proposed solutions which shall include full equipment submittals. The proposed solutions shall not significantly exceed the specification requirements of the original installation.
 3. The CM or PM will determine whether a replacement of all identical units or a repair is acceptable.
 4. Two examples of the proposed solution will be installed by the Contractor and the CM will be allowed to test the installations for up to one week, upon which the CM or PM will decide whether to accept the solution.
 5. Upon acceptance, the Contractor and/or manufacturer shall replace or repair all identical items, at their expense and extend the warranty accordingly, if the original equipment warranty had begun. The replacement/repair work shall proceed with reasonable speed beginning within one week from when parts can be obtained.
- D. Approval: The CA notes each satisfactorily demonstrated function on the test form. Formal approval of the functional test is made later after review by the CA, A/E, the CM, if necessary. The CA recommends acceptance of each test to the CM using a standard form. The CM gives final approval on each test using the same form, providing a signed copy to the CA and the Contractor.

3.8. OPERATION AND MAINTENANCE MANUALS

- A. Standard O&M Manuals:
 - 1. The specific content and format requirements for the standard O&M manuals are detailed in the appropriate sections of the Contract Documents.

3.9 TRAINING OF OWNER PERSONNEL

- A. The CM is responsible for training coordination and scheduling, and ultimately for ensuring that all training is completed.
 - 1. Each Sub and vendor responsible for training will submit a written training plan to the CA, through the CM, for review and prior to training. The plan will cover the following elements:
 - a. Equipment (included in training)
 - b. Intended audience
 - c. Location of Training
 - d. Objectives
 - e. Subjects covered and approximate time devoted to each.
 - f. Qualified instructor
 - g. Method/Type of instruction, i.e., classroom, video, walk through, operational demonstrations, written materials, etc

3.10 DEFERRED TESTING

- A. Unforeseen Deferred Tests: If any check or test cannot be completed due to the building structure, required occupancy condition or other deficiency, execution of checklists and functional testing may be delayed upon approval of the PM. These tests will be conducted in the same manner as the seasonal tests as soon as possible. Services of necessary parties will be negotiated.
- B. Seasonal Testing: During the warranty period, seasonal testing if required, shall be completed as part of this contract. The CA shall coordinate this activity through the CM. The appropriate Functional Performance Tests will be executed and documented. A supplemental report will be completed by the CA and forwarded to the CM and Owner.

3.11 WRITTEN WORK PRODUCTS

- A. The commissioning process generates a number of written work products described in various parts of the Specifications. The Commissioning Plan—Construction Phase, lists all the formal written work products, describes briefly their contents, who is responsible to create them, their due dates, who receives and approves them and the location of the specification to create them. In summary, the written products are:

<u>Product</u>	<u>Developed By</u>
1. Final commissioning plan	CA
2. Cx Meeting minutes	CA
3. Commissioning schedules	CM with CA
4. Equipment documentation submittals	Subs
5. Sequence clarifications	Subs and A/E as needed

- | | |
|---|------|
| 5. Prefunctional checklists | Subs |
| 6. Startup and initial checkout plan | Subs |
| 7. Startup and initial checkout
forms filled out | Subs |
| 8. Final TAB report | TAB |
| 9. Issues log (Action List) | CA |
| 10. Functional test forms | CA |
| 11. Completed functional tests | CA |
| 12. O&M manuals | Subs |
| 13. Overall training plan | Subs |
| 14. Specific training agendas | Subs |
| 15. Final commissioning report | CA |

END OF SECTION

THIS PAGE INTENTIONALLY LEFT BLANK

SECTION 02 41 16

BUILDING DEMOLITION

PART 1 - GENERAL

1.01 SECTION INCLUDES

- A. This Section includes the demolition and removal of existing buildings, utilities and other structures or debris as indicated in these documents.

1.02 RELATED WORK SPECIFIED ELSEWHERE

- A. Removals, Cutting and Patching: Section 01 70 0.
- B. Construction Facilities and Temporary Controls: Section 01 50 00.
- C. Earthwork: Section 31 00 00.

1.03 SUBMITTALS

- A. Quality Control Submittals:
 - 1. Permits: Submit one copy of each permit.
 - 2. Demolition Plan: For information only, submit one copy of the demolition plan required under Quality Assurance Article.
- B. Provide written proof from the Town, City and/or utility companies that all public and private services and utilities have been properly sealed off and that the Contractor has complied with all State and Local Health Laws before proceeding with the demolition.

1.04 QUALITY ASSURANCE

- A. Permits: Before the Work of this Section is started, obtain all permits required by Federal, State, and local jurisdictions for all phases and operations of the Work.
- B. Demolition Plan: Before the Work of this Section is started, prepare a detailed demolition plan. The demolition plan shall include, but not be limited to, detailed outline of intended demolition and disposal procedures. The demolition plan will not relieve the Contractor of complete responsibility for the successful performance of the Work in accordance with all applicable Federal, State, and local codes and restrictions.

1.05 PROJECT CONDITIONS

- A. Existing Paint: Assume existing painted surfaces to contain lead based paints. Take precautions as required to prevent spread of lead containing particles and dust.
- B. Recycle demolition debris to the greatest extent possible.
- C. Burning is prohibited.

- D. The use of explosives is prohibited.
- E. Verify the location and status of all utilities within the Contract Limit Line (CLL).
- F. Protect utilities during the Work of this Section.
- G. Disconnect the following utilities as required:
 - 1. Sewer: Plug or grout inside of nearest manhole. Remove abandoned lateral from the building to a point 5 feet from the building line.
 - 2. Water: Cut and plug at nearest main. Install thrust blocks at caps and plugs.
 - 3. Gas: Comply with utility regulations.
 - 4. Electric: Comply with National Electric Code and utility regulations.
 - 5. Telephone: Comply with utility regulations.
- H. Prior to beginning demolition, verify that all utilities serving the building to be demolished have been disconnected.
- I. Do not interrupt utility services to buildings which are to remain.

PART 2 - PRODUCTS

2.01 MATERIALS

- A. Plugs, Caps, Flanges: Approved cast iron thread plugs, welded caps, or flanges.
- B. Grout: ASTM C 476.
- C. Thrust Blocks: Minimum 2500 psi concrete.
- D. Selected Fill: As specified in Section 31 00 00.

PART 3 - EXECUTION

3.01 PREPARATION

- A. Provide temporary 6 foot high chain link fence, including all required gates, around the building prior to start of the Work of this Section. Locate temporary fence where directed. Remove temporary fence in its entirety, including all anchorage materials, after completion of backfill operations.
- B. Vermin Control: Employ a "Certified Commercial Applicator", certified by the State, to exterminate rodents and vermin in the building and tunnels to be demolished.
- C. Search each building. Locate drums or containers of hazardous wastes. Remove hazardous wastes in accordance with Federal and State regulations.
- D. Remove loose equipment, materials, supplies, and furnishings (desks, chairs, beds, mattresses, furniture, etc.) from building prior to demolition.

- E. Remove items scheduled to be salvaged and place in a designated storage area.
- F. Items of salvable value to the Contractor may be removed from the structure as the work progresses. Salvaged items must be transported from the site as they are removed. Storage or sale of removed items on the site will not be permitted.
- G. Pump out standing water from basement and crawl space areas of the building prior to demolition. Remove all mechanical equipment, piping, etc. from basement areas prior to demolition.
- H. Pump out cesspools, septic tanks, and fuel tanks and remove contents from site.
- I. Protect adjacent buildings, structures and vegetation scheduled to remain from damage.

3.02 DEMOLITION

- A. Perform demolition in a systematic manner, beginning at the top of the structure and proceeding to lowest basement floor. Complete demolition above each floor level before disturbing supporting members on lower levels.
- B. Wet down masonry and plaster materials during demolition to prevent spread of dust and dirt. Sprinkle debris, and use temporary enclosures as necessary to limit dust to lowest practicable level. Do not use water to extent causing flooding, contaminated runoff, or icing.
- C. Do not place demolition equipment in buildings where it will create excessive loads on supporting walls, floors, and frames. Promptly remove accumulated debris and materials.
- D. Lower structural framing members to ground by hoist or crane.
- E. Remove floors over basement construction and remove on-grade slabs.
- F. Break lowest basement slabs to less than 3 feet in any dimension.
- G. Remove interior walls level to lowest basement slab.
- H. Remove below grade combustible material, glass and metal.
- I. Remove walks, roads, pavements, curbs, slabs on grade, and fences within CLL, unless shown or directed otherwise.

3.03 DISPOSAL

- A. Remove demolition debris from property as soon as practicable.
- B. Do not store, sell, or burn materials on property.

3.04 BACKFILLING AND GRADING

- A. Place fill in basements and other voids within the project limit line. Where broken concrete and masonry materials are used for backfill, place fill in layers not exceeding 12 inches and compact

each layer. Broken concrete and masonry shall not be used as fill material outside the limits defined by the original building foundation walls.

B. Final 12 inches of backfill below topsoil elevations shall be selected fill.

C. Rough grade surface to adjacent contours and slope to drain.

3.05 SALVAGE SCHEDULE

A. The existing Greenhouse is to be carefully dismantled by the Contractor and stored on Roger Williams Zoo property in location as directed by the Owner.

END OF SECTION

SECTION 03 30 00

CAST-IN-PLACE CONCRETE

PART 1 - GENERAL

1.1 RELATED DOCUMENTS

- A. Drawings and general provisions of the Contract, including General and Supplementary Conditions and Division 1 Specification Sections, apply to this Section.

1.2 SUMMARY

- A. This Section specifies cast-in place concrete, including formwork, reinforcement, concrete materials, mixture design, placement procedures, and finishes, for the following:
 - 1. Footings.
 - 2. Foundation walls.
 - 3. Slabs-on-grade.
 - 4. Slabs-on-deck.
- B. Related Sections include the following:
 - 1. Division 31 Section "Earthwork" for drainage fill under slabs-on-grade.
 - 2. Division 03 Section "Cement Concrete Sidewalk" for concrete pavement and walks.

1.3 DEFINITIONS

- A. Cementitious Materials: Portland cement alone or in combination with one or more of the following: blended hydraulic cement, fly ash and other pozzolans, ground granulated blast-furnace slag, and silica fume; subject to compliance with requirements.

1.4 SUBMITTALS

- A. Product Data: For each type of product indicated.
- B. Design Mixtures: For each concrete mixture. Submit alternate design mixtures when characteristics of materials, Project conditions, weather, test results, or other circumstances warrant adjustments.
 - 1. Indicate amounts of mixing water to be withheld for later addition at Project site.
- C. Steel Reinforcement Shop Drawings: Placing drawings that detail fabrication, bending, and placement. Include bar sizes, lengths, material, grade, bar schedules, stirrup spacing, bent bar diagrams, bar

arrangement, splices and laps, mechanical connections, tie spacing, hoop spacing, and supports for concrete reinforcement.

- D. Qualification Data: For Installer and manufacturer.
- E. Material Test Reports: For the following, from a qualified testing agency, indicating compliance with requirements:
 - 1. Aggregates. Include service record data indicating absence of deleterious expansion of concrete due to alkali aggregate reactivity.
- F. Material Certificates: For each of the following, signed by manufacturers:
 - 1. Cementitious materials.
 - 2. Admixtures.
 - 3. Steel reinforcement and accessories.
 - 4. Curing compounds.
 - 5. Floor and slab treatments.
 - 6. Bonding agents.
 - 7. Adhesives.
 - 8. Vapor retarders.
 - 9. Semi rigid joint filler.
 - 10. Joint-filler strips.
 - 11. Repair materials.
- G. Field quality-control test and inspection reports.

1.5 QUALITY ASSURANCE

- A. Manufacturer Qualifications: A firm experienced in manufacturing ready-mixed concrete products and that complies with ASTM C 94/C 94M requirements for production facilities and equipment.
 - 1. Manufacturer certified according to NRMCA's "Certification of Ready Mixed Concrete Production Facilities."
- B. Testing Agency Qualifications: An independent agency, acceptable to authorities having jurisdiction, qualified according to ASTM C 1077 and ASTM E 329 for testing indicated, as documented according to ASTM E 548.
 - 1. Personnel conducting field tests shall be qualified as ACI Concrete Field Testing Technician, Grade 1, according to ACI CP-01 or an equivalent certification program.
 - 2. Personnel performing laboratory tests shall be ACI-certified Concrete Strength Testing Technician and Concrete Laboratory Testing Technician - Grade I. Testing Agency laboratory supervisor shall be an ACI-certified Concrete Laboratory Testing Technician - Grade II.
- C. Source Limitations: Obtain each type or class of cementitious material of the same brand from the same manufacturer's plant, obtain aggregate from one source, and obtain admixtures through one source from a single manufacturer.

- D. ACI Publications: Comply with the following unless modified by requirements in the Contract Documents:
 - 1. ACI 301, "Specification for Structural Concrete."
 - 2. ACI 117, "Specifications for Tolerances for Concrete Construction and Materials."
- E. Concrete Testing Service: Engage a qualified independent testing agency to perform material evaluation tests and to design concrete mixtures.

1.6 DELIVERY, STORAGE, AND HANDLING

- A. Steel Reinforcement: Deliver, store, and handle steel reinforcement to prevent bending and damage.
- B. Waterstops: Store waterstops under cover to protect from moisture, sunlight, dirt, oil, and other contaminants.

PART 2 - PRODUCTS

2.1 MANUFACTURERS

- A. In other Part 2 articles where titles below introduce lists, the following requirements apply to product selection:
 - 1. Available Products: Subject to compliance with requirements, products that may be incorporated into the Work include, but are not limited to, products specified.
 - 2. Available Manufacturers: Subject to compliance with requirements, manufacturers offering products that may be incorporated into the Work include, but are not limited to, manufacturers specified.

2.2 FORM-FACING MATERIALS

- A. Rough-Formed Finished Concrete: Plywood, lumber, metal, or another approved material. Provide lumber dressed on at least two edges and one side for tight fit.
- B. Form-Release Agent: Commercially formulated form-release agent that will not bond with, stain, or adversely affect concrete surfaces and will not impair subsequent treatments of concrete surfaces.
 - 1. Formulate form-release agent with rust inhibitor for steel form-facing materials.
- C. Form Ties: Factory-fabricated, removable or snap-off metal or glass-fiber-reinforced plastic form ties designed to resist lateral pressure of fresh concrete on forms and to prevent spalling of concrete on removal.
 - 1. Furnish units that will leave no corrodible metal closer than 1 inch (25 mm) to the plane of exposed concrete surface.
 - 2. Furnish ties that, when removed, will leave holes no larger than 1 inch (25 mm) in diameter in concrete surface.

2.3 STEEL REINFORCEMENT

- A. Reinforcing Bars: ASTM A 615/A 615M, Grade 60.
- B. Galvanized Reinforcing Bar: ASTM A 767 for dowels and bars in slab-on-grade
- C. Plain-Steel Wire: ASTM A 82.
- D. Plain-Steel Welded Wire Reinforcement: ASTM A 1064, plain, fabricated from as-drawn steel wire into flat sheets.
- E. Galvanized Welded Wire Reinforcement: ASMT A 1060 for wire in slab-on-grade

2.4 REINFORCEMENT ACCESSORIES

- A. Bar Supports: Bolsters, chairs, spacers, and other devices for spacing, supporting, and fastening reinforcing bars and welded wire reinforcement in place. Manufacture bar supports from steel wire, plastic, or precast concrete according to CRSI's "Manual of Standard Practice," of greater compressive strength than concrete and as follows:
 - 1. For concrete surfaces exposed to view where legs of wire bar support contact forms, use CRSI Class 1 plastic-protected steel wire or CRSI Class 2 stainless-steel bar supports.

2.5 CONCRETE MATERIALS

- A. Cementitious Material: Use the following cementitious materials, of the same type, brand, and source, throughout Project:
 - 1. Portland Cement: ASTM C 150, Type I/II.
- B. Normal-Weight Aggregates: ASTM C 33. Provide aggregates from a single source.
 - 1. Maximum Coarse-Aggregate Size: 3/4 inch (19 mm) nominal.
 - 2. Fine Aggregate: Free of materials with deleterious reactivity to alkali in cement.
- C. Water: ASTM C 94/C 94M and potable.

2.6 ADMIXTURES

- A. Air-Entraining Admixture: ASTM C 260.
- B. Chemical Admixtures: Provide admixtures certified by manufacturer to be compatible with other admixtures and that will not contribute water-soluble chloride ions exceeding those permitted in hardened concrete. Do not use calcium chloride or admixtures containing calcium chloride.
 - 1. Water-Reducing Admixture: ASTM C 494/C 494M, Type A.
 - 2. Retarding Admixture: ASTM C 494/C 494M, Type B.

3. Water-Reducing and Retarding Admixture: ASTM C 494/C 494M, Type D.
4. High-Range, Water-Reducing Admixture: ASTM C 494/C 494M.
5. Plasticizing and Retarding Admixture: ASTM C 1017/C 1017M, Type II.

- C. Plastic Vapor Retarder: ASTM E 1745, Class C or polyethylene sheet, ASTM D 4397, not less than 10 mils. Include manufacturer's recommended adhesive or pressure-sensitive joint tape.
- a. Fortifiber Corporation; Moistop Plus.
 - b. Raven Industries Inc.; Dura Skrim 6.
 - c. Reef Industries, Inc.; Griffolyn Type-65.
 - d. Stego Industries, LLC; Stego Wrap, 10 mils.
- D. Granular Fill: Clean mixture of crushed stone or crushed or uncrushed gravel; ASTM D 448, Size 57, with 100 percent passing a 1-1/2-inch (37.5-mm) sieve and 0 to 5 percent passing a No. 8 (2.36-mm) sieve.

2.7 CURING MATERIALS

- A. Clear, Waterborne, Membrane-Forming Curing and Sealing Compound: ASTM C 1315, Type 1, Class A.
1. Available Products:
 - a. Burke by Edoco; Cureseal 1315 WB.
 - b. ChemMasters; Polyseal WB.
 - c. Conspec Marketing & Manufacturing Co., Inc., a Dayton Superior Company; Sealcure 1315 WB.
 - d. Euclid Chemical Company (The); Super Diamond Clear VOX.
 - e. Kaufman Products, Inc.; Sure Cure 25 Emulsion.
 - f. Lambert Corporation; UV Safe Seal.
 - g. L&M Construction Chemicals, Inc.; Lumiseal WB Plus.
 - h. Meadows, W. R., Inc.; Vocomp-30.
 - i. Metalcrete Industries; Metcure 30.
 - j. Symons Corporation, a Dayton Superior Company; Cure & Seal 31 Percent E.
 - k. Tamms Industries, Inc.; LusterSeal WB 300.
 - l. Unitex; Hydro Seal 25.
 - m. US Mix Products Company; US Spec Radiance UV-25.
 - n. Vexcon Chemicals, Inc.; Vexcon Starseal 1315.

2.8 RELATED MATERIALS

- A. Expansion- and Isolation-Joint-Filler Strips: ASTM D 1751, asphalt-saturated cellulosic fiber.
- B. Epoxy Bonding Adhesive: ASTM C 881, two-component epoxy resin, capable of humid curing and bonding to damp surfaces, of class suitable for application temperature and of grade to suit requirements, and as follows:
1. Types IV and V, load bearing, for bonding hardened or freshly mixed concrete to hardened concrete.

2.9 REPAIR MATERIALS

- A. Repair Underlayment: Cement-based, polymer-modified, self-leveling product that can be applied in thicknesses from 1/8 inch (3.2 mm) and that can be feathered at edges to match adjacent floor elevations.
 - 1. Cement Binder: ASTM C 150, portland cement or hydraulic or blended hydraulic cement as defined in ASTM C 219.
 - 2. Primer: Product of underlayment manufacturer recommended for substrate, conditions, and application.
 - 3. Aggregate: Well-graded, washed gravel, 1/8 to 1/4 inch (3.2 to 6 mm) or coarse sand as recommended by underlayment manufacturer.
 - 4. Compressive Strength: Not less than 4100 psi (29 MPa) at 28 days when tested according to ASTM C 109/C 109M.

- B. Repair Overlayment: Cement-based, polymer-modified, self-leveling product that can be applied in thicknesses from 1/8 inch (3.2 mm) and that can be feathered at edges to match adjacent floor elevations.
 - 1. Cement Binder: ASTM C 150, portland cement or hydraulic or blended hydraulic cement as defined in ASTM C 219.
 - 2. Primer: Product of topping manufacturer recommended for substrate, conditions, and application.
 - 3. Aggregate: Well-graded, washed gravel, 1/8 to 1/4 inch (3.2 to 6 mm) or coarse sand as recommended by topping manufacturer.
 - 4. Compressive Strength: Not less than 5000 psi (34.5 MPa) at 28 days when tested according to ASTM C 109/C 109M.

2.10 CONCRETE MIXTURES, GENERAL

- A. Prepare design mixtures for each type and strength of concrete, proportioned on the basis of laboratory trial mixture or field test data, or both, according to ACI 301.
 - 1. Use a qualified independent testing agency for preparing and reporting proposed mixture designs based on laboratory trial mixtures.

- B. Limit water-soluble, chloride-ion content in hardened concrete to 0.06 percent by weight of cement.

- C. Admixtures: Use admixtures according to manufacturer's written instructions.
 - 1. Use water-reducing admixture in all concrete, as required, for placement and workability.
 - 2. Use water-reducing and retarding admixture when required by high temperatures, low humidity, or other adverse placement conditions.

2.11 CONCRETE MIXTURES FOR BUILDING ELEMENTS

- A. Exterior Concrete
 - 1. Minimum Compressive Strength: 5,000 psi (27.6 MPa) at 28 days.

2. Maximum Water-Cementitious Materials Ratio: 0.45.
3. Slump Limit: 4 inches (100 mm), plus or minus 1 inch (25 mm).
4. Air Content: 5-1/2 percent, plus or minus 1.5 percent at point of delivery for 1-1/2-inch (38-mm) nominal maximum aggregate size.

B. Interior Concrete

1. Minimum Compressive Strength: 4,000 psi (27.6 MPa) at 28 days.
2. Minimum Cementitious Materials Content: 564 lb/cu. yd. (335 kg/cu. m).
3. Slump Limit: 5 inches (125 mm), plus or minus 1 inch (25 mm).
4. Air Content: Do not allow air content of troweled finished floors to exceed 3 percent.

2.12 FABRICATING REINFORCEMENT

- A. Fabricate steel reinforcement according to CRSI's "Manual of Standard Practice."

2.13 CONCRETE MIXING

- A. Ready-Mixed Concrete: Measure, batch, mix, and deliver concrete according to ASTM C 94/C 94M, and furnish batch ticket information.

1. When air temperature is between 85 and 90 deg F (30 and 32 deg C), reduce mixing and delivery time from 1-1/2 hours to 75 minutes; when air temperature is above 90 deg F (32 deg C), reduce mixing and delivery time to 60 minutes.

- B. Project-Site Mixing: Measure, batch, and mix concrete materials and concrete according to ASTM C 94/C 94M. Mix concrete materials in appropriate drum-type batch machine mixer.

1. For mixer capacity of 1 cu. yd. (0.76 cu. m) or smaller, continue mixing at least 1-1/2 minutes, but not more than 5 minutes after ingredients are in mixer, before any part of batch is released.
2. For mixer capacity larger than 1 cu. yd. (0.76 cu. m), increase mixing time by 15 seconds for each additional 1 cu. yd. (0.76 cu. m).
3. Provide batch ticket for each batch discharged and used in the Work, indicating Project identification name and number, date, mixture type, mixture time, quantity, and amount of water added. Record approximate location of final deposit in structure.

PART 3 - EXECUTION

3.1 FORMWORK

- A. Design, erect, brace, and maintain formwork, according to ACI 301, to support lateral, static, and dynamic loads, and construction loads that might be applied, until structure can support such loads.
- B. Construct formwork so concrete members and structures are of size, shape, alignment, elevation, and position indicated, within tolerance limits of ACI 117.

- C. Limit concrete surface irregularities, designated by ACI 347R as abrupt or gradual, as follows:
 - 1. Class A, 1/8 inch (3.2 mm) for smooth-formed finished surfaces.
 - 2. Class B, 1/4 inch (6 mm) for rough-formed finished surfaces.
- D. Construct forms tight enough to prevent loss of concrete mortar.
- E. Fabricate forms for easy removal without hammering or prying against concrete surfaces. Provide crush or wrecking plates where stripping may damage cast concrete surfaces. Provide top forms for inclined surfaces steeper than 1.5 horizontal to 1 vertical.
 - 1. Install keyways, reglets, recesses, and the like, for easy removal.
 - 2. Do not use rust-stained steel form-facing material.
- F. Provide temporary openings for cleanouts and inspection ports where interior area of formwork is inaccessible. Close openings with panels tightly fitted to forms and securely braced to prevent loss of concrete mortar. Locate temporary openings in forms at inconspicuous locations.
- G. Clean forms and adjacent surfaces to receive concrete. Remove chips, wood, sawdust, dirt, and other debris just before placing concrete.
- H. Retighten forms and bracing before placing concrete, as required, to prevent mortar leaks and maintain proper alignment.
- I. Coat contact surfaces of forms with form-release agent, according to manufacturer's written instructions, before placing reinforcement.

3.2 EMBEDDED ITEMS

- A. Place and secure anchorage devices and other embedded items required for adjoining work that is attached to or supported by cast-in-place concrete. Use setting drawings, templates, diagrams, instructions, and directions furnished with items to be embedded.
 - 1. Install anchor rods, accurately located, to elevations required and complying with tolerances in Section 7.5 of AISC's "Code of Standard Practice for Steel Buildings and Bridges."

3.3 VAPOR RETARDERS

- A. Plastic Vapor Retarders: Place, protect, and repair vapor retarders according to ASTM E 1643 and manufacturer's written instructions.
 - 1. Lap joints 6 inches (150 mm) and seal with manufacturer's recommended tape.
- B. Granular Course: Compact granular fill with mechanical equipment to elevation tolerances of plus 0 inch (0 mm) or minus 3/4 inch (19 mm).

3.4 STEEL REINFORCEMENT

- A. General: Comply with CRSI's "Manual of Standard Practice" for placing reinforcement.
 - 1. Do not cut or puncture vapor retarder. Repair damage and reseal vapor retarder before placing concrete.
- B. Clean reinforcement of loose rust and mill scale, earth, ice, and other foreign materials that would reduce bond to concrete.
- C. Accurately position, support, and secure reinforcement against displacement. Locate and support reinforcement with bar supports to maintain minimum concrete cover. Do not tack weld crossing reinforcing bars.

3.5 CONCRETE PLACEMENT

- A. Before placing concrete, verify that installation of formwork, reinforcement, and embedded items is complete and that required inspections have been performed.
- B. Do not add water to concrete during delivery, at Project site, or during placement unless approved by Architect.
- C. Before test sampling and placing concrete, water may be added at Project site, subject to limitations of ACI 301.
 - 1. Do not add water to concrete after adding high-range water-reducing admixtures to mixture.
- D. Deposit concrete continuously in one layer or in horizontal layers of such thickness that no new concrete will be placed on concrete that has hardened enough to cause seams or planes of weakness. If a section cannot be placed continuously, provide construction joints as indicated. Deposit concrete to avoid segregation.
 - 1. Deposit concrete in horizontal layers of depth to not exceed formwork design pressures and in a manner to avoid inclined construction joints.
 - 2. Consolidate placed concrete with mechanical vibrating equipment according to ACI 301.
 - 3. Do not use vibrators to transport concrete inside forms. Insert and withdraw vibrators vertically at uniformly spaced locations to rapidly penetrate placed layer and at least 6 inches (150 mm) into preceding layer. Do not insert vibrators into lower layers of concrete that have begun to lose plasticity. At each insertion, limit duration of vibration to time necessary to consolidate concrete and complete embedment of reinforcement and other embedded items without causing mixture constituents to segregate.
- E. Cold-Weather Placement: Comply with ACI 306.1 and as follows. Protect concrete work from physical damage or reduced strength that could be caused by frost, freezing actions, or low temperatures.

1. When average high and low temperature is expected to fall below 40 deg F (4.4 deg C) for three successive days, maintain delivered concrete mixture temperature within the temperature range required by ACI 301.
2. Do not use frozen materials or materials containing ice or snow. Do not place concrete on frozen subgrade or on subgrade containing frozen materials.
3. Do not use calcium chloride, salt, or other materials containing antifreeze agents or chemical accelerators unless otherwise specified and approved in mixture designs.

F. Hot-Weather Placement: Comply with ACI 301 and as follows:

1. Maintain concrete temperature below 90 deg F (32 deg C) at time of placement. Chilled mixing water or chopped ice may be used to control temperature, provided water equivalent of ice is calculated to total amount of mixing water. Using liquid nitrogen to cool concrete is Contractor's option.
2. Fog-spray forms, steel reinforcement, and subgrade just before placing concrete. Keep subgrade uniformly moist without standing water, soft spots, or dry areas.

3.6 FINISHING FORMED SURFACES

- A. Rough-Formed Finish: As-cast concrete texture imparted by form-facing material with tie holes and defects repaired and patched. Remove fins and other projections that exceed specified limits on formed-surface irregularities.
1. Apply to concrete surfaces not exposed to public view.
- B. Related Unformed Surfaces: At tops of walls, horizontal offsets, and similar unformed surfaces adjacent to formed surfaces, strike off smooth and finish with a texture matching adjacent formed surfaces. Continue final surface treatment of formed surfaces uniformly across adjacent unformed surfaces, unless otherwise indicated.

3.7 FINISHING FLOORS AND SLABS

- A. General: Comply with ACI 302.1R recommendations for screeding, re-straightening, and finishing operations for concrete surfaces. Do not wet concrete surfaces.
- B. Float Finish: Consolidate surface with power-driven floats or by hand floating if area is small or inaccessible to power driven floats. Re-straighten, cut down high spots, and fill low spots. Repeat float passes and re-straightening until surface is left with a uniform, smooth, granular texture.
1. Apply float finish to surfaces to receive trowel finish and to be covered with fluid-applied or sheet waterproofing.
- C. Trowel Finish: After applying float finish, apply first troweling and consolidate concrete by hand or power-driven trowel. Continue troweling passes and re-straighten until surface is free of trowel marks and uniform in texture and appearance. Grind smooth any surface defects that would telegraph through applied coatings or floor coverings.

1. Apply a trowel finish to surfaces exposed to view or to be covered with resilient flooring, carpet, ceramic or quarry tile, or another thin-film-finish coating system.
 2. Finish surfaces to the following tolerances, according to ASTM E 1155 (ASTM E 1155M), for a randomly trafficked floor surface:
 - a. Specified overall values of flatness, F(F) 30; and of levelness, F(L) 20; with minimum local values of flatness, F(F) 24; and of levelness, F(L) 15; for suspended slabs.
 3. Finish and measure surface so gap at any point between concrete surface and an unlevelled, freestanding, 10-foot- (3.05-m-) long straightedge resting on 2 high spots and placed anywhere on the surface does not exceed 3/16 inch (4.8 mm).
- D. Broom Finish: Apply a broom finish to exterior concrete platforms, steps, and ramps, and elsewhere as indicated.
1. Immediately after float finishing, slightly roughen trafficked surface by brooming with fiber-bristle broom perpendicular to main traffic route. Coordinate required final finish with Architect before application.

3.8 MISCELLANEOUS CONCRETE ITEMS

- A. Filling In: Fill in holes and openings left in concrete structures, unless otherwise indicated, after work of other trades is in place. Mix, place, and cure concrete, as specified, to blend with in-place construction. Provide other miscellaneous concrete filling indicated or required to complete the Work.
- B. Equipment Bases and Foundations: Provide machine and equipment bases and foundations as shown on Drawings. Set anchor bolts for machines and equipment at correct elevations, complying with diagrams or templates from manufacturer furnishing machines and equipment.

3.9 CONCRETE PROTECTING AND CURING

- A. General: Protect freshly placed concrete from premature drying and excessive cold or hot temperatures. Comply with ACI 306.1 for cold-weather protection and ACI 301 for hot-weather protection during curing.
- B. Evaporation Retarder: Apply evaporation retarder to unformed concrete surfaces if hot, dry, or windy conditions cause moisture loss approaching 0.2 lb/sq. ft. x h (1 kg/sq. m x h) before and during finishing operations. Apply according to manufacturer's written instructions after placing, screeding, and bull floating or darbying concrete, but before float finishing.
- C. Formed Surfaces: Cure formed concrete surfaces, including underside of beams, supported slabs, and other similar surfaces. If forms remain during curing period, moist cure after loosening forms. If removing forms before end of curing period, continue curing for the remainder of the curing period.
- D. Unformed Surfaces: Begin curing immediately after finishing concrete. Cure unformed surfaces, including floors and slabs, concrete floor toppings, and other surfaces.

- E. Cure concrete according to ACI 308.1, by one or a combination of the following methods:
1. Moisture Curing: Keep surfaces continuously moist for not less than seven days with the following materials:
 - a. Water.
 - b. Continuous water-fog spray.
 - c. Absorptive cover, water saturated, and kept continuously wet. Cover concrete surfaces and edges with 12-inch (300-mm) lap over adjacent absorptive covers.
 2. Moisture-Retaining-Cover Curing: Cover concrete surfaces with moisture-retaining cover for curing concrete, placed in widest practicable width, with sides and ends lapped at least 12 inches (300 mm), and sealed by waterproof tape or adhesive. Cure for not less than seven days. Immediately repair any holes or tears during curing period using cover material and waterproof tape.
 - a. Moisture cure or use moisture-retaining covers to cure concrete surfaces to receive floor coverings.
 - b. Moisture cure or use moisture-retaining covers to cure concrete surfaces to receive penetrating liquid floor treatments.
 - c. Cure concrete surfaces to receive floor coverings with either a moisture-retaining cover or a curing compound that the manufacturer certifies will not interfere with bonding of floor covering used on Project..
 3. Curing and Sealing Compound: Apply uniformly to floors and slabs indicated in a continuous operation by power spray or roller according to manufacturer's written instructions. Recoat areas subjected to heavy rainfall within three hours after initial application. Repeat process 24 hours later and apply a second coat. Maintain continuity of coating and repair damage during curing period.

3.10 JOINT FILLING

- A. Prepare, clean, and install joint filler according to manufacturer's written instructions.
 1. Do not fill joints until construction traffic has permanently ceased.
- B. Remove dirt, debris, saw cuttings, curing compounds, and sealers from joints; leave contact faces of joint clean and dry.
- C. Install semi rigid joint filler full depth in saw-cut joints and at least 2 inches (50 mm) deep in formed joints. Overfill joint and trim joint filler flush with top of joint after hardening.

3.11 CONCRETE SURFACE REPAIRS

- A. Defective Concrete: Repair and patch defective areas when approved by Architect. Remove and replace concrete that cannot be repaired and patched to Architect's approval.

- B. Patching Mortar: Mix dry-pack patching mortar, consisting of one part portland cement to two and one-half parts fine aggregate passing a No. 16 (1.18-mm) sieve, using only enough water for handling and placing.
- C. Repairing Formed Surfaces: Surface defects include color and texture irregularities, cracks, spalls, air bubbles, honeycombs, rock pockets, fins and other projections on the surface, and stains and other discolorations that cannot be removed by cleaning.
1. Immediately after form removal, cut out honeycombs, rock pockets, and voids more than 1/2 inch (13 mm) in any dimension in solid concrete, but not less than 1 inch (25 mm) in depth. Make edges of cuts perpendicular to concrete surface. Clean, dampen with water, and brush-coat holes and voids with bonding agent. Fill and compact with patching mortar before bonding agent has dried. Fill form-tie voids with patching mortar or cone plugs secured in place with bonding agent.
 2. Repair defects on surfaces exposed to view by blending white portland cement and standard portland cement so that, when dry, patching mortar will match surrounding color. Patch a test area at inconspicuous locations to verify mixture and color match before proceeding with patching. Compact mortar in place and strike off slightly higher than surrounding surface.
 3. Repair defects on concealed formed surfaces that affect concrete's durability and structural performance as determined by Architect.
- D. Repairing Unformed Surfaces: Test unformed surfaces, such as floors and slabs, for finish and verify surface tolerances specified for each surface. Correct low and high areas. Test surfaces sloped to drain for trueness of slope and smoothness; use a sloped template.
1. Repair finished surfaces containing defects. Surface defects include spalls, popouts, honeycombs, rock pockets, crazing and cracks in excess of 0.01 inch (0.25 mm) wide or that penetrate to reinforcement or completely through unreinforced sections regardless of width, and other objectionable conditions.
 2. After concrete has cured at least 14 days, correct high areas by grinding.
 3. Correct localized low areas during or immediately after completing surface finishing operations by cutting out low areas and replacing with patching mortar. Finish repaired areas to blend into adjacent concrete.
 4. Correct other low areas scheduled to receive floor coverings with a repair underlayment. Prepare, mix, and apply repair underlayment and primer according to manufacturer's written instructions to produce a smooth, uniform, plane, and level surface. Feather edges to match adjacent floor elevations.
 5. Correct other low areas scheduled to remain exposed with a repair topping. Cut out low areas to ensure a minimum repair topping depth of 1/4 inch (6 mm) to match adjacent floor elevations. Prepare, mix, and apply repair topping and primer according to manufacturer's written instructions to produce a smooth, uniform, plane, and level surface.
 6. Repair defective areas, except random cracks and single holes 1 inch (25 mm) or less in diameter, by cutting out and replacing with fresh concrete. Remove defective areas with clean, square cuts and expose steel reinforcement with at least a 3/4-inch (19-mm) clearance all around. Dampen concrete surfaces in contact with patching concrete and apply bonding agent. Mix patching concrete of same materials and mixture as original concrete except without coarse aggregate. Place, compact, and finish to blend with adjacent finished concrete. Cure in same manner as adjacent concrete.
 7. Repair random cracks and single holes 1 inch (25 mm) or less in diameter with patching mortar. Groove top of cracks and cut out holes to sound concrete and clean off dust, dirt, and loose particles. Dampen cleaned concrete surfaces and apply bonding agent. Place patching mortar before bonding

agent has dried. Compact patching mortar and finish to match adjacent concrete. Keep patched area continuously moist for at least 72 hours.

- E. Perform structural repairs of concrete, subject to Architect's approval, using epoxy adhesive and patching mortar.
- F. Repair materials and installation not specified above may be used, subject to Architect's approval.

3.12 FIELD QUALITY CONTROL

- A. Testing and Inspecting: Engage a qualified testing and inspecting agency to perform tests and inspections and to submit reports.

- B. Inspections:

- 1. Steel reinforcement placement.
- 2. Steel reinforcement welding.
- 3. Headed bolts and studs.
- 4. Verification of use of required design mixture.
- 5. Concrete placement, including conveying and depositing.
- 6. Curing procedures and maintenance of curing temperature.
- 7. Verification of concrete strength before removal of shores and forms from beams and slabs.

- C. Concrete Tests: Testing of composite samples of fresh concrete obtained according to ASTM C 172 shall be performed according to the following requirements:

- 1. Testing Frequency: Obtain one composite sample for each day's pour of each concrete mixture exceeding 5 cu. yd. (4 cu. m), but less than 25 cu. yd. (19 cu. m), plus one set for each additional 50 cu. yd. (38 cu. m) or fraction thereof.
- 2. Slump: ASTM C 143/C 143M; one test at point of placement for each composite sample, but not less than one test for each day's pour of each concrete mixture. Perform additional tests when concrete consistency appears to change.
- 3. Air Content: ASTM C 231, pressure method, for normal-weight concrete; one test for each composite sample, but not less than one test for each day's pour of each concrete mixture.
- 4. Concrete Temperature: ASTM C 1064/C 1064M; one test hourly when air temperature is 40 deg F (4.4 deg C) and below and when 80 deg F (27 deg C) and above, and one test for each composite sample.
- 5. Unit Weight: ASTM C 567, fresh unit weight of structural lightweight concrete; one test for each composite sample, but not less than one test for each day's pour of each concrete mixture.
- 6. Compression Test Specimens: ASTM C 31/C 31M.
 - a. Cast and laboratory cure five standard cylinder specimens for each composite sample.
- 7. Compressive-Strength Tests: ASTM C 39/C 39M; test one laboratory-cured specimen at 7 days, one specimen at 14 days, and three specimens at 28 days.
 - a. A compressive-strength test shall be the average compressive strength from a set of two specimens obtained from same composite sample and tested at age indicated.

8. When strength of field-cured cylinders is less than 85 percent of companion laboratory-cured cylinders, Contractor shall evaluate operations and provide corrective procedures for protecting and curing in-place concrete.
9. Strength of each concrete mixture will be satisfactory if every average of any three consecutive compressive-strength tests equals or exceeds specified compressive strength and no compressive-strength test value falls below specified compressive strength by more than 500 psi (3.4 MPa).
10. Test results shall be reported in writing to Architect, Structural Engineer, concrete manufacturer, and Contractor within 48 hours of testing. Reports of compressive-strength tests shall contain Project identification name and number, date of concrete placement, name of concrete testing and inspecting agency, location of concrete batch in Work, design compressive strength at 28 days, concrete mixture proportions and materials, compressive breaking strength, and type of break for all 7-, 14-, and 28-day tests.

END OF SECTION 03 30 00

THIS PAGE INTENTIONALLY LEFT BLANK

SECTION 03 30 55

CAST-IN-PLACE CONCRETE (SITE)

PART 1 - GENERAL

1.1 DESCRIPTION

- A. This Section specifies requirements for concrete cast-in-place on the site.
- B. The work includes cast-in-place concrete pavement, walkways, bases, utility foundations, site structures, and thrust blocks.

1.2 RELATED SECTIONS

- A. Sections which directly relate to the work of this Section include:
 - 1. Section 31 00 00 — EARTHWORK
 - 2. Section 32 16 10 — CURBING

1.3 REFERENCE STANDARDS

- A. References herein are made in accordance with the following abbreviations and all work under this Section shall conform to the latest editions as applicable.

- 1. American Concrete Institute (ACI):
 - 301 Specifications for Structural Concrete
 - 305R Hot Weather Concreting
 - 306R Cold Weather Concreting
 - 325.9R Guide for Construction of Concrete Pavements and Concrete Bases
- 2. ASTM International (ASTM):
 - A82 Standard Specification for Steel Wire, Plain, for Concrete Reinforcement
 - A1064 Standard Specification for Steel Wire and Welded Wire Reinforcement, Plain and Deformed, for Concrete
 - A615 Standard Specification for Deformed and Plain Carbon-Steel Bars for Concrete Reinforcement
 - C31 Standard Practice for Making and Curing Concrete Test Specimens in the Field
 - C33 Standard Specification for Concrete Aggregates
 - C94 Standard Specification for Ready-Mixed Concrete
 - C143 Standard Test Method for Slump of Hydraulic-Cement Concrete
 - C150 Standard Specification for Portland Cement
 - C171 Standard Specification for Sheet Materials for Curing Concrete

- C231 Standard Test Method for Air Content of Freshly Mixed Concrete by the Pressure Method
- C260 Standard Specification for Air-Entraining Admixtures for Concrete
- C309 Standard Specification for Liquid Membrane-Forming Compounds for Curing Concrete
- C494 Standard Specification for Chemical Admixtures for Concrete
- C1116 Standard Specification for Fiber-Reinforced Concrete

- 3. Concrete Reinforcing Steel Institute (CRSI): Manual of Standard Practice.
- 4. United States Department of Justice - Americans with Disabilities Act (ADA): ADA Accessibility Guidelines for Buildings and Facilities; 28 CFR Part 36.
- 5. State Regulations regarding Accessibility.

1.4 QUALITY ASSURANCE

- A. Work and materials for construction of the cement concrete walks shall conform to ACI 316R. Other cast-in-place concrete shall conform to ACI 301.
- B. Work, materials, and color of the wheelchair ramp paving shall conform to applicable sections of Americans with Disabilities Act (ADA) and State Standards, whichever is more stringent.
- C. Dimensions, locations, and details of equipment pads, anchors, supports, and similar features shown on the Drawings are approximate. Manufacturer's approved shop Drawings of equipment to be supported, anchored, or contained thereby shall be consulted for exact location, size, and details.

1.5 SUBMITTALS

- A. Submit description of methods and sequence of placement for each type of specially finished concrete, including description of methods and sequence of placement.
- B. Submit manufacturer's product data for the following:
 - 1. Form release agent.
 - 2. Preformed joint filler.
 - 3. Concrete reinforcement specification data from manufacturer.
 - 4. Manufacturer's literature for protective coating for sidewalks.
 - 5. Detectable Warning including manufacturer's certification that product complies with ADA.

1.6 TESTING

- A. The Owner may employ an independent testing laboratory to inspect and test concrete paving and other cast-in-place concrete work.
- B. When requested, Contractor shall prepare test specimens in accordance with ASTM C31, standard cylinder size 4-inch x 8 inch.

- C. Testing of materials and installed work may occur at any time during progress of the work. Rejected materials and installed work shall be removed and replaced.

PART 2 - PRODUCTS

2.1 STEEL REINFORCEMENT

- A. Steel reinforcing bars shall conform to ASTM A615, Grade 60, deformed.
 - 1. Bars employed as dowels shall be hot-rolled plain rounds.
- B. Steel Wire: ASTM A82, plain cold drawn steel.
- C. Welded Wire Reinforcement: Welded wire reinforcement shall conform to the applicable requirements of ASTM A1064. Fabric reinforcement shall be furnished in flat sheets. Fabric reinforcement in rolls will not be permitted.
- D. Supports for Reinforcement: Bolsters, chairs, and other devices for spacing, supporting, and fastening reinforcing bars, and welded wire fabric in place shall be wire bar-type supports complying with CRSI Manual
 - 1. For slabs-on-grade, use supports with sand plates or horizontal runners where base material will not support chair legs.
 - 2. For exposed-to-view concrete surfaces where legs of supports are in contact with forms, provide supports with legs that are protected by plastic (CRSI Class 1).

2.2 PORTLAND CEMENT CONCRETE

- A. Portland cement concrete shall conform to the following:
 - 1. Maximum water-cement ratio shall be 0.45 conforming to ACI 316R.
 - 2. Concrete shall be air-entrained type conforming to ASTM C94. Air content by volume shall be 6 percent + 1.5 percent, tested in accordance with ASTM C260.
 - 3. Slump of concrete shall not be less than 3 inches nor greater than 4 inches, determined in accordance with ASTM C143.
 - 4. Cement for concrete shall be a Portland cement conforming to ASTM C150, Type I or II. Only one color of cement, all by the same manufacturer, shall be used for the work.
 - 5. Fine and coarse aggregates for concrete shall conform to ASTM C33.
 - 6. Concrete shall contain a water reducing agent to minimize cement and water content of the concrete mix at the specified slump. Water reducing agent shall conform to ASTM C494, Type A.
 - 7. Concrete shall contain no calcium chloride or admixtures containing calcium chloride. No admixtures other than those specified shall be used in the concrete without the specific written permission of the Engineer.

2.3 CONCRETE AGGREGATES

- A. Fine Aggregates: Fine aggregates shall conform to ASTM C33, part 6.
- B. Coarse Aggregates: Coarse aggregates shall conform to ASTM C33, Parts 9 through 11 and Tables 2 and 3, with the following Class designations:
 - 1. Class 1S: For footings and foundations not exposed to the weather.
 - 2. Class 4S: For pavements, driveways, curbs, walkways, sidewalks, and retaining walls that are exposed to the weather.
 - 3. Class 1N: For pavements, driveways, curbs, walkways, sidewalks, and retaining walls that are not exposed to the weather.

2.4 CURING MATERIALS FOR UNCOLORED CONCRETE

- A. Curing shall be accomplished by the following methods:
 - 1. Moist curing with burlap covering.
 - 2. Curing paper, non-staining, fiber reinforced laminated Kraft bituminous product conforming to ASTM C171. Four mil polyethylene sheeting may be substituted for curing paper.
 - 3. Curing compound, a resin-base, white pigmented compound conforming to ASTM C309, Type 2.

2.5 EXPANSION JOINTS

- A. Expansion joint filler shall be performed, non-bituminous type conforming to ASTM D1752, Type II, similar to Sealtight Cork Expansion Joint Filler, manufactured by W.R. Meadows, Inc., Elgin, IL 60120, or approved equivalent.
 - 1. Pre-molded filler shall be one piece for the full depth and width of the joint.
- B. Smooth dowel shall be hot rolled plain steel dowel bonded at one end and operating in smooth close-fitting sleeve (of same material) at the other end.

2.6 CONTROL JOINTS

- A. Joints shall be tooled.

2.7 FORMS

- A. Cylindrical Forms: Sonotube Fibre Forms, wax-impregnated strippable forms manufactured by Sonoco Products Company, General Products Division, ABS or PVC plastic reusable forms, or approved equivalent.
- B. Forms for Exposed Finish: Plywood, metal, metal-framed plywood faced, or other acceptable panel materials. Plywood shall conform to U.S. Product Standard PS-1 and APA Graded B-B (Concrete Form) Class I Exterior Grade plywood or B-B or A-C Class I high density overlay concrete form plywood. Formwork materials shall produce smooth, continuous, straight and level surfaces.

- C. Forms for Unexposed Finish: Plywood, lumber, or metal, with lumber dressed on at least two edges and one side.
- D. Form Ties: Prefabricated, adjustable length galvanized steel snap-off ties, with brackets, cones, corner locks, and other accessories as necessary.
- E. Form Release Agent: Commercial formulation compounds that will not bond with, stain or adversely affect concrete.

2.8 EXPOSED CONCRETE PROTECTIVE COATING

- A. Surface sealer shall be Foxfire P-1007 or approved equivalent.

2.9 DETECTABLE WARNINGS

- A. Detectable warnings shall meet ADA and State Standards

PART 3 - EXECUTION

3.1 PREPARATION OF SUBGRADE

- A. The subgrade of areas to be paved shall be graded and compacted as specified in Section 31 00 00, EARTHWORK.
- B. Excavation required in pavement subgrade shall be completed before fine grading and final compaction of subgrade are performed. Where excavation must be performed in completed subgrade, subbase, base, or pavement, subsequent backfill and compaction shall be performed as required by the Engineer and as specified in Section 31 00 00, EARTHWORK.
- C. Materials shall not be stored or stockpiled on subgrade.
- D. Prepared subgrade will be inspected by the Engineer. Subgrade shall be approved for installation of the gravel base course. Disturbance to subgrade caused by inspection procedures shall be repaired.

3.2 BASE COURSE

- A. Base course for concrete paving shall be pavement subbase course or gravel base materials specified in Section 31 00 00 EARTHWORK as shown on the Drawings.
- B. Width of base course shall extend beyond edge of the proposed pavement as shown on the Drawings.
- C. Material shall be placed in lifts no more than 6 inches thick, compacted measure. Each lift shall be separately compacted to specified density.
 - 1. Material shall be placed adjacent to wall, manhole, catch basin, and other structures only after they have been set to required grade.

2. Rolling shall begin at sides and progress to center of crowned areas and shall begin on low side and progress toward high side of sloped areas. Rolling shall continue until material does not creep or wave ahead of roller wheels.
 3. Surface irregularities which exceed 1/2 inch as measured by means of a 10-foot-long straightedge shall be regraded and recompact.
- D. Base course shall be compacted at optimum moisture content to not less than 95 percent of maximum density as determined by ASTM D1557.
- E. The base course shall be kept clean and uncontaminated. Less select materials shall not be permitted to become mixed with the base course material.

3.3 STEEL REINFORCEMENT

- A. Before being placed in position, reinforcing steel shall be thoroughly cleaned of loose mill and rust scale, dirt, ice, and other foreign material which may reduce the bond between the concrete and reinforcing. Where there is delay in placing concrete after reinforcement is in place, bars shall be re-inspected and cleaned when required.
- B. Any bar showing cracks after bending shall be discarded.
- C. Unless otherwise shown on the Drawings, reinforcing shall extend within 2 inches of formwork and expansion joints. Reinforcing shall continue through control joints. Adjacent sheets of fabric reinforcing shall lap 6 inches.
- D. After forms have been coated with form release agent, but before concrete is placed, reinforcing steel shall be securely wired in the required position and shall be maintained in that position until concrete is placed and compacted. Chair bars and supports shall be installed in a number and arrangement approved by the Engineer.

3.4 FORMS

- A. General: Design, erect, support, brace, and maintain formwork to support vertical, lateral, static, and dynamic loads that might be applied until concrete structure can support such loads. Construct formwork so concrete members and structures are of correct size, shape, alignment, elevation, and position. Maintain formwork construction tolerances and surface irregularities complying with the following ACI 347 limits.
1. Provide Class A tolerances for concrete surfaces exposed to view.
 2. Provide Class C tolerances for other concrete surfaces.
- B. Construct forms to provide for openings, offsets, sinkage's, keyways, recesses, moldings, chamfers, blocking, screeds, bulkheads, anchorages, and inserts, and other features required for the work. Use selected materials to obtain required finishes. Solidly butt joints and provide back-up at joints to prevent cement paste from leaking.
- C. Fabricate forms for easy removal without hammering or prying against concrete surfaces. Kerf wood inserts for forming keyways, reglets, recesses, and other features for easy removal.

- D. Chamfer exposed corners and edges, using wood, metal, PVC, or rubber chamfer strips fabricated to produce uniform smooth lines and tight edge joints.
- E. Thoroughly clean forms and adjacent surfaces to receive concrete. Remove chips, wood, sawdust, dirt, or other debris just before placing concrete. Re-tighten forms and bracing before placing concrete, as required, to prevent mortar leaks and maintain proper alignment.

3.5 INSTALLING EMBEDDED ITEMS

- A. General: Set and build into formwork the anchorage devices and other embedded items required for work that is attached to, or supported by, cast-in-place concrete. Use setting drawings, diagrams, instructions, and directions provided by suppliers of items to be attached.
- B. Forms for Slabs: Set edge forms, bulkheads, and intermediate screed strips for slabs to achieve required elevations and contours in finished surfaces. Provide and secure units to support screed strips using strike-off templates or compacting-type screeds.

3.6 PREPARING FORM SURFACES

- A. Coat contact surfaces of forms with an approved, non-residual, low-VOC form-coating compound before placing reinforcement.

3.7 CONCRETE PLACING

- A. Equipment, methods of mixing and placing, and precautions to be observed as to weather, and condition of base shall meet the requirements of ACI 316R.
- B. The Engineer shall be notified of scheduled concrete placement sufficiently in advance of start of operation to allow preliminary inspection of the work, including subgrade, forms, and reinforcing steel.
- C. Work shall not be performed during rainy weather or when temperature is less than 40°F. (4.4°C.).
- D. Adjacent work shall be protected from stain and damage. Damaged and stained areas shall be replaced or repaired to equal their original conditions.
- E. Existing concrete, earth, and other water-permeable material against which new concrete is to be placed shall be thoroughly damp when concrete is placed. There shall be no free water on surface.
- F. Concrete which has set or partially set, before placing shall not be used. Retempering of concrete will not be permitted.
- G. Concrete shall be thoroughly vibrated, or otherwise consolidated to secure a solid and homogeneous mass, thoroughly worked around reinforcement and into corners of forms.

- H. When joining fresh concrete to concrete which has attained full set, latter shall be cleaned of foreign matter, and mortar laitance shall be removed by chipping and washing. Clean, roughened base surface shall be saturated with water, but shall have no free water on surface. A coat of 1:1 cement-sand grout, approximately 1/8 inch thick, shall be well scrubbed into the thoroughly dampened concrete base. New concrete shall be placed immediately, before grout has dried or set.

3.8 FINISHING

- A. Concrete surfaces shall be screeded and finished true to line and grade, and free of hollows and bumps. Surface shall be dense and smooth.
 - 1. Finished concrete surface for concrete subbases shall be wood floated to a slightly rough surface. Surface shall not deviate more than 1/4 inch in 10 feet.
 - 2. Finished concrete surfaces shall be wood floated and steel troweled, or broom finished, to a uniform surface. Surface shall not deviate more than 1/8 inch in 10 feet.
- B. Horizontal surfaces of concrete surfaces which will be exposed shall be given a light broomed finish, with direction of grooves in concrete surface perpendicular to length of concrete band, slab, or pad. After concrete has set sufficiently to prevent coarse aggregate from being torn from surface, but before it has completely set, brooms shall be drawn across the surface to produce a pattern of small parallel grooves. Broomed surface shall be uniform, with no smooth, unduly rough, or porous spots, or other irregularities. Coarse aggregate shall not be dislodged by brooming operation.
- C. Immediately following finishing operations, arises at edges and both sides of expansion joints shall be rounded to a 1/4- inch radius. Control joints to be tooled shall be scored into slab surface with scoring tool. Adjacent edges of control joint shall at same time be finished to a 1/4- inch radius.
- D. Where finishing is performed before end of curing period, concrete shall not be permitted to dry out, and shall be kept continuously moist from time of placing until end of curing period, or until curing membrane is applied.
- E. Sidewalks, walkways, accessible routes, and ramps shall be constructed and finished in accordance with the Americans with Disabilities Act (ADA) and state and local requirements. Provide protective coating in accordance with manufacturer's recommendations.

3.9 CURING

- A. Concrete shall be kept continuously damp from time of placement until end of specified curing period or cured by other methods. Water shall not be added to surface during floating and troweling operations, and not earlier than 24 hours after concrete placement. Between finishing operations, surface shall be protected from rapid drying by a covering of waterproofing paper. Surface shall be damp when the covering is placed over it, and shall be kept damp by means of a fog spray of water, applied as often as necessary to prevent drying, but not sooner than 24 hours after placing concrete. None of the water so applied shall be troweled or floated into surface.
- B. Concrete surfaces shall be cured by completely covering with curing paper or application of a curing compound.

1. Concrete cured using waterproof paper shall be completely covered with paper with seams lapped and sealed with tape. Concrete surface shall not be allowed to become moistened between 24 and 36 hours after placing concrete. During curing period, concrete surface shall be checked frequently, and sprayed with water as often as necessary to prevent drying, but not earlier than 24 hours after placing concrete.
 2. Concrete cured with a curing compound shall have the compound applied at a rate of 200 square feet per gallon, in two applications perpendicular to each other.
 3. Curing period shall be seven (7) days minimum.
- C. Only if additional protection is absolutely required, the surface should remain uncovered after the seven (7) day period for at least four (4) days, after which time new and unwrinkled non-staining reinforced waterproof Kraft curing paper may be used.

3.10 EXPANSION JOINTS

- A. Expansion joints shall be 1/2-inch-wide and located to provide a maximum spacing of 20 feet between joints or where shown on the Drawings. Expansion joints shall be troweled in the concrete to required width with preformed joint filler in place. Joint filler shall extend the full depth of the slab and full length of the expansion joint.
1. For concrete walks, pavements, and pads, depth of joint filler shall be placed to form a 1-1/4-inch-deep recess for sealant and backer rod below finished concrete surface.
 2. Use of multiple pieces to make up required depth and width of joint will not be permitted.

3.11 CONSTRUCTION JOINTS

- A. Construction joints shall be placed whenever placing of concrete is suspended for more than 30 minutes.
1. Butt joint with dowels or use a thickened edge joint if construction joints occur at control joint locations.
 2. Keyed joints with tie-bars shall be used if the joint occurs at any other location.

3.12 CONTROL JOINTS

- A. Control joints shall be tooled into the concrete slab, with 3-inch-wide border and troweled edges, in pattern as shown on the Drawings. Score joints shall be tooled, brushed, and tooled again to create "window pane" aesthetic.
- B. Scoring shall cut into slab surface at least 1 inch, but in no case not less than 25 percent of slab depth.

3.13 PROTECTIVE COATING

- A. Sealant shall be applied per manufacturer's recommendations.

3.14 COLD WEATHER CONCRETING

- A. Materials for concrete shall be heated when concrete is mixed, placed, or cured when the mean daily temperature is below 40°F. or is expected to fall to below 40°F. within 72 hours. The concrete, after placing, shall be protected by covering, heat, or both.
- B. Details of handling and protecting of concrete during freezing weather shall be subject to the approval and direction of the Engineer. Procedures shall be in accordance with provisions of ACI 306R.

3.15 HOT WEATHER CONCRETING

- A. Concrete just placed shall be protected from the direct rays of the sun and the forms and reinforcement just prior to placing shall be sprinkled with cold water. Every effort shall be made to minimize delays which will result in excessive mixing of the concrete after its arrival on-site.
- B. During periods of excessively hot weather (95°F., or above), ingredients in the concrete shall be cooled with cold mixing water to maintain the temperature of the concrete at permissible levels in accordance with the provisions of ACI 305R. Any concrete with a temperature above 95°F., when ready for placement, will be rejected.
- C. Temperature records shall be maintained throughout the period of hot weather giving air temperature, general weather conditions (calm, windy, clear, cloudy, etc.) and relative humidity. Records shall include checks on temperature of concrete when delivered to Project site and after placing in forms. Data should be correlated with the progress of the work so that conditions surrounding the construction of any part of the structure can be ascertained.

3.16 PROTECTION OF CONCRETE SURFACES

- A. Concrete surfaces shall be protected from traffic or damage until surfaces have hardened sufficiently.

3.17 DETECTABLE WARNINGS

- A. Detectable warnings shall be cast iron 'dome stamp' pattern and shall be installed at locations as shown and as detailed on plans and per manufacturer's recommendations.
- B. Detectable warning plates shall be cast iron, unless otherwise approved by Owner.
- C. Detectable warning plates shall be Cast Iron Detectable Warning Surface Plates by ADA Solutions, 323 Andover Street, Suite 3, Wilmington, MA, 01887 (800-372-0519, sales@adatile.com, www.adatile.com.), or approved equal.

END OF SECTION 03 30 55

SECTION 03 35 43

POLISHED CONCRETE FLOOR FINISHING

PART 1 – GENERAL

1.01 SECTION INCLUDES

- A. Penetrating Liquid Floor Treatment for Polished Concrete Finishes: Colored, chemically reactive solution of silicate material and proprietary components, odorless, that penetrates, hardens and is suitable for Polished Concrete surfaces leaving no surface film.
- B. Listed on drawings as SC1 through SC10

1.02 RELATED SECTIONS

- A. Division 3 – Cast-in-place Concrete

1.03 REFERENCE STANDARDS

- A. ASTM C-642-06 Standard Test Method for Density, Absorption, and Voids in Hardened Concrete
- B. ASTM D-5178-98/08 Standard Test Method for Mar Resistance of Organic Coatings
- C. ASTM D-4060-07 Standard Test Method for Abrasion Resistance of Organic Coatings by the Taber Abrasion: Modified
- D. ASTM G-154-06 Standard Practice for Operating Fluorescent Light Apparatus for UV Exposure of Nonmetallic Materials
- E. ASTM D-2369-07 Standard Test Method for Volatile Content of Coatings
- F. ASTM D-2047-04 Standard Test Method for Static Coefficient of Friction of Polish-Coated Flooring Surfaces as Measured by the James Machine
- G. Reflectivity according to use of Horiba IG-320 Gloss Checker
- H. ASTM C-1378-04 (2009) Standard Test Method for Determination of Resistance to Staining
- I. ANSI Standard B-101.1-2009 – Manufacturer required to have letter certifying compliance.

1.04 ADMINISTRATIVE REQUIREMENTS

- A. Schedule and hold a pre-installation meeting prior to project start.
 - 1. To attend: Architect, Owners Representative, General Contractor, Certified Installer.

- B. Schedule installation and review date for mock-up.

1.05 SUBMITTALS

- A. Submit under provisions of Section 01 33 00.
- B. MSD Sheet indicating VOC content and safety precautions.
- C. Manufacturer's Quality Assurance: Submit manufacturer's certification that floor treatment complies with specified requirements and is suitable for intended application.
- D. Warranty: Submit manufacturer's standard warranty.
- E. LEED: Submit manufacturer's LEED Certification.
- F. Applicator Qualifications: Submit list of projects reference as documented in this Specification under Quality Assurance Section.
- G. Quality Control Submittals: Provide protection plan of surrounding areas and non-work surfaces.
- H. Product Data: Provide data on all products, including information on compatibility of different products and limitation.
- I. Indicate installation procedures and interface required with adjacent construction.
- J. Provide Manufacturers Maintenance Instructions.

1.06 INFORMATIONAL SUBMITTALS

- A. Quality Assurance:
 - 1. Certificates
 - a. Product certificates signed by the manufacturer certifying materials comply with specified performance characteristics and criteria and physical requirements.
 - b. Current contractor's certificate signed by the manufacturer declaring contractor as a certified and approved installer of the polishing system.
- B. Qualifications:
 - 1. Installer certified by manufacturer and experienced in performing work of this section who has specialized in installation of work similar to that required for this project.
 - 2. Manufacturer: Products that may be incorporated into the work must have 5 years of recognized polishing use on jobs of similar scope.
- C. Pre-installation Conference: Conduct a pre-installation meeting to verify project requirements, manufacturer's installation instructions and manufacturer's warranty requirements.

1.07 MOCK-UP

- A. Installation: Provide an 8' x 8' test area of finished, colored, polished floor.

- B. Mock-up will be used to evaluate concrete substrate preparation, material application, and shine.
- C. When approved, Mock-up will demonstrate minimum standard of quality required for proceeding with this work.
- D. Approved Mock-up shall remain for comparison as part of the finished work.

1.08 DELIVERY, STORAGE, AND HANDLING

- A. Deliver, store, protect and handle products to site under provisions of Section 01 60 00.
- B. Store material in dry, enclosed area protected from exposure to moisture and temperatures below 50° F.
- C. Keep containers closed and upright to prevent leakage.
- D. Dispense special concrete finish material from factory numbered and sealed containers.
- E. Maintain record of lot numbers.

1.09 PROJECT CONDITIONS

- A. Protect concrete slabs from staining prior to application of concrete finish system.
- B. Diaper hydraulic powered equipment.
- C. Place drop cloths under parked vehicles.
- D. Do not store structural steel or metal fabrications on slab.
- E. Do not allow pipe-cutting machine on slab.

1.10 REGULATORY REQUIREMENTS

- A. Conform to all applicable Federal, State and local codes and laws.

1.11 WARRANTY

- A. Certi-Shine MicroStain: Provide 10 year manufacturer's material warranty commencing at date of building substantial completion. Manufacturer shall warrant to the owner that polished surface will remain water repellent, dustproof, hardened, abrasion and food stain resistant. Submit under the provisions of Section 01780.

PART 2 - PRODUCTS

2.01 MANUFACTURERS

- A. Vexcon Chemicals.
 - 1. Contact Brand Manager 1-888-VEXCON-1
Fax 215-332-9997

7240 State Rd.
Phila., PA 19135
E-mail: techservice@vexcon.com
www.vexcon.com

- B. Basis of Design: Subject to compliance with requirements, provide Vexcon Chemicals system Certi-Shine MicroStain.
- C. Substitutions: Under provisions of Section 01 60 00.

2.02 SYSTEM DESCRIPTION

- A. Polished Concrete: Includes grinding installation of silicate sealer, (hardener, densifier), polishing, and a stain repellent.
- B. Performance Criteria: Polishing systems shall have the following minimum performance properties:
 - 1. ASTM C-642 Absorption: Reduction of 75% of Control
 - 2. ASTM D-5178 Balance Beam Mar Tester: Greater than 50% harder
 - 3. ASTM D-4060 Modified Taber Abrasion 600 Rev:0.37% treated vs. 0.68% untreated
 - 4. ASTM G-154: 5000 HR QUV: No fade, change or erosion
 - 5. ASTM D-2369 Solids: 18% Minimum
 - 6. ASTM D-2047 Coefficient of Friction:
 - a. Certi-Shine Finish Coat Ultra - average - 0.63
 - 7. Reflectivity: Change in gloss to 60 [Gold] as measured using a gloss meter in accordance with Horiba IG-320 Gloss Checker.
 - 8. ASTM C-1378 Stain resistance: Food, Chemical, Oil and common stain resistance. See manufacturer's literature for list.
 - 9. ANSI B-101.1-2009 Non-slip properties – High Traction Rating

2.03 PRODUCTS/SYSTEM

- A. Penetrating Liquid Floor Treatment for Polished Concrete Finishes: Chemically reactive, water borne solution of silicate material and proprietary components, odorless, that penetrates, hardens and is suitable for Polished Concrete surfaces leaving no surface film.
 - 1. Acceptable Material: Vexcon Chemicals, Certi-Shine MicroStain.
- B. Unreacted Silicate Rinse: Liquid rinse solution, increases stain resistance.
 - 1. Acceptable Material: Vexcon Chemicals, Certi-Shine Fixative.
- C. Stain Repellent (non-film forming): Ready to use, food (oil and acid), hydraulic fluid and motor oil stain and water repellent, Silane and Silane polymer blend.
 - 1. Acceptable Material: Vexcon Chemicals, Certi-Shine Finish Coat Ultra WB
- D. Concrete Stain: Vibrant colors, UV resistant, Zero VOC, Silicate Micro-Stain, chemically bonds with the concrete, formulated for use on polished concrete.
 - 1. Acceptable Material: Vexcon Chemicals, Certi-Shine MicroStain.
 - 2. Colors to be selected by Architect from manufacturer's standard colors.
Unlimited number of colors per project.

- E. Silicate floor repair material: Liquid silicate material which fills and repairs concrete surface imperfections.
 - 1. Acceptable Material: Vexcon Chemical, Certi-Shine Fusion.
- F. Cleaning Solution: Eco-friendly degreaser and cleaner, concentrate pH must be slightly alkaline.
 - 1. Acceptable Material: Vexcon Chemicals, StarSeal EF Degreaser and Cleaner.
- G. Finishing Gloss Level Standard:
 - 1. Medium shine [Gold], equivalent to 60° film gloss of 60 when viewed at an angle

PART 3 - EXECUTION

3.01 EXAMINATION

- A. Site Verification of Concrete Conditions
 - 1. Installer and manufacturer's representative will examine surfaces receiving concrete finish and polishing system.
 - a. Verify that surfaces conform to product manufacturer's requirements for substrate conditions.
 - b. Verify floor is free of curing membrane, bond-breaker, concrete laitance, and will absorb water per water absorbency test.
- B. Concrete slab performance requirements
 - 1. Verify that all the concrete complies with finishing requirements as specified in the Division 3 Cast In Place Concrete specification section.

3.02 CONCRETE PREPARATION

- A. Complete surface preparation per manufacturers written instructions.
- B. Power sweep floor area, blow out corners and column footings.
- C. Initial grind should clean the concrete surface, removing all coatings, dirt, oil and laitance.
- D. If grinding does not remove oil spots, treat oil spots with emulsifier and oil absorber materials. Detail scrub with high pH detergent.
 - 1. Acceptable Material: Vexcon Chemicals, StarSeal EF Stripper
- E. Double scrub floor with automatic scrubber capable minimum of 80 to 120 pounds of head pressure, equipped with black stripping pads. Use proper dilution of high pH detergent. Scrub floor once without squeegee or vacuum. On second pass, remove water solution.
- F. Power rinse surface removing all traces of soap residue.
- G. Inspect the concrete surface.
- H. Complete surface preparation per manufacturers written instructions.

- I. Perform water absorbency test.
 - 1. Repeat any steps as necessary to prepare for polishing.

3.03 CONCRETE FINISH APPLICATION AND POLISHING

- A. Immediately following cleaning operation, install concrete polishing materials per manufacturer's instructions.
- B. Perform polishing operation to the specified polish level.
 - 1. Polishing Levels for Certi-Shine products
 - a. [Gold] - Medium Shine - Equivalent to 60° film gloss of 60 when viewed on an angle.

3.04 JOINT FILLER

- A. Prime and fill with manufacturer's approved epoxy joint sealant those joints that require the application of joint sealant after the application of the finishing system or as directed by the manufacturer.
 - 1. Powercoat Primer
 - 2. Powercoat Flexible Epoxy Joint Sealant

3.05 CLEANING & PROTECTION

- A. Clean under provisions of Section 01 70 00.
- B. Protect finished surfaces from damage and soiling and other construction activities.
- C. Without damaging completed work, provide protective cover.

END OF SECTION

SECTION 03 35 49

CONCRETE FLOOR SEALER

PART 1 - GENERAL

1.1 SUMMARY

- A. Related Documents:
The Drawings and general provisions of the Contract, including General and Supplementary General Conditions, and Division 1 Requirements, apply to the work in this Section.

1.2 SECTION INCLUDES

- A. Liquid concrete floor sealers.

1.3 RELATED REQUIREMENTS

- A. Section 03 30 00 – Cast-in-Place Concrete.

1.4 SUBMITTALS

- A. Comply with Section 01 33 00 – Submittal Procedures.
- B. Product Data: Submit manufacturer's product data, including surface preparation and application instructions.
- C. Manufacturer's Certification: Submit manufacturer's certification that materials comply with specified requirements and are suitable for intended application.
- D. Warranty Documentation: Submit manufacturer's warranties.

1.5 QUALITY ASSURANCE

- A. Manufacturer's Qualifications: Manufacturer regularly engaged, for past 5 years, in manufacture of liquid concrete floor sealers of similar type to that specified.
- B. Applicator's Qualifications:
 - 1. Applicator regularly engaged, for past 5 years, with documented experience in application of liquid concrete floor sealers of similar type to that specified.
 - 2. Employ persons certifiably trained for application of liquid concrete floor sealers.
 - 3. Approved by sealer manufacturer.
- C. Site Test Application: If requested by the Architect, provide a construction site test application of liquid concrete floor sealers for evaluation of surface preparation techniques and application workmanship.
 - 1. Construction site test application using same materials proposed for use in the Work.
 - 2. Construction site test application at locations determined by Architect.
 - 3. Do not proceed until workmanship of site test application is approved by Architect.

4. Approved Site Test Application: Standard for workmanship of liquid concrete floor sealers.

D. Preinstallation Meeting:

1. Convene preinstallation meeting 2 weeks before start of application of liquid concrete floor sealers.
2. Require attendance of parties directly affecting work of this section, including Contractor, Architect, applicator, and manufacturer's representative.
3. Review surface preparation, mixing, application, protection, and coordination with other work.

1.6 DELIVERY, STORAGE, AND HANDLING

- A. Delivery and Acceptance Requirements: Deliver materials to site in manufacturer's original, unopened containers and packaging, with labels clearly identifying product name and manufacturer.

B. Storage and Handling Requirements:

1. Store and handle materials in accordance with manufacturer's instructions.
2. Keep materials in manufacturer's original, unopened containers and packaging until application.
3. Store liquid concrete floor sealers between 50 and 80 degrees F.
4. Store materials in clean, dry area indoors, out of direct sunlight.
5. Protect materials from freezing.
6. Protect materials during storage, handling, and application to prevent contamination or damage.

1.7 ENVIRONMENTAL REQUIREMENTS

- A. Substrate and Ambient Temperatures: Apply liquid concrete floor sealers at substrate and ambient temperatures between 50 and 90 degrees F.
- B. Do not apply liquid concrete floor sealers in direct sunlight.

1.8 WARRANTY

- A. Manufacturer's Warranty: Standard manufacturer's warranty with a minimum of one year.
- B. Submit under the provisions of Section 01 78 00.

PART 2 PRODUCTS

2.1 MANUFACTURER

- A. Subject to compliance with requirements of this Specification Section, provide products listed herein from one of the following:
1. V-Seal Concrete Sealers and Specialty Coatings
 2. Surface Coatings, Inc.
 3. GhostShield

- B. Basis of Design: V-Seal Concrete Sealers and Specialty Coatings
 - 1. V-Seal 101
 - 2. V-Seal Phase II

2.2 MATERIALS

- A. V-Seal 101 curing/sealer manufactured by V-Seal (for smooth interior concrete slab finish)
 - 1. Description: Reactive penetrating cure and sealer.
 - 2. Color: Clear
- B. V-Seal Phase II sealer manufactured by V-Seal
 - 1. Description: Penetrating sealer.
 - 2. Color: Clear

PART 3 - EXECUTION

3.1 EXAMINATION

- A. Examine concrete surfaces to receive liquid concrete floor sealers.
- B. Notify Architect of conditions that would adversely affect application.
- C. Do not begin surface preparation or application until unacceptable conditions are corrected.

3.2 PREPARATION

- A. Protection of In-Place Conditions: Protect adjacent surfaces, glass, aluminum, steel, and vegetation from contact with liquid concrete floor sealers.
- B. Surface Preparation of Concrete:
 - 1. Prepare surfaces in accordance with sealer manufacturer's instructions.
 - 2. Clean concrete surfaces of dirt, dust, debris, oil, grease, bond-breaker compounds, curing compounds, sealers, laitance, paint, and other contaminants which could adversely affect liquid concrete floor sealer penetration.

3.3 MIXING

- A. Mix materials in accordance with manufacturer's instructions.

3.4 APPLICATION

- A. For curing new concrete apply one coat V-SEAL 101 after all bleed water is gone, finishing is complete and the concrete will withstand the weight of a person and not be marred. Always test porosity prior to application. Surface must be porous and free of loose debris, mildew, topical oil, paint or other surface coatings. Surface should be dry (no standing water). Apply uniformly with roller or low pressure sprayer. Actual application rate based upon substrate porosity and absorption. Product should create a slightly white surface sheen and absorb within 1 minute without puddles. Puddles should be immediately dispersed as excessive application may result in white residue which will not affect sealer performance and generally dissipates over time or power washing.

- B. Apply one coat of V-SEAL Phase II to substrates previously cured/sealed with V-SEAL 101 minimum of 7 days following 101 application. Always test small area for porosity. All surfaces to be treated must be clean and sound. Remove all membrane forming oil, grease, dirt and other contaminants. Apply Phase II to point of rejection by roller. Work-in to a manageable area with a mechanical scrubber. Thoroughly remove excess material to avoid chalk residue. Ponded or puddled material should be squeegeed, brushed, or removed, otherwise white residue may appear on the surface. If white residue starts to appear on the surface during drying, immediately remove with hot water and scrubbing. Surfaces may be slippery during application.

3.5 CLEANING

- A. Clean under provisions of Section 01 70 00.
- B. Wash application materials with warm water.

3.6 PROTECTION

- A. Do not permit traffic on floor for a minimum period of 24 hours.
- B. Protect sealed concrete floor from damage during construction.

END OF SECTION

SECTION 04 22 24

REINFORCED MASONRY

(NON-LOAD BEARING INTERIOR PARTITIONS)

PART 1 - GENERAL

1.01 RELATED DOCUMENTS

- A. Drawings and general provisions of the Contract, including General and Supplementary Conditions and Division 1 Specification Sections, apply to this Section.

1.02 SUMMARY

- A. This Section includes unit masonry assemblies consisting of the following:
 - 1. Concrete masonry units. (To be incorporated in non-load bearing interior partitions)
 - 2. Mortar and grout.
 - 3. Reinforcing steel.
 - 4. Masonry joint reinforcement.
 - 5. Ties and anchors.
 - 6. Miscellaneous masonry accessories.
- B. Products furnished, but not installed, under this Section include the following:
 - 1. Adjustable masonry anchors welded to structural steel frame.
- C. Products installed, but not furnished, under this Section include the following:
 - 1. Steel lintels for unit masonry.
 - 2. Steel door frame anchors.

1.03 RELATED SECTIONS

- A. Related Sections include the following:
 - 1. Section 03 30 00 - Cast-in-Place Concrete
 - 2. Section 04 22 13 – Concrete Unit Masonry
 - 3. Section 05 50 00 - Miscellaneous Metal Work
 - 4. Section 07 84 13 – Firestopping
 - 5. Section 07 92 13 – Joint Sealants
 - 6. Section 08 12 13 – Steel Door Frames

1.04 PERFORMANCE REQUIREMENTS

- A. Provide unit masonry that develops the following net-area compressive strengths (f_m) at 28 days. Determine compressive strength of masonry by testing masonry prisms according to ASTM C 1314.
 - 1. For Concrete Unit Masonry: $f_m = 1500$ psi.
- B. Masonry Grout: 2000 psi compressive strength at 28 days.

1.05 SUBMITTALS

- A. Comply with provisions of Section 01 33 00.
- B. Product Data: For each different masonry unit, accessory, and other manufactured product specified.
- C. Shop Drawings: Show fabrication and installation details for the following:
 - 1. Reinforcing Steel: Detail bending and placement of unit masonry reinforcing bars. Comply with ACI 315, "Details and Detailing of Concrete Reinforcement." Show elevations of reinforced walls.
- D. Samples for Verification: For the following:
 - 1. Full-size units for each different exposed masonry unit required, showing the full range of exposed colors, textures, and dimensions to be expected in the completed construction.
 - 2. Colored mortar: Samples for each color required, showing the full range of colors expected in the finished construction. Make samples using the same sand and mortar ingredients to be used on Project. Label Samples to indicate types and amounts of pigments used.
 - 3. Accessories embedded in the masonry.
- E. Qualification Data: For firms and persons specified in "Quality Assurance" Article.
- F. Material Test Reports: From a qualified testing agency indicating and interpreting test results of the following for compliance with requirements indicated:
 - 1. Each type of masonry unit required.
 - a. Include size-variation data for cmu, verifying that actual range of sizes falls within specified tolerances.
 - b. Include test results, measurements, and calculations establishing net-area compressive strength of masonry units.
 - 2. Mortar complying with property requirements of ASTM C 270.
 - 3. Grout mixes complying with compressive strength requirements of ASTM C 476. Include description of type and proportions of grout ingredients.
- G. Material Certificates: Signed by manufacturers certifying that each of the following items complies with requirements:
 - 1. Each type of masonry unit required.
 - a. Include size-variation data for cmu, verifying that actual range of sizes falls within specified tolerances.
 - b. Include test data, measurements, and calculations establishing net-area compressive strength of masonry units.
 - 2. Each cement product required for mortar and grout, including name of manufacturer, brand, type, and weight slips at time of delivery.
 - 3. Each combination of masonry unit type and mortar type. Include statement of net-area compressive strength of masonry units, mortar type, and net-area compressive strength of masonry determined according to Tables 1 and 2 in ACI 530.1/ASCE 6/TMS 602.
 - 4. Each material and grade indicated for reinforcing bars.
 - 5. Each type and size of joint reinforcement.
 - 6. Each type and size of anchor, tie, and metal accessory.

1.06 QUALITY ASSURANCE

- A. Comply with provisions of Section 01 45 00.
- B. Testing Agency Qualifications: An independent testing agency, acceptable to authorities having jurisdiction, qualified according to ASTM C 1093 to conduct the testing indicated, as documented according to ASTM E 548.
- C. Source Limitations for Masonry Units: Obtain exposed masonry units of a uniform texture and color, or a uniform blend within the ranges accepted for these characteristics, through one source from a single manufacturer for each product required.

- D. Source Limitations for Mortar Materials: Obtain mortar ingredients of a uniform quality, including color for exposed masonry, from one manufacturer for each cementitious component and from one source or producer for each aggregate.
 - E. Preconstruction Testing Service: Engage a qualified independent testing agency to perform the following preconstruction testing:
 - 1. Concrete Masonry Unit Test: For each concrete masonry unit indicated, per ASTM C 140.
 - 2. Prism Test: For each type of wall construction indicated, per ASTM C 1314.
 - 3. Mortar Test: For mortar properties per ASTM C 270.
 - 4. Grout Test: For compressive strength per ASTM C 1019.
 - F. Fire-Resistance Ratings: Where indicated, provide materials and construction identical to those of assemblies with fire-resistance ratings determined per ASTM E 119 by a testing and inspecting agency, by equivalent concrete masonry thickness, or by another means, as acceptable to authorities having jurisdiction.
- 1.07 DELIVERY, STORAGE, AND HANDLING
- A. Comply with Section 01 60 00.
 - B. Store masonry units on elevated platforms in a dry location. If units are not stored in an enclosed location, cover tops and sides of stacks with waterproof sheeting, securely tied. If units become wet, do not install until they are dry.
 - 1. Protect Type I concrete masonry units from moisture absorption so that, at the time of installation, the moisture content is not more than the maximum allowed at the time of delivery.
 - C. Store cementitious materials on elevated platforms, under cover, and in a dry location. Do not use cementitious materials that have become damp.
 - D. Store aggregates where grading and other required characteristics can be maintained and contamination avoided.
 - E. Deliver preblended, dry mortar mix in moisture-resistant containers designed for lifting and emptying into dispensing silo. Store preblended, dry mortar mix in delivery containers on elevated platforms, under cover, and in a dry location or in a metal dispensing silo with weatherproof cover.
 - F. Store masonry accessories, including metal items, to prevent corrosion and accumulation of dirt and oil.
- 1.08 PROJECT CONDITIONS
- A. Protection of Masonry: During construction, cover tops of walls, projections, and sills with waterproof sheeting at end of each day's work. Cover partially completed masonry when construction is not in progress.
 - 1. Extend cover a minimum of 24 inches down both sides and hold cover securely in place.
 - B. Stain Prevention: Prevent grout, mortar, and soil from staining the face of masonry to be left exposed or painted. Immediately remove grout, mortar, and soil that come in contact with such masonry.
 - 1. Protect base of walls from rain-splashed mud and from mortar splatter by coverings spread on ground and over wall surface.
 - 2. Protect sills, ledges, and projections from mortar droppings.
 - 3. Protect surfaces of window and door frames, as well as similar products with painted and integral finishes, from mortar droppings.
 - 4. Turn scaffold boards near the wall on edge at the end of each day to prevent rain from splashing mortar and dirt onto completed masonry.
 - C. Cold-Weather Requirements: Do not use frozen materials or materials mixed or coated with ice or frost. Do not build on frozen substrates. Remove and replace unit masonry damaged by frost or by freezing conditions. Comply with cold-weather construction requirements contained in ACI 530.1/ASCE 6/TMS 602.

1. Cold-Weather Cleaning: Use liquid cleaning methods only when air temperature is 40 deg F and above and will remain so until masonry has dried, but not less than 7 days after completing cleaning.
 - D. Hot-Weather Requirements: Protect unit masonry work when temperature and humidity conditions produce excessive evaporation of water from mortar and grout. Provide artificial shade and wind breaks and use cooled materials as required. Comply with hot-weather construction requirements contained in ACI 530.1/ASCE 6/TMS 602.
 1. When ambient temperature exceeds 100 deg F, or 90 deg F with a wind velocity greater than 8 mph, do not spread mortar beds more than 48 inches ahead of masonry. Set masonry units within one minute of spreading mortar.
- 1.09 REFERENCE STANDARDS
- A. ACI 530/ASCE 5/TMS 402: Building Code Requirements for Masonry Structures
 - B. ACI 530.1/ASCE 6/TMS 602: Specification for Masonry Structures
 - C. ASTM A82: Standard Specification for Steel Wire, Plain, for Concrete Reinforcement
 - D. ASTM C90: Standard Specification for Load bearing Concrete Masonry Units
 - E. ASTM C144: Standard Specification for Aggregate for Masonry Mortar
 - F. ASTM C150: Standard Specification for Portland Cement
 - G. ASTM C207: Standard Specification for Hydrated Lime for Masonry Purposes
 - H. ASTM C270: Standard Specification for Mortar for Unit Masonry
 - I. ASTM C404: Standard Specification for Aggregates for Masonry Grout
 - J. ASTM C476: Standard Specification for Grout for Masonry
 - K. ASTM C780: Standard Test Method for Preconstruction and Construction Evaluation of Mortars for Plain and Reinforced Unit Masonry
 - L. ASTM C1019: Standard Test Method for Sampling and Testing Grout
 - M. ASTM C1314: Standard Test Method for Compressive Strength of Masonry Prisms
 - N. AWS D1.4: American Welding Society Structural Welding Code – Reinforcing Steel

PART 2 - PRODUCTS

- 2.01 CONCRETE MASONRY UNITS
- A. General: Provide shapes indicated and as follows:
 1. Provide special shapes for lintels, corners, jambs, sash, control joints, headers, bonding, and other special conditions.
 2. Provide bullnose units for outside corners, unless otherwise indicated.
 - B. Concrete Masonry Units (Decorative and Standard): ASTM C 90
 1. Unit Compressive Strength: Provide units with minimum average net-area compressive strength of 1900 psi.
 2. Weight Classification: Normal weight, unless otherwise indicated.
 3. Provide Type I, moisture-controlled units.
 - C. Color
 1. Exposed concrete block to be painted as specified in Section 09 91 00 – Painting. Color to be selected by Architect from manufacturer's standard colors.
 - D. Finish
 1. Exposed faces are to be smooth faced.
- 2.02 MORTAR AND GROUT MATERIALS
- A. Portland Cement: ASTM C 150, Type I or II, except Type III may be used for cold-weather construction. Provide natural color or white cement as required to produce mortar color indicated.
 - B. Hydrated Lime: ASTM C 207, Type S.

- C. Portland Cement-Lime Mix: Packaged blend of portland cement complying with ASTM C 150, Type I or Type III, and hydrated lime complying with ASTM C 207.
 - D. Mortar Cement: ASTM C 1329.
 - E. Masonry Cement: ASTM C 91.
 - F. Aggregate for Mortar: ASTM C 144; except for joints less than 1/4 inch thick, use aggregate graded with 100 percent passing the No. 16 sieve.
 - G. Aggregate for Grout: ASTM C 404.
 - H. Mortar Pigments: Natural and synthetic iron oxides and chromium oxides, compounded for use in mortar mixes. Use only pigments with a record of satisfactory performance in masonry mortar.
 - I. Water: Potable.
- 2.03 REINFORCING STEEL
- A. Comply with reinforcing requirements in Section 03 31 00, Cast-in-Place Concrete.
 - B. Uncoated Steel Reinforcing Bars: ASTM A 615/A 615M; Grade 60.
 - C. Epoxy-Coated Reinforcing Steel: ASTM A 615/A 615M, Grade 60; epoxy coated to comply with ASTM A 775/A 775M.
- 2.04 MASONRY JOINT REINFORCEMENT
- A. General: ASTM A 951 and as follows:
 - 1. Hot-dip galvanized, carbon-steel wire.
 - 2. Wire Size for Side Rods: W2.8 or 0.188-inch diameter.
 - 3. Wire Size for Cross Rods: W2.8 or 0.188-inch diameter.
 - 4. Provide in lengths of not less than 10 feet, with prefabricated corner and tee units where indicated.
 - B. For single-wythe masonry, provide either ladder or truss type with single pair of side rods and cross rods spaced not more than 16 inches o.c.
- 2.05 TIES AND ANCHORS, GENERAL
- A. General: Provide ties and anchors made from materials that comply with this Article, unless otherwise indicated.
 - B. Hot-Dip Galvanized Carbon-Steel Wire: ASTM A 82; with ASTM A 153, Class B-2 coating.
 - C. Steel Sheet, Galvanized after Fabrication: ASTM A 366/A 366M cold-rolled, carbon-steel sheet hot-dip galvanized after fabrication to comply with ASTM A 153.
 - D. Steel Plates, Shapes, and Bars: ASTM A 36/A 36M.
- 2.06 MISCELLANEOUS ANCHORS
- A. Anchor Bolts: Steel bolts complying with ASTM A 307, Grade A; with ASTM A 563 hex nuts and, where indicated, flat washers; hot-dip galvanized to comply with ASTM A 153, Class C; of diameter and length indicated and in the following configurations:
 - 1. Headed bolts.
 - 2. Nonheaded bolts, bent in manner indicated.
 - B. Postinstalled Anchors: Anchors as described below, with capability to sustain, without failure, load imposed within factors of safety indicated, as determined by testing per ASTM E 488, conducted by a qualified independent testing agency.
 - 1. Type: Chemical anchors.
 - 2. Type: Expansion anchors only as noted on drawings.
 - 3. For Post installed Anchors in Concrete: Capability to sustain, without failure, a load equal to four times the loads imposed.

2.07 MISCELLANEOUS MASONRY ACCESSORIES

- A. Compressible Filler: Premolded filler strips complying with ASTM D 1056, Grade 2A1; compressible up to 35 percent; of width and thickness indicated; formulated from PVC.
- B. Preformed Control-Joint Gaskets: Material as indicated below, designed to fit standard sash block and to maintain lateral stability in masonry wall; size and configuration as indicated.
- C. Bond-Breaker Strips: Asphalt-saturated, organic roofing felt complying with ASTM D 226, Type I (No. 15 asphalt felt).
- D. Reinforcing Bar Positioners: Wire units designed to fit into mortar bed joints spanning masonry unit cells with loops for holding reinforcing bars in center of cells. Units are formed from 0.142-inch steel wire, hot-dip galvanized after fabrication.

2.08 MASONRY CLEANERS

- A. Job-Mixed Detergent Solution: Solution of 1/2-cup dry measure tetrasodium polyphosphate and 1/2-cup dry measure laundry detergent dissolved in 1 gal. of water.
- B. Proprietary Acidic Cleaner: Manufacturer's standard-strength cleaner designed for removing mortar/grout stains, efflorescence, and other new construction stains from new masonry without discoloring or damaging masonry surfaces. Use product expressly approved for intended use by cleaner manufacturer and manufacturer of masonry units being cleaned.

2.09 MORTAR AND GROUT MIXES

- A. General: Do not use admixtures, including pigments, air-entraining agents, accelerators, retarders, water-repellent agents, antifreeze compounds, or other admixtures, unless otherwise indicated.
- B. Preblended, Dry Mortar Mix: Furnish dry mortar ingredients in the form of a preblended mix. Measure quantities by weight to ensure accurate proportions, and thoroughly blend ingredients before delivering to Project site.
- C. Mortar for Unit Masonry: Comply with ASTM C 270, Property Specification.
 - 1. For masonry below grade, in contact with earth, and where indicated, use Type M.
 - 2. For reinforced masonry and where indicated, use Type S.
- D. Grout for Unit Masonry: Comply with ASTM C 476.
 - 1. Use grout of type indicated or, if not otherwise indicated, of type (fine or coarse) that will comply with Table 5 of ACI 530.1/ASCE 6/TMS 602 for dimensions of grout spaces and pour height.
 - 2. Provide grout with a slump of 8 to 10 inches as measured according to ASTM C 143.

2.10 SOURCE QUALITY CONTROL

- A. Concrete Masonry Unit Tests: For each type of concrete masonry unit indicated, units will be tested according to ASTM C 140.

PART 3 - EXECUTION

3.01 EXAMINATION

- A. Examine conditions, with Installer present, for compliance with requirements for installation tolerances and other conditions affecting performance.
 - 1. For the record, prepare written report, endorsed by Installer, listing conditions detrimental to performance.
 - 2. Verify that reinforcing dowels are properly placed.
 - 3. Proceed with installation only after unsatisfactory conditions have been corrected.
- B. Before installation, examine rough-in and built-in construction to verify actual locations of piping connections.

3.02 INSTALLATION, GENERAL

- A. Build single-wythe walls to the actual widths of masonry units, using units of widths indicated.
- B. Build chases and recesses to accommodate items specified in this Section and in other Sections of the Specifications.
- C. Leave openings for equipment to be installed before completing masonry. After installing equipment, complete masonry to match the construction immediately adjacent to the opening.
- D. Cut masonry units with motor-driven saws to provide clean, sharp, unchipped edges. Cut units as required to provide a continuous pattern and to fit adjoining construction. Where possible, use full-size units without cutting. Allow units cut with water-cooled saws to dry before placing, unless wetting of units is specified. Install cut units with cut surfaces and, where possible, cut edges concealed.

3.03 CONSTRUCTION TOLERANCES

- A. Comply with tolerances in ACI 530.1/ASCE 6/TMS 602 and the following:
- B. For conspicuous vertical lines, such as external corners, door jambs, reveals, and expansion and control joints, do not vary from plumb by more than 1/4 inch in 20 feet, nor 1/2 inch maximum.
- C. For vertical alignment of exposed head joints, do not vary from plumb by more than 1/4 inch in 10 feet, nor 1/2 inch maximum.
- D. For conspicuous horizontal lines, such as exposed lintels, sills, parapets, and reveals, do not vary from level by more than 1/4 inch in 20 feet, nor 1/2 inch maximum.
- E. For exposed head joints, do not vary from thickness indicated by more than plus or minus 1/8 inch. Do not vary from adjacent bed-joint and head-joint thicknesses by more than 1/8 inch.

3.04 LAYING MASONRY WALLS

- A. Lay out walls in advance for accurate spacing of surface bond patterns with uniform joint thicknesses and for accurate location of openings, movement-type joints, returns, and offsets. Avoid using less-than-half-size units, particularly at corners, jambs, and, where possible, at other locations.
- B. Bond Pattern for Exposed Masonry: Lay exposed masonry in a running bond pattern unless noted otherwise. Do not use units with less than nominal 4-inch horizontal face dimensions at corners or jambs.
- C. Stopping and Resuming Work: In each course, rack back one-half-unit length for one-half running bond or one-third-unit length for one-third running bond; do not tooth. Clean exposed surfaces of set masonry, wet clay masonry units lightly if required, and remove loose masonry units and mortar before laying fresh masonry.
- D. Built-in Work: As construction progresses, build in items specified under this and other Sections of the Specifications. Fill in solidly with masonry around built-in items.
- E. Fill space between hollow-metal frames and masonry solidly with mortar, unless otherwise indicated.
- F. Where built-in items are to be embedded in cores of hollow masonry units, place a layer of metal lath in the joint below and rod mortar or grout into core.
- G. Fill cores in hollow concrete masonry units with grout 24 inches under anchor bolt locations unless otherwise indicated.
- H. All door frames in new masonry walls are to be filled with mortar as they are laid-up. Also, the CMU hollow core nearest the new door frame is to be filled solid with grout full height of masonry opening. Coordinate with door frame's wall anchors.

3.05 MORTAR BEDDING AND JOINTING

- A. Lay hollow masonry units as follows:
 - 1. With full mortar coverage on horizontal and vertical face shells.
 - 2. Bed webs in mortar.
 - 3. For starting course on footings where cells are not grouted, spread out full mortar bed, including areas under cells.

3.06 CAVITIES

- A. Keep cavities clean of mortar droppings, debris, and other materials during construction. Strike joints facing cavities flush.
 - 1. Use wood strips temporarily placed in cavity to collect mortar droppings. As work progresses, remove strips, clean off mortar droppings, and replace in cavity.

3.07 MASONRY JOINT REINFORCEMENT

- A. General: Provide continuous masonry joint reinforcement as indicated. Install entire length of longitudinal side rods in mortar with a minimum cover of 5/8 inch on exterior side of walls, 1/2 inch elsewhere. Lap reinforcement a minimum of 6 inches. Space reinforcing a maximum of 16" on center.
- B. Cut or interrupt joint reinforcement at control and expansion joints, unless otherwise indicated.
- C. Provide continuity at corners and wall intersections by using prefabricated "L" and "T" sections. Cut and bend reinforcing units as directed by manufacturer for continuity at returns, offsets, column fireproofing, pipe enclosures, and other special conditions.

3.08 ANCHORING MASONRY TO STRUCTURAL MEMBERS

- A. Anchor masonry to structural members where masonry abuts or faces structural members to comply with the following:
 - 1. Provide an open space not less than 1 inch in width between masonry and structural member, unless otherwise indicated. Keep open space free of mortar or other rigid materials.
 - 2. Anchor masonry to structural members with flexible anchors embedded in masonry joints and attached to structure.
 - 3. Space anchors as indicated, but not more than 16 inches o.c.

3.09 CONTROL AND EXPANSION JOINTS

- A. General: Install control and expansion joints in unit masonry where indicated or a maximum of 25 feet on center. Build-in related items as masonry progresses. Do not form a continuous span through movement joints unless provisions are made to prevent in-plane restraint of wall or partition movement.
- B. Form control joints in concrete masonry as follows:
 - 1. Fit bond-breaker strips into hollow contour in ends of concrete masonry units on one side of control joint. Fill resultant core with grout and rake joints in exposed faces.
 - 2. Install preformed control-joint gaskets designed to fit standard sash block.
 - 3. Install interlocking units designed for control joints. Install bond-breaker strips at joint. Keep head joints free and clear of mortar or rake joint.

3.10 LINTELS

- A. Install steel lintels where indicated or as required for masonry openings shown on drawings. Lintel sizes to be sufficient to support weight of masonry and deflection requirements.
- B. Provide masonry lintels where shown and where openings of more than 12 inches for brick-size units and 24 inches for block-size units are shown without structural steel or other supporting lintels.
 - 1. Provide prefabricated or built-in-place masonry lintels. Use specially formed bond beam units with reinforcing bars placed as indicated and filled with coarse grout. Cure precast lintels before handling and installing. Temporarily support built-in-place lintels until cured.
- C. Provide minimum bearing of 8 inches at each jamb, unless otherwise indicated.

3.11 REINFORCED UNIT MASONRY INSTALLATION

- A. Temporary Formwork and Shores: Construct formwork and shores to support reinforced masonry elements during construction.

1. Construct formwork to conform to shape, line, and dimensions shown. Make it sufficiently tight to prevent leakage of mortar and grout. Brace, tie, and support forms to maintain position and shape during construction and curing of reinforced masonry.
 2. Do not remove forms and shores until reinforced masonry members have hardened sufficiently to carry their own weight and other temporary loads that may be placed on them during construction.
 - B. Placing Reinforcement: Comply with requirements of ACI 530.1/ASCE 6/TMS 602.
 - C. Grouting: Do not place grout until entire height of masonry to be grouted has attained sufficient strength to resist grout pressure.
 1. Comply with requirements of ACI 530.1/ASCE 6/TMS 602 for cleanouts and for grout placement, including minimum grout space and maximum pour height.
- 3.12 FIELD QUALITY CONTROL
- A. Testing Frequency: Tests and Evaluations listed in this Article will be performed during construction for each 5000 sq. ft. of wall area or portion thereof.
 - B. Mortar properties will be tested per ASTM C 780.
 - C. Grout will be sampled and tested for compressive strength per ASTM C 1019.
 - D. Concrete Masonry Unit Tests: For each type of concrete masonry unit indicated, units will be tested according to ASTM C 140.
 - E. Prism-Test Method: For each type of wall construction indicated, masonry prisms will be tested per ASTM C 1314, and as follows:
 1. Two prisms for each type of masonry.
- 3.13 REPAIRING, POINTING, AND CLEANING
- A. In-Progress Cleaning: Clean unit masonry as work progresses by dry brushing to remove mortar fins and smears before tooling joints.
 - B. Final Cleaning: After mortar is thoroughly set and cured, clean exposed masonry as follows:
 1. Remove large mortar particles by hand with wooden paddles and nonmetallic scrape hoes or chisels.
 2. Test cleaning methods on sample wall panel; leave one-half of panel uncleaned for comparison purposes. Obtain Architect's approval of sample cleaning before proceeding with cleaning of masonry.
 3. Protect adjacent stone and nonmasonry surfaces from contact with cleaner by covering them with liquid strippable masking agent, polyethylene film, or waterproof masking tape.
 4. Wet wall surfaces with water before applying cleaners; remove cleaners promptly by rinsing the surfaces thoroughly with clear water.
 5. Clean masonry with a proprietary acidic cleaner applied according to manufacturer's written instructions.
- 3.14 MASONRY WASTE DISPOSAL
- A. Recycling: Unless otherwise indicated, excess masonry materials are Contractor's property. At completion of unit masonry work, remove from Project site.
 - B. Excess Masonry Waste: Remove excess, clean masonry waste that cannot be used as fill, as described above, and other masonry waste, and legally dispose of off Owner's property.

END OF SECTION

THIS PAGE INTENTIONALLY LEFT BLANK

SECTION 04 73 13

NATURAL THIN VENEER STONE

PART 1 GENERAL

1.1 SECTION INCLUDES

- A. Natural thin veneer stone for exterior vertical surfaces.

1.2 RELATED SECTIONS

- A. Section 07 92 13 – Joint Sealant: Sealant and joint filler for perimeter and control joints.

1.3 REFERENCES

- A. ACI 530.1/ASCE 6/TMS 602 – Specifications for Masonry Structures.
- B. ANSI A118.4 – Specifications for Latex-Portland Cement Mortar.
- C. ASTM C 144 – Standard Specification for Aggregate for Masonry Mortar.
- D. ASTM C 207 – Standard Specification for Hydrated Lime for Masonry Purposes.
- E. ASTM C 270 – Standard Specification for Mortar for Unit Masonry.
- F. ASTM C 615 – Standard Specification for Granite Dimension Stone.
- G. ASTM C 847 – Standard Specification for Metal Lath.
- H. ASTM C 979 – Standard Specification for Pigments for Integrally Colored Concrete.
- I. ASTM C 1063 – Standard Specification for Installation of Lathing and Furring to Receive Interior and Exterior Portland Cement-Based Plaster.
- J. ASTM D 226 – Standard Specification for Asphalt-Saturated Organic Felt Used in Roofing and Waterproofing.
- K. PCA – Portland Cement Plaster (Stucco) Manual.

1.4 SUBMITTALS

- A. Submit under provisions of section 01 33 00.
- B. Product Data: Submit manufacturer's product data on stone, mortar products, and sealant products, including:
 - 1. Surface preparation and installation instructions.
 - 2. Storage and handling instructions.

- C. Shop Drawings: Submit manufacturer's shop drawings, including plans, elevations, sections, and details, indicating layout, dimensions, anchorages, and jointing methods.
- D. Selection Samples: Submit mortar color samples.
- E. Verification Samples: Submit 2 manufacturer's full-size samples of natural thin veneer stone for each pattern specified.
- F. Warranty: Submit manufacturer's standard warranty for natural thin veneer stone.

1.5 QUALITY ASSURANCE

- A. Manufacturer's Qualifications: Manufacturer regularly engaged, for preceding 10 years, in manufacture of natural thin veneer stone of similar type to that specified.
- B. Installer: Company specializing in installing the products specified in this section with minimum of three years documented experience and approved by the manufacturer.
- C. Mock-Ups: Provide a mock-up for evaluation of surface preparation techniques and application workmanship.
 - 1. Finish areas designated by Architect.
 - 2. Do not proceed with remaining work until workmanship, color, and sheen are approved by Architect.
 - 3. Refinish mock-up area as required to produce acceptable work.

1.6 DELIVERY, STORAGE, AND HANDLING

- A. Delivery: Deliver materials to site in manufacturer's original, unopened containers and packaging, with labels clearly identifying product name and manufacturer.
- B. Storage:
 - 1. Store materials in accordance with manufacturer's instructions.
 - 2. Store materials in manufacturer's unopened packaging until ready for installation.
 - 3. Store stone materials on pallets on dry, level surface and cover with tarps.
 - 4. Do not stack pallets.
 - 5. Mortar: Store mortar under cover in area where air temperature is maintained between 40 degrees F and 110 degrees F.
- C. Handling: Protect materials during handling and installation to prevent damage or contamination.

1.7 PROJECT ENVIRONMENTAL REQUIREMENTS

- A. Maintain environmental conditions (temperature, humidity, and ventilation) within limits recommended by manufacturer for optimum results. Do not install natural thin veneer stone under environmental conditions outside manufacturer's limits.
- B. Hot and Cold Weather Requirements: ACI 530.1/ASCE 6/TMS 602.
- C. Air Temperature: 40 degrees F or above during installation of natural thin veneer stone.
- D. Mortar Mixing Water: Heat mortar mixing water when air temperature falls below 50 degrees F.

1.8 WARRANTY

- A. Provide one year warranty under the provisions of Section 01 78 00.

PART 2 PRODUCTS

2.1 MANUFACTURER

- A. Vermont Thinstone, 780 Quarry Road, Sharon, VT 05065
Phone (802) 522-2453 Website www.vermonththinstone.com
- B. Substitutions: Under provisions of Section 01 60 00.

2.2 NATURAL THIN VENEER STONE

- A. Baltic Blue granite.
1. Pattern: LedgeStone.
 - a. Height: 1 inch to 4 inches.
 - b. Length: 4 inches to 16 inches.
 - c. Nominal Thickness: 1 inch to 1-1/4 inches.
 - d. Color: Blue-green-grey tones.
 - e. Material: granite schist

2.3 SPECIAL SHAPES

- A. Provide special shapes as indicated on the Drawings and as follows:
1. Baltic Blue granite cap
 2. The sill of the veneer is to be the veneer with no special shapes.

2.4 ACCESSORIES

- A. Expanded Metal Lath: ASTM C 847; galvanized, self-furring.
- B. Lath Anchorage: Tie wire, nails, screws, and other metal supports; galvanized; type and size to suit application and to rigidly secure materials in place.
- C. Concrete Bonding Agent: Latex type.
- D. Setting Buttons and Shims: Lead or plastic.
- E. Joint Sealants and Joint Fillers: As specified in Section 07 92 13.

2.5 MORTAR

- A. Mortar:
1. Cement: ASTM C 270.
 2. Lime: ASTM C 207.
 3. Sand: ASTM C 144, natural or manufactured.
 4. Color Pigments: ASTM C 979, mineral oxide.

5. Water: Potable.
 6. Pre-Packaged Latex-Portland Cement Mortar: ANSI A118.4.
- B. Bonding Agent: Acrylic additive.
- C. Sealer: Water-based silane or siloxane masonry sealer, clear.
- D. Mortar Mixes:
1. Jointless Dry-Stack Installation:
 - a. Mix mortar in accordance with ANSI A118.4.
 - b. Add color pigments in accordance with pigment manufacturer's instructions.

PART 3 EXECUTION

3.1 EXAMINATION

- A. Install thin veneer stone in accordance to manufacturer's instructions.
- B. Examine surfaces to receive natural thin veneer stone.
- C. Notify Architect of conditions that would adversely affect installation.
- D. Do not begin surface preparation or installation until unacceptable conditions are corrected.
- E. Do not begin installation until backing structure is plumb, bearing surfaces are level, and substrates are clean and properly prepared.
- F. Verify location and secure installation if shelf angles are required.

3.2 SURFACE PREPARATION

- A. Prepare surfaces in accordance with manufacturer's instructions.
- B. Clean surfaces thoroughly before installation.
- C. Prepare surfaces using methods for achieving best results for substrate under project conditions.
- D. Prepare for Installation Over masonry surface:
 1. Metal Lath:
 - a. Install metal lath in accordance with ASTM C 1063.
 - b. Apply metal lath with long dimension perpendicular to supports and with joints lapped a minimum of 1 inch.
 - c. Secure laps with tie wire where they occur between supports.
 2. Fastening Metal Lath:
 - a. Attach lath to concrete using galvanized concrete nails at maximum 6 inches on center vertically and 16 inches on center horizontally.
 - b. Stop lath 1 inch from finished edges.
- E. Application of Base Coat Stucco:
 1. Apply scratch coat in accordance with PCA Plaster (Stucco) Manual.

2. Apply scratch coat to nominal thickness of 1/2 inch to 3/4 inch over metal lath surfaces.
3. If weather is hot or surface is dry, dampen previous coat before applying mortar and thin stone veneer.
4. If scratch coat is done in advance, use notch trowel to create texture for better bond. Smooth surface is not acceptable for bond.

F. Prepare for Installation of Thin Veneer Stone:

1. Coordination: Coordinate placement of reinforcement, anchors, accessories, flashings, weep holes, and other moisture-control products specified in other sections.
2. Cleaning: Clean built-in items of loose rust, ice, mud, and other foreign matter before incorporating into wall.
3. Prime or galvanize ferrous metal built into wall.
4. Temporary Bracing:
 - a. Provide temporary bracing as required during installation of masonry.
 - b. Maintain bracing in place until building structure provides permanent support.

3.4 DRY-STACK INSTALLATION

- A. Install thin veneer stone and mortar in accordance with manufacturer's instructions and ACI 530.1/ASCE 6/TMS 602.
- B. Maintain masonry courses to uniform dimensions. Form vertical and horizontal joints of uniform thickness.
- C. Pattern Bond:
 1. Lay out work in advance and distribute color range of stone uniformly over total work area.
 2. Lay stone with face exposed.
 3. Take care to avoid a concentration of any one color to any one wall surface.
 4. Maintain squared and uniform profile.
 5. Do not use stacked vertical joints.
- D. Placing and Bonding:
 1. Dampen substrate as required to reduce excessive suction.
 2. Use thin-set mortar in accordance with ANSI A118.4 for exterior dry stack installation.
 3. Apply mortar to thickness of 1/4 inch to back of stone.
 4. Press firmly to seat each stone as placed.
 5. Work from bottom up, laying corner pieces first.
 6. Remove excessive mortar as work progresses.
 7. Do not shift or tap veneer stone after mortar has achieved initial set. Where adjustment is required, remove mortar and replace.
 8. Isolate top of veneer stone from horizontal structural framing members and slabs or decks with compressible joint filler and sealant as specified in Section 07 92 13.
- E. Joints:
 1. Lay stone with reasonably uniform joints, as stone allows.
 2. Remove excess mortar as stone is pressed into position.
 3. Use non-corrosive stone shims as required to maintain joint thickness.
- F. Control and Expansion Joints:
 1. Keep joints open and free of debris.

2. Coordinate control joints as specified in Section 07 92 13 for sealant performance.

G. Sealant Recesses:

1. Provide open joints 3/4 inch deep and 1/4 inch wide, where masonry meets doors, windows, and other exterior openings.
2. Coordinate sealant joints as specified in Section 07 92 13 for sealant performance.

H. Cutting and Fitting:

1. Cut and fit thin veneer stone for chases, pipes, conduit, sleeves, grounds, and other penetrations and adjacent materials.
2. Coordinate with other work to provide correct size, shape, and location.

I. During the progress of the work, cover top of unfinished stone masonry work for protection from weather.

3.5 CLEANING

- A. Keep face of stone free of mortar as work progresses.
- B. If residual mortar is on face of stone, allow to dry partially and brush mortar off surface and sponge off residue.
- C. When work is completed and mortar has set for 2 to 3 days, clean surface from top to bottom using mild masonry detergent acceptable to natural thin veneer stone manufacturer.
- D. Do not use harsh cleaning materials or methods that could damage stone.
- E. Do not use metal brushes or acids for cleaning.

3.6 PROTECTION

- A. Protect installed natural thin veneer stone to ensure that, except for normal weathering, stone will be without damage or deterioration at time of Substantial Completion.
- B. Touch-up, repair, or replace damaged stone before Substantial Completion.

END OF SECTION

SECTION 05 12 00

STRUCTURAL STEEL

PART 1 - GENERAL

1.1 RELATED DOCUMENTS

- A. Drawings and general provisions of the Contract, including General and Supplementary Conditions and Division 1 Specification Sections, apply to this Section.

1.2 SUMMARY

- A. This Section includes the following:

- 1. Structural steel.
- 2. Grout.

- B. Related Sections include the following:

- 1. Division 1 Section "Quality Requirements" for independent testing agency procedures and administrative requirements.
- 2. Division 9 Painting and Coatings for surface preparation and priming requirements.

1.3 DEFINITIONS

- A. Structural Steel: Elements of structural-steel frame, as classified by AISC's "Code of Standard Practice for Steel Buildings and Bridges," that support design loads.

1.4 PERFORMANCE REQUIREMENTS

- A. Connections: Provide details of simple connections required by the Contract Documents to be selected or completed by structural-steel fabricator to withstand loads indicated and comply with other information and restrictions indicated.

- 1. Select and complete connections using AISC's "Steel Construction Manual, 14th Edition."

1.5 SUBMITTALS

- A. Product Data: For each type of product indicated.
- B. Shop Drawings: Show fabrication of structural-steel components.

1. Include details of cuts, connections, splices, holes, and other pertinent data.
2. Include embedment drawings.
3. Indicate welds by standard AWS symbols, distinguishing between shop and field welds, and show size, length, and type of each weld.
4. Indicate type, size, and length of bolts, distinguishing between shop and field bolts. Identify pre-tensioned and slip-critical high-strength bolted connections.
5. For structural-steel connections indicated to comply with design loads.

C. Welding certificates.

D. Qualification Data: For testing agency.

E. Mill Test Reports: Signed by manufacturers certifying that the following products comply with requirements:

1. Structural steel including chemical and physical properties.
2. Bolts, nuts, and washers including mechanical properties and chemical analysis.
3. Direct-tension indicators.
4. Tension-control, high-strength bolt-nut-washer assemblies.
5. Shear stud connectors.
6. Shop primers.
7. Non-shrink grout.

F. Source quality-control test reports.

1.6 QUALITY ASSURANCE

A. Welding: Qualify procedures and personnel according to AWS D1.1, "Structural Welding Code--Steel."

B. Comply with applicable provisions of the following specifications and documents:

1. AISC's "Code of Standard Practice for Steel Buildings and Bridges."
2. AISC's "Seismic Provisions for Structural Steel Buildings" and "Supplement No. 2."
3. AISC's "Specification for Structural Steel Buildings, 14th Edition.
4. AISC's "Specification for the Design of Steel Hollow Structural Sections."
5. RCSC's "Specification for Structural Joints Using High Strength Bolts."

1.7 DELIVERY, STORAGE, AND HANDLING

A. Store materials to permit easy access for inspection and identification. Keep steel members off ground and spaced by using pallets, dunnage, or other supports and spacers. Protect steel members and packaged materials from erosion and deterioration.

1. Store fasteners in a protected place. Clean and re-lubricate bolts and nuts that become dry or rusty before use.
2. Do not store materials on structure in a manner that might cause distortion, damage, or overload to members or supporting structures. Repair or replace damaged materials or structures as directed.

1.8 COORDINATION

- A. Furnish anchorage items to be embedded in or attached to other construction without delaying the Work. Provide setting diagrams, sheet metal templates, instructions, and directions for installation.

PART 2 - PRODUCTS

2.1 STRUCTURAL-STEEL MATERIALS

- A. Wide Flange Section Structural Beams (W): ASTM A992
- B. Channel, Plate, Angles, and Bar: ASTM A 36.
- C. Cold-Formed Hollow Structural Sections: ASTM A 500, Grade C, structural tubing.
- D. Steel Pipe: ASTM A53, Grade B.
- E. Welding Electrodes: Comply with AWS requirements.

2.2 BOLTS, CONNECTORS, AND ANCHORS

- A. High-Strength Bolts, Nuts, and Washers: ASTM A 325 or ASTM F 1852, Type 1, heavy hex steel structural bolts; ASTM A 563 heavy hex carbon-steel nuts; and ASTM F 436 hardened carbon-steel washers.
 - a. Finish: Plain.
- B. Unheaded Anchor Rods: ASTM F 1554.
 - 1. Configuration: Straight and Hooked, as shown.
 - 2. Nuts: ASTM A 563 (ASTM A 563M) hex carbon steel.
 - 3. Plate Washers: ASTM A 36/A 36M carbon steel.
 - 4. Washers: ASTM F 436 hardened carbon steel.
 - 5. Finish: Plain.
- C. Headed Anchor Rods: ASTM F 1554.
 - 1. Nuts: ASTM A 563 hex carbon steel.
 - 2. Plate Washers: ASTM A 36/A 36M carbon steel.
 - 3. Washers: ASTM F 436 (ASTM F 436M) hardened carbon steel.
 - 4. Finish: Plain.
- D. Threaded Rods: ASTM F 1554.
 - 1. Nuts: ASTM A 563 hex carbon steel.
 - 2. Washers: ASTM F 436 hardened carbon steel.
 - 3. Finish: Plain.

2.3 PRIMER

- A. Primer: Fabricator's standard lead- and chromate-free, non-asphaltic, rust-inhibiting primer.

2.4 GROUT

- A. Nonmetallic, Shrinkage-Resistant Grout: ASTM C 1107, factory-packaged, nonmetallic aggregate grout, noncorrosive, non-staining, mixed with water to consistency suitable for application and a 30-minute working time.

2.5 FABRICATION

- A. Structural Steel: Fabricate and assemble in shop to greatest extent possible. Fabricate according to AISC's "Code of Standard Practice for Steel Buildings and Bridges" and AISC's "Specification for Structural Steel Buildings."
 - 1. Mark and match-mark materials for field assembly.
 - 2. Complete structural-steel assemblies, including welding of units, before starting shop-priming operations.
- B. Thermal Cutting: Perform thermal cutting by machine to greatest extent possible.
 - 1. Plane thermally cut edges to be welded to comply with requirements in AWS D1.1.
- C. Bolt Holes: Cut, drill, or punch standard bolt holes perpendicular to metal surfaces.
- D. Finishing: Accurately finish ends of columns and other members transmitting bearing loads.
- E. Cleaning: Clean and prepare steel surfaces according to SSPC-SP 3, "Power Tool Cleaning."

2.6 SHOP CONNECTIONS

- A. Weld Connections: Comply with AWS D1.1 for welding procedure specifications, tolerances, appearance, and quality of welds and for methods used in correcting welding work.
 - 1. Remove backing bars or runoff tabs, back gouge, and grind steel smooth.
 - 2. Assemble and weld built-up sections by methods that will maintain true alignment of axes without exceeding tolerances of AISC's "Code of Standard Practice for Steel Buildings and Bridges" for mill material.

2.7 SHOP PRIMING

- A. Shop prime steel surfaces.

- B. Surface Preparation: Clean surfaces to be painted. Remove loose rust and mill scale and spatter, slag, or flux deposits. Prepare surfaces according to the following specifications and standards:
 - 1. SSPC-SP 3, "Power Tool Cleaning."
- C. Priming: Immediately after surface preparation, apply primer according to manufacturer's written instructions and at rate recommended by SSPC to provide a dry film thickness of not less than 1.5 mils (0.038 mm). Use priming methods that result in full coverage of joints, corners, edges, and exposed surfaces.
 - 1. Stripe paint corners, crevices, bolts, welds, and sharp edges.
 - 2. Apply two coats of shop paint to inaccessible surfaces after assembly or erection. Change color of second coat to distinguish it from first.
- D. Painting: Apply a 1-coat, non-asphaltic primer complying with SSPC-PS Guide 7.00, "Painting System Guide 7.00: Guide for Selecting One-Coat Shop Painting Systems," to provide a dry film thickness of not less than 1.5 mils (0.038 mm).

2.8 GALVANIZING

- A. Hot-Dip Galvanized Finish: Apply zinc coating by the hot-dip process to structural steel according to ASTM A 123/ A 123M.
 - 1. Fill vent holes and grind smooth after galvanizing.
 - 2. Galvanize lintels and shelf angles.

2.9 SOURCE QUALITY CONTROL

- A. Owner will engage an independent testing and inspecting agency to perform shop tests and inspections and prepare test reports.
 - 1. Provide testing agency with access to places where structural-steel work is being fabricated or produced to perform tests and inspections.
- B. Correct deficiencies in Work that test reports and inspections indicate does not comply with the Contract Documents.
- C. Welded Connections: Shop-welded connections will be visually inspected.

PART 3 - EXECUTION

3.1 EXAMINATION

- A. Verify elevations of concrete-bearing surfaces and locations of anchor rods, bearing plates, and other embedments, with steel erector present, for compliance with requirements.
- B. Proceed with installation only after unsatisfactory conditions have been corrected.

3.2 PREPARATION

- A. Provide temporary shores, guys, braces, and other supports during erection to keep structural steel secure, plumb, and in alignment against temporary construction loads and loads equal in intensity to design loads. Remove temporary supports when permanent structural steel, connections, and bracing are in place, unless otherwise indicated.

3.3 ERECTION

- A. Set structural steel accurately in locations and to elevations indicated and according to AISC's "Code of Standard Practice for Steel Buildings and Bridges" and "Specification for Structural Steel Buildings."
- B. Base Plates: Clean concrete- and masonry-bearing surfaces of bond-reducing materials, and roughen surfaces prior to setting base plates. Clean bottom surface of base plates.
 - 1. Set base plates for structural members on wedges, shims, or setting nuts as required.
 - 2. Snug-tighten anchor rods after supported members have been positioned and plumbed. Do not remove wedges or shims but, if protruding, cut off flush with edge of base plate before packing with grout.
 - 3. Promptly pack grout solidly between bearing surfaces and base plates so no voids remain. Neatly finish exposed surfaces; protect grout and allow to cure. Comply with manufacturer's written installation instructions for shrinkage-resistant grouts.
- C. Maintain erection tolerances of structural steel within AISC's "Code of Standard Practice for Steel Buildings and Bridges."
- D. Align and adjust various members forming part of complete frame or structure before permanently fastening. Before assembly, clean bearing surfaces and other surfaces that will be in permanent contact with members. Perform necessary adjustments to compensate for discrepancies in elevations and alignment.
 - 1. Level and plumb individual members of structure.
- E. Do not use thermal cutting during erection unless approved by Architect.
- F. Do not enlarge unfair holes in members by burning or using drift pins. Ream holes that must be enlarged to admit bolts.

3.4 FIELD CONNECTIONS

- A. High-Strength Bolts: Install high-strength bolts according to RCSC's "Specification for Structural Joints Using High-Strength Bolts" for type of bolt and type of joint specified.
 - 1. Joint Type: Snug tightened.
- B. Weld Connections: Comply with AWS D1.1 for welding procedure specifications, tolerances, appearance, and quality of welds and for methods used in correcting welding work.

1. Comply with AISC's "Code of Standard Practice for Steel Buildings and Bridges" and "Specification for Structural Steel Buildings" for bearing, adequacy of temporary connections, alignment, and removal of paint on surfaces adjacent to field welds.
2. Remove backing bars or runoff tabs, back gouge, and grind steel smooth.
3. Assemble and weld built-up sections by methods that will maintain true alignment of axes without exceeding tolerances of AISC's "Code of Standard Practice for Steel Buildings and Bridges" for mill material.

3.5 FIELD QUALITY CONTROL

- A. Testing Agency: Owner will engage a qualified independent testing and inspecting agency to inspect field welds and high-strength bolted connections.
- B. Bolted Connections: Shop-bolted connections will be tested and inspected according to RCSC's "Specification for Structural Joints Using High-Strength Bolts."
- C. Welded Connections: Field welds will be visually inspected according to AWS D1.1.
- D. Correct deficiencies in Work that test reports and inspections indicate does not comply with the Contract Documents.

3.6 REPAIRS AND PROTECTION

- A. Touchup Painting: After installation, promptly clean, prepare, and prime or re-prime field connections, rust spots, and abraded surfaces of prime-painted joists and accessories, base plates, and abutting structural steel.
 1. Clean and prepare surfaces by SSPC-SP 3 power-tool cleaning.
 2. Apply a compatible primer of same type as shop primer used on adjacent surfaces.

END OF SECTION 05 12 00

THIS PAGE INTENTIONALLY LEFT BLANK

SECTION 05 31 00

STEEL DECK

PART 1 - GENERAL

1.1 SUMMARY

A. This Section includes the following:

1. Roof deck.

1.2 SUBMITTALS

A. Product Data: For each type of deck, accessory, and product indicated.

B. Shop Drawings: Include layout and types of deck panels, anchorage details, reinforcing channels, pans, deck openings, special jointing, accessories, and attachments to other construction.

C. Product certificates.

D. Welding certificates.

E. Research/Evaluation Reports: Evidence of steel deck's compliance with building code in effect for Project, from a model code organization acceptable to authorities having jurisdiction.

1.3 QUALITY ASSURANCE

A. Welding: Qualify procedures and personnel according to AWS D1.1, "Structural Welding Code--Steel," and AWS D1.3, "Structural Welding Code--Sheet Steel."

B. Testing Agency Qualifications: An independent testing agency, acceptable to authorities having jurisdiction, qualified according to ASTM E 329 to conduct the testing indicated, as documented according to ASTM E 548.

C. AISI Specifications: Calculate structural characteristics of steel deck according to AISI's "Specification for the Design of Cold-Formed Steel Structural Members."

PART 2 - PRODUCTS

2.1 ROOF DECK

- A. Steel Floor Deck: Fabricate panels, without top-flange stiffening grooves, to comply with "SDI Specifications and Commentary for Steel Roof Deck," in SDI Publication No. 29.
 - 1. Galvanizing: ASTM A 525; G90, 0.90 oz/sq. ft.
 - 2. Deck Profile: Type B, wide rib.
 - 3. Profile Depth: 1-1/2 inches.
 - 4. Design Uncoated-Steel Thickness: 0.0358 inch

2.2 ACCESSORIES

- A. Accessories: Steel deck manufacturer's standard accessory materials, including mechanical fasteners, closure strips, pour stops, and closures for deck.
- B. Galvanizing Repair Paint: High zinc-dust content paint for repair of damaged galvanized surfaces complying with Military Specifications MIL-P-21035 (Ships).

PART 3 - EXECUTION

3.1 INSTALLATION

- A. Install deck panels and accessories according to applicable specifications and commentary in SDI Publication No. 29, manufacturer's written instructions, and requirements in this Section.
- B. Place deck panels on supporting frame and adjust to final position with ends accurately aligned and bearing on supporting frame before being permanently fastened. Do not stretch or contract side-lap interlocks.
- C. Place deck panels flat and square and fasten to supporting frame without warp or deflection.
- D. Cut and neatly fit deck panels and accessories around openings and other work projecting through or adjacent to decking.
- E. Provide additional reinforcement and closure pieces at openings as required for strength, continuity of decking, and support of other work.
- F. Comply with AWS requirements and procedures for manual shielded metal arc welding, appearance and quality of welds, and methods used for correcting welding work.
 - 1. Mechanical fasteners may be used in lieu of welding to fasten deck. Locate mechanical fasteners and install according to deck manufacturer's written instructions.

G. Roof Deck Accessories: Install sump pans ridge and valley plates, finish strips, cover plates, end closures, and reinforcing channels according to deck manufacturer's written instructions. Weld to substrate to provide a complete deck installation. H. Repairs and Protection:

1. Repair Painting: Wire brush and clean rust spots, welds, and abraded areas on both surfaces of prime-painted deck immediately after installation, and apply repair paint.

3.2 FIELD QUALITY CONTROL

A. Testing: Owner will engage a qualified independent testing agency to perform field quality-control testing.

B. Field welds will be subject to inspection.

C. Shear connector stud welds will be tested and inspected according to AWS D1.1.

D. Remove and replace work that does not comply with specified requirements.

E. Additional testing and inspecting, at Contractor's expense, will be performed to determine compliance of corrected work with specified requirements.

3.3 REPAIRS AND PROTECTION

A. Repair Painting: Wire brush and clean rust spots, welds, and abraded areas on surfaces of prime-painted deck immediately after installation, and apply repair paint.

B. Provide final protection and maintain conditions to ensure that steel deck is without damage or deterioration at time of Substantial Completion.

END OF SECTION 05 31 00

THIS PAGE INTENTIONALLY LEFT BLANK

SECTION 05 50 00

MISCELLANEOUS METAL WORK

PART 1 - GENERAL

1.01 SUMMARY

- A. Related Documents:
The Drawings and general provisions of the Contract, including General and Supplementary General Conditions, and Division 1 Requirements, apply to the work in this Section.

1.02 SECTION INCLUDES

- A. Miscellaneous metal work items as described in this Specification Section.
- B. Section includes, without limitation, providing and installing:
1. Shop applied ferrous metals priming paint for miscellaneous metals.
 2. Anchorages, brackets, supports, inserts and backing required for a complete job but not included in other sections.
 3. All other ferrous or non-ferrous metal work not specifically given to other Sections and necessary for a complete job, but including:
 - a. Galvanized steel framing, lintels and supports for overhead doors. (Structural HSS tube, structural steel bent plate door jambs.
 - b. Galvanized steel framing and supports for mechanical and electrical equipment.
- C. Items To Be Furnished Only: Furnish the following items for installation by the designated Sections
1. Section 03 30 00 - Cast-in-place Concrete:
 - a. Sleeves, anchors, inserts, plates and similar items.
 - b. Galvanized steel slab edge angle at overhead door sills.
 2. Section 04 22 23 – Masonry:
Miscellaneous metal and iron sleeves, anchors, inserts, plates and lintels to be built into masonry walls, including:
 - a. Furnishing loose bearing plates with headed anchors to support steel beams and metal deck on masonry.
 - b. Loose steel bearing and leveling plates, including bearing plates for steel joists, beams and purlins, galvanized at exterior locations and in exterior walls.
 - c. Epoxy anchors to fasten seismic clips to masonry.
 - d. Anchor bolts to fasten spandrel beams to masonry.
 - e. Galvanized steel lintels at exterior locations.
 - f. Steel lintels with shop applied zinc-rich primer at interior locations.

3. Miscellaneous items
 - a. Miscellaneous steel trim, galvanized at exterior locations.
 - b. All plates, threaded rods and angles required to support suspended HVAC units from building structure.

1.03 RELATED SECTIONS

- A. Section 04 22 24 - Concrete Unit Masonry-Interior
- B. Section 09 90 10 – Painting

1.03 SUBMITTALS

- A. Submit shop drawings, product data under provisions of Section 01 33 00. Include plans, elevations, sections, details, and attachments to other work. Show anchorage and accessory items.
- B. Submit samples of product as requested by the architect. Submit 8" square samples of each metal shop or factory finish (final surface treatment) required. Prepare samples on metal of same alloy and gauge to be used for the work. Label each sample to identify substrate material and finish. Provide hardware samples.
- C. Manufacturer's Data: Submit manufacturer's specifications, anchor details and installation instructions for any prefabricated products to be used in the work of this section

1.04 REGULATORY REQUIREMENTS

- A. Conform to all federal, state, and local codes.

1.05 QUALITY ASSURANCE

- A. Welding Qualifications: Qualify procedures and personnel according to AWS D1.1/D1.1M, "Structural Welding Code - Steel."
- B. Engineering Calculations: Calculations stamped by a registered professional engineer are required for load bearing fabrications. The Structural Engineer's written approval of such calculations shall be obtained before commencing fabrication

1.06 DELIVERY, STORAGE, AND HANDLING

- A. Deliver, store, protect and handle products to site under provisions of Section 01 60 00.

1.07 FIELD MEASUREMENTS

- A. Verify actual locations of walls and other construction contiguous with metal fabrications by field measurements before fabrication.

PART 2 - PRODUCTS

2.01 GENERAL FABRICATION REQUIREMENTS

- A. Welding shall conform to the applicable requirements of the American Welding Society. Welding shall be done in a manner that will prevent permanent buckling and all welds exposed in the finished work shall be ground to an architectural quality smooth appearance approved by the Architect.
- B. Exposed surfaces shall have a smooth finish and sharp, well defined lines. Sections shall be formed to shape and size with sharp lines and angles. Curved work shall be sprung evenly.
- C. Necessary rabbets, lugs and brackets shall be provided so that work can be assembled and anchored in a neat and substantial manner. Holes for bolts and screws shall be drilled. Fastenings shall be concealed where practicable.
- D. Work shall be fabricated and installed in a manner that will provide for expansion and contraction, prevent the shearing of bolts, screws and other fastenings, insure rigidity and provide close fitting of sections. Joints exposed to the weather shall be formed to exclude water.
- E. All galvanized metal shall bear a stamp indicating ASTM number and weight of zinc coating in ounces per square foot.

2.02 MATERIALS

- A. Materials shall conform to the latest edition of the specifications or manufacturer's standards.
 - 1. Steel Shapes ASTM A-36 Bars & Plates
 - 2. Anchor Bolts ASTM A-307 Grade A
 - 3. Structural Bolts ASTM A-325 (unless shown or indicated otherwise)
 - 4. Weld Material E70XX Welding Electrodes For manual shielded metal-arc welding, AWS A5.1 or A5.5, E60 or E70 series
 - 5. Galvanizing ASTM A-123, , or A-153 as applicable; 2.0 ounces zinc per square foot, unless otherwise indicated; provide under its section.
 - 6. Stainless Steel Type 304L, ASTM A 276
 - 7. Steel bar gratings ASTM A-569 or A-36
 - 8. Bitumastic Preservative Mil-P-15230 [Where shown and all embedded steel]
 - 9. Galvanized Sheet Steel ASTM A-526 or A-526, G-90
 - 10. Hot-Rolled Carbon Steel Bars (and Bar-Size Shapes): ASTM A-36 or A-529, grade as selected by fabricator.
 - 11. Brackets, flanges and exposed fastenings: Shall be of the same materials, color and finish as the metal to which they are applied, unless shown or specified otherwise.
 - 12. Expansion bolts at concrete: Red Head (or equal) wedge anchors.
 - 13. Expansion bolts at CMU: Hilti (or equal) epoxy/masonry anchors
- B. Hangers and suspension: Where required, provide Uni-strut (or equal) A1000 or assemblies of types recommended by manufacturer for application.
- C. Galvanizing Repair Paint: High zinc dust content paint, ZRC (or equal), having 95% zinc. by weight. Two coats always are required.

2.03 SHOP PAINTING

- A. All surfaces of ferrous metal except galvanized steel shall be given a shop coat of red lead, zinc-chromate paint or other approved rust-inhibitive primer unless otherwise specified. All surfaces which will be inaccessible for painting after erection, except contact surfaces of riveted or welded connections, shall be given two coats of paint before being assembled or erected. All marred surfaces of shop coats shall be thoroughly recoated. Field painting is specified under Section 09 91 00.

2.04 ANCHORING CEMENT:

- A. Anchoring non-shrink grout shall be Hallemite "Por-rok" or equal.

2.05 CLEANING:

- A. Clean under provisions of Section 01 70 00.
- B. The Contractor shall clean the miscellaneous metal work by removing all excess sealants, dirt and foreign materials, restoring finishes, leaving work in a good and satisfactory condition. The Contractor shall perform the work of cleaning using methods and materials as recommended by the manufacturers of the materials used and as approved.

PART 3 - EXECUTION

3.01 INSPECTION

- A. Review existing field conditions of areas to receive the work of this Section before proceeding with fabrication. Do not proceed with installation of metal fabrications until all unsatisfactory conditions which would impair the strength or appearance of the work have been corrected.

3.02 INSTALLATION OF METAL FABRICATIONS

- A. Fastening to In-Place Construction: Provide anchorage devices and fasteners and furnish all necessary setting drawings, diagrams, and templates where necessary for securing miscellaneous metal items to in-place construction including threaded fasteners for concrete and masonry inserts, toggle bolts, through-bolts, lag bolts, wood screws and other connectors as required. Use galvanized bolts at exterior. Coordinate delivery of such items to project site.
- B. Cutting: Perform cutting, drilling and fitting required for installation of miscellaneous metal items. Do not cut structural members in field to facilitate fitting without written permission of the Architect for each specific condition.
- C. Fitting: Fit exposed connections accurately together to form tight hairline joints. Weld connections which are not to be left as exposed joints, but cannot be shop welded because of shipping size limitations. Grind joints smooth. Do not weld, cut or abrade the surfaces of exterior units which have been hot-dip galvanized after fabrication, and are intended for bolted or screwed field connections.
- D. Placement: Set work accurately in location, alignment and elevation, plumb, level, true and

free of rack, measured from established lines and levels. Provide temporary bracing or anchors in formwork for items which are to be built into concrete, masonry or similar construction.

- E. Field Welding: Comply with AWS Code for procedures of manual shielded metal-arc welding, appearance and quality of welds made, and methods used in correcting welding work. Do not field weld stainless steel or aluminum.
- F. Grouting: Set bearing plates required for support of the work of this Section level and to correct elevation using steel shims or wedges and grout solid using specified non-shrink grout.
- G. Touch-Up of Shop Primers: Touch up field welds and unprimed steel using specified shop primers and following procedures specified for shop work.

3.03 PRODUCTS

- A. Anchors and Bolts:
Anchors and bolts shall be provided where indicated and where necessary for fastening work in place. They shall be embedded in concrete and masonry as the work progresses. Sizes, kinds and spacing of anchors not indicated or specified shall be as necessary for their purpose.
- B. Steel:
Steel for the support of piping and appurtenances shall be provided to the details indicated and as necessary for the complete installation.
- C. Pipe Hangers and Miscellaneous Supports:
Pipe hangers and miscellaneous supports shall be provided as required.
- D. Miscellaneous Framing and Supports:
 - 1. Provide miscellaneous steel framing and supports which are not a part of structural steel framework, as required.
 - 2. Fabricate miscellaneous units to sizes, shapes and profiles shown or, if not shown, of required dimensions to receive work to be supported by framing. Except as otherwise shown, fabricate from structural steel shapes and plates and steel bars, of welded construction using mitered joints for field connection. Cut, drill and tap units to receive hardware and similar items.
 - 3. Equip units with integrally welded anchor straps for casting into poured concrete or building into masonry wherever required. Furnish concrete inserts if units must be installed after concrete is placed.
- E. Pipe Rails
 - 1. Pipe rails for stairs, ramps, platforms, and landings shall be constructed of standard galvanized steel pipe unless noted otherwise. For galvanized railings, provide hot-dip galvanized fittings, brackets, fasteners, sleeves, and other ferrous components.
 - 2. The railing design shall be as per drawings.
 - 3. Railing posts set in concrete shall be installed in pipe sleeves, securely anchored using non-shrink grout to minimum 4" depth. Inside dimensions of sleeve is to be not less than 1/2 inch greater than the outside dimensions of post with metal plate forming bottom closure.

4. Railings shall meet all state building, fire and accessibility code requirements for height, openings, end extensions, etc.
5. Rails attached to walls shall be anchored securely and all ends shall return to terminate against wall. Close ends of returns with prefabricated end fittings unless clearance between end of rail and wall is 1/4 inch or less.
6. Provide metal materials with smooth surfaces, without seam marks, roller marks, rolled trade names, stains, discolorations, or blemishes.
7. Brackets, Flanges, and Anchors: Cast or formed metal of same type of material and finish as supported rails unless otherwise indicated.
8. Fabrication
 - a. Assemble railings in the shop to greatest extent possible to minimize field splicing and assembly. Disassemble units only as necessary for shipping and handling limitations. Clearly mark units for reassembly and coordinated installation. Use connections that maintain structural value of joined pieces.
 - b. Cut, drill, and punch metals cleanly and accurately. Remove burrs and ease edges to a radius of approximately 1/32 inch unless otherwise indicated. Remove sharp or rough areas on exposed surfaces.
 - c. Form work true to line and level with accurate angles and surfaces.
 - d. Cut, reinforce, drill, and tap as indicated to receive any finish hardware, screws, and similar items.
 - e. Connections: Fabricate railings with welded connections unless otherwise indicated.
 - f. Welded Connections: Cope components at connections to provide close fit, or use fittings designed for this purpose. Weld all around at connections, including at fittings.
 1. Use materials and methods that minimize distortion and develop strength and corrosion resistance of base metals.
 2. Obtain fusion without undercut or overlap.
 3. Remove flux immediately.
 4. At exposed connections, finish exposed surfaces smooth and blended so no roughness shows after finishing and welded surface matches contours of adjoining surfaces. Grind butt welds flush and grind or fill exposed fillet welds to smooth profile. All exposed welds are to be continuous, level and smooth to an Architectural quality finish to the satisfaction of the Architect.
 - g. Bend members in jigs to produce uniform curvature for each configuration required; maintain cross section of member throughout entire bend without buckling, twisting, cracking, or otherwise deforming exposed surfaces of components.
9. Finishes
 - a. All exterior railings and associated components are to be galvanized, primed & painted in accordance with Specification Section 09 91 00 – Painting.
 - b. All interior railings and its associated components are to be primed and painted in accordance with Specification Section 09 91 00 – Painting.

F. Metal ladder

1. Pipe components for ladders shall be constructed of standard steel pipe unless noted otherwise.
2. The design shall be as per drawings.

3. Ladders shall meet all state code and OSHA requirements.
4. Pipe components attached to walls shall be anchored securely.
5. Provide metal materials with smooth surfaces, without seam marks, roller marks, rolled trade names, stains, discolorations, or blemishes.
6. Brackets, Flanges, and Anchors: Cast or formed metal of same type of material and finish as supported rails unless otherwise indicated.
7. Fabrication
 - a. Assemble ladder in the shop to greatest extent possible to minimize field splicing and assembly. Disassemble units only as necessary for shipping and handling limitations. Clearly mark units for reassembly and coordinated installation. Use connections that maintain structural value of joined pieces.
 - b. Cut, drill, and punch metals cleanly and accurately. Remove burrs and ease edges to a radius of approximately 1/32 inch unless otherwise indicated. Remove sharp or rough areas on exposed surfaces.
 - c. Form work true to line and level with accurate angles and surfaces.
 - d. Cut, reinforce, drill, and tap as indicated to receive any finish hardware, screws, and similar items.
 - e. Connections: Fabricate ladder with welded connections unless otherwise indicated.
 - f. Welded Connections: Cope components at connections to provide close fit, or use fittings designed for this purpose. Weld all around at connections, including at fittings.
 - g. Use materials and methods that minimize distortion and develop strength and corrosion resistance of base metals.
 - h. Obtain fusion without undercut or overlap.
 - i. Remove flux immediately.
 - j. At exposed connections, finish exposed surfaces smooth and blended so no roughness shows after finishing and welded surface matches contours of adjoining surfaces. Grind butt welds flush and grind or fill exposed fillet welds to smooth profile. All exposed welds are to be continuous, level and smooth to the satisfaction of the Architect.
 - k. Bend members in jigs to produce uniform curvature for each configuration required; maintain cross section of member throughout entire bend without buckling, twisting, cracking, or otherwise deforming exposed surfaces of components.
8. Finishes: The ladder and its associated components are to be hot dipped galvanized. Galvanized steel will not be painted. All galvanized finish at connections damaged from field assembly or installation to existing materials are to be touched-up as noted below.

G. Metal support framing:

1. Provide metal framing as necessary to support ceiling mounted toilet partition pilasters in accordance with partition manufacturer's instructions and requirements.
2. Provide metal framing as required to support light fixtures, piping, HVAC equipment and ductwork below hard or acoustical ceilings or as required to span across/over/under suspended equipment. Coordinate with the associated MEP contract documents.

3.04 REPAIR OF ZINC COATINGS:

- A. All zinc coatings that have been damaged in handling or transporting or in welding, riveting or bolting shall be repaired by the application of a thick paste made from galvanizing repair

compound conforming to Federal Specification 0-G-93 and water. Areas to be repaired shall be cleaned thoroughly, including removal of slag on welds, before the paste is applied. Surfaces to be coated with paste shall be heated with a torch so that all metallics in the paste will be melted when applied to the heated surfaces. Extreme care shall be taken to see that adjacent zinc-coated surfaces are not damaged by torch. Molten metal shall spread uniformly over all surfaces to be coated and the excess metal wiped off.

3.05 FIELD PAINTING

- A. Specified as scheduled under Section 09 91 00 - Painting.

3.06 DISSIMILAR MATERIAL

- A. Where aluminum comes in contact with metals other than stainless steel, zinc, white bronze or other metals compatible with aluminum, then those surfaces shall be kept from direct contact by painting the dissimilar metal with a coating of heavy-bodied bituminous paint, a good quality caulking placed between the metals, non-absorptive tape or gasket.

END OF SECTION

SECTION 05 51 13

METAL STAIRS

PART 1 - GENERAL

1.01 RELATED DOCUMENTS

- A. Drawings and general provisions of the Contract, including General and Supplementary Conditions and Division 1 Specification Sections, apply to this Section.

1.02 SUMMARY

- A. This Section includes the following:
 - 1. Preassembled steel stairs with concrete-filled treads.
 - 2. Handrails and railings attached to metal stairs.
 - 3. Handrails attached to walls adjacent to metal stairs.
- B. Related Sections include the following:
 - 1. Division 3 Section "Cast-in-Place Concrete" for concrete fill for stair treads and platforms.

1.03 PERFORMANCE REQUIREMENTS

- A. Meet all Federal, State and Local code and law requirements.
- B. Structural Performance: Provide metal stairs capable of withstanding the following structural loads without exceeding the allowable design working stress of the materials involved, including anchors and connections. Apply each load to produce the maximum stress in each component of metal stairs.
 - 1. Treads and Platforms of Metal Stairs: Capable of withstanding a uniform load of 100 lbf/sq. ft..
 - 2. Stair Framing: Capable of withstanding stresses resulting from loads specified above in addition to stresses resulting from railing system loads.
 - 3. Limit deflection of treads, platforms, and framing members to L/360 or 1/4 inch, whichever is less.
- C. Structural Performance of Handrails and Railings: Provide handrails and railings complying with requirements in ASTM E 985 for structural performance, based on testing performed according to ASTM E 894 and ASTM E 935.
- D. Structural Performance of Handrails and Railings: Provide handrails and railings capable of withstanding structural loads required by ASCE 7 without exceeding the allowable design working stress of materials for handrails, railings, anchors, and connections.

1.04 SUBMITTALS

- A. Submit under provisions of Section 01 33 00.
- B. Shop Drawings: Show fabrication and installation details for metal stairs. Include plans, elevations, sections, and details of metal stairs and their connections. Show anchorage and accessory items. Provide templates for anchors and bolts specified for installation under other Sections.

1. For installed products indicated to comply with design loads, include structural analysis data signed and sealed by the qualified professional engineer responsible for their preparation.

C. Welding Certificates: Copies of certificates for welding procedures and personnel.

1.05 QUALITY ASSURANCE

A. Installer Qualifications: Arrange for metal stairs specified in this Section to be fabricated and installed by the same firm.

B. Professional Engineer Qualifications: A professional engineer who is legally qualified to practice in jurisdiction where Project is located and who is experienced in providing engineering services of the kind indicated. Engineering services are defined as those performed for installations of metal stairs (including handrails and railing systems) that are similar to those indicated for this Project in material, design, and extent.

C. Fabricator Qualifications: A firm experienced in producing metal stairs for a minimum of five years similar to those indicated for this Project and with a record of successful in-service performance, as well as sufficient production capacity to produce required units.

D. Welding: Qualify procedures and personnel according to AWS D1.1, "Structural Welding Code--Steel," and AWS D1.3, "Structural Welding Code--Sheet Steel."

1.06 COORDINATION

A. Coordinate installation of anchorages for metal stairs. Furnish setting drawings, templates, and directions for installing anchorages, including sleeves, concrete inserts, anchor bolts, and items with integral anchors, that are to be embedded in concrete or masonry. Deliver such items to Project site in time for installation.

PART 2 - PRODUCTS

2.01 FERROUS METALS

A. Metal Surfaces, General: Provide metal free from pitting, seam marks, roller marks, and other imperfections where exposed to view on finished units. Do not use steel sheet with variations in flatness exceeding those permitted by referenced standards for stretcher-leveled sheet.

B. Steel Plates, Shapes, and Bars: ASTM A 36/A 36M.

C. Steel Tubing: Cold-formed steel tubing complying with ASTM A 500.

D. Steel Pipe: ASTM A 53, standard weight (Schedule 40), unless another weight is indicated or required by structural loads.

E. Rolled-Steel Floor Plate: ASTM A 786/A 786M, rolled from plate complying with ASTM A 36/A 36M or ASTM A 283/A 283M, Grade C or D.

- F. Uncoated, Cold-Rolled Steel Sheet: Commercial quality, complying with ASTM A 366/A 366M; or structural quality, complying with ASTM A 611, Grade A, unless another grade is required by design loads.
- G. Uncoated, Hot-Rolled Steel Sheet: Commercial quality, complying with ASTM A 569/A 569M; or structural quality, complying with ASTM A 570/A 570M, Grade 30, unless another grade is required by design loads.
- H. Welding Rods and Bare Electrodes: Select according to AWS specifications for metal alloy welded.

2.02 FASTENERS

- A. General: Provide zinc-plated fasteners with coating complying with ASTM B 633, Class Fe/Zn 25 for exterior use, and Class Fe/Zn 5 where built into exterior walls. Select fasteners for type, grade, and class required.
- B. Bolts and Nuts: Regular hexagon-head bolts, ASTM A 325, with hex nuts, ASTM A 563; and, where indicated, flat washers.
- C. Lock Washers: Helical, spring type, carbon steel, ASME B18.21.1.
- D. Anchors: Anchor bolts and epoxy with capability to sustain, without failure, a load equal to six times the load imposed when installed in unit masonry or concrete.

2.03 PAINT

- A. Shop Primers: Provide primers that comply with Division 9 Section "Painting."
- B. Shop Primer for Ferrous Metal: Fast-curing, lead- and chromate-free, universal modified-alkyd primer complying with performance requirements in FS TT-P-664, selected for good resistance to normal atmospheric corrosion, compatibility with finish paint systems indicated, and capability to provide a sound foundation for field-applied topcoats despite prolonged exposure.

2.04 GROUT

- A. Nonshrink, Nonmetallic Grout: Factory-packaged, nonstaining, noncorrosive, nongaseous grout complying with ASTM C 1107. Provide grout specifically recommended by manufacturer for interior and exterior applications.

2.05 CONCRETE FILL AND REINFORCING MATERIALS

- A. Concrete Materials and Properties: Comply with requirements in Division 3 Section "Cast-in-Place Concrete" for normal-weight, ready-mixed concrete with a minimum 28-day compressive strength of 3000 psi, unless higher strengths are indicated.
- B. Welded Wire Fabric: ASTM A 185, 6 by 6 inches--W1.4 by W1.4, unless otherwise indicated.

2.06 FABRICATION, GENERAL

- A. Provide complete stair assemblies, including metal framing, hangers, struts, handrails, railings, clips, brackets, bearing plates, and other components necessary to support and anchor stairs and platforms on supporting structure.
 - 1. Join components by welding, unless otherwise indicated.
 - 2. Use connections that maintain structural value of joined pieces.
- B. Form exposed work true to line and level with accurate angles and surfaces and straight sharp edges. Shear and punch metals cleanly and accurately. Remove sharp or rough areas on exposed surfaces.
- C. Ease exposed edges to a radius of approximately 1/32 inch, unless otherwise indicated. Form bent-metal corners to smallest radius possible without causing grain separation or otherwise impairing work.
- D. Weld connections to comply with the following:
 - 1. Use materials and methods that minimize distortion and develop strength and corrosion resistance of base metals.
 - 2. Obtain fusion without undercut or overlap.
 - 3. Remove welding flux immediately.
 - 4. Weld exposed corners and seams continuously, unless otherwise indicated.
 - 5. At exposed connections, finish exposed surfaces smooth and blended so no roughness shows after finishing and welded surface matches contours of adjoining surfaces. Grind butt welds flush and grind or fill exposed fillet welds to smooth profile. All exposed welds are to be continuous, level and smooth to an Architectural quality finish to the satisfaction of the Architect.
- E. Form exposed connections with hairline joints, flush and smooth, using concealed fasteners where possible. Use exposed fasteners of type indicated or, if not indicated, Phillips flat-head (countersunk) screws or bolts. Locate joints where least conspicuous.
- F. Fabricate joints that will be exposed to weather in a manner to exclude water, or provide weep holes where water may accumulate.

2.07 STEEL-FRAMED STAIRS

- A. Stair Framing: Fabricate stringers of structural-steel channels, plates, tube steel or a combination, as indicated. Provide closures for exposed ends of stringers. Construct platforms of structural-steel channel or wide flange headers and miscellaneous framing members as indicated. Bolt or weld headers to stringers; bolt or weld framing members to stringers and headers. If using bolts, fabricate and join so bolts are not exposed on finished surfaces.
 - 1. Where stairs are enclosed by gypsum board shaft-wall assemblies, provide hanger rods to support landings from floor construction above. Locate hanger rods within stud space of shaft-wall construction.
 - 2. Where masonry walls support metal stairs, provide temporary supporting struts designed for erecting steel stair components before installing masonry.
 - 3. Shape metal pans to include nosing integral with riser.

2.08 STEEL TUBE HANDRAILS AND RAILINGS

- A. Provide steel tube handrails and railings on all stairs except as noted otherwise in the construction documents.
- B. General: Fabricate handrails and railings to comply with requirements indicated for design, dimensions, details, finish, and member sizes, including wall thickness of tube, post spacings, and anchorage, but not less than that needed to withstand indicated loads. See drawings for design.
- C. Interconnect members by butt-welding or welding with internal connectors, at fabricator's option, unless otherwise indicated.
- D. Form simple and compound curves by bending members in jigs to produce uniform curvature for each repetitive configuration required; maintain cross section of member throughout entire bend without buckling, twisting, cracking, or otherwise deforming exposed surfaces of components.
- E. Close exposed ends of handrail and railing members with prefabricated end fittings.
- F. Provide wall returns at ends of wall-mounted handrails, unless otherwise indicated. Close ends of returns, unless clearance between end of rail and wall is 1/4 inch or less.
- G. Brackets, Flanges, Fittings, and Anchors: Provide wall brackets, end closures, flanges, miscellaneous fittings, and anchors for interconnecting railings and for attaching to other work. Furnish inserts and other anchorage devices for connecting to concrete or masonry work.
 - 1. Connect railing posts to stair framing by direct welding, unless otherwise indicated.
- H. Fillers: Provide fillers made from steel plate, or other suitably crush-resistant material, where needed to transfer wall bracket loads through wall finishes to structural supports. Size fillers to suit wall finish thicknesses and to produce adequate bearing area to prevent bracket rotation and overstressing of substrate.
 - 1. Connect railing posts to stair framing by direct welding, unless otherwise indicated.

2.09 FINISHES

- A. Comply with NAAMM'S "Metal Finishes Manual for Architectural and Metal Products" for recommendations for applying and designating finishes.
- B. Finish metal stairs after assembly.
- C. Preparation for Shop Priming: Prepare uncoated ferrous-metal surfaces to comply with minimum requirements indicated below for SSPC surface-preparation specifications and environmental exposure conditions of installed products:
 - 1. Interiors (SSPC Zone 1A): SSPC SP 3, "Power Tool Cleaning."
- D. Apply shop primer to prepared surfaces of metal stair components, unless otherwise indicated. Comply with SSPC-PA 1, "Paint Application Specification No. 1," for shop painting. Primer need not be applied to surfaces to be embedded in concrete or masonry.

PART 3 - EXECUTION

3.01 INSTALLATION, GENERAL

- A. Fastening to In-Place Construction: Provide anchorage devices and fasteners where necessary for securing metal stairs to in-place construction. Include threaded fasteners for concrete and masonry inserts, through-bolts, lag bolts, and other connectors.
- B. Cutting, Fitting, and Placement: Perform cutting, drilling, and fitting required for installing metal stairs. Set units accurately in location, alignment, and elevation, measured from established lines and levels and free from rack.
- C. Install metal stairs by welding stair framing to steel structure or to weld plates cast into concrete, unless otherwise indicated.
- D. Provide temporary bracing or anchors in formwork for items that are to be built into concrete, masonry, or similar construction.
- E. Fit exposed connections accurately together to form hairline joints. Weld connections that are not to be left as exposed joints but cannot be shop welded because of shipping size limitations. Do not weld, cut, or abrade surfaces of exterior units that have been hot-dip galvanized after fabrication and are for bolted or screwed field connections.
- F. Field Welding: Comply with the following requirements:
 - 1. Use materials and methods that minimize distortion and develop strength and corrosion resistance of base metals.
 - 2. Obtain fusion without undercut or overlap.
 - 3. Remove welding flux immediately.
 - 4. At exposed connections, finish exposed welds and surfaces smooth and blended so no roughness shows after finishing and contour of welded surface matches that of adjacent surface.

3.02 INSTALLING STEEL TUBE RAILINGS AND HANDRAILS

- A. Adjust handrails and railing systems before anchoring to ensure matching alignment at abutting joints. Space posts at spacing indicated or, if not indicated, as required by design loads. Plumb posts in each direction. Secure posts and railing ends to building construction as follows:
 - 1. Anchor posts to steel by welding directly to steel supporting members.
- B. Attach handrails to wall with wall brackets. Provide bracket with 2 1/4-inch clearance from inside face of handrail and finished wall surface. Locate brackets as indicated or, if not indicated, at spacing required to support structural loads. Secure wall brackets to building construction as follows:
 - 1. Use type of bracket with flange tapped for concealed anchorage to threaded hanger bolt.
 - 2. For concrete and solid masonry anchorage, use drilled-in expansion shields and hanger.
 - 3. For hollow masonry anchorage, use toggle bolts.
 - 4. For steel-framed gypsum board assemblies, fasten brackets directly to steel framing or concealed reinforcements using self-tapping screws of size and type required to support structural loads.

3.03 ADJUSTING AND CLEANING

- A. Touchup Painting: Immediately after erection, clean field welds, bolted connections, and abraded areas of shop paint, and paint exposed areas with the same material as used for shop painting to comply with SSPC-PA 1 for touching up shop-painted surfaces.
 - 1. Apply by brush or spray to provide a minimum 2.0-mil dry film thickness.
- B. Touchup Painting: Cleaning and touchup painting of field welds, bolted connections, and abraded areas of shop paint are specified in Division 9 Section "Painting."

END OF SECTION

THIS PAGE INTENTIONALLY LEFT BLANK

SECTION 05 73 16

ORNAMENTAL CABLE RAILINGS

PART 1 GENERAL

1.1 SUMMARY

- A. Related Documents:
The Drawings and general provisions of the Contract, including General and Supplementary General Conditions, and Division 1 Requirements, apply to the work in this Section.

1.2 SECTION INCLUDES

- A. Ornamental stainless steel cable railing system.

1.3 REFERENCES

- A. ASTM International (ASTM):
 1. ASTM A 554 - Standard Specification for Welded Stainless Steel Mechanical Tubing.
 2. ASTM A 492 - Standard Specification for Stainless Steel Rope Wire.

1.4 SUBMITTALS

- A. Submit under provisions of Section 01 33 00.
- B. Product Data: Manufacturer's specifications and technical data including the following:
 1. Detailed specification of construction and fabrication.
 2. Manufacturer's installation instructions.
- C. Shop Drawings: Submit shop drawings for fabrication and installation. Include the following:
 1. Plans, elevations, and detail sections.
 2. Indicate materials, methods, finishes, and types of joinery, fasteners, anchorages, and accessory items.
 3. Where materials or fabrications are indicated to comply with certain design loadings, include structural computations, material properties, and other information needed for structural analysis.
- D. Samples: Prepare samples on metal of same alloy and thickness to be used for the Work if requested by the Architect.
- E. Quality Control Submittals: Statement of manufacturer's qualifications.

1.5 QUALITY ASSURANCE

- A. Manufacturer's Qualifications: Not less than 10 years experience in the actual production of specified products.
- B. Installer's Qualifications: Firm with demonstrated experience in installation of systems similar in complexity to those required for this Project.

1.6 DELIVERY, STORAGE, AND HANDLING

- A. Deliver, store, protect and handle products to site under provisions of Section 01 60 00.
- B. Deliver, store and handle materials and products in strict compliance with manufacturer's instructions and recommendations and industry standards.
- C. Store materials in manufacturer's original sealed, labeled packaging until ready for installation and in accordance with manufacturer's instructions. Protect from damage.

1.7 PROJECT CONDITIONS

- A. Maintain environmental conditions (temperature, humidity, and ventilation) within limits recommended by manufacturer for optimum results. Do not install products under environmental conditions outside manufacturer's recommended limits.

1.8 REGULATORY REQUIREMENTS

- A. Conform to all applicable Federal, State and local codes and laws.

1.9 WARRANTY

- A. Manufacturer's Warranty: Provide manufacturer's standard 3 year limited warranty under the provisions of Section 01 78 00.

PART 2 PRODUCTS

2.1 MANUFACTURERS

- A. Acceptable Manufacturer: AGS Stainless, Inc. - Cable Rail, which is located at: 7873 N. E. Day Rd.; Bainbridge Island, WA 98110; Toll Free Tel: 888-842-9492; Tel: 206-842-9492; Fax: 206-842-8179 ; Email:[request info \(info@agsstainless.com\)](mailto:info@agsstainless.com);
Web:www.agsstainless.com

Model: Rainier

- B. Requests for substitutions will be considered in accordance with provisions of Section 01 60 00.

2.2 SYSTEM DESCRIPTION - GENERAL

- A. Custom, shop-fabricated stainless steel railing frame with mechanical fittings and attachment for field installation.
 - 1. Infill: Horizontal cabling.
- B. Shop fabricate such that no jobsite welding, grinding or cutting is required.

2.3 STAINLESS STEEL RAILING SYSTEMS

- A. Stainless Steel Railing System: Clearview Railing System as manufactured by AGS Stainless, Inc.
 - 1. Type: Rainier - Cable railing.
 - 2. Fabrication: Factory welded components. Verify dimensions on site prior to shop fabrication.

- a. Mill joints to a tight, hairline fit.
 - b. Miter corner joints.
 3. Structural Requirements: Fabricate integral railings and component connections to meet or exceed the requirements as set forth in the current, adopted ICC International Building Code (IBC), and governing local code as applicable.
- B. Posts:
1. Post Material: ASTM A 554, Type A316 stainless steel, minimum Fy=40 ksi.
 2. Post Size: 1-1/2 inch (38.1 mm) x 1-1/2 inch (38.1 mm).
 3. Post Mounting Configuration: Top mount, as indicated on installation Drawings.
- C. Top Rails:
1. Top Rail Material: ASTM A 554, Type A316 stainless steel, minimum Fy=40 ksi.
 2. Top Rail Shape, Size: Round, 1-5/8 inch (15.8 mm) diameter x 16 gauge tubing.
 3. Infill - Cables
 - a. Material: ASTM A 492, stainless steel, Type 316.
 - b. Construction: 1 X 19.
 - c. Diameter: 1/8 inch (3 mm) diameter.
 - d. Lay: Left Hand Lang's.
 - e. Core: Stainless steel.
 - f. Cables provided in lengths approximately six inches longer than required for their designated run with fitting attached at one end; requires one end of each length of cable to be field cut and fittings field attached.
 - g. Cable Fitting Materials: Stainless steel, Type 316.
 - h. Cable Attachments: Factory, machine swaged or field, hand swaged.
 - i. Tensioning Method: Threaded terminals.
- D. Finish to be powder coat in color selected by Architect from manufacturer's standard colors.

PART 3 EXECUTION

3.1 EXAMINATION AND PREPARATION

- A. Do not proceed with installation until substrates have been properly prepared and deviations from manufacturer's recommended tolerances are corrected. Prepare surfaces using the methods recommended by the manufacturer for achieving the best result for the substrate under the project conditions.
- B. Commencement of installation constitutes acceptance of conditions.

3.2 INSTALLATION

- A. Install railing system plumb, level, and true and in accordance with manufacturer's installation instructions and recommendations.
- B. Do not tighten the cables more than what is necessary to eliminate any sag.
- C. Provide anchorage devices and fittings to secure to in-place construction to adjacent construction. Separate dissimilar materials with bushings, grommets or washers to prevent electrolytic corrosion.
- D. Do not cut components, except for cable as required for installation, or abrade component finishes. Field touch-up of finishes only acceptable if done as per manufacturer's

recommendations. Return components with damaged finishes to shop for required alterations according to manufacturer's return policy, followed by complete refinishing or provide new components.

- E. Secure mounting brackets to building structure in a positive manner using manufacturer recommended reinforcement and anchorage methods for substrate conditions. Locate brackets and hardware at spacing required to support structural loads.
- F. Installation of railing system shall be rigid and secure, installed by mechanics experienced in erection of architectural metal. Mounting hardware shall be drawn up tightly. Rails shall be set plumb and aligned.

3.3 CLEANING

- A. Clean under provisions of Section 01 70 00.

3.4 PROTECTION OF FINISHED WORK

- A. Protect finished product and work under provisions of Section 01 70 00.

END OF SECTION

SECTION 06 10 00

ROUGH CARPENTRY

PART 1 - GENERAL

1.1 RELATED DOCUMENTS

- A. Drawings and general provisions of the Contract, including General and Supplementary Conditions and Division 1 Specification Sections, apply to this Section.

1.2 SUMMARY

- A. This Section includes the following:
1. Framing with dimension lumber.
 2. Framing with engineered wood products.
 3. Wood blocking, cants, and nailers.
 4. Building wrap.
- B. Related Sections include the following:
1. Division 6 Section "Finish Carpentry" for nonstructural carpentry items exposed to view and not specified in another Section.

1.3 DEFINITIONS

- A. Rough Carpentry: Carpentry work not specified in other Sections and not exposed, unless otherwise indicated.
- B. Exposed Framing: Dimension lumber not concealed by other construction.
- C. Lumber grading agencies, and the abbreviations used to reference them, include the following:
1. NELMA - Northeastern Lumber Manufacturers Association.
 2. NLGA - National Lumber Grades Authority.
 3. RIS - Redwood Inspection Service.
 4. SPIB - Southern Pine Inspection Bureau.
 5. WCLIB - West Coast Lumber Inspection Bureau.
 6. WWPA - Western Wood Products Association.

1.4 SUBMITTALS

- A. Product Data: For each type of process and factory-fabricated product. Indicate component materials and dimensions and include construction and application details.

1. Include data for wood-preservative treatment from chemical treatment manufacturer and certification by treating plant that treated materials comply with requirements. Indicate type of preservative used, net amount of preservative retained, and chemical treatment manufacturer's written instructions for handling, storing, installing, and finishing treated material.
 2. Include data for fire-retardant treatment from chemical treatment manufacturer and certification by treating plant that treated materials comply with requirements. Include physical properties of treated materials, both before and after exposure to elevated temperatures when tested according to ASTM D 5516 and ASTM D 5664.
 3. For products receiving a waterborne treatment, include statement that moisture content of treated materials was reduced to levels specified before shipment to Project site.
 4. Include copies of warranties from chemical treatment manufacturers for each type of treatment.
- B. Material Certificates: For dimension lumber specified to comply with minimum allowable unit stresses. Indicate species and grade selected for each use and design values approved by the American Lumber Standards Committee Board of Review.
- C. Research/Evaluation Reports: For the following, showing compliance with building code in effect for Project:
1. Preservative-treated wood.
 2. Engineered wood products.
 3. Power-driven fasteners.
 4. Powder-actuated fasteners.
 5. Expansion anchors.
 6. Metal framing anchors.
 7. Building wrap.

1.5 QUALITY ASSURANCE

- A. Testing Agency Qualifications: An independent testing agency, acceptable to authorities having jurisdiction, with the experience and capability to conduct the testing indicated, as documented according to ASTM E 548.
- B. Source Limitations for Engineered Wood Products: Obtain each type of engineered wood product through one source from a single manufacturer.

1.6 DELIVERY, STORAGE, AND HANDLING

- A. Stack lumber, plywood, and other panels; place spacers between each bundle to provide air circulation. Provide for air circulation around stacks and under coverings.

PART 2 - PRODUCTS

2.1 MANUFACTURERS

- A. Available Manufacturers: Subject to compliance with requirements, manufacturers offering products that may be incorporated into the Work include, but are not limited to, the following:
1. LVL:
 - a. Trus Joist MacMillan.
 2. Building Wrap:
 - a. Celotex Corporation (The); Building Products Division.
 - b. DuPont (E. I. du Pont de Nemours and Company).
 - c. Parsec, Inc.
 - d. Raven Industries, Inc.
 - e. Reemay, Inc.
 - f. Simplex Products.
 - g. Sto-Cote Products, Inc.
 - h. Tenneco Building Products.
 3. Metal Framing Anchors:
 - a. Alpine Engineered Products, Inc.
 - b. Cleveland Steel Specialty Co.
 - c. Harlen Metal Products, Inc.
 - d. KC Metals Products, Inc.
 - e. Silver Metal Products, Inc.
 - f. Simpson Strong-Tie Company, Inc.
 - g. Southeastern Metals Manufacturing Co., Inc.
 - h. United Steel Products Company, Inc.

2.2 WOOD PRODUCTS, GENERAL

- A. Lumber: DOC PS 20 and applicable rules of lumber grading agencies certified by the American Lumber Standards Committee Board of Review.
1. Factory mark each piece of lumber with grade stamp of grading agency.
 2. Where nominal sizes are indicated, provide actual sizes required by DOC PS 20 for moisture content specified. Where actual sizes are indicated, they are minimum dressed sizes for dry lumber.
 3. Provide dressed lumber, S4S, unless otherwise indicated.
 4. Provide dry lumber with 19 percent maximum moisture content at time of dressing for 2-inch nominal thickness or less, unless otherwise indicated.

- B. Engineered Wood Products: Provide engineered wood products acceptable to authorities having jurisdiction and for which current model code research or evaluation reports exist that show compliance with building code in effect for Project.
 - 1. Allowable Design Stresses: Provide engineered wood products with allowable design stresses, as published by manufacturer, that meet or exceed those indicated. Manufacturer's published values shall be determined from empirical data or by rational engineering analysis and demonstrated by comprehensive testing performed by a qualified independent testing agency.

2.3 WOOD-PRESERVATIVE-TREATED MATERIALS

- A. Dimension Lumber. Preservative Treatment by Pressure Process: AWPAC2 (lumber) and AWPAC9 (plywood), except that lumber that is not in contact with the ground and is continuously protected from liquid water may be treated according to AWPAC31 with inorganic boron (SBX).
 - 1. Preservative Chemicals: Acceptable to authorities having jurisdiction and one of the following:
 - a. Chromated copper arsenate (CCA).
 - b. Ammoniacal copper zinc arsenate (ACZA).
 - c. Ammoniacal, or amine, copper quat (ACQ).
 - d. Copper bis (dimethyldithiocarbamate) (CDDC).
 - e. Ammoniacal copper citrate (CC).
 - f. Copper azole, Type A (CBA-A).
 - g. Oxine copper (copper-8-quinolinolate) in a light petroleum solvent.
 - 2. For exposed items indicated to receive a stained or natural finish, use chemical formulations that do not require incising, contain colorants, bleed through, or otherwise adversely affect finishes.
- B. Kiln-dry material after treatment to a maximum moisture content of 19 percent for lumber and 15 percent for plywood. Do not use material that is warped or does not comply with requirements for untreated material.
- C. Mark each treated item with the treatment quality mark of an inspection agency approved by the American Lumber Standards Committee Board of Review.
 - 1. For exposed lumber indicated to receive a stained or natural finish, mark end or back of each piece, or omit marking and provide certificates of treatment compliance issued by inspection agency.
- D. Application: Treat items indicated on Drawings, and the following:

2.4 DIMENSION LUMBER

- A. General: Provide dimension lumber of grades indicated according to the American Lumber Standards Committee National Grading Rule provisions of the grading agency indicated.

2.5 MISCELLANEOUS LUMBER

- A. General: Provide lumber for support or attachment of other construction, including the following:
 - 1. Blocking.
 - 2. Cants.
 - 3. Nailers.
 - 4. Furring.
 - 5. Grounds.
- B. For items of dimension lumber size, provide Construction, Stud, or No. 2 grade lumber with 19 percent maximum moisture content and any of the following species:
 - 1. Mixed southern pine; SPIB.
 - 2. Hem-fir or Hem-fir (north); NLGA, WCLIB, or WWPA.
 - 3. Spruce-pine-fir (south) or Spruce-pine-fir; NELMA, NLGA, WCLIB, or WWPA.
 - 4. Eastern softwoods; NELMA.
 - 5. Northern species; NLGA.
 - 6. Western woods; WCLIB or WWPA.

2.6 ENGINEERED WOOD PRODUCTS

- A. Laminated-Veneer Lumber: A composite of wood veneers with grain primarily parallel to member lengths, manufactured with an exterior-type adhesive complying with ASTM D 2559. Product has the following allowable design values as determined according to ASTM D 5456:
 - 1. Extreme Fiber Stress in Bending, Edgewise: 2,600 psi (17.9 MPa) for 12-inch nominal- (286-mm actual-) depth members.
 - 2. Modulus of Elasticity, Edgewise: 1,900,000 psi (13,100 MPa).
- B. Rim Boards: Performance-rated product complying with APA PRR-401.
 - 1. Material: Mat-formed panels or LVL as shown on drawings.
 - 2. Thickness and Grade: 1 1/4-inch (31 mm) rim board.
 - 3. Trademark: Factory mark with APA trademark indicating thickness, grade, and compliance with APA standard.

2.7 FASTENERS

- A. General: Provide fasteners of size and type indicated that comply with requirements specified in this Article for material and manufacture.

1. Where rough carpentry is exposed to weather, in ground contact, or in area of high relative humidity, provide fasteners with hot-dip zinc coating complying with ASTM A 153/A 153M.
- B. Nails, Brads, and Staples: ASTM F 1667.
- C. Power-Driven Fasteners: CABO NER-272.
- D. Wood Screws: ASME B18.6.1.
- E. Screws for Fastening to Cold-Formed Metal Framing: ASTM C 954, except with wafer heads and reamer wings, length as recommended by screw manufacturer for material being fastened.
- F. Lag Bolts: ASME B18.2.1.
- G. Bolts: Steel bolts complying with ASTM A 307, Grade A; with ASTM A 563 hex nuts and, where indicated, flat washers.
- H. Expansion Anchors: Anchor bolt and sleeve assembly of material indicated below with capability to sustain, without failure, a load equal to 6 times the load imposed when installed in unit masonry assemblies and equal to 4 times the load imposed when installed in concrete as determined by testing per ASTM E 488 conducted by a qualified independent testing and inspecting agency.
 1. Material: Carbon-steel components, zinc plated to comply with ASTM B 633, Class Fe/Zn 5.

2.8 METAL FRAMING ANCHORS

- A. General: Provide framing anchors made from metal indicated, of structural capacity, type, and size indicated, and as follows:
 1. Research/Evaluation Reports: Provide products acceptable to authorities having jurisdiction and for which model code research/evaluation reports exist that show compliance of metal framing anchors, for application indicated, with building code in effect for Project.
 2. Allowable Design Loads: Provide products with allowable design loads, as published by manufacturer, that meet or exceed those indicated. Manufacturer's published values shall be determined from empirical data or by rational engineering analysis and demonstrated by comprehensive testing performed by a qualified independent testing agency.
- B. Galvanized Steel Sheet: Z-max (G185) corrosion-resistant coating.
- C. Bridging: Rigid, V-section, nailless type, 0.062 inch thick, length to suit joist size and spacing.

- D. Post Bases: Adjustable-socket type for bolting in place with standoff plate to raise post 1 inch above base and with 2-inch-minimum side cover, socket 0.062 inch thick, and standoff and adjustment plates 0.108 inch thick.
- E. Rafter Tie-Downs (Hurricane or Seismic Ties): Bent strap tie for fastening rafters or roof trusses to wall studs below, 2-1/4 inches wide by 0.062 inch thick. Tie fits over top of rafter or truss and fastens to both sides of rafter or truss, face of top plates, and side of stud below.

2.9 MISCELLANEOUS MATERIALS

- A. Building Paper: Asphalt-saturated organic felt complying with ASTM D 226, Type I (No. 15 asphalt felt), unperforated.
- B. Building Wrap: Air-retarder sheeting made from polyolefins; cross-laminated films, woven strands, or spun-bonded fibers; coated or uncoated; with or without perforations; and complying with ASTM E 1677, Type I.
 - 1. Thickness: Not less than 3 mils.
 - 2. Permeance: Not less than 10 perms.
 - 3. Flame-Spread Index: 25 or less per ASTM E 84.
 - 4. Allowable Exposure Time: Not less than three months.
- C. Building Wrap Tape: Pressure-sensitive plastic tape recommended by building wrap manufacturer for sealing joints and penetrations in building wrap.
- D. Sill-Sealer Gaskets: Closed-cell neoprene foam, 1/4 inch thick, selected from manufacturer's standard widths to suit width of sill members indicated.
- E. Water-Repellent Preservative: NWWDA-tested and -accepted formulation containing 3-iodo-2-propynyl butyl carbamate, combined with an insecticide containing chloropyrifos as its active ingredient.

PART 3 - EXECUTION

3.1 INSTALLATION, GENERAL

- A. Set rough carpentry to required levels and lines, with members plumb, true to line, cut, and fitted. Fit rough carpentry to other construction; scribe and cope as needed for accurate fit. Locate nailers, blocking, and similar supports to comply with requirements for attaching other construction.
- B. Do not use materials with defects that impair quality of rough carpentry or pieces that are too small to use with minimum number of joints or optimum joint arrangement.
- C. Apply field treatment complying with AWWPA M4 to cut surfaces of preservative-treated lumber and plywood.

- D. Securely attach rough carpentry work to substrate by anchoring and fastening as indicated, complying with the following:
 - 1. CABO NER-272 for power-driven fasteners.
 - 2. Published requirements of metal framing anchor manufacturer.
 - 3. Table 23-II-B-1, "Nailing Schedule," and Table 23-II-B-2, "Wood Structural Panel Roof Sheathing Nailing Schedule," in the Uniform Building Code.
 - 4. Table 2304.9.1, "Fastening Schedule," in the International Building Code.
- E. Use common wire nails, unless otherwise indicated. Select fasteners of size that will not fully penetrate members where opposite side will be exposed to view or will receive finish materials. Make tight connections between members. Install fasteners without splitting wood; predrill as required.
- F. Use finishing nails for exposed work, unless otherwise indicated. Countersink nail heads and fill holes with wood filler.

3.2 WOOD SLEEPER, BLOCKING, AND NAILER INSTALLATION

- A. Install where indicated and where required for attaching other work. Form to shapes indicated and cut as required for true line and level of attached work. Coordinate locations with other work involved.
- B. Attach items to substrates to support applied loading. Recess bolts and nuts flush with surfaces, unless otherwise indicated. Where possible, secure anchor bolts to formwork before concrete placement.

3.3 WOOD FRAMING INSTALLATION, GENERAL

- A. Framing Standard: Comply with AFPA's "Manual for Wood Frame Construction," unless otherwise indicated.
- B. Framing with Engineered Wood Products: Install engineered wood products to comply with manufacturer's written instructions.
- C. Do not splice structural members between supports.
- D. Where built-up beams or girders of 2-inch nominal-dimension lumber on edge are required, fasten together with 2 rows of 20d nails spaced not less than 16 inches o.c. Locate one row near top edge and other near bottom edge.

3.4 WALL AND PARTITION FRAMING INSTALLATION

- A. General: Arrange studs so wide face of stud is perpendicular to direction of wall or partition and narrow face is parallel. Anchor or nail plates to supporting construction, unless otherwise indicated.

1. For exterior walls, provide 2-by-6-inch nominal size wood studs spaced 16 inches o.c., unless otherwise indicated.
 2. For interior partitions and walls, provide 2-by-4-inch nominal- size wood studs spaced 16 inches o.c., unless otherwise indicated. Refer to architectural floor plan and wall type schedule for additional information.
- B. Construct corners and intersections with three or more studs. Provide blocking and framing as indicated and as required to support facing materials, fixtures, specialty items, and trim.
1. Provide continuous horizontal blocking at midheight of partitions more than 96 inches high, using members of 2-inch nominal thickness and of same width as wall or partitions.
- C. Frame openings with multiple studs and headers. Provide nailed header members of thickness equal to width of studs. Set headers on edge and support on jamb studs.
1. For non-load-bearing partitions, provide double-jamb studs with headers not less than 4-inch nominal depth for openings 48 inches and less in width, 6-inch nominal depth for openings 48 to 72 inches in width, 8-inch nominal depth for openings 72 to 120 inches in width, and not less than 10-inch nominal depth for openings 10 to 12 feet in width.
 2. For load-bearing walls, provide jamb studs as specified in the construction documents.

3.5 BUILDING PAPER APPLICATION

- A. Apply building paper horizontally with 2-inch overlap and 6-inch end lap; fasten to sheathing with galvanized staples or roofing nails. Cover upstanding flashing with 4-inch overlap.

3.6 BUILDING WRAP APPLICATION

- A. Cover wall sheathing with building wrap as indicated.
1. Comply with manufacturer's written instructions.
 2. Cover upstanding flashing with 4-inch overlap.
 3. Seal seams, edges, and penetrations with tape.
 4. Extend into jambs of openings and seal corners with tape.

END OF SECTION 06 10 00

THIS PAGE INTENTIONALLY LEFT BLANK

SECTION 06 16 13

STRUCTURAL INSULATED PANELS

PART 1 – GENERAL

1.1 RELATED DOCUMENTS

- A. Drawings and general provisions of the Contract, including General and Supplementary Conditions and Division 1 Specification Sections, apply to this Section.

1.2 SUMMARY

- A. This Section includes Structural Insulated Roof Panels (SIP).

1.3 PERFORMANCE REQUIREMENTS

- A. Structural Performance: Provide SIPs capable of withstanding design loads including dead load, live loads and wind loads. Design loads shall be in compliance with the requirements of the state Building Code.

1.4 SUBMITTALS

- A. Submit under provisions of Section 01 33 00.
- B. Product Data: SIP manufacturer's product literature including structural properties and installation instructions.
- C. Shop Drawings: Show fully dimensioned fabrication and installation details for SIPs.
- D. Samples: Submit samples of panel materials, fasteners and misc. accessories.

1.5 QUALITY ASSURANCE

- A. SIP Manufacturer shall be a member of the Structural Insulated Panel Association (SIPA).
- B. Installation Contractor must have experience on projects of similar size and scope. Lead installer / supervisor shall have a minimum of 3 years experience installing SIPs or have completed a certifying curriculum at a dedicated SIP training program.

1.6 DELIVERY, STORAGE, AND HANDLING

- A. Deliver, store, protect and handle products to site under provisions of Section 01 60 00.
- B. SIPs shall be kept dry and protected with waterproof covering during transportation and storage.
- C. Exercise care to prevent crushing of SIP edges with cargo hold down straps during transportation.
- D. Carefully load and unload SIPs from trucks to prevent damage to the panels.

- E. Store SIPs elevated off of the ground on sleepers.
- F. Take care in handling SIPs to prevent delamination.

1.7 COORDINATION

- A. Time delivery and installation of SIPs to avoid extended on-site storage and to avoid delaying progress of other trades whose work must follow the installation of SIPs.

1.8 PRE-INSTALLATION MEETING

- A. Conduct pre-installation meeting one week prior to commencing work of this section and on site installations to verify project requirements, substrate conditions, coordination with building sub trades, SIP installation instructions and warranty requirements.

PART 2 – PRODUCTS

2.1 MANUFACTURERS

- A. Foard Panel, West Chesterfield, NH 03466 800-644-8885
- B. Substitutions: Under provisions of Section 01 60 00.

2.2 STRUCTURAL INSULATED (XPS) ROOF PANELS:

- A. Oriented Strand Board (OSB): 7/16” thick minimum. OSB shall comply with APA PR-N610 and ANSI PRS-610.
- B. Extruded (XPS) Polystyrene Core: shall comply with ASTM C518 and shall have a minimum density of 1.5 pcf for XPS.
- C. Adhesive: ASTM D2559.
- D. Joint materials: - materials for use in joining panels shall be selected for structural requirements of this application.
- E. System characteristics/material/performance standards as follows:
 - 1. Sizes – 4ft & 8ft wide x length required.
 - 2. Thermal Resistance (R-Value) of roof panel shall be as shown on the drawings.
 - 3. For pre cut panels, fabricate panel system to dimension, size and profile indicated on the drawings.

2.3 LUMBER

- A. Grade and Species: Visually graded dimension lumber No. 2 or better of any of the following species:
 - 1. Spruce-Pine-Fir; NLGA
 - 2. Hem-Fir (North); WCLIB or WWPA
 - 3. Douglas Fir – Larch; WCLIB or WWPA
 - 4. Southern Pine; SPIB

- B. Lumber shall be kiln dried to not more than 19% moisture content
- C. Lumber shall be clearly marked with grade stamp of grading agency.
- D. Engineered wood products shall be used where required for structural adequacy.
 - 1. Laminated Veneer Lumber (LVL)
 - 2. Parallel Strand Lumber (PSL)
 - 3. Laminated Strand Lumber (LSL)
 - 4. Gluelam (GL)

2.4 FASTENERS

- A. Common Nails: ASTM F1667.
- B. Panel Screws: screws with pancake heads by one of the following manufacturers:
 - 1. OMG - Fastenmaster

2.5 FABRICATION

- A. Cut SIPs to accurate lengths, angles, and sizes to produce close fitting joints.
- B. Remove foam as required to accommodate wood blocking and splines.

PART 3 – EXECUTION

3.1 PREPARATION

- A. Examine framing and other surfaces to receive SIPs and verify that conditions are suitable for the installation of SIPs. Report any unsatisfactory conditions to the Contractor. Do not proceed with installation until unsatisfactory conditions have been corrected.

3.2 INSTALLATION

- A. Hoist SIPs in place by lifting equipment suited to size of panels. Exercise care to prevent damage to SIPs.
- B. Install SIPs plumb, square and true to line.
- C. Fill all panel joints with expanding urethane foam or seal by other approved method.
- D. Repair or replace all damaged SIPs.
- E. Deposit packing and excess panel materials in appropriate container on site for recycling or reuse. Avoid using landfill waste disposal procedures when recycling facilities are available.
- F. General contractor should not allow product to be exposed to the weather for more than 30 days after installation. Install building/ roofing wrap within 3-5 days after panels are installed.

3.3 CLEANING

- A. Clean under provisions of Section 01 70 00.

3.4 PROTECTION OF FINISHED WORK

- A. Protect finished product and work under provisions of Section 01 70 00.

END OF SECTION

SECTION 06 16 15

COMPOSITE NAIL BASE INSULATING SHEATHING

PART 1 – GENERAL

1.1 SUMMARY

- A. Related Documents: Drawings and general provisions of the Contract, including General and Supplementary Conditions and Division 1 Specification Sections, apply to this Section.
- B. Section Includes, without limitation, providing:
 - 1. Composite nail base insulating sheathing for exterior walls.
 - 2. Integral water and air infiltration barrier.

1.2 SUBMITTALS

- A. Submit under provisions of Section 01 33 00.
- B. Product Data: For each type of process and factory-fabricated product. Indicate component materials and dimensions and include construction and application details.

1.3 QUALITY ASSURANCE

- A. Provide wall sheathing products meeting requirements for water-resistive barrier in accordance with ICC-ES AC310.
- B. Provide wall sheathing products meeting requirements of ICC-ES AC269.

1.4 DELIVERY, STORAGE, AND HANDLING

- A. Deliver, store, handle and protect products to site under provisions of Section 01 60 00.
- B. Stack panels flat with spacers beneath and between each bundle to provide air circulation. Protect sheathing from weather by covering with waterproof, vented sheeting, securely anchored. Provide for air circulation around stacks and under coverings. Protect from sunlight and UV radiation.

1.5 WARRANTY

- A. Special Manufacturer's Warranty: Manufacturer's standard form in which sheathing manufacturer agrees to repair or replace sheathing products that demonstrate deterioration or failure under normal use due to manufacturing defects within warranty period specified, when installed according to manufacturer's instructions.
 - 1. Warranty Period for Sheathing Products: 3 years following date of Substantial Completion.
- B. Warranty Conditions: Special warranties exclude deterioration or failure due to structural movement resulting in stresses on sheathing products exceeding manufacturer's written specifications, or due to air or moisture infiltration resulting from cladding failure or mechanical damage.

PART 2 - PRODUCTS

2.1 PERFORMANCE REQUIREMENTS

- A. Comply with the following exposure, air and water resistance criteria:
 - 1. Air-Barrier Assembly Air Leakage: Less than 0.04 cfm/sq. ft. at 1.57 lbf/sq. ft. (0.2 L/s x sq. m at 75 Pa), per ASTM E2375.
 - 2. Water-Vapor Permeance, Facer: Minimum 12 perms (689 ng/Pa x s x sq. m), ASTM E96/E96M.
 - 3. Weather Exposure: Manufacturer warranty applies for maximum allowable exposure period of 180 days.
- B. Fire-Test-Response Characteristics: Where shown, at fire rated assemblies, provide materials and construction identical to tested assemblies, including:
 - 1. UL's "Fire Resistance Directory."
 - 2. GA-600, "Fire Resistance Design Manual."
 - 3. NFPA 285.

2.2 WOOD PANEL PRODUCTS - GENERAL

- A. Comply with the following:
 - 1. Plywood: DOC PS 1.
 - 2. Treated plywood: Refer to Section 06 20 10.
 - 3. Oriented Strand Board: DOC PS 2.
 - 4. Thickness: As needed to comply with requirements specified, but not less than thickness indicated.
 - 5. Factory mark panels to indicate compliance with applicable standard.

2.3 COMPOSITE NAIL BASE INSULATING OSB SHEATHING WITH INTEGRATED AIR/MOISTURE BARRIER

- A. Type 1 Not vented:
 - 1. Manufacturers: Subject to compliance with requirements, include the following]:
 - a. Huber Engineered Woods; www.zipsystem.com.
 - b. Other acceptable manufacturers offering equivalent products:
 - 1) Composite Panel Building Systems
 - 2) Hunter Panels
 - c. Approved equal under provisions of Section 01 60 00.
 - 2. Basis of Design: Huber "Zip System R Sheathing Wall Sheathing", as follows:
 - a. Oriented-strand-board Exposure 1 sheathing of indicated thickness, with factory-laminated water-resistive barrier exterior facer, and with rigid foam plastic insulating board laminated to interior face.
- B. Materials:
 - 1. Span Rating and Performance Category of Sheathing Layer: Not less than 24/16; 7/16 Performance Category.
 - 2. Edge Configuration: Square finished.
 - 3. Oriented Strand Board: Comply with the following:
 - a. Standard: DOC PS 2.

- b. Binder: Containing no added urea formaldehyde.
- c. Thickness: As shown, if not 7/16 inch.
- 4. Insulating board: Rigid polyisocyanurate foam core with coated glass fiber facers on both sides, and the following characteristics:
 - a. Standard: ASTM C1289 Type II, Class 2, and ICC-ES AC12.
 - b. Thickness: As shown on drawings.
 - c. Nominal Density: 2.0 pcf (32 kg/cu. m).
 - d. Compressive Strength, ASTM D1621: Not less than 20 psi (150 kPa).
 - e. Vapor Permeance, ASTM E96/E96M: Less than 1.0 perm.
- 5. Exterior Facer: Medium-density, phenolic-impregnated polymer-modified sheet material meeting requirements for ASTM D779 Grade D weather-resistive barrier in accordance with ICC AC38 and AC310, with fastener spacing symbols on exterior facer for 16-inch (406 mm) and 24-inch (610 mm) on center spacing, with the following characteristics
 - a. Water Resistance of Coatings, ASTM D2247: Pass 14 day exposure test.
 - b. Moisture Vapor Transmission, ASTM E96: Not less than 12 perms.
 - c. Water Penetration, ASTM E331: Pass at 2.86 lbf/sq. ft. (137 Pa).
 - d. Wind Driven Rain, TAS-100: Pass.
 - e. Accelerated Weathering, ASTM G154: Pass.

2.4 FASTENERS

- A. General: Provide fasteners of size and type indicated that comply with requirements specified and as recommended by manufacturer.
 - 1. For roof and wall sheathing, provide fasteners with hot-dip zinc coating complying with ASTM A 153/A or provide Type 304 stainless steel.
 - 2. Nails, Bradss: ASTM F 1667.
 - 3. Power-Driven Fasteners: NES NER-272 or ICC-ES-1539
 - 4. Wood Screws: ASME B18.6.1.
- B. Fasteners for concrete masonry units, concrete or steel studs:
 - 1. Acceptable product: Hunter Panel SIP SD Fastener.
 - 2. Type: Mechanically fastened star/spider head coated screw, not less than 3/16 inch shank.
 - 3. Coating: Corrosion resistant coated, hot dip galvanized or solid stainless steel.
 - 4. Plates: Only if required by FM.
 - 5. Pre-drilling: Normally not required.
 - 6. Penetration: As recommended by manufacturer for application, normally 1 inch or more.

2.5 SHEATHING JOINT-AND-PENETRATION TREATMENT MATERIALS

- A. Sealant: As recommended by manufacturer, such as: silicone emulsion sealant complying with ASTM C 834, compatible with sheathing tape and sheathing.
- B. Self-Adhering Seam and Flashing Tape: Pressure-sensitive, self-adhering, cold-applied, seam tape consisting of polyolefin film with acrylic adhesive, meeting ICC AC148.
 - 1. Basis-of-Design Product: Huber Engineered Woods; ZIP System Tape.
 - 2. Thickness: 0.012 inch (0.3 mm).
- C. Provide stretch tape to seal around penetrations, windows and doors per manufacturer's instructions.

PART 3 - EXECUTION

3.1 EXECUTION, GENERAL

- A. Comply with the provisions of Section 01 70 00 - including requirements related to:
 - 1. Inspection and examination. Tolerances and measurement.
 - 2. Approvals, inspections and filed quality control.
 - 3. Layout. Adjusting.
 - 4. Cleaning. Protection.

3.2 INSTALLATION, GENERAL

- A. Do not use materials with defects that impair quality of sheathing or pieces that are too small to use with minimum number of joints or optimum joint arrangement. Arrange joints so that pieces do not span between fewer than three support members.
- B. Cut panels at penetrations, edges, and other obstructions of work; fit tightly against abutting construction unless otherwise indicated.
- C. Securely attach to substrate by fastening as indicated, complying with the following:
 - 1. NES NER-272 for power-driven fasteners.
 - 2. Table 2304.9.1, "Fastening Schedule," in ICC's "International Building Code."
 - 3. Table R602.3(1), "Fastener Schedule for Structural Members," and Table R602.3(2), "Alternate Attachments," in ICC's "International Residential Code for One- and Two-Family Dwellings."
- D. Use common wire nails unless otherwise indicated. Select fasteners of size that will not fully penetrate members where opposite side will be exposed to view or will receive finish materials. Make tight connections. Install fasteners without splitting wood.
- E. Coordinate wall and roof sheathing installation with flashing and joint-sealant installation so these materials are installed in sequence and manner that prevent exterior moisture from passing through completed assembly.
 - 1. Air and Moisture Barrier: Coordinate sheathing installation with flashing and joint sealant installation and with adjacent building air and moisture barrier components to provide complete, continuous air and moisture barrier.
- F. Install panels with laminated facer to exterior. Stagger end joints of adjacent panel runs.
- G. Do not bridge building expansion joints; cut and space edges of panels to match spacing of structural support elements.
- H. Coordinate sheathing installation with installation of materials installed over sheathing so sheathing is not exposed to precipitation or left exposed at end of the workday when rain is forecast. Tape polyiso foam edges which may be exposed to sunlight for 60 days or more with compatible waterproof tape.
- I. Apply seam tape at all panel seams, penetrations, and facer defects or cracks to form continuous weathertight surface. Apply tape according to manufacturer's written instructions and requirements of ICC-ES applicable to tape application.

3.3 CLEANING

- A. Clean work under provisions of Section 01 70 00.

END OF SECTION

SECTION 06 17 53

WOOD TRUSSES

PART 1 - GENERAL

1.1 SUMMARY

- A. Provide prefabricated and pre-engineered wood trusses.

1.2 SUBMITTALS

- A. Product Data: Submit manufacturer's product data and installation instructions for each material and product used.
- B. Shop Drawings: Submit shop drawings indicating material characteristics, details of construction, connections, and relationship with adjacent construction.
 - 1. Shop drawings shall be prepared and stamped by a qualified engineer licensed in the jurisdiction of the project.

1.3 QUALITY ASSURANCE

- A. Comply with governing codes and regulations. Provide products of acceptable manufacturers which have been in satisfactory use in similar service for three years. Use experienced installers. Deliver, handle, and store materials in accordance with manufacturer's instructions.
- B. Standards: TPI, Design Specification for Metal Plate Connected Wood Trusses; TPI, Design Specification for Metal Plate Connected Parallel Chord Wood Trusses.
- C. Design Engineering: Registered engineer.

PART 2 - PRODUCTS

2.1 MATERIALS

- A. Wood Trusses:
 - 1. Lumber Standard: PS 20 American Softwood Lumber Standard.
 - 2. Dressing: Dressed four sides.
 - 3. Species and Grade: Manufacturer's option.
 - 4. Moisture Content: Seasoned, 19 percent maximum.
- B. Connectors, Fasteners, and Metal Framing Anchors:
 - 1. Nails, Wire, Brads, and Staples: FS FF-N-105.

2. Power Driven Fasteners: National Evaluation Report NER-272.
3. Wood Screws: ANSI B18.6.1.
4. Lag Bolts: ANSI B18.2.1.
5. Bolts: ASTM A 307, Grade A; ASTM A 563.
6. Metal Framing Anchors: Hot-dip galvanized steel sheet, ASTM A 653, G60.
7. Connectors: Hot-dip galvanized steel sheet, ASTM A 653, G60 on Electrolytic zinc-coated steel sheet, ASTM A 653; ASTM A 591, Coating Class C.

PART 3 - EXECUTION

3.1 INSTALLATION

- A. Comply with recommendations of TPI Design Specifications for Metal Plate Connected Wood Trusses.
- B. Comply with Structural Building Component Association's "Building Component Safety Information: Guide to Good Practice for Handling, Installing, Restraining & Bracing of Metal Plate Connected Wood Trusses."
- C. Install materials and systems in accordance with manufacturer's instructions and approved submittals. Install materials and systems in proper relation with adjacent construction. Coordinate with work of other sections.
- D. Restore damaged components. Clean and protect work from damage.

END OF SECTION 06 17 53

SECTION 06 20 10

CARPENTRY AND MILLWORK

PART 1 - GENERAL

1.01 SUMMARY

- A. Related Documents:
The Drawings and general provisions of the Contract, including General and Supplementary General Conditions, and Division 1 Requirements, apply to the work in this Section.

1.02 SECTION INCLUDES

- A. All labor and materials, equipment and installation of all work required to complete the construction and installation of all work required to this trade as indicated on the drawings and as herein specified.

1.03 RELATED SECTIONS

- A. Section 09 91 00 – Painting
- B. Section 12 32 16 – Plastic Laminate Casework

1.04 REFERENCES

- A. American Plywood Association
- B. American Woodwork Institute

1.05 SUBMITTALS

- A. Submit shop drawings, product data and samples under provisions of Section 01 33 00.

1.06 QUALITY ASSURANCE

- A. Work shall comply with all local and state building and fire codes.
- B. Material and workmanship of all woodwork shall conform to the Premium grade requirements of the AWI Quality Standards.
- C. Rough Carpentry Lumber: Visible grade stamp, of agency certified by National Forest Products Association (NFPA).

1.07 REGULATORY REQUIREMENTS

- A. All materials are to conform to the minimum requirements of the State Building Code or as indicated in this specification, whichever is stronger or stricter.

1.08 DELIVERY, STORAGE AND HANDLING

- A. Deliver, store, protect and handle products to site under provisions of Section 01 60 00.
- B. Protect all materials from weather. Do not store in damp or wet areas. Stack lumber and plywood, and provide air circulation within stacks.

1.09 FIELD MEASUREMENTS

- A. Verify all field dimensions at the site prior to fabrication.

1.10 COORDINATION

- A. Coordinate work with other trades and under provisions of Section 01 31 00.

1.11 SUSTAINABLE BUILDING MATERIAL REQUIREMENTS

- A. All wood products used on this project are to be designated as "FSC-Certified" according to the rules of the Forest Stewardship Council (FSC) (www.fscus.org).

PART 2 - PRODUCTS

2.01 MATERIALS

- A. Framing Lumber
 - 1. Moisture content when delivered to the project shall not exceed 19 percent.
 - 2. Wood studs, blocking, bridging, nailing pieces, shall be Douglas Fir, Coast Region construction grade "J" and "P" or Southern Pine No. 1. All structural load bearing lumber shall be of quality to provide 1200 psi units fiber stress.
 - 3. Mark of treating company certifying type of treatment applied on fire retardant treated and pressure preservative treated lumber.
- B. Plywood shall be of the types and grades listed below:
 - 1. Exposed exterior plywood to be American Plywood Association A-C, Group 1, Exterior, in thickness as noted on the drawings. Where thickness is not indicated, plywood shall be 3/4" thick.
 - 2. Exposed interior plywood to be American Plywood Association A-C, Group 1, Exposure 1, in thickness as noted on the drawings. Where thickness is not indicated, plywood shall be 3/4" thick.
 - 3. Each panel of plywood shall be identified with a stamp as to type, grade and species by the grade trademark of the American Plywood Association. Mark of treating company certifying type of treatment applied on fire retardant treated and pressure preservative treated plywood.
 - 4. All sheathing plywood shall be in accordance with Chapter 23 of the State of Rhode Island Building Code.

- C. Interior and Exterior Woodwork for Paint Finish
 - 1. Quality: Wood shall be free from knots, pitch or sap streaks, molded and executed as detailed and noted on the drawings.
 - 2. Species: Wood shall be clear, kiln-dried close-grained hardwood unless otherwise indicated.

- D. Interior Woodwork for Transparent Finish
 - 1. Quality: Wood shall be free from pitch or sap streaks, molded and executed as detailed and noted on drawings.
 - 2. Species: All wood and plywood shall be red oak unless otherwise indicated.

- E. Wood Treatment
 - 1. Wood preservative used to treat the wood materials shall be alkaline copper quaternary (ACQ).
 - 2. Treat wood materials requiring pressure impregnated preservatives to FS TT-W-571, Table 3.
 - 3. Deliver treated materials cut to required sizes. Minimize field cutting.
 - 4. Re-dry wood after pressure treatment to maximum 19 percent moisture content.
 - 5. Use stainless steel fasteners where installed in pressure treated wood.

- F. Plastic Laminate
 - 1. Manufacturers
 - a. Subject to compliance with requirements of this Specification Section, provide products listed herein from one of the following:
 - 1. Wilsonart Corporation
 - 2. Formica
 - 3. Arborite
 - b. Substitutions: Under provisions of Section 01 60 00.
 - 2. Counter tops and backsplashes:
 - a. Standard High Pressure Decorative Laminate Listed on drawings as PLAM1 and PLAM2.
 - 1. General Purpose Type: Wilsonart Type 107.
 - a. Sheet thickness: 0.048 inch nominal.
 - b. Exceeding performance requirements of NEMA LD 3 current revision Grade HGS.
 - c. Meets the surface burning characteristics in accordance with ASTM E 84; unbonded.
 - b. Durable High Pressure Decorative Laminate Listed on drawings as PLAM3, PLAM4 and PLAM5.
 - 1. Wilsonart "Traceless" Laminate, Type 138.
 - a. Sheet thickness: 0.039 inch nominal
 - b. Meets the surface burning characteristics in accordance with ASTM E 84; unbonded.

3. Laminate on shelving and other surfaces:
 - a. Standard High Pressure Decorative Laminate - Vertical Surface Type: Wilsonart Type 335, having the following physical characteristics:
 1. Sheet thickness: 0.028 inch nominal.
 2. Exceeding performance requirements of NEMA LD 3 current revision Grade VGS and VGP.
 3. Surface burning characteristics in accordance with ASTM E 84; unbonded.
 4. Matte finish, unless otherwise indicated.
 5. Colors as selected by Architect from standard manufacturer's colors and patterns.
 6. Adhesives: As recommended by the manufacturer. Do not use adhesives that contain urea formaldehyde.
- G. Counter Brackets – Surface Mounted
1. Manufacturer: Rakks manufactured by the Rangine Corporation
 2. Surface mounted Rakks models as follows:
 3. Provide the following models and sizes as required unless otherwise noted on drawings:
 - EH-1209: 12" x 9" (12" vertical) on counters between 11" and 13" deep
 - EH-1212: 12" x 12" on counters between 13 1/2" and 18" deep
 - EH-1818: 18" x 18" on counters between 18 1/2" and 25" deep
 - EH-1824: 18" x 24" (18" vertical) on counters between 25 1/2" to 30" deep
 4. Finish to be selected by Architect from manufacturer's standard colors. Provide Off-White.
 5. Fasteners in wall are to match color of bracket.
 6. Provide wood blocking in stud walls as required.
 7. Max distance between brackets to be 32 inches.
Also provide a bracket at the end of countertops that are not attached to a side wall.
 8. Size bracket as required to coordinate with shelf depth as noted on the drawings.
 9. Provide 5/8" dia. rubber grommet option in all vertical legs of each bracket.
- H. Counter Brackets – In-wall Mounted
1. Manufacturer: Rakks manufactured by the Rangine Corporation
 2. Inside wall mount Rakks models as follows:
 3. Provide the following models and sizes as required unless otherwise noted on drawings:
 - EH-1209FM: 12" x 11" (12" vertical) on counters between 11" and 13" deep
 - EH-1212FM: 12" x 14" on counters between 13 1/2" and 18" deep
 - EH-1818FM: 18" x 20" on counters between 18 1/2" and 25" deep
 - EH-1824FM: 18" x 26" (18" vertical) on counters between 25 1/2" to 30" deep
 4. Finish to be selected by Architect from manufacturer's standard colors. Provide Off-White.
 5. Brackets are attached to the side of studs prior to the application of the gypsum board.
 6. Provide wood blocking inside the stud of metal stud walls to provide solid support for the fasteners. Provide through bolts through the wood stud per manufacturer's instructions. Patch gap around opening through gypsum board for a finished installation.
 7. Max distance between brackets to be 32 inches.
Also provide a bracket at the end of countertops that are not attached to a side wall.
 8. Size bracket as required to coordinate with shelf depth as noted on the drawings.
- I. Shelving Brackets and Standards – Adjustable
1. Manufacturer: Knappe & Vogt (K&V)
 2. 187LL series brackets and 87 series standards.
 3. Finish to be selected by Architect from manufacturer's standard colors.
 4. Provide wood blocking in stud walls as required.

5. Max distance between standards to be 32 inches.
 6. Size bracket as required to coordinate with shelf depth as noted on the drawings.
- J. Closet rod and bracket: Manufacturer to be Knappe & Vogt
1. Closet shelf/pole brackets to be Model 1195 with white or cream color finish.
 2. Closet rod to be Model 750-5 heavy duty round steel with chrome finish, 1 5/16 inch outside diameter, 0.075 inch wall thickness.
 3. Wall mount flanges to be Model 764 with chrome finish
 4. Provide matching end cap at all exposed closet rod ends as necessary.
 5. Provide support at maximum 48 inches o.c.
 6. Provide painted 1 x 12 wood shelf full width of closet.
- K. Plastic Countertop Grommets
1. Unless noted otherwise on the drawings all grommets to be Model XG3, 3" Diameter, Flip-Top Grommet Set as Manufactured by Doug Mockett & Company.
 2. Grommet cap and liner set includes liner and cap with cord slot. Cap features Flip-Top tab which closes and covers cord slot when grommet is not in use.
 3. Color selected by Architect from manufacturer's standard colors.
 4. See drawings for quantities and locations.

PART 3 - EXECUTION

3.01 CONSTRUCTION

- A. Rough Carpentry
1. General: Carefully lay out, cut, fit and rout all framing, blocking and other items of carpentry in such a manner as to minimize shrinkage and insure stability. Perform all carpentry work required for building in work of other trades and work to the details indicated and as required by field conditions.
 2. Provide fire retardant treated wood products as shown and as follows:
At exposed or semi-exposed wood in fire rated assemblies and in spaces having limited flame spreads for exposed combustibles. Where blocking is concealed in fire rated assemblies and all areas as required by code.
 3. Includes: Rough carpentry shall consist of the installation of sleepers, blocking, nailers, curb nailers, furring, joists, studding, rafters, stringers, centers, rough flooring, grounds, screeds, and such other items of rough carpentry as may be required for proper construction and to complete the work. Absence of illustration, detail or specification will not relieve the Contractor from responsibility or carrying out the work.
 4. Lumber and other rough work shall be properly framed closely fitted, accurately set to the required lines and levels and rigidly secured in place.
Joists and rough stair stringers shall be set with the crown edge up, and the bottom edges shall be free from pronounced defects.
Leveling of sills, etc., on masonry or concrete shall be done, as required and grouted with cement mortar.
Studs and joists shall be sized to give true surfaces for finish.
Nailing and spiking shall be done in a thorough manner with nails of ample size, spikes larger than 20d being used where practicable.
Special framing or construction, not explicitly shown on drawings or specified, shall be provided as required to complete the work in the best and most workmanlike manner.

5. Mechanical equipment clearances: Members shall be framed to allow for passage of pipes or ducts as required to avoid cutting of structural members. No members shall be cut, notched or bored for the passage of such pipes without permission of the Architect, and all members damaged by cutting shall be reinforced as directed by the Architect.
6. Preservative treated lumber: All wood in direct contact with concrete, masonry, soil or gravel shall be preservative treated wood, ground contact grade with a 40 year warranty. Wood shall be free from large or loose knots, shakes, checks and warp. Apply two coats of same preservative used in original treatment to all sawn or cut surfaces of treated lumber, in accordance with AWPA M4.
Use stainless steel fasteners where installed in the pressure treated wood.
7. Studs: Studs shall be no less than 2"x4", spaced not over 16 inches on center, unless otherwise shown. Studs shall be doubled around all openings. Corners shall be thoroughly spiked together and made solid. All bearing partitions shall be provided with double top and bottom plates. Partitions shall have one row of horizontal bridging for the full width of studding, cut in and securely nailed. Studs shall be framed as shown or required for the proper installation of trim, plumbing, and other work to be concealed. Studding shall be installed for the support of all fixtures and accessories as required.
8. Furring and Grounds: Shall be minimum 1" x 3" strips, as shown on drawings or as required to match the condition, spaced maximum 16" on center and continuous at all vertical edges of framed openings. Furring shall be secured to concrete, brick or masonry units by power driven fasteners. Face of furring and grounds shall form a true, even plane for installation of materials thereon. Species shall be Fir or Southern Pine, at Contractor's option.
9. Roof framing
 - a. Members shall be assembled, fitted and set to exact slopes as shown on the drawings. Tops of rafters shall be brought to a true plane. Ridge members, where shown, shall be straight and true intersections of roof planes of depth equal to the cut on the rafters. Rafters on plates and ridges shall be framed with close joints. Blocking shall be placed between rafters where necessary to form nailers for roof sheathing. Rafters are to be well spiked to wall plates and ridges.
 - b. Provide all required cants, crickets, curbs and other carpentry items required for proper installation of roofing and equipment.
10. Trim
 - a. Trim shall be mitered and jointing shall be tight and formed to conceal shrinkage. All mortise, tongue-and-groove and shiplap joints shall be set in neutral white caulking compound. Interior woodwork shall be back primed and painted before installation.
 - b. Interior trim shall be milled, fabricated and erected as shown on the drawings. All finishes shall be machine-sanded at the mill and sand-papered and primed at the job.
Wood used for trim is to be any close-grained hardwood.
All interior trim including base, chair rails, ceiling mouldings, casings, window stools and aprons shall be of stock designs. All joints shall be made in an approved manner to conceal shrinkage and shall be tight, straight, plumb and level, in perfect alignment and closely fitted. Joints shall be secured with finish nails set for putty stopping. Window and door trim shall be in single lengths. Base shall be in long lengths. Mouldings shall be mitered at corners and coped at angles. These joints shall be made at the mill.

11. Plastic Laminate Countertops and Backsplash/sidesplash
 - a. Countertop in dry areas shall consist of a layer of plastic laminate adhered to 3/4" medium density fiberboard (MDF) with backer sheet.
 - b. Countertop in wet areas shall consist of a layer of plastic laminate adhered to 3/4" water resistant medium density fiberboard (MDF) (Medex or equal) with backer sheet.
 - c. Backsplashes and sidesplashes shall be installed as indicated on drawings.
 - d. Plastic laminate adhesive shall be selected in accordance with manufacturer's recommendations for specific substrate used.
 - e. Front edge and exposed side edges of countertop are to be 3 mm thick PVC unless noted otherwise on drawings.
Top and side exposed edges of backsplashes and sidesplashes are to be 3 mm thick PVC unless noted otherwise on drawings.
The 3 mm PVC is to be solid, high-impact, purified, color-thru, acid resistant, machine-applied with hot melt adhesives, trimmed, length-radiused for uniform appearance, buffed and corner-radiused for consistent design.
Submit sample to be approved by Architect.
 12. Plastic Laminate Shelving where noted on drawings:
Plastic laminate is to be adhered to a MDF substrate, 3/4" thick unless noted otherwise.
Laminate is to be on all six sides.
 13. Medium density fiberboard (MDF) shelving or window sills where noted on drawings are to be 3/4" thick unless noted otherwise and are to be factory primed and then the finish coats field painted in accordance with Section 09 91 00.
Window sills are to be water resistant MDF (Medex or equal).
 14. Temporary Enclosures and Protection: Temporary enclosures of doors, windows and other exterior openings shall be provided when necessary to meet conditions specified. Maintain in good repair and remove when no longer required. Door and window frames shall be protected from traffic and from mortar drippings.
- B. Blocking
1. Blocking layout and size: Continuous and solid, fire retardant 3/4 inch plywood or fire retardant 2x4 or larger where additional support is required.
 2. Provide blocking in addition to any indications on the drawings in locations as follows:
 - a. Millwork attached to walls or ceilings.
 - b. All standing and running trim
 - c. Equipment attached to walls or ceilings.
 - d. At grab bars.
 - e. Toilet Room accessories.
 - f. Handrail brackets.
 - g. Wall hung lavatories.
 - h. At cabinets and casework.
 - i. At shelving and counter brackets.
 - j. Closet rod/shelf brackets.
 - k. At all door wall stops.
 - l. At window shades, blinds or drapes brackets or hardware and FF&E work.
 - m. As required to support light fixtures.
 - n. At exterior items or fixtures mounted or attached where insulating sheathing, or cement, vinyl, PVC, or wood-lapped board siding or trim is used.

3. Attach blocking as follows:
 - a. In metal stud partitions: Screw attach through stud flanges.
 - b. At masonry: With oval head toggle bolts and washers or with epoxy tube and sleeve systems.
 - c. At concrete: With expansion shield bolts.
 - d. At steel: With flat head bolts/nuts or approved power actuated fasteners.

D. Plywood backer panels:

1. Material: APA C-D Plugged Exposure 1 with exterior glue
2. Fire retardant.
3. Coatings: Fire retardant paint, six sides, applied before installation.
4. Coating color: As shown or directed, if not, black.
5. Thickness: As indicated, if not, 3/4 inch.
6. Provide and install fire retardant plywood backer panels for surface mounted electric panel boards, meter mounts, protection cabinets, motor control panels and the like. Boards shall be rigidly built and securely fastened to wood-furred strapping at walls in approved manner. See Electrical Drawings for locations of devices which require mounting on backerboards. Provide plywood backings for Telephone and Protection (Security) panels.

E. Construction Hardware

1. Furnish and install all bolts, nuts, expansion shields, lag screws, toggle bolts, wood screws, nails, flat cap metal nailing discs, staples, power driven anchors and other rough hardware as required.
2. Rough hardware items shall be of appropriate type and proper capacity and size as required for each specific application.
3. All fasteners used on exterior work shall be hot dip galvanized or stainless steel.
4. Concrete and masonry anchors: Where anchors are not included in concrete or masonry construction sections, anchors shall be galvanized machine screws or bolts with standard expansion-shield type concrete anchors, Phillips "Red Head" Masonry Anchors or approved equal, of sizes and types as required.
5. Fasteners used at treated wood: Fasteners meeting manufacturers approval and requirements if not listed use stainless steel.

3.02 CLEANING

- A. Clean work under provisions of 01 70 00.

3.03 PROTECTION OF FINISHED WORK

- A. Protect finished work under provisions of Section 01 70 00.

END OF SECTION

SECTION 06 61 16

SOLID SURFACING MATERIAL

PART 1 - GENERAL

1.01 SECTION INCLUDES

- A. Solid surfacing material application where indicated.

1.02 REFERENCES

- A. ISSFA-2, "Classification And Standards Publication of Solid Surfacing Material".
- B. ANSI Z124-3 for vanities and Z124-6 for kitchen sinks.
- C. NSF Standard 51 for use in both splash and food service areas.
- D. ASTM G21 "Fungal Resistance", no growth.
- E. ASTM G22 "Bacterial Resistance", no growth.
- F. Stain Resistance, ANSI Z124-6-5.2 1997.

1.03 SUBMITTALS

- A. Submit under provisions of Section 01 33 00.
- B. Product Data: Manufacturer's technical literature indicating physical properties and performance criteria for solid surfacing materials and related components.
- C. Shop Drawings: Indicate design parameters, adjacent construction, materials, dimensions, thickness, fabrication details, tolerances, jointing methods, method of support, anchorages, integration with plumbing fixtures and connections, and colors.
- D. Samples: Submit two, 2 inch by 2 inch samples representative of colors, patterns, textures, finishes and edge treatments. Approved samples will be retained as a standard for the work.
- E. Informational Submittals: Submit following packaged separately from other submittals:
 - 1. Maintenance Data: Manufacturer's recommended cleaning and maintenance procedures. Include in project closeout documents.

1.04 RELATED SECTIONS

- A. Prefinished cabinets and casework.

1.05 QUALITY ASSURANCE

- A. Conform to national sanitation foundation, standard #51 requirements.
- B. Design Load: Deflection limited to 1/360.

- C. Fire-Test-Response Characteristics: Provide solid surfacing fabrications with the following surface-burning characteristics as determined by testing identical products per ASTM E 84 by UL 723 or another testing and inspecting agency acceptable to authorities having jurisdiction:
 - 1. Flame-Spread Index: 25 or less.
 - 2. Smoke-Developed Index: 450 or less.

1.06 DELIVERY, STORAGE, AND HANDLING

- A. Deliver, store, handle and protect products to site under provisions of Section 01 60 00.
- B. Store and protect joint adhesive and sealant from freezing or overheating in accordance with manufacturer's instructions.
- C. Provide protective coverings of suitable material. Take special precautions at corners.

1.07 ENVIRONMENTAL REQUIREMENTS

- A. Adhesive and sealant shall be installed in environmental conditions as specified by the manufacturer. Not to be installed below 65 degrees F.

1.08 FIELD MEASUREMENTS

- A. Field verify all dimensions prior to fabrication.

1.09 COORDINATION

- A. Coordinate work under provisions of Section 01 31 00.
- B. Coordinate sizes and locations of plumbing, cut-outs and other related Work specified in other Sections to ensure that interior architectural woodwork can be supported and installed as indicated.

1.10 WARRANTY

- A. Provide 10 year warranty under provisions of Section 01 78 00.

PART 2 - PRODUCTS

2.01 MANUFACTURERS

- A. Everform Solid Surfacing by Formica Corporation
Listed on drawings as SS-3 and SS-4.
(Different standard colors & patterns as selected by the Architect.)
- B. Other acceptable manufacturers offering equivalent products.
 - 1. Corian by the Dupont Co.
- C. Substitutions: Under provisions of Section 01 60 00.

2.02 MATERIALS

- A. Solid Surfacing Materials: Homogeneous solid sheets of filled plastic resin complying with ISSFA-2.
 - 1. Colors and Patterns: As selected by Architect from manufacturer's full range of materials including all price groups and all series.
 - 2. Solid surfacing material is to contain a minimum 10% of combined Pre-consumer and Post-consumer recycled content.
- B. Special Features: Eased edge treatments.
- C. Accessories:
 - 1. Adhesives: For seams and drop edges, Formica Solid Surfacing Seaming Cartridges, 9 ounce; color to blend with sheet material.
 - 2. VOC Limits for Installation Adhesives and Glues: Use installation adhesives that comply with the limits for VOC content when calculated according to 40 CFR 59, Subpart D (EPA Method 24).
- D. Sheets are to be 1/2" unless noted otherwise. Solid surface is to be adhesively joined with no exposed seams.
- E. Silicone sealant to be color coordinated.

2.03 FABRICATION

- A. Assemble work at shop following manufacturer's printed fabrication instructions and deliver to job ready for installation. Manufacture in largest practical pieces for handling and shipping without seams.
 - 1. Fabricate work square and to required lines.
 - 2. Recess and conceal fasteners, connections, and reinforcing.
 - 3. Design construction and installation details to allow for expansion and contraction of materials. Properly frames material with tight, hairline joints held rigidly in place.
 - 4. Provide cut-outs for plumbing fixtures and trim, washroom accessories, appliances, and related items. Confirm lay-out with manufacturer's cut-out templates before beginning work. Round corners of cut-outs and sand edges smooth.
 - 5. Do not exceed manufacturer's recommended unsupported overhang distances.
 - 6. Finish exposed surfaces smooth and polish to low sheen.
 - 7. Radius corners and edges.
- B. Countertops: Horizontal surfaces of 1/2 inch thick (unless noted otherwise), Solid Surfacing, adhesively joined with no exposed seams, edge details as indicated on drawings. If not indicated on drawings the leading edge is to be a Half Bullnose Edge.
- C. Vertical Surfaces: 1/4 inch or 1/2 inch thick Solid Surfacing, adhesively joined with no exposed seams, edge details as indicated.

All cutouts shall be made as required to install sink, faucets, etc. as specified elsewhere.

- D. All countertops shall include a 4" high by 1/2" thick splash where counter abuts walls unless noted otherwise on the drawings. All splash leading edges shall have a radius (eased) edge unless noted otherwise. All connecting corners shall be mitered.

2.04 FINISH

- A. Provide surface with a fine matte finish.
- B. Colors shall be as selected by the Architect from the manufacturer's entire standard selections from the groups noted in the Materials paragraph above.

2.05 QUALITY CONTROL

- A. Solid surfacing material shall meet or exceed the physical properties as tested by the methods listed in Section 1.02 of this specification.

PART 3 - EXECUTION

3.01 INSTALLATION

- A. Components shall be installed as per manufacturer's instructions.
- B. Set items plumb, level, rigid and solidly adhered to substrate.
- C. Prefit items: Adjust supports to make fit. Align joints over support framing.

3.02 CLEANING

- A. Clean work under provisions of Section 01 70 00.
- B. Clean and polish fabrications in accordance with manufacturer's instructions.
- C. Promptly remove excessive mastic and seam adhesive.
- D. Clean tops and splashes in accordance with manufacturer's recommendations.

END OF SECTION

SECTION 06 83 16

FIBERGLASS REINFORCED PLASTIC PANELS

PART 1 - GENERAL

1.01 SECTION INCLUDES

- A. The furnishing and installation of fiberglass reinforced plastic (FRP) wall paneling.

1.02 RELATED SECTIONS

- A. Section 06 20 10 - Carpentry and millwork

1.03 REFERENCES

- A. ASTM E84 Standard Test Method for Surface Burning Characteristics
- B. ASTM D2583 Barcol Hardness
- C. ASTM D256 Izod Impact Strengths (ft #/in)
- D. ASTM D570 Water Absorption (%)
- E. ASTM D5319 Standard Specification for Glass-Fiber Reinforced Polyester Wall and Ceiling Panels.

1.04 SUBMITTALS

- A. Submit under provisions of Section 01 33 00.
- B. Product data: Submit manufacturer's specifications of materials and installation instructions.
- C. Submit two 6" x 12" samples of each type of panel, trim and fastener.
- D. Submit color samples.
- E. Submit test reports
- F. Sustainable Design Submittals:
 - 1. Product Data for Credit EQ 4.1: For adhesives and sealants, include printed statement of VOC content and chemical components.
 - 2. Product Data for Credit EQ 4.4: For laminating adhesive used in factory-laminated plastic panels, indicating that product contains no urea formaldehyde.

1.05 MAINTENANCE DATA

- A. Submit under provisions of Section 01 78 00.
- B. Submit cleaning and maintenance data including procedures for stain removal and cleaning.

1.06 QUALIFICATIONS

- A. Installer: Company specializing in installing the panels with minimum of three years documented experience.

1.07 REGULATORY REQUIREMENTS

- A. Conform to all Federal, State and Local Code requirements.
- B. Conform to the manufacturer's recommendations to achieve the fire resistive ratings as listed by Underwriter's Laboratories.
- C. All building areas designated to be fire rated or as required by State or local codes and scheduled for these panels shall receive a fire resistive system to meet U.L. requirements.

1.08 DELIVERY, STORAGE AND HANDLING

- A. Deliver, store, protect and handle products to site under provisions of Section 01 60 00.
- B. Storage shall be in building, closed to the weather with temperatures ranging from 60°F to 85°F at not more than 70% relative humidity.
- C. Remove foreign matter from face of panel by using a soft cloth or brush to avoid scratching or abrasions.

1.09 ENVIRONMENTAL REQUIREMENTS

- A. Do not install panels when building interior temperature is below 65°F, above 90°F or above 70% relative humidity.
- B. These conditions shall be maintained 48 hours prior to, during and after installation.
- C. Provide ventilation to disperse fumes during application of adhesive as recommended by manufacturer's adhesive instructions.

1.10 FIELD MEASUREMENTS

- A. Verify that field measurements are as indicated on drawings. Any inconsistencies shall be reported to the architect prior to installation.

1.11 SEQUENCING

- A. Installation of panels may commence only after an inspection of all electrical, mechanical and plumbing work has been completed.

1.12 COORDINATION

- A. Coordinate work under provisions of section 01 31 00.

1.13 WARRANTY

- A. Provide a one year warranty under the provisions of Section 01 78 00.

PART 2 - PRODUCTS

2.01 MANUFACTURERS

- A. Subject to compliance with requirements of this Specification Section, provide products listed herein by the following manufacturer:
 - 1. Basis of Design: Marlite Inc.

- B. Other acceptable manufacturers offering equivalent products.
 - 1. NUDO Products Inc.
 - 2. Crane Composites
- C. Substitutions under provisions of Section 01 60 00.

2.02 MATERIALS

- A. Marlite FRP: Class A fire rating
 - 1. Surface texture to be Pebbled.
 - 2. Fire Rating: Marlite FRP is to have a Class A (I) Fire Rating per ASTM E84 latest version.
 - 3. Size: 4' x 8' x 3/32" (.090")
 - 4. Rivets: Provide rivets in coordinating colors.
 - 5. Color as selected by Architect from manufacturer's standard colors.
 - 6. Performance Properties
 - a. Meets USDA/FSIS Requirements.
 - b. Barcol Hardness (scratch resistance) - ASTM D2583: 35 (higher is better)
 - c. Izod Impact strength – ASTM D256: 7.2 foot pounds per inch (higher is better)
 - d. Water Absorption – ASTM D570: 0.72 percent (lower is better)
 - e. Meets the following standards:
 - 1. ASTM D5319 Standard Specification for Glass-Fiber Reinforced Polyester Wall and Ceiling Panels
 - 2. ASTM D968-05 Standard Test Methods for Abrasion Resistance of Organic Coatings by Falling Abrasive.
 - 3. ASTM D3002 - 07 Standard Guide for Evaluation of Coatings Applied to Plastics
 - 4. NEMA LD-2000 Sec. 3.4 Cleanability/Stain Resistance
 - 7. A means of frontside identification and confirmation of meeting Class I (A) interior finish requirements after installation and while in service (without labels), embossed FXI only.
- B. Accessories
 - 1. Provide one-piece, PVC inside and outside corner moldings, division bars at joints and edge trim as required for installation of wall panels. Color to coordinate with panels and be integral throughout.
 - 2. Adhesive as recommended by panel manufacturer and meets ASTM Specification C557.
 - 3. Silicone sealant as recommended by panel manufacturer. Color to match panels and trim.

PART 3 - EXECUTION

3.01 EXAMINATION

- A. Verify that all substrates receiving the panels are acceptable for product installation and are in proper condition and dry. Panels must be applied over a smooth, solid, flat, clean sub-wall.

3.02 PROTECTION

- A. Protect existing elements surrounding the work of this section from damage or disfigurement.

3.03 CONDITIONING

- A. Panel packages are to be opened and allowed to acclimate for 48 hours prior to installation. The building is to be weather tight with HVAC operational and conditioned to final use ambient humidity and temperature. Room temperature should be approximately 65° F or above before beginning installation.

3.04 INSTALLATION

- A. Install all panels and trim in accordance with the manufacturer's installation instructions.
- B. Adhere and mechanically attach with rivets all panels to the wall in accordance with the manufacturer's instructions.
- C. NOTE: All moldings must provide for a minimum 1/8 inch of panel expansion at joints and edges, to insure proper installation.

3.05 CLEANING

- A. Clean under provisions of Section 01 70 00.
- B. Repair or replace products that have been installed and are damaged.
- C. Clean installed products in accordance with manufacturer's instructions.

END OF SECTION

SECTION 07 11 13

BITUMINOUS DAMPPROOFING

PART 1 - GENERAL

1.01 WORK INCLUDED

- A. Clean, patch and prepare surfaces to receive dampproofing specified herein.
- B. Provide dampproofing at interior wythe of concrete masonry units at cavity walls, perimeter of elevator pit foundation walls, and exterior of concrete foundations with basements below grade.

1.02 SUBMITTALS

- A. Submit product data and samples in accordance with Section 01 33 00.
- B. Submit manufacturer's surface preparation and installation instructions.

1.03 ENVIRONMENTAL REQUIREMENTS

- A. Do not apply dampproofing on damp or frozen surfaces.
- B. Ensure temperatures are maintained at a minimum of 40 degrees F for 24 hours before application and continuously until dampproofing has cured.

PART 2 - PRODUCTS

2.01 ACCEPTABLE MANUFACTURERS

- A. Dampproofing: BASF Corporation– Masterseal 614
- B. Other acceptable manufacturers offering equivalent products.
 - 1. Karnak 920AF Fibered Emulsion Mastic
- C. Substitutions: Under provisions of Section 01 60 00.

2.02 MATERIALS

- A. Dampproofing System: Heavy Bodied, non-sag coating reinforced with long fibers; trowel application, waterborne solvent.

PART 3 - EXECUTION

3.01 SURFACE PREPARATION FOR DAMPPROOFING

- A. Clean and prepare surface to receive dampproofing in accordance with manufacturer's recommendations.

- B. Ensure surfaces are firm and free from frost, loose particles, cracks, pits, rough projections, grease, oil and other foreign matter detrimental to adhesion and monolithic application.

3.02 APPLICATION OF DAMPPROOFING

- A. Apply with brush or trowel in one coat, over dry, cured surface, to a dry film thickness of 1/16 inch.
- B. Protect adjacent surfaces from staining or migrating of mastic.
- C. Cover all applied dampproofing with a protection board a minimum of 1/8 inch thick. Board material is to be compatible with the dampproofing.
- D. Carefully backfill against board to prevent penetration of the board and dampproofing.

END OF SECTION

SECTION 07 21 01

GRADE LEVEL INSULATION COVER SHEET

PART 1 – GENERAL

1.01 SUMMARY

- A. Related Documents:
The Drawings and general provisions of the Contract, including General and Supplementary General Conditions, and Division 1 Requirements, apply to the work in this Section.

1.2 SECTION INCLUDES

- A. Section Includes, without limitation, providing:
 - 1. Grade level insulation protection cover sheet.
- B. Extent, without limitation, includes: Protection for foundation and wall insulation exposed at grade level.

1.3 RELATED WORK

- A. Related Sections, without limitation, include:
 - 1. Section 07 21 13 – Board Insulation

1.4 SYSTEM DESCRIPTION

- A. Fiberglass reinforced plastic (FRP) barrier providing protection for insulation exposed at grade level.

1.5 SUBMITTALS

- A. Submit manufacturer's product data and installation instructions under provisions of Section 01 33 00.
 - 1. Product Data: Manufacturer's literature including installation instructions, use restrictions and limitations.

1.6 QUALITY ASSURANCE

- A. Provide products of acceptable manufacturers which have been in satisfactory use in similar service for 5 years. Use experienced installers. Deliver, handle, and store materials in accordance with manufacturer's instructions.

1.7 WARRANTY

- A. Warranty: Provide manufacturer's standard 10 year warranty.

PART 2 - PRODUCTS

2.1 MANUFACTURER

- A. Acceptable manufacturers and fabricators, subject to compliance with requirements, include:
 - 1. Nudo Inc.
 - 2. Substitutions: Under provisions of Section 01 60 00.
- B. Basis of design: Nudo Inc.;. "GroundBreaker".

2.2 MATERIALS

- A. Sheet or roll fiber reinforced plastic as follows:
 - 1. Sheet lengths: Available in 50 foot rolls.
 - 2. Widths: Available in 12, 24, and 48 inch heights.
 - 3. Thickness: 0.060 inch.
- B. Characteristics:
 - 1. UV light resistant.
 - 2. Stain, odor and moisture resistant.
 - 3. Shatter resistant.
 - 4. Color: Selected by Architect from Manufacturer's standard colors.
- C. Accessories: Provide manufacturer recommended components, fasteners, adhesives and trim; where exposed provide matching color to sheet product.

PART 3 - EXECUTION

3.1 GENERAL

- A. Install materials and systems in accordance with manufacturer's instructions, limitations and restrictions and approved submittals. Install materials and systems in proper relation with adjacent construction and with uniform appearance. Coordinate with work of other sections.
- B. Examination: Verify that field conditions are acceptable and are ready to receive work.
 - 1. Level or ensure that insulation to receive sheet protection are plumb, plane and free to irregularities that will telegraph through installed surfaces.
 - 2. Ensure insulation is fully attached or bonded to wall substrates. Correct loose or unsound installations.
- C. Preparation: Plane, shave and prepare exposed insulation surfaces.

3.2 INSTALLATION

- A. Install components plumb and level, accurately fitted, free from distortion or defects, and as follows:
 - 1. Install protection sheet as shown, if not as given below.
 - 2. Anchor, fasten or adhere assemblies securely to insulation using products that

will not damage or dissolve insulation. Use only solvent free adhesives with a track record of durability to exterior conditions.

3. Separate dissimilar materials with bushings, gaskets, grommets, washers or coatings where required to prevent electrolytic corrosion.
4. Use manufacturer's recommended components and hardware unless otherwise shown.

END OF SECTION

THIS PAGE INTENTIONALLY LEFT BLANK

SECTION 07 21 13

BOARD INSULATION

PART 1 - GENERAL

1.01 WORK INCLUDED

- A. Board insulation at cavity wall construction, perimeter foundation wall, and underside of floor slabs.

1.02 REFERENCES

- A. ASTM C578 - Physical properties of Polystyrene.

1.03 SYSTEM DESCRIPTION

- A. Materials of this Section shall provide a continuous thermal barrier at building enclosure elements.

1.04 SUBMITTALS

- A. Submit manufacturer's installation instructions under provisions of Section 01 33 00.
- B. Sustainable Building Material Submittal:
 - 1. For products having recycled content, documentation indicating percentages by weight of postconsumer and preconsumer recycled content.
 - a. Include statement indicating costs for each product having recycled content.
 - 2. Identify each regional material along with the location of its harvest, extraction, or manufacture.

PART 2 - PRODUCTS

2.01 ACCEPTABLE INSULATION MANUFACTURERS

- A. Subject to compliance with requirements of this Specification Section, provide products listed herein from one of the following:
 - 1. Dow Chemical Co
 - 2. Owens Corning
 - 3. DiversiFoam

- B. Basis of Design: Styrofoam Brand by Dow Chemical Co

- C. Substitutions: Under provisions of Section 01 60 00.

2.02 INSULATION MATERIALS

- A. Insulation for masonry veneer/metal stud backup cavity wall shall be Styrofoam Cavitymate: rigid closed cell extruded polystyrene. Thickness to be 1 1/2" with a thermal resistance R-Value of 7.5. (Unless noted otherwise on the drawings.)
Comply with ASTM C 578, Type IV, density 1.6 lb/cu. Ft. min., minimum compressive strength of 25 psi per ASTM D 1621.

Water absorption: Max. 0.1% by volume (ASTM C 272)
Surface burning characteristics: Flame spread=5, Smoke developed=165

- B. Insulation for masonry veneer/masonry backup cavity wall shall be Styrofoam Cavitymate Ultra: rigid closed cell extruded polystyrene. Thickness to be 2.18" with a thermal resistance R-Value of 12. (Unless noted otherwise on the drawings.)
Comply with ASTM C 578, Type IV, density 1.6 lb/cu. Ft. min., minimum compressive strength of 25 psi per ASTM D 1621.
Water absorption: Max. 0.1% by volume (ASTM C 272)
Surface burning characteristics: Flame spread=5, Smoke developed=165
- B. Insulation for perimeter and under slab shall be Styrofoam Brand Square Edge: extruded cellular polystyrene; square edges. Shall meet ASTM C578, Type IV requirements. Compressive strength is a minimum of 25 psi per ASTM D 1621.
Thickness to be 3" with an R-Value of 15, unless noted otherwise on the drawings.
Provide 4" with an R-Value of 20 where noted under the concrete slab.
- C. Insulation between concrete slab and foundation wall shall be Square Edge, extruded cellular polystyrene with square edges and meet ASTM C578 requirements. Starting from the top of the concrete slab, the thickness is to be 0.75" with an R-Value of 3.75 then approximately halfway down the slab the insulation is to taper out at a 45 degree angle. The exposed rigid insulation is to have a top surface approximately 1/8" below the surface of the concrete slab and be sealed over with caulk.
- D. Insulation for furred-out gypboard against concrete block exterior walls shall be Styrofoam Square Edge: extruded cellular polystyrene; square edges. Thickness to be 2.5" with an R-Value of 12.5, (Unless noted otherwise on the drawings.). Comply with ASTM C 578, Type IV, compressive resistance 25 psi (ASTM D 1621).
Water absorption: Max. 0.1% by volume (ASTM C 272)
Surface burning characteristics: Flame spread=5, Smoke developed=165

2.03 ADHESIVE MATERIALS

- A. Adhesive: Type as recommended by insulation manufacturer.
1. Acceptable manufacturer's products:
 - a. ChemRex, Inc. "Contech Brands PL300 Foam Board Adhesive".
 - b. ChemRex, Inc. "Contech Brands Premium Foam Board Adhesive".
 - c. Dacar Products, Inc. "Foamgrab PS".

2.04 SPRAY FOAM GAP INSULATION:

- A. Manufacturer
1. Subject to compliance with requirements of this Specification Section, provide products listed herein from one of the following:
 - a. Dow Chemical Co
 - b. Hilti
 - c. Todol
 2. Basis of Design: Dow Great Stuff Pro Gaps & Cracks Insulating Foam Sealant.

3. Substitutions: Under provisions of Section 01 60 00.
- B. Material: Sprayed-in-place expanding urethane foam with the following characteristics:
 1. Materials: One-component, water-cure closed cell polyurethane containing no urea-formaldehyde and no CFCs ; maximum 100% expansion.
 2. Thermal Performance: Approximately R6 per inch.
 3. Burn Characteristics: ASTM E 84, flame spread less than 25, smoke development less than 210, fuel contribution 0.
 4. Water Absorption: Hydrophobic.
 5. Closed-Cell Formulation: 80% per ASTM D 2856.
 6. Expansion rate: As recommended by manufacturer for application:
 7. Must be approved by the manufacturer to be compatible with the adjacent board insulation.

PART 3 - EXECUTION

3.01 PREPARATION

- A. Verify substrate and adjacent materials and insulation boards are dry and ready to receive insulation and adhesive.
- B. Verify substrate surface is flat, free of fins, irregularities and materials that will impede adhesive bond.
- C. Verify insulation boards are unbroken, free of damage.

3.02 INSTALLATION - FOUNDATION PERIMETER

- A. Apply adhesive in 2" diameter spot applications 12" o.c. in accordance with manufacturer's recommendations.
- B. Install boards on foundation perimeter, vertically. Place boards in a method to maximize contact bedding. Stagger end joints. Butt edges and ends tight to adjacent board and to protrusions.

3.03 INSTALLATION - UNDER CONCRETE SLABS

- A. Place insulation under slabs on grade after base for slab has been compacted.
- B. Prevent insulation from being displaced or damaged while placing vapor barrier and installing concrete slab.

3.04 INSTALLATION - CAVITY WALLS

- A. Apply adhesive in 2" diameter spot applications 12" o.c. both ways in accordance with manufacturer's recommendations.
- B. Install boards horizontally between wall reinforcement.

- C. Place boards in a method to maximize contact bedding. Stagger end joints, except at line of control joints. Butt edges and ends tight to adjacent board and to protrusions.
- D. Butt boards tight against each other to provide a monolithic plane of insulation with minimal gaps or openings.
- E. Fill all cracks and open gaps in and around board insulation with Dow Great Stuff Pro Gaps & Cracks Insulating Foam Sealant (or equal).
- F. Do not span control joints.

3.05 INSTALLATION – FURRED-OUT WALLS

- A. Verify that masonry joints are struck flush and remove concrete fins and mortar projections that will interfere with placement of the insulation boards.
- B. Apply adhesive in 2” diameter spot applications 12” o.c. both ways in accordance with manufacturer's recommendations. Butt tight against the studs, ceiling/deck and floor. Fill all gaps or voids in the insulation.
- C. Install boards vertically between studs or furring.

3.06 CLEANING

- A. Clean work under provisions of Section 01 70 00.

END OF SECTION

SECTION 07 21 19

FOAMED-IN-PLACE INSULATION

PART 1 - GENERAL

1.1 SUMMARY

- A. Related Documents: Drawings and general provisions of the Contract, including General and Supplementary Conditions and Division 1 Specification Sections, apply to this Section.

1.2 SECTION INCLUDES

- A. Provide and install a closed-cell Spray Foam Insulation System consisting of spray foam insulation applied as the base layer on specified substrates and installation of a top layer of intumescent spray foam insulation or coating as the exposed surface.

1.3 REFERENCES

- A. ASTM C518-04 Standard Test Method for Steady-State Thermal Transmission Properties by Means of the Heat Flow Meter
- B. ASTM D 1621-04a Standard Test Method for Compressive Properties of Rigid Cellular Plastics
- C. ASTM D 1622-03 Standard Test Method for Apparent Density of Rigid Cellular Plastics
- D. ASTM D 1623-03 Standard Test Method for Tensile and Tensile Adhesion Properties for Rigid Cellular Plastics
- E. ASTM D 6226-05 Standard Test Method for Open Cell Content of Rigid Cellular Plastics
- F. ASTM E 283-04 Standard Test Method for Determining Rate of Air Leakage
- G. ASTM E 84-08 Standard Test Method for Surface Burning Characteristics of Building Materials
- H. ASTM E 96-05 Standard Test Method for Water Vapor Transmission of Materials
- I. UL 1715 - 97 Fire Test of Interior Finish Material

1.4 SUBMITTALS

- A. Submit under provisions of Section 01 33 00.
- B. Qualifications:
 - 1. Applicator shall be a designated authorized applicator by the manufacturer and their certificate of such shall be submitted to the Architect.
- C. Products:
 - 1. Manufacturer's technical data sheets.

2. Manufacturer's installation instructions.
3. Product Safety Data Sheets (SDS).
4. Evaluation Reports: Issued by an organization accredited by International Accreditation Services, Inc. (a subsidiary of ICC) indicating the products have a flame spread index ≤ 25 , smoke developed index ≤ 450 and complies with all acceptance criteria of the UL 1715, UL 1040, FM 4880 or NFPA 286 large-scale fire test standards when tested without thermal barriers, ignition barriers or any other fireprotective surface(s).
5. Field quality control procedures to be utilized by Applicator to assure proper installation of the products.
6. Submit an ICC-ES Evaluation Report indicating insulation/intumescent system is code compliant.
7. Shop drawings on sheet metal, accessories or other fabricated items, if required.
8. Samples: Submit samples (3" x 3") of each material specified.

1.5 MATERIALS DELIVERY AND STORAGE

- A. Deliver, store and handle products under provisions of Section 01 60 00.
- B. Materials shall be delivered in the manufacturer's original, tightly sealed containers, labeled with the manufacturer's name, product identification, date of manufacture, lot number(s) and fire ratings issued by an accredited inspection agency.
- C. Containers shall be stored out of the weather, direct sun and in compliance with manufacturer's recommendations.

1.6 PROJECT CONDITIONS

- A. Temperature and field conditions: Install products within range of ambient air and substrate temperatures recommended by manufacturer. Do not apply products when substrate has surface moisture or has been contaminated by condensation, rain, mist, fog or snow. It is recommended that spray foam application not be done within 5 degrees F of the dew point.

PART 2 - PRODUCTS

2.1 MANUFACTURERS

- A. Manufacturers: Subject to compliance with requirements, provide products by one of the following:
 1. Demilic Heatlok Insulation with Demilec Blazelok coating
 2. Johns Manville Corbond III with Fireshell Coating
 3. Preferred Solutions, Inc., Staycell 302 with Staycell One Step 255 intumescent coating
- B. Basis of Design: Preferred Solutions, Inc., Cleveland, OH
- C. Substitutions: Under provisions of Section 01 60 00.

2.2 INSULATION AND INTUMESCENT COATING

- A. Staycell® 302 spray polyurethane foam insulation:
 1. Manufacturer: Preferred Solutions, Inc., Cleveland, OH
 2. Thermal Resistance/Insulation Value (ASTM C-518): R-7.0 per inch

3. Compressive Strength (ASTM D-1621): 41 psi
4. Nominal Density (ASTM D-1622): 2.0 pcf
5. Tensile Strength (ASTM D-1623): 58 psi
6. Closed Cell Content (ASTM D-6226): >96%
7. Air Leakage (ASTM E-283): 0.0010 cfm/ft²@ 1 inch
8. Water Vapor Permeance (ASTM E-96):
1.49 perms @ 1"
.92 perms @ 1.5"
.77 perms @ 2"
9. Fire Ratings:
ASTM E-84 (tested at 4 inch thickness):
Flame spread index: <25
Smoke developed index: <450

B. Staycell ONE STEP[®]255 intumescent spray polyurethane foam insulation:

1. Manufacturer: Preferred Solutions, Inc., Cleveland, OH
2. Thermal Resistance/Insulation Value (ASTM C-518): R-4.6 per inch
3. Compressive Strength (ASTM D-1621): 22 psi
4. Density (ASTM D-1622): 2.0 pcf
5. Tensile Strength (ASTM D-1623): 28 psi
6. Closed Cell Content (ASTM D-6226): 90%
7. Air Leakage (ASTM E-283): .0014 cfm/ft²@ 1.25"
8. Water Vapor Permeance (ASTM E-96): .99 perms @ 2.4 inches
9. Fire Ratings:
ASTM E-84 (tested at 4 inch thickness):
Flame spread index: 25
Smoke developed index: 400
Passes UL 1715 large-scale, enclosed-room fire test standard when tested exposed without thermal barriers, ignition barriers or any other fire protective surface(s).

2.3 AUXILIARY MATERIALS

- A. Transition membranes for joints and transitions
 1. AIR-SHIELD or AIR-SHIELD LT by W.R. Meadows, Inc.
 2. Blueskin SA or Blueskin SA LT by Henry Corporation
 3. CCW 705 or CCW 705 LT by Carlisle Coatings and Waterproofing
- B. Primers to prepare substrates for receipt of transition membranes
 1. MEL-PRIME Adhesive or MEL-PRIME W/B by W.R. Meadows, Inc.
 2. Blueskin Adhesive or Blueskin LVC Adhesive by Henry Corporation
 3. CCW-702 WD or CCW-702 LV by Carlisle Coatings and Waterproofing
- C. Foam stop angle: Plastic angle used for foam stop at terminations and transitions
 1. Jam-Ex extruded plastic angle or equal made by Exo-Tec Manufacturing, Inc.
- D. Single-component sealant to bond plastic angle to substrate
 1. Dow 795 silicone building sealant, Dow Corning Corporation
 2. Sikaflex 1A polyurethane sealant, Sika Sarnafil Corporation
 3. Dymonic FC polyurethane sealant, Tremco Corporation

- E. Portable SPF application units for sealing around windows, doors and penetrations
 - 1. Versi-Foam by RHH, Inc.
 - 2. Froth-Pak, Dow Chemical Company
 - 3. Filler Foam by Hilti, Inc.
 - 4. Touch n' Foam by Convenience Products, Inc.

PART 3 – EXECUTION

3.1 EXAMINATION

- A. Examine substrates, areas, and conditions over which the spray polyurethane foam insulation and air barrier will be installed for compliance with requirements.
- B. Verify that surfaces and conditions are suitable prior to commencing work of this section. Do not proceed with installation until unsatisfactory conditions have been corrected.
- C. Ensure items such as hangers for piping and ductwork are installed before work begins.

3.2 SURFACE PREPARATION

- A. Clean, prepare and treat substrate according to manufacturer's written instructions. Provide clean, dust-free and dry substrate for spray polyurethane foam application.
- B. Ensure installed transition membranes and foam stop angles are fully adhered to all applicable surfaces and are capable of receiving spray polyurethane foam.

3.3 PROTECTION

- A. Mask and cover adjacent areas to protect from over spray.
- B. Ensure any required foam stop or back up material are in place to prevent over-spray.
- C. Seal off existing ventilation equipment and ductwork.
- D. Erect barriers, isolate area and post warning signs to advise non-protected personnel to avoid the spray area.

3.4 APPLICATION OF SPRAYED POLYURETHANE FOAM

- A. Spray-application of spray polyurethane foam shall be installed in accordance with manufacturer's written instructions.
- B. Apply only when surfaces and environmental conditions are within limits prescribed by the material manufacturer.
- C. Apply in consecutive passes as recommended by manufacturer to thickness as indicated on drawings and to achieve the specified R-Value.
- D. Staycell[®] HYBRID System:
The Staycell[®] HYBRID System (comprised of the Staycell[®] 302 base layer sprayed at the required thickness.
Where the base layer of insulation is exposed, it is to be covered by the Staycell ONE STEP[®] 255 top layer sprayed at a nominal 1/2 inch thickness onto the base layer surface.
Total spray foam insulation R-value to be as noted on the drawings.
- E. Do not install spray polyurethane foam within 3 inches of heat emitting devices such as light fixtures and chimneys.
- G. Remove masking materials and overspray from adjacent areas after the foam surface has hardened. Ensure cleaning methods do not damage work performed by other sections.
- H. Trim as required any excess thickness that would interfere with the installation of the interior finish (steel framing, gypsum board, etc.) by other trades.

- I. Clean and restore surfaces soiled or damaged by Work of the section.
- J. Do not permit adjacent Work to be damaged by Work of this section. Damage to work of this section caused by other trades shall be repaired at the expense of the subcontractor causing the damage.

3.5 FIELD QUALITY CONTROL

- A. Daily records: The applicator shall keep daily records as to the square feet of surface sprayed each day, quantities of all materials used and thickness tests performed. One thickness test shall be conducted on every 500 square feet of covered surface. Such records shall be provided upon request.
- B. Installed product evaluation: In addition to verifying the thickness of all installed products, the following characteristics shall also be provided:
 - 1. The cellular structure shall be uniform and not be soft or spongy.
 - 2. The foam shall not have areas with hard or brittle sections or improperly proportioned materials.

3.6 SAFETY REQUIREMENTS

- A. Applicator shall comply with all provisions of MSDS sheets for the product.
- B. Ventilation shall be provided to assure fresh air is brought into the area being sprayed. Air shall be exhausted to the outside of the building by utilizing existing fans or by supplemental ventilation.
- C. Disposal of waste materials and containers shall comply with federal, state and local regulations.

3.7 CLEAN-UP

- A. At the completion of the project, applicator shall clean up and remove from the site all material containers, waste materials and debris.

END OF SECTION

THIS PAGE INTENTIONALLY LEFT BLANK

SECTION 07 26 16

UNDER-SLAB VAPOR BARRIER

PART 1 – GENERAL

1.01 SUMMARY

- A. Related Documents:
The Drawings and general provisions of the Contract, including General and Supplementary General Conditions, and Division 1 Requirements, apply to the work in this Section.
- B. Products Supplied Under This Section
 - 1. Vapor Barrier, seam tape, pipe boots, detail strip for installation under concrete slabs.

1.02 RELATED SECTIONS

- A. Division 3 - Concrete Construction

1.03 REFERENCES

- A. American Society for Testing and Materials (ASTM)
 - 1. ASTM E 1745 Standard Specification for Plastic Water Vapor Retarders Used in Contact with Soil or Granular Fill Under Concrete Slabs
 - 2. ASTM E 154 Standard Test Methods for Water Vapor Retarders Used in Contact with Earth Under Concrete Slabs
 - 3. ASTM E 1643 Standard Practice for Installation of Water Vapor Retarders Used in Contact with Earth or Granular Fill Under Concrete Slabs
- B. American Concrete Institute (ACI)
 - 1. ACI 302.2R-06: Guide for Concrete Slabs that Receive Moisture-Sensitive Flooring Materials.
 - 2. ACI 302.1R-15: Guide to Concrete Floor and Slab Construction.

1.04 SUBMITTALS

- A. Submit under provisions of Section 01 33 00.
- B. Quality Control / Assurance
 - 1. Summary of test results: ASTM E1745.
 - 2. All mandatory ASTM E1745 testing must be performed on a single production roll per ASTM E1745 Section 8.1.
 - 3. Manufacturer's samples and literature.
 - 4. Manufacturer's installation instructions for placement, seaming, penetration prevention and repair, and perimeter seal per ASTM E1643.
 - 5. Contact vapor barrier manufacturer to schedule a pre-construction meeting and to coordinate a review, in-person or digital, of the vapor barrier installation.
 - 6. Vapor barrier manufacturer must warrant in writing (a) compliance with the designated ASTM E1745 classification, and (b) no manufacturing defects in the product for, at least, the Life of the Building.

1.05 COORDINATION

- A. Contact vapor barrier manufacturer to schedule a pre-construction meeting and to coordinate a review, in-person or digital, of the vapor barrier installation.
Kayla Cataldo, Northeast Regional Manager | Stego Industries | kaylacataldo@stegoindustries.com
Cell: (617) 605-4590

1.06 WARRANTY

- A. Provide compliance with the designated ASTM E1745 classification.
- B. No manufacturing defects in the product for, at least, the Life of the Building.

PART 2 – PRODUCTS

2.01 MANUFACTURERS

- A. Subject to compliance with requirements of this Specification Section, provide products listed herein from one of the following:
 - a. Basis of Design: Stego Wrap 15 mil Vapor Barrier by Stego Industries LLC
 - b. Approved Alternate: Vaporguard by Reef Industries, Inc.
 - c. Approved Alternate: VaporFlex 15mil by Layfield Construction Products
- B. No additional substitutions allowed.

2.02 MATERIALS

- A. 15 mil Vapor Barrier:
Extremely low permeance vapor barrier.
 - 1. Vapor Barrier must have the following qualities
 - a. Thickness of Barrier (plastic) ACI 302.1R Not less than 15 mils
 - b. Water Vapor Barrier ASTM E-1745 Meets or exceeds Class A
 - c. Water Vapor Permeance Maintain permeance of less than 0.01 Perms [grains/(ft² · hr · inHg)] as tested in accordance with mandatory conditioning tests per ASTM E1745 Section 7.1 (7.1.1-7.1.5).
 - d. Water Vapor Transmission Rate ASTM F 1249 0.0036
 - e. Puncture Resistance ASTM D 1709 2266 grams
 - f. Tensile Strength ASTM D 882 70.6 lbf/in

2.03 ACCESSORIES

- A. Seams:
 - 1. Stego Tape
- B. Sealing Penetrations of Vapor barrier:
 - 1. Stego Mastic
 - 2. Stego Tape

- C. Perimeter/terminated edge seal:
 - 1. Stego Crete Claw (textured tape)
 - 2. Stego Term Bar
 - 3. StegoTack Tape (double-sided sealant tape)
 - 4. One-sided seaming tape is not a recommended method of sealing at the terminated edge.

- D. Penetration Prevention:
 - 1. Beast Foot by Stego Industries LLC
 - 2. Beast Form Stake by Stego Industries LLC

- E. Vapor Barrier-Safe Hand Screed System
 - 1. Beast Screed by Stego Industries, LLC

PART 3 – EXECUTION

3.01 PREPARATION

- A. Ensure that subsoil is approved by architect
 - 1. Level and tamp or roll aggregate, sand or tamped earth base, compacted.

- B. Contractor shall use a screeding system that does not puncture the vapor barrier.

3.02 INSTALLATION

- A. Install Vapor Barrier:
 - 1. Installation shall be in accordance with manufacturer's instructions and ASTM E 1643.
 - a. Install a vapor barrier as specified herein under all concrete slabs-on-grade and other locations as noted in the Construction Documents.
 - b. Unroll vapor barrier with the longest dimension parallel with the direction of the concrete placement and face laps away from the expected direction of the placement whenever possible.
 - c. Extend vapor barrier to the perimeter of the slab. If practicable, terminate it at the top of the slab, otherwise (a) at a point acceptable to the structural engineer or (b) where obstructed by impediments, such as dowels, water stops, or any other site condition requiring early termination of the vapor barrier. At the point of termination, seal vapor barrier to the foundation wall, grade beam or slab itself.
 - 1. Seal vapor barrier to the entire perimeter wall or footing/grade beam with manufacturer's double-sided tape, or both termination bar and double-sided tape, per manufacturer's instructions. Ensure the concrete is clean and dry prior to adhering tape.
 - d. Overlap joints 6 inches and seal with manufacturer's seam tape.
 - e. Apply sealing accessories to a clean and dry vapor barrier.
 - f. Seal all penetrations (including pipes) with manufacturer's pipe boot per manufacturer's instructions.
 - g. Repair damaged areas with vapor barrier material of similar (or better) permeance, puncture and tensile.
 - h. For interior forming applications, avoid the use of non-permanent stakes driven through vapor barrier. Use Beast Form Stake and Beast Foot (or equals) as a vapor

barrier-safe forming system. Ensure Beast Foot's peel-and-stick adhesive base is fully adhered to the vapor barrier.

- i. For a vapor barrier-safe, fixed-elevation concrete screeding application, install Beast Screed (or equal) per manufacturer's instructions prior to placing concrete.

3.03 CLEANING

- A. Clean under provisions of Section 01 70 00.

END OF SECTION

SECTION 07 27 19

AIR INFILTRATION BARRIER

PART 1 - GENERAL

1.01 SUMMARY

- A. Related Documents:
The Drawings and general provisions of the Contract, including General and Supplementary General Conditions, and Division 1 Requirements, apply to the work in this Section.

1.02 WORK INCLUDED

- A. Air infiltration barrier (weather barrier). Single-layer weather barrier, including flashing and sealing of penetrations and seams.

1.03 RELATED WORK

- A. Section 06 16 15 - Composite Nail Base Insulating Sheathing
- B. Section 09 21 16 – Steel framed drywall systems

1.04 REFERENCES

- A. ASTM D-117 – Tear Resistance
- B. ASTM D-882 – Breaking Strength
- C. ASTM E-84-97a – Surface Burning Characteristics
- D. ASTM E-96 Method B – Water Vapor Transmission
- E. ASTM E-1677 – Air Penetration
- F. AATCC-127 – Water Penetration Resistance

1.05 SYSTEM DESCRIPTION

- A. Materials of this Section shall provide a continuous air infiltration barrier at building enclosure elements.

1.06 SCHEDULING

- A. Review requirements for sequencing of installation of weather barrier assembly with installation of windows, doors, louvers and flashings to provide a weather-tight barrier assembly.

1.07 SUBMITTALS

- A. Submit manufacturer's installation instructions under provisions of Section 01 33 00.

1.08 DELIVERY, STORAGE AND HANDLING

- A. Deliver, store, protect and handle products to site under provisions of Section 01 60 00.
- B. Deliver weather barrier materials and components in manufacturer's original, unopened, undamaged containers with identification labels intact.
- C. Store weather barrier materials as recommended by system manufacturer.

PART 2 - PRODUCTS

2.01 MANUFACTURERS

- A. Basis of design:
 - 1. DuPont : Tyvek Commercial Wrap
- B. Substitutions: Under provisions of Section 01 60 00.

2.02 MATERIAL PROPERTIES

- A. Air infiltration barrier material shall meet or exceed the following performance characteristics:
 - 1. Air Permeance, product: Not more than 0.001 cfm/ft² at 1.57 lbf/sq. ft., when tested in accordance with ASTM E2178. Type I per ASTM E1677.
 - 2. Water Penetration Resistance, Product: Hydrostatic head resistance greater than 7.7 feet (280 cm) in accordance with AATTC 127.
 - 3. Water-Vapor Permeance: Not less than 23 perms per ASTM E 96/E 96M, Desiccant Method (Procedure A) or not less than 28 perms per ASTM E 96/E 96M, Water Method (Procedure B).
 - 4. Surface Burning Characteristics: Class A, when tested in accordance with ASTM E84. Flame Spread: 15, Smoke Developed: 15
 - 5. Basis Weight: 2.7 oz/yd², when tested in accordance with TAPPI Test Method T-410.
 - 6. Tensile (Breaking) Strength: 38/35 lbs/in., when tested in accordance with ASTM D882.
 - 7. Tear Resistance: 12/10 lbs, when tested in accordance with ASTM D1117.

2.03 ACCESSORIES

- A. Seam Tape: 2 inch wide, DuPont™ Tyvek® Tape as distributed by DuPont Building Innovations.
- B. Fasteners:
 - 1. DuPont™ Tyvek® Wrap Cap Screws (or equal): 1-5/8 inch rust resistant screw with 2-inch diameter plastic cap or manufacturer approved 1-1/4" or 2" metal gasketed washer.
- C. Sealants
 - 1. Provide sealants that comply with ASTM C 920, elastomeric polymer sealant to maintain watertight conditions. Sealants recommended by the weather barrier manufacturer.

- D. Adhesive:
 - 1. Provide adhesive recommended by weather barrier manufacturer.
 - 2. Products:
 - a. Liquid Nails® LN-109
 - b. Denso Butyl Liquid
 - c. 3M High Strength 90
 - d. SIA 655

- E. Primer:
 - 1. Provide flashing manufacturer recommended primer to assist in adhesion between substrate and flashing.
 - 2. Products:
 - a. 3M High Strength 90
 - b. Denso Butyl Spray
 - c. SIA 655
 - d. Permagrip 105
 - e. ITW TACC Sta' Put SPH

- F. Window and Door Flashing
 - 1. DuPont™ FlexWrap NF, as distributed by DuPont: flexible membrane flashing materials for window openings and penetrations.
 - 2. DuPont™ StraightFlash™, as distributed by DuPont: straight flashing membrane materials for flashing windows and doors and sealing penetrations, masonry ties, etc.

PART 3 - EXECUTION

3.01 PREPARATION

- A. Verify substrate and adjacent materials are dry and ready to receive air infiltration barrier.

3.02 INSTALLATION

- A. Install weather barrier over exterior face of exterior wall substrate in accordance with manufacturer recommendations.
- B. Start weather barrier installation at a building corner, leaving 6-12 inches of weather barrier extended beyond corner to overlap.
- C. Install weather barrier in a horizontal manner starting at the lower portion of the wall surface. Maintain weather barrier plumb and level.
- D. Extend bottom roll edge over sill plate interface 2" to 3" minimum. Seal weather barrier with sealant or tape. Shingle weather barrier over back edge of thru-wall flashings and seal weather barrier with sealant or tape. Ensure weeps are not blocked.

- E. Subsequent layers shall overlap lower layers a minimum of 6 inches horizontally in a shingling manner.
- F. Window and Door Openings: Extend weather barrier completely over openings.
- G. Weather Barrier Attachment:
 - 1. Attach weather barrier to studs through exterior sheathing. Secure using weather barrier manufacturer recommended fasteners, spaced 12 -18 inches vertically on center along stud line, and 24 inch on center, maximum horizontally.
- H. Apply 4 inch by 7 inch piece of DuPont™ StraightFlash™ or weather barrier manufacturer approved alternate to weather barrier membrane prior to the installation cladding anchors.

3.03 SEAMING

- A. Seal seams of weather barrier with seam tape at all vertical and horizontal overlapping seams.
- B. Seal any tears or cuts as recommended by weather barrier manufacturer.

3.04 OPENING PREPARATION

- A. Completely cover openings with weather barrier, then cut weather barrier membrane to openings according to weather barrier manufacturer's installation guidelines.
- B. Cut weather barrier in an “I-cut” pattern. A modified I-cut is also acceptable.
 - 1. Cut weather barrier horizontally along the bottom and top of the window opening.
 - 2. From the top center of the window opening, cut weather barrier vertically down to the sill
 - 3. Fold side and bottom weather barrier flaps into window opening and fasten.
- B. Cut a head flap at 45-degree angle in the weather barrier membrane at window head to expose 8 inches of sheathing. Temporarily secure weather barrier membrane flap away from sheathing with tape.

3.05 FLASHING

- A. Cut 9-inch wide DuPont™ FlexWrap NF a minimum of 12 inches longer than width of sill rough opening. Apply primer as recommended by the manufacturer.
- B. Cover horizontal sill by aligning DuPont™ FlexWrap NF edge with inside edge of sill. Adhere to rough opening across sill and up jambs a minimum of 6 inches. Secure flashing tightly into corners by working in along the sill before adhering up the jambs.
- C. Fan DuPont™ FlexWrap NF at bottom corners onto face of wall. Firmly press in place. Mechanically fasten fanned edges.
- D. On exterior, apply continuous bead of sealant to wall or backside of window mounting flange across jambs and head. Do not apply sealant across sill.

- E. Install window according to manufacturer's instructions.
- F. Apply 4-inch wide strips of DuPont™ StraightFlash™ at jambs overlapping entire mounting flange. Extend jamb flashing 1-inch above top of rough opening and below bottom edge of sill flashing.
- G. Apply 4-inch wide strip of DuPont™ StraightFlash™ as head flashing overlapping the mounting flange. Head flashing should extend beyond outside edges of both jamb flashings.
- H. Position weather barrier head flap across head flashing. Adhere using 4-inch wide DuPont™ StraightFlash™ over the 45-degree seams.
- I. Tape head flap in accordance with manufacturer recommendations.
- J. On interior, install backer rod in joint between frame of window and flashed rough framing. Apply sealant around entire window to create air seal. Apply sealant in accordance with sealant manufacturer's instructions and ASTM C1193.

3.06 CLEANING

- A. Clean work under provisions of Section 01 70 00.

END OF SECTION

THIS PAGE INTENTIONALLY LEFT BLANK

SECTION 07 31 13

ARCHITECTURAL ROOF SHINGLES

PART 1 - GENERAL

1.01 SECTION INCLUDES

- A. Granular surfaced shingle roofing.
- B. Moisture shedding underlayment, eave, valley and ridge.
- C. Associated metal flashings.

1.02 REFERENCES

- A. ANSI/ASTM B209 - Aluminum Alloy Sheet and Plate.
- B. ANSI/ASTM D226 - Roofing and waterproofing
- C. ANSI/ASTM E108 - Standard Test Method for Fire Resistance.
- D. ANSI/ASTM D1922 - Propagation tear resistance of plastic film and thin sheeting by pendulum method.
- E. ANSI/ASTM D3018 - Standard Specification for class A Asphalt Shingles.
- F. ANSI/ASTM D3161 - Standard Test Method for Wind Resistance of Asphalt Shingles (Organic or Fiberglass)
- G. ANSI/ASTM D3462 - Standard Specification for Asphalt Shingles. (Fiberglass)
- H. ANSI/ASTM D2822 - Asphalt Roof Cement.
- I. SMACNA MANUAL - Architectural Sheet Metal Manual.

1.04 SUBMITTALS

- A. Submit under provisions of Section 01 33 00.
- B. Shop Drawings: Indicate metal flashings, jointing methods and locations, fastening methods and locations, and installation details.
- C. Product Data: Provide data indicating material characteristics, performance criteria and limitations.
- D. Manufacturer's Certificate: Certify that roof shingles meet or exceed:
 - 1. ASTM E108 Class A Fire Resistance
 - 2. ASTM D3161 Wind Resistance
 - 3. ASTM D1922 Tear Strength

- 4. ASTM D3018 Type 1
- 5. ASTM D3462 Standard for Asphalt Shingles. (Must have Independent certification)

E. Manufacturer's Installation Instructions

F. Samples: Submit samples indicating the full color range from the manufacturer's standard colors.

1.05 QUALITY ASSURANCE

A. Perform this work in accordance with the Asphalt Roofing Manufacturers Association Residential Asphalt Roofing Manual. Copies may be obtained at the:
Asphalt Roofing Manufacturers Assoc.

B. Maintain one copy on site at all times.

C. Manufacturer: Company specializing in manufacturing the products specified in this section with a minimum of five years of documented experience.

D. Installer: Company specializing in performing the work of this section with a minimum of five years of verifiable documented experience. Contractor must be a credentialed "Certainteed ShingleMaster Applicator."

E. Use only trained workmen skilled in the installation of this type of work. The foreman shall have a minimum of five years of verifiable documented experience.

F. Upon request furnish the name, location and contact person of previous roofing installations to the owner and the Architect.

1.06 REGULATORY REQUIREMENTS

A. Conform to Code for ASTM D3018 Class A, UL 790 Fire resistance and UL 58 Wind Uplift for shingle types specified.

B. Conform to Code for ASTM D3462 Tear resistance.

C. Conform to insurance requirements identified by owner or its representative.

D. Provide certificate of compliance from ASTM and UL indicating approval of specified products.

E. Submit evidence of applicable insurance requirements.

F. Conform to all applicable Federal, State and local codes and laws.

1.07 DELIVERY, STORAGE, AND HANDLING

A. Deliver, store, protect, and handle products under the manufacturer's recommendation and under provisions of Section 01 60 00.

B. Deliver materials in their original, unopened containers, dry, undamaged, sealed and labels intact.

- C. Stand roll materials on end.
- D. Store other materials flat, elevated from ground or roof deck, protected with waterproof covers as necessary to keep the materials dry.
- E. Protect materials from damage. Do not use materials damaged in handling or storage. Replace damaged materials at no additional cost to the Owner.
- F. When storing materials on the roof, and during application, the roofing contractor shall ensure that overloading of the deck and structure does not occur.

1.08 ENVIRONMENTAL REQUIREMENTS

- A. Do not install roofing materials during inclement weather.
- B. Do not install ice and water protection and shingles when ambient temperature is below 50 degrees Fahrenheit.
- C. Do not install roofing materials to damp or frozen deck.
- D. Do not expose materials vulnerable to water or sun damage in quantities greater than can be weatherproofed during the same day.
- E. Any damaged or deteriorated deck or flashing substrate which is discovered shall be promptly reported to the owner or his designated representative.

1.09 WARRANTY

- A. Upon completion of the roof system and after passing a final inspection performed by the roofing manufacturer and the owners representative. The manufacturer's Warranty will be furnished for the work of this section as follows:
 - 1. ROOF SHINGLE: 50 Year warranty
- B. Warranty Extension: Manufacturer of shingle will provide a Surestart-Plus warranty with 5-Star Protection to cover labor, materials, tear-off, disposal and workmanship in the event of a materials defect during the first thirty (30) years after completion of application of shingles.
- C. Provide fifteen (15) year, 110 mph wind-resistance warranty
- D. Provide 15-year StreakFighter™ warranty.
- E. Provide 15 year Algae Resistant warranty.

1.10 EXTRA MATERIALS

- A. Furnish under provisions of Section 01 78 00.
- B. Provide two bundles of shingles packaged as required for long term storage.

PART 2 - PRODUCTS

2.01 MANUFACTURERS

- A. Basis of Design: Shingles
CertainTeed Corporation
Style: Landmark Pro AR
Color: As selected by Architect from manufacturer's standard colors.
- B. Basis of Design: Ridge Vent
CertainTeed Corporation
Style: CertainTeed Ridge Vent, 9" Filtered Class A Fire-rated
- C. Basis of Design: Soffit, vented drip edge and flashing vent.
Air Vent Inc
- D. Substitutions: Under provisions of Section 01 60 00.

2.02 MATERIALS

- A. ROOF SHINGLES
 - 1. Roof shingle shall conform to ASTM D 3018 Type I – Self-Sealing; UL Certification of ASTM D 3462, ASTM D 3161/UL997 80 mph Wind Resistance and UL Class A Fire Resistance; glass fiber mat base; ceramically coated, colored algae resistant granules across entire face of the shingle; two-piece laminated shingle.
Minimum weight of 250 lb. per square.
Provide associated Starter Shingles.
 - 2. Color selected by Architect from manufacturer's standard colors.
- B. DRIP EDGE:
 - 1. Aluminum, ASTM B209, pre-formed, 1/2 inch extension for drip break back for 1 inch vertical fascia, minimum 3 inch railing on roof surface.
 - 2. Color selected by Architect from manufacturer's standard colors.
- C. GABLE EDGE:
 - 1. Aluminum, ASTM B209, pre-formed, 1 inch vertical fascia, minimum 3 inch railing on roof surface.
 - 2. Color selected by Architect from manufacturer's standard colors.
- D. SHEET MATERIALS
 - 1. Underlayment: DiamondDeck by CertainTeed, or equal, is a synthetic polymer-based scrim-reinforced underlayment. Low-slope application minimum 2" per foot. Between slopes of 2" per foot up to 4" per foot apply two layers of DiamondDeck in "shingle-fashion" as described in the installation instructions.
 - 2. Eave and valley protection (Ice and Water Shield): WinterGuard by CertainTeed or equal: A sheet barrier of self adhering, rubberized asphalt membrane shingle underlayment having a high traction surface and internal reinforcement. The material must have a warranty equal or greater in duration to that of the shingles being applied.

- E. GUTTERS AND DOWNSPOUTS: See specification section 07 71 23.

2.03 ACCESSORIES

- A. Nails: Standard round wire type, (hot dipped zinc coated steel) with a minimum 7/16 head diameter and 0.104 inch shank diameter, (minimum 7/8 inch long) or of sufficient length to penetrate through roof sheathing and into the substrate. (a minimum of 1/2 inch).
- B. Plastic Cement: ASTM D2822 asphalt type with mineral fiber components, free of toxic solvents and asbestos, capable of setting within 24 hours at temperature of 75 degrees F and 50% RH. #19 cold cement manufactured by Karnak.
- C. Lap Cement: Fiberated cutback asphalt type, recommended for use in application underlayment, free of toxic solvents and asbestos: #16 double coverage cement manufactured by Karnak.

2.04 FLASHING MATERIALS

- A. Sheet flashings: Lead coated copper
- B. Bituminous Paint: Acid and alkali resistant type (color black).
- C. Nails: Standard round wire type, (hot dipped zinc coated steel) with a minimum 7/16 head diameter and 0.104 inch shank diameter, (minimum 7/8 inch long) or of sufficient length to penetrate through roof sheathing and into the substrate. (a minimum of 1/2 inch).

2.05 FLASHING FABRICATION

- A. Form flashings to protect roofing materials from physical damage and to shed water
- B. Form sections square and accurate to profile, in maximum possible lengths, free from distortion or defects detrimental to appearance or performance.
- C. Hem exposed edges of flashings minimum 1/4 inch on underside.
- D. Apply bituminous paint on concealed surfaces of flashings.

PART 3 - EXECUTION

3.01 EXAMINATION

- A. Any damages caused by the contractor's operations shall be repaired to the satisfaction of the owner at the contractor's expense.
- B. The roofing contractor shall carefully examine the roof area in regards to dimensions, and type of substrate and conditions that may affect proper execution of the work. Any variations shall be reported to the owner's representative and the Architect prior to the bid. "No claims for extra costs shall be allowed because of lack of full knowledge of existing conditions".
- C. Verify existing site conditions.

- D. Verify that roof openings, curbs, pipes, sleeves, ducts and vents through roof are solidly set, and wood, cant strips, wood nailing strips, and reglets are properly set and in place.
- E. Beginning of roof project means installer accepts existing conditions.

3.02 PROTECTION

- A. Schedule and execute all work without exposing the building interior to the effects of inclement weather. Protect the building, contents, and its inhabitants against all risks associated with this work.
- B. Provide suitable barricades to protect the general public.

3.03 PREPARATION

- A. Verify deck is clean and smooth, free of depressions, waves, or projections.
- B. Fill Knot holes and surface cracks with a latex filler at areas of bonded eave protection.
- C. Broom clean deck surfaces under eave protection and underlayment.

3.04 INSTALLATION - PROTECTIVE UNDERLAYMENT

- A. Place underlayment over entire roof surface and install in accordance with manufacturer's instructions. Nail in place. No staples allowed. See drawings for various roof slopes.
- B. Install protective underlayment perpendicular to slope of roof.
- C. Weather lap and seal watertight with plastic cement, items projecting through mounted on roof.

3.05 INSTALLATION - EAVE ICE DAM PROTECTION

- A. Place eave edge and gable edge metal flashings tight with fascia boards. Weather lap joints 2 inches and seal with plastic cement. Secure flange with nails spaced 2 on center.
- B. Apply the self adhering, rubberized asphalt membrane eave ice dam protection under No.15 roofing felt at all eaves in accordance with manufacturer's instructions.
- C. Extend eave ice dam protection membrane from the eave's edge up the slope a minimum of 3 feet inside the exterior wall line of the building unless noted otherwise as a greater dimension on the drawings.

3.06 INSTALLATION - VALLEY PROTECTION

- A. Place one layer of self adhering, rubberized asphalt membrane, centered over valleys extending 18 inches both sides of valley. Lap joints minimum of 6 inches. Valley protection shall be applied in accordance with manufacturer's instructions.

- B. Valley liner shall be 24 oz. zinc-coated copper, 24 inches wide, installed over the layer of rubberized asphalt membrane. Copper valley liner shall have a 1 inch V crimp in the center. The edges of the valley metal shall be formed with a hooked edge and metal cleats shall be installed 2 foot on center. Shingles shall lap the flashing metal a minimum of 6 inches. All valley metal shall be installed in 8 foot sections. Sections shall be securely nailed at the top of each section with nails compatible with the flashing material. All sections shall be lapped a minimum of 8 inches in the direction of the water flow. (Reference SMACNA manual plate #61.)

3.07 INSTALLATION - METAL FLASHINGS

- A. Weather lap joints a minimum of 2 inches and seal weather tight with plastic cement.
- B. Secure in place with nails at 2 inches on center. Conceal fastenings.
- C. Flash and seal work projecting through or mounted on roofing with plastic cement to make weather tight.
- D. Flashing metal shall be corrosion resistant.

3.08 INSTALLATION - ROOF SHINGLES

- A. Install shingles in accordance with manufacturer's instructions.
- B. Place shingles in straight coursing pattern with weather exposure as recommended by the manufacturer to produce double thickness over entire roof area and as required to meet the warranty. Provide double course of shingles at eaves and gables.
- C. Project first course of shingles 3/4 inch beyond fascia boards.
- D. Extend shingles 1/2 inch beyond face of gable edge fascia boards.
- E. Cap Hips and ridges with individual shingles, maintaining 5 inch weather exposure. Place to avoid exposed nails.
- F. Install shingles using "Hurricane Nailing" of six nails per shingle.

3.09 FIELD QUALITY CONTROL

- A. Field inspection by manufacturer's representative will be performed under provisions of Section 01 43 00.
- B. Field inspections of the work will also be performed by the Owners designated representative and or the Architect.
- C. Repair or replace defaced or disfigured finishes caused by work of this section.

3.10 PROTECTION OF FINISHED WORK

- A. Protect finished work under provisions of Section 01 70 00.

- B. Do not permit traffic over finished roof surface.

END OF SECTION

SECTION 07 46 24

CEDAR SHINGLE SIDING

PART 1 - GENERAL

1.01 SUMMARY

- A. Section Includes: Red Cedar Natural Shingles.
- B. Related Sections:
 - 1. Division 6 Section: Finish Carpentry for sheathing.
 - 2. Division 7 Section: Sheet Metal Flashing and Trim for flashing, gutters, and other sheet metal work.
 - 3. Division 7 Section: Joint Sealants for field-applied sealants.

1.02 REFERENCES

- A. American Society for Testing and Materials (ASTM):
 - 1. ASTM E84 Standard Test Method for Surface Burning Characteristics of Building Materials.
- B. Underwriters Laboratories

1.03 SUBMITTALS

- A. General: Submit listed submittals in accordance with Section 01330.
- B. Product Data: Submit manufacturer's product data and installation instructions.
- C. Samples: Submit shingles for each color, texture and pattern specified.

1.04 QUALITY ASSURANCE

- A. Qualifications: Engage an experienced installer who has completed siding installations similar in material, design and extent to that indicated.
- B. Regulatory Requirements and Approvals: Meet all federal, state and local codes and laws.
- C. Mock-Ups: Construct sample wall panels to verify selections made under sample submittals and to demonstrate aesthetic effects and qualities of materials and execution.

1.05 DELIVERY, STORAGE & HANDLING

- A. Deliver, store and handle products under provisions of Section 01600.
- B. Delivery: Deliver materials in manufacturer's original, unopened, undamaged containers with identification labels intact.
- C. Storage and Protection: Store materials protected from exposure to harmful environmental conditions and at temperature and humidity conditions recommended by the manufacturer.

PART 2 - PRODUCTS

2.01 RED CEDAR SHINGLES

- A. Material: Western Red Cedar Natural Shingles, Grade A, Number 1 grade, Blue Label Certigrade, Rebutted and rejointed.
- B. Configuration: Even, level butt line.
- C. Surface texture to be smooth-sawn.
- D. Size: 16 inches long; 0.40 inch thick at butt.

- E. Finish: Two coats of C2 Guard Fusion clear waterproofer manufactured by C2 Paint
OR
1 coat of oil based cedar tone, transparent finish applied & baked-on at manufacturing plant / cedar mill.

2.02 ACCESSORIES

- A. Nails:
 - 1. Material: Stainless steel No. 316
 - 2. Size: Fasteners should be of sufficient length to penetrate sheathing.
- B. Air infiltration barrier as specified.
- C. Drainage Mat: Tyvek DrainWrap or equal.
Install in accordance with manufacturer's instructions.

PART 3 - EXECUTION

3.01 MANUFACTURER'S INSTRUCTIONS

- A. Comply with the instructions and recommendations of the Cedar Shingle manufacturer.

3.02 PREPARATION

- A. Determine prior to framing layout which corner treatment is to be utilized.
- B. After framing is completed, install air infiltration barrier horizontally, shingle style, beginning at bottom of wall with 3" overlaps.
- C. Install Drainage Mat per manufacturer's instructions.

3.03 INSTALLATION

- A. Install shingles by attaching to solid nailable sheathing.
- B. Install working from the lowest level up to the top of the wall area.
- C. Fur-out the bottom course of siding with wood strips. Allow for canting of the first course of shingles and determining level line.
- D. Offset joints between shingles in succeeding courses a minimum of 1-1/2 inches
- E. Drive nails flush with shingle surface, penetrating sheathing at least 1/2 inch.
- F. Maintain spacing between shingles and trim to allow for natural expansion.
- G. Maintain weather exposure of 6 inches.
- H. Caulk joints as required.
- I. Interior corner treatment: Laced with flashing behind.
- J. Exterior corner treatment: Laced.

3.04 PROTECTION

- A. Protect Cedar Shingles from damage during construction.

END OF SECTION

SECTION 07 46 46

FIBER CEMENT SOFFIT AND TRIM

PART 1 GENERAL

1.1 SECTION INCLUDES

- A. Fiber cement trim, soffit, and accessories.

1.2 RELATED SECTIONS

- A. Section 06 20 10 - Carpentry: Wood framing and bracing.

1.3 REFERENCES

- A. ASTM C1186 - Standard Specification for Flat Non-Asbestos Fiber-Cement Sheets.
- B. ASTM E 84 - Standard Test Method for Surface Burning Characteristics of Building Materials.
- C. ASTM E119 - Standard Test Methods for Fire Tests of Building Construction and Materials.
- D. ASTM E136 - Standard Test Method for Behavior of Materials in a Vertical Tube Furnace at 750 degrees C.

1.4 SUBMITTALS

- A. Submit under provisions of Section 01 33 00.
- B. Product Data: Manufacturer's data sheets on each product to be used, including:
 - 1. Preparation instructions and recommendations.
 - 2. Storage and handling requirements and recommendations.
 - 3. Installation methods.
- C. Shop Drawings: Provide detailed drawings of a typical non-standard applications of cementitious siding materials which are outside the scope of the standard details and specifications provided by the manufacturer.
- D. Selection Samples: For each finish product specified, two complete sets of color chips representing manufacturer's full range of available colors and patterns.
- E. Verification Samples: For each finish product specified, two samples, minimum size 4 by 6 inches, representing actual product, color, and patterns.

1.5 QUALITY ASSURANCE

- A. Installer Qualifications: Minimum of 2 years experience with installation of similar products.

1.6 DELIVERY, STORAGE, AND HANDLING

- A. Deliver, store and handle products under provisions of Section 01 60 00.
- B. Store products in manufacturer's unopened packaging until ready for installation.
- C. Store siding on edge or lay flat on a smooth level surface. Protect edges and corners from chipping. Store sheets under cover and keep dry prior to installing.

- D. Store and dispose of solvent-based materials, and materials used with solvent-based materials, in accordance with requirements of local authorities having jurisdiction.

1.7 PROJECT CONDITIONS

- A. Maintain environmental conditions (temperature, humidity, and ventilation) within limits recommended by manufacturer for optimum results. Do not install products under environmental conditions outside manufacturer's absolute limits.

1.8 WARRANTY

- A. Product Warranty: Limited product warranty against manufacturing defects.
 - 1. HardieTrim boards for 10 years.
 - 2. HardieSoffit panels for 25 years
- B. Workmanship Warranty: Application limited warranty for 2 years.
- C. Provide warranties under provisions of Section 01 78 00.

PART 2 PRODUCTS

2.1 MANUFACTURERS

- A. James Hardie Building Products, Inc., 26300 La Alameda Suite 250 ; Mission Viejo, CA 92691.
- B. Substitutions under provisions of Section 01 60 00.

2.2 MATERIALS

- A. Code Compliance Requirement for Materials:
 - 1. National Evaluation Report No. NER 405 (BOCA, ICBO, SBCCI, IBC, IRC).
 - 2. Non-asbestos fiber-cement siding where required to be non-combustible shall be tested in accordance with ASTM E136.
 - 3. Fiber-cement material - complies with ASTM E 84 Flame Spread Index = 0, Smoke Developed Index = 5.
 - 4. Fiber-cement material - complies with ASTM C 1186 Type A Grade II.
- B. Trim:
 - 1. HardieTrim boards with smooth finish.
- C. See drawings for locations.

2.3 FASTENERS

- A. Sheet, board and trim fasteners: Stainless steel fastener as recommended by manufacturer and as required by building code.
- B. Wood Framing Fasteners: as recommended by manufacturer and as required by building code.

2.4 SEALANT

- A. Provide sealant that matches the color of the adjacent materials.

2.5 FINISHES

- A. Provide factory-applied finishes to all fiber cement products as follows:
 - 1. Primer: PrimePlus by James Hardie or equal.
 - 2. Surface paint is to be field applied.

PART 3 EXECUTION

3.1 EXAMINATION

- A. Do not begin installation until substrates have been properly prepared.
- B. Framing complying with local building codes, including the use of air infiltration barrier where required or specified.
Minimum 1-1/2 inches face and straight, true, of uniform dimensions and properly aligned.
 - 1. Install air infiltration barrier and claddings to dry surfaces.
 - 2. Repair any punctures or tears in the air infiltration barrier prior to the installation of the siding.

3.2 PREPARATION

- A. Clean surfaces thoroughly prior to installation.
- B. Prepare surfaces using the methods recommended by the manufacturer for achieving the best result for the substrate under the project conditions.

3.3 INSTALLATION - TRIM BOARDS

- A. Install materials in strict accordance with manufacturer's installation instructions. Install flashing around all wall openings.
- B. Fasten through trim into structural framing or code complying sheathing. Fasteners must penetrate minimum 3/4 inch or full thickness of sheathing. Additional fasteners may be required to ensure adequate security.
- C. Place fasteners no closer than 3/4 inch and no further than 2 inches from side edge of trim board and no closer than 1 inch from end. Fasten maximum 16 inches on center.
- D. Maintain clearance between trim and adjacent finished grade.
- E. Trim inside corner with single board.
- F. Allow 1/8 inch gap between trim and siding.
- G. Seal gap with high quality, paintable caulk.

3.4 PROTECTION

- A. Protect installed products until completion of project.
- B. Touch-up, repair or replace damaged products before Substantial Completion.

3.5 CLEANING

- A. Clean under provisions of Section 01 70 00.
- B. Dispose of excess materials and debris from jobsite.

END OF SECTION

SECTION 07 54 23

SELF-ADHERED THERMOPLASTIC POLYOLEFIN ROOFING SYSTEM

PART 1 - GENERAL

1.01 DESCRIPTION

- A. The project consists roofing using TPO (Thermoplastic Polyolefin)

1.02 EXTENT OF WORK

- A. Provide all labor, material, tools, equipment, and supervision necessary to complete the installation of the .060" thick white reinforced TPO (Thermoplastic Polyolefin) reinforced membrane Adhered Roofing System including flashings and recover board as specified herein and as indicated on the drawings in accordance with the manufacturer's most current specifications and details.
- B. The roofing contractor shall confirm all given information and advise the Architect, prior to bid, of any conflicts that will affect their cost proposal.
- C. The roofing contractor shall be fully knowledgeable of all requirements of the contract documents and shall make themselves aware of all job site conditions that will affect their work.

1.03 SUBMITTALS

- A. Submit under provisions of Section 01 33 00
- B. Prior to starting work, the roofing contractor must submit the following:
1. Shop drawings showing layout, details of construction and identification of materials.
 2. A sample of the manufacturer's Membrane System Warranty.
 3. Submit a letter of certification from the manufacturer which certifies the roofing contractor is authorized to install the manufacturer's roofing system and lists foremen who have received training from the manufacturer along with the dates training was received.
 4. Certification from the membrane manufacturer indicating the membrane thickness over the reinforcing scrim (top ply membrane thickness) is nominal .015" (15 mil) or thicker
 5. Certification of the manufacturer's warranty reserve.
 7. Verify ASCE-7 wind uplift requirements and associated fastening patterns.
 8. Submit a composition letter on the manufacturer's letterhead listing all required components and fastening of the roof system necessary to meet the manufacturer's warranty requirements.
- C. Upon completion of the installed work, submit copies of the manufacturer's final inspection to the specifier prior to the issuance of the manufacturer's warranty.

1.04 PRODUCT DELIVERY, STORAGE AND HANDLING

- A. Deliver, store, protect and handle products to site under provisions of Section 01 60 00
- B. Deliver materials to the job site in the manufacturer's original, unopened containers or wrappings with the manufacturer's name, brand name and installation instructions intact and legible. Deliver in sufficient quantity to permit work to continue without interruption.
- C. Comply with the manufacturer's written instructions for proper material storage.
 - 1. Store membrane in the original undisturbed plastic wrap in a cool, shaded area. Membrane that has been exposed to the elements for approximately 7 days must be prepared with Carlisle Weathered Membrane Cleaner prior to hot air welding.
 - 2. Store curable materials (adhesives and sealants) between 60°F and 80°F in dry areas protected from water and direct sunlight. If exposed to lower temperature, restore to 60°F minimum temperature before using.
 - 3. Store materials containing solvents in dry, well ventilated spaces with proper fire and safety precautions. Keep lids on tight. Use before expiration of their shelf life.
- D. Insulation and recover boards must be on pallets, off the ground and tightly covered with waterproof materials.
- E. Any materials which are found to be damaged shall be removed and replaced at the Contractor's expense.

1.05 WORK SEQUENCE

- A. Schedule and execute work to prevent leaks and excessive traffic on completed roof sections. Care should be exercised to provide protection for the interior of the building and to ensure water does not flow beneath any completed sections of the membrane system.
- B. Do not disrupt activities in occupied spaces.

1.06 PRE-INSTALLATION CONFERENCE

- A. The primary Contractor, Subcontractors, the Owner or the Owner's representative and the Architect shall conduct a pre-roofing conference a minimum of one week before any work begins so all parties involved in the installation of the roofing system construction, or who may work on or through the roofing system, understand their obligations with respect to the roofing project and materials.
- B. Review installation procedures and coordination required with Owner for related work.

1.07 REGULATORY REQUIREMENTS

- A. Conform to all applicable Federal, State, and Local Codes.

- B. The applicator shall submit evidence that the proposed roof system meets the requirements of the state building code and has been tested and approved or listed by the following test organizations. These requirements are minimum standards and no roofing work shall commence without written documentation of the system's compliance.
 - 1. American Society of Civil Engineers (ASCE)
 - a. Comply with wind loads as stated in ASCE 7.
 - 2. Underwriters Laboratories, Inc. - Northbrook, IL
 - a. Class A assembly

1.08 QUALIFICATIONS

- A. Manufacturer and installer must have specialized in performing the work of this section with a minimum of five (5) years documented experience. Installer must be approved by the manufacturer.

1.09 SAFETY

- A. The roofing contractor shall be responsible for all means and methods as they relate to safety and shall comply with all applicable local, state and federal requirements that are safety related. Safety shall be the responsibility of the roofing contractor. All related personnel shall be instructed daily to be mindful of the full time requirement to maintain a safe environment for the facility's occupants including staff, visitors, customers and the occurrence of the general public on or near the site.

1.10 QUALITY ASSURANCE

- A. The membrane roofing system must achieve a UL Class A rating (for high wind exposure at 72 MPH).
- B. Enclosed building height is approximately 15 feet above finish grade for the upper roof.
- C. The roofing system must meet the state requirements for the basic 138 mph wind speed zone.
- D. Unless otherwise noted in this specification, the roofing contractor must strictly comply with the manufacturer's current specifications and details.
- E. The roofing system must be installed by an applicator authorized and trained by the manufacturer in compliance with shop drawings as approved by the manufacturer.
- F. Provide adequate number of experienced workmen regularly engaged in this type of work who are skilled in the application techniques of the materials specified including operation of hot air welding equipment and power supply. Provide at least one thoroughly trained and experienced superintendent on the job at all times roofing work is in progress.
- G. There shall be no deviations made from this specification or the approved shop drawings without the prior written approval of the specifier. Any deviation from the manufacturer's installation procedures must be supported by a written certification on the manufacturer's letterhead and presented for the specifier's consideration.
- H. Upon completion of the installation, the applicator shall arrange for an inspection to be made by a

non-sales technical representative of the membrane manufacturer in order to determine whether or not corrective work will be required before the warranty will be issued. Notify the building owner seventy-two (72) hours prior to the manufacturer's final inspection.

1.11 JOB CONDITIONS, CAUTIONS AND WARNINGS

- A. Material Safety Data Sheets (MSDS) must be on location at all times during the transportation, storage and application of materials.
- B. When positioning membrane sheets, exercise care to locate all field splices away from low spots and out of drain sumps. All field splices should be shingled to prevent bucking of water.
- C. When loading materials onto the roof, the Contractor must be careful to prevent overloading and possible disturbance to the building structure.
- D. Proceed with roofing work only when weather conditions are in compliance with the manufacturer's recommended limitations, and when conditions will permit the work to proceed in accordance with the manufacturer's requirements and recommendations.
- E. Proceed with work so new roofing materials are not subject to construction traffic. When necessary, new roof sections shall be protected and inspected upon completion for possible damage.
- F. Provide protection, such as 3/4 inch thick plywood, for all roof areas exposed to traffic during construction. Plywood must be smooth and free of fasteners and splinters.
- G. The surface on which the recover board and roofing membrane is to be applied shall be clean, smooth, dry, and free of projections or contaminants that would prevent proper application of or be incompatible with the new installation, such as fins, sharp edges, foreign materials, oil and grease.
- H. New roofing shall be complete and weather tight at the end of each work day.
- I. Contaminants such as grease, fats and oils shall not be allowed to come in direct contact with the roofing membrane.
- J. Before beginning work, the roofing contractor must secure approval from the building owner's representative for the following:
 - 1. Areas permitted for personnel parking.
 - 2. Access to the site.
 - 3. Areas permitted for storage of materials and debris.
 - 4. Areas permitted for the location of cranes, hoists and chutes for loading and unloading materials to and from the roof.
- K. Interior stairs or elevators may not be used for removing debris or delivering materials, except as authorized by the building Owner.
- L. Protect building to be reroofed, adjacent buildings, walkways, site improvements, exterior plantings, and landscaping from damage or soiling from reroofing operations.

1.12 WARRANTY

- A. Provide manufacturer's 20 year Total System Warranty covering both labor and material with no dollar limitation. The maximum wind speed coverage shall be peak gusts of 90 MPH measured at 10 meters above ground level. Certification is required with bid submittal indicating the manufacturer has reviewed and agreed to such wind coverage.
- B. Pro-rated System Warranties shall not be accepted.
- C. Evidence of the manufacturer's warranty reserve shall be included as part of the project submittals for the specifier's approval.
- D. Applicator/Roofing Contractor Warranty
The Applicator shall supply the Owner with a separate two (2) year workmanship warranty. In the event any work related to roofing, flashing, or metal is found to be within the Applicator warranty term, defective or otherwise not in accordance with the Contract Documents, the Applicator shall repair that defect at no cost to the Owner. The Applicator's warranty obligation shall run directly to the Owner.
- E. Thermal Performance Warranty: Warrants the thermal insulation "R" value of the system shall not diminish to less than 80% of the published "R" value the time of purchase for a period of ten (10) years.
- F. The warranty for the Kynar 500 finish on the metal edging is for thirty (30) years against chalk, fade and film integrity.

PART 2 - PRODUCTS

2.01 MANUFACTURER

- A. Carlisle SynTec Incorporated: Sure-Weld SAT 60-mil reinforced TPO
- B. Other acceptable manufacturers offering equivalent products.
 - GAF: Everguard Freedom TPO HW self-adhering
 - Firestone: Ultraply TPO Flex SA
- C. Substitutions under provisions of Section 01 60 00.
- D. All products (including insulation, fasteners, fastening plates, prefabricated accessories and edgings) must be manufactured and/or supplied by the roofing system manufacturer and covered by the warranty.

2.02 MEMBRANE

- A. Provide Sure-Weld SAT (SelfAdhering Technology) 60-mil thick Reinforced Thermoplastic Polyolefin (TPO) membrane (white color). Membrane thickness over the reinforcing scrim (top-ply thickness) shall be nominal .015" thick (15 mil) or greater. Minimum size of membrane sheets is to be 10' wide by 50' or 100' long. Perimeter membrane sheets are available in widths of 6' by 100' long.

Cool Roof Rating Council (CRRC) Product ID# 0628-0002
Solar Reflectance: 0.79
Thermal Emittance: 0.90
Solar Roof Index (SRI): 99

- B. Contractor's Option: Provide Carlisle APEEL (or equal) protective film on the surface of the TPO roofing membrane. Remove and dispose at completion of the project. APEEL guards the TPO membrane's surface from scuffs and dirt accumulation during installation. If the Contractor does not use the protective film system specified above, the Contractor is responsible to thoroughly clean the roofing membrane surface to the satisfaction of the Architect.

2.03 INSULATION

- A. Provide 20 PSI layers Carlisle InsulBase polyisocyanurate insulation with glass mat facer. Total insulation shall have a minimum "R" value as noted on the drawings meeting the requirements of ASTM C1289 using Long Term Thermal Resistance (LTTR) values.
- B. Protection Board to be Carlisle SecurShield HD Cover Board (Isolation board) (or equal): a rigid insulation panel composed of a high-density, closed-cell polyisocyanurate foam core laminated to moisture resistant coated-glass fiber-mat facer for use as a recover board meeting ASTM 1289-06, Type II, Class 2 (109 psi max). Board is to be a 1/2" thick 4' x 8' panel with a minimum R-value of 2.5. Board is to be mechanically fastened through the insulation into the metal roof deck.
- C. The minimum pitch of all roofing surfaces is to be 1/4" per foot.
- D. All crickets are to be pitched a minimum of 1/2" per foot.)

2.04 ADHESIVES AND CLEANERS

- A. Bonding Adhesive: Low VOC Bonding Adhesive for TPO (To be used as needed): This product meets the <250 gpl VOC (volatile organic compound) content requirements of the OTC Model Rule for Single-Ply Roofing Adhesives. A high strength, solvent-based contact adhesive that allows bonding of TPO membrane to various porous and non-porous substrates. Apply at a rate as recommended by the manufacturer.
- B. Edge Sealant: Cut Edge Sealant
- C. Sealer: Water Cut-Off Mastic
- D. Pocket Sealant: Thermoplastic One-Part Pourable Sealer: A one-part, moisture curing, elastomeric polyether sealant used to fill TPO Molded Pourable Sealant Pockets
- E. Cleaner: Carlisle Weathered Membrane Cleaner
- F. Insulation Adhesive: Sure-Seal FAST 100 Adhesive

2.05 FASTENERS AND PLATES

- A. Carlisle InsulFast fastener: for attachment to wood decks.
(480 lb minimum pull out resistance required, 1.5" minimum deck penetration.
NOTE: fasteners are not allowed to penetrate through deck and be exposed on interior.)
- B. Insulation Fastening Plates: a 3 inch diameter metal plate used for insulation and recover board attachment in conjunction with Carlisle InsulFast Fasteners.
- C. Seam Fastening Plates: a 2 inch diameter metal plate used for additional membrane securement.
- E. Sure-Weld Pressure-Sensitive RUSS™ (Reinforced Universal Securement Strip): a 6" wide, nominal 45-mil thick reinforced TPO membrane with 3" wide Pressure Sensitive Tape laminated along one edge. The 6" wide Pressure-Sensitive RUSS is used horizontally at the base of walls, curbs, etc., in conjunction with 2" diameter Seam Fastening Plates below the TPO deck membrane for additional membrane securement.

2.06 METAL EDGING AND MEMBRANE TERMINATIONS

- A. Carlisle SecurEdge 2000: a metal fascia system with a heavy duty .100" thick extruded aluminum anchor bar and .040 inch thick aluminum fascia. Finish to be Kynar 500 meeting AAMA 2605. Provide 6" high minimum fascia unless noted otherwise on drawings. Metal fascia color is to be selected by Architect from the manufacturer's minimum of 26 standard colors.
- B. Sure-Weld Coated Metal: 4' x 10' coated metal sheets made from 24 gauge galvanized steel with a minimum .035" thick non-reinforced white SureWeld laminate. Sure-Weld membrane can be welded directly to the Sure-Weld Coated Metal in accordance with the manufacturer's detail.
- C. Carlisle Termination Bar: a 1 inch wide and .098 inch thick extruded aluminum bar pre-punched 6 inches on center; incorporates a sealant ledge to support Lap Sealant and provide increased stability for membrane terminations.
Where a termination bar is exposed to view from the ground, provide a Carlisle CB-175F .063 inch termination bar with a CF-175 .040 inch aluminum cover with a factory paint finish. Color selected by Architect from manufacturer's standard colors.
- D. Provide fascia overflow spill-out scuppers in locations shown on drawings.

2.07 WALKWAYS

- A. Carlisle Sure-Weld (or equal) Walkways: Factory-formed, TPO, nonporous, heavy-duty, slip-resisting, surface-textured walkway rolls, approximately 170-mil total thickness and acceptable to roofing system manufacturer. Minimum 34 inches wide. Heat-welded to roof membrane. Ten foot maximum lengths with minimum 1 inch gaps between rolls. Color to be gray. Install in accordance with manufacturer's instructions.

2.08 RELATED MATERIALS

- A. Wood Nailer:
Treated wood nailers shall be installed at the perimeter of the entire roof and around such other

roof projections and penetrations as specified on Project Drawings. Thickness of nailers must match the insulation thickness to achieve a smooth transition and/or insure the top of the new roof edge fascia is level around the roof perimeter. Wood nailers shall be treated for fire and rot resistance (wolmanized or osmose treated) and be #2 quality or better lumber. Creosote or asphalt-treated wood is not acceptable. All wood shall have a maximum moisture content of 19% by weight on a dry-weight basis.

PART 3 - EXECUTION

3.01 GENERAL

- A. Comply with the manufacturer's published instructions for the installation of the membrane roofing system including proper substrate preparation, job site considerations and weather restrictions.
- B. Position sheets to accommodate contours of the roof deck and shingle splices to avoid bucking water.

3.02 EXAMINATION

- A. Verify that roof openings, curbs, pipes, sleeves, ducts, and vents through roof are solidly set, and wood cant strips, wood nailing strips, and reglets are in place.

3.04 PROTECTION

- A. Schedule and execute all work without exposing the building interior to the effects of inclement weather.
- B. Provide suitable barriers to protect the general public.

3.05 INSULATION PLACEMENT

- A. Install insulation over the substrate with boards butted tightly together with no joints or gaps greater than 1/4 inch. Stagger joints both horizontally and vertically if multiple layers are provided.
- B. Secure insulation to the substrate with the required mechanical fasteners in accordance with the manufacturer's specifications.
- C. All sheathing or underlayment that the roofing membrane and flashing is to adhere to shall be compatible with the roofing system and approved by the manufacturer for adhesion. The Contractor is responsible to coordinate and confirm the material is acceptable.

3.06 MEMBRANE PLACEMENT AND ATTACHMENT

- A. Position Sure-Weld SAT membrane over the acceptable substrate.
- B. Fold membrane sheet back so half the underside is exposed.
- C. Remove the release liner on one half of the sheet starting from the split in the liner at the middle of

the sheet. The liner should be removed at an angle to reduce risk of splitting or tearing.

- D. Roll the membrane onto the substrate while avoiding wrinkles. To achieve the best adhesion, the membrane should be rolled onto the substrate at an angle with 30" wide, 150 lb weighted segmented steel roller. When applying the Carlisle Sure-Weld SAT TPO membrane it is recommended to maintain a large curve on the leading edge of the membrane. This will help eliminate creases and bubbles that cannot be removed after the sheet is in place.
- E. Fold back the remaining half of the sheet and repeat the above process.

3.07 MEMBRANE SPLICING/HOT AIR WELDING PROCEDURES

- A. APEEL Protective Film should be removed from within areas that are to be heat-welded together. In areas that do not require heat welding, the APEEL Protective Film should be left in place for up to 90 days.
- B. Heat weld the Sure-Weld membrane sheets together using the Automatic Heat Welder or Hot Air Hand Welder and silicone roller to insure a continuous welded seam in accordance with the manufacturer's instructions.
- C. The surfaces to be heat welded must be clean. Membrane overlaps that become contaminated with field dirt must be cleaned per manufacturer's instructions. No residual dirt or contaminants should be evident.
- D. At all splice intersections, roll the seam with a silicone roller to ensure a continuous hot air welded seam. All splice intersections shall be overlaid with Sure-Weld T-joint covers.
- E. Probe all seams once the hot air welds have thoroughly cooled (approximately 30 minutes).
- F. Repair all seam deficiencies the same day they are discovered.
- G. Apply Cut Edge Sealant on all cut edges of reinforced membrane (where the scrim reinforcement is exposed) after seam probing is complete per manufacturer's instructions. Cut-Edge Sealant is not required on vertical Sure-Weld splices.

3.08 FLASHING

- A. Flashing of parapets, curbs, expansion joints and other parts of the roof must be performed using Sure-Weld reinforced membrane. Sure-Weld non-reinforced membrane can be used for flashing pipe penetrations, Sealant Pockets, and scuppers, as well as inside and outside corners, when the use of prefabricated accessories is not feasible.
- B. Follow manufacturer's typical flashing procedures for all wall, curb, and penetration flashing including metal edging/coping and roof drain applications.

3.09 WALKWAYS

- A. Install walkways at all traffic concentration points (such as around roof hatches, access doors, top & bottom of roof-associated ladders, rooftop mechanical equipment, etc.) and all locations as identified on the contract drawings.

- B. Hot air weld walkway pads to the membrane in accordance with the manufacturer's specifications.

3.10 DRAINS

- A. All drains should be sumped 4' out from center.
- C. Provide flashing per manufacturer's instructions.
- D. Place clamping ring over raised bossed. Install screws to tighten clamping ring against new membrane flashing until secure.
- E. Install and securely fasten strainer dome to complete installation

3.11 DAILY SEAL

- A. On phased roofing, when the completion of flashings and terminations is not achieved by the end of the work day, a daily seal must be performed to temporarily close the membrane to prevent water infiltration.
- B. Complete an acceptable membrane seal in accordance with the manufacturer's requirements.

3.12 CLEANING

- A. Clean work under provisions of Section 01 70 00
- B. Perform daily clean up to collect all wrappings, empty containers, paper, and other debris from the project site. Upon completion, all debris must be disposed of in a legally acceptable manner.
- C. Correct deficiencies in or remove roofing system that does not comply with requirements, repair substrates, and repair or reinstall roofing system to a condition free of damage and deterioration at time of Substantial Completion and according to warranty requirements.
- D. Prior to the manufacturer's inspection for warranty, the applicator must perform a pre-inspection to review all work and to verify all flashing has been completed as well as the application of all sealant.
- E. Upon completion of all new roofing work, remove and dispose of the APEEL Protective Film from the surface of the TPO membrane.
If the Contractor has not used the protective film system noted above, the Contractor is responsible to thoroughly clean the roofing membrane surface to the satisfaction of the Architect.

3.13 PROTECTION OF FINISHED WORK

- A. Protect finished work under provisions of Section 01 70 00.

END OF SECTION

SECTION 07 62 10

ALUMINUM SHEET METAL FLASHING AND TRIM

PART 1 - GENERAL

1.01 SECTION INCLUDES

- A. Metal cladding and trim

1.02 SUBMITTALS

- A. Submit under provisions of Section 01 33 00.
- B. Submit two samples of each of the manufacturer's standard colors for selection by the Architect. Samples are to show the full range of colors available for factory finished aluminum. Samples are to be 2" x 3" minimum, on aluminum of the thickness specified.

1.03 COORDINATION

- A. Coordinate work under provisions of Section 01 31 00.
- B. All sheet metal edging, flashing and trim is to be approved by the roofing system manufacturer to be used in association with their product to maintain the warranty required for the roofing system.

PART 2 - PRODUCTS

2.01 MATERIALS

- A. Aluminum cladding, fascia, trim. Thickness is 0.040".
- B. Finish: Applied Kynar 500/Hylar 5000 in color selected by Architect from manufacturer's standard colors.

2.02 ACCESSORIES

- A. Provide all accessories and fasteners essential to complete the installation of all sheet metal.

PART 3 - EXECUTION

3.01 INSTALLATION

- A. Install all sheet metal work in compliance with SMACNA "Architectural sheet metal manual" recommendations.
- B. All corners shall be mitred.
- C. All sheet metal sections shall be no longer than 12'-0" with expansion joints at 12'-0" maximum intervals. Joints shall be lapped a minimum of 4 inches.

- D. Isolate, as required, all aluminum from direct contact with pressure treated wood, steel, masonry, concrete or other non-compatible materials.

3.02 INTERFACE WITH OTHER PRODUCTS

- A. Coordinate the shape, size and installation of the sheet metal work with the roofing installation.

3.03 CLEANING

- A. Clean work under provisions of Section 01 70 00.
- B. Patch, repair or replace all damaged aluminum due to construction.

END OF SECTION

SECTION 07 62 11

SHEET METAL FLASHING

PART 1 - GENERAL

1.1 SUMMARY

- A. Related Documents:
The Drawings and general provisions of the Contract, including General and Supplementary General Conditions, and Division 1 Requirements, apply to the work in this Section.

1.2 SECTION INCLUDES

- A. Sheet metal work.
B. Custom sheet metal assemblies.

1.3 RELATED SECTIONS

- A. Section 04 73 13 - Natural Thin Veneer Stone
B. Section 07 31 13 - Architectural Roof Shingles
C. Section 07 54 23 - Self-Adhered Thermoplastic Polyolefin Roofing System
D. Section 07 92 13 - Joint Sealants

1.4 PERFORMANCE REQUIREMENTS

- A. General: Sheet metal flashing and trim assemblies shall withstand wind loads, structural movement, thermally induced movement, and exposure to weather without failure due to defective manufacture, fabrication, installation, or other defects in construction. Completed sheet metal flashing and trim shall not rattle, leak, or loosen, and shall remain watertight. Conform to the following requirements:
1. Sheet Metal Standard for Flashing and Trim: Comply with NRCA's "The NRCA Roofing Manual" and SMACNA's "Architectural Sheet Metal Manual" requirements for dimensions and profiles shown unless more stringent requirements are indicated.

1.5 SUBMITTALS

- A. Comply with Division 1 General Requirements and submit for approval:
1. Product Data: Manufacturer's literature including installation instructions, use restrictions and limitations.
 2. Shop drawings: Provide large scale shop drawings for fabrication, installation and erection of all parts of the work. Provide large scale plans, elevations, and details of profiles, joints, seams, anchorages, connections and accessory items. Include statement that materials are physically compatible.
 - a. Field Measurements: Take accurate field measurements before fabrication and indicate same on shop drawings.
 - b. Include attachment details. Identify both shop- and field-assembled work.
 - c. Identify material, thickness, weight, and finish for each item.
 - d. Include details for:
 1. Forming, including profiles, shapes, seams, and dimensions.
 2. Joining, supporting, and securing, including layout and spacing of fasteners, cleats, clips, and other attachments.

3. Termination points and assemblies.
 4. Expansion joints and expansion-joint covers, including showing direction of expansion and contraction from fixed points.
 5. Counterflashings.
 6. Connections to adjoining work.
3. Samples: Submit final samples of selected products. Include samples showing full variation of color and finish expected. Size: 144 square inches or more.
- a. Sheet Metal Flashing: including finished seam and in required profile. Include fasteners, cleats, clips, closures, and other attachments.
 - b. Trim, Metal Closures, Expansion Joints, Joint Intersections, and Miscellaneous Fabrications: In required profile. Include fasteners and other exposed accessories.
 - c. Unit-Type Accessories and Miscellaneous Materials: Full-size Sample.

1.6 QUALITY ASSURANCE

- A. Fabricator Qualifications: Employs skilled workers who custom fabricate sheet metal flashing and trim similar to that required for this Project and whose products have a record of successful in-service performance.
- B. Source Limitations: Obtain materials of a uniform quality, including color for exposed work, from single manufacturer for each component.
 1. Standards: Comply with applicable requirements, recommendations and details of SMACNA Architectural Sheet Metal Manual.

1.7 PRODUCT REQUIREMENTS

- A. Comply with product requirements, delivery storage and handling provisions of Division 1 and the following:
 1. Ensure materials are not adversely affected by galvanic action, or excess differential thermal movement.
 2. Do not store sheet metal flashing and trim materials in contact with other materials that might cause staining, denting, or other surface damage.
 3. Store sheet metal flashing and trim materials away from uncured concrete and masonry.
 4. Protect strippable protective covering on sheet metal flashing and trim from exposure to sunlight and high humidity, except to extent necessary for period of sheet metal flashing and trim installation.

1.6 PROJECT CONDITIONS

- A. Protection: During construction, cover work with waterproof sheeting at end of each day's work. Prevent the intrusion liquid water and the build up of water vapor pressure within assemblies.
- B. Stain Prevention: Prevent grout, mortar, and soil from staining of work be left exposed or painted. Immediately remove grout, mortar, and soil that come in contact with such.

PART 2 - PRODUCTS

2.1 FLASHING & SHEET METAL

- A. Stainless-Steel Sheet: ASTM A 240/A or ASTM A 666, Type 304/Type 316, dead soft, fully annealed; with smooth, flat surface. Provide thicknesses shown, if not as follows:
 - 1. Not otherwise indicated: 0.019 inch.
 - 2. Counterflashing and the like: 0.032 inch.
 - 3. Apron, step flashing, backers: 0.016 inch.
- B. Sheet Aluminum: ASTM B 209, alloy 3003-H14, 0.050 inch thickness minimum. Use for brake metal. All aluminum exposed to view is to have a Kynar 500 factory finish meeting AAMA 2605.

2.2 MISCELLANEOUS MATERIALS

- A. Components include:
 - 1. Fasteners: Match material being fastened for both type of material and finish.
 - 2. Isolation Coating: SSPC paint 12.
 - 3. Slip Sheet: 5 lb. rosin building paper.
 - 4. Plastic Underlayment: 6 mil carbonated polyethylene film, FS L-P-512.
 - 5. Reglets: Metal units of type and profile indicated or required which are compatible with flashings used.
 - 6. Solder: ASTM B 32, as required.
 - 7. Accessories: Provide all clips, cleats, straps, anchors and similar items necessary to properly complete the work. Provide accessories that are compatible with sheet metal materials used and which are of sufficient size and gage to perform as intended.
 - 8. Elastomeric Sealant: ASTM C 920, elastomeric polyurethane or silicone polymer sealant; of type, grade, class, and use classifications required to seal joints in sheet metal flashing and trim and remain watertight.
 - 9. Butyl Sealant: ASTM C 1311, single-component, solvent-release butyl rubber sealant; polyisobutylene plasticized; heavy bodied for hooked-type expansion joints with limited movement.
 - 10. Bituminous Coating: Cold-applied asphalt emulsion according to ASTM D 1187.
 - 11. Asphalt Roofing Cement: ASTM D 4586, asbestos free, of consistency required for application.

2.3 FABRICATION

- A. Shop fabricate work to the greatest extent possible. Fabricate work to be truly straight, plumb, level and square, and to provide the best possible watertight, weatherproof performance with expansion provisions in running work.
- B. Provide work to sizes, shapes, and profiles indicated on approved shop drawings. Comply with referenced standards. Minimize oil-canning, buckling, tool marks and other defects.
- C. Make work with uniform, watertight joints. Make seams as inconspicuous as possible.
- D. Isolate dissimilar materials with isolation coating or other permanent separation acceptable to the Architect.

PART 3 - EXECUTION

3.1 EXAMINATION

- A. Examine and verify conditions as follows:
 - 1. Verify substrates and underlying work is within tolerances specified.
 - 2. Verify structural components are properly placed.
 - 3. Proceed with installation only after unsatisfactory conditions have been corrected.

3.2 TOLERANCES

- A. For exposed work, the following allowable installed tolerances are allowable variations from locations and dimensions indicated by the Contract Document and shall not be added to allowable tolerances indicated for other work.
 - 1. Allowable Variation from True Plumb, Level, and Line: +/- 1/8" in 20'-0"
 - 2. Allowable Variation from True Plane of Adjacent Surfaces: +/- 1/16"

3.3 INSTALLATION

- A. Install flashing in continuous uninterrupted manner to accomplish 'intent' complete with all transitions, laps, splices, folds, seams necessary to ensure the diversion of water to the exterior. Work in close coordination with installation of exterior masonry, roofing, window, joint sealer, louver, and the like.
 - 1. Apply materials within manufacturer's requirements for temperature and weather conditions.
 - 2. Do not apply to wet or frozen substrates.
 - 3. Do not allow contamination with dust or dirt.
 - 4. Seal completely at edges, perimeter and penetrations.
- B. Strictly comply with manufacturer's instructions and recommendations and standard details and recommendations of SMACNA, except where more restrictive requirements are specified in this section. Locked and sealant locked joints as indicated on the Drawings.
- C. Securely anchor work, but allow for thermal movement and building movement. Use concealed fasteners to the greatest extent possible. Install work to be permanently weatherproof and watertight. Provide continuous cleats at all edge conditions.
- D. Provide reglets where indicated and where required. Coordinate installation with related and adjacent work.
- E. Expansion Provisions: Provide for thermal expansion of exposed flashing and trim. Space movement joints at maximum of 10 feet with no joints within 24 inches of corner or intersection.
 - 1. Form expansion joints of intermeshing hooked flanges, not less than 1 inch deep, filled with sealant concealed within joints.
 - 2. Use lapped expansion joints only where indicated on Drawings.
- F. Fasteners: Use fastener sizes that penetrate wood or sheathing substrate not less than 1-1/4 inches for nails and not less than 3/4 inch for wood screws and for other substrates not less than recommended by fastener manufacturer to achieve maximum pull-out resistance.
- H. Provide flashing at every obstruction to the downward flow of water. Design and install

flashing to control and divert water to the exterior. Form at least 4" high end pans above lintels and similar conditions to extend the entire length of the lintel where possible. Flashing shall extend 4" minimum beyond end of lintel before it is panned (dammed).

3.4 CLEAN UP & PROTECTION

- A. Adjust work to conform to specified tolerances and appear uniform, straight and correct. Touch-up damaged coatings and finishes to eliminate evidence of repair.
 - 1. Repair minor damage to eliminate all evidence of repair. Remove and replace work which cannot be satisfactorily repaired.
 - 2. Clean exposed surfaces using materials and methods recommended by manufacturer of material or product being cleaned. Remove and replace work that cannot be successfully cleaned.

END OF SECTION

THIS PAGE INTENTIONALLY LEFT BLANK

SECTION 07 65 26

THROUGH WALL FLASHING MEMBRANE SYSTEM.

PART 1: GENERAL

1.01 SUMMARY

- A. Section includes materials and installation methods of through-wall flashing membrane system.
- B. Related Sections:
 - 1. 04 73 13 - Natural Thin Veneer Stone
 - 2. 07 21 13 - Board Insulation

1.02 REFERENCES

- A. The following standards are applicable to this section:
 - 1. ASTM E96: Water Vapor Transmission of Materials.
 - 2. CGSB 37-GP-56M: Membrane, Modified, Bituminous, Prefabricated, and Reinforced.

1.03 SYSTEM DESCRIPTION

- A. Provide a continuous air and vapor barrier system where indicated.

1.04 SUBMITTALS

- A. Submit shop drawings and product data under provisions of Section 01 33 00.
- B. Prior to commencing the Work, submit manufacturer's product data, samples and a complete set of standard details for the through-wall flashing membrane system.

1.05 QUALITY ASSURANCE

- A. Perform Work in accordance with the manufacturer's requirements and this specification.
- B. Maintain one copy of manufacturer instructions on site.

1.06 DELIVERY, STORAGE AND HANDLING

- A. Protect products under provisions of Section 01 60 00.
- B. Deliver materials to the job site in undamaged and original packaging indicating the name of the manufacturer and product.
- C. Store materials on end in original packaging.
- D. Store membranes, adhesives and primers at temperatures between 40°F and 110° to facilitate handling.
- E. Keep solvent away from open flame or excessive heat.

- F. Protect rolls from direct sunlight until ready for use.

1.07 PROJECT CONDITIONS

- A. Perform Work only when conditions are acceptable to the manufacturer of the materials being installed.
- B. Ensure all preparation work is complete prior to installing through-wall flashing membrane system.

1.08 COORDINATION

- A. Ensure continuity of the through-wall flashing system throughout the scope of this section.

PART 2: PRODUCTS

2.01 MANUFACTURER

- A. Henry Company
- B. Other acceptable manufacturers offering equivalent products:
 - 1. Carlisle
 - 2. Tremco
- C. Substitutions: Under provisions of Section 01 60 00.

2.02 MATERIALS

- A. Through-wall flashing membrane (Self-Adhering):
 - 1. **Blueskin® TWF** as manufactured by Henry, a SBS modified bitumen, self-adhering sheet membrane complete with a cross-laminated polyethylene film, having the following physical properties:
 - a. Thickness: 0.0394" (40 mils).
 - b. Film Thickness: 9.0 mils
 - c. Puncture Resistance (film): 40lbf to ASTM E154;
 - d. Tensile Strength (film): 5000 psi ASTM D882
 - e. Tear Resistance: 13lb in MD to ASTM D1004;
 - f. Low temperature flexibility: -30°C to CGSB 37-GP-56M;
- B. Membrane Primer selected from following materials as recommended by manufacturer:
 - 1. **Blueskin® Primer** as manufactured by Henry, a synthetic rubber based adhesive, quick setting.
 - 2. **Aquatac Primer** as manufactured by Henry, a polymer emulsion based adhesive.

PART 3: EXECUTION

3.01 EXAMINATION

- A. Verify that surfaces and conditions are ready to accept the Work of this section. Notify contractor in writing of any discrepancies. Commencement of the work or any parts thereof shall mean acceptance of the prepared substrate.

3.02 PREPARATION

- A. All surfaces must be sound, dry, clean and free of oil, grease, dirt, excess mortar or other contaminants. Fill spalled areas in substrate to provide an even plane.
- B. New concrete should be cured for a minimum of 14 days and must be dry before membranes are applied.

3.03 INSTALLATION

- A. Primer for Through-wall Flashing Membrane (Self-Adhering Type only)
 - 1. Apply primer to all areas to receive through-wall flashing membrane, as indicated on drawings, by roller or spray and allow minimum 30 minute open time. Primed surfaces not covered by through-wall flashing membrane during the same working day must be re-primed.
- B. Metal drip edge flashing
 - 1. Metal drip edge is fabricated from stainless steel meeting ASTM A167 Type 304 in 26 gage thickness. Place the Drip Edge on the steel angle or concrete, separate the stainless steel from the carbon steel with a non-absorbing separation material. Seal metal drip edge in place. Install the Blueskin® TWF Flashing over the metal drip edge and seal the contact area.
- C. Through-wall Flashing Membrane (Self-Adhering Type)
 - 1. Align and position the leading edge of Blueskin® TWF self-adhering through-wall flashing membrane with the front horizontal edge of the foundation walls or shelf angles, partially remove protective film and roll membrane over surface and up vertically.
 - 2. Press firmly into place. Ensure minimum 2" overlap at all end and side laps.
 - 3. Promptly roll all laps and membrane to effect the seal.
 - 4. Ensure through-wall flashing membrane extends fully to the exterior face of the exterior masonry veneer. Trim off excess at the face of the masonry veneer.
 - 5. At all laps, seams, penetrations, and along top edges of Blueskin® TWF, apply a continuous bead of rubberized mastic such as Air-Bloc or POLYBITUME® 570-05. Form end dams as required and use rubberized mastic at laps.
 - 6. Apply through-wall flashing membrane along the base of masonry veneer walls, over windows, doors and all other wall openings. Membrane shall form continuous flashing and shall extend a minimum of 8" up the back-up wall.

3.04 PROTECTION OF FINISHED WORK

- A. Non-resistant to oils and solvents not designed for permanent exposure. Yellow surface film may release on extended exposure to U.V. Good practice calls for covering as soon as possible. Do not extend Blueskin® TWF beyond face of exterior wall or veneer. Avoid sealant contact with the underside (compound side) of Blueskin® TWF.

3.05 CLEANING

- A. Clean work under provisions of Section 01 70 00.
- B. All waste materials shall be disposed of properly and in accordance with all Federal, State, and Local regulations.

END OF SECTION

SECTION 07 71 23

GUTTERS AND DOWNSPOUTS

PART 1 - GENERAL

1.01 SUMMARY

- A. Related Documents:
The Drawings and general provisions of the Contract, including General and Supplementary General Conditions, and Division 1 Requirements, apply to the work in this Section.

1.02 SECTION INCLUDES

- A. Provide labor, material, and equipment necessary for furnishing a complete installation of a commercial gutter and downspout system.

1.03 RELATED SECTIONS

- A. Section 07 31 13 -Architectural Roof Shingles
- B. Section 07 92 13 - Joint Sealants

1.04 REFERENCES

- A. Sheet Metal and Air Conditioning Contractors National Association (SMACNA)

1.05 SUBMITTALS

- A. Submit under provisions of Section 01 33 00.
- B. Product Data: Each type of product specified. Submit manufacturer's detailed technical product data, installation instructions and recommendations, dimensions of individual components, profiles, and finishes
- C. Shop Drawings: Show fabrication and installation of commercial gutter system including fully dimensioned roof plans, expansion joint locations, sections and details of components and other related trims.
- D. Finish & Color Selection: Furnish manufacturer's technical data for specified finish and color chart showing full range of colors available.

1.06 QUALITY ASSURANCE

- A. Obtain all components and related accessories from one single source manufacturer.
- B. Follow manufacturer's printed instructions for installing commercial gutter system. Follow primary roofing manufacturer's printed instructions for installing associated roof material for flashing gutter system to roof.

1.07 DELIVERY, STORAGE & HANDLING

- A. Deliver, store, protect and handle products to site under provisions of Section 01 60 00.
- B. All products delivered shall be stored in a clean dry location prior to installation.
- C. Products furnished with strippable protective masking shall not be exposed to direct sunlight for more than 30 minutes without removing masking.
- D. Do not install finished materials with scars or abrasions.

1.08 PROJECT CONDITIONS

- A. Coordinate work of this Section with adjoining work for proper sequencing to ensure protection from inclement weather and to protect materials and their finish against damage.
- B. Do not install commercial gutter system during inclement weather. When installing in cold climates, warm adhesives, caulks, and primers to at least 50 degrees Fahrenheit prior to application.

PART 2 - PRODUCTS

2.02 MATERIALS

- A. Gutters: Provide seamless gutters.
Manufactured in a uniform section with matching corner units, end caps, outlet tubes, and other accessories as required for a complete system.
Elevate back vertical edge at least 1 inch higher front edge.
Furnish expansion joints and expansion-joint covers fabricated from same metal as gutters.
 - 1. Fabricate from the following exposed metal:
 - a. Formed Aluminum: 0.032 inch
 - 2. Gutter Profile: Style D (rectangular) according to SMACNA's "Architectural Sheet Metal Manual."
 - 3. Gutter size: 6" width at top.
 - 4. Corners: Factory mitered and mechanically clinched and sealed watertight.
 - 5. End caps to be 0.024" gauge
 - 6. Gutter Supports: Internal concealed straps manufactured from 0.125" x 1.00" aluminum or approved hangers.
 - 7. Support Bracket: Shall be manufactured from 0.125" x 1.00" aluminum, factory punched for fasteners. (Optional)
 - 8. Gutter Accessories: Provide continuous leaf guard. Manufacturer: LeafFilter (or approved equal)
- B. Downspouts: Plain rectangular complete with machine-crimped elbows, manufactured from the following exposed metal.
 - 1. Formed Aluminum: 4"x5" and 0.032 inch thick..
 - 2. Finish to match gutter.
 - 3. Downspouts to be one continuous unit without joints.
 - 4. Outlets: At all downspout locations provide aluminum outlets to connect liner to downspout.

5. Wall Brackets: Provide wall brackets at 60" maximum spacing (minimum 2 brackets). Brackets shall be manufactured from 0.125" x 1.00" aluminum, finished to match downspout.

2.03 ACCESSORIES

- A. Nails: Aluminum nails of 5056 or 6110 alloy having a minimum tensile strength of 63,000 psi. All nails shall have a suitable etch finish to remove greases and provide additional holding power.
- B. Liner Expansion Joint: Provide manufacturer's elastomeric expansion joints with cover plates at 40' intervals or as shown on shop drawings.
- C. Sealant: Shall be polyurethane or silicon based water-proofing type, compatible with aluminum gutter, downspout, and abutting dissimilar materials for intended application.
- D. All accessories designed for use with the gutters and downspouts are to have the same finish.

2.04 FINISHES

- A. Exterior coating to be a High Performance Coating, two-coat, shop applied, 70% Polyvinylidene Fluoride (PVDF) coating based on Elf Arkema Chemicals, Inc. Kynar 500 or Ausimont U.S.A., Inc. Hylar 5000 resin, meeting AAMA 2605 specification. Color as selected by Architect from manufacturer's standard colors.
- B. Interior coating to be a corrosion inhibiting finish.

PART 3 - EXECUTION

3.01 PREPARATION

- A. Verify governing, dimensions at building; examine, clean and repair, if necessary, any adjoining work on which this work is in any way dependent for its proper installation.
- B. Provide and install quantity of downspouts required to accommodate the rainfall at the rate of 1,200 sq. ft. of roof area on the horizontal maximum per downspout.

3.02 INSTALLATION

- A. Install gutter using hangers so that movement is not restricted.
- B. Gutter hangers shall be installed a maximum of 32" on center and nailed to the roof sheathing or fascia board at rafter locations. Nails shall be 1-1/2" aluminum screw shank nails.
- C. Gutters shall not have seams in lengths 40 feet and under.
- D. Provide expansion joints on all sides of a hip roof and on runs of more than forty feet in length.
- E. Pitch gutters down toward downspouts at 1/16" per foot minimum.
- F. Dissimilar materials shall receive a protective coating as required.

- G. Gutters shall support a minimum of 50 pounds per linear foot installation.
- H. Install interior straps by fully engaging them into gutter's hemmed edge, complete by securely riveting.
- I. Rivet and seal liner joints with high grade exterior sealant.
- J. All downspouts shall empty into a storm drainage system, provide connecting boots of the proper material and style required to coordinate with site work components.

3.03 CLEANING

- A. Clean work under provisions of Section 01 70 00.
- B. Clean all aluminum surfaces
- C. All scrap materials shall disposed off-site.

3.04 PROTECTION OF FINISHED WORK

- A. Protect finished work under provisions of Section 01 70 00.

END OF SECTION

SECTION 07 72 00

ROOF ACCESSORIES

PART 1 - GENERAL

1.01 SECTION INCLUDES

- A. Furnish and install roof accessories and all associated components as outlined in this specification section.

1.02 RELATED SECTIONS

- A. Work specified elsewhere including, but not limited to, the furnishing and installing of the roofing system, wood nailers, flashings, and vapor barrier as occurring.

1.03 SUBMITTALS

- A. Submit under provisions of Section 01 33 00.
- B. Product Data: Provide data on product materials, characteristics, performance criteria, limitations and durability.
- C. Samples: Provide as requested by Architect.
- D. Manufacturer's installation instructions submitted indicating preparation required and installation techniques.
- E. Submit Material Safety Data Sheets for all liquid, paste or gaseous components.
- F. Submit shop drawings including standard detail drawings of product and recommended layout drawings.

1.04 QUALITY ASSURANCE

- A. Regulatory requirements: Conform to all applicable Local and State Codes.

1.05 QUALIFICATIONS

- A. Manufacturer: Company specializing in manufacturing the products specified in this section must have a minimum of five years documented experience.
- B. Installer: Company specializing in performing the work of this section must have a minimum of five years documented experience.

1.06 DELIVERY, STORAGE, AND HANDLING

- A. Deliver, store, and handle products under provisions of Section 01 60 00.

1.07 PROJECT/SITE CONDITIONS

- A. Roof surface shall be free of ponded water, snow or ice.

1.08 FIELD MEASUREMENTS

- A. Verify that field measurements are as indicated on drawings.

1.09 COORDINATION

- A. Coordinate and schedule installation of accessories with related work of other sections such as flashing, wood nailers, roofing system and vapor barrier as occurring.

1.10 WARRANTY

- A. Provide warranty under provisions of Section 01 78 00.

PART 2 - PRODUCTS

2.01 PRODUCTS

A. New Roof Drain

1. Aluminum Classic Drain manufactured by OMG Roofing Products
 - a. Drain Body:
 1. Manufactured from 11 gauge (.125") spun aluminum
 2. Flange includes six aluminum studs
 3. Depressed sump area
 - b. Strainer Dome:
 1. Made of cast aluminum
 2. Height – 7.25"
 3. Outside base diameter – 9.77"
 - c. Clamping Ring:
 1. Made of cast aluminum
 2. Gravel stop height – 1.2"
 3. Drainage slots – 18 "V" shaped
 4. Six bosses to accept studs on flange
 - d. Connector:
 1. Provide no-hub coupler with stainless steel bands to connect drain stem to building drain pipe.
 - e. Nuts and Screws:
 1. Six stainless steel locknuts for the studs
 2. Three stainless steel screws to attach strainer to clamping ring
 - f. Provide size as required to connect with new drain pipe and provide a watertight connection. Verify at site.

- B. Substitutions: Under provisions of Section 01 60 00.

PART 3 - EXECUTION

3.01 INSPECTION AND ACCEPTANCE

- A. Inspect all surfaces to receive work of this section. Correct any defects affecting installation.

3.02 INSTALLATION

- A. Install all products in accordance with manufacturer's instructions and requirements.

3.03 CLEANING

- A. Clean work under provisions of Section 01 70 00.
- B. Remove all debris from roof upon completion of installation and dispose in accordance with all applicable codes and laws.

END OF SECTION

THIS PAGE INTENTIONALLY LEFT BLANK

SECTION 07 84 13

FIRESTOPPING

PART 1 – GENERAL

1.01 SUMMARY

- A. Related Documents:
The Drawings and general provisions of the Contract, including General and Supplementary General Conditions, and Division 1 Requirements, apply to the work in this Section.

1.02 RELATED SECTIONS

- A. Division 21 – Fire Suppression
B. Division 22 - Plumbing
C. Division 23 – Mechanical
D. Division 26 – Electrical

1.03 DESCRIPTION OF WORK

- A. The work of this Section consists of the provision of all plant, materials, labor and equipment and the like necessary or required for the complete execution of all firestopping and smoke seal work for this project as required by the schedules, keynotes and drawings, including, but not limited to the following:

NOTE – Firestopping is defined as a material, or combination of materials, to restore the integrity of fire rated walls and floors by maintaining an effective barrier against the spread of flame, smoke and toxic gases.

1. Provide firestopping and smoke seals as indicated on the drawings and as required to maintain full and continuous smoke and fire barrier between zones.

Seal all penetrations between floor/ceiling plane with expanding foam. No fiber insulation packing is permitted.

Cope and seal around all structural elements to insure smoke and fire barriers.

2. Provide firestopping of all openings in floors and walls both empty and those accommodating penetrating items such as cables and wires, cable trays, conduits, pipes, ducts, etc.; coordinate with Divisions 21, 22, 23 and 26.
3. Provide firestopping at joints between curtain walls and floor or roof openings and balance of openings between exterior walls and connecting floor assemblies at each floor.
4. Pack expansion joints in fire rated walls and floors;
5. Provide firestopping of openings at each floor level in shafts or stairwells.

1.04 REFERENCE STANDARDS

- A. American Society for Testing and Materials (ASTM)
 - 1. E 814 – Standard Method of Fire Tests of Through Penetration Fire Stops.
 - 2. E 119 – Methods of Fire Tests of Building construction and Materials.
 - 3. E 84 – Standard Test Method for Surface Burning Characteristics of Building Materials.

- B. Underwriters Laboratories, Inc. (UL)
 - 1. UL 1479 – Fire Tests of Through Penetration Fire Stops.
 - 2. UL 263 – Fire Tests of Building Construction and Materials.
 - 3. UL 723 – Surface Burning Characteristics of Building Materials.
 - 4. UL “Fire Resistance Directory” current year.

- C. Factory Mutual (FM) Approval Guide, current year.

- D. Building code o the jurisdiction of the work.

- E. National Fire Protection Association
 - 1. NFPA 101 – Life Safety Code.
 - 2. NFPA 70 – National Electrical Code.

1.05 QUALITY ASSURANCE

- A. Firestopping materials shall conform to both Flame (F) and Temperature (T) ratings as tested by nationally accepted test agencies per ASTM E 814 or UL 1479 fire tests.

The F rating and T rating must be a minimum of 1 hour but not less than the fire resistance rating of the assembly being penetrated.

The fire test shall be conducted with a minimum positive pressure differential of 0.03 inches of water column.

- B. Firestopping shall be performed by a Specialty Contractor trained or approved, in writing, by firestop material manufacturer.
Said specialist shall be as defined in the conditions.

Equipment used shall be in accordance with firestop material manufacturer's written installation instructions.

- C. Materials shall conform to all applicable governing codes.

- D. All materials used in the work shall be certified “asbestos free” and shall be free from any and all solvents or components that require hazardous waste disposal or, that after curing, dissolve in water.

- E. All materials shall comply with the interior finish flame spread and smoke developed requirements for the area in which they are installed. Coordinate with governing codes.

1.06 SUBMITTALS

- A. Submit under provisions of Section 01 33 00.
- B. Certification of specification compliance of all materials.
- C. Manufacturer's printed product data and drawings indicating product characteristics, performance, detail applications and limiting criteria.

Submittal shall include applicable UL and/or FM assembly numbers for each material and proposed installation.

- D. Manufacturer's installation instructions for each type of firestop required by the project.
- E. Manufacturer's approval of nominated installer of firestopping and smoke seal products.
- F. Mockups:
 - 1. Prepare job mockup of the material proposed for use in the project as directed by Architect.
Approved markups shall be left in place as part of the finished project and will constitute and standard for remaining work, including aesthetics.
- G. Manufacturers Material Safety Data Sheet (MSDS) must be submitted for each manufactured product.

1.07 PRODUCT DELIVERY STORAGE AND HANDLING

- A. Deliver, store, protect and handle products to site under provisions of Section 01 60 00.
- B. Deliver all materials to be used in the work of this section to the project site in original sealed containers with manufacturer's brand and name, lot numbers, UL labeling, mixing and installation instructions clearly identified thereon.
- C. Store all materials in accordance with manufacturer's directions.

All materials shall be dated with shelf life and shall be removed from the project site at the contractor's expense if date is expired.

1.08 PROJECT CONDITIONS

- A. Conform to manufacturer's printed instructions for installation and when applicable, curing in accordance with temperature and humidity. Conform to ventilation and safety requirements.
- B. Coordinate work required with work of other trades; firestopping shall, where practical, precede gypsum board or other applied sheet finishing operations.
- C. Where firestopping is installed at locations which will remain exposed in the finished work, provide protection as necessary to prevent damage to adjacent surfaces and finishes, and protect as required against damage from other construction operations.

- D. Adhesive and sealants use in the building interior [i.e., inside the exterior moisture barrier] shall not exceed VOC content limits of:
 - 1. Provisions of 01 81 10 Environmental Impact of Materials.
 - 2. Aerosol Adhesives: Green Seal Standard GC-36.

1.09 PREINSTALLATION CONFERENCE

- A. A preinstallation conference shall be scheduled in accordance with Section 01 31 00 by the contractor with this specialty contractor and all other specialty contractors, subcontractor and the like to establish procedures to maintain optimum working conditions and to coordinate the work of this section with related and adjacent work.

1.10 COORDINATION

- A. Coordinate construction of openings and penetrating items to ensure that through-penetration firestop systems are installed according to specified requirements, and comply with the following:
 - 1. Coordinate work of this section with similar work being performed by certain trades for their own work.
 - 2. All firestop work not performed by trades shall be performed under this section.
 - 3. Coordinate sizing of sleeves, openings, core-drilled holes, or cut openings to accommodate through-penetration firestop systems.
 - 4. Notify the Architect at least seven days in advance of through-penetration firestop system installations; confirm dates and times on days preceding each series of installations.
 - 5. Do not cover up through-penetration firestop system installations that will become concealed behind other construction until the Architect and building inspector, if required by authorities having jurisdiction, have examined each installation.

PART 2 – PRODUCTS

2.01 SPECIFICATION STANDARD: For purposes of establishing standards of quality and levels of performance and not for the purposes of limiting competition, the basis of this specification is upon units as manufactured by one of the following and their respective model suitable for the intended application.

- A. Bio Fireshield, Inc.; Damonmill Square, Concord, MA 01742.
 - 1. Novasit K-10 Firestop Mortar
 - 2. K-2 Firestop Mortar
 - 3. Biotherm Firestop Sealants and Caulk
 - 4. Firestop Sleeve
 - 5. Firestop Pillows
 - 6. Biostop 500 Intumescent Caulk

- B. IPC Corp.
 - 1. KBS Mortar Seal
 - 2. Flamesafe Sealants and Caulk
 - 3. FPS 1000 Putty and 1077 Putty Pads
 - 4. Firestop Kits – FSK200
 - 5. KBS Seal Bags
 - 6. Quelpyre Tapes and Blankets

- C. Dow Corning
 - 1. Firestop Sealant #2000
 - 2. Firestop Foam #2001

- D. 3M Corporation
 - 1. Fire Barrier Caulk, CP-25WB
 - 2. Fire Barrier MPS-2 Putty and 4S Putty Pads
 - 3. Fire Barrier Intumescent Wrap Strip #FS-195

- E. Nelson Firestop Products
 - 1. FSP Firestop Putty
 - 2. CMP Firestop Compound
 - 3. CLK Firestop Sealant
 - 4. PLW intumescent Pillow
 - 5. PCS Preformed Collar for Plastic Pipe Penetrations
 - 6. MPS Multi-Plug
 - 7. MCT Multi-Cable Transit
 - 8. EMCT Multi-Cable Transit and Plug
 - 9. CTG Firestop Coating
 - 10. CPS Composite Sheet

- F. Tremco, Inc.
 - 1. Fyre-Sil and Fyre-Sil SL
 - 2. Fyre-Shield
 - 3. THC-900/901
 - 4. Dymeric, Dymonic Sealant Systems
 - 5. Compatible forming systems.

- G. General Electric
 - 1. Pensil 100 Sealant
 - 2. Pensil 200 Foam
 - 3. Pensil 300 Joint Sealant
 - 4. Pensil 500 Putty
 - 5. Compatible forming systems.

- H. U.S. Gypsum Company
 - 1. U.S.G. "Thermafiber" unfaced safing insulation with third party wrap, 3.5 pcf density, UL R-10905 label.
 - 2. U.S.G. "Firecode" compound.

- I. Hilti Corporation
 - 1. Hilti CP 645 insulated firestop sleeve to replace existing pipe insulation

2.02 ACCESSORY ELEMENTS

- A. Forming, damming materials shall be mineral fiber board or other suitable material recommended by nominated system manufacturer.

- B. Primers, sealant and solvent cleaners shall be as recommended by the nominated system manufacturer.
- C. Metal Systems – 20 gauge phosphatized, electrogalvanized steel plate or galvanized steel clips.

PART 3 – EXECUTION

3.01 INSPECTION AND ACCEPTANCE

- A. Examine all surfaces and contiguous elements to receive work of this section and correct, as part of the work of this contract, any defects affecting installation.
- B. Commencement of work will be construed as complete acceptability of surfaces and contiguous elements.

3.02 PREPARATION

- A. The surface shall be dry, clean, and free of all foreign matter.
- B. Do not apply firestopping to surfaces previously painted or treated with a sealer, curing compound, water repellent or other coatings unless tests have been performed to ensure compatibility of materials.
- C. Provide primers as required which conform to manufacturer's recommendations for various substrates and conditions.
- D. Mask where necessary to protect adjoining surfaces.
- E. Remove excess material and stains on surfaces as required.

3.03 INSTALLATION – GENERAL SYSTEMS

- A. Install in strict accordance with manufacturer's printed instructions.
- B. Ensure that anchoring devices, backup materials, clips, sleeves, supports and other materials used in the actual fire test are installed.
- C. Install firestopping with sufficient pressure to properly fill and seal openings to ensure an effective smoke seal.
- D. Tool or trowel exposed surfaces. Remove excess firestop material promptly as work progresses and upon completion.
- E. Install dams when required to properly contain firestopping materials within openings and as required to achieve required fire resistance ratings. Combustible damming materials must be removed after appropriate curing. Incombustible damming materials may be left as a permanent component of the firestopping systems.

- 3.04 FIRESTOPPING CONSTRUCTION AT BUILDING EXTERIOR PERIMETERS, INTERIOR WALLS, SHAFTS, ETC.
- A. Install material of proper size on continuous plates or clips as required for proper support in order to safe-off area between exterior walls, interior walls and shafts and floor slabs, said walls and roof areas leaving NO VOIDS.
 - B. Firestopping is required at all juncture conditions whether or not clips, angles or other structural elements exist either intermittently or continuously.
 - C. Attach plates and clips to floor levels and other breaks and extend through framing to sheathing or other solid strata.
 - D. Where metal decking flutes, either parallel or perpendicular to walls, occur and are open, same shall be fully packed and sealed with proper firestopping system.
 - E. Where firestopping is accomplished after installation of drywall or other applied sheet finish, all spaces between penetrations and finish shall be filled to the thickness of said sheet finish with intumescent caulk.
 - F. At all linear openings, fill voids with a minimum of 6 inches of minimum 3.5 lb./cu. ft. density safing insulation as specified in Part 2 herein and cover entire surface with UL listed firestop sealant of one of nominated manufacturers identified in Part 2 herein.

3.05 PENETRATION SEALS

- A. Penetrations are defined as conduits, cables, wires, piping, ducts or other elements passing through one through one or both outer surfaces of fire rated walls, floors or partitions and shall be firestopped on both sides of penetration in accordance with requirements set forth in Paragraph 1.04 of this Section.
- B. Where sleeves are used, same shall be as specified in Part 2 herein; in event that sleeves are not used, core openings and caulk penetrating items with intumescent system the full length of penetration and seal on both sides with intumescent caulk.
- C. Residual openings within square or rectangular holes shall be filled with compounds applicable for substrate encountered and all penetrations sealed on both sides with caulk.
- D. Where existing pipes penetrate new partition, replace existing pipe insulation with new insulated firestop sleeve and seal perimeter of remaining opening on both sides with caulk.

3.06 FIELD QUALITY CONTROL

- A. Contractor shall immediately notify the Architect if the firestopping systems herein specified cannot meet the requirements of the specification.
- B. Contractor shall examine firestops to ensure proper installation and full compliance with this specification.
- C. All areas of work must be accessible until inspection by the applicable code authorities.

- D. Correct unacceptable firestops and provide additional inspection to verify compliance with this specification at no additional cost.

3.07 CLEANING

- A. When finished work will be visible, clean adjacent surfaces in accordance with manufacturer's printed instructions.
- B. If visible in the finished work, remove temporary dams after initial cure of firestops.
- C. Correct staining and discoloring on adjacent surfaces.
- D. Remove all debris and excess materials entirely from site and leave work in a neat and clean condition.

END OF SECTION

SECTION 07 92 13

JOINT SEALANTS

PART 1 - GENERAL

1.1 RELATED DOCUMENTS

- A. Drawings and general provisions of the Contract, including General and Supplementary Conditions and Division 01 Specification Sections, apply to this Section.

1.2 SUMMARY

A. Section Includes:

1. Silicone joint sealants.
2. Urethane joint sealants.
3. Acoustical joint sealants.

B. Related Sections:

1. Division 04 Section "Unit Masonry" for masonry control and expansion joint fillers and gaskets.
2. Division 08 Section "Glazing" for glazing sealants.
3. Division 09 Section "Gypsum Board" for sealing perimeter joints.
4. Division 09 Section "Tiling" for sealing tile joints.

1.3 PRECONSTRUCTION TESTING

- A. Preconstruction Compatibility and Adhesion Testing: Submit to joint-sealant manufacturers, for testing indicated below, samples of materials that will contact or affect joint sealants.

1. Use ASTM C 1087 to determine whether priming and other specific joint preparation techniques are required to obtain rapid, optimum adhesion of joint sealants to joint substrates.
2. Testing will not be required if joint-sealant manufacturers submit joint preparation data that are based on previous testing, not older than 24 months, of sealant products for adhesion to, and compatibility with, joint substrates and other materials matching those submitted.

1.4 SUBMITTALS

- A. Submit under provisions of Section 01 33 00.
- B. Product Data: For each joint-sealant product indicated.
- C. Samples for Initial Selection: Manufacturer's color charts consisting of strips of cured sealants showing the full range of colors available for each product exposed to view.

- D. Joint-Sealant Schedule: Include the following information:
 - 1. Joint-sealant application, joint location, and designation.
 - 2. Joint-sealant manufacturer and product name.
 - 3. Joint-sealant formulation.
 - 4. Joint-sealant color.
- E. Product Certificates: For each kind of joint sealant and accessory, from manufacturer.
- F. Product Test Reports: Based on evaluation of comprehensive tests performed by a qualified testing agency, indicating that sealants comply with requirements.
- G. Preconstruction Compatibility and Adhesion Test Reports: From sealant manufacturer, indicating the following:
 - 1. Materials forming joint substrates and joint-sealant backings have been tested for compatibility and adhesion with joint sealants.
 - 2. Interpretation of test results and written recommendations for primers and substrate preparation needed for adhesion.

1.5 QUALITY ASSURANCE

- A. Installer Qualifications: Manufacturer's authorized representative who is trained and approved for installation of units required for this Project.
- B. Mockups: Install sealant in mockups of assemblies specified in other Sections that are indicated to receive joint sealants specified in this Section. Use materials and installation methods specified in this Section.
- C. Deliver, store, protect and handle products to site under provisions of Section 01 60 00.

1.6 PROJECT CONDITIONS

- A. Do not proceed with installation of joint sealants under the following conditions:
 - 1. When ambient and substrate temperature conditions are outside limits permitted by joint-sealant manufacturer or are below 40 deg F.
 - 2. When joint substrates are wet.
 - 3. Where joint widths are less than those allowed by joint-sealant manufacturer for applications indicated.
 - 4. Where contaminants capable of interfering with adhesion have not yet been removed from joint substrates.

1.7 WARRANTY

- A. Warranty Period: Two years from date of Substantial Completion. Provide under the provisions of Section 01 78 00.

PART 2 - PRODUCTS

2.1 MANUFACTURERS

- A. Manufacturers as listed below

- B. Substitutions: Under provisions of Section 01 60 00.

2.2 MATERIALS, GENERAL

- A. Compatibility: Provide joint sealants, backings, and other related materials that are compatible with one another and with joint substrates under conditions of service and application, as demonstrated by joint-sealant manufacturer, based on testing and field experience.
- B. VOC Content of Interior Sealants: Provide sealants and sealant primers for use inside the weatherproofing system that comply with the following limits for VOC content when calculated according to 40 CFR 59, Part 59, Subpart D (EPA Method 24):
 - 1. Architectural Sealants: 250 g/L.
 - 2. Sealant Primers for Nonporous Substrates: 250 g/L.
 - 3. Sealant Primers for Porous Substrates: 775 g/L.
- C. Colors of Exposed Joint Sealants: As selected by Architect from manufacturer's full standard range.

2.3 SILICONE JOINT SEALANTS

- A. Mildew-Resistant, Single-Component, Acid-Curing Silicone Joint Sealant: ASTM C 920, Type S, Grade NS, Class 25, for Use NT.
 - 1. Products: Subject to compliance with requirements, provide one of the following:
 - a. Dow Corning Corporation; 786 Mildew Resistant.
 - b. GE Advanced Materials - Silicones; Sanitary SCS1700.
 - c. Tremco Incorporated; Tremsil 200 Sanitary.
- B. Single-Component, Neutral-Curing Silicone Joint Sealant: ASTM C 920, Type S, Grade NS, Class 50, for Use NT, M, G, A and O.
 - 1. Products: Subject to compliance with requirements, provide one of the following:
 - a. Dow Corning Corporation; 790.
 - b. GE Advanced Materials: SilPruf SCS 2700 LM
 - c. Tremco Incorporated; Spectrem 3
- C. Single-Component, Neutral-Curing Silicone Joint Sealant: ASTM C 920, Type S, Grade NS, Class 50, for Use NT, G, A and O.
 - 1. Products: Subject to compliance with requirements, provide one of the following:
 - a. Dowsil 795 Silicone structural Sealant.
 - b. GE Advanced Materials: SilPruf SCS - 2000
 - c. Tremco Incorporated; Spectrem 2
 - d. Pecora 864 Silicone

2.4 URETHANE JOINT SEALANTS

- A. Single-Component, Nonsag, Urethane Joint Sealant: ASTM C 920, Type S, Grade NS, Class 25, for Use NT.

1. Products: Subject to compliance with requirements, provide one of the following:
 - a. Pecora Corporation; Dynatrol I-XL.
 - b. Sika Corporation, Construction Products Division; Sikaflex - 1a.
 - c. Tremco Incorporated; Dymonic 100

2.5 ACOUSTICAL JOINT SEALANTS

- A. Acoustical Joint Sealant: Manufacturer's standard nonsag, paintable, nonstaining latex sealant complying with ASTM C 834. Product effectively reduces airborne sound transmission through perimeter joints and openings in building construction as demonstrated by testing representative assemblies according to ASTM E 90.
 1. Products: Subject to compliance with requirements, provide one of the following:
 - a. Pecora Corporation; AC-20 FTR.
 - b. USG Corporation; SHEETROCK Acoustical Sealant.

2.6 JOINT SEALANT BACKING

- A. General: Provide sealant backings of material that are nonstaining; are compatible with joint substrates, sealants, primers, and other joint fillers; and are approved for applications indicated by sealant manufacturer based on field experience and laboratory testing.
- B. Cylindrical Sealant Backings Rods: ASTM C 1330, Type C, Closed Cell, provide backing rods of size and density to control sealant depth and otherwise contribute to producing optimum sealant performance.
- C. Bond-Breaker Tape: Polyethylene tape or other plastic tape recommended by sealant manufacturer for preventing sealant from adhering to rigid, inflexible joint-filler materials or joint surfaces at back of joint. Provide self-adhesive tape where applicable.

2.7 MISCELLANEOUS MATERIALS

- A. Primer: Material recommended by joint-sealant manufacturer where required for adhesion of sealant to joint substrates indicated, as determined from preconstruction joint-sealant-substrate tests and field tests.
- B. Cleaners for Nonporous Surfaces: Chemical cleaners acceptable to manufacturers of sealants and sealant backing materials, free of oily residues or other substances capable of staining or harming joint substrates and adjacent nonporous surfaces in any way, and formulated to promote optimum adhesion of sealants to joint substrates.
- C. Masking Tape: Nonstaining, nonabsorbent material compatible with joint sealants and surfaces adjacent to joints.

PART 3 - EXECUTION

3.1 EXAMINATION

- A. Examine joints indicated to receive joint sealants, with Installer present, for compliance with requirements for joint configuration, installation tolerances, and other conditions affecting joint-sealant performance.

3.2 PREPARATION

- A. Surface Cleaning of Joints: Clean out joints immediately before installing joint sealants to comply with joint-sealant manufacturer's written instructions and the following requirements:
 - 1. Remove all foreign material from joint substrates that could interfere with adhesion of joint sealant, including dust, paints (except for permanent, protective coatings tested and approved for sealant adhesion and compatibility by sealant manufacturer), old joint sealants, oil, grease, waterproofing, water repellents, water, surface dirt, and frost.
 - 2. Clean porous joint substrate surfaces by brushing, grinding, mechanical abrading, or a combination of these methods to produce a clean, sound substrate capable of developing optimum bond with joint sealants. Remove loose particles remaining after cleaning operations above by vacuuming or blowing out joints with oil-free compressed air.
 - 3. Remove laitance and form-release agents from concrete.
 - 4. Clean nonporous joint substrate surfaces with chemical cleaners or other means that do not stain, harm substrates, or leave residues capable of interfering with adhesion of joint sealants.
- B. Joint Priming: Prime joint substrates where recommended by joint-sealant manufacturer. Apply primer to comply with joint-sealant manufacturer's written instructions. Confine primers to areas of joint-sealant bond; do not allow spillage or migration onto adjoining surfaces.
- C. Masking Tape: Use masking tape where required to prevent contact of sealant or primer with adjoining surfaces that otherwise would be permanently stained or damaged by such contact or by cleaning methods required to remove sealant smears. Remove tape immediately after tooling without disturbing joint seal.

3.3 INSTALLATION OF JOINT SEALANTS

- A. General: Comply with joint-sealant manufacturer's written installation instructions for products and applications indicated, unless more stringent requirements apply.
- B. Sealant Installation Standard: Comply with recommendations in ASTM C 1193 for use of joint sealants as applicable to materials, applications, and conditions indicated.
- C. Install sealant backings of kind indicated to support sealants during application and at position required to produce cross-sectional shapes and depths of installed sealants relative to joint widths that allow optimum sealant movement capability.
 - 1. Do not leave gaps between ends of sealant backings.
 - 2. Do not stretch, twist, puncture, or tear sealant backings.
 - 3. Remove absorbent sealant backings that have become wet before sealant application and replace them with dry materials.
- D. Install bond-breaker tape behind sealants where sealant backings are not used between sealants and backs of joints.
- E. Install sealants using proven techniques that comply with the following and at the same time backings are installed:
 - 1. Place sealants so they directly contact and fully wet joint substrates.
 - 2. Completely fill recesses in each joint configuration.
 - 3. Produce uniform, cross-sectional shapes and depths relative to joint widths that allow optimum sealant movement capability.

- F. Tooling of Nonsag Sealants: Immediately after sealant application and before skinning or curing begins, tool sealants according to requirements specified in subparagraphs below to form smooth, uniform beads of configuration indicated; to eliminate air pockets; and to ensure contact and adhesion of sealant with sides of joint.
 - 1. Remove excess sealant from surfaces adjacent to joints.
 - 2. Use tooling agents that are approved in writing by sealant manufacturer and that do not discolor sealants or adjacent surfaces.
 - 3. Provide concave joint profile per Figure 8A in ASTM C 1193, unless otherwise indicated.
 - a. Use masking tape to protect surfaces adjacent to recessed tooled joints.

- G. Acoustical Sealant Installation: At sound-rated assemblies and elsewhere as indicated, seal construction at perimeters, behind control joints, and at openings and penetrations with a continuous bead of acoustical sealant. Install acoustical sealant at both faces of partitions at perimeters and through penetrations. Comply with ASTM C 919 and with manufacturer's written recommendations.

3.4 CLEANING

- A. Clean off excess sealant or sealant smears adjacent to joints as the Work progresses by methods and with cleaning materials approved in writing by manufacturers of joint sealants and of products in which joints occur.
- B. Clean under provisions of Section 01 70 00.

3.5 PROTECTION

- A. Protect joint sealants during and after curing period from contact with contaminating substances and from damage resulting from construction operations or other causes so sealants are without deterioration or damage at time of Substantial Completion. If, despite such protection, damage or deterioration occurs, cut out and remove damaged or deteriorated joint sealants immediately so installations with repaired areas are indistinguishable from original work.

3.6 JOINT-SEALANT SCHEDULE

- A. Joint-Sealant Application: Interior joints in vertical surfaces and horizontal nontraffic surfaces.
 - 1. Joint Locations:
 - a. Control and expansion joints on exposed interior surfaces of exterior walls.
 - b. Perimeter joints of exterior openings where indicated.
 - c. Tile control and expansion joints.
 - d. Vertical joints on exposed surfaces of interior unit masonry, concrete walls and partitions.
 - e. Perimeter joints between interior wall surfaces and frames of interior doors and windows.
 - f. Openings around all penetrations through partitions and perimeter of partitions designated as smoke partitions.
 - g. Other joints as indicated.
 - 2. Urethane Joint Sealant: Single component, nonsag, Class 35
 - 3. Joint-Sealant Color: As selected by Architect from manufacturer's full standard range.

- B. Joint-Sealant Application: Mildew-resistant interior joints in vertical surfaces and horizontal nontraffic surfaces.
 - 1. Joint Sealant Location:
 - a. Joints between plumbing fixtures and adjoining walls, floors, and counters.
 - b. Tile control and expansion joints where indicated.
 - c. Other joints as indicated.
 - 2. Joint Sealant: Mildew resistant, single component, nonsag, mildew resistant, acid curing.
 - 3. Joint-Sealant Color: As selected by Architect from manufacturer's full standard range.

- C. Joint-Sealant Application: Exterior joints in vertical surfaces and horizontal nontraffic surfaces.
 - 1. Joint Locations:
 - a. Construction joints in cast-in-place concrete.
 - b. Control and expansion joints in unit masonry.
 - c. Joints in dimension stone cladding.
 - d. Joints in exterior insulation and finish systems.
 - e. Joints between metal panels.
 - f. Joints between different materials listed above.
 - g. Perimeter joints between materials listed above and frames of doors, windows and louvers.
 - h. Control and expansion joints.
 - i. Other joints as indicated.
 - 2. Silicone Joint Sealant: Single component, Type S, Grade NS, Class 50.
 - 3. Joint-Sealant Color: As selected by Architect from manufacturer's full standard range.

- D. Joint-Sealant Application: Interior acoustical joints in vertical surfaces and horizontal nontraffic surfaces.
 - 1. Joint Location:
 - a. Acoustical joints where indicated.
 - b. Other joints as indicated.
 - 2. Joint Sealant: Acoustical
 - 3. Joint-Sealant Color: As selected by Architect from manufacturer's full standard range.

END OF SECTION

THIS PAGE INTENTIONALLY LEFT BLANK

SECTION 08 12 13

STEEL DOOR FRAMES

PART 1 - GENERAL

1.01 SUMMARY

- A. Related Documents:
The Drawings and general provisions of the Contract, including General and Supplementary General Conditions, and Division 1 Requirements, apply to the work in this Section.

1.02 WORK INCLUDED

- A. Steel door frames.

1.03 RELATED WORK

- A. Section 08 13 13 - Steel Doors
- B. Section 08 14 16 - Wood Doors
- C. Section 08 71 00 – Door Hardware
- D. Section 08 81 00 - Glass and Glazing
- E. Section 09 91 00 - Painting: Field painting of frames.
- F. Division 4 - Masonry: Mortar fill of metal frames.

1.04 REFERENCES

- A. DHI - Door Hardware Institute: The Installation of Commercial Steel Doors and Steel Frames, Insulated Steel Doors in Wood Frames and Builder's Hardware.
- B. ANSI/SDI-100 - Standard Steel Doors and Frames
- C. ANSI/SDI A250.11 - Recommended Erection Instructions for Steel Frames.
- D. ASTM - E152 - Methods of fire tests of door assemblies.
- E. NFPA 252 - Fire tests of door assemblies.
- F. UL 10B - Fire Tests of door assemblies.

1.05 QUALITY ASSURANCE

- A. Conform to requirements of the DHI, SDI-100, and ANSI/SDI-A250.11.
- B. Fire rated door frames are to also conform to the requirements of NFPA 252 ASTM E152 and UL10B.

1.06 REGULATORY REQUIREMENTS

- A. Conform to State Building Code and State Fire Code for fire rated frames.

1.07 SUBMITTALS

- A. Submit shop drawings and product data under provisions of Section 01 33 00.
- B. Indicate frame configuration, anchor types and spacings, location of cutouts for hardware, reinforcement, and finish.
- C. Submit manufacturer's installation instructions under provisions of Section 01 33 00.
- D. Sustainable Design Submittal:
 - 1. Provide documentation indicating percentages of post-consumer and pre-consumer recycled content.
 - 2. Identify each regional material along with the location of its harvest, extraction, or manufacture.

1.08 DELIVERY, STORAGE AND PROTECTION

- A. Protect products under provisions of Section 01 60 00.
- B. Protect frames with resilient packaging sealed with heat shrunk plastic.
- C. Break seal on-site to permit ventilation.

PART 2 - PRODUCTS

2.01 MANUFACTURERS

- A. Subject to compliance with requirements of this Specification Section, provide products listed herein from one of the following:
 - 1. Ceco Door
 - 2. De La Fontaine
 - 3. Steelcraft
- B. Basis of Design: Steelcraft
- C. Substitutions: Under provisions of Section 01 60 00.

2.02 METAL FRAMES

- A. TYPES
 - 1. Exterior frames: Steelcraft Model F14-4 (14 gage galvanized steel with 2" face for 1-3/4" doors)
 - 2. Interior frames: Steelcraft Model F16-4 (16 gage cold rolled steel with 2" face for 1-3/4" doors.)

B. FABRICATION

1. All frames in new partitions shall be furnished as a welded unit with mitered corners. Miter and entire connection is to be continuous fully welded. Welds are ground and finished smooth.
2. Knocked-down field assembly frames may only be used at existing drywall and interior masonry partitions.
3. Fabricate frames with hardware reinforcement plates welded in place as required to coordinate with hardware schedule. Provide mortar guard boxes, 22 gage.
4. Reinforce frames wider than 48 inches with roll formed steel channels fitted tightly into frame head, flush with top.
5. Prepare frame for silencers. Provide three single rubber silencers for single doors on strike side, and two single silencers on frame head at double doors without mullions.
6. Fabricate frames for masonry wall coursing with a 4 inch head member (unless indicated otherwise).
7. Frames shall be furnished with a minimum of six wall anchors and two base anchors of manufacturer's standard design. Jamb anchors shall be as required to coordinate with the adjacent wall construction.
8. All fire rated frames shall carry a UL label.
9. Provide a temporary spreader bar securely fastened to the bottom of each frame.
10. The inside profile of all frames to be filled with mortar shall be coated with bituminous coating to a thickness of 1/16 inch. Coating may be field applied.
11. Cold-rolled steel frame material is to contain a minimum of 20 % Pre-Consumer recycled content and 45% Post-Consumer recycled content.
Galvanized steel frame material is to contain a minimum of 5 % Pre-Consumer recycled content and 20% Post-Consumer recycled content.
12. Anchors
 - a. Quantity: Minimum 3 anchors per jamb.
 - b. Jambs over 8'-0" in height: 1 additional anchor for each 2'-0" or fraction thereof.
 - c. Construction: 18-gage steel strap or 3/16" diameter wire, adjustable or "T" shaped.
 - d. Floor anchors: Welded inside each jamb. Up to 2 inch adjustable permitted subject to compliance with standards.

2.03 GLAZED VISION PANELS

- A. Provide glazed vision panels in metal frames as shown on the drawings.
- B. Glazing shall be of the type specified in Section 08 81 00.
- C. Provide fixed stop on one side of glazing and a removable stop of 20 gauge steel on the other. Attach stop to frame with machine screws uniformly spaced at 12" maximum o.c.

2.04 FINISH

- A. After fabrication, all tool marks and surface imperfections shall be dressed, filled and sanded as required to make all faces and vertical edges smooth, level and free of all irregularities.
- B. Frames shall be thoroughly cleaned and phosphatized.

- C. All surfaces exposed to view shall receive a factory applied single coat of rust inhibiting prime paint baked-on in accordance with ANSI A224,1.
- D. The finish coats of paint shall be field applied by others in accordance with the painting section of these specifications.
- E. Where wall anchors utilizing exposed screw heads are used to install door frames, the exposed screws are to be covered with epoxy resin filler (Bondo or equal) and sanded smooth to match flush with the surrounding face.

PART 3 - EXECUTION

3.01 INSTALLATION OF FRAMES

- A. Install frames in accordance with ANSI/SDI A250.11.
- B. Install the frames plumb, rigid, and in true alignment and fasten them so as to retain their position.
- C. All frames in new masonry walls shall be filled with mortar as they are laid-up. Also, the CMU hollow core nearest the new door frame is to be filled solid with grout full height of masonry opening. Coordinate with door frame's wall anchors.
- D. Coordinate with masonry wall construction for anchor placement.

3.02 CLEANING

- A. Clean in accordance with Section 01 70 00.

END OF SECTION

SECTION 08 13 13

STEEL DOORS

PART 1 - GENERAL

1.01 WORK INCLUDED

- A. Steel doors.

1.02 RELATED WORK

- A. Section 08 12 13 - Steel Door Frames
- B. Section 08 71 00 – Door Hardware
- C. Section 08 71 50 – Weatherstripping
- D. Section 08 81 00 – Glass and Glazing
- E. Section 08 88 13 - Fire Rated Glass
- F. Section 09 91 00 - Painting: Field painting of doors and frames.

1.03 REFERENCES

- A. DHI - Door Hardware Institute: The Installation of commercial steel doors and steel frames, insulated steel doors in wood frames and builder's hardware.
- B. ANSI/SDI-100 - Standard Steel Doors and Frames
- C. ASTM E152 - Methods of Fire Tests of Door Assemblies
- D. UL 10B - fire Tests of Door Assemblies
- E. NFPA - 80 - Fire Doors and Windows
- F. NFPA - 252 - Fire Tests for Door Assemblies

1.04 QUALITY ASSURANCE

- A. Conform to requirements of SDI-100.
- B. Fire rated door and frame construction to conform to ASTM E152, NFPA 80, NFPA 252, and UL 10B.

1.05 REGULATORY REQUIREMENTS

- A. Conform to State Building Code and State Fire Code for fire rated frames and doors.

1.06 SUBMITTALS

- A. Submit shop drawings and product data under provisions of Section 01 31 00.
- B. Indicate door elevations, internal reinforcement, closure method, and cut outs for glazing.
- C. Submit manufacturer's installation instructions under provisions of Section 01 33 00.
- D. Sustainable Design Submittal:
 - 1. Provide documentation indicating percentages of post-consumer and pre-consumer recycled content.
 - 2. Identify each regional material along with the location of its harvest, extraction, or manufacture.

1.07 DELIVERY, STORAGE AND PROTECTION

- A. Protect products under provisions of Section 01 60 00.
- B. Protect doors with resilient packaging sealed with heat shrunk plastic.
- C. Break seal on-site to permit ventilation.

PART 2 - PRODUCTS

2.01 MANUFACTURERS

- A. Steelcraft
- B. Other acceptable manufacturers offering equivalent products.
 - 1. Ceco Door
 - 2. De La Fontaine
- C. Substitutions: Under provisions of Section 01 60 00.

2.02 HOLLOW METAL DOORS

- A. TYPES
 - 1. Interior doors: Rated and non-rated SDI Grade II, heavy duty, Model 2 (seamless and 18 gage) (Steelcraft LW door series)
Rated doors shall be as follows:
 - 1-1/2 hr. rating
 - 3/4 hr. rating
 - 2. Exterior doors: SDI Grade III, extra heavy duty, Model 2 (seamless and 16 gage) (Steelcraft LW door series)

B. MATERIALS

1. Interior fire rated doors:
 - a. Faces: 18 gage, cold rolled steel conforming to ASTM A-366-68
 - b. Perimeter channels to be 16 gage and welded to panels
 - c. Core to be honeycomb.
 - d. All fire rated doors shall carry a UL label.
2. Interior non-rated doors:
 - a. Faces: 18 gage, cold rolled steel conforming to ASTM A-366-68
 - b. Perimeter channels to be 16 gage and welded to panels
 - c. Core to be honeycomb.
3. Exterior doors:
 - a. Faces: 16 gage, A60 galvanized steel in accordance with ASTM A525. (A60 coating is .6 oz. of zinc per square foot of steel total coverage)
 - b. Channels to be 16 gage and perimeter welded to panels.
 - c. Core shall be foamed-in-place polyurethane insulation, "R" factor 11.1, compression strength 3600 PSI.
 - d. Top cap required.

C. FABRICATION

1. All doors shall be custom made, of the types and sizes shown on approved shop drawings, and shall be fully welded seamless construction with no visible seams or joints on their faces or vertical edges. Inverted end channel on bottom welded to both face sheets. Door thickness shall be 1-3/4" unless noted otherwise.
2. All doors shall be strong, rigid and neat in appearance, free from warpage or buckle. Corner bends shall be true and straight and of minimum radius for the gage of metal used.
3. Door faces shall be joined at their vertical edges by a continuous weld extending the full height of the door seam. All such welds shall be ground and smoothed to make them invisible and provide a smooth flush surface.
4. The vertical edge profiles on single acting swing doors shall be beveled 1/8" in 2".
5. All hardware furnished by the hardware contractor for single-acting doors shall be designed for beveled edges as specified above.
6. Hardware reinforcements:
 - a. Doors shall be mortised, reinforced, drilled and tapped at the factory for fully templated hardware in accordance with the approved hardware schedule and templates provided by the hardware contractor. Where surface-mounted hardware (or hardware, the interrelation of which is to be adjusted upon installation-such as top and bottom pivots, floor closers, etc.) is to be applied, doors shall have reinforcing plates only: all drilling and tapping shall be done by the installer.

- b. Minimum gages for hardware reinforcing plates shall be as follows:
 - 1. Hinge and pivot reinforcements 7 gage.
 - 2. Concealed or surface mounted closers - 14 gage.
 - 3. Lock face, flush bolts and all other surface mounted hardware - 16 gage.
- 7. Cold-rolled steel door material is to contain a minimum of 20 % Pre-Consumer recycled content and 45% Post-Consumer recycled content.
Galvanized steel door material is to contain a minimum of 5 % Pre-Consumer recycled content and 20% Post-Consumer recycled content.

D. ACCESSORIES

- 1. Glass mouldings and stops:
 - a. Where specified or scheduled, doors shall be provided with hollow metal mouldings to secure glazing by others in accordance with glass opening sizes and glass type shown on approved shop drawings.
 - b. Fixed mouldings shall be securely welded to the door on the security side.
 - c. Loose stops shall be not less than 20 gage steel, with mitered corner joints, secured to the framed opening by cadium or zinc-coated countersunk screws. Snap-on attachments will not be permitted.

2.04 FINISH

- A. After fabrication, all tool marks and surface imperfections shall be dressed, filled and sanded as required to make all faces and vertical edges smooth, level and free of all irregularities.
- B. Doors shall be thoroughly cleaned and phosphatized.
- C. All surfaces exposed to view shall receive a factory applied single coat of rust inhibiting prime paint baked-on in accordance with ANSI A224,1.
- D. The finish coats of paint shall be field applied by others in accordance with the painting section of these specifications.

PART 3 - EXECUTION

3.01 INSTALLATION OF DOORS

- A. Install doors in accordance with DHI.
- B. Install doors plumb and in true alignment in a prepared opening and fasten them to achieve the maximum operational effectiveness and appearance.

3.02 TOLERANCES

- A. Maximum Diagonal Distortion: 1/16 inch measured with straight edge, corner to corner.

- B. Clearances:
Provide 1/8 inch at heads, jambs, and between pairs of doors.
Provide 3/4 inch maximum from bottom of door to top of decorative floor finish or covering unless otherwise indicated.

- C. Install fire-rated doors according to NFPA 80. Install smoke- and draft-control doors according to NFPA 105. All doors that are smoke doors or fire rated and are being installed in new frames are to be sized as required to meet the code requirement clearances around the perimeter between the door, meeting edges of door pairs, finish floor and the frame.

3.03 ADJUSTING AND CLEANING

- A. Adjust hardware for smooth and balanced door movement.

- B. Clean in accordance with Section 01 70 00.

END OF SECTION

THIS PAGE INTENTIONALLY LEFT BLANK

SECTION 08 14 16

WOOD DOORS

PART 1 - GENERAL

1.1 SUMMARY

- A. Related Documents:
The Drawings and general provisions of the Contract, including General and Supplementary General Conditions, and Division 1 Requirements, apply to the work in this Section.

1.2 SECTION INCLUDES

- A. Wood doors; flush configuration; fire-rated and non-rated.

1.3 RELATED SECTIONS

- A. Section 08 12 13 - Steel Door Frames
- B. Section 08 71 00 – Door Hardware
- C. Section 08 81 00 – Glass and Glazing
- D. Section 08 88 13 - Fire Rated Glass
- E. Section 09 91 00 - Painting: Metal components (i.e. light frames, astragals, etc.)

1.4 REFERENCES

- A. ASTM E90 - Measurement of Airborne Sound Transmission Loss of Building Partitions.
- B. ASTM E413 - Classification for Determination of Sound Transmission Class.
- C. AWI - Architectural Woodwork Institute Quality Standards.
- D. ASTM E152 - Methods of Fire Tests of Door Assemblies.
- E. NFPA 80 - National Fire Protection Association Pamphlet 80 Fire Doors and Windows.
- F. NFPA 252 - National Fire Protection Association Standard Method of Fire Tests for Door Assemblies.
- G. L 10B - Underwriters Laboratories Fire Tests of Door Assemblies.

1.5 SUBMITTALS

- A. Submit under provisions of Section 01 33 00.
- B. Shop Drawings: Illustrate door location (Room # to Room #), door opening criteria, elevations, sizes, types, swings, undercuts required, special beveling, special blocking for hardware, identify cutouts for glazing.

- C. Product Data: Indicate door core materials and construction; veneer species, type and characteristics; factory machining criteria, factory finishing criteria.
- D. Samples: Submit two 12"X12" corner samples of door construction. (As required by architect)
- E. Manufacturer's Instructions: Submit instructions regarding care of door during shipping, unloading, storage, preparation for hanging and hanging.

1.6 REGULATORY REQUIREMENTS

- A. Fire-Rated Door Construction: Conform to ASTM E152 NFPA 252 UL 10B WHI.
- B. Installed Door Assembly: Conform to NFPA 80 for fire-rated class as scheduled. as indicated on Drawings.
- C. All door assemblies shall meet the requirements of the State Building and State Fire Codes.

1.7 QUALITY ASSURANCE

- A. Product Performance: Provide documents showing compliance to the following WDMA attributes, validating the specified WDMA Performance Duty Level:
 - 1. Adhesive Bonding Durability: WDMA TM-6
 - 2. Cycle Slam: WDMA TM-7
 - 3. Hinge Loading: WDMA TM-8
 - 4. Screw Holding: WDMA TM-10

1.8 DELIVERY, STORAGE AND HANDLING

- A. Deliver, store, protect and handle products to job site under provisions of Section 01 60 00 and manufacturer's instructions.
- B. Accept doors at job site in manufacturer's standard packaging. Inspect for damage.
- C. Do not store in damp or wet areas. Cover stored doors with opaque covering material where sunlight might bleach veneer. Seal top and bottom edges if stored more than one week.
- D. Break seal at job site to permit ventilation.
- E. Mark each door on top rail with opening number used on Shop Drawings. Include manufacturer's order number and date of manufacture.
- F. Environmental Limitations: Do not deliver or install doors until spaces are enclosed and weather tight, wet work in spaces is complete and dry, and HVAC system is operating and maintaining temperature between 60 and 90 deg F and relative humidity between 25 and 55 percent during remainder of construction period.

1.9 FIELD MEASUREMENTS

- A. Verify all dimensions at the site prior to fabrication. Any inconsistencies shall be communicated to the architect for clarification.

1.10 COORDINATION

- A. Coordinate work under provisions of Section 01 30 00.
- B. Coordinate the work with door opening construction, door frame, hardware and weatherstripping installation.

1.11 WARRANTY

- A. Provide manufacturer's warranty including replacement, refinishing, and rehangng, under provisions of Section 01 78 00 for the "Life of Original Installation" (unlimited lifetime).
- B. Include coverage for delamination of veneer, warping beyond specified installation tolerances, defective materials, telegraphing core construction.

PART 2 - PRODUCTS

2.1 MANUFACTURER

- A. Subject to compliance with requirements of this Specification Section, provide products listed herein from one of the following:
 - 1. Eggers Industries
 - 2. Lambton Doors
 - 3. Masonite Architectural
- B. Basis of Design: Masonite Architectural
- C. Substitutions: Under provisions of Section 01 60 00.
- D. Supply all wood doors from same manufacturer.

2.2 DOOR DESCRIPTION

- A. Flush interior doors (non-rated): Aspiro™ Series, Model A-PC-B-NR
 - 1. Provide wood-based particleboard core doors with a minimum density per ANSI A208.1, Grade LD-2 as required to meet WDMA Performance Duty level specified without added blocking.
- B. Flush interior single doors (fire rated): Model A-MC-B-FR45 (3/4 hour rated), A-MC-B-FR60 (1 hour rated), A-MC-B-FR90 (1 ½ hour rated) solid mineral core construction.
- C. Flush interior paired fire rated doors: PairGuard intumescent stiles with either a DFM-45 (3/4 hour rated), DFM-60 (1 hour rated), or DFM-90 (1 ½ hour rated) solid mineral core construction.

2.3 TYPICAL COMPONENTS

- A. Veneer
 - 1. Grade 1 (WDMA Quality grade: Premium)

2. Veneer is to be of sufficient thickness so as not to permit show-through of crossbanding after sanding or finishing.
3. Species: Select white birch
4. Cut: Rotary cut
5. Match between Veneer Leaves: balanced Book match grain.
6. Core: Wood-based Particleboard (PC) for non-rated and solid mineral core construction for fire rated.
7. Construction: Five plies. Stiles and rails are bonded to core, and then entire unit is abrasive planed before veneering.
8. Vertical Edges: Matching/compatible hardwood, finished to match the face.
9. WDMA I.S.1-A Performance Grade: Heavy Duty.

B. Thickness

1. 1-3/4 inch thick unless indicated otherwise on the drawings

C. Stiles and rails shall be hardwood

2.4 ACCESSORIES

A. Vision frames:

1. Non-rated: Model W-6 wood of same species as door veneer with mitered corners. (Installed by door manufacturer)
2. Rated: Metal frame as required to conform to door label. Factory primed for field applied paint. (Supplied loose by the door manufacturer)

B. Glass:

1. Non-rated safety glass shall be provided and installed by the door manufacturer. Glass shall be as specified in Section 08 81 00.
2. Fire rated safety glass shall be provided and shipped loose by the door manufacturer. Glass shall be as specified in Section 08 88 13.

2.5 FABRICATION

- A. Fabricate doors in accordance with specified manufacturers and WHI and UL requirements.
- B. Laminate door facing, cross banding, and assembled core in a hot press.
- C. Provide non-rated flush doors with stiles of wood species to match face veneer.
- D. Bond stiles and rails to cores. Sand the assembled core for uniform thickness.
- E. Factory sand assembled door leaf.
- F. Factory machine doors for finish hardware in accordance with hardware requirements and dimensions. Do not machine for surface hardware.
- G. Factory fit doors for frame opening dimensions identified on shop drawings.
- H. All fire rated doors shall be fabricated with fire retardant, solid wood inner blocking for positive attachment of all surface mounted hardware. Through-bolts will not be allowed.

2.6 FINISH

- A. Doors to be factory finished and sealed on all six sides with the following: Transparent, WDMA TR-8, UV-Cured Acrylated Polyester/Urethane.
Stained in color and sheen as selected by the Architect from the manufacturer's standard choices, submit samples of colors on wood species selected.
- B. All metal accessories shall receive a prime coat of factory applied baked-on prime coat of paint.

PART 3 - EXECUTION

3.1 EXAMINATION

- A. Verify that opening sizes and tolerances are acceptable.
- B. Do not install doors in frame openings that are not plumb or are out of tolerance for size or alignment.

3.2 INSTALLATION

- A. Installation Instructions: Install doors to comply with manufacturer's written instructions, referenced quality standard, and as indicated.
- B. Trim non-rated door width by cutting equally on both jamb edges.
- C. Any cut doors are to have the cut surfaces finished (sealed) to match the remainder of the door.
- D. Pilot drill screw and bolt holes using templates provided.
- E. Coordinate installation of doors with installation of frames and hardware specified.
- F. Install fire-rated doors according to NFPA 80.
- G. Align and fit doors in frames with uniform clearances and bevels as indicated below; do not trim stiles and rails in excess of limits set by manufacturer or permitted for fire-rated doors. Machine doors for hardware. Seal edges of doors, edges of cutouts, and mortises after fitting and machining.
 - 1. Clearances:
Provide 1/8 inch at heads, jambs, and between pairs of doors.
Provide 3/4 inch maximum from bottom of door to top of decorative floor finish or covering unless otherwise indicated.
 - 2. Bevel non-fire-rated doors 1/8 inch in 2 inches (3-1/2 degrees) at lock and hinge edges.
 - 3. Trim bottom rail only to extent permitted by labeling agency.

3.3 INSTALLATION TOLERANCES

- A. Maximum Diagonal Distortion (Warp): 1/4 inch measured with straight edge or taut string, corner to corner, over a maximum 42 x 84 inch surface area.
- B. Maximum Vertical Distortion (Bow): 1/4 inch measured with straight edge or taut string, top to bottom, over a maximum 42 x 84 inch surface area.
- C. Maximum Width Distortion (Cup): 1/4 inch measured with straight edge or taut string, edge to edge, over a maximum 42 x 84 inch surface area.

3.4 ADJUSTING

- A. Adjust door for smooth and balanced door movement.
- B. Operation: Correct any deficiency that prohibits the door from swinging or operating freely. Do not remove hinge screws after initial insertion. Shims used for alignment purposes must be inserted between hinge and frame. Do not insert shims between hinge and door.
- C. To prevent stile failure, insure that door closers are properly adjusted and do not limit the door opening swing. Limit door opening swing only with a properly located stop.
- D. Finished Doors: Replace doors that are damaged or that do not comply with requirements. Doors may be repaired or refinished if Work complies with requirements and shows no evidence of repair or refinishing.

END OF SECTION

SECTION 08 14 19

WOOD BARN DOORS

PART 1 - GENERAL

1.1 SUMMARY

- A. Related Documents:
The Drawings and general provisions of the Contract, including General and Supplementary General Conditions, and Division 1 Requirements, apply to the work in this Section.

1.2 SECTION INCLUDES

- A. Wood barn doors; non-rated.

1.3 RELATED SECTIONS

- A. Section 09 91 00 - Painting

1.4 SUBMITTALS

- A. Submit under provisions of Section 01 33 00.
- B. Shop Drawings: Illustrate door location, door opening criteria, elevations, sizes, types, special blocking for hardware.
- C. Product Data: Indicate door materials and construction; species, type and characteristics; factory machining criteria, factory finishing criteria.
- D. Samples: Submit two 12"X12" corner samples of door construction. (As required by architect)
- E. Manufacturer's Instructions: Submit instructions regarding care of door during shipping, unloading, storage, preparation for hanging and hanging.

1.5 REGULATORY REQUIREMENTS

- A. All door assemblies shall meet the requirements of the State Building and State Fire Codes.

1.6 DELIVERY, STORAGE AND HANDLING

- A. Deliver, store, protect and handle products to job site under provisions of Section 01 60 00 and manufacturer's instructions.
- B. Accept doors at job site in manufacturer's standard packaging. Inspect for damage.
- C. Do not store in damp or wet areas. Cover stored doors with opaque covering material where sunlight might bleach veneer. Seal top and bottom edges if stored more than one week.
- D. Break seal at job site to permit ventilation.

- E. Mark each door on top rail with opening number used on Shop Drawings. Include manufacturer's order number and date of manufacture.

1.7 FIELD MEASUREMENTS

- A. Verify all dimensions at the site prior to fabrication. Any inconsistencies shall be communicated to the architect for clarification.

1.8 COORDINATION

- A. Coordinate work under provisions of Section 01 30 00.
- B. Coordinate the work with door opening construction, door frame, and hardware installation.

1.9 WARRANTY

- A. Provide manufacturer's warranty including replacement, refinishing, and rehung, under provisions of Section 01 78 00.

PART 2 - PRODUCTS

2.1 MANUFACTURER

- A. Basis of Design: Rustica
- B. Substitutions: Under provisions of Section 01 60 00.

2.2 DOOR DESCRIPTION

- A. Rustica Dutch Z exterior double slab door

2.3 COMPONENTS

- A. Exterior wood barn door
(To be used on the exterior of the animal shelters 1 through 5)
(NOTE: Also to be used for the stationary barn doors on the Pavillion.)
- B. Wood Species: Poplar
- C. Thickness: 2-1/4 inch
- D. Finish Ready and painted in field.
- E. No texture surface.
- F. No door bevel
- G. Provide all hardware as required for a complete installation.
 - Manufacturer: Rustica Stag design
 - Bi-parting stainless steel track system with a flat black finish
 - Total track length is to be verified with the Architect.
 - Two stainless steel wheels and face-of-door hangers per door leaf.
 - Adjustable end stops.

- Stainless steel guides (Stay Roller) at bottom of doors as required to hold doors against the wall. (So animals cannot push the door at the bottom to get out.)
- Latches fastening each door together to adjacent door. When closed, both doors are to be latched together.
- Any additional hardware to attach doors to the track and track to the wall.
- Provide Rustica Falcon style door pull on both sides of each door.
- Provide black iron barn door swing style latch hook as manufactured by Rural365 or equal. Latch is to be installed on the interior of the barn doors only.

PART 3 - EXECUTION

3.1 EXAMINATION

- A. Verify that opening sizes and tolerances are acceptable.

3.2 INSTALLATION

- A. Installation Instructions: Install doors to comply with manufacturer's written instructions, referenced quality standard, and as indicated.
- B. Coordinate installation of doors with installation of hardware specified.

3.3 ADJUSTING

- A. Adjust door for smooth and balanced door movement.
- B. Operation: Correct any deficiency that prohibits the door from operating freely.
- C. Finished Doors: Replace doors that are damaged or that do not comply with requirements. Doors may be repaired or refinished if Work complies with requirements and shows no evidence of repair or refinishing.

END OF SECTION

THIS PAGE INTENTIONALLY LEFT BLANK

SECTION 08 14 21

METAL SLIDING SHIFT DOORS

PART 1 - GENERAL

1.1 SUMMARY

- A. Related Documents:
The Drawings and general provisions of the Contract, including General and Supplementary General Conditions, and Division 1 Requirements, apply to the work in this Section.

1.2 SECTION INCLUDES

- A. Metal sliding shift doors, non-rated.

1.3 SUBMITTALS

- A. Submit under provisions of Section 01 33 00.
- B. Shop Drawings: Illustrate door location, door opening criteria, elevations, sizes, types, special blocking for hardware.
- C. Product Data: Indicate door materials and construction; type and characteristics; factory machining criteria, factory finishing criteria, hardware.
- D. Manufacturer's Instructions: Submit instructions regarding care of door during shipping, unloading, storage, preparation for hanging and hanging.

1.4 REGULATORY REQUIREMENTS

- A. All door assemblies shall meet the requirements of the State Building and State Fire Codes.

1.5 DELIVERY, STORAGE AND HANDLING

- A. Deliver, store, protect and handle products to job site under provisions of Section 01 60 00 and manufacturer's instructions.
- B. Accept doors at job site in manufacturer's standard packaging. Inspect for damage.
- C. Do not store in damp or wet areas. Cover stored doors. Seal top and bottom edges if stored more than one week.
- D. Break seal at job site to permit ventilation.
- E. Mark each door on top rail with opening number used on Shop Drawings. Include manufacturer's order number and date of manufacture.

1.6 FIELD MEASUREMENTS

- A. Verify all dimensions at the site prior to fabrication. Any inconsistencies shall be communicated to the architect for clarification.

1.7 COORDINATION

- A. Coordinate work under provisions of Section 01 30 00.
- B. Coordinate the work with door opening construction, door frame, and hardware installation.

1.8 WARRANTY

- A. Provide manufacturer's standard warranty including replacement, refinishing, and rehangng, under provisions of Section 01 78 00.

PART 2 - PRODUCTS

2.2 DOOR DESCRIPTION

- A. Galvanized steel, polyurethane insulated door with vision panel.
(Located between Shelters 1-5 and the Work Area C111)
- B. Galvanized steel, non-insulated door with no vision panel.
(Located between Shelter 1 &2 and Shelter 4 & 5)
- C. See Door Schedule on Drawings for additional information.

2.3 COMPONENTS

- A. Doors:
Thickness: 1-3/4 inch
Finish: Unpainted, to remain exposed galvanized finish.
- B. Provide all hardware as required for a complete installation.
- Manufacturer: Richards-Wilcox, Inc. (RW Hardware) or equal.
 - Hardware Kit to be # 1645.00004 includes the following:
 - Single sliding door, powder-coated steel box-type track system, sidewall mounted, 1,000 lb capacity.
 - Total track length is to be verified with the Architect.
 - Ball bearing hangers
 - Center, lock-joint and end brackets & blinds.
 - Bow handle on corridor side of door.
 - Flush pull on Shelter side of door.
 - Stay roller with guide roller strip on door.
 - End stops set into concrete floor.
 - Bumper shoes.
 - Hook latch to hold door in closed position.
 - Any additional hardware required to attach doors to the track and track to the wall.

PART 3 - EXECUTION

3.1 EXAMINATION

- A. Verify that opening sizes and tolerances are acceptable.

3.2 INSTALLATION

- A. Installation Instructions: Install doors to comply with manufacturer's written instructions, referenced quality standard, and as indicated.
- B. Coordinate installation of doors with installation of hardware specified.

3.3 ADJUSTING

- A. Adjust door for smooth and balanced door movement.
- B. Operation: Correct any deficiency that prohibits the door from operating freely.
- C. Finished Doors: Replace doors that are damaged or that do not comply with requirements. Doors may be repaired or refinished if Work complies with requirements and shows no evidence of repair or refinishing.

END OF SECTION

THIS PAGE INTENTIONALLY LEFT BLANK

SECTION 08 31 13

ACCESS DOORS

PART 1 - GENERAL

1.01 SUMMARY

- A. Related Documents:
The Drawings and general provisions of the Contract, including General and Supplementary General Conditions, and Division 1 Requirements, apply to the work in this Section.

1.02 WORK INCLUDED

- A. Fire resistive rated and non-rated access doors and frames.

1.03 RELATED WORK

- A. Section 09 21 16 - Steel Framed Drywall System
- B. Section 09 91 00 - Painting: Field paint finish.

1.04 QUALITY ASSURANCE

- A. Manufacture fire rated access doors and frames to conform to UL requirements and state and local codes.
- B. Provide labels indicating rating.

1.05 SUBMITTALS

- A. Submit product data under provisions of Section 01 33 00.
- B. Include sizes, types, finishes, scheduled locations, and details of adjoining work.
- C. Submit manufacturer's installation instructions under provisions of Section 01 33 00.

PART 2 - PRODUCTS

2.01 ACCEPTABLE MANUFACTURERS

- A. Subject to compliance with requirements of this Specification Section, provide products listed herein from one of the following:
 - 1. Larsen
 - 2. Milcor
 - 3. Nystrom
- B. Basis of Design: Milcor
- C. Substitutions: Under provisions of Section 01 60 00.

2.02 ACCESS DOORS

Wherever **wall** access panels are required per the Drawings or Project Manual, provide the following:

- Non-fire rated partitions: Milcor Model 3202XXX (or equal), minimum size 12"x12", gray prime painted steel. Provide masonry anchors as required for masonry walls. Screwdriver cam latch. Finish paint in the field.
- Fire rated partitions: Milcor Model 32180XX (or equal), fire rated model minimum size 12"x12", UL label fire rating of 90 minutes, gray prime painted steel. Provide masonry anchors as required for masonry walls. Screwdriver cam latch. Finish paint in the field.

2.03 FABRICATION

- A. Fabricate frames of 16 gage steel and door panels of 14 gage steel.
- B. Hardware:
 - 1. Concealed spring hinges.
 - 2. Flush, screwdriver operated with steel cam lock.

2.04 FINISH

- A. Provide factory painted, electro-statically applied white primer finish.
- B. Paint in field to match surrounding surface.

PART 3 - EXECUTION

3.01 INSPECTION

- A. Verify rough openings for door and frame are correctly sized and located.
- B. Beginning of installation means acceptance of existing conditions.

3.02 INSTALLATION

- A. Install frame plumb and level in opening.
- B. Position to provide convenient access to concealed work requiring access.
- C. Secure rigidly in place in accordance with manufacturer's instructions.

END OF SECTION

SECTION 08 33 44

ROLLING FIRE DOORS

PART 1 GENERAL

1.1 SECTION INCLUDES

- A. Rolling fire service doors.

1.2 RELATED SECTIONS

- A. Section 05 50 00-Miscellaneous Metal Work: Support framing and framed opening.
- B. Section 09 91 00 - Painting: Field applied finish.

1.3 REFERENCES

- A. ASTM A 653 - Standard Specification for Steel Sheet, Zinc-Coated (Galvanized) or Zinc-Iron Alloy-Coated (Galvannealed) by the Hot-Dip Process.
- B. ASTM A 666 - Standard Specification for Austenitic Stainless Steel Sheet, Strip, Plate, and Flat Bar.
- C. ASTM A 924 - Standard Specification for General Requirements for Steel Sheet, Metallic-Coated by the Hot-Dip Process.
- D. NFPA-80 – Standard for Fire Doors and Fire Windows.

1.4 DESIGN / PERFORMANCE REQUIREMENTS

- A. Fire Rated Assemblies: Provide assemblies complying with NFPA 80 and listed in UL Directory or Intertek Testing Services (Warnock Hersey Listed) Directory.

1.5 SUBMITTALS

- A. Submit under provisions of Section 01 33 00.
- B. Product Data: Manufacturer's data sheets on each product to be used, including:
 - 1. Preparation instructions and recommendations.
 - 2. Storage and handling requirements and recommendations.
 - 3. Details of construction and fabrication.
 - 4. Installation methods.
- C. Shop Drawings: Include detailed plans and elevations, details of framing members, anchoring methods, clearances, hardware, and accessories.
- D. Selection Samples: For each finish product specified, two complete sets of color chips representing manufacturer's full range of available colors and patterns.

- E. Verification Samples: For each finish product specified, two samples, minimum size 6 inches (150 mm) long, representing actual product, color, and patterns.
- F. Manufacturer's Certificates: Certify products meet or exceed specified requirements.
- G. Operation and Maintenance Data: Submit lubrication requirements and frequency, and periodic adjustments required.

1.6 QUALITY ASSURANCE

- A. Manufacturer Qualifications: Company specializing in performing Work of this section with a minimum of five years experience.
- B. Installer Qualifications: Installer Qualifications: Company approved by manufacturer, specializing in performing Work of this section with minimum three years experience, with IDEA Certified Installers and service technicians on staff.

1.7 DELIVERY, STORAGE, AND HANDLING

- A. Deliver, store, protect and handle products to site under provisions of Section 01 60 00.
- B. Store products in manufacturer's unopened packaging until ready for installation.
- C. Protect materials from exposure to moisture. Do not deliver until after wet work is complete and dry.
- D. Store materials in a dry, warm, ventilated weathertight location.

1.8 PROJECT CONDITIONS

- A. Maintain environmental conditions (temperature, humidity, and ventilation) within limits recommended by manufacturer for optimum results. Do not install products under environmental conditions outside manufacturer's absolute limits.

1.9 COORDINATION

- A. Coordinate Work with other operations and installation of adjacent materials to avoid damage to installed materials.

1.10 WARRANTY

- A. Manufacturer's Warranty: Provide manufacturer's two year limited warranty under the provisions of Section 01 78 00.
- B. Warranty: Manufacturer's limited door and operators System warranty of all parts and components of the system except counterbalance spring and finish for 3 years or 20,000 cycles, whichever comes first.

PART 2 PRODUCTS

2.1 MANUFACTURERS

- A. Acceptable Manufacturer: Overhead Door Corporation, 2501 S. State Hwy. 121, Suite 200, Lewisville, TX 75067. ASD. Tel. Toll Free: (800) 275-3290. Phone: (469) 549-7100. Fax: (972) 906-1499. Web Site: www.overheaddoor.com. E-mail: info@overheaddoor.com.
- B. Requests for substitutions will be considered in accordance with provisions of Section 01 60 00.

2.2 ROLLING FIRE SERVICE DOORS

- A. Rolling Fire Service Doors: FireKing Model 631 Fire Doors.
1. Label: Provide fire doors certified with the following listing.
 - a. Rolling fire doors up to 152 sf (14.12 sm) and not exceeding 13 feet 6 inches (4.11 m) in width or height shall receive the UL or ULC 3-Hour Class A Label for installation on masonry or steel jamb walls, face mounted or between jambs. Door may be welded to the face of steel jambs.
 2. Curtain: Interlocking roll-formed slats as specified following. Endlocks shall be attached to each end of alternate slats to prevent lateral movement.
 - a. Flat profile type F-265 for doors thru 14 feet (4.27 m) wide by 12 feet (3.65 m) high, fabricated of 24 gauge galvanized steel.
 3. Finish:
 - a. Galvanized Steel: Slats and hood galvanized steel to ASTM A 653 finished with a rust-inhibitive roll coating process, including bonderizing, a 0.2 mils thick baked prime paint, and a 0.6 mils thick baked top coat.
 - 1) Polyester Top Coat. Color selected by Architect from manufacturer's standard colors.
 - b. Non-galvanized exposed ferrous surfaces shall be black powder coated.
 4. Bottom Bar:
 - a. Two structural steel angles with PowderGuard Zinc Finish 1-1/2 inch by 1-1/2 inch by 1/8 inch (38 mm by 38 mm by 3 mm) minimum.
 5. Guides: Three structural steel angles.
 - a. Fastening Guides to Masonry Fire Walls: UL listed for fire in accordance with manufacturer's listing.
 6. Brackets: To support counterbalance, curtain and hood
 - a. Hot rolled steel to support counterbalance, curtain and hood.
 7. Finish: Bottom Bar, Guides, and Brackets.
 - a. Finish: Black powdercoat finish.
 8. Counterbalance: Helical torsion spring type housed in a steel tube or pipe barrel, supporting the curtain with deflection limited to 0.03 inch per foot of span. Counterbalance is adjustable by means of an adjusting tension wheel.
 9. Hood: 24 gauge galvanized primed steel. Provide one intermediate support bracket for wall openings over 13 feet 6 inches (4.11 m) wide.

10. Manual Operation:
 - a. Manual push.
11. Automatic Closure Standard Fire Door: UL approved release mechanism equipped with a 165 degree fusible link.
 - a. Doors will be equipped with chain hoist release mechanism, requiring only one sash chain to be routed to the operated side (sash chain not required to be routed to adjusting wheel side.)
 - 1) Release mechanism includes planetary gear differential system.
 - 2) Door will close by a thermally actuated link rated @165 degrees F, or by an optional listed releasing device, or by manually activating the release handle.
 - 3) All counterbalance spring tension shall be maintained when the release mechanism is activated.
 - 4) After closing by manual activation of the release handle, the door shall be able to be reset by one person from one side of the door (re-engaging the release handle). No tools shall be required to reset the release mechanism.
 - b. Fire Sentinel time-delay release mechanism provides an added measure of safety to control the doors' closure.
12. Governor: If required by the size for chain hoist doors, provide a viscous governor to regulate the rate of descent of door in a quiet manner. Use an engagement type that is not engaged during normal door operation, but after cable release, will retard the speed during automatic door closure to under 24 inches per second and not less than 6 inches per second per NFPA 80.
13. Wall Mounting Condition:
 - a. Between jambs mounting.

PART 3 EXECUTION

3.1 EXAMINATION

- A. Verify opening sizes, tolerances and conditions are acceptable.
- B. Examine conditions of substrates, supports, and other conditions under which this work is to be performed.
- C. If substrate preparation is the responsibility of another installer, notify Architect of unsatisfactory preparation before proceeding.

3.2 PREPARATION

- A. Clean surfaces thoroughly prior to installation.
- B. Prepare surfaces using the methods recommended by the manufacturer for achieving the best result for the substrate under the project conditions.

3.3 INSTALLATION

- A. Install in accordance with manufacturer's instructions.

- B. Install rolling counter fire doors in compliance with requirements of NFPA 80. Test fire-release system and reset components after testing.
- C. Use anchorage devices to securely fasten assembly to wall construction and building framing without distortion or stress.
- D. Securely and rigidly brace components suspended from structure. Secure guides to structural members only.
- E. Fit and align assembly including hardware; level and plumb, to provide smooth operation.
- F. Install and test Fire Sentinel release device in accordance with the manufacturer's instructions and in compliance with applicable regulations and codes of the local authority having jurisdiction.
- G. Coordinate installation of sealants and backing materials at frame perimeter as specified.
- H. Install perimeter trim and closures.

3.4 ADJUSTING

- A. Test for proper operation and adjust as necessary to provide proper operation without binding or distortion.
- B. Release device shall be tested and witnessed for proper operation with the door manufacturer recommendations
- C. Adjust hardware and operating assemblies for smooth and noiseless operation.

3.5 FIELD QUALITY CONTROL

- A. Functional testing of fire door and window assemblies shall be performed by IDEA Certified personnel with knowledge and understanding of the operating components of the type of door being subject to testing.

3.6 CLEANING

- A. Clean curtain and components using non-abrasive materials and methods recommended by manufacturer.
- B. Remove labels and visible markings.
- C. Touch-up, repair or replace damaged products before Substantial Completion.

3.7 PROTECTION

- A. Protect installed products until completion of project.

END OF SECTION

THIS PAGE INTENTIONALLY LEFT BLANK

SECTION 08 36 15

ALUMINUM & GLASS UPWARD-ACTING SECTIONAL DOORS

PART 1 - GENERAL

1.01 SUMMARY

- A. Related Documents:
The Drawings and general provisions of the Contract, including General and Supplementary General Conditions, and Division 1 Requirements, apply to the work in this Section.

1.02 SECTION INCLUDES

- A. Furnish and install all aluminum & glass upward-acting sectional doors, accessories and appurtenances, complete, in accordance with the specifications and drawings.

1.03 RELATED SECTIONS

- A. Section 05 50 00 - Miscellaneous Metal Work
- B. Section 09 91 00 - Painting; field painting.
- C. Division 26 - Electrical; wiring.

1.04 REFERENCES

- A. ANSI/DASMA 102 - American National Standard Specifications for Sectional Overhead Type Doors.

1.05 SUBMITTALS

- A. Submit product data and shop drawings under provisions of Section 01 33 00.
- B. Product Data: Submit manufacturer's product data and installation instructions for each type of sectional door. Include both published data and any specific data prepared for this project.
- C. Shop Drawings: Submit shop drawing for approval prior to fabrication. Include detailed plans, elevations, details of framing members, required clearances, anchors, and accessories. Include relationship with adjacent materials.
- D. Manufacturer's Certificates: Certify products meet or exceed specified requirements.
- E. Operation manual and Maintenance Data.
- F. Delegated-Design Submittal: For sectional doors indicated to comply with performance requirements, design criteria and local code, include analysis data signed and sealed by the qualified professional engineer responsible for their preparation.

1.06 QUALITY ASSURANCE

- A. Manufacturer: Sectional doors shall be manufactured by a firm with a minimum of five experience in the fabrication and installation of sectional doors.
- B. Installer: Installation of sectional doors shall be performed by the authorized representative of the manufacturer.
- C. Single-Source Responsibility: Provide doors, tracks, motors, and accessories from one manufacturer for each type of door. Provide secondary components from source acceptable to manufacturer of primary components.
- D. Pre-Installation Conference: Schedule and convene a pre-installation conference just prior to commencement of field operations, to establish procedures to maintain optimum working conditions and to coordinate this work with related and adjacent work.
- E. Products Requiring Electrical Connection: Listed and classified by Underwriters Laboratories, Inc. acceptable to authority having jurisdiction as suitable for purpose specified.
- F. Delegated Design: Design sectional doors, including comprehensive engineering analysis by a qualified professional engineer, using performance requirements, design criteria indicated and as required by the local code.
- G. Standard for Sectional Doors: Fabricate sectional doors to comply with DASMA 102 unless otherwise indicated.

1.07 DELIVERY, STORAGE, AND HANDLING

- A. Deliver, store and handle products to site under provisions of Section 01 60 00.
- B. Deliver materials and products in labeled protective packages. Store and handle in strict compliance with manufacturer's instructions and recommendations. Protect from damage from weather, excessive temperatures & moisture and construction operations.

1.08 FIELD MEASUREMENTS

- A. Verify that field measurements are as existing in the field and as indicated on the shop drawings prior to fabrication.

1.09 WARRANTY

- A. Submit under provisions of Section 01 78 00.
- B. Manufacturer's standard form warranty in which manufacturer agrees to repair or replace components of sectional doors that fail in materials or workmanship within specified warranty period.
 - 1. Failures include, but are not limited to, the following:
 - a. Structural failures including, but not limited to, excessive deflection.
 - b. Faulty operation of hardware.

- c. Deterioration of metals, metal finishes, and other materials beyond normal weathering and use; rust through.
 - d. Delamination of exterior or interior facing materials.
 2. Warranty Period: 10 years from date of Substantial Completion.
- C. Finish Warranty: Manufacturer's standard form warranty in which manufacturer agrees to repair or replace components that show evidence of deterioration of factory-applied finishes within specified warranty period.

PART 2 - PRODUCTS

2.01 MANUFACTURERS

- A. Subject to compliance with requirements of this Specification Section, provide products listed herein from one of the following:
1. Ceco/Windsor Door
 2. The Cookson Company
 3. Overhead Door Corporation
- B. Basis of Design: Overhead Door Corporation, 521 Series Aluminum Doors
- C. Substitutions: Under provisions of Section 01 60 00.

2.02 COMPONENTS

- A. Provide and install Glazed Sectional Overhead Doors:
Quantity: Nine (9)
1. Door Assembly: Stile and rail assembly secured with 1/4 inch diameter through rods.
 2. Units to have the following characteristics:
 - a. Panel Thickness: 1-3/4 inches.
 - b. Center Stile Width: 2-11/16 inches
 - c. End Stile Width: 3-5/16 inches
 - d. Intermediate Rail Pair Width: 3-11/16 inches
 - e. Top Rail Width: 3-3/4 inches.
 - f. Bottom Rail Width: 4-1/2 inches.
 - g. Aluminum Panels: 0.050 inch thick, aluminum.
 - h. Stiles and Rails: 6063 - T6 aluminum.
 - i. Provide high usage package.
 - j. Spring Counterbalance: Sized to weight of the door, with a helically wound, oil tempered torsion spring mounted on a steel shaft; cable drum of diecast aluminum with high strength galvanized aircraft cable. Sized with a minimum 7 to 1 safety factor. High cycle spring: Not less than 100,000 cycles.
 - k. All rails and stiles are to be filled with polyurethane insulation.
 - l. Provide structural reinforcement on the door as required to meet wind loads per state building code.
- B. Finish and Color:
- Provide powder coat finish on interior and exterior in colors selected by Architect from manufacturer's standard powder coat colors. Interior and exterior will be different colors.

- C. Openings
1. Windows:
 - Provide 1/2 inch, tempered, insulating glass. Gray tint. Shade of gray tint to be selected by Architect from manufacturer's standards.
- D. Windload Design: ANSI/NAGDM 102 standards and as required by state code.
1. Wind Loads: Uniform pressure (velocity pressure): Per Building Code
 - a. Provide wind load rated door as required to meet state code requirements.
 - b. Must meet requirements for basic 138 mph wind speed zone.
 - c. Importance Factor: Per Building Code
 - d. Exposure Category: Per Building Code
 2. Deflection Limits: Design sectional doors to withstand design wind loads without evidencing permanent deformation or disengagement of door components. Deflection of door in horizontal position (open) shall not exceed 1/120 of the door width.
- E. Operation Cycles: Provide sectional door components and operators capable of operating for not less than number of cycles indicated for each door. One operation cycle is complete when a door is opened from the closed position to the fully open position and returned to the closed position.
- F. Hardware: Galvanized steel integral hinges and fixtures. Ball bearing rollers with hardened steel races.
- G. Counterbalance Mechanism
1. Torsion Spring: Counterbalance mechanism consisting of adjustable-tension torsion springs fabricated from steel- spring wire complying with ASTM A 229/A 229M, mounted on torsion shaft made of steel tube or solid steel. Provide springs designed for number of operation cycles indicated.
 2. Weight Counterbalance: Counterbalance mechanism consisting of filled pipe weights that move vertically in a galvanized-steel weight pipe. Connect pipe weights with cable to weight-cable drums mounted on torsion shaft made of steel tube or solid steel.
 3. Cable Drums and Shaft for Doors: Cast-aluminum or gray-iron casting cable drums mounted on torsion shaft and grooved to receive door-lifting cables as door is raised. Mount counterbalance mechanism with manufacturer's standard ball-bearing brackets at each end of torsion shaft. Provide one additional midpoint bracket for shafts up to 16 feet (4.88 m) long and two additional brackets at one-third points to support shafts more than 16 feet (4.88 m) long unless closer spacing is recommended by door manufacturer.
 4. Cables: Galvanized-steel lifting cables with cable safety factor of at least 7 to 1.
 5. Cable Safety Device: Include a spring-loaded steel or spring-loaded bronze cam mounted to bottom door roller assembly on each side and designed to automatically stop door if either lifting cable breaks.
 6. Bracket: Provide anchor support bracket as required to connect stationary end of spring to the wall and to level the shaft and prevent sag.
- H. Weatherstripping:
1. EPDM bulb-type strip at bottom.
 2. Flexible header and jamb weatherstripping.
 3. Weatherstripping to be replaceable, adjustable, continuous, and compressible gaskets

- I. Track:
1. Size: 3 inch galvanized steel
 2. Provide lift clearance track or low headroom track as required.
 3. Provide complete track assembly including brackets, bracing, and reinforcement for rigid support of ball-bearing roller guides for required door type and size. Slot vertical sections of track spaced 2 inches (51 mm) apart for door-drop safety device. Slope tracks at proper angle from vertical or design tracks to ensure tight closure at jambs when door unit is closed.
 4. Track Reinforcement and Supports: Galvanized-steel track reinforcement and support members, complying with ASTM A 36/A 36M and ASTM A 123/A 123M. Secure, reinforce, and support tracks as required for door size and weight to provide strength and rigidity without sag, sway, and vibration during opening and closing of doors.
- J. Electric Motor Operation:
1. General: Electric door operator assembly provided by door manufacturer with electric motor and factory-rewired motor controls, starter, gear-reduction unit, solenoid-operated brake, clutch, remote-control stations, control devices, integral gearing for locking door, and accessories required for proper operation.
 - a. Comply with NFPA 70.
 - b. Provide control equipment complying with NEMA ICS 1, NEMA ICS 2, and NEMA ICS 6; with NFPA 70, Class 2 control circuit, maximum 24-V ac or dc.
 2. Usage Classification: Electric operator and components capable of operating for not less than number of cycles per hour indicated for each door.
 3. Door-Operator Type: Unit consisting of electric motor, gears, pulleys, belts, sprockets, chains, and controls needed to operate door and meet required usage classification.
 - a. Trolley: Trolley operator mounted to ceiling above and to rear of door in raised position and directly connected to door with drawbar.
 4. Electric Motors: Comply with NEMA requirements.
 - a. Electrical Characteristics:
 1. Model RSX Commercial Door Operator
 2. Provide UL listed electric motor, 1 horsepower, 208/230V, 60 HZ, three phase.
 - b. Motor Type and Controller: Reversible motor and controller (disconnect switch) for motor exposure indicated.
 - c. Operating Controls, Controllers (Disconnect Switches), Wiring Devices, and Wiring: Manufacturer's standard unless otherwise indicated.
 - d. Coordinate wiring requirements and electrical characteristics of motors and other electrical devices with building electrical system and each location where installed.
 - e. Use adjustable motor-mounting bases for belt-driven operators.
 5. Limit Switches: Equip each motorized door with adjustable switches interlocked with motor controls and set to automatically stop door at fully opened and fully closed positions.
 6. Obstruction Detection Device: Equip motorized door with external automatic safety sensor capable of protecting full width of door opening. Activation of device immediately stops and reverses downward door travel.
 - a. Entrapment Protection: Electric sensing edge monitored to meet UL 325/20107.
 7. Remote-Control Station: Momentary-contact, three-button control station with push-button controls labeled "Open," "Close," and "Stop" with on/off key switch operation.
 - a. Interior units, full-guarded, surface-mounted, heavy-duty type, with general-purpose NEMA ICS 6, Type 1 enclosure.
 1. Quantity: Provide one control station adjacent to each of the overhead

- doors on the interior.
- 2. Verify exact locations with Architect prior to installation.
- b. Exterior: None required

- K. Emergency Manual Operation: Equip each electrically powered door with capability for emergency manual operation. Design manual mechanism so required force for door operation does not exceed 25 lbf.

- L. Emergency Operation Disconnect Device: Do not include.

- M. Motor Removal: Design operator so motor may be removed without disturbing limit-switch adjustment and without affecting emergency manual operation.

- N. Audible and Visual Signals: Audible alarm and visual indicator lights in compliance with regulatory requirements for accessibility.

PART 3 - EXECUTION

3.01 PREPARATION

- A. Take field dimensions and examine conditions of substrates, supports, and other conditions under which this work is to be performed. Do not proceed with work until unsatisfactory conditions are corrected.

3.02 INSTALLATION

- A. Install overhead doors and track in accordance with approved shop drawings and the manufacturer's printed instructions.
- B. Coordinate installation with adjacent work to ensure proper clearances and allow for maintenance.
- C. Anchor assembly to wall construction and building framing without distortion or stress.
- D. Securely brace door tracks suspended from structure. Secure tracks to structural members only.
- E. Fit and align door assembly including hardware.
- F. Coordinate installation of electrical service. Complete power and control wiring from disconnect to unit components.
- G. Instruct Owners personnel in proper operating procedures and maintenance schedule.
- H. Tracks:
 - 1. Fasten vertical track assembly to opening jambs and framing, spaced not more than 24 inches apart.
 - 2. Hang horizontal track assembly from structural overhead framing with angles or channel hangers attached to framing by welding or bolting, or both. Provide sway bracing, diagonal bracing, and reinforcement as required for rigid installation of track and door-operating equipment.

3. Install horizontal track height as shown on drawings.
4. Repair galvanized coating on tracks according to ASTM A 780.

3.03 STARTUP SERVICES

- A. Engage a factory-authorized service representative to perform startup service.
 1. Complete installation and startup checks according to manufacturer's written instructions.
 2. Test and adjust controls and safeties. Replace damaged and malfunctioning controls and equipment.

3.04 ADJUSTING AND CLEANING

- A. Adjust hardware and moving parts to function smoothly so that doors operate easily, free of warp, twist, or distortion.
- B. Lubricate bearings and sliding parts as recommended by manufacturer.
- C. Adjust doors and seals to provide weathertight fit around entire perimeter.
- D. Align and adjust motors, pulleys, belts, sprockets, chains, and controls according to manufacturer's written instructions.
- E. Touch-up Painting: Immediately after welding galvanized materials, clean welds and abraded galvanized surfaces and repair galvanizing to comply with ASTM A 780.
- F. Remove temporary labels and clean exposed surfaces using non-abrasive materials and methods recommended by manufacturer of material or product being cleaned.
- G. Clean work under provisions of Section 01 70 00.

3.05 DEMONSTRATION

- A. Engage a factory-authorized service representative to train Owner's maintenance personnel to adjust, operate, and maintain sectional doors.

3.06 PROTECTION OF FINISHED WORK

- A. Protect finished work under provisions of Section 01 70 00.
- B. Touch-up, damaged coatings and finishes and repair minor damage before Substantial Completion.

3.07 SCHEDULE

This style door is to be provided at door openings B100a through B100h and B100k.

END OF SECTION

THIS PAGE INTENTIONALLY LEFT BLANK

SECTION 08 42 13

ALUMINUM ENTRANCE DOORS

PART 1 GENERAL

1.01 WORK INCLUDED

- A. Furnish and install aluminum entrance, entrance door frames complete with hardware, and related components as shown on the drawings and specified in this section.
- B. Glass and Glazing
 - 1. Reference Section 08 81 00 for Glass and Glazing.

1.02 RELATED WORK

- A. Section 08 43 13 – Aluminum Storefront System
- B. Section 08 43 15 - Aluminum Storefront System - Non-Thermal

1.03 ITEMS INSTALLED BUT NOT FURNISHED

- A. Structural support of the framing, wood framing and structural steel.

1.04 TESTING AND PERFORMANCE REQUIREMENTS

- A. Test Units
 - 1. Air test unit shall be minimum size of 3'-0" x 7'-0".
- B. Test Procedures and Performances
 - 1. Entrance doors shall conform to all requirements for the door type specified. In addition, the following specific performance requirements shall be met.
 - 2. Air Infiltration Test
 - a. With door closed and locked, test unit in accordance with ASTM E 283 at a static air pressure difference of 1.57 psf.
 - b. Air infiltration shall not exceed .50 cfm per foot of perimeter crack length for single doors.
 - c. Air infiltration shall not exceed .10 cfm per foot of perimeter crack length for a pair of doors.

1.05 QUALITY ASSURANCE

- A. Provide test reports from laboratories certifying the performance as specified.
- B. Test reports shall be accompanied by the entrance door manufacturer's letter of certification stating that the tested door meets or exceeds the referenced performance standard for the appropriate door type.

1.06 QUALIFICATIONS

- A. Manufacturer and installer must have specialized in performing the work of this section with a minimum of five (5) years documented experience. Installer must be approved by the manufacturer.

1.07 REGULATORY REQUIREMENTS

- A. Conform to all Federal, State, and Local Codes.

1.08 SUBMITTALS

- A. Submit shop drawings, manufacturer's installation instructions, product data and finish samples under provisions of Section 01 33 00.
- B. Indicate frame configuration, anchor types and spacings, reinforcements, and finish.
- C. Indicate door elevations, closure method, glazing connection, and all accessories.
- D. Provide returnable sample as required by the Architect.

1.09 DELIVERY, STORAGE, AND HANDLING

- A. Protect products under provisions of Section 01 60 00.

1.10 WARRANTIES

- A. Total Entrance Door / Storefront System
 - 1. Provide warranty under provisions of Section 01 78 00.
 - 2. The responsible contractor shall assume full responsibility and warrant for one year the satisfactory performance of the total entrance door installation which includes that of the doors, hardware, glass (including insulated units), glazing, anchorage and setting system, sealing, flashing, etc., as it relates to air and structural adequacy as called for in the specifications and approved shop drawings.
 - 3. Any deficiencies due to such elements not meeting the specifications shall be corrected by the responsible contractor at his expense during the warranty period.
- B. Provide written warranty stating organic coating finish will be free from fading more than 10%, chalking, peeling, chipping, or cracking for 15 years from date of Substantial Completion.

PART 2 PRODUCTS

2.01 MANUFACTURERS

- A. All doors shall be EFCO Series D518 DuraStile Wide Stile Entrance Door and Frame.
- B. Other acceptable manufacturers offering equivalent products.
 - 1. Kawneer Company
 - 2. Oldcastle Building Envelope

- C. Single source requirement: Storefront, and entrance doors are to be from a single manufacturer.

2.02 MATERIALS

A. Aluminum

1. Extruded aluminum shall be 6063-T6 alloy and temper.

B. Fasteners

1. All exposed fasteners shall be aluminum or stainless steel.

2.03 FABRICATION

A. General

1. Major portions of the door sections shall have .188" wall thickness. Glazing stop sections shall have .050" wall thickness.

B. Entrance Doors

1. Door stiles shall be no less than 5" wide (not including glass stops).
2. Bottom rail of door shall be no less than 10" (not including glass stops).
2. Door stiles and rails shall have hairline joints at corners. Heavy concealed reinforcement brackets shall be secured with screws and shall be of deep penetration and fillet welded.
3. Weather stripping shall be wool pile and shall be installed in one stile of door pairs and in jamb stiles of center pivoted doors.

C. Door stops shall include EPDM bulb weather stripping.

D. Glazing

1. All units shall be dry glazed with extruded pressure fitting aluminum glazing stops, and EPDM gasket.
2. Glazing shall be glass as specified in Section 08 81 00.

E. Door Frame

1. Depth of frame shall not be less than 4 1/2".
2. Face dimension shall not be less than 2".
3. Frame components shall have .188" wall thickness.
4. Shear block construction shall be utilized throughout.
5. System design shall be such that raw edges will not be visible at joints.

F. Finish

1. Organic
 - a. Finish all exposed areas of aluminum doors and components with AA-M12-C42-R1X, 70% PVDF Ultrapon meeting AAMA 2605.
 - b. Color shall be as selected by Architect from manufacturer's standard colors.
2. Color shall be as selected by Architect from manufacturer's standard colors.

2.04 HARDWARE

- A. All doors shall be equipped with a concealed vertical rod exit device or rim exit device with the release mechanism contained in a 7" mid-rail. The release mechanism shall be clearly marked,

with the word "PUSH" but shall not extend more than 1" beyond the plane of the door in the unactivated position. Doors shall have Ultraline offset pull handle on the exterior. Provide key cylinder dog-down.

1. Provide, where noted on the drawings, an electric strike for a rim exit device or an electrified latch retraction system for concealed vertical rod exit devices as required for a remote unlocking of the doors noted.
Provide and install all wiring and power supplies or transformers as required for a complete operating system.
Provide and connect to new Proximity Reader by Seco-Larm USA, Inc. (or equal) Model PR-2125-PQ Standard Wiegand Reader, weatherproof access control proximity card and fob reader.
 2. Hardware as listed on Door Schedule.
 - a. Hardware Set 1 has a Proximity Reader
 - b. Hardware Set 2 does not have a Proximity Reader
- B. Hinges to be full height continuous Roton Model 780-112 HD or equal. Finish to match door.
- C. Closers to be standard manufacturer's concealed type with a limiting stop and a hold open. Closer must meet the state code for opening force and swing position.
- D. Provide standard weatherstripping. See Section 08 71 50 for sweep and threshold.

PART 3 EXECUTION

3.01 INSPECTION

- A. Job Conditions
1. Verify that openings are dimensionally within allowable tolerances, plumb, level, clean, provide a solid anchoring surface and are in accordance with approved shop drawings.

3.02 INSTALLATION

- A. Use only skilled tradesmen with work done in accordance with approved shop drawings and specifications.
- B. Plumb and align entrance door faces in a single plane for each wall plane and erect doors and materials square and true. Adequately anchor to maintain positions permanently when subjected to normal thermal movement, specified building movement, and specified wind loads.
- C. Adjust doors for proper operation after installation.
- D. Furnish and apply sealants to provide a weather tight installation at all joints and intersections and at opening perimeters. Wipe off excess material and leave all exposed surfaces and joints clean and smooth.

3.03 CLEANING

- A. Entrance doors shall be inspected, adjusted, put into working order and left clean, free of labels, dirt, etc.

- B. The Contractor shall be responsible for cleaning all aluminum, employing methods recommended by the manufacturer as follows: Anodized aluminum shall be cleaned with plain water containing a mild detergent, or a petroleum product such as white gasoline, kerosene, or distillate. No abrasive agent shall be used.
- C. Glass shall be cleaned thoroughly.

3.04 PROTECTION OF FINISHED WORK

- A. Protect finished work under provisions of Section 01 70 00.

END OF SECTION

THIS PAGE INTENTIONALLY LEFT BLANK

SECTION 08 43 13

ALUMINUM STOREFRONT SYSTEM

PART 1 - GENERAL

1.01 SECTION INCLUDES

- A. Furnish and install aluminum architectural storefront system complete with hardware and related components as shown on drawings and specified in this section.

1.02 RELATED WORK

- A. Section 08 81 00 – Glass and Glazing
- B. Section 08 42 13 – Aluminum Entrance doors
- C. Section 08 43 15 - Aluminum Storefront System - Non-Thermal

1.03 TESTING AND PERFORMANCE REQUIREMENTS

- A. Provision for Thermal Movements
 - 1. Storefront framing systems shall be designed to provide for thermal movement of all component materials resulting from a surface temperature change of 180 degrees F without causing buckling, stresses on glass, failure of joint seals, undue stress on structural elements, damaging loads on fasteners, reduction of performance, or other detrimental effects. Operating windows and doors shall function normally over this temperature range.
- B. Test Procedures and Performance
 - 1. Air Infiltration Test
 - a. Test unit in accordance with ASTM E 283 at a static air pressure difference of 6.24 psf.
 - b. Air infiltration shall not exceed .06 cfm per square foot of fixed wall area.
 - 2. Water Resistance Test
 - a. Test unit in accordance with ASTM E 331.
 - b. There shall be no uncontrolled water leakage at a static test pressure of 12.0 psf.
 - 3. Uniform Load Deflection Test
 - a. Test in accordance with ASTM E 330.
 - b. The system shall withstand wind pressure normal to the plane of the wall in accordance with all applicable state and local codes.
 - c. Deflection under design load shall not exceed L/175 of the clear span.
 - 4. Uniform Load Structural Test
 - a. Test in accordance with ASTM E 330 at a pressure 1.5 times the denoted design wind pressure.
 - b. At conclusion of the test, there shall be no glass breakage, permanent damage to fasteners, storefront parts, or any other damage that would cause the storefront to be defective.
 - 5. Condensation Resistance Test (CRF)
 - a. Test unit in accordance with ASTM 1503.1.
 - b. Condensation Resistance Factor (CRF) shall not be less than 59.
 - 6. National Fenestration Rating Council (NFRC)
 - a. NFRC 100; Procedure for Determining Fenestration Thermal Properties:

The conductive thermal transmittance (U-Factor) shall not be more than 0.38 BTU/hr/sf/°F when glazed with 1" insulated – 1/4" clear, 1/2" air, 1/4" clear low emissivity glass.

- b. NFRC 200; Solar Heat Gain Coefficient and Visible Transmittance:
Solar Heat Gain Coefficient (SHGC): 0.40

1.04 ENGINEERING REQUIREMENTS

- A. Systems shall be engineered to the following requirements and evidence, in the form of drawings and calculations, shall be delivered to the Architect for approval. All calculations and drawings shall be approved and stamped by a registered engineer.
 - 1. Window wall framing members to be designed to withstand 30 psf positive and 30 psf negative wind loads up to and including a 50 foot height above ground and increasing acting normal to plane of wall.
 - 2. Wall so constructed as to provide for such expansion and/or contraction of component materials as will be caused by an ambient temperature range of 140 degrees f. without causing harmful buckling, failure of joint seals, and undue stress on fasteners or other detrimental effects.
 - 3. The calculated deflection of any metal framing member in a directional normal to the plane of the wall shall not exceed 1/175'th of it's clear span or 3/4 inch, whichever is less, except that when a finished plaster type surface is affected, the deflection shall not exceed 1/360'th of the span.
- B. Design, engineer, fabricate and install the curtain wall system to withstand the effects of wind loading specified with no material failures or permanent deformation of structural members.
- C. Structural test pressure shall be equal to 150 percent of the inward and outward acting design wind pressures.

1.05 QUALITY ASSURANCE

- A. Provide test reports from AAMA accredited laboratories certifying the performance as specified in.
- B. Test reports shall be accompanied by the storefront manufacturer's letter of certification stating that the tested storefront meets or exceeds the referenced criteria for the appropriate storefront type.

1.06 REFERENCES

- A. AAMA - American Architectural Manufacturer's Association.
- B. ASTM - American Society for Testing and Materials.

1.07 SUBMITTALS

- A. Submit under provisions of Section 01 33 00.
- B. Drawings shall show scale elevations and sections. Full size sections shall be shown only when needed for clarity. Drawings shall show construction of all parts of the work, including metal and glass thickness, methods of joining, details of all field connections and anchorage, fastening and sealing methods, metal finishes and all pertinent information. Relationship to other work should be

clearly indicated. No work shall be fabricated until shop drawings for that work have been finally approved for fabrication.

- C. Contractor shall submit finish samples, test reports, and warranties.
 - 1. Samples of materials as may be requested by the Architect without cost to owner, i.e., metal, glass, fasteners, anchors, frame sections, mullion section, corner section, etc.

1.08 QUALIFICATIONS

- A. Manufacturer: Company specializing in manufacturing aluminum storefront systems with minimum five years of experience.
- B. Installer: A commercial glazer with not less than five years of experience installing similar glazing systems and approved by the system manufacturer.

1.09 DELIVERY, STORAGE, AND HANDLING

- A. Deliver, store, protect and handle products to site under provisions of Section 01 60 00.
- B. Accept window units on site in original cartons. Inspect for damage.
- C. Protect window units from damage by other trades and damage to finish.

1.10 FIELD MEASUREMENTS

- A. Verify that field measurements are as indicated on shop drawings.

1.11 WARRANTIES

- A. Provide five year warranty under provisions of Section 01 78 00.
- B. Include coverage for repair or replacement of any defective units or materials, to the satisfaction of and at no cost to the owner. Failure includes but is not limited to water leakage, excessive air infiltration, excessive deflections, faulty operation of sash or deterioration of the finish in excess of normal weathering and defects in hardware, weatherstripping and all other components of the completed project.
- C. Include coverage from the insulating glass manufacturer agreeing to replace, at no cost to the owner, any sealed insulating glass units which fail within ten (10) years of manufacture. Failure shall include but not be limited to fog, mist, condensation, or dust which appears on the #2 or #3 surfaces of the insulated glass unit.
- D. Provide written warranty stating organic coating finish will be free from fading more than 10%, chalking, peeling, chipping, or cracking for 15 years from date of Substantial Completion.

PART 2 - PRODUCTS

2.01 MANUFACTURERS

- A. EFCO System 403 Thermal, Screw Spline Storefront
- B. Other acceptable manufacturers offering equivalent products.
 - 1. Kawneer Company
 - 2. Oldcastle Building Envelope
- C. Single source requirement: Storefront and entrance doors are to be from a single manufacturer.

2.02 MATERIALS

- A. Aluminum
 - 1. Extruded aluminum shall be 6063-T6 alloy and temper.
- B. Glass
 - 1. Glazing shall be glass as specified in Section 08 81 00.
- C. Dissimilar Metals
 - 1. All dissimilar metals must be properly insulated to prevent galvanic action.
- D. Fasteners
 - 1. All exposed fasteners shall be aluminum or stainless steel.
- E. Thermal Barrier
 - 1. Barrier material shall be poured in place, two-part polyurethane. A nonstructural thermal barrier is unacceptable.

2.03 FABRICATION

- A. General
 - 1. All aluminum frame extrusions shall have a minimum wall thickness of .080".
 - 2. All exposed work shall be carefully matched to produce continuity of line and design with all joints. System design shall be such that raw edges will not be visible at joints.
- B. Frame
 - 1. Depth of frame shall not be less than 4 1/2".
 - 2. Face dimension shall not be less than 2".
 - 3. Frame components shall be screw spline construction.
- C. Glazing
 - 1. All units shall be "dry glazed" with EPDM gasket on both exterior and interior.
- D. Interior trim, closures, angles and the like shall be of sizes and shapes as shown with fastenings as required and/or specified. All snap-on design trim shall be in 0.062 inch minimum thickness. Trim shall connect to extruded aluminum anchors which shall permit the window to be anchored without

the use of fasteners thru frame which may permit air or water leakage. Trim shall be of adequate size to cover all exposed areas and to preclude painting due to installation of new materials.

- E. Exterior panning – aluminum, 0.078 inch thickness to cover all existing window framing or areas as noted on drawings; one piece design to abut or interlock into window frames without use of exposed fasteners; weathertight connection to allow for expansion and contraction.
- F. Set trim in full bed of sealant and seal all corners of panning trim from inside or with clear silicone ribbon from exterior. Leave installation in a clean, neat condition.
- G. Frame Finish
 - 1. Organic
 - a. Finish all exposed areas of aluminum doors and components with AA-M12-C42-R1X, 70% PVDF Ultrapon meeting AAMA 2605.
 - b. Color shall be as selected by Architect from manufacturer's standard colors.

PART 3 - EXECUTION

3.01 INSPECTION

- A. Job Conditions
 - 1. All openings shall be prepared by others to the proper size and shall be plumb, level and in the proper location and alignment as shown on the architect's drawings.

3.02 INSTALLATION

- A. Strictly comply with manufacturer's instructions and recommendations. Match profiles, sizes and spacings indicated on approved shop drawings. Do not perform structural silicone sealant work when the metal temperature is below 32 degrees F.
- B. Storefront system shall be erected plumb and true, in proper alignment and relation to established lines and grades.
- C. Entrance doors shall be securely anchored in place to a straight, plumb and level condition, without distortion. Weather stripping contact and hardware movement shall be checked and final adjustments made for proper operation and performance of units.
- D. Furnish and apply sealing materials to provide a weather tight installation at all joints and intersections and at opening perimeters.
- E. Sealing materials specified shall be used in strict accordance with the manufacturer's printed instructions, and shall be applied only by mechanics specially trained or experienced in their use. All surfaces must be clean and free of foreign matter before applying sealing materials. Sealing compounds shall be tooled to fill the joint and provide a smooth finished surface.
- F. Coordinate installation with adjacent work to ensure creation of a complete weatherproof assembly. Anchor work securely to supporting structure, but allow for differential and thermal movement.
- G. Isolate between aluminum and dissimilar metals with a protective coating or plastic strip to prevent electrolytic corrosion.

3.03 ANCHORAGE

- A. Adequately anchor to maintain positions permanently when subjected to normal thermal movement, specified building movement, and specified wind loads.
- B. Provide fasteners as recommended by the manufacturer for the type of substrate the window system is to be anchored.

3.04 CLEANING AND PROTECTION

- A. During installation, remove labels, part number markings, sealant smears, handprints, and construction dirt from all components.
- B. Touch-up damaged coatings and finishes and repair minor damage to eliminate all evidence of repair. Remove and replace work which cannot be satisfactorily repaired.
- C. Clean all exposed surfaces including metal and glass using non-abrasive materials and methods recommended by manufacturer of material or product being cleaned. Remove and replace work that cannot be successfully cleaned.
- D. The general contractor shall protect the aluminum materials and finish against damage from construction activities and harmful substances.

END OF SECTION

SECTION 08 43 15

ALUMINUM STOREFRONT SYSTEM
(Non Thermal)

PART 1 - GENERAL

1.01 SECTION INCLUDES

- A. Furnish and install aluminum architectural non-thermal storefront system complete with hardware and related components as shown on drawings and specified in this section.

1.02 RELATED WORK

- A. Section 08 81 00 – Glass and Glazing
- B. Section 08 42 13 – Aluminum Entrance doors
- C. Section 08 43 13 - Aluminum Storefront System - Thermal

1.03 TESTING AND PERFORMANCE REQUIREMENTS

- A. Provision for Thermal Movements
 - 1. Storefront framing systems shall be designed to provide for thermal movement of all component materials resulting from a surface temperature change of 180 degrees F without causing buckling, stresses on glass, failure of joint seals, undue stress on structural elements, damaging loads on fasteners, reduction of performance, or other detrimental effects. Operating windows and doors shall function normally over this temperature range.
- B. Test Procedures and Performance
 - 1. Air Infiltration Test
 - a. Test unit in accordance with ASTM E 283 at a static air pressure difference of 6.24 psf.
 - b. Air infiltration shall not exceed .06 cfm per square foot of fixed wall area.
 - 2. Water Resistance Test
 - a. Test unit in accordance with ASTM E 331.
 - b. There shall be no uncontrolled water leakage at a static test pressure of 12.0 psf.
 - 3. Uniform Load Deflection Test
 - a. Test in accordance with ASTM E 330.
 - b. The system shall withstand wind pressure normal to the plane of the wall in accordance with all applicable state and local codes.
 - c. Deflection under design load shall not exceed L/175 of the clear span.
 - 4. Uniform Load Structural Test
 - a. Test in accordance with ASTM E 330 at a pressure 1.5 times the denoted design wind pressure.
 - b. At conclusion of the test, there shall be no glass breakage, permanent damage to fasteners, storefront parts, or any other damage that would cause the storefront to be defective.

5. National Fenestration Rating Council (NFRC)
 - a. NFRC 100; Procedure for Determining Fenestration Thermal Properties:
The conductive thermal transmittance (U-Factor) shall not be more than 0.38 BTU/hr/sf/°F when glazed with 1" insulated – 1/4" clear, 1/2" air, 1/4" clear low emissivity glass.
 - b. NFRC 200; Solar Heat Gain Coefficient and Visible Transmittance:
Solar Heat Gain Coefficient (SHGC): 0.40

1.04 ENGINEERING REQUIREMENTS

- A. Systems shall be engineered to the following requirements and evidence, in the form of drawings and calculations, shall be delivered to the Architect for approval. All calculations and drawings shall be approved and stamped by a registered engineer.
 1. Window wall framing members to be designed to withstand 30 psf positive and 30 psf negative wind loads up to and including a 50 foot height above ground and increasing acting normal to plane of wall.
 2. Wall so constructed as to provide for such expansion and/or contraction of component materials as will be caused by an ambient temperature range of 140 degrees f. without causing harmful buckling, failure of joint seals, and undue stress on fasteners or other detrimental effects.
 3. The calculated deflection of any metal framing member in a directional normal to the plane of the wall shall not exceed 1/175'th of it's clear span or 3/4 inch, whichever is less, except that when a finished plaster type surface is affected, the deflection shall not exceed 1/360'th of the span.
- B. Design, engineer, fabricate and install the curtain wall system to withstand the effects of wind loading specified with no material failures or permanent deformation of structural members.
- C. Structural test pressure shall be equal to 150 percent of the inward and outward acting design wind pressures.

1.05 QUALITY ASSURANCE

- A. Provide test reports from AAMA accredited laboratories certifying the performance as specified in.
- B. Test reports shall be accompanied by the storefront manufacturer's letter of certification stating that the tested storefront meets or exceeds the referenced criteria for the appropriate storefront type.

1.06 REFERENCES

- A. AAMA - American Architectural Manufacturer's Association.
- B. ASTM - American Society for Testing and Materials.

1.07 SUBMITTALS

- A. Submit under provisions of Section 01 33 00.
- B. Drawings shall show scale elevations and sections. Full size sections shall be shown only when needed for clarity. Drawings shall show construction of all parts of the work, including metal and

glass thickness, methods of joining, details of all field connections and anchorage, fastening and sealing methods, metal finishes and all pertinent information. Relationship to other work should be clearly indicated. No work shall be fabricated until shop drawings for that work have been finally approved for fabrication.

- C. Contractor shall submit finish samples, test reports, and warranties.
 - 1. Samples of materials as may be requested by the Architect without cost to owner, i.e., metal, glass, fasteners, anchors, frame sections, mullion section, corner section, etc.

1.08 QUALIFICATIONS

- A. Manufacturer: Company specializing in manufacturing aluminum storefront systems with minimum five years of experience.
- B. Installer: A commercial glazer with not less than five years of experience installing similar glazing systems and approved by the system manufacturer.

1.09 DELIVERY, STORAGE, AND HANDLING

- A. Deliver, store, protect and handle products to site under provisions of Section 01 60 00.
- B. Accept window units on site in original cartons. Inspect for damage.
- C. Protect window units from damage by other trades and damage to finish.

1.10 FIELD MEASUREMENTS

- A. Verify that field measurements are as indicated on shop drawings.

1.11 WARRANTIES

- A. Provide five year warranty under provisions of Section 01 78 00.
- B. Include coverage for repair or replacement of any defective units or materials, to the satisfaction of and at no cost to the owner. Failure includes but is not limited to water leakage, excessive air infiltration, excessive deflections, faulty operation of sash or deterioration of the finish in excess of normal weathering and defects in hardware, weatherstripping and all other components of the completed project.
- C. Include coverage from the insulating glass manufacturer agreeing to replace, at no cost to the owner, any sealed insulating glass units which fail within ten (10) years of manufacture. Failure shall include but not be limited to fog, mist, condensation, or dust which appears on the #2 or #3 surfaces of the insulated glass unit.
- D. Provide written warranty stating organic coating finish will be free from fading more than 10%, chalking, peeling, chipping, or cracking for 15 years from date of Substantial Completion.

PART 2 - PRODUCTS

2.01 MANUFACTURERS

- A. EFCO System 402 non-thermal, Screw Spline Storefront
- B. Other acceptable manufacturers offering equivalent products.
 - 1. Kawneer Company
 - 2. Oldcastle Building Envelope
- C. Single source requirement: Storefront and entrance doors are to be from a single manufacturer.

2.02 MATERIALS

- A. Aluminum
 - 1. Extruded aluminum shall be 6063-T6 alloy and temper.
- B. Glass
 - 1. Glazing shall be glass as specified in Section 08 81 00.
- C. Dissimilar Metals
 - 1. All dissimilar metals must be properly insulated to prevent galvanic action.
- D. Fasteners
 - 1. All exposed fasteners shall be aluminum or stainless steel.
- E. Thermal Barrier
 - 1. Barrier material shall be poured in place, two-part polyurethane. A nonstructural thermal barrier is unacceptable.

2.03 FABRICATION

- A. General
 - 1. All aluminum frame extrusions shall have a minimum wall thickness of .080".
 - 2. All exposed work shall be carefully matched to produce continuity of line and design with all joints. System design shall be such that raw edges will not be visible at joints.
- B. Frame
 - 1. Depth of frame shall not be less than 4 1/2".
 - 2. Face dimension shall not be less than 2".
 - 3. Frame components shall be screw spline construction.
- C. Glazing
 - 1. All units shall be "dry glazed" with EPDM gasket on both exterior and interior.
- D. Interior trim, closures, angles and the like shall be of sizes and shapes as shown with fastenings as required and/or specified. All snap-on design trim shall be in 0.062 inch minimum thickness. Trim shall connect to extruded aluminum anchors which shall permit the window to be anchored without

the use of fasteners thru frame which may permit air or water leakage. Trim shall be of adequate size to cover all exposed areas and to preclude painting due to installation of new materials.

- E. Exterior panning – aluminum, 0.078 inch thickness to cover all areas as noted on drawings; one piece design to abut or interlock into window frames without use of exposed fasteners; weathertight connection to allow for expansion and contraction.
- F. Set trim in full bed of sealant and seal all corners of panning trim from inside or with clear silicone ribbon from exterior. Leave installation in a clean, neat condition.
- G. Frame Finish
 - 1. Organic
 - a. Finish all exposed areas of aluminum doors and components with AA-M12-C42-R1X, 70% PVDF Ultrapon meeting AAMA 2605.
 - b. Color shall be as selected by Architect from manufacturer's standard colors.

PART 3 - EXECUTION

3.01 INSPECTION

- A. Job Conditions
 - 1. All openings shall be prepared by others to the proper size and shall be plumb, level and in the proper location and alignment as shown on the architect's drawings.
 - 2. NOTE: This non-thermal storefront system is to be used at all interior areas and interior areas of vestibules.

3.02 INSTALLATION

- A. Strictly comply with manufacturer's instructions and recommendations. Match profiles, sizes and spacings indicated on approved shop drawings. Do not perform structural silicone sealant work when the metal temperature is below 32 degrees F.
- B. Storefront system shall be erected plumb and true, in proper alignment and relation to established lines and grades.
- C. Entrance doors shall be securely anchored in place to a straight, plumb and level condition, without distortion. Weather stripping contact and hardware movement shall be checked and final adjustments made for proper operation and performance of units.
- D. Furnish and apply sealing materials to provide a weather tight installation at all joints and intersections and at opening perimeters.
- E. Sealing materials specified shall be used in strict accordance with the manufacturer's printed instructions, and shall be applied only by mechanics specially trained or experienced in their use. All surfaces must be clean and free of foreign matter before applying sealing materials. Sealing compounds shall be tooled to fill the joint and provide a smooth finished surface.
- F. Coordinate installation with adjacent work to ensure creation of a complete weatherproof assembly. Anchor work securely to supporting structure, but allow for differential and thermal movement.

- G. Isolate between aluminum and dissimilar metals with a protective coating or plastic strip to prevent electrolytic corrosion.

3.03 ANCHORAGE

- A. Adequately anchor to maintain positions permanently when subjected to normal thermal movement, specified building movement, and specified wind loads.
- B. Provide fasteners as recommended by the manufacturer for the type of substrate the window system is to be anchored.

3.04 CLEANING AND PROTECTION

- A. During installation, remove labels, part number markings, sealant smears, handprints, and construction dirt from all components.
- B. Touch-up damaged coatings and finishes and repair minor damage to eliminate all evidence of repair. Remove and replace work which cannot be satisfactorily repaired.
- C. Clean all exposed surfaces including metal and glass using non-abrasive materials and methods recommended by manufacturer of material or product being cleaned. Remove and replace work that cannot be successfully cleaned.
- D. The general contractor shall protect the aluminum materials and finish against damage from construction activities and harmful substances.

END OF SECTION

SECTION 08 54 13

FIBERGLASS WINDOWS

PART 1 GENERAL

1.1 SECTION INCLUDES

- A. Fiberglass fixed windows.

1.2 RELATED SECTIONS

- B. Section 07 92 13 - Joint Sealants: Sealants and caulking.

1.3 REFERENCES

- A. American Architectural Manufacturers Association (AAMA):
 - 1. AAMA 502 - Voluntary Specification for Field Testing of Windows and Sliding Doors.
 - 2. AAMA 624-10 - Voluntary Performance Requirements and Test Procedures for Organic Coatings on Fiber Reinforced Thermoset Profiles.
- B. American Society for Testing and Materials (ASTM):
 - 1. ASTM C 1036 - Flat Glass.
 - 2. ASTM C 1048 - Heat-Treated Flat Glass--Kind HS, Kind FT Coated and Uncoated Glass.
 - 3. ASTM E 283 - Rate of Air Leakage Through Exterior Windows, Curtain Walls and Doors Under Specified Pressure Difference Across the Specimen.
 - 4. ASTM E 330 – Standard Test Method for Structural Performance of Exterior Windows, Doors, Skylights and Curtain Walls by Uniform Static Air Pressure Difference.
 - 5. ASTM E 547 - Water Penetration of Exterior Windows, Curtain Walls and Doors by Cyclic Static Air Pressure Differential.
 - 6. ASTM E 1105 – Standard Test Method for Field Determination of Water Penetration of Exterior Windows, Doors, Skylights and Curtain Walls by Uniform Static Air Pressure Difference.
- C. Window and Door Manufacturers Association (WDMA):
 - 1. ANSI/AAMA/NWDA 101/I.S.2 - Voluntary Specifications for Aluminum, Vinyl (PVC) and Wood Windows and Glass Doors.
- D. Screen Manufacturers Association (SMA):
 - 1. SMA 1201 – Specifications for Insect Screens for Windows, Sliding Doors and Swinging Doors.
- E. Window and Door Manufacturers Association (WDMA):
 - 1. AAMA/WDMA/CSA 101/I.S.2/A440 – North American Fenestration Standard/Specification for Windows, Doors, and Skylights.

1.4 PERFORMANCE REQUIREMENTS

- A. Fixed sash & frame windows shall meet a rating of CW-50 specifications in accordance with ANSI/AAMA/WWDMA 101/I.S.2/A440-17.

- B. Window Air Leakage, ASTM E 283: Window air leakage when tested at 1.57 psf (25 mph) shall be 0.05 cfm/ft² of frame or less.
- C. Window Water Penetration, ASTM E 547: No water penetration through window when tested under static pressure of 7.5 psf (42 mph) after 4 cycles of 5 minutes each, with water being applied at a rate of 5 gallons per hour per square foot.

1.5 SUBMITTALS

- A. Submit under provisions of Section 01 33 00.
- B. Product Data: Submit manufacturer's product data, including installation instructions.
- C. Shop Drawings: Submit manufacturer's shop drawings, indicating dimensions, construction, component connections and locations, anchorage methods and locations, hardware locations, and installation details.
- D. Samples: Submit manufacturer's samples for selection of color finish.

1.6 QUALITY ASSURANCE

- A. Mockup:
 - 1. Provide sample installation for field testing window performance requirements and to determine acceptability of window installation methods.
 - 2. Approved mockup shall represent minimum quality required for the Work.
 - 3. Approved mockup shall remain in place within the Work.

1.7 DELIVERY, STORAGE, AND HANDLING

- A. Deliver, store, protect and handle products to site under provisions of Section 01 60 00.
- B. Delivery: Deliver materials to site undamaged in manufacturer's or sales branch's original, unopened containers and packaging, with labels clearly identifying manufacturer and product name. Include installation instructions.
- C. Storage:
 - 1. Store materials in accordance with manufacturer's instructions.
 - 2. Store materials off ground and under cover.
 - 3. Protect materials from weather, direct sunlight, and construction activities.
- D. Handling: Protect materials and finish during handling and installation to prevent damage.

PART 2 PRODUCTS

2.1 MANUFACTURER

- A. Pella Corporation, 102 Main Street, Pella, Iowa 50219.
Toll Free (800) 54-PELLA. Phone (641) 621-1000. Website www.pella.com.
- B. Substitutions: Under provisions of Section 01 60 00.

2.2 FIBERGLASS WINDOWS

- A. Windows: Pella Impervia.
 - 1. Factory-assembled fiberglass fixed sash and frame units.
 - 2. Frame and Sash Material: 5-layer, pultruded-fiberglass material, reinforced with interlocking mat.
- B. Frame:
 - 1. Type: Integral Nail Fin.
 - 2. Interior and Exterior Frame: Pultruded, fiberglass composite with foam inserts.
 - 3. Overall Frame Depth: 3-1/4 inches.
 - 4. Nominal Wall Thickness of Fiberglass Members: 0.050 inch to 0.090 inch.
 - 5. Frame Corners:
 - a. Mitered.
 - b. Joined and bonded with Neutral-cure Room Temperature Vulcanizing silicone hot-melt adhesive, with corner lock.
 - 6. Jambs: Contain factory-drilled installation screw holes.
- C. Sash:
 - 1. Sash Corners:
 - a. Mitered.
 - b. Bonded and sealed with injected Neutral-cure Room Temperature Vulcanizing silicone hot-melt adhesive.
- D. Glazing:
 - 1. Float Glass: ASTM C 1036, Quality 1.
 - a. Tempered Glass: ASTM C 1048 where required by the RI Building Code.
 - 2. Type: Polyurethane reactive (PUR) hot-melt glazed, 1-inch thick triple-pane, insulating glass, multi-layer Low-E coated with argon.

2.3 TOLERANCES

- A. Windows shall accommodate the following opening tolerances:
 - 1. Vertical Dimensions Between High and Low Points: Plus 1/4-inch, minus 0 inch.
 - 2. Width Dimensions: Plus 1/4-inch, minus 0 inch.
 - 3. Building Columns or Masonry Openings: Plus or minus 1/4-inch from plumb.

2.4 FINISH

- A. Exterior and Interior Finish: Factory-applied powder-coat paint, comply with AAMA 624-10.
 - 1. The colors are to be selected by the Architect from the manufacturer's standard colors.

2.5 INSTALLATION ACCESSORIES

- A. Flashing/Sealant Tape: Pella SmartFlash.
 - 1. Aluminum-foil-backed butyl window and door flashing tape.
 - 2. Maximum Total Thickness: 0.013 inch.
 - 3. UV resistant.
 - 4. Verify sealant compatibility with sealant manufacturer.

- B. Interior Insulating-Foam Sealant: Low-expansion, low-pressure polyurethane insulating window and door foam sealant.
- C. Exterior Perimeter Sealant: “Pella Window and Door Installation Sealant” or equivalent high quality, multi-purpose sealant as specified in the joints sealant section.
- D. Block Frame Installation Accessories: Vinyl installation fin.

PART 3 EXECUTION

3.1 EXAMINATION

- A. Examine areas to receive windows. Notify Architect of conditions that would adversely affect installation or subsequent use. Do not proceed with installation until unsatisfactory conditions are corrected.

3.2 INSTALLATION

- A. Install windows in accordance with manufacturer's instructions.
- B. Install windows to be weather-tight.
- C. Maintain alignment with adjacent work.
- D. Secure assembly to framed openings, plumb and square, without distortion.
- E. Integrate window system installation with exterior water-resistant barrier using flashing/sealant tape. Apply and integrate flashing/sealant tape with water-resistant barrier using watershed principles in accordance with window manufacturer's instructions.
- F. Place interior seal around window perimeter to maintain continuity of building thermal and air barrier using insulating foam sealant.
- G. Seal window to exterior wall cladding with sealant and related backing materials at perimeter of assembly.

3.3 FIELD QUALITY CONTROL

- A. Manufacturer’s Field Services: Upon Owner’s request, provide manufacturer’s field service consisting of product use recommendations and periodic site visit for inspection of product installation in accordance with manufacturer’s instructions.

3.4 FIELD QUALITY CONTROL TESTING

- A. Testing Agency: Engage a qualified testing agency to perform field tests and inspections and prepare test reports.
 - 1. Testing and inspecting agency will interpret tests and state in each report whether tested work complies with or deviates from requirements.
- B. Testing Services: Testing and inspecting of installed storefront shall take place as follows:

1. Testing Methodology: Testing Standard shall be per AAMA 502: *Voluntary Specification for Field Testing of Newly Installed Fenestration Products* including reference to ASTM E 1105 for Water Penetration Test.
 - a. Water Infiltration Test: Water penetration resistance tests shall be conducted in accordance with ASTM E 1105 at a static test pressure equal to 2/3 the specified water test pressure. No water penetration shall occur as defined in AAMA 502.
2. Testing Extent: A maximum of 10 percent of all installed storefront is to be tested. The Architect shall select window units to be tested as soon as a representative portion of the project has been installed, glazed, perimeter caulked and cured. Conduct tests for water penetration with representatives from the manufacturer, Contractor and Owner or Architect present.
3. Test Reports: Shall be prepared according to AAMA 502.

3.5 CLEANING

- A. Clean window frames and glass in accordance with Division 1 requirements.
- B. Do not use harsh cleaning materials or methods that would damage finish or glass.
- C. Remove labels and visible markings.

3.6 PROTECTION

- A. Protect installed windows to ensure that, except for normal weathering, windows will be without damage or deterioration at time of substantial completion.

END OF SECTION

THIS PAGE INTENTIONALLY LEFT BLANK

SECTION 08 71 00

DOOR HARDWARE

PART 1 - GENERAL

1.1 RELATED DOCUMENTS

- A. Drawings and general provisions of the Contract, including General Conditions and Division 1 Specification Sections, apply to this Section.

1.2 SUMMARY

- A. This Section includes commercial door hardware for the following:
 - 1. Swinging doors.
 - 2. Other doors to the extent indicated.
- B. Door hardware includes, but is not necessarily limited to, the following:
 - 1. Mechanical door hardware.
 - 2. Cylinders specified for doors in other sections.
 - 3. Electromechanical door hardware, power supplies, back-ups and surge protection.
- C. Related Sections:
 - 1. Section 08 12 13 - Steel Door Frames
 - 2. Section 08 13 13 - Steel Doors
 - 3. Section 08 14 16 – Wood Doors
 - 4. Section 08 42 13 – Aluminum Entrance doors
 - 5. Section 08 43 13 – Aluminum Storefront System
- D. Codes and References: Comply with the version year adopted by the Authority Having Jurisdiction.
 - 1. ANSI A117.1 - Accessible and Usable Buildings and Facilities.
 - 2. ICC/IBC - International Building Code.
 - 3. NFPA 70 - National Electrical Code.
 - 4. NFPA 80 - Fire Doors and Windows.
 - 5. NFPA 101 - Life Safety Code.
 - 6. NFPA 105 - Installation of Smoke Door Assemblies.
 - 7. State Building Codes, Local Amendments.
- E. Standards: All hardware specified herein shall comply with the following industry standards:
 - 1. ANSI/BHMA Certified Product Standards - A156 Series
 - 2. UL10C – Positive Pressure Fire Tests of Door Assemblies

1.3 SUBMITTALS

- A. Product Data: Manufacturer's product data sheets including installation details, material descriptions, dimensions of individual components and profiles, operational descriptions and finishes. Submit under provisions of Section 01 33 00.
- B. Door Hardware Schedule: Prepared by or under the supervision of supplier, detailing fabrication and assembly of door hardware, as well as procedures and diagrams. Coordinate the final Door Hardware Schedule with doors, frames, and related work to ensure proper size, thickness, hand, function, and finish of door hardware.
 - 1. Format: Comply with scheduling sequence and vertical format in DHI's "Sequence and Format for the Hardware Schedule."
 - 2. Organization: Organize the Door Hardware Schedule into door hardware sets indicating complete designations of every item required for each door or opening. Organize door hardware sets in same order as in the Door Hardware Sets at the end of Part 3. Submittals that do not follow the same format and order as the Door Hardware Sets will be rejected and subject to resubmission.
 - 3. Content: Include the following information:
 - a. Type, style, function, size, label, hand, and finish of each door hardware item.
 - b. Manufacturer of each item.
 - c. Fastenings and other pertinent information.
 - d. Location of door hardware set, cross-referenced to Drawings, both on floor plans and in door and frame schedule.
 - e. Explanation of abbreviations, symbols, and codes contained in schedule.
 - f. Mounting locations for door hardware.
 - g. Door and frame sizes and materials.
 - 4. Submittal Sequence: Submit the final Door Hardware Schedule at earliest possible date, particularly where approval of the Door Hardware Schedule must precede fabrication of other work that is critical in the Project construction schedule. Include Product Data, Samples, Shop Drawings of other work affected by door hardware, and other information essential to the coordinated review of the Door Hardware Schedule.
- C. Operating and Maintenance Manuals: Provide manufacturer's operating and maintenance manuals for each item comprising the complete door hardware installation in quantity as required in Division 01, Closeout Submittals. The manual to include the name, address, and contact information of the manufacturers providing the hardware and their nearest service representatives. The final copies delivered after completion of the installation test to include "as built" modifications made during installation, checkout, and acceptance.
- D. Warranties and Maintenance: Special warranties specified in this Section.

1.4 QUALITY ASSURANCE

- A. Manufacturers Qualifications: Engage qualified manufacturers with a minimum 5 years of documented experience in producing hardware and equipment similar to that indicated for this Project and that have a proven record of successful in-service performance.
- B. Installer Qualifications: Installers, trained by the primary product manufacturers, with a minimum 3 years documented experience installing both standard and electrified builders hardware similar in material,

design, and extent to that indicated for this Project and whose work has resulted in construction with a record of successful in-service performance.

- C. Door Hardware Supplier Qualifications: Experienced commercial door hardware distributors with a minimum 5 years documented experience supplying both mechanical and electromechanical hardware installations comparable in material, design, and extent to that indicated for this Project. Supplier recognized as a factory direct distributor in good standing by the manufacturers of the primary materials with a warehousing facility in Project's vicinity. Supplier to have on staff a certified Architectural Hardware Consultant (AHC) available during the course of the Work to consult with Contractor, Architect, and Owner concerning both standard and electromechanical door hardware and keying.
1. Scheduling Responsibility: Preparation of door hardware and keying schedules.
- D. Source Limitations: Obtain each type and variety of Door Hardware specified in this Section from a single source, qualified supplier unless otherwise indicated.
1. Electrified modifications or enhancements made to a source manufacturer's product line by a secondary or third party source will not be accepted.
 2. Provide electromechanical door hardware from the same manufacturer as mechanical door hardware, unless otherwise indicated.
- E. Regulatory Requirements: Comply with NFPA 70, NFPA 80, NFPA 101 and ANSI A117.1 requirements and guidelines as directed in the model building code including, but not limited to, the following:
1. NFPA 70 "National Electrical Code", including electrical components, devices, and accessories listed and labeled as defined in Article 100 by a testing agency acceptable to authorities having jurisdiction, and marked for intended use.
 2. Where indicated to comply with accessibility requirements, comply with the State Building Code and the Americans with Disabilities Act (ADA), "Accessibility Guidelines for Buildings and Facilities (ADAAG)," ANSI A117.1 as follows:
 - a. Handles, Pulls, Latches, Locks, and other Operating Devices: Shape that is easy to grasp with one hand and does not require tight grasping, tight pinching, or twisting of the wrist.
 - b. Door Closers: Comply with the following maximum opening-force requirements indicated:
 - 1) Interior Hinged Doors: 5 lbf applied perpendicular to door.
 - 2) Fire Doors: Minimum opening force allowable by authorities having jurisdiction.
 - c. Thresholds: Not more than 1/2 inch high. Bevel raised thresholds with a slope of not more than 1:2.
 3. NFPA 101: Comply with the following for means of egress doors:
 - a. Latches, Locks, and Exit Devices: Not more than 15 lbf to release the latch. Locks shall not require the use of a key, tool, or special knowledge for operation.
 - b. Thresholds: Not more than 1/2 inch high.
 4. Fire-Rated Door Assemblies: Provide door hardware for assemblies complying with NFPA 80 that are listed and labeled by a testing and inspecting agency acceptable to authorities having

jurisdiction, for fire ratings indicated, based on testing according to NFPA 252 (neutral pressure at 40" above sill) or UL-10C.

a. Test Pressure: Positive pressure labeling.

- F. Each unit to bear third party permanent label demonstrating compliance with the referenced standards.
- G. Keying Conference: Conduct conference to comply with requirements in Division 01 Section "Project Meetings." Keying conference to incorporate the following criteria into the final keying schedule document:
1. Function of building, purpose of each area and degree of security required.
 2. Plans for existing and future key system expansion.
 3. Requirements for key control storage and software.
 4. Installation of permanent keys, cylinder cores and software.
 5. Address and requirements for delivery of keys.
- H. Pre-Submittal Conference: Conduct coordination conference in compliance with requirements in Division 01 Section "Project Meetings" with attendance by representatives of Supplier(s), Installer(s), and Contractor(s) to review proper methods and the procedures for receiving, handling, and installing door hardware.
1. Prior to installation of door hardware, arrange for manufacturers' representatives to hold a project specific training meeting to instruct the installing contractors' personnel on the proper installation and adjustment of their respective products. Product training to be attended by installers of door hardware (including electromechanical hardware) for aluminum, hollow metal and wood doors. Training will include the use of installation manuals, hardware schedules, templates and physical product samples as required.
 2. Inspect and discuss electrical roughing-in, power supply connections, and other preparatory work performed by other trades.
 3. Review sequence of operation narratives for each unique access controlled opening.
 4. Review and finalize construction schedule and verify availability of materials.
 5. Review the required inspecting, testing, commissioning, and demonstration procedures.

1.5 DELIVERY, STORAGE, AND HANDLING

- A. Deliver, store, protect and handle products to site under provisions of Section 01 60 00.
- B. Inventory door hardware on receipt and provide secure lock-up and shelving for door hardware delivered to Project site. Do not store electronic access control hardware, software or accessories at Project site without prior authorization.
- C. Tag each item or package separately with identification related to the final Door Hardware Schedule, and include basic installation instructions with each item or package.
- D. Deliver, as applicable, permanent keys, cylinders, cores, access control credentials, software and related accessories directly to Owner via registered mail or overnight package service. Instructions for delivery to the Owner shall be established at the "Keying Conference".

1.6 COORDINATION

- A. Templates: Obtain and distribute to the parties involved templates for doors, frames, and other work specified to be factory prepared for installing standard and electrified hardware. Check Shop Drawings of other work to confirm that adequate provisions are made for locating and installing hardware to comply with indicated requirements.
- B. Door Hardware and Electrical Connections: Coordinate the layout and installation of scheduled electrified door hardware and related access control equipment with required connections to source power junction boxes, low voltage power supplies, detection and monitoring hardware, and fire and detection alarm systems.
- C. Field verify all dimensions and locations prior to shop drawing submittal.

1.7 WARRANTY

- A. General Warranty: Reference Division 01, General Requirements. Special warranties specified in this Article shall not deprive Owner of other rights Owner may have under other provisions of the Contract Documents and shall be in addition to, and run concurrent with, other warranties made by Contractor under requirements of the Contract Documents.
- B. Warranty Period: Written warranty, executed by manufacturers, agreeing to repair or replace components of standard and electrified door hardware that fails in materials or workmanship within specified warranty period after final acceptance by the Owner, this includes all labor required to repair or replace product. Failures include, but are not limited to, the following:
 - 1. Structural failures including excessive deflection, cracking, or breakage.
 - 2. Faulty operation of the hardware.
 - 3. Deterioration of metals, metal finishes, and other materials beyond normal weathering.
 - 4. Electrical component defects and failures within the systems operation.
- C. Standard Warranty Period: One year from date of Substantial Completion, unless otherwise indicated.
- D. Special Warranty Periods:
 - 1. Ten years for extra heavy duty cylindrical (bored) locks and latches.
 - 2. Seven years for heavy duty cylindrical (bored) locks and latches.
 - 3. Five years for exit hardware.
 - 4. Ten years for manual door closers.
 - 5. Two years for electromechanical door hardware.

1.8 MAINTENANCE

- A. Maintenance Tools and Instructions: Provide a complete set of specialized tools and maintenance instructions for Owner's continued adjustment, maintenance, removal and replacement of door hardware.

PART 2 - PRODUCTS

2.1 SCHEDULED DOOR HARDWARE

- A. General: Provide door hardware for each door to comply with requirements in Door Hardware Sets and each referenced section that products are to be supplied under.
1. Designations: Requirements for quantity, item, size, finish or color, grade, function, and other distinctive qualities of each type of door hardware are indicated in the Door Hardware Sets at the end of Part 3.
 - a. Named Manufacturer's Products: Product designation and manufacturer are listed for each door hardware type required for the purpose of establishing requirements.
The hardware schedule is based on the following manufacturers:
 1. Locks, passage & privacy sets-Sargent
 2. Exit devices - Sargent
 3. Continuous hinge - Roton by Hager Hinge Co.
- B. Substitutions: Requests for substitution and product approval for inclusive mechanical and electromechanical door hardware in compliance with the specifications must be submitted in writing and in accordance with the procedures and time frames outlined in AIA Document A701 – Instructions To Bidders and Division 01, Section 01 60 00, Substitution Procedures. Approval of requests is at the discretion of the architect, owner, and their designated consultants.

2.2 HANGING DEVICES

- A. Hinges: ANSI/BHMA A156.1 certified butt hinges, full mortise unless otherwise indicated.
1. Quantity: Provide the following hinge quantity, unless otherwise indicated:
 - a. Two Hinges: For doors with heights up to 60 inches.
 - b. Three Hinges: For doors with heights 61 to 90 inches.
 - c. Four Hinges: For doors with heights 91 to 120 inches.
 - d. For doors with heights more than 120 inches, provide 4 hinges, plus 1 hinge for every 30 inches of door height greater than 120 inches.
 2. Hinge Size: Provide the following, unless otherwise indicated, with hinge widths sized for door thickness and clearances required:
 - a. Widths up to 3'-0": provide 4-1/2" x 4-1/2" standard hinges!
 - b. NOTE: 42" door widths are to use continuous geared hinges even if the hardware schedule at the end of Part 3 lists the hinge as "butts".
 3. Hinge Weight and Base Material: Unless otherwise indicated, provide the following:
 - a. Exterior Doors: Provide continuous gear hinges.
 - b. Interior Doors: Standard weight, steel, 5 knuckle, ball bearing hinges unless Hardware Sets indicate heavy weight.

4. Hinge Options: Comply with the following where indicated in the Hardware Sets or on Drawings:
- a. Non-removable Pins: Provide set screw in hinge barrel that, when tightened into a groove in hinge pin, prevents removal of pin while door is closed; for the following applications:
 - 1) Doors out-swinging into corridors.
 - 2) Exterior doors

5. Acceptable Manufacturers:
- a. Bommer Industries (BO).
 - b. Hager Companies (HA).
 - c. Ives (IV).
 - d. McKinney Products (MK).
 - e. Stanley Hardware (ST).

B. Continuous Geared Hinges: ANSI/BHMA A156.26 certified continuous geared hinge with minimum 0.120-inch thick extruded 6060 T6 aluminum alloy hinge leaves and a minimum overall width of 4 inches. Hinges are non-handed, reversible and fabricated to template screw locations. Provide concealed flush mount (with or without inset), full surface, or half surface, in standard and heavy duty models, as specified in the Hardware Sets. Concealed continuous hinges to be U.L. listed for use on up to and including 90 minute rated door installations and U.L. listed for windstorm components where applicable. Factory cut hinges for door size.

1. Acceptable Manufacturers:
- a. Roton by Hager Hinge Co. (RO)
 - b. Bommer Industries (BO).
 - c. Ives (IV).
 - d. McKinney Products (MK).
 - e. Pemko Manufacturing (PE).
 - f. Stanley Hardware (ST).
 - g. Select Hinges (SH)

2.3 DOOR OPERATING TRIM

A. Flush Bolts: ANSI/BHMA A156.3 and A156.16, Grade 1, certified automatic, self-latching, and manual flush bolts. Manual flush bolts to be furnished with top rod of sufficient length to allow bolt location approximately six feet from the floor. Provide dust-proof strikes for all bottom bolts. Surface bolts to be minimum 8" in length and U.L. listed for labeled fire doors and U.L. listed for windstorm components where applicable. Provide related accessories (mounting brackets, strikes, door to door thermal pins, coordinators, etc.) as required for appropriate installation and operation.

1. Acceptable Manufacturers:
- a. Burns Manufacturing (BU).
 - b. Door Controls International (DC).
 - c. Ives (IV).
 - d. Rockwood Manufacturing (RO).

- e. Trimco (TC).
- B. Coordinators: ANSI/BHMA A156.3 certified door coordinators consisting of active-leaf, hold-open lever and inactive-leaf release trigger. Coordinators fabricated from steel with nylon-coated strike plates and built-in adjustable safety release.
1. Acceptable Manufacturers:
 - a. Burns Manufacturing (BU).
 - b. Door Controls International (DC).
 - c. Ives (IV).
 - d. Rockwood Manufacturing (RO).
 - e. Trimco (TC).
- C. Door Push Plates and Pulls: ANS/BHMA A156.6 certified door pushes and pulls of type and design specified below or in the Hardware Sets. Coordinate and provide proper width and height as required where conflicting hardware dictates.
1. Push/Pull Plates: Minimum .050 inch thick, 4-inches wide by 16-inches high, stainless steel with square corners and beveled edges, secured with exposed screws unless otherwise indicated.
 2. Straight Pull Design: Minimum 1-inch round diameter stainless steel tube stock pulls with 2 1/2-inch clearance from face of door. Length to be 10" center to center. Attach with concealed fasteners as required for door type. All pulls will include an associated plate.
 3. Fasteners: Provide manufacturer's designated fastener type as indicated in Hardware Sets. All fasteners used for attachment are to be of anti-theft design.
 4. Acceptable Manufacturers:
 - a. Burns Manufacturing (BU).
 - b. Hiawatha, Inc. (HI).
 - c. Ives (IV).
 - d. Rockwood Manufacturing (RO).
 - e. Trimco (TC).
 - f. Hager Companies (HA).
- D. Kickplates shall be 10" high x 2" less than nominal door width (unless noted otherwise in the hardware schedule), .050" thick stainless steel with 4 beveled edges.. Install on push side of door. All fasteners used for attachment are to be of anti-theft design.
1. Acceptable Manufacturers:
 - a. Burns Manufacturing (BU).
 - b. Hiawatha, Inc. (HI).
 - c. Ives (IV).
 - d. Rockwood Manufacturing (RO).
 - e. Trimco (TC).
 - f. Hager Companies (HA).

2.4 CYLINDERS AND KEYING

- A. Locks shall be grandmaster keyed as directed by the Owner and Architect.

- B. Supply two keys for each lock and 5 master keys for each master key grouping.
- C. Provide all keys of nickel silvermetal only.
- D. Hardware consultant shall meet with owner/architect to determine specific keying requirements and functions of locks.
- E. Cylinders to be high security interchangeable core 6-pin.

2.5 MECHANICAL LOCKS AND LATCHING DEVICES

- A. Cylindrical Locksets, Grade 1 (Heavy Duty): ANSI/BHMA A156.2, Series 4000, Grade 1 certified cylindrical (bored) locksets **and be tested by an independent third party testing agency to meet a minimum of 10 million cycle tests** furnished in the functions as specified in the Hardware Sets. Lock chassis fabricated of heavy gauge steel, zinc dichromate plated, with through-bolted application. Furnish with solid cast levers, standard 2 3/4" backset, and 1/2" (3/4" at rated paired openings) throw brass or stainless steel latchbolt. Locks are to be non-handed and fully field reversible.
 - 1. Locksets to incorporate a free-wheeling lever design with a lifetime warranty against lever sag and spring breakage on all locking functions.
 - 2. Acceptable Manufacturers:
 - a. Corbin Russwin Hardware (RU) – CL3300 Series.
 - b. Sargent Manufacturing (SA) – 10 Line.
 - c. Schlage (SC) – ND Series.
 - 3. Lever shall be "L" and L Rose or equal from acceptable manufacturers.
 - 4. Cylinders: Sargent high security interchangeable core 6-pin or equal.
 - 5. Tactile warning - Levers shall be KNURLED or MILLED at doors leading into all hazardous locations (ie. electric rooms, mechanical rooms, elevator machine rooms). Do not use abrasive coating or applied tape in lieu of knurling or milling.
- B. Mortise Locksets, Grade 1 (Heavy Duty): ANSI/BHMA A156.13, Series 1000, Security Grade 1 certified mortise locksets **and be tested by an independent third party testing agency to meet a minimum of 10 million cycle tests** furnished in the functions as specified in the Hardware Sets. Lock chassis fabricated of heavy gauge steel, zinc dichromate plated, with through-bolted application. Furnish with solid cast levers, standard 2 3/4" backset, and 3/4" throw anti-friction stainless steel latch. Deadbolts, where specified, are to be full 1" throw made of one-piece hardened stainless steel. Locks are to be non-handed and fully field reversible.
 - 1. Locksets to incorporate a free-wheeling lever design with a lifetime warranty against lever sag and spring breakage on all locking functions.
 - 2. Acceptable Manufacturers:
 - a. Corbin Russwin Hardware (RU) – ML2000 Series.

- b. Sargent Manufacturing (SA) – 8200 Series.
 - c. Schlage (SC) – L9000 Series.
3. Sargent 8200 series with "L" levers and 2" Dia. "LN" rosettes or equal subject to provisions of Section 01 60 00.
 4. Tactile warning - Levers shall be KNURLED or MILLED at doors leading into all hazardous locations (ie. electric rooms, mechanical rooms, elevator machine rooms, hazardous storage rooms, etc.). Do not use abrasive coating or applied tape in lieu of knurling or milling.

2.6 CONVENTIONAL EXIT DEVICES

A. General Requirements: All exit devices specified herein shall meet or exceed the following criteria:

1. At doors not requiring a fire rating, provide devices complying with NFPA 101 and listed and labeled for "Panic Hardware" according to UL305. Provide proper fasteners as required by manufacturer including sex nuts and bolts at openings specified in the Hardware Sets.
 2. Where exit devices are required on fire rated doors, provide devices complying with NFPA 80 and with UL labeling indicating "Fire Exit Hardware". Provide devices with the proper fasteners for installation as tested and listed by UL. Consult manufacturer's catalog and template book for specific requirements.
 3. Except on fire rated doors, provide exit devices with keyed cylinder dogging to hold the pushbar and latch in a retracted position.
 4. Flush End Caps: Provide heavy weight impact resistant flush end caps made of architectural metal in the same finish as the devices as in the Hardware Sets. Plastic end caps will not be acceptable.
 5. Lever Operating Trim: Where exit devices require lever trim, furnish manufacturer's heavy duty trim with cold forged escutcheons, beveled edges, and four threaded studs for thru-bolts.
 - a. Lock Trim Design: As indicated in Hardware Sets, provide design to match that of the specified locksets. Provided free-wheeling type trim.
 - b. Where function of exit device requires a cylinder, provide an interchangeable core type keyed cylinder (Rim or Mortise) as specified.
 6. Narrow Stile Applications: At doors constructed with narrow stiles, or as specified in Hardware Sets, provide devices designed for maximum 2" wide stiles.
 7. Rail Sizing: Provide exit device rails factory sized for proper door width application.
 8. Through Bolt Installation: For exit devices and trim as indicated in Door Hardware Sets.
 9. Lever handle design shall be Sargent type "L" or equal.
- B. Conventional Push Rail Exit Devices (Heavy Duty): ANSI/BHMA A156.3, Grade 1 certified panic and fire exit hardware devices furnished in the functions specified in the Hardware Sets **and be tested by an**

independent third party testing agency to meet a minimum of 10 million cycle tests. Mounting rails to be formed from smooth stainless steel, brass or bronze architectural materials no less than 0.072" thick, with push rails a minimum of 0.062" thickness. Painted or aluminum metal rails are not acceptable. Exit device latch to be investment cast stainless steel, pullman type, with deadlock feature.

1. Acceptable Manufacturers:
 - a. Corbin Russwin Hardware (RU) - ED4000 / ED5000 Series.
 - b. Sargent Manufacturing (SA) - 80 Series.
 - c. Von Duprin (VD) - 35A/98/99 XP Series.
 - d. Precision Apex 2000 Series.

2.7 DOOR CLOSERS

A. All door closers specified herein shall meet or exceed the following criteria:

1. General: Door closers to be from one manufacturer, matching in design and style, with the same type door preparations and templates regardless of application or spring size. Closers to be non-handed with full sized covers including installation and adjusting information on inside of cover.
2. Standards: Closers to comply with UL-10C and UBC 7-2 for Positive Pressure Fire Test and be U.L. listed for use of fire rated doors.
3. Size of Units: Comply with manufacturer's written recommendations for sizing of door closers depending on size of door, exposure to weather, and anticipated frequency of use. Where closers are indicated for doors required to be accessible to the physically handicapped, provide units complying with ANSI ICC/A117.1.
4. Closer Arms: Provide heavy duty, forged steel closer arms unless otherwise indicated in Hardware Sets.
 - a. Where closers are indicated to have mechanical hold open, provide heavy duty units with an additional built-in mechanical holder assembly designed to hold open against normal wind and traffic conditions. Holder to be manually selectable to on-off position.
 - b. Where closers are indicated to have a cushion-type stop, provide heavy duty arms and brackets with spring stop mechanism to cushion door when opened to maximum degree.
 - c. Closers shall not be installed on exterior or corridor side of doors; where possible, install the closers on door for optimum aesthetics. Provide drop plates or other accessories as required for proper mounting.
5. Closer Accessories: Provide door closer accessories including custom templates, special mounting brackets, spacers and drop plates as required for a complete installation.

B. Door Closers, Surface Mounted (Heavy Duty): ANSI/BHMA A156.4, Grade 1 surface mounted, heavy duty door closers **and be tested by an independent third party testing agency to meet a minimum of 5 million cycle tests**, with complete spring power adjustment, sizes 1 thru 6; and fully operational adjustable according to door size, frequency of use, and opening force. Closers to be rack and pinion type, one piece cast iron or aluminum alloy body construction, with adjustable backcheck and separate non-critical valves for closing sweep and latch speed control. Provide non-handed units and high impact, non-corrosive plastic covers standard.

1. Acceptable Manufacturers:
 - a. Corbin Russwin Hardware (RU) – DC8000 Series.
 - b. LCN Closers (LC) - 4040XP Series.
 - c. Sargent Manufacturing (SA) - 351 Series.
 - d. Norton Door Controls (NO) - 7500 Series.

2.8 DOOR STOPS

- A. General: Door stops to be of type and design as specified below or in the Hardware Sets.
- B. Door Stops and bumpers: ANSI/BHMA A156.16, Grade 1 certified door stops and wall bumpers. Provide wall bumpers, concave types with anchorage as indicated, unless floor or other types of door stops are specified in Hardware Sets. Do not mount floor stops where they will impede traffic.

1. Acceptable Manufacturers:
 - a. Ives (IV).
 - b. Rockwood Manufacturing (RO).
 - c. Trimco (TC).

2.9 DOOR SILENCERS

- A. All new interior metal door frames shall be provided with door silencers, 3 per single door and 2 for pair of doors.

2.10 ELECTROMAGNETIC LOCK SYSTEM

- A. General: Electromagnetic locks are to incorporate the items specified below as required to install a complete operating electromagnetic locking system.
 1. Electromagnetic Lock – minimum 1,000 lbs holding force, provide plate and brackets as required.
 - a. Acceptable manufacturers:
 1. Schlage M-450
 2. Securitron M62
 3. Hager 2942
 1. One Power Supply - Schlage PS 904 (or equal) 4 amp with Emergency Interface/Fire Alarm Relay connected to fire alarm system. Provide all wiring to electromagnetic lock, proximity reader access control, and power as required for entire system to operate properly.
 2. One interior mounted Key Switch – Schlage 653-14 – L2-SF-626 (or equal) maintained on/off switch with red/green LEDs.
Provide cylinder and keyway coordinated with associated building’s hardware keyway system.
 3. Unlocking of the electromagnetic lock will be by proximity reader access control. Magnetic lock is to be a Fail-Safe device that is in lock mode unless unlocked by one of the methods listed above, by the fire alarm, by a power outage or by the on/off key switch.
 4. Note: General contractor must ensure the low voltage wiring associated with the electromagnetic lock system is installed to and in coordination with the remainder of building wiring and connected to the fire alarm system. Provide all electrical connections between building electrical and door

equipment as required for a fully operational device. Contractor must also insure 120 VAC power is installed to electrify the power supply device. Provide wiremold, etc. as required for a complete installation.

2.11 POWER SUPPLY

- A. Power supply for electronic access control and security components.
- B. Provide and install all electrical connections, wiring, junction boxes, etc. as required between building electrical and power supply unit to make fully operational. Provide all components necessary to connect to access control system readers.
- C. Basis of design is Boxed Power Supply by Securitron/Assa Abloy, model BPS-24-1

2.12 DOOR WIRING HARNESS AND HINGE

- A. Cabling/harnesses to be as follows:
 - 1. Door Wiring Harness - Cable between hinge and through the door to the lockset or exit device:
ElectroLynx QC-C206
 - 2. Frame Wiring Harness - Cable from the hinge location, up the jamb to above ceiling:
ElectroLynx QC-C1500P

2.13 ACCESSORIES

- A. Key Cabinet: Provide a key cabinet manufactured of 18 ga. cold rolled steel with a capacity for 50% more keys than required for the project. Provide a two tag system with all cross indexing materials. Lund DeLuxe or equal.
 - 1. All project keys are to be tagged, numbered and hung in the key cabinet for delivery to Owner.
 - 2. Verify location with Architect.

2.14 FABRICATION

- A. Fasteners: Provide door hardware manufactured to comply with published templates generally prepared for machine, wood, and sheet metal screws. Provide screws according to manufacturers recognized installation standards for application intended.

2.15 FINISHES

- A. Standard: Designations used in the Hardware Sets and elsewhere indicate hardware finishes complying with ANSI/BHMA A156.18, including coordination with traditional U.S. finishes indicated by certain manufacturers for their products.
- B. Provide quality of finish, including thickness of plating or coating (if any), composition, hardness, and other qualities complying with manufacturer's standards, but in no case less than specified by referenced standards for the applicable units of hardware.

- C. Protect mechanical finishes on exposed surfaces from damage by applying a strippable, temporary protective covering before shipping.
- D. Hardware in General: US26D Dull Chrome
- E. Exit Devices, flat goods - US32D - Satin Stainless Steel
- F. Continuous hinges - clear anodized aluminum or dark bronze anodized (selected by Architect)s

PART 3 - EXECUTION

3.1 EXAMINATION

- A. Examine scheduled openings, with Installer present, for compliance with requirements for installation tolerances, labeled fire door assembly construction, wall and floor construction, and other conditions affecting performance.
- B. Notify architect of any discrepancies or conflicts between the door schedule, door types, drawings and scheduled hardware. Proceed only after such discrepancies or conflicts have been resolved in writing.

3.2 PREPARATION

- A. Hollow Metal Doors and Frames: Comply with ANSI/DHI A115 series.

3.3 INSTALLATION

- A. Install each item of mechanical and electromechanical hardware and access control equipment to comply with manufacturer's written instructions and according to specifications.
 - 1. Installers are to be trained and certified by the manufacturer on the proper installation and adjustment of fire, life safety, and security products including: hanging devices; locking devices; closing devices; and seals.
- B. Mounting Heights: Mount door hardware units at heights indicated in following applicable publications, unless specifically indicated or required to comply with governing regulations:
 - 1. Standard Steel Doors and Frames: DHI's "Recommended Locations for Architectural Hardware for Standard Steel Doors and Frames."
 - 2. Wood Doors: DHI WDHS.3, "Recommended Locations for Architectural Hardware for Wood Flush Doors."
 - 3. Where indicated to comply with accessibility requirements, comply with ANSI A117.1 "Accessibility Guidelines for Buildings and Facilities."
 - 4. Provide blocking in drywall partitions where wall stops or other wall mounted hardware is located.
- C. Thresholds: Set thresholds for exterior and acoustical doors in full bed of sealant complying with requirements specified in Division 7 Section "Joint Sealants."

- D. Storage: Provide a secure lock up for hardware delivered to the project but not yet installed. Control the handling and installation of hardware items so that the completion of the work will not be delayed by hardware losses before and after installation.

3.4 FIELD QUALITY CONTROL

- A. Field Inspection: Supplier will perform a final inspection of installed door hardware and state in report whether work complies with or deviates from requirements, including whether door hardware is properly installed, operating and adjusted.

3.5 ADJUSTING

- A. Initial Adjustment: Adjust and check each operating item of door hardware and each door to ensure proper operation or function of every unit. Replace units that cannot be adjusted to operate as intended. Adjust door control devices to compensate for final operation of heating and ventilating equipment and to comply with referenced accessibility requirements.

3.6 CLEANING AND PROTECTION

- A. Clean work under provisions of 01 70 00.
- B. Protect all hardware stored on construction site in a covered and dry place. Protect exposed hardware installed on doors during the construction phase. Install any and all hardware at the latest possible time frame.
- C. Clean adjacent surfaces soiled by door hardware installation.
- D. Clean operating items as necessary to restore proper finish. and provide final protection and maintain conditions that ensure door hardware is without damage or deterioration at time of owner occupancy.

3.7 DEMONSTRATION

- A. Instruct Owner's maintenance personnel to adjust, operate, and maintain mechanical and electromechanical door hardware.

3.8 DOOR HARDWARE SCHEDULE

- A. The hardware sets represent the design intent and direction of the owner and architect. They are a guideline only and should not be considered a detailed hardware schedule. Discrepancies, conflicting hardware and missing items should be brought to the attention of the architect with corrections made prior to the bidding process. Omitted items not included in a hardware set should be scheduled with the appropriate additional hardware required for proper application and functionality.

3.9 COMPLETE HARDWARE INSTALLATION

- A. The following schedule listings cover typical openings. The Contractor shall be responsible for complete examination of the drawings and shall provide all hardware required. Any hardware necessary but not specifically mentioned herein shall be of the like quality, weight, design and finish as similar openings or items specified herein.
- B. Provide silencers on all new metal frames. Three on single leaf door frames, two on pairs of doors and four on double egress.
- C. Provide wall stops at all new door frame openings located in new partitions.
- D. Doors 42" in width are to use continuous geared hinges as specified below even if the door hardware schedule below does not list it.

3.10 HARDWARE SCHEDULE:

- A. Provide tactile warning on the levers leading into the following rooms: A105, A115, A118, A129, A129a, A204, B101, B102, B104, B106, B107, C112, C200, C204

HW-1 Aluminum Entrance Doors

Cylinders - Type and quantity as required

With security proximity reader.

See Section 08 42 13 - Aluminum Entrance Doors

HW-2 Aluminum Entrance Doors

Cylinders - Type and quantity as required

No security proximity reader.

See Section 08 42 13 - Aluminum Entrance Doors

HW-3 Single Egress Doors - with Key & Lever

1 Electrified Continuous hinge Roton 780-111 HD (or equal)

1 Electrified Exit Device 43 8876-24v ETL (electric latch retraction-coordinate w/ security system)

1 Closer

1 Door wiring harness

1 Frame wiring harness

1 Power supply

1 Kickplate

1 Stop

1 Access Control Proximity Reader

(Proximity Reader by Seco-Larm USA, Inc. (or equal) Model PR-2125-PQ Standard Wiegand Reader, weatherproof access control proximity card and fob reader)

Note: Door normally locked and closed. Entry by access control proximity reader or manual key override.

Free egress at all times.

(Note: General Contractor must ensure the low voltage wiring pertaining to the electrified exit device is installed in coordination with remainder of building wiring and connected to the security system and proximity reader.

Provide all electrical connections between building electrical and door equipment as required for a fully operational device.)

HW-4 Pair Egress Doors - with Key & Lever

1 Electrified Continuous hinge Roton 780-111 HD (or equal)

1 Continuous Geared Hinge Roton 780-111 HD (or equal)

1 Electrified Exit Device 43 NB8774-24v ETL
(electric latch retraction-coordinate w/ security system)

1 Exit Device NB8710 x ETL – Exit Only

2 Closers

1 Door wiring harness

1 Frame wiring harness

1 Power supply

2 Kickplates

2 Stops

1 Access Control Proximity Reader

(Proximity Reader by Seco-Larm USA, Inc. (or equal) Model PR-2125-PQ Standard Wiegand Reader, weatherproof access control proximity card and fob reader)

Note: Door normally locked and closed. Entry by access control proximity reader or manual key override. Free egress at all times.

(Note: General Contractor must ensure the low voltage wiring pertaining to the electrified exit device is installed in coordination with remainder of building wiring and connected to the security system and proximity reader.

Provide all electrical connections between building electrical and door equipment as required for a fully operational device.)

HW-5 Pairs Egress Doors with Lever & Key

Butts

1 Exit Device 16-8706 ETL

1 Exit Device 16-8710 x ETL – Exit Only

2 Closers

2 Kickplates

2 Stops

2 Silencers

HW-6 Exterior Pair Doors - with Key & Lever

1 Electrified Continuous hinge Roton 780-111 HD (or equal)

1 Continuous Geared Hinge Roton 780-111 HD (or equal)

1 Electrified Exit Device 43 8774-24v ETL
(electric latch retraction-coordinate w/ security system)

1 Pair flush bolts on inactive leaf

2 Closers with hold opens

1 Door wiring harness

1 Frame wiring harness

1 Power supply

2 Kickplates

2 Stops

1 Access Control Proximity Reader

(Proximity Reader by Seco-Larm USA, Inc. (or equal) Model PR-2125-PQ Standard Wiegand Reader, weatherproof access control proximity card and fob reader)

Note: Door normally locked and closed. Entry by access control proximity reader or manual key override. Free egress at all times.

(Note: General Contractor must ensure the low voltage wiring pertaining to the electrified exit device is installed in coordination with remainder of building wiring and connected to the security system and proximity reader.

Provide all electrical connections between building electrical and door equipment as required for a fully operational device.)

HW-7 Interior Single Doors with Storeroom Lock

Butts

1 Lockset 10G04

1 Closer with hold open

1 Stop

3 Silencers

HW-8 Interior Single Doors with Push/Pull

Butts

1 Push Plate

1 Door Pull

1 Closer

1 Kickplate

1 Stop

3 Silencers

HW-9 Interior Single Doors with Passage Set and Closer

Butts

1 Passage Set 10U15

1 Closer

1 Kickplate

1 Stop

3 Silencers

HW-10 Interior Single Doors with Office Lock

Butts

1 Lockset 10G05

1 Kickplate

1 Stop

3 Silencers

HW-11 Interior Single Doors with Storeroom Lock

(for elevator machine rooms)

(The key to enter the Elevator Machine Room is to be keyed separately from the remainder of the building and not be included in the building's master key system.)

Butts

1 Lockset 10G04

1 Closer

1 Stop

3 Silencers

HW-12 Interior Single Doors with Storeroom Lock

Butts

1 Lockset 10G04

1 Closer

1 Stop

3 Silencers

HW-13 Interior Pairs Doors with Inactive Leaf

Butts

1 Set Auto Flush Bolts

1 Lockset 10G04

1 Coordinator

2 Closers

2 Stops

2 Silencers

HW-14 Interior Pairs Doors with Storeroom Lock

Butts

2 Flush Bolts

1 Lockset 10G04

2 Closers

2 Stops

2 Silencers

HW-15 Single Private Toilet Room Doors with Mortise Privacy set & Indicator.

Butts

1 Privacy set 49-8265 (OCC/VAC indicator) (Sargent Mortise)

1 Closer

1 Kickplate

1 Wall Stop

3 Silencers

HW-16 Single Private Toilet Room Doors with Mortise Privacy set & Indicator.

Butts

1 Privacy set 49-8265 (OCC/VAC indicator) (Sargent Mortise)

1 Kickplate

1 Wall Stop

3 Silencers

HW-17 Interior Single Door with Push/Pull

Butts

1 Push Plate

1 Door Pull

1 Closer

1 Kickplate

1 Stop

3 Silencers

1 Electromagnetic Lock

1 Power Supply

1 Key Switch

2 Access Control Proximity Readers (one on each side of the door)

(Proximity Reader by Seco-Larm USA, Inc. (or equal) Model PR-2125-PQ Standard Wiegand Reader, weatherproof access control proximity card and fob reader)

Note: Door normally locked and closed. Entry by access control proximity reader or if fire alarm system turns-off mag lock.

(Note: General Contractor must ensure the low voltage wiring pertaining to the electromagnetic lock is installed in coordination with remainder of building wiring and connected to the security system, fire alarm system and proximity reader.

Provide all electrical connections between building electrical and door equipment as required for a fully operational device.)

HW-18 Interior Single Doors with Passage Set and Closer

Butts

1 Passage Set 10U15

1 Closer with hold-open

1 Kickplate

1 Stop

3 Silencers

HW-19 Interior Pair Doors with Push/Pull

Butts

2 Push Plates

2 Door Pulls

2 Closers with hold-opens

2 Kickplates

2 Stops

2 Silencers

HW-20 Interior Single Doors with Storeroom Lock

Butts

1 Lockset 10G04

3 Silencers

HW-21 Interior Pairs Doors with Office Lock

Butts
2 Flush Bolts
1 Lockset 10G05
2 Closers with hold-open
2 Stops
2 Silencers

HW-22 Interior Single Doors, push, double acting

1-1/2 pair of double acting, full surface, spring hinges, 6 inch.
2 Push Plates
2 Kickplates (36" high x 2" less than nominal door width)
1 Deadlock 485 Sargent
2 Stops

HW-23 Interior Pairs Doors with Office Lock

Butts
2 Flush Bolts
1 Lockset 10G05
2 Kickplates
2 Stops
2 Silencers

HW-24 Exterior Pairs Doors with Storeroom Lock

2 Continuous Geared Hinges Roton 780-111 HD (or equal)
2 Flush Bolts
1 Lockset 10G04
2 Closers
2 Stops
2 Silencers

HW-25 Interior Single Doors with Office Lock

Butts
1 Lockset 10G05
1 Closer
1 Kickplate
1 Stop
3 Silencers

END OF SECTION

THIS PAGE INTENTIONALLY LEFT BLANK

SECTION 08 71 50

WEATHERSTRIPPING

PART 1 - GENERAL

1.01 SECTION INCLUDES

- A. The furnishing and installation of all door weatherstripping, sound and smoke proofing.

1.02 RELATED SECTIONS

- A. 08 12 13 - Steel Door Frames
- B. 08 13 13 - Steel doors
- C. 08 42 13 – Aluminum Entrance doors

1.03 DESIGN REQUIREMENTS

- A. All work not shown or specified but required to complete the installation shall be provided.
- B. Provide and install weatherstripping on all new exterior doors.

1.04 SUBMITTALS

- A. Submit under provisions of Section 01 33 00.
- B. Shop drawings: Indicate various styles with model numbers and manufacturer.
- C. Provide samples if asked for by Architect.

1.05 QUALIFICATIONS

- A. Installer: Products specified under this section shall be installed by competent tradesmen experienced in this work.

1.06 REGULATORY REQUIREMENTS

- A. Work shall satisfy requirements of government agencies having jurisdiction.
- B. All thresholds to comply with the state building code and ANSI A117.1.

1.07 DELIVERY, STORAGE, AND HANDLING

- A. Deliver, store, protect and handle products to site under provisions of Section 01 60 00.

1.08 FIELD MEASUREMENTS

- A. Field verify all dimensions prior to installation.

1.09 WARRANTY

- A. Provide one year warranty under provisions of Section 01 78 00.

PART 2 - PRODUCTS

2.01 MANUFACTURERS

- A. Pemko
- B. Other acceptable manufacturers offering equivalent products.
 - 1. Accurate Metal Weatherstrip Co., Inc.
 - 2. Zero International, Inc.
- C. Substitutions: Under provisions of Section 01 60 00.

2.02 MATERIALS

- A. Exterior outswinging metal doors with metal jamb.
 - 1. Head and jambs: 316DPK
 - 2. Sweep: 315DN
 - 3. Threshold: 252X3AFG (thermal break)
 - 4. Astragal: 18041DP
- B. Exterior in swinging metal doors with metal jamb
 - 1. Head and jambs: 316DPK
 - 2. Door Shoe: 222DV
 - 3. Threshold: 252X3AFG (thermal break)
- C. Aluminum Doors
 - 1. Sweep: 315_N (Finish to match door)
 - 2. Threshold: 252X3AFG (thermal break)

PART 3 - EXECUTION

3.01 INSTALLATION

- A. Weatherstripping shall be applied in accordance with manufacturers specifications. Thresholds shall be set in elastic cement and held in place with rawl plugs and aluminum screws.

3.02 DISSIMILAR MATERIALS

- A. Where aluminum surfaces come in contact with metals other than stainless steel, zinc, white bronze or other metals compatible with aluminum, aluminum surfaces shall be kept from direct contact with such parts by (a) painting the dissimilar metal with a coating of heavy bodied bituminous paint, (b) a good quality caulking placed between aluminum and dissimilar metal, or (c) a non-absorptive tape or gasket.

3.03 ADJUSTMENTS

- A. Adjust weatherstripping as required to provide proper weatherproofing.
- B. Gaskets and/or caulking shall be provided as required for a proper installation.

3.04 CLEANING

- A. Clean work under provisions of Section 01 70 00.

END OF SECTION

THIS PAGE INTENTIONALLY LEFT BLANK

SECTION 08 81 00

GLASS AND GLAZING

PART 1 - GENERAL

1.01 SUMMARY

- A. Related Documents:
The Drawings and general provisions of the Contract, including General and Supplementary General Conditions, and Division 1 Requirements, apply to the work in this Section.

1.02 SCOPE: Provide all glass and glazing work complete in accordance with the Specifications and Drawings.

1.03 RELATED SECTIONS

- A. Section 08 12 13 – Steel Door Frames
- B. Section 08 13 13 - Steel Doors
- C. Section 08 14 16 - Wood Doors
- D. Section 08 42 13 – Aluminum Entrance Doors
- E. Section 08 43 13 – Aluminum Storefront System

1.04 REFERENCES

- A. ANSI Z97.1 - Safety Performance Specifications and Methods of Test for Safety Glazing Material Used in Buildings.
- B. ASTM E84 - Surface Burning Characteristics of Building Materials.
- C. FS DD-G-451 - Glass, Float or Plate, Sheet, Figured (Flat, for Glazing, Mirrors and Other Uses).
- D. FS DD-G-1403 - Glass, Plate (Float), Sheet, Figured, and Spandrel (Heat Strengthened and Fully Tempered).
- E. SIGMA No. 64-7-2 - Specification for Sealed Insulating Glass Units.
- F. FGMA - Glazing Manual.

1.05 SUBMITTALS

- A. Submit product data under provisions of Section 01 33 00.
- B. Provide structural, physical and environmental characteristics, size limitations, special handling or installation requirements.
- C. Provide data on glazing sealant. Identify colors available.
- D. Submit samples under provisions of Section 01 33 00.
- E. Submit samples of each type glass and each type glazing material.
- F. Submit sealed glass unit manufacturer's certificate under provisions of Section 01 33 00 indicating units meet or exceed specified requirements.

1.06 DELIVERY, STORAGE, AND PROTECTION

- A. Deliver products to site under provisions of Section 01 60 00.
- B. Store and protect products under provisions of Section 01 60 00.

1.07 WARRANTY

- A. Provide ten year warranty under provisions of Section 01 78 00.
- B. Warranty: Include coverage of sealed glass units from seal failure, interpane dusting or misting, and replacement of same.

PART 2 - PRODUCTS

2.01 MANUFACTURERS

- A. Subject to compliance with requirements of this Specification Section, provide products listed herein from one of the following (unless noted from a different manufacturer below):
 - 1. Viracon
 - 2. Vitro Architectural Glass
 - 3. Guardian
- B. Substitutions under provisions of Section 01 60 00.

2.02 GLASS MATERIALS

- A. Safety Glass:
FS DD-G-1403; Kind ft., 1/4" Type 1, tempered. Listed in door schedule as "Temp".
- B. Exterior Insulated Glass
 - 1. 1" insulated - 1" thick (1/4" glass, 1/2" airspace, 1/4" glass), hermetically sealed, low "E".
 - Exterior pane of glass tinted. Gray tint. Shade of gray tint to be selected by Architect from manufacturer's standards.
 - Glass to be tempered as required by the code.
 - CBA rated and certified.
 - a. Glass is to meet the following National Fenestration Rating Council (NFRC) testing in accordance with the RI State Building Code SBC-8 State Energy Conservation Code
 - 1. NFRC 100; Procedure for Determining Fenestration Thermal Properties:
The conductive thermal transmittance (U-Factor) shall not be more than:
 - a. 0.38 BTU/hr/sf/°F at fixed storefront window systems.
 - b. 0.45 BTU/hr/sf/°F at operable window systems.
 - c. 0.77 BTU/hr/sf/°F at exterior doors.
 - 2. NFRC 200; Solar Heat Gain Coefficient and Visible Transmittance:
Solar Heat Gain Coefficient (SHGC): shall not be more than 0.40 at all fenestrations.

- C. Impact Resistant Glass for Aluminum Entrance Doors and Aluminum Storefront Systems
 - 1. Glass shall be 1" insulated (1/4" heat strengthened glass, airspace, 1/2" laminated glass with 0.1 polyvinyl butyral; Stormguard by Viracon or equal), impact resistant glazing for withstanding Large Missile Impact meeting ASTM E1996, hermetically sealed, low "E", tinted, CBA rated and certified.
Color of glass tint to be selected by Architect from manufacturer's standard colors.

2.03 ACCESSORIES

- A. Glazing Compound, Tape and Sealant:
 - 1. Compound - Tremco Glazing Compound or approved equal.
 - 2. Tape - Tremco Polyisobutylene #440 or approved equal.
 - 3. Sealant - Tremco Mono Sealant or approved equal.
- B. Setting Blocks and Spacers shall be provided of resilient types and materials as recommended by the manufacturer of the glass or glazing materials.

2.04 MANUFACTURER'S LABELS:

Manufacturer's labels showing strength, grade, thickness, type and quality will be required on each piece of glass. Labels must remain on glass until it has been set and inspected. Glazing materials shall be delivered to the site in unopened original containers bearing manufacturer's label specifying the quality, brand, trade name and directions for use. Thinners or additives shall not be used for glazing materials unless specifically recommended by the manufacturer.

Safety glass must bear a permanent visible mark indicating such.

PART 3 - EXECUTION

3.01 INSTALLATION:

- A. General: Surfaces of rabbets, glass edges and stops or beads shall be clean, dry, free from dust, oil, rust and loose paint. Metal surfaces shall be wiped clean with solvent recommended by the manufacturer. Glazing materials shall not be applied in temperature below 40 degrees F. or during damp or rainy weather. Glass shall be set without springing or forcing. Glazing compound shall be applied in accordance with the recommendations of the manufacturer. Centered position and compound thickness shall be maintained. Setting blocks at the sills and centering shims inside and out on all four sides of glass shall be provided.
- B. All glass shall be installed in accordance to the recommendations of the Flat Glass Jobber's Association Glazing Manual and the glass manufacturer.
- C. Wood Doors: Glass shall be held in place with wood glazing stops. Glazing shall be done after doors have been installed and surfaces primed and are thoroughly dry. Glass shall be of proper size to obtain the required edge clearances. Glass shall rest on setting blocks and the entire perimeter of the glass shall be bedded in glazing compound. Edge and face clearances shall be maintained uniform. Glazing compound shall fill rabbet solidly with the stop bead in place. Stop bead shall be fastened with screws. Surplus glazing compound shall be removed from both sides of glass at an angle.

D. Glazing in Metal Frames: Glazing shall be of the snap-in type and shall have no exposed fasteners except that glazing in metal frames shall be of the applied type. Glazing shall not be done until frames have been set and adjusted. Glass shall be of proper size, rest on setting blocks and the entire perimeter of the glass shall be bedded in glazing compound. Edge and face clearances shall be maintained uniform and spacers shall be provided. Glazing compound shall fill rabbet solidly with the snap-in bead in place. After bead is in place surplus glazing compound shall be removed from both sides of glass at an angle, so as not to undercut.

3.02 CLEANING: Glass shall be cleaned on both sides of surplus glazing material. Glazing materials shall not be disturbed with scrapers. Acid solutions or water containing caustic soaps shall not be used. Broken and cracked glass and glass not complying with the specifications shall be replaced.

3.03 GLASS SCHEDULE: (See plans for locations)

<u>LOCATION</u>	<u>GLASS</u>
Interior Window (vision panel) Non Rated	Safety Glass
Interior Entrance Doors	Safety Glass
Interior Storefront Windows	Safety Glass
Interior Doors Non Rated	Safety Glass
Exterior Entrance Doors (Upper Floor Level only)	Impact Resistant Glass
Exterior Storefront Windows (Upper Floor Level only)	Impact Resistant Glass
Exterior Entrance Doors (Lower Floor Level only)	Exterior Insulated Glass
Exterior Storefront Windows (Lower Floor Level only)	Exterior Insulated Glass
Interior Sliding Shelter Doors	Exterior Insulated Glass (No tint)

END OF SECTION

SECTION 08 81 13

DECORATIVE GLASS GLAZING

PART 1 - GENERAL

- 1.1 Summary
 - A. Section Includes: Laminated glass with color interlayer.
 - B. Related Sections:
 - 1. Section 07 92 13 – Joint Sealants
 - 2. Section 08 12 13 – Steel Door Frames
 - 3. Section 08 81 15 - Decorative Glass Glazing Panel Wall Frame.
- 1.2 References
 - A. ASTM International
 - 1. ASTM C 1036 Specification for Flat Glass
 - 2. ASTM C 1048 Specification for Heat-Treated Flat Glass-Kind HS, Kind FT Coated and Uncoated Glass
 - 3. ASTM C 1172 Specification for Laminated Architectural Flat Glass
 - 4. ASTM E 774 Specification for Sealed Insulating Glass Units where insulating glass is specified
 - B. ANSI - American National Standards Institute
 - 1. ANSI Z 97.1 Safety Performance Specifications and Methods of Test Used in Buildings
 - 2. CPSC 16 CFR 1201 Safety Standard for Architectural Glazing Materials, Category I and II
- 1.3 Submittals
 - A. Submit under provisions of Section 01 33 00.
 - B. Submit manufacturer's shop drawings, installation drawings, installation instructions and maintenance instructions.
 - C. Submit environmental impact data for all materials.
 - D. Submit samples no less than 6" x 6" for all specified glass configurations.
 - E. Manufacturer information:
 - 1. Provide overview literature describing manufacturer's overall scope of products and manufacturing capabilities.
 - 2. Provide URL for manufacturer's web site; web site must provide access to technical data, images and general product information.
- 1.4 Quality Assurance
 - A. Manufacturer Qualifications
 - 1. Minimum 10 years experience in the manufacture of laminated glass.
 - 2. Provide test reports indicating products meet or exceed specified requirements.

- B. Installer Qualifications
 - 1. Minimum three years experience in the installation of glass.
- 1.5 Delivery, Storage and Handling
 - A. Deliver, store, protect and handle products to site under provisions of Section 01 60 00.
 - B. Deliver materials to installation site in manufacturer's original packaging. Handle products in accordance with manufacturer's instructions. Store in dry, secure location, protected against direct sunlight and excessive heat. Protect finished surfaces with strippable film.
- 1.6 Warranty
 - A. Provide manufacturer's standard warranty under the provisions of Section 01 78 00.
 - 1. Warranty terms: one year against defects in materials and workmanship.

PART 2 - PRODUCT

- 2.1 Manufacturer
 - A. Forms+Surfaces
30 Pine Street
Pittsburgh, PA 15223
phone: 800-451-0410
fax: 412-385-4715
email: mike.kelly@forms-surfaces.com
website: www.forms-surfaces.com
 - B. Substitutions: Under provisions of Section 01 60 00.
- 2.2 ViviSpectra Spectrum Laminated Glass
 - A. Material
 - 1. Configuration: VGS3417-1210-GP
 - 2. Pattern: Custom Photography provided by the Owner.
 - 3. Finish: Pearlex+
 - 4. Translucency: Lumilevel #4
 - 5. Processing: polished edges
 - 6. Overall Nominal Thickness: 14 mm
 - 7. Fire rating: ViviSpectra Spectrum glass is Class A fire rated in accordance with ASTM designation E84-09, standard test method of surface burning characteristics of building materials. The foregoing test procedure is comparable to UL 723, ANSI/NFPA No. 255, and UBC No. 8-1.
- 2.3 Associated Components
 - A. Top Lite
 - 1. Type: Annealed
 - 2. Thickness: 6.0 mm
 - 3. Class: Low Iron
 - B. Bottom Lite
 - 1. Type: Annealed
 - 2. Thickness: 6.0 mm

- 3. Class: Low Iron
- C. Interlayer
 - 1. Design: Manufactured by VividGlass, a Forms+Surfaces company.
 - 2. Thickness: 2 mm.

PART 3 - EXECUTION

3.1 Preparation

- A. Protect glass and equipment from damage caused by work of this Section.

3.2 Installation

- A. Install ViviSpectra Spectrum glass in accordance with manufacturer's instructions at locations indicated on the drawings.
- B. The decorative glass is to be installed in two different configurations.
 - 1. One type of installation is in metal sidelight door frames.
 - 2. The other type of installation is against the face of a wall using the aluminum framing system specified in Section 08 81 15 - Decorative Glass Glazing Panel Wall Frame.

3.3 Cleaning and Protection

- A. Protect laminated glazing in accordance with GANA Glazing Manual.
- B. Clean laminated glazing materials in accordance with GANA Bulletin 01-0300.

END OF SECTION

THIS PAGE INTENTIONALLY LEFT BLANK

SECTION 08 81 15

DECORATIVE GLASS GLAZING PANEL WALL FRAME

PART 1 - GENERAL

- 1.1 Summary
- A. Section Includes: Pre-engineered wall cladding system including wall panels, mounting extrusions, bases and frame. Wall system comes “ready to install” with fasteners, adhesives, and other materials required for a complete assembly. Fasteners shall be concealed type.
- 1.2 References
- A. ASTM E84 – Surface Burning Characteristics of Building Materials.
- B. Related Specification Sections:
08 81 13-Decorative Glass Glazing
- 1.3 Submittals
- A. Submit under provisions of Section 01 33 00.
- B. Submit manufacturer’s shop drawings, installation drawings, installation instructions and maintenance instructions.
- C. Submit environmental impact data for all materials.
- D. Submit samples no less than 4" x 4" for all specified material finishes.
- E. Submit panel edge extrusion samples no less than 4" of specified finish.
- F. Submit mock-up of wall system no less than 12" x 12".
- G. Manufacturer information:
1. Provide overview literature describing manufacturer’s overall scope of products and manufacturing capabilities.
 2. Provide URL for manufacturer’s web site; web site must provide access to technical data, images and general product information.
- 1.4 Quality Assurance
- A. Manufacturer Qualifications
1. Minimum 10 years experience in the manufacture of architectural surface materials.
 2. Minimum 10 years experience in the fabrication of wall systems.
 3. Provide reference list of at least 10 public space projects currently using walls fabricated by the manufacturer.
- B. Installer Qualifications
1. Minimum three years experience in the installation of wall systems.

1.5 Delivery, Storage and Handling

- A. Deliver, store, protect and handle products to site under provisions of Section 01 60 00.
- B. Deliver materials to installation site in manufacturer's original packaging. Handle products in accordance with manufacturer's instructions. Store in dry, secure location, protected against direct sunlight and excessive heat. Protect finished surfaces with strippable film.

1.6 Warranty

- A. Provide manufacturer's standard warranty under the provisions of Section 01 78 00.
 - 1. Warranty terms: one year against defects in materials and workmanship.

PART 2 - PRODUCT

2.1 Manufacturer

- A. Provide LEVELe Wall Cladding System by Forms+Surfaces
30 Pine Street, Pittsburgh, PA 15223
phone: 800-451-0410
fax: 412-385-4715
email: sales@forms-surfaces.com
website: www.forms-surfaces.com
- B. Substitutions: Under provisions of Section 01 60 00.

2.2 Wall Cladding System

- A. General
 - 1. Provide interlocking grid panel system with inset panels mounted to extruded aluminum frames.
 - 2. Panel configuration: Forms+Surfaces' LEVELe Wall Cladding System with Capture style panel frames. See drawings for panel layout.
 - 3. Provide inset glass panels as specified in Section 08 81 13 - Decorative Glass Glazing.
 - 4. Frames are extruded aluminum. Aluminum is inherently non-combustible.
 - 5. Laminated Glass Panels
 - a. Material: ViviSpectra Spectrum Laminated Glass
 - b. Fire rating: VividGlass glass is Class A fire rated in accordance with ASTM designation E84-09, standard test method of surface burning characteristics of building materials. The foregoing test procedure is comparable to UL 723, ANSI/NFPA No. 255, and UBC No. 8-1.
- B. Panel Frames
 - 1. Material: Extruded, anodized aluminum

2. Finish: Clear anodized.
- C. Corners and End Stops (as required)
 1. Material: Extruded, anodized aluminum
 2. Finish: Clear anodized.

PART 3 - EXECUTION

3.1 Preparation

- A. Protect column finishes, fixtures and equipment from damage caused by work of this Section.

3.2 Installation

- A. Install in accordance with column system manufacturer's instructions.

3.3 Cleaning and Protection

- A. Remove strippable film. Clean exposed surfaces in accordance with manufacturer's instructions.
- B. Protect exposed surfaces from damage by subsequent construction.

END OF SECTION

THIS PAGE INTENTIONALLY LEFT BLANK

SECTION 08 87 23

SECURITY GLAZING FILM

PART 1 - GENERAL

1.01 SECTION INCLUDES

- A. Security glazing film applied to as part of manufactured window units specified in other sections.

1.02 RELATED SECTIONS

- A. Section 08 54 13 - Fiberglass Window

1.03 REFERENCES

- A. American Society for Testing and Materials (ASTM) D4830 - Standard Test Methods for Characterizing Thermoplastic Fabrics Used in Roofing and Waterproofing.
- B. ASTM E84 - Standard Test Method for Surface Burning Characteristics of Building Materials.
- C. ASTM E330 - Standard Test Method for Structural Performance of Exterior Windows, Curtain Walls, and Doors by Uniform Static Air Pressure Difference
- D. ASTM F1642 - Standard Test Method for Glazing and Glazing Systems Subject to Airblast Loadings
- E. American National Standards Institute (ANSI): ANSI Z97.1(CPSC 1201) Safety Glazing Materials Used In Buildings.
- F. H. P. White Laboratory, Inc., Ballistic Resistance Test HPW-TP-0500.02.
- G. WBE Engineering, Inc., Test Program for Evaluation of Filmed Windows Subjected to Blast Loads, Test Report 817-001.

1.04 SUBMITTALS

- A. Product Data, including certified third party test data indicating compliance with specified requirements, and provider's recommended installation procedures.
- B. Samples for Selection: Full range of available tinted film colors.
- C. Fabricator/applicator qualifications as required by Quality Assurance article.
- D. Provider's sample warranty.
- E. Maintenance and cleaning instructions.

1.05 QUALITY ASSURANCE

- A. Applicator: Experienced applicator firm approved and certified by provider of security and safety glazing film.
- B. Regulatory Requirements: Comply with requirements of applicable building code.
- C. Field Sample: Apply proposed security glazing film to glass units identical to those utilized in project as requested by Architect.

1.06 WARRANTY

- A. Provide provider's standard limited warranty, covering replacement film materials and film installation labor, against adhesive failure, film discoloration and distortion, peeling or delamination, and on film-protected units that are intentionally broken, for the life of the installation.

PART 2 - PRODUCTS

2.01 MANUFACTURERS

- A. ShatterGARD, Inc., 8351 Roswell Road Suite 196, Atlanta, GA 30350;
Voice: (888) 306-7998; Fax: (678) 352-8913.
- B. Substitutions: Under provisions of Section 01 60 00.

2.02 MATERIALS

- A. Security Glazing Film: BlastGARD 15: .015 inch thick
 - 1. Optically clear, tear-resistant, penetration-resistant, and abrasion-resistant polyester film with pressure-sensitive adhesive, complying with the following:
 - 2. Puncture resistance per ASTM D4830.
 - 3. Visible Light Transmittance (film only): 85 percent.
 - 4. Total Ultraviolet Rejected (film only): 99 percent.
 - 5. Total Solar Energy Rejected (film only): 21 percent

PART 3 - EXECUTION

3.01 EXAMINATION

- A. Examine glazing surfaces to receive security glazing film application. Report conditions detrimental to application of film in writing to Architect. Do not apply film to substrates until approved.

3.02 PREPARATION

- A. Clean glass substrates in accordance with provider's instructions. Test substrate after cleaning for adhesion when recommended.

3.03 APPLICATION

- A. Install security glazing film in all locations noted below in the schedule.
- B. Install security glazing film to interior side of inboard glass lite glazing units indicated.
- C. Apply security glazing film in strict accordance with provider's written installation instructions. Apply film to prepared glass surface, ensuring complete adhesion of film.
- D. Film Edge Condition: Apply film with edge condition indicated.
 - 1. Apply film to daylight glass opening, from stop to stop with clear silicone glazing sealant bead at perimeter of film/glazing stop joint. Trim film neatly at perimeter within 1/8 inch of stop or frame.

3.04 CLEANING AND PROTECTION

- A. Do not disturb or clean film for minimum 30 days following application. Delay cleaning film until bubbles of temporarily trapped moisture are no longer visible behind film.
- B. Clean film in accordance with provider's instructions. Leave film and adjoining finishes free of fingerprints, adhesive, or other surface blemish resulting from this application.
- C. Protect film from damage due to construction operations.

3.05 SCHEDULE

- A. Provide and install Security Glazing Film on all fiberglass windows on the Upper Floor Level of the Education Center.

END OF SECTION

THIS PAGE INTENTIONALLY LEFT BLANK

SECTION 08 88 13

FIRE-RATED GLASS

PART 1 - GENERAL

1.01 SUMMARY

- A. Section Includes:
 - 1. Fire-rated glazing materials installed as transoms, door lites, borrowed lites or windows in fire-rated frames
- B. Related Sections:
 - 1. Section 08 12 13 – Steel Door Frames
 - 2. Section 08 13 13 – Steel Doors
 - 3. Section 08 14 16 – Wood Doors

1.02 REFERENCES

- A. ASTM E 119 - Fire Tests of Building Construction Materials.
- B. ASTM E 2010 - Standard Test Method for Positive Pressure Fire Tests of Window Assemblies.
- C. ASTM E 2074 - Standard Test Method for Fire Tests of Door Assemblies, Including Positive Pressure Testing of Side-Hinged and Pivoted Swinging Door Assemblies.
- D. CSFM - Fire Tests for Doors and Window Assemblies.
- E. GANA - Glazing Manual.
- F. GANA - Sealant Manual.
- G. NFPA 80 - Fire Doors and Windows.
- H. NFPA 251 - Fire Test for Fire Endurance of Building Construction and Materials.
- I. NFPA 252 - Standard Methods of Fire Tests of Door Assemblies.
- J. NFPA 257 - Standard on Fire Test for Window and Glass Block Assemblies.
- K. UBC Standard 7-1 - Fire Test of Building Construction and Materials.
- L. UBC Standard 7-2 - Fire Tests of Door Assemblies (Positive Pressure).
- M. UBC Standard 7-4 - Fire Tests of Window Assemblies.
- N. UL 9 - Fire Tests of Window Assemblies.
- O. UL 10C - Positive Pressure Fire Tests of Door Assemblies.
- P. UL 10B - Fire Tests of Door Assemblies.
- Q. UL 263 - Fire Resistance Ratings.

1.03 SUBMITTALS

- A. Comply with requirements of Section 01 33 00
- B. Product Data: Submit manufacturer's technical data for each glazing material required, including installation and maintenance instructions.
- C. Certificates of compliance and glazing materials from glass and glazing materials manufacturers attesting that glass and glazing materials furnished for project comply with requirements. Separate certification will not be required for glazing materials bearing manufacturer's permanent label designating type and thickness of glass, provided labels represent a quality control program involving a recognized certification agency or independent testing laboratory acceptable to authority having jurisdiction.
- D. Product test Listings: from a qualified testing agency indicating fire-rated glass complies with requirements, based on comprehensive testing of current product.
- E. Samples: Submit, for verification and approval purposes, approx. 8" x 10" sample for each type of glass indicated.

1.04 QUALITY ASSURANCE

- A. Glazing Standards: GANA Glazing Manual and Sealant Manual
- B. Each lite shall bear a permanent, non-removable label of Underwriters Laboratories and/or Intertek Testing Services (Warnock-Hersey) certifying it for use in tested and rated fire protective assemblies.

1.05 DELIVERY, STORAGE, and HANDLING

- A. Deliver, store and handle materials under provisions of Section 01 60 00
- B. Deliver materials to specified destination in manufacturer's or distributor's packaging, undamaged, complete with installation instructions.
- C. Store off ground, under cover, protected from weather and construction activities.

1.06 WARRANTY

- A. Provide manufacturer's three year limited warranty under provision of Section 01 78 00

PART 2 -PRODUCTS

2.01 FIRE RATED GLAZING MATERIALS

- A. Manufacturer: Vetrotech Saint-Gobain NA, Auburn, WA
- B. Other acceptable manufacturers offering equivalent products.
 - 1. Technical Glass Products

2. Safti First

C. Substitutions: Under provisions of Section 01 60 00.

2.02 MATERIALS

A. Fire/safety rated glass with safety film properties (Keralite F):
 Listed in door schedule as "FR/SFTY".

1. Thickness: 3/16"
2. Weight: 2.7 lbs / sq. ft.
3. Approx. visible light transmission: 86%
4. Impact Safety Rating: ANSI Z97.1 and CPSC 16CFR1201 (CAT I & II)
5. Film: 3M Scotchshield Ultra Safety and Security Film.
6. Fire-Rating Testing: Fire rating tested and listed by Intertek Testing Services (Warnock-Hersey) or Underwriters Laboratories; tested in accordance with UBC Standard 7-2, UBC Standard 7-4, UL 9, UL 10c, NFPA 252, NFPA 257, ASTM E 2010, and ASTM 2074.
7. Maximum allowable sizes are as follows:

Thickness	Assembly	Max. Exposed Area (sq. in.)	Max. Width Exposed	Max. Height Exposed	Stop Height
3/16"					
	Doors Non Temp Rise (20 & 45-minutes)	3,627 sq. in.	46 1/2"	78"	5/8"
	Borrowed Lites (20 & 45 minutes)	3,627 sq. in.	46 1/2"	78"	5/8"
	Doors Non Temp Rise (60 minutes)	3,627 sq. in.	46 1/2"	78"	5/8"
	Doors Temp Rise (60 Minutes)	100 sq. in.	10"	33"	5/8"
	Borrowed Lites (60 minutes)	3,627 sq. in.	46 1/2"	78"	5/8"
	Doors Non Temp Rise (90 minutes)	3,534 sq. in.	46 1/2"	76"	5/8"
	Doors Temp Rise (90 Minutes)	100 sq. in.	10"	33"	5/8"
	Borrowed Lites (90 minutes)	2,736 sq. in.	60 1/4"	76"	5/8"

- B. Labeling: Permanently label each lite with laboratory logo (WHI and/or UL), product and manufacturer's name and fire rating.
- C. Fire Rating: Fire-rating listed and tested by Intertek Testing (WHI) for fire scheduled at opening locations on drawings, when tested in accordance with (ASTM E-152) (ASTM E-163) (UBC Standards 7-2 and 7-4) (NFPA 252 & 252) (UL 9 & UL10C)

2.02 GLAZING COMPOUND

- A. Glazing Tape: Closed cell polyvinyl chloride (PVC) foam tape, with adhesive on two sides.
- B. Silicone Sealant: one-part neutral curing silicone
 - 1. Dow Corning 795 – Dow Corning Corp.
 - 2. Siliglaze-II 2800 – General Electric CO.
 - 3. Spectrum 2 – Tremco Inc.
- C. Setting Blocks: Neoprene, EPDM, calcium silicate, or hardwood; as tested for compatibility with glazing compound.
- D. Cleaner, Primer, and Sealant: Type recommended by manufacturer of glass and gaskets.

2.03 FABRICATION

- A. Fabricate glass and other glazing products in sizes required to glaze openings indicated for project, with edge and face clearances, edge and surface conditions, and bite complying with recommendations of product manufacturer and referenced glazing standard as required to comply with system performance requirements.

PART 3 - EXECUTION

3.01 EXAMINATION

- A. Examine glass and framing, with glazier present, for compliance with the following:
 - 1. Manufacturing and installation tolerances, including this for size, squareness, offsets at corners.
 - 2. Minimum required face or edge clearances
 - 3. Observable edge damage or face imperfections.
- B. Do not proceed with glazing until unsatisfactory conditions have been corrected.
- C. Clean glazing channels and other framing members receiving glass immediately before glazing. Remove coatings that are not firmly bonded to substrates.

3.02 INSTALLATION (GLAZING)

- A. Comply with referenced GANA glazing manual and instructions of manufacturers of glass, glazing sealants, and glazing compounds.
- B. Protect glass from edge damage during installation and handling.

- C. Inspect glass during installation and set aside pieces with edge damage that could affect performance.
- D. Set units of glass in each series with uniformity of pattern, draw, bow and similar characteristics.
- E. Cut glazing tape to length and set against permanent stops, flush with sight lines to fit openings exactly, with stretch allowance during installation.
- F. Place setting blocks located at quarter points of glass with edge block no more than 8 inches from corner.
- G. Do not restrict movement due to thermal expansion.
- H. Direct glass-to-perimeter frame contact is prohibited.
- I. Glaze vertically into labeled doors or frames or partition walls with same fire rating as glass and push against tape for full contact at perimeter of pane or unit.
- J. Place glazing tape on free perimeter of glazing with same fire rating as glass and push against tape for full contact at perimeter of pane or unit.
- K. Do not remove protective edge tape.
- L. Install removable stop and secure without displacing tape or glazing compound.
- M. Knife trim protruding tape.
- N. Apply cap bead of silicone sealant along void between glass stop and glazing, to uniform line, with bevel to form watershed away from glass. Tool or wipe surface smooth.
- O. Do not pressure glaze.
- P. Install in vision panels in doors to requirements of NFPA 80. Install so that required markings remain visible.

3.03 PROTECTION AND CLEANING

- A. Protect glass from contact with contaminating substances resulting from construction operations. Remove any such substances by methods approved by manufacturer.
- B. Wash glass on both faces not more than four days prior to date scheduled for inspections intended to establish date of substantial completion. Wash glass by method recommended by glass manufacturer.

END OF SECTION

THIS PAGE INTENTIONALLY LEFT BLANK

SECTION 08 91 10

METAL LOUVERS

PART 1 - GENERAL

1.01 SUMMARY

- A. Related Documents:
The Drawings and general provisions of the Contract, including General and Supplementary General Conditions, and Division 1 Requirements, apply to the work in this Section.

1.02 SECTION INCLUDES

- A. Fixed metal wall louvers, accessories and subsills.

1.03 RELATED WORK

- A. Section 07 92 13-Joint Sealants

1.04 REGULATORY REQUIREMENTS

- A. Conform to State Building Code.

1.05 SUBMITTALS

- A. Submit shop drawings and product data under provisions of Section 01 31 00.
- B. Finish color samples on type of metal specified for louver.
- C. Submit manufacturer's installation instructions under provisions of Section 01 33 00.

1.06 DELIVERY, STORAGE AND PROTECTION

- A. Protect products under provisions of Section 01 60 00.
- B. Protect metal louvers with resilient packaging sealed with heat shrunk plastic.

1.07 WARRANTY

- A. Provide paint finish 20 year warranty.

PART 2 - PRODUCTS

2.01 MANUFACTURERS

- A. Subject to compliance with requirements of this Specification Section, provide products listed herein from one of the following:
 1. Airolite
 2. Construction Specialties, Inc.

3. Industrial Louvers, Inc.
- B. Basis of Design: Construction Specialties, Inc.
- C. Substitutions: Under provisions of Section 01 60 00.

2.02 MATERIALS

- A. Provide RS-5300 high performance louver by Construction Specialties, Inc.
- B. Storm proof (storm resistant), fixed, horizontal louver. Architectural louvers:
 1. Material: Extruded structural aluminum.
 2. Thicknesses:
 - a. Heads, sills, jambs, mullions, frames: 0.080 inch.
 - b. Blades: 0.060 inch thick or more.
 3. Heads, sills, jambs, mullions: One piece with integral caulking slot, retaining beads.
 4. Subsills: Required.
 5. Mullions: Provide sliding interlock.
 6. Blades: One piece, drainable, with water stop at top of blade.
 7. Depth: 5.00 inches.
 8. Drainable: Yes.
 9. Bird screen: Required.
 10. Insect screen: Required
 11. Stormproof: Yes.
 12. Color: To be selected by Architect from manufacturer's standard colors.
- C. FABRICATION
 1. Blades: Extruded aluminum sections of 6063 - T5 alloy.
 2. Supports: All blades to be supported and lined up by means of heavy gauge extruded aluminum blade braces positively interlocked to each blade and secured to structural steel by type 302 stainless steel fastenings. Structural supports to be designed to carry wind pressures not less than code- mandated loads. At corners, blades shall be mitered and continuously heliarc welded.
 3. Finishes (factory applied): Fluoropolymer coating meeting AAMA 2605.
 4. Blank-Off Panels: Provide 1" thick aluminum faced painted insulated blank-off panels where ducts do not equal louver size.
 5. Bird screen: Provide at all louver areas not having blank-off panels.
 6. Subsills: Provide at all louvers.

PART 3 - EXECUTION

3.01 INSTALLATION

- A. Install per manufacturer's recommendations and written installation instructions to structural back-up. Where necessary apply bitumin between dissimilar metals.
- B. Comply with manufacturer's instructions and recommendations for installation of the work.

- C. Verify dimensions of supporting structure at the site by accurate field measurements so that the louvers will be accurately designed, fabricated and fitted to the structure.
- D. Anchor louvers to the building substructure in accordance with manufacturer's instructions.
- E. Do not erect warped, bowed, deformed or otherwise damaged or defaced louver components.
- F. Set units level, plumb and true to line, with uniform joints.
- G. Seal louver assemblies to abutting construction per Section 07 92 13.

3.03 CLEANING

- A. Clean in accordance with Section 01 70 00.

END OF SECTION

THIS PAGE INTENTIONALLY LEFT BLANK

SECTION 09 21 16

STEEL FRAMED DRYWALL SYSTEMS

PART 1 - GENERAL

- 1.1 SCOPE: Provide all necessary materials for construction of drywall systems.
- 1.2 RELATED SECTIONS:
- A. Division 06 Carpentry Section for wood framing, blocking and furring.
 - B. Division 09 Painting Section for paint applied to gypsum board surfaces.
 - C. Section 05 50 00 - Miscellaneous Metal Work
- 1.3 DELIVERY AND STORAGE OF MATERIALS:
- A. Deliver, store, and handle under provision of Section 01 60 00.
 - B. All materials shall be delivered in their original unopened packages and stored in an enclosed shelter providing protection from damage and exposure to the elements. Damaged or deteriorated materials shall be removed from the premises. Stack gypsum panels flat to prevent sagging.
- 1.4 ENVIRONMENTAL CONDITIONS:
- A. In cold weather and during gypsum panel joint finishing, temperatures within the building shall be maintained within the range of 55 degrees to 70 degrees F. Adequate ventilation shall be provided to carry off excess moisture.
 - A. Do not install panels that are wet, those that are moisture damaged, and those that are mold damaged.
- 1.5 SUBMITTALS
- A. Submit under provisions of Section 01 33 00.
 - B. Product Data: Submit product data on all materials and accessories.

PART 2 - PRODUCTS MANUFACTURERS

- A. Provide manufacturer and product specified under the Materials paragraph below.
- B. Substitutions: Under provisions of Section 01 60 00.

2.2 MATERIALS: See drawings for size and location of materials.

- A. Non-Structural Studs: Cold-formed galvanized steel C-studs as per ASTM C 645, ProSTUD products manufactured by ClarkDietrich Building Systems.
 - 1. Unless noted otherwise on the drawings, provide the following: Minimum 25 gage for interior non-load bearing partitions, maximum 10'-0" high and 20 gage for above 10'. Provide 20 gage for interior load bearing partitions. Provide 20 gage for jamb and lintel components.
 - 2. Flange Size: 1 1/4 inch.
 - 3. Web Depth: As specified on Drawings.
- B. Non-Structural Track: Cold-formed galvanized steel runner tracks, drywall track, in conformance with ASTM C 645, ProTRAK as manufactured by ClarkDietrich Building Systems.
 - 1. Flange Size: 1-1/4 inch
 - 2. Web Depth: Track web to match and coordinate with stud web size.
- C. Metal Furring (Hat) Channel manufactured by ClarkDietrich Building Systems: 7/8" depth by 10' or 12' length, (20 gauge at ceilings) (25 gauge at walls), meet or exceed ASTM C645.
- D. Z Furring Channel manufactured by ClarkDietrich Building Systems available in 1", 1-1/2", 2", 2 1/2" depths by 10' length with 1 1/4" wide flange, meet or exceed ASTM C645. See drawings for size and gage.
- E. Provide 1-1/2" Cold-Rolled Channels.
- F. Galvanized Hanger Wire (12-ga)
- G. 18-ga. Galvanized Tie Wire.
- H. Faceboards - 48" wide USG Sheetrock Brand Firecode Type X gypsum board
Provide lengths as required.
Thickness to be as indicated on drawings. If not indicated on drawings, board to be 5/8" thick.
- I. Fasteners - USG Screws: 3/8" Type S, pan head; 3/8", 1/2" Type S-12, pan head; 5/8" Type S-12 low-profile head; 1", 1-1/4", 1-5/8", 1-7/8", 2-1/4" Type S, bugle head; 1", 1-5/8", 2-1/4" Type S or S-12, trim head; 1-1/2" Type G, bugle head; 1-1/4" Type W, bugle head; 1`-1/4" annular ring drywall nail.
- J. USG Trim No. (200-A)(401)(402)(P-1)(801-A)(801-B).
- K. USG Corner Bead - (No. 103 DUR-A-BEAD) (No. 104 DUR-A-BEAD)(No.800) Metal Corner Reinforcement.
- L. USG Control Joint No. 093
- M. Joint Treatment (select a United States Gypsum Company Joint System)
Standard Gypsum Finish = Joint Treatment: Sheetrock Brand All Purpose Joint Compound.
Provide a Level 4 gypsum board finish. (Coat gypsum only at joints and fasteners)
This finish is to be used typically everywhere except where otherwise noted on the drawings.

- N. USG Acoustical Sealant
- O. Shaftwall
 - 1. Assembly consisting of:
 - a. CH Studs and "J" Tracks
 - b. Liner panels: Gypsum panels; 1 in. thick x 24 in. wide x lengths as required; beveled edges, water resistant green face glass-mat; with UL Classification Label affixed; exceed ASTM C1658; SHEETROCK Brand Glass-Mat Liner Panels
 - c. Faceboards: Firecode Type X Gypsum Panels as noted above.
 - 1. Two Hour Rated: two layers 1/2" board
 - B. One Hour Rated: one layer 5/8" board
- P. Adhesive
 - (for double-layer applications and column fireproofing) Durabond joint Compound or USG Ready-Mixed Joint Compound (All Purpose) (Taping)
 - (for adhesive application) Drywall Stud Adhesive.

PART 3 - EXECUTION

3.1 PARTITION INSTALLATION

- A. **STUD SYSTEM ERECTION:** Attach steel runners at floor and ceiling to structural elements with suitable fasteners located 2" from each end and spaced 24" o.c.
To suspended ceilings, use toggle bolts or hollow wall anchors spaced 16" o.c.

Position studs vertically, with open side facing in same direction, engaging floor and ceiling runners, and spaced 16" o.c. When necessary, splice studs with 8" nested lap and two positive attachments per stud flange. Place studs in direct contact with all door frame jambs, abutting partitions, partition corners and existing construction elements. Where studs are installed directly against exterior walls and a possibility of water penetration through walls exists, install asphalt felt strips between studs and wall surfaces.

Anchor all studs for shelf-walls and those adjacent to door and window frames, partition intersections, corners and freestanding furring to ceiling and floor runner flanges with USG Metal Lock Fastener tool or screws. Securely anchor studs to jamb and head anchors of door or borrowed light frames by bolt or screw attachment. Over metal door and borrowed light frames, place horizontally a cut to length section of runner, with a web flange bend at each end, and secure to strut-studs with two screws in each bent web. Position a cut-to-length stud (extending to ceiling runner) at vertical panel joints over door frame header. When attaching studs to steel grid system, structural adequacy of grid to support end reaction of wall must be determined.

All steel stud partitions are to extend from floor to underside of roof or floor deck above. If noted on drawings that partition only extends a certain distance above the ceiling and not to the underside of the deck, the top of the partition is to be braced with 3 5/8 inch, 25 gage steel studs set at a 45 degree angle at 48 inches on center with every-other brace installed in the opposite direction. Verify method of brace attachment to partition and deck with Architect prior to installation.
- B. As occurring:
Install Sound Attenuation Insulation after gypsum panels are applied to the resilient channel (if occurring) and before panels are applied to other side of studs. Insert the sound insulation in the stud cavity, by bowing the blanket slightly. After inserting, make a vertical cut between the studs.

Slit the blanket with a sharp utility or hook-bill knife to ease the pressure of the blanket against the gypsum panels when they are installed. Butt ends of blankets closely together and fill all voids. Seal perimeter of gypsum board and all penetrations with acoustical sealant to complete the requirements for a sound retardant partition.

3.2 APPLYING INTERIOR GYPSUM BOARD

A. Single-Layer Application:

1. On ceilings, apply gypsum panels before wall/partition board application to greatest extent possible and at right angles to framing, unless otherwise indicated.
2. On partitions/walls, apply gypsum panels vertically (parallel to framing), unless otherwise indicated or required by fire-resistance-rated assembly, and minimize end joints.
 - a. Stagger abutting end joints not less than one framing member in alternate courses of panels.
 - b. At stairwells and other high walls, install panels horizontally, unless otherwise indicated or required by fire-resistance-rated assembly.
3. On Z-furring members, apply gypsum panels vertically (parallel to framing) with no end joints. Locate edge joints over furring members.
4. Fastening Methods: Apply gypsum panels to supports with steel drill screws.

B. Multilayer Application:

1. On partitions/walls, apply gypsum board indicated for base layers and face layers vertically (parallel to framing) with joints of base layers located over stud or furring member and face-layer joints offset at least one stud or furring member with base-layer joints, unless otherwise indicated or required by fire-resistance-rated assembly. Stagger joints on opposite sides of partitions.
2. On ceilings, apply gypsum board indicated for base layers before applying face layers on walls/partitions; apply face layers in same sequence. Apply base layers at right angles to framing members and offset face-layer joints 1 framing member, 16 inches minimum, from parallel base-layer joints, unless otherwise indicated or required by fire-resistance-rated assembly.

C. Gypsum Panel Attachment

Screw spacing that follows is for non-rated construction. For fire-rated construction, obtain screw spacing from manufacturer's fire test report.

For single-layer panel application, space screws 16" o.c. in field and along abutting end joints.

For double-layer screw attachment, space screws 24" o.c. in base layer and 16" o.c. in face layer. Apply both layers of gypsum panels vertically with joints in face layer offset from base layer joints by at least one stud. On tall walls, offset end joints also. For 1/2" and 5/8" panels, use 1" screws for base layer and 1-5/8" screws for face layer.

For resilient construction, apply gypsum panels with long dimension perpendicular to resilient channels and fasten with 1" Type S Screws spaced 12" o.c. along channels. Where channel resiliency makes screw placement difficult, the next longer screw may be used but do not drive screw directly over stud.

3.3 DRYWALL SOFFIT ERECTION:

- A. Attach steel runners 24" o.c. to concrete slabs and concrete stub nails or power-driven anchors, to suspended ceilings with toggle bolts or to wood framing with suitable fasteners. On stud walls, space fasteners to engage each stud. On ceilings, place fastener close to outside face runner.
- B. Fasten vertical face panel to web of face corner runner and flange of ceiling runner with 1" Type S Screws spaced 12" o.c. For braced furring, insert steel studs between face corner runners, sidewall and ceiling runners and attach studs to runners with Metal Lock Fastener tool or 3/8" pan head screws. Attach face panels to steel studs and runners with 1" Type S Screws spaced 12" o.c. Space screws in corner runner at least 1" from gypsum panel edge.

3.4 CEILING INSTALLATION

- A. GRILLAGE ERECTION: Space 9 ga. hanger wires 48" o.c. along carrying channels and within 6" of ends of carrying channel run. In concrete, anchor hangers by attachment to reinforcing steel, by loops embedded at least 2" or by approved inserts. For steel construction, wrap hanger around or through beams or joists.

Install 1-1/2" carrying channels 48" o.c. and within 6" of walls. Position channels for proper ceiling height, level, and secure with hanger wire saddle-tied along channel. Provide 1" clearance between runners and abutting walls and partitions. At channel splices, interlock flanges, overlap ends 12" and secure each end with double strand 18 ga. tie wire.

Erect metal furring channels at right angles to 1-1/2" carrying channels or main supports. Space furring 16" o.c. and within 6" of walls. Provide 1" clearance between furring ends and abutting walls and partitions. Secure furring to carrying channels with clips or wire tie to supports with double strand 18 ga. wire. At splices, nest furring channels at least 8" and securely wire-tie each with double strand 18 ga. wire.

At light troffers or any openings that interrupt the carrying or furring channels, install additional cross reinforcing to restore lateral stability of grillage.

- B. STEEL STUD FRAMING SYSTEM ERECTION: Attach runners at ceiling height, through gypsum panels, to each partition stud with two screws. Insert steel studs in runners and attach each end with one 3/8" pan head screw. Install 1-5/8" stud cross bracing over stud framing, space 48" o.c. and attach to each framing stud with two 3/8" pan head screws. At hangers, install 12" long stud section for box reinforcing or lap studs 12" and secure each end with two 3/8" pan head screws.

At light troffers or any openings that interrupt the ceiling, install additional cross reinforcing to maintain structural integrity of framing.

- C. GYPSUM PANEL ERECTION: Apply gypsum panels of maximum practical length with long dimension perpendicular to furring channels. Position end joints over channel web and stagger in adjacent rows.
Fit ends and edges closely, but not forced together. Fasten panels to channels with 1" Type S Screws spaced 12" o.c. in field of panels and along abutting ends and edges.

- D. Contractor is to cut all openings in gypsum board ceiling as required to install recessed lighting and any other recessed electrical fixtures or miscellaneous equipment. Coordinate with the associated MEP contract documents.
Provide additional miscellaneous metal framing and support cables/struts as necessary to support all recessed light fixtures if required by light fixture manufacturer. Coordinate with electrical contract documents.
See Specification Section 05 50 00 - Miscellaneous Metal Work for additional information.

3.5 WALL FURRING INSTALLATION

- A. METAL FURRING (HAT) CHANNEL INSTALLATION: Attach metal furring channels horizontally, spaced 24" o.c. to interior of masonry or concrete surface with hammer set or power driven fasteners or concrete stub nails staggered 24" o.c. on opposite flanges. Where furring channel is installed directly to exterior wall and a possibility of water penetration through walls exists, install asphalt felt protection strip between furring channel and wall.

Apply gypsum panels parallel to channel. Position all edges over furring channels in parallel application; all ends over framing in perpendicular application with joints staggered in successive courses. Use maximum practical lengths to minimize end joints. Fit ends and edges closely, but not forced together. Fasten panels to channels with 1" Type S Screws spaced 16" o.c.

- B. Z FURRING CHANNEL INSTALLATION: Erect insulation vertically and hold in place with Z-furring channels spaced 24" o.c. Except at exterior corners, attach narrow flanges of furring channels to wall with concrete stub nails or power driven fasteners spaced 24" o.c. At exterior corners, attach wide flange of furring channel to wall with short flange extending beyond corner. On adjacent wall surface, screw attach short flange of furring channel to web of attached channel. Start from this furring channel with a standard width insulation panel and continue to regular manner. At interior corners, space second channel no more than 12" from corner and cut insulation to fit. Hold mineral fiber insulation in place until gypsum panels are installed with 10" long staple field fabricated from 18 ga. tie wire and inserted through slot in channel. Apply wood blocking around window and door opening and as required for attachment of fixtures and furnishings.

Apply gypsum panels parallel to channels with vertical joints occurring over channels. Use no end joints in single-layer application. Attach gypsum panels with 1" Type S Screws spaced 16" oc. in field of panels and at edges, and with 1-1/4" Type S Screws spaced 12" o.c. at exterior corners. For double-layer application, apply base layer parallel to channels, face layer either perpendicular or parallel to channels with vertical joints offset at least one channel. Attach base layer with screws 24" o.c. and face layer with 1-5/8" screws 16" o.c.

3.6 CHASE WALL ERECTION

- A. Align two parallel rows of floor and ceiling runners spaced apart as detailed. Attach to concrete slabs with concrete stub nails or power-driven anchors 24" o.c. to suspended ceilings with toggle bolts 16" o.c. or to wood framing with suitable fasteners 24" o.c.
- B. Position steel studs vertically in runners, 24" o.c. with flanges in the same direction, and with studs on opposite sides of chase directly across from each other. Anchor all studs to floor and ceiling runner flanges with a Metal Lock Fastener tool or screws.

- C. Cut cross bracing made from gypsum panels, 12" high by chase wall width. Place between rows of studs. Space braces 48" o.c. vertically and attach to stud webs with six 1" Type S Screws per brace. If larger braces are used, space screws 8" o.c. max. on each side.
- D. Bracing of 2-1/2" steel studs may be used in place of gypsum panels. Anchor web at each end of at each end of steel brace to stud web with two 3/8" pan head screws. When chase wall studs are not opposite, install steel stud cross braces 24" o.c. horizontally and securely anchor each end to a continuous horizontal 2-1/2" runner screw attached to chase wall studs within the cavity.

3.7 SHAFT WALL INSTALLATION

- A. Position steel J-runners at floor and ceiling with the short leg toward finish side of wall.
- B. Securely attach runners to structural supports with power-actuated fasteners at both ends and max. 24" o.c.
- C. For attachment to steel frame construction, install floor and ceiling J-runners and J-runners or E-studs on columns and beams.
- D. For attachment to structural steel, use Z-shaped stand-off clips secured to structural steel.
- E. If necessary, remove spray-fireproofing from J-runners and E-studs before installing gypsum liner panels.
- F. For wall heights less than maximum available panel height, cut gypsum liner panels no more than 1" less than floor-to-ceiling height and erect vertically between J-runners.
- G. Where shaft wall height shaft exceeds maximum available panel-length, pieces of gypsum liner panel must be butted together at factory-cut ends.
 - 1. Position gypsum liner panel end joints within upper and lower third points of wall.
 - 2. Stagger joints top and bottom in adjacent panels.
 - 3. Screw studs to runners on walls over 16'.
- H. Cut C-H studs 3/8" to not more than 1/2" less than floor-to-ceiling height.
- I. Install C-H studs between gypsum liner panels with liner securely engaged.
- J. Terminations: Install full-length steel E-studs or J-runners vertically at T-intersections, corners, door jambs and columns.
- K. Openings: Frame with vertical E-stud or J-runner at vertical edges, horizontal J-runner at head and sill. Reinforce as shown in this brochure. Suitably frame all openings to maintain structural support for wall.
- L. Elevator Door Frames as occurring: Install jamb struts each side of elevator door frames to act as strut-studs.
- M. Steel Hinged Door Frames as occurring: Install floor-to-ceiling steel E-studs each side to act as strut-studs.
- N. Attach strut-stud to floor and ceiling runners with two 3/8" Type S-12 pan head screws. Attach strut-studs to jamb anchors with 1/2" Type S-12 screws. Over steel doors, install a cut-to-length section of J-Runner and attach to strut-studs with 3/8" Type S-12 screws.
- O. Install gypsum panels and fasteners per the corresponding fire-resistance design number that is the basis of design.
- P. USG Shaft Wall Systems
 - 1. Sheetrock gypsum panels may be applied vertically or horizontally in all of the systems below, except System F. Please note appropriate fastener spacing.

System A—U415 or U469, one-hour fire-resistance rating.

Apply one layer 5/8" Sheetrock Firecode Core gypsum panels to C-H studs and runners with 1" Type S or S-12 (typical) screws. Space screws 12" o.c. for vertical panel application, 8" o.c. for horizontal panel application.

System B—U415 System B or U438, two-hour fire-resistance rating.

Apply two layers of 1/2" Sheetrock Firecode Core gypsum panels. Apply base layer to C-H studs with 1" Type S or S-12 (typical) screws. Space screws 24" o.c. along edges and in the field of the panels for vertical application, 16" o.c. for horizontal application. Apply face layer to C-H studs and J-runners with 1-5/8" Type S or S-12 (typical) screws. Space screws 12" along the edges and in the field when applied vertically, 8" o.c. when applied horizontally. Stagger all joints between base and face layers.

3.8 ACCESSORY APPLICATION

- A. JOINT SYSTEM: Finish all face panel joints and internal angles with a United States Gypsum Company Joint System installed according to manufacturer's directions. Spot exposed fastened on face layers and finish corner bead, control joints and trim as required, with at least three coats of joint compound, feathered out onto panel faces and sanded smooth.
- B. CORNER BEAD: Reinforce all vertical and horizontal exterior corners with corner bead fastened with 9/16" galvanized staples 9" o.c on both flanges along entire length of bead.
- C. METAL TRIM: Where assembly terminates against masonry or other dissimilar material, apply metal trim over panel edge and fasten with 9/16" galvanized staples 9" o.c.
- D. SCREWS: Power drive at least 3/8" from edges or ends of panel to provide uniform dimple 1/32" deep.
- E. CONTROL JOINTS: Break panel behind joint and back by double framing embers (and 2" wide gypsum panel strip). Apply acoustical sealant to fill gap and attach control joint to face layer with 9/16" galvanized staples spaced 6" o.c. on both flanges along entire length of joint. Provide a full height control joint where a wall or partition extends in a continuous straight plane for more than 30 linear feet or where indicated on the drawings.

3.9 ASSOCIATED METAL FRAMING

- A. Provide metal framing as required to support light fixtures, piping, HVAC equipment and ductwork below gypsum board ceilings or as required to span across/over/under suspended equipment. Coordinate with the associated MEP contract documents. See Section 05 50 00 - Miscellaneous Metal Work for additional information.

3.10 CLEANING

- A. Clean project under provisions of Section 01 70 00.

END OF SECTION

SECTION 09 28 13

CEMENTITIOUS BACKER BOARD

PART 1 - GENERAL

1.01 SECTION INCLUDES

- A. All necessary materials and labor to install cementitious backer board.

1.02 SUBMITTALS

- A. Submit product data under provisions of Section 01 33 00.

1.03 QUALIFICATIONS

- A. Installer: Company specializing in performing the work of this section with minimum three years experience.

1.04 DELIVERY, STORAGE, AND HANDLING

- A. Deliver, store, protect and handle products to site under provisions of Section 01600.
- B. Store products in an enclosed shelter providing protection from damage and exposure to the elements.

1.05 ENVIRONMENTAL REQUIREMENTS

- A. In cold weather and during backer board and tile installation, temperatures within the building shall be maintained within the range of 45° to 100°. Adequate ventilation shall be provided. Do not install board when it is wet.

PART 2 - PRODUCTS

2.01 MANUFACTURER

- A. United States Gypsum Board
- B. Substitutions: Under provisions of Section 01 60 00.

2.02 MATERIALS

- A. Cement Board
 - 1. Durock Interior Cement Board, 5/8" thickness, 48" width x 96" length.
- B. Joint Reinforcement - Durock Interior Tape.

- C. Fasteners
 - 1. Durock Steel Screws, 1-1/4" and 1-5/8" for 14 to 20 ga. steel framing; Durock Wood Screws, 1-1/4", 1-5/8" and 2-1/4" for wood framing.
 - 2. Nails 1-1/2" hot-dipped galvanized roofing nails.

- D. Adhesives/mortars
 - 1. Meeting ASTM C557-73: Multi-Purpose Adhesive (for subfloor attachment).
 - 2. Meeting ANSI A136.1 Type I: Durabond D-67 Multi-Purpose Ceramic Tile Mastic or Durock or Durabond Multi-Purpose Ceramic Tile Mastic.
 - 3. Meeting ANSI A118.4: Durabond D-40 or Durock Latex Fortified Mortar, Durabond D-30 Thin-Cut Marble and Granite Mortar.
 - 4. Meeting ANSI A118.1: Durabond D-50 Thin-Set Mortar. Can be mixed with Durabond D-L16 Acrylic Latex Additive.

- E. Meeting ANSI A118.6: Durock LFG 250 Latex Fortified Grout; Durabond C-150 Commercial Dri-Set Grout mixed with Durabond D-L26 Acrylic Latex Grout Additive.

PART 3 - EXECUTION

3.01 EXAMINATION

- A. Framing to receive Durock Board shall be structurally sound, free from bow, and in general compliance with local building code requirements. Damaged and excessively bowed studs shall be replaced before installation of Durock Board.
Wall framing shall be designed not to exceed L/360 deflection. Steel framing must be 20-ga. or heavier with a corrosion-resistant metal coating equivalent to G60 hot dipped galvanized.
Floor application: Maximum joist spacing to be 24" o.c. The subfloor system should be designed with a minimum deflection limit of L/360 for the span.

3.02 INSTALLATION

- A. Install in accordance with manufacturer's instructions and recommendations.
- B. Space wood and steel framing a maximum of 16" o.c.
- C. NOTE: Provide and install cementitious backer board as back-up behind all areas where ceramic tile, stone wall base and DWP are scheduled and in any additional areas noted on the drawings or in the specifications.
- D. Panel Wall Application: Pre-cut board to required sizes and make necessary cut-outs. Fit ends and edges closely but not forced together. Stagger end joints in successive courses.
Fasten boards to wood studs spaced max. 16" o.c. and bottom plates with 1-1/4" Durock Wood Screws or 1-1/2" galvanized roofing nails spaced 8" o.c.
Fasten boards to steel studs spaced max. 16" o.c. and bottom runners with 1-1/4" Durock Steel Screws space 8" o.c. with perimeter fasteners at least 3/8" and less than 5/8" from ends and edges.

In double-layer walls where backer boards are installed over base-layer gypsum boards, apply a water barrier (not a vapor retarder) over gypsum boards. Prefill joints with tile-setting mortar or

adhesive and then immediately embed tape and level the joints. As an alternate, apply Durock Interior Tape over the joints and then apply tile-setting mortar or adhesive, forcing it through the tape to completely fill and level the joints. This may require several passes to accomplish.

3.03 JOINT TREATMENT APPLICATION FOR UNTILED AREA

- A. For small areas where the Durock Board will not be tiled, such as a board extending beyond the tiled area and abutting another surface, treat joints as follows. Seal tile backer board with thinned ceramic tile mastic. (Mix four parts adhesive with one part water.) Embed Sheetrock Joint Tape over joints and treat fasteners with Sheetrock Setting-Type 45 or 90 Joint Compound applied in conventional manner. Flat trowel Sheetrock Setting-Type Joint Compound over board to cover fasteners and fill voids to a smooth surface. Finish joints with at least two coats Sheetrock Ready-Mixed Joint Compound. Do not apply ready-mixed joint compound over unsealed board.

3.04 CLEANING

- A. Clean work under provisions of Section 01 70 00.

END OF SECTION

THIS PAGE INTENTIONALLY LEFT BLANK

SECTION 09 30 13

CERAMIC TILE

PART 1 - GENERAL

1.01 SECTION INCLUDES

- A. Ceramic tile application where indicated.

1.02 REFERENCES

- A. ANSI/TCA A118.4 - Latex-Portland Cement Mortar.
- B. ANSI/TCA A136.1 - Organic Adhesives for Installation of Ceramic Tile, Type 1 and Type 2.
- C. ANSI/TCA A137.1 - Specifications for Ceramic Tile.
- D. ASTM C-150, Type 1 - Portland Cement Mortar
- E. TCA (Tile Council of America) - handbook for Ceramic Tile Installation.

1.03 SUBMITTALS

- A. Submit product data for ceramic tile under provisions of Section 01 33 00.
- B. Submit product data indicating material specifications, characteristics, and instructions for using adhesives and grouts.
- C. Submit samples for ceramic tile under provisions of Section 01 33 00.
- D. Sustainable Design Submittal:
 - 1. Provide documentation indicating percentages of post-consumer and pre-consumer recycled content.
 - 2. Identify each regional material along with the location of its harvest, extraction, or manufacture.

1.04 QUALITY ASSURANCE

- A. Conform to TCA Handbook for Ceramic Tile Installation.

1.05 DELIVERY, STORAGE, AND HANDLING

- A. Deliver, store and protect products under provisions of Section 01 60 00.
- B. Protect adhesives from freezing or overheating in accordance with manufacturer's instructions.

1.06 ENVIRONMENTAL REQUIREMENTS

- A. Do not install adhesives in a closed, unventilated environment.
- B. Maintain 50 degrees F during installation of mortar materials and for 7 days after completion.
- C. All materials are to be low VOC.

1.07 MAINTENANCE DATA

- A. Submit maintenance data on all materials under the provisions of Section 01 78 00.
- B. Submit data including cleaning methods, solutions recommended, and stain removal methods.

1.08 WARRANTY

- A. Provide five year warranty under provisions of Section 01 78 00.
- B. Warranty: Include coverage for defective material.

1.09 EXTRA MATERIALS

- A. Furnish under provisions of Section 01 78 00.
- B. Supply minimum 2% of each type tile and color used, properly packaged for long term storage.

PART 2 - PRODUCTS

2.01 MANUFACTURERS

- A. Basis of Design: Crossville
- B. Other Acceptable Manufacturers
 - 1. American Olean
 - 2. Florida Tile
 - 3. Dal-Tile
- C. Substitutions: Under provisions of Section 01 60 00.

2.02 MATERIALS

- A. Wall tile: Crossville
Tile Style: Cursive
 - Listed on drawings as CT1, CT2, CT3 and CT4
 - Sizes and shapes as shown on drawings in standard manufacturer sizes and shapes.
 - Colors selected by Architect from standard colors. See Material, Color and Finish Schedule on drawings.
 - Gloss finish.
 - Provide all necessary trim and accessories as required including cove base.

- B. Floor Tile: Crossville
Tile Style: Basalt Porcelain Stone
- Listed on drawings as PORT1, PORT2 and PORT3.
 - Sizes as shown on drawings in standard manufacturer sizes.
 - Colors selected by Architect from standard colors. See Material, Color and Finish Schedule on drawings.
 - Cross-Sheen finish.
 - Grout joint size: 3/16"
 - Provide all necessary trim and accessories as required including cove base.
- C. Base: Crossville
Tile Style: Basalt Porcelain Stone (coordinate with floor tile)
- Listed on drawings as B2
 - Base tile is to be coved with a flat top.
 - Size: 6" x 12"
 - Provide Schluter Rondec aluminum bullnose to finish off top of base.
- D. Base: Crossville
Tile Style: Cove base (universal, flat top)
- Listed on drawings as B4
 - Coordinate with CT1, CT2, CT3 and CT4 wall tile.
 - Wall base tile is to be coved with a flat top.
 - Size: 6" x 12"
 - Gloss finish.
- E. Grout: Latex-Portland Cement grout conforming to ANSI A118.6. Color to be selected by Architect. Manufacturer: Laticrete Spectralock Pro or equal.
- F. Top of Base – Aluminum trim
1. Manufacturer: Schluter Systems (or equal)
 2. Model: RONDEC
 - a. Description: bullnose-type profile with symmetrically rounded visible surface with 1/4" (6 mm) radius, integrated trapezoid-perforated anchoring leg, and integrated grout joint spacer.
 - b. Material and Finish: Satin Anodized Aluminum – color selected from manufacturer's standard colors.
 - c. Size as required to coordinate with top of porcelain stone base B2.

PART 3 - INSTALLATION

3.01 EXAMINATION

- A. Verify that surfaces are ready to receive work, and that substrate has cured a minimum of 28 days.
- B. Beginning of installation means installer accepts condition of existing substrate.

3.02 PREPARATION

- A. Protect surrounding work from damage or disfiguration.
- B. Vacuum clean existing substrate and damp clean.
- C. Seal substrate surface cracks with filler. Level existing substrate surfaces to acceptable flatness tolerances.

3.03 INSTALLATION

A. THINSET METHOD

- 1. Floors: Tile shall be installed in accordance with TCA-F113 latex portland cement mortar.
- 2. Walls - All wall tile installed over cementitious backer board is to be installed in accordance with TCA-W244 latex portland cement mortar.
- 3. Walls - All wall tile installed over masonry is to be installed in accordance with TCA-W202 with latex portland cement mortar.

- B. Apply clear, elastomeric, mildew-resistant silicone rubber caulking to junction of tile and dissimilar materials and at junction of dissimilar planes.

3.04 APPLICATION

- A. Lay tile to pattern as indicated on drawings.
- B. Cut and fit tile tight to penetrations through tile. Form corners and bases neatly. Align floor and base joints.
- C. Coved base wall tile (if specified) is to be installed so top of curved bottom portion is level with surface of tile floor.
- D. Place tile joints uniform in width, subject to variance in tolerance allowed in tile size. Make joints watertight, without voids, cracks, excess mortar, or excess grout.
- E. Sound tile after setting. Replace hollow sounding units.
- F. Keep control joints free of adhesive or grout.
- G. Allow tile to set for a minimum of 48 hours prior to grouting.
- H. Grout tile joints. Grout width to be the minimum required by the tile manufacturer unless noted otherwise.
- I. Wall tile and base must be installed on only cementitious backer board, concrete or masonry.
- J. Apply sealant to junction of tile and dissimilar materials and at junction of dissimilar planes.

3.05 CLEANING

- A. Upon completion of the various portions of his work, the tile contractor shall remove all unused materials, rubbish, etc., that have accumulated as a result of this work.
- B. After the pointing has sufficiently set or hardened, all tile on walls and vertical surfaces, or floors and horizontal surfaces, shall be thoroughly cleaned in an approved manner. All traces of cement or dust accumulations shall be completely removed. In cases where acid solutions are required to clean the face of the finished tile work of surplus grouting or mortar used for pointing, all exposed hardware shall be first covered by a heavy coating of vaseline to protect the metal from the possible effects of the acid or its fumes. Acid solution shall not be used for cleaning glazed tile.
- C. The Tile Contractor shall give the tile work one thorough final cleaning when so instructed by the General Contractor or Architect.

3.06 PROTECTION OF FINISHED WORK

- A. Protect finished work under provisions of Section 01 70 00.
- B. Protect finished floor with heavy covering during construction.
- C. Do not permit traffic on floor for a minimum of 7 days after grouting.

END OF SECTION

THIS PAGE INTENTIONALLY LEFT BLANK

SECTION 09 30 16

QUARRY TILE

PART 1 - GENERAL

1.01 SUMMARY

- A. Section Includes: Provision and installation of unglazed quarry tile, base and trim units.
- B. Listed on drawings as "QT-1".

1.02 REFERENCES

- A. American National Standards Institute (ANSI):
 - 1. ANSI A108 Series - Specifications for Installation of Ceramic Tile and Dimensional Tile.
 - 2. ANSI A 108. 1 A - Specifications for Installation of Ceramic Tile in the Wet Set Method.
 - 3. ANSI A 108. 10 - Load Bearing, Bonded, Waterproof Membranes for ThinSet Ceramic Tile and Dimensional Tile
 - 4. ANSI A 118 Series - Specifications for Ceramic Tile Mortars and Grouts.
 - 5. ANSI A 136.1 Organic Adhesives for Installation of Ceramic Tile,
 - 6. ANSI A 137.1 Specifications for Ceramic Tile.
- B. American Society for Testing and Materials (ASTM):
 - 1. ASTM C499 Facial Dimensions and Thickness of Flat, Rectangular Ceramic Wall And Floor Tile.
 - 2. ASTM C501 Relative Resistance to Wear of Unglazed Ceramic Tile by the Taber Abraser
 - 3. ASTM C 1028 Test Method for Determining the Static Coefficient of Friction of Ceramic Tile and Other Tile Like Surfaces by the Horizontal Dynamometer Pull Meter Method.

1.03 SUBMITTALS

- A. Submit under provisions of Section 01 33 00.
- B. Product Data: Submit product data, including manufacturer's product sheet, for specified products,
- C. Samples: Submit selection and verification samples for finishes, colors and textures,
- D. Quality Assurance Submittals: Submit the following:
 - 1. Test Reports: Certified test reports showing compliance with specified performance characteristics and physical properties.
 - 2. Certificates: Product certificates signed by manufacturer certifying materials comply with specified performance characteristics and physical requirements.
 - 3. Master Grade Certificate: Submit material master grade certification for quarry tile products.
 - 4. Manufacturer's Instructions: Manufacturer's installation instructions.
- E. Closeout Submittals: Submit the following:
 - 1. Maintenance Data: Maintenance data for installed products in accordance with Division 1 Closeout Submittals, Maintenance Data and Operation Data Section, Include methods for

maintaining installed products and precautions against cleaning materials and methods detrimental to finishes and performance.

2. Warranty: Warranty documents specified herein.

1.04 QUALITY ASSURANCE

- A. Installer Qualifications: Installer experienced in performing work of this section who has specialized in the installation of work similar to that required for this project and who is acceptable to product manufacturer.
- B. Material Certificates: Provide Master Grade Certificates for each shipment of quarry tile signed by tile manufacturer and Installer.
- C. Pre Installation Meetings: Conduct pre-installation meeting to verify project requirements, substrate conditions, manufacturer's installation instructions and manufacturer's warranty requirements, Comply with Division 1 Project Management and Coordination, Project Meetings Section.

1.05 DELIVERY, STORAGE, AND HANDLING

- A. Deliver, store, protect and handle products to site under provisions of Section 01 60 00.
- B. Ordering; Comply with manufacturer's ordering instructions and lead time requirements to avoid construction delays.
- C. Delivery: Deliver materials in manufacturer's original, unopened, undamaged containers with identification labels intact. Comply with ANSI A137.1 for labeling sealed tile containers.
- D. Storage and Protection: Store materials protected from exposure to harmful weather conditions and at temperature conditions recommended by manufacturer.

1.06 PROJECT CONDITIONS

- A. Temperature Requirements: Maintain ambient temperature and humidity conditions in spaces where products will be installed for time period before, during and after installation as recommended by manufacturer.
 1. Minimum Temperature: Maintain temperature at 50°F minimum during installation and for seven days after completion.

1.07 WARRANTY

- A. Project Warranty: Refer to Conditions of the Contract for project warranty provisions.
- B. Manufacturer's Warranty; Submit the manufacturer's standard warranty document under the provisions of Section 01 78 00. Provide a minimum one year warranty.

1.08 MAINTENANCE

- A. Extra Materials: Deliver to Owner extra materials from same production run as products installed, Package products with protective covering and identify with descriptive labels. Comply with Division I Closeout Submittals, Maintenance Materials Section.
1. Quantity: Furnish quantity of full size units equal to minimum 2% of amount installed for tile and trim units.
 2. Delivery, Storage and Protection: Comply with Owner's requirements for delivery, storage and protection of extra materials.

PART 2 - PRODUCTS

2.01 MANUFACTURERS

- A. Manufacturer: Metropolitan Ceramics, by Ironrock Capital, Inc.
1. Contact: P.O. Box 9240, Canton, OH 44711; Telephone: (800) 325-3945, (330) 484-4887; Fax: (330) 484-4880.
 2. Substitutions under provisions of Section 01 60 00.

2.02 PRODUCTS

- A. Quarry tile
1. Quarrybasics® Quarry Tile:
 - a. Tile Description: Unglazed, relieved edge flat tile.
 - b. Size: 6" x 6" x 1/2"
 - c. Wearing Surface: (ASTM C501 Abrasion resistance index 35 or better.) (Metropolitan tests at > 80 or better).
 - d. Coefficient of Friction (ASTM C1028): No industry standard. At time of manufacture, all Metropolitan colors meet or exceed measure of 0.70 dry and 0.60 wet.
 - e. Face size tolerance (ASTM C499) Average facial dimension of each tile in the sample shall not vary more than 4% of nominal dimensions.
 - f. Thickness: 1/2"
 - g. Wall Base to be 6" x 6" round top with cove base. Provide outside corners as required.
 - h. Provide 1/2" to 1/4" transition strips as necessary to provide a transition to thinner flooring materials.
 - i. Colors to be selected by Architect from manufacturer's standard colors.

2.02 RELATED MATERIALS

- A. Reference: Refer to Tile Setting And Accessories Section.
1. Setting Materials: Refer to ANSI A108.1A, ANSI A118 series and ANSI 136.1
 2. Grouting Materials: Refer to ANSI 108.10, ANSI A118 series. Color to be selected by Architect from manufacturer's standard colors.
 3. Accessory Materials: Refer to Tile Setting And Accessories Section
 4. Sealant Materials: Refer to Joint Sealant Section.
 5. Backer Board: Refer to Cementitious Backer Board Section 09 28 13.

2.03 SOURCE QUALITY

- A. Source Quality: Obtain quarry tile and base from a single manufacturer.

PART 3 - EXECUTION

3.01 MANUFACTURER'S INSTRUCTIONS

- A. Compliance: Comply with manufacturer's product data, including product technical bulletins, product catalog installation instructions and product carton instructions.

3.02 EXAMINATION

- A. Site Verification of Conditions: Verify substrate conditions are acceptable for product installation in accordance with manufacturer's instructions.
- B. Beginning of installation means installer accepts condition of existing substrate.

3.03 PREPARATION

- A. Surface Preparation: Prepare substrates to receive quarry tile in accordance with industry installation reference standards and manufacturer's installation instructions. Shot blast substrate if required to remove all adhesives or materials determined to be unsuitable by manufacturer's specifications for installation of the tile.
- B. Protect surrounding work from damage or disfiguration.
- C. Vacuum clean existing substrate and damp clean.
- D. Seal substrate surface cracks with filler. Level existing substrate surfaces to acceptable flatness tolerances.
- E. All surfaces must be clean and free from dust, dirt, oil, grease, paint, wax, sealers, curing compounds, or any other deleterious substances which may reduce or prevent adhesion.

3.04 INSTALLATION

- A. References:
 - 1. ANSI Tile Installation Standard: Comply with ANSI A108 series.
 - 2. TCA Installation Reference: Comply with TCA Handbook for Ceramic Tile Installation.
- B. Field Blending: Mix and blend tile from several cartons to ensure random distribution of shade variations.
- C. Floor Tile Installation:
 - 1. General: Install quarry floor tile and trim in accordance with industry reference standards.
 - 2. Joint Widths: Allow for joints widths in quarry floor tile of 3/8".

- D. Wall Tile Installation
 - 1. General: Install quarry wall tile, base and trim in accordance with industry reference standards.
 - 2. Joint Widths: Allow for joints width in quarry wall tile of 3/8".
- E. Patterns: Install quarry tile in pattern as determined by Architect.

3.05 CLEANING AND PROTECTION

- A. Prohibit traffic from the tiled floors for a minimum of 5 days after completion.
- B. Protect the tile floor with heavy duty, non-staining construction paper, masked in place till end of project.
- C. Cleaning: Remove temporary coverings and protection of adjacent work areas. Repair or replace damaged installed products, Clean installed products in accordance with manufacturer's instructions prior to owner's acceptance. Remove construction debris from project site and legally dispose of debris.

END OF SECTION

THIS PAGE INTENTIONALLY LEFT BLANK

SECTION 09 51 23

ACOUSTICAL CEILING SYSTEMS

PART 1 - GENERAL

1.01 SECTION INCLUDES

- A. The furnishing and installation of acoustical and suspension ceiling systems.

1.02 RELATED SECTIONS

- A. Division 23 - Mechanical
- B. Division 26 - Electrical

1.03 REFERENCES

- A. Federal Specification SS-S-118B acoustical tile and panel properties.
- B. AMA 1-11 - Sound transmission
- C. ASTM C423 - Sound absorption
- D. ASTM C635 - Metal suspension system properties
- E. ASTM C636 - Acoustical ceiling system installation procedures
- F. UL - Underwriters Laboratories, Inc.

1.04 SYSTEM DESCRIPTION

- A. Acoustical material and suspension systems, including all necessary hangers, hanger wires, grillage, splines, and supporting hardware, shall be furnished and installed as required to create a completed ceiling system.

1.05 SUBMITTALS

- A. Submit under provisions of Section 01 33 00.
- B. Product Data: Include manufacturer's specifications of materials and installation instructions.
- C. Samples: Submit two 6" x 12" samples of panels and two of the metal suspension system.
- D. Test reports: Submit data indicating the following ratings:
 - NRC (Noise reduction coefficient)
 - CAC (Ceiling Attenuation Class)
 - Light reflectance.
 - Flame spread
 - Smoke developed

1.06 OPERATION AND MAINTENANCE DATA

- A. Submit under provisions of Section 01 78 00.
- B. Submit cleaning and maintenance data including procedures for stain removal and cleaning.

1.07 QUALITY CONTROL

- A. Work shall be performed in accordance with Section 01 45 00.

1.08 QUALIFICATIONS

- A. Installer: Company specializing in installing suspended acoustical ceilings with minimum of three years documented experience.

1.09 REGULATORY REQUIREMENTS

- A. Conform to the manufacturer's recommendations to achieve the fire resistive ratings as listed by Underwriters Laboratories, Inc. (Class A)
- B. All building areas designated to be fire rated or as required by State and Local Codes and scheduled for a suspended ceiling system shall receive a fire resistant system to meet U.L. requirements.

1.10 DELIVERY, STORAGE, AND HANDLING

- A. Deliver, store, protect and handle products to site under provisions of Section 01 60 00.
- B. Storage shall be in building, closed to the weather with temperatures ranging from 60°F to 85°F at not more than 70% relative humidity.

1.11 ENVIRONMENTAL REQUIREMENTS

- A. Do not install acoustical ceiling system when building. Interior temperature is below 60°F, above 90°F or above 70% relative humidity.
- B. These conditions shall be maintained 24 hours prior to, during and after installation.

1.12 FIELD MEASUREMENTS

- A. Verify that field measurements are as indicated on drawings. Any inconsistencies shall be reported to the architect prior to installation.

1.13 SEQUENCING

- A. Installation of panels may commence only after an inspection of all electrical, mechanical and plumbing work has been completed.

1.14 COORDINATION

- A. Coordinate work under provisions of Section 01 31 00.

1.15 WARRANTY

- A. Provide 10 year warranty for the standard acoustical ceiling system under provisions of Section 01 78 00.

1.16 EXTRA MATERIALS

- A. Furnish under provisions of Section 01 78 00.
- B. Provide minimum of 10 panels or 1% of the total of each type of panel installed. (which ever is greater) The additional panels shall be properly packaged for long term storage.

PART 2 - PRODUCTS

2.01 MANUFACTURERS

- A. Acoustical panels
 - 1. Armstrong
 - 2. Other acceptable manufacturers offering equivalent products.
 - a. USG
- B. Suspension System
 - 1. Armstrong
 - 2. Other acceptable manufacturers offering equivalent products.
 - a. Chicago Metallic Corp.
 - b. USG
- C. Substitutions: Under provisions of Section 01 60 00.

2.02 MATERIALS (as listed on finish schedule)

- A. Acoustical Panels
 - 1. Acoustical ceiling tile
 - a. Calla, Square Lay-in
(Model No. 2820: 24"x24"x1" thick) (Model No. 2821: 24"x48"x1" thick.)
(ACT-1 and ACT-2 as noted on finish schedule):
 - 1. Water felted mineral fiber panel.
 - 2. 15/16" square lay-in
 - 3. Surface texture: Smooth
 - 4. Light reflectance = 0.86
 - 5. Flame spread = 25 or less
 - 6. Smoke developed = 50 or less

7. NRC = 0.85
 8. CAC = 35
 9. Class A fire rating
 10. Total recycled content: minimum 50%
 11. Color: White
 2. Acoustical ceiling tile
 - a. Calla, Square Tegular
(Model No. 2824: 24"x24"x 1" thick)
(ACT-3 as noted on finish schedule):
 1. Water felted mineral fiber panel.
 2. 9/16" square tegular
 3. Surface texture: Smooth
 4. Light reflectance = 0.86
 5. Flame spread = 25 or less
 6. Smoke developed = 50 or less
 7. NRC = 0.85
 8. CAC = 35
 9. Class A fire rating
 10. Total recycled content: minimum 50%
 11. Color: White
 3. Type Moisture Resistant Tile
 - a. Georgian – High Washability, Unperforated.
(Model No. 794: 24"x24")
(ACT-4 as noted on finish schedule):
 1. Mineral fiber panel, vinyl latex paint finish and HumiGuard Plus.
 2. Color: White
 3. Square Lay-in, 5/8" thick
 4. BioBlock Plus antimicrobial treatment.
 5. Light reflectance = 0.88
 6. Flame spread = 25 or less per ASTM E84
 7. Smoke developed = 50 or less per ASTM E84
 8. Class A fire rating per ASTM E1264
 9. NRC = N/A
 10. CAC = 33
 11. Total recycled content: minimum 51%
 12. Meets USDA/FSIS guidelines for use in food processing establishments.
- B. Suspension Systems
 1. Standard Exposed Grids
 - a. Prelude XL (Coordinate with ACT-1 and ACT-2 acoustical panels)
 1. Hot dipped galvanized steel with white baked polyester paint finish.
 2. Intermediate duty main runners and cross tees with 15/16" flange face.
 3. Wall angles shall be straight edge and corner caps shall be of same materials and finish.
 4. Suspend with galvanized steel wire.
 5. Total recycled content: minimum 25%

- b. Suprafine XL 9/16" (Coordinate with ACT-3 acoustical panels)
 - 1. Hot dipped galvanized steel with white baked polyester paint finish.
 - 2. Intermediate duty main runners and cross tees with 9/16" flange face.
 - 3. Wall angles shall be straight edge and corner caps shall be of same materials and finish.
 - 4. Suspend with galvanized steel wire.
 - 5. Total recycled content: minimum 25%
- 2. Moisture Resistant Exposed Grid (Coordinate with ACT-4 tile)
 - a. Prelude XL with aluminum cap
 - 1. Hot dipped galvanized steel with white, factory painted aluminum cap.
 - 2. Intermediate duty main runners and cross tees with 15/16" flange face.
 - 3. Wall angles shall be straight edge and corner caps shall be of same materials and finish.
 - 4. Suspend with galvanized steel wire.
 - 5. Total recycled content: minimum 25%
- C. Provide Techzone ceiling system with integrated technical services with ceilings ACT-1, ACT-2 and ACT-3

2.03 **COLORS**

- A. All colors to be selected from manufacturer's standard colors.

2.03 **SIZE**

- A. All ceiling panels shall be 2'x2' or 2'x4' unless otherwise noted.
(See drawings for the size to be used in each area)

PART 3 - EXECUTION

3.01 **EXAMINATION**

- A. Verify that all components in the ceiling plenum are installed. The building shall be in proper condition to receive the acoustical materials and suspension system before any of the material shall be installed. The acoustical material shall be installed under conditions of normal occupancy. All wet work shall be completed, dry, and the building fully enclosed.

3.02 **PROTECTION**

- A. Protect existing elements surrounding the work of this section from damage or disfigurement.

3.03 **INSTALLATION**

- A. Install all acoustical materials and suspension systems in strict accordance with the manufacturer's instructions.
- B. Main runners shall be installed on 24 inch centers and suspended by hanger wire spaced not more than 48 inches on center along the main runners.

- C. Cross tees shall be 24 inches in length and shall be spaced 24 or 48 inches on center along the main runner to form 2'x2' or 2'x4' modules as scheduled on the drawings.
- D. Install wall moldings at intersection of suspended ceiling and all vertical surfaces.
- E. Miter corners where wall moldings intersect or install corner caps.
- F. The acoustical panels shall not be used to support any other materials except fiberglass thermal/sound control insulation installed in the thickness, density and manner specified by the manufacturer.

3.04 ASSOCIATED METAL FRAMING

- A. Provide metal framing as required to support light fixtures, piping, HVAC equipment and ductwork below acoustical ceilings or as required to span across/over/under suspended equipment. Coordinate with the associated MEP contract documents. See Section 05 50 00 - Miscellaneous Metal Work for additional information.

3.05 CLEANING

- A. Clean under provisions of Section 01 70 00.

END OF SECTION

SECTION 09 65 00

RESILIENT FLOORING

PART 1 - GENERAL

1.01 SUMMARY

- A. Related Documents:
The Drawings and general provisions of the Contract, including General and Supplementary General Conditions, and Division 1 Requirements, apply to the work in this Section.

1.02 WORK INCLUDES

- A. Installation of resilient flooring and accessories as indicated.

1.03 RELATED SECTIONS

- A. Section 03 30 00 - Cast in place concrete
- B. Section 04 22 24 – Reinforced Masonry - Interior
- C. Section 09 21 16 - Steel Framed Drywall System
- D. Section 12 32 16 – Plastic Laminate Casework

1.04 REFERENCES

- A. ASTM E84 - Surface Burning Characteristics of Building Materials.
- B. FS L-F-1641 - Floor Covering, Translucent or Transparent Vinyl Surface, with Backing.
- C. FS L-F-475 - Floor Covering, Vinyl Surface (Tile and Roll), with Backing.
- D. FS SS-T-312 - Tile, Floor: Asphalt, Rubber, Vinyl, Vinyl Composition.
- E. FS SS-W-40 - Wall Base: Rubber and Vinyl Plastic.

1.05 SUBMITTALS

- A. Submit shop drawings and product data under provisions of Section 01 33 00.
- B. Provide product data on specified products, describing physical and performance characteristics sizes, patterns and colors available.
- C. Submit samples under provisions of Section 01 33 00.
- D. Submit two samples 3 x 3 inches in size, illustrating the full range color and pattern for each floor material specified.
- E. Submit 6 inch long samples of base material for each color specified.
- F. Submit manufacturer's installation instructions under provisions of Section 01 33 00.

- G. Sustainable Building Material Submittal:
 - 1. Provide documentation indicating percentages of post-consumer and pre-consumer recycled content.
 - 2. Identify each regional material along with the location of its harvest, extraction, or manufacture.

1.06 OPERATION AND MAINTENANCE DATA

- A. Submit cleaning and maintenance data under provisions of Section 01 78 00.
- B. Include maintenance procedures, recommended maintenance materials, and suggested schedule for cleaning, stripping, and re-finishing.

1.07 DELIVERY, STORAGE, AND HANDLING

- A. Deliver, store, protect, and handle work to site under provision of Section 01 60 00.

1.08 ENVIRONMENTAL REQUIREMENTS

- A. Store materials for three days prior to installation in area of installation to achieve temperature stability.
- B. Maintain minimum 70 degrees F air temperature at flooring installation areas for three days prior to, during, and 24 hours after installation of materials.

1.09 EXTRA MATERIALS

- A. Furnish under provisions of Section 01 78 00.
- B. Provide 20 sq. ft. of each color and pattern of floor material and 10 lineal feet of base of each material required for Project, for maintenance use.
- C. Clearly identify each box.

PART 2 - PRODUCTS

2.01 MANUFACTURERS

- A. As noted in the materials noted below.
- B. Substitutions: Under provisions of Section 01 60 00.

2.02 MATERIALS

- A. Linoleum
 - 1. Listed on drawings as LIN1 through LIN4.
 - 2. Manufacturer: Forbo Flooring Systems
 - 3. Style: Marmoleum linoleum sheet resilient floor covering

See the Materials, Color and Finish Schedule on the drawings for specific style and colors used on the project.

4. Material
 - a. Gauge: 1/10 inch
 - b. Backing: Jute
 - c. Width: 79 inches
 - d. Length: 105 feet
 - e. Includes Topshield Pro surface finish.
 - f. Meets all technical requirements per ASTM F2034.
 5. Installation: Install using adhesive as recommended by the flooring manufacturer. Heat weld seams.
 6. Warranty: Limited 30-year warranty.
- B. Rubber floor tiles:
1. Listed on drawings as RUB1 through RUB4.
 2. Manufacturer: Roppe
 3. Style: Renew
See the Materials, Color and Finish Schedule on the drawings for specific style and colors used on the project.
 4. Material
 - a. Thickness: 1/8 inch
 - b. Size: 19-11/16 inches x 19-11/16 inches
 - c. Tile design profile: # 993 Textured Design
 5. Installation: Prepare subfloor in accordance with tile manufacturer's instructions. Install using adhesive as recommended by the flooring manufacturer.
- C. Rubber stair treads with integrated risers:
1. Listed on drawings as RUB5.
 2. Manufacturer: Roppe
 3. Design profile: # 993 Textured Design
 4. 2" height hinged Square Nose, tapering .210" to .113", 20" overall width including 13" tread depth with 7" integrated riser, tread length full width of stair.
 5. Color to be manufacturer's standard marbleized as selected by Architect.
The leading edge of all treads and at the nosing of both main and intermediate landings are all to have a full width, 2" wide co-extruded contrasting solid color insert in standard color as selected by Architect.
 6. Install in accordance with manufacturer's instructions. Install so as tread nosing is scribed to meet riser below to produce a flush face.
- D. Rubber Wall Base:
1. Listed on drawings as B1 and B3.
 2. Manufacturer: Roppe
 3. 4" high x rolled length, 1/8" thick with ribbed back.
 4. See the Materials, Color and Finish Schedule on the drawings for specific style and colors used on the project.
 5. Seams will only be allowed on walls longer than 40'.
- E. Edge guards or Adaptors:
1. Manufacturer: Roppe
 2. Beveled type, matte finish; color as selected by Architect.

3. Provide edge guards at all exposed edges.
4. Provide adaptors at all dissimilar materials (i.e. vinyl tile and carpet).

2.03 COLORS SELECTION

- A. All colors shall be selected by the Architect from the manufacturer's standard color selections.

2.04 ACCESSORIES

- A. Subfloor Filler: White premix latex; mix with water to produce cementitious paste. "Armstrong" S-180 Latex underlayment (or equal).
- B. Primers and Adhesives: Low VOC and waterproof; types recommended by flooring manufacturer for specific materials and as required to maintain product warranty.

PART 3 - EXECUTION

3.01 EXAMINATION

- A. Verify that surfaces are smooth and flat with maximum variation of 1/8 inch in 10 ft., and are ready to receive work.
- B. Documented moisture testing must be conducted on ALL concrete substrates, regardless of the grade level and age using both of the following methods.
 1. Test method ASTM F-1869 result is to be 5.0 lb. MVTR or lower.
 2. Test method ASTM F-2170 result to be less than 75 % RH.
 3. Concrete is to exhibit negative alkalinity, carbonization, or dusting.
- C. Beginning of installation means acceptance of existing substrate and site conditions.

3.02 PREPARATION

- A. Remove sub-floor ridges and bumps. Fill low spots, cracks, joints, holes, and other defects with subfloor filler.
- B. Apply, trowel, and float filler to leave a smooth, flat, hard surface.
- C. Prohibit traffic from area until filler is cured.
- D. Vacuum clean substrate.

3.03 INSTALLATION - TILE MATERIAL

- A. Install in accordance with manufacturers' instructions.
- B. Mix tile from container to ensure shade variations are consistent.
- C. Spread only enough adhesive to permit installation of materials before initial set.
- D. Set flooring in place, press with heavy roller to attain full adhesion.

- E. Install tile with pattern grain alternating with adjacent unit to produce basket weave pattern unless otherwise directed by the Architect. Allow minimum 1/2 full size tile width at room or area perimeter.
- F. Terminate flooring at centerline of door openings where adjacent floor finish is dissimilar.
- G. Install edge guards at unprotected or exposed edges, and where flooring terminates.
- H. Scribe flooring to walls, columns, cabinets, floor outlets, and other appurtenances to produce tight joints.

3.04 INSTALLATION - BASE MATERIAL

- A. Fit joints tight and vertical.
- B. Miter internal corners. At external corners, use premolded units. At exposed ends use premolded units.
- C. Install base on solid backing. Bond tight to wall and floor surfaces.
- D. Scribe and fit to door frames and other interruptions.
- E. Install straight and level to variation of plus or minus 1/8 inch over 10 feet.
- F. Provide coved base at all hard surface flooring and straight base at all carpet.
- G. Provide base at the toekick of all casework.
The color and type shall match adjacent wall base in the room unless selected otherwise by the Architect.

3.05 INSTALLATION - SHEET MATERIAL

- A. Install in accordance with manufacturer's instructions.
- B. Spread only enough adhesive to permit installation of materials before initial set.
- C. Set flooring in place, press with heavy roller to attain full adhesion.
- D. Install sheet flooring parallel to length of room. Provide minimum of 1/3 full roll width. Double cut sheet.
- E. Terminate flooring at centerline of door openings where adjacent floor finish is dissimilar.
- F. Install edge guards at unprotected or exposed edges, and where flooring terminates.
- G. Scribe flooring to walls, columns, cabinets, floor outlets and other appurtenances to produce tight joints.

3.06 PROTECTION

- A. Prohibit traffic on floor finish for 48 hours after installation.

3.07 CLEANING

- A. Remove excess adhesive from floor, base, and wall surfaces without damage.
- B. Clean surfaces in accordance with manufacturer's instructions.

END OF SECTION

SECTION 09 68 14

ENTRANCE CARPET TILE

PART 1 - GENERAL

1.01 SUMMARY

- A. Related Documents:
The Drawings and general provisions of the Contract, including the General Conditions, and Division 1 Requirements, apply to the work in this Section.

1.02 SECTION INCLUDES

- A. Prepare surfaces to receive entrance carpet tiles.
- B. Install entrance carpet tile on surfaces where indicated, complete with required accessories.
- C. Install edge guards where carpeting terminates at other floor finishes.

1.03 RELATED WORK

- A. Section 09 65 00 - Resilient Flooring: Wall base and edge guards.

1.04 DESIGN REQUIREMENTS

- A. Entrance carpet tiles shall be installed in all areas indicated on drawings and finish schedule. All design and color combinations shall be installed as per drawings.

1.05 SUBMITTALS

- A. Submit samples under provisions of Section 01 33 00.
- B. Submit minimum 3"x5" carpet sample of each color of manufacturer's standard colors for architect's selection.
- C. Contractor shall submit larger samples of any standard color if requested by the Architect.
- D. Submit product information indicating conformance with fire code requirements for finishes.

1.06 REGULATORY REQUIREMENTS

- A. Materials must be tested and in compliance with State Code Standards for interior finishes.
- B. Carpet is to meet the following fire code requirements:
 - 1. Flame radiant panel test: Meets NFPA Class 1 when tested under ASTM E-648.
 - 2. Smoke density: NBS smoke chamber NFPA-258 (ASTM E 662) – Less than 450 Flaming Mode

1.07 ENVIRONMENTAL REQUIREMENTS

- A. Maintain room temperature at minimum 60 degrees F for at least 24 hours prior to installation, and relative humidity at approximately that at which the area is to be maintained. The maximum room temperature shall be 90 degrees F. at any time during the installation.
- B. Provide sufficient lighting.

1.08 DELIVERY, STORAGE, AND HANDLING

- A. Deliver, store, and handle products under provisions of Section 01 60 00.

1.09 FIELD MEASUREMENT

- A. Verify all dimensions at site prior to installation.

1.10 SCHEDULING

- A. Do not commence with carpet tile installation until painting and finishing work is complete and ceilings and overhead work, tested, approved, and completed.

1.11 EXTRA MATERIALS

- A. Furnish under provisions of Section 01 78 00.
- B. Provide minimum of 4 carpet tiles of each color and type of tile installed. The additional tiles shall be properly packaged for long term storage.

1.12 WARRANTY

- A. Provide lifetime warranty under provisions of Section 01 78 00.

PART 2 - PRODUCTS

2.01 MANUFACTURERS

- A. Matter Surfaces
- B. Substitutions: Under provisions of Section 01 60 00.

2.02 MATERIALS

- A. Entrance Carpet Tile:
 - 1. Product Data
Listed on drawings as EM1.
Style Name Diagonal Tile
Product type See the Materials, Color and Finish Schedule on the drawings for specific style and colors used on the project.
walk-off tile

- | | |
|--------------------------|---|
| Size | 19-11/16 inch x 19-11/16 inch (50 cm x 50 cm) |
| Dye method | 100% solution dyed |
| Fiber product | UV stabilized polypropylene fibers |
| Primary backing | Bitumen |
| Pile weight | 33.9 ozs/yd ² |
| Pile height | 1/8 inch |
| Total height: | 3/8 inch |
| Recommended installation | quarter-turn |
2. Performance:
 - Flame radiant panel test: Meets NFPA Class 1 when tested under ASTM E-648 glue down.
 - Smoke density: NBS smoke chamber NFPA-258 (ASTM E 662) – Less than 450
 3. Warranty: 3 years
 4. Standard color selection: Minimum of six (6) colors
- B. Adhesive: As recommended by the carpet manufacturer to conform to carpet warranty.
1. VOC Limits: Provide adhesives with VOC content not more than 50 g/L when calculated according to 40 CFR 59, Subpart D (EPA method 24).
- C. Carpet colors selected by architect from manufacturer's Standard colors.

PART 3 - EXECUTION

3.01 EXAMINATION

- A. All floors should be tested for moisture: the presence of moisture will interfere with adhesion.
- B. The floor must be free of all foreign matter; grease, oil, paint, wax, dirt, dust, oil or noncompatible adhesives.
- C. The floor should be sound and level. All holes, compound and any protrusions must be eliminated.

3.02 FLOOR PREPARATION

- A. Concrete (unsealed): Floor must be sealed. Use a compatible non-silicone base sealer or latex primer or latex additives.
- B. Concrete with latex adhesive in good condition: No treatment needed except vacuuming.

3.03 INSTALLATION

- A. Measure the area to find the best starting point that would utilize a maximum size perimeter tile. In some cases, due to doorways or partition, the starting point is not the center of the room.
- B. After selecting the starting point, snap chalk lines that bisect this point at right angles. In order to achieve a perfect right angle, which is critical, form a triangle by measuring 6'x8'x10'.
- C. The chalk lines must be used as a guide for lining up the edges of modules. Using the pyramiding technique, install one quadrant at a time.

- D. The corners of the modules should be flat to assure proper fit. To avoid jamming install modules with slight space about 1/32 or so. We suggest the following spot check: Ten modules, properly spaced, should measure 1/4" to 1/2" over net.
Caution! Do Not Jam Modules.
- E. Use a steel wheel seam roller or similar roller to blend and enhance the seams.
- F. Trimming: The loop pile modules will have some yarn blossoming at the edges, which is inherent to this type of construction. Face yarn may require occasional trimming.

3.04 CLEANING

- A. Clean work under provisions of 01 70 00.

3.05 PROTECTION OF FINISHED WORK

- A. Prohibit traffic on new carpet tile flooring for 24 hours after the completion of installation.

END OF SECTION

SECTION 09 81 16

SOUND ATTENUATION INSULATION

PART 1 - GENERAL

1.01 WORK INCLUDED

- A. Sound attenuation insulation for walls.

1.02 SUBMITTALS

- A. Submit product data and manufacturer's installation instructions under provisions of Section 01 33 00.
- B. Sustainable Building Material Submittal:
 - 1. Provide documentation indicating percentages of post-consumer and pre-consumer recycled content.
 - 2. Identify each regional material along with the location of its harvest, extraction, or manufacture.

1.03 DELIVERY, STORAGE, AND HANDLING

- A. Deliver, store, protect, and handle products under provisions of Section 01 60 00.
- B. Store in a dry, protected area.

PART 2 - PRODUCTS

2.01 ACCEPTABLE MANUFACTURERS

- A. Rockwool AFB evo (Acoustical Fire Batt) by Rockwool.
- B. Other acceptable manufacturers offering equivalent products:
 - 1. Owens Corning Thermafiber SAFB
 - 2. Johns Manville
- C. Substitutions: Under provisions of Section 01 60 00.

2.02 MATERIALS

- A. Sound attention batts: Unfaced mineral wool fiber, non-combustible insulation designed for sound attenuation.
3-1/2" thick in partitions in locations as occurring and noted on drawings
- B. Material Properties
 - 1. Compliance and Performance:
 - ASTM C 665 Mineral-Fiber Blanket Thermal Insulation Type 1, Complies
 - ASTM C 553 Mineral Fiber Blanket Thermal Insulation Complies
 - UL Design Nos U305, U311, U317, U411, U412, U448, U465, V417, V418, V419

2. Fire Performance:
 - ASTM E 136 Behaviour of Materials at 750°C (1382°F) Non-Combustible
 - ASTM E84 (UL 723) Surface Burning Characteristics
 - Flame Spread = 0
 - Smoke Developed = 0
3. Acoustical Performance:
 - ASTM E 90 Airborne Sound Transmission Loss Tested
 - ASTM E 413 Rating Sound Insulation Tested
 - ASTM C 423 Sound Absorption Coefficients Tested
 - ASTM E 1050 Impedance and Absorption of Acoustical Materials Tested
4. Air Erosion:
 - UL 181 Maximum Air Velocity 1000 fpm
5. Corrosive Resistance:
 - ASTM C 665 Corrosiveness to Steel Pass
6. Total recycled content to be 40 %.

C. Acoustical Putty

1. QuietPutty 380 manufactured by Pabco Gypsum or equal.
2. Description: Moldable sheets of fire rated, acoustical putty to be used to seal penetrations in partitions that are constructed with sound attenuation insulation. Use putty to maintain the performance of acoustically rated walls at penetrations.
3. Surface burning requirements: (ASTM E84) Flame Spread 15, Smoke developed: 250, Classification: A.
4. One hour fire-rated to UL 1479
5. Install in accordance with manufacturer's instructions.

PART 3 - EXECUTION

3.01 PREPARATION

- A. Verify adjacent materials are dry and ready to receive installation.
- B. Verify mechanical and electrical services within walls have been installed and tested.

3.02 INSTALLATION

- A. Install batt insulation in accordance with manufacturer's instructions.
- B. Install acoustical insulation of 3 1/2" thickness in walls where indicated on the drawings.
- C. Install batt insulation in spaces without gaps or voids.
- D. Trim insulation neatly to fit spaces. Use batts free of damage.
- E. Fit insulation tight in spaces and tight to exterior side of mechanical and electrical services within the plane of insulation. Leave no gaps or voids.
- F. Install acoustical putty in accordance with manufacturer's instructions in locations as noted below.
 1. Acoustical putty is to be installed at all partitions where sound attenuation insulation is being installed so as to maintain the performance of acoustically rated walls.

2. Install as required to seal around the entire back of all electrical boxes penetrating gypsum board.
3. Install as required to seal all gaps where items penetrate gypsum board, such as HVAC ductwork, piping, conduits, cables, etc.

3.03 CLEANING

- A. Clean under provisions of Section 01 70 00.

END OF SECTION

THIS PAGE INTENTIONALLY LEFT BLANK

SECTION 09 84 15

ACOUSTICAL WALL PANELS

PART 1 – GENERAL

1.1 SUMMARY

- A. This section includes the following:
 - 1. Acoustical Wall Panels
- B. Related Documents:
The Drawings and general provisions of the Contract, including General and Supplementary General Conditions, and Division 1 Requirements, apply to the work in this Section.

1.2 SUBMITTALS

- A. Submit under provisions of Section 01 33 00.
- B. Shop Drawings: Show fabrication and installation details for acoustical wall panels, including plans, elevations, sections, details and attachment to other work.
- C. Submittals: Furnish 4” x 6” sample, color chart showing all manufacture’s full range of colors, texture and patterns available for each type of acoustical product specified.
- D. Product Test Report: From a qualified testing agency indicating wall panels comply with requirements.
- E. Qualification Data: For firms specified in “Quality Assurance” Article to demonstrate their capabilities and experience.

1.3 QUALITY ASSURANCE

- A. Manufacturer Qualification: Manufacture shall have a minimum of 5 years experience in production of specified products and shall furnish supporting documentation showing completed jobs of approximately the same size and scope.
- B. Fire Test Reports: Provide acoustical wall panels with the following surface-burning characteristics as per ASTM E 84.
 - 1. Flame Spread: 25 or less
 - 2. Smoke Developed: 450 or less
- C. Acoustical Test Report: Provide acoustical test report from a qualified testing agency indicating acoustical wall panels NRC per ASTM C-423.

1.4 DELIVERY, STORAGE, AND HANDLING

- A. Deliver, store, protect and handle products to site under provisions of Section 01 60 00.

- B. Protect Acoustical Wall Panels from excessive moisture when shipping, storing, and handling. Deliver in unopened skids and store in a dry place with adequate air circulation. Do not delivery material until all wet-work has been completed.

1.5 WARRANTY

- A. Provide 2 year warranty under provisions of Section 01 78 00.

PART 2 – PRODUCTS

2.1 MANUFACTURER

- A. Manufacturer: MDC Interior Solutions
400 High Grove Blvd. Glendale Heights, IL 60139
Ph. (800) 621-4006
Web: mdcwall.com

- B. Substitutions: Under provisions of Section 01 60 00.

2.2 WALL PANELS, GENERAL

- A. Acoustical Wall Panels shall be as noted below:
(Listed on drawings as AWP1 through AWP5)
 1. Product: Zintra Pattern Acoustic Wall Panels
 2. Pattern: Bhushan
 3. Material: 100% polyester
 4. Panel Thickness: 1/2" thick with backer.
 5. Noise Reduction Coefficient: NRC is between 0.045 and 0.95.
 6. Panel Width: As indicted, 2 or 4 feet wide (See drawings for sizes and quantity)
 7. Panel Length: As indicated, 24", 48" or 108" long. (See drawings for sizes and quantity)
 8. See Materials, Color and Finish Schedule on drawings for colors of panels.

2.3 MOUNTING

- A. Installation shall be direct adhesion to the wall substrate using adhesive recommended by manufacturer.

2.4 FLAMMABILITY RATING

- A. All components shall have a Class A Flammability rating per ASTM E- 84: Surface Burning Characteristics of Building Materials, with a Flame Spread of 25 or less and Smoke Developed of 450 or less

PART 3 – EXECUTION

3.1 INSTALLATION

- A. Install Acoustical Wall panels in locations indicated, top edges level and in alignment with other panels. Comply with manufactures written instructions for installation of panels using the direct adhesion method.

3.2 CLEANING

- A. After completion of installation of panels, remove dust and other foreign material according to manufactures written instructions.
- B. Remove surplus material, rubbish, and debris resulting from panel installation, on completion of the work, and leave areas of installation in a neat and clean condition.

3.3 PROTECTION OF FINISHED WORK

- A. Protect finished product and work under provisions of Section 01 70 00.

END OF SECTION

THIS PAGE INTENTIONALLY LEFT BLANK

SECTION 09 91 00

PAINTING

PART 1 - GENERAL

1.01 SUMMARY

- A. Related Documents:
The Drawings and general provisions of the Contract, including General and Supplementary General Conditions, and Division 1 Requirements, apply to the work in this Section.

1.01 SECTION INCLUDES

- A. Finish painting and priming of all items exposed and identified to receive a finish.

1.02 RELATED SECTIONS

- A. Surfaces scheduled or indicated to be painted.
- B. Touch up of shop coats provided under other sections unless specifically included in that section.
- C. Exposed structural steel.
- D. Finish painting of exposed piping, conduit, exposed raceways, metal hardware, exposed equipment including rooftop equipment supplied under mechanical and electrical trades, when such items have not been factory pre-painted.
- E. Examine the specifications for the various other trades and become thoroughly familiar with all their provisions regarding what they are painting. All exposed-to-view surfaces that are left unfinished by the requirements of other specifications shall be painted or finished as a part of this work.

1.03 REFERENCES

- A. ANSI/ASTM D16 - Definitions of Terms Relating to Paint, Varnish, Lacquer, and Related Products.
- B. ASTM D2016 - Test Method for Moisture Content of Wood.
- C. Federal Specifications

1.04 DEFINITIONS

- A. Conform to ANSI/ASTM D16 for interpretation of terms used in this Section.
- B. The term "paint" as used herein includes enamels, paint, emulsions, varnishes, stains, sealers and other coatings whether used as prime, intermediate or finish coats.

1.05 SUBMITTALS

- A. Submit under provisions of Section 01 33 00.

- B. Submit manufacturer's technical data sheet and Material Safety Data Sheets (MSDS) for each scheduled coating, giving the descriptive data, curing time, mixing, thinning and application instructions. Provide certification that paint was formulated within lead or mercury.
- C. Submit manufacturer's fan deck of color chips for selection of colors by the Architect.
- D. Samples
 - 1. At the request of the Architect, prepare and submit paint samples on the materials he requires for approval.
 - 2. Prepare and submit stained wood samples on the type and quality of wood specified for use on the project as requested by the Architect.
- E. Submit a list of all interior paints and coatings used in the project that are addressed by the Green Seal Standard GS-11 and state the Volatile Organic Compounds (VOC) content for each product.

1.06 QUALIFICATIONS

- A. Product Manufacturer: Company specializing in manufacturing quality paint and finish products with five years experience.
- B. Applicator: Company specializing in commercial painting and finishing with 3 years documented experience.

1.07 REGULATORY REQUIREMENTS

- A. Conform to applicable code for flame/fuel/smoke rating requirements for finishes.

1.08 FIELD SAMPLES

- A. At the request of the Architect, provide field sample panel, one complete surface of each color scheme illustrating special coating, color, texture, finish and workmanship.
- B. Locate where directed by the Architect.
- C. If approved, sample area will serve as a minimum standard for Work throughout the building. Accepted sample may remain as part of the Work.

1.09 DELIVERY, STORAGE, AND HANDLING

- A. Deliver, store, and protect products under provisions of Section 01 60 00.
- B. Deliver all paint materials to the job site ready mixed and in their original containers with all labels intact and legible at time of use.
- C. Store only the approved materials at the job site, and store only in a suitable and designated area restricted to the storage of paint materials and related equipment.
- D. Use all means necessary to insure the safe storage and use of paint materials.

- E. All soiled or used rags, waste and trash must be disposed off site every night and every precaution taken to avoid the danger of fire.
- F. All materials must be stored at above freezing temperature.

1.10 ENVIRONMENTAL REQUIREMENTS

- A. Provide continuous ventilation and heating facilities to maintain surface and ambient temperatures above 45 degrees F for 24 hours before, during, and 48 hours after application of finishes.
- B. Do not apply exterior coatings during rain or snow, or when relative humidity is above 50 percent.
- C. Application Temperature for Paints: 50 degrees F minimum, and 95 degrees F maximum.
- D. Application Temperature for Varnish and Other Natural Finishes: 65 degrees F minimum and 90 degrees F maximum.
- E. Provide lighting level of 80 ft. candles measured mid-height at substrate surface.
- F. Do not apply paint to areas where dust is being generated.

1.11 COORDINATION

- A. Coordinate work under provisions of Section 01 31 00.

1.12 EXTRA MATERIALS

- A. Furnish under provisions of Section 01 78 00 extra paint equaling approximately 10% of each color and gloss used in each coating material used, tightly sealed in clearly labeled containers.
- B. The additional material shall be properly packaged for long term storage and delivered to the Owner.

PART 2 - PRODUCTS

2.01 MANUFACTURER:

- A. Subject to compliance with requirements of this Specification Section, provide products listed herein from one of the following:
 - 1. Paint:
 - a. Sherwin Williams
 - b. Pittsburgh Paint (PPG Industries, Inc)
 - c. Benjamin Moore Paint**
 - 2. Transparent Finishes
 - a. Fine Paints of Europe: Eurolux Waterborne varnishes
 - b. Sutherland Welles Ltd.: Sutherland Wells Low-Toxic wood finishes.
- NOTE: Varnish and stain to have a maximum VOC of 50.
- B. Substitutions: Under provisions of Section 01 60 00.

2.02 COMPATIBILITY:

- A. All paint materials and equipment shall be compatible in use; finish coats shall be compatible with prime coats; prime coats shall be compatible with the surface to be coated; all tools and equipment shall be compatible with the coating to be applied.
- B. Thinners, when used, shall be only those thinners recommended for that purpose by the manufacturer of the material to be thinned.

2.03 MIXING AND TINTING:

- A. Accomplish job mixing and tinting only when acceptable to the Architect. Mix only in mixing pails placed in suitable sized non-ferrous or oxide resistant metal pans.
- B. Tints and all other additives or thinners shall be used only as recommended by the manufacturer of the paint and as approved by the Architect.

PART 3 - EXECUTION

3.01 EXAMINATION

- A. Prior to all work of this Section, carefully inspect the installed work of all other trades and verify that all such work is complete to the point where this installation may properly commence.
- B. In the event of discrepancy, immediately notify the Architect.
- C. Do not proceed with installation in areas of discrepancy until all such discrepancies have been fully resolved.

3.02 PREPARATION:

- A. General
 - 1. Prior to all surface preparation and painting operations, completely mask, remove or otherwise adequately protect all hardware, accessories, machined surfaces, plates, lighting fixtures, and similar items in contact with painted surfaces but not schedule to receive paint.
 - 2. Remove all existing loose, flaking and poor condition paint by scraping and then sanding surface. Sand as required to feather edges of remaining paint.
 - 3. Spot prime all exposed nails and other metals that are to be painted with emulsion paints, using a primer recommended by the manufacturer of the coating system.
 - 4. Surface to be painted shall be thoroughly clean and dry. All concrete and masonry work shall be completely cured.
 - 5. All items concealing surfaces to be painted that are readily detachable shall be removed for the painting of said surface. Reinstall upon completion of space.
 - 6. Surfaces in spaces above suspended ceilings and chases are not required to be painted unless otherwise indicated.
 - 7. Doors shall be removed to paint the bottom edges.
 - 8. Provide minimum of one coat of primer and minimum of two coats of finish paint. The shop priming coat, as occurring, shall substitute for the field applied primer coat.

9. Complete coverage is required. Provide additional coats to areas that do not show complete coverage.
- B. Preparation of wood surfaces:
1. Clean all wood surfaces until they are free from dirt, oil, and all other foreign substance.
 2. Smooth all finished wood surfaces exposed to view, using the proper sandpaper.
 3. Where so required, use varying degrees of coarseness in sandpaper to produce uniformly textured and unmarred wood surfaces.
 4. On small, dry, seasoned knots, thoroughly scrape and clean the surface and apply one coat of good quality knot-sealer before application of the priming coat.
 5. On large, open, unseasoned knots, scrape off all pitch and thoroughly clean the area, followed by an application of one coat of good quality knot-sealer.
 6. Back prime all wood mouldings and trim.
 7. Fill nail holes, cracks, open joints and other defects with oil based putty after priming coat has dried. Color to match finish color.
- C. Preparation of metal surfaces:
1. Galvanized Metal
 - a. Clean all surfaces thoroughly with solvent until they are completely free from dirt, oil and grease.
 - b. Thoroughly treat the cleaned surface with phosphoric acid etch.
 - c. Remove all excess etching solution and allow to dry completely before application of paint.
 - d. Prepare surface in accordance with recommendations of directions of manufacturer of rust-inhibitive primer.
 - e. New galvanized metal is to be allowed to weather 6 months prior to coating. If weathering is not possible, clean with solvents per manufacturer's instructions, and verify test patch adhesion with Architect.
 2. Other Metals
 - a. Thoroughly clean all surfaces until they are completely free from dust, dirt, oil, loose rust and grease.
 - b. All shop-primed surfaces that have been marred or abraded shall be wire-brushed and touched up with the same material as the shop coat prior to painting of surfaces.
- D. Preparation of Concrete and Masonry
1. Concrete and masonry shall be repaired before painting.
 2. Dirt, fungus, grease and oil shall be removed prior to application of paint by washing with a solution composed of from 2 to 8 ounces of tri-sodium phosphate per gallon of hot water and then rinsing thoroughly with fresh water.
 3. Efflorescence shall be removed from concrete and masonry surfaces by scraping, wire brushing and washing with 5 to 10 percent solution of muriatic acid and then washing thoroughly with fresh water.

4. Unless otherwise recommended by the manufacturer of the paint materials as approved, all concrete and masonry surfaces to be painted shall be given a neutralizing treatment consisting of 2 pounds of zinc-sulfate in one gallon of warm water. The neutralizer shall be applied liberally and allowed to dry, following which the surfaces shall be rinsed thoroughly with clean water and allowed to dry for not less than 48 hours before paint is applied.

E. Preparation of Gypsum Wallboard

1. All surfaces must be thoroughly clean and joint treatment dry.
2. Steel corner beads shall be spot primed before water based paint is applied.
3. Do not apply solvent based coatings directly over unpainted wallboard.

3.03 APPLICATION

A. General

1. Apply all paint in accordance with manufacturer's instructions.
2. Do not apply the initial coating until moisture-meter reading of the surface is within limits recommended by the paint materials manufacturer.
3. Allow sufficient drying time between coats in accordance with manufacturer's recommendations.
4. Oil base and Oleo resinous solvent type paints shall be considered dry for recoating when the paint feels firm, does not deform or feel sticky under moderate pressure of the thumb, and the application of another coat of paint does not cause lifting or loss of adhesion of the undercoat.
5. Schedule all cleaning and painting so that dust and other contaminants from the cleaning process will not fall on wet, newly painted surfaces.
6. Sand, dust, and clean between coats to remove all defects visible to the unaided eye from a distance of five feet.
7. Finished surfaces shall be free from runs, drops, ridges, waves, laps, sags and unnecessary brush marks.
8. Slightly vary the color of succeeding coats.
9. Primer and intermediate coats shall be tinted to approximately the tint of finish coats.
10. Damaged painting shall be retouched before applying the succeeding coat.
11. Do not apply additional coats until completed coat has been inspected and approved by the Architect.
12. Only inspected and approved coats of paint will be considered in determining the number of coats applied.
13. Edges of paint abutting other materials or colors shall be clean and sharp with no overlapping.
14. Refinish entire wall where portion of finish has been damaged or is not acceptable.
15. Refinish all woodwork that has been removed and reset.
16. Paint all exposed, plastic drain pipes, electrical conduits, uninsulated metal piping, ceiling & wall access panels, sprinkler piping and ductwork, unless otherwise noted. Verify with Architect prior to painting these items.
17. Colors will be selected by Architect from manufacturer's full color palette.
18. Unlimited number of different colors allowed per project. Multiple colors are allowed per room. Opposite sides of door frames, window frames and doors may be painted different colors at Architect's discretion. Number of colors is to be determined by Architect and

included in a color schedule that will be assembled after submittal of color sample fanex by the General Contractor prior to commencement of work.

19. All steel door frames are to be painted using a brush or roller and back-brushed.
20. Spray painting is not allowed unless all sprayed surfaces are back-brushed using brushes or rollers.

3.04 STAIN & VARNISH PREPARATION AND APPLICATION

- A. Prepare and apply stain and varnish in accordance with manufacturer's instructions.
- B. Do not apply at temperatures lower than 50°F or under high humidity conditions. Surface must be dry, clean and free from grease.
- C. New woodwork: Apply stain and then three coats of varnish. Allow at least a four hour interval for drying between coats. Sand lightly between coats with 220 grit paper or finer and tack dust free. Follow manufacturer's instructions if thinning is required.
- D. Apply varnish with a first quality synthetic brush or lamb's wool applicator
- E. Clean-Up is accomplished using warm water and detergent immediately after use
- F. Drying: Dust free in 45 minutes; recoatable in 4 hours

3.04 CLEANING

- A. Prevent accidental spilling of paint materials and, in event of such spill, immediately remove all spilled material, the waste of equipment used to clean up the spill, and wash the surfaces to their original undamaged condition.
- B. After completion of the painting work, all glass shall be cleaned on both sides by professional window cleaners. The use of acid solution or water containing caustic soaps will not be permitted. The edge of compound shall not be disturbed by scrapers. Upon completion of contract, the glass shall be left whole, free of any defacements or rattle and shall be clean on both sides.
- C. Prior to final inspection visually inspect all surfaces and remove all paint and traces of paint from surfaces not scheduled to be painted.
- D. Paint storage space shall be thoroughly cleaned following the completion of all work.
- E. All waste materials shall be disposed of properly and in accordance with all Federal, State, and Local regulations. Do not dispose of waste materials in the building sanitary waste system.

3.05 WASTE MANAGEMENT

- A. Set aside extra paint for future color matches. All paint unused by the Contractor is to be delivered to the Owner in sealed containers.
- B. Close and tightly seal all partly used paint and finish containers and store in a well-ventilated, safe area at moderate temperature.

- C. Do not dispose of paints or solvents by pouring on ground. Place in designated containers for proper disposal.

3.06 PAINTING SCHEDULE

NOTE: Colors on the Drawing Finish Schedule were selected from Benjamin Moore.

A. Structural Steel

1. After erection of structural steel, but before masonry work is started, all steel to be in contact with earth or in contact with or concealed in masonry shall be given one coat of one of the following asphaltic paints or an approved equal:
Koppers - Bitumastic #50
Tnemec - 46-449 Heavy Duty Black
Devco - Devtar 5A Epoxy highbuild coating

B. Exterior: Based on Sherwin Williams Paints unless noted otherwise.

1. Wood
1st Coat: S-W A-100 Exterior Fast Dry Alkyd Wood Primer
(4 mils wet, 2.2 mils dry)
2nd & 3rd Coats: S-W Resilience Latex Satin K43 Series
(4 mils wet, 1.52 mils dry per coat)
2. Ferrous Metals (doors, frames, steel)
1st Coat: S-W Pro Industrial Pro-Cryl Universal Primer, B66-1300 Series
(5-10 mils wet, 2-4 mils dry)
2nd & 3rd Coats: S-W Pro Industrial DTM Acrylic Semi-Gloss, B66-1150 Series
(6.0 mils wet, 2.5mils dry)
3. Galvanized Metal (designated to be painted)
1st Coat: S-W Pro Industrial Pro-Cryl Universal Primer, B66-1300 Series
(5-10 mils wet, 2-4 mils dry)
2nd & 3rd Coats: S-W Pro Industrial DTM Acrylic Semi-Gloss, B66-1150 Series
(6 mils wet, 2.4 mils dry per coat)
4. Concrete and Masonry Walls
1st Coat: S-W Loxon Block Surfacer
(50 – 100 sq ft/gal)
2nd & 3rd Coats: S-W Resilience Latex Satin K43 Series
(4 mils wet, 1.52 mils dry per coat)
5. PVC, Plastic
1st Coat: 1 coat S-W Adhesion Primer latex, B51W8050
(4 mils wet, 1.7 mils dry)
2nd & 3rd Coats: 2 coats S-W Resilience Exterior Gloss K44
(4 mils wet, 1.6 mils dry per coat)

6. Cementitious Trim
 - 1st Coat: S-W Loxon Exterior Acrylic Masonry Primer, A24W300
(8 mils wet, 3.2 mils dry)
(Delete if factory pre-primed)
 - 2nd & 3rd Coats: S-W Pro Industrial DTM Acrylic Semi-Gloss Coating, B66-Series
(2-4 mils dry per coat)

- C. Interior: Based on Sherwin Williams Paints unless noted otherwise.
 1. Concrete Floor (Epoxy Paint)
Gloss Finish
 - 1st Coat: S-W ArmorSeal Floor-Plex 7100 Primer, B70W410 (243 g/L)
(5 mils wet, 2 mils dry)
 - 2nd & 3rd Coats: S-W ArmorSeal Floor-Plex 7100 Finish, B70-400 Series (258 g/L)
(1.5 - 2 mils dry per coat)Include H&C SharkGrip (or equal) slip resistant additive mixed-in in accordance with manufacturer's instructions in recommended quantities.

 2. CEMENT - (Walls & Ceilings, Poured Concrete, Precast Concrete, Unglazed Brick, Cement Board, Cast-In-Place)
Eg-Shel / Satin Finish
 - 1st Coat: S-W Loxon Block Surfacer
(16 mils wet, 8 mils dry)
 - 2nd & 3rd Coats: S-W ProMar 200 Zero VOC Latex Eg-Shel B20-2600 Series,
(4 mils wet, 1.6 mils dry per coat)

 3. PVC, Plastic
Eg-Shel / Satin Finish
 - 1st Coat: S-W All Surface Enamel Latex Primer, A41W210
(4 mils wet, 1.6 mils dry)
 - 2nd & 3rd Coats: S-W ProMar 200 Zero VOC Latex Eg-Shel B20-2600 Series
(4 mils wet, 1.7 mils dry per coat)

 4. CONCRETE BLOCK
Semi-gloss Finish
 - 1st Coat: S-W Loxon Block Surfacer
(16 mils wet, 8 mils dry)
 - 2nd & 3rd Coats: S-W ProMar 200 Zero VOC Latex Semi-gloss B31-2600 Series
(4 mils wet, 1.7 mils dry per coat)

5. WOOD - (Doors, Trim)
Semi-gloss Finish (Benjamin Moore)
1st Coat: BM Ultra Spec 500 Interior Latex primer (N534)
(4.3 mils wet, 1.4 mils dry).
2nd & 3rd Coats: BM Scuff-X interior semi-gloss finish (487)
(4 - 4.5 mils wet, 1.6 – 1.8 mils dry per coat)

6. DRYWALL - (Walls, Gypsum Board, etc.)
Matte Finish (Benjamin Moore)
1st Coat: BM Ultra Spec 500 Interior Latex primer (N534)
(4.3 mils wet, 1.4 mils dry).
2nd & 3rd Coats: BM Scuff-X interior matte finish (484)
(4 - 4.5 mils wet, 1.6 – 1.8 mils dry per coat)

7. CEILINGS – (Gypsum Board or Plaster)
Flat Finish (Benjamin Moore)
1st Coat: BM Fresh Start High-Hiding All Purpose Primer (046)
(4 mils wet, 1.5 mils dry).
2nd & 3rd Coats: BM Waterborne Ceiling Paint (508)
(3.8 mils wet, 1.4 mils dry per coat).

8. METAL – (Steel pipe railings)
Gloss Finish (Benjamin Moore)
1st Coat: BM Ultra Spec HP Acrylic Metal Primer (HP04)
(1.7 – 2.3 mils dry)
2nd & 3rd Coats: BM Scuff-X interior gloss finish (487)
(4 - 4.5 mils wet, 1.6 – 1.8 mils dry per coat)

9. METAL - (Doors & frames, Structural Steel Columns, Joists, Trusses, Beams,
Miscellaneous & Ornamental Iron, Structural Iron, Ferrous Metal) (exposed,
uninsulated metal piping and ductwork)
Semi-Gloss Finish (Benjamin Moore)
1st Coat: BM Ultra Spec HP Acrylic Metal Primer (HP04)
(1.7 – 2.3 mils dry)
2nd & 3rd Coats: BM Scuff-X interior semi-gloss finish (487)
(4 - 4.5 mils wet, 1.6 – 1.8 mils dry per coat)

10. STAINED WOOD (doors, including jamb edges & trim)

3 Coats of satin varnish, lightly sanded between coats.
a. Stain coat: 1 coat Stain
b. Seal coat: 1 coat Clear Satin Finish
c. First coat: 1 coat Sanding Sealer
d. Finish coat: 1 coat Clear Satin Finish
(Apply in accordance with manufacturer’s instructions)

END OF SECTION

SECTION 10 11 16

MARKERBOARDS

PART 1 - GENERAL

1.01 WORK INCLUDED

- A. Porcelain Enamel Steel Markerboards (Whiteboards)
- B. Trim, marker tray, and accessories.

1.02 RELATED WORK

- A. Section 06 20 10 - Carpentry and Millwork (Wood blocking)

1.03 REFERENCES

- A. American Society for Testing Materials
 - 1. ASTM E84 Standard Test Method for Surface Burning Characteristics for Building Materials
 - 2. ASTM B221 Standard Specification for Aluminum and Aluminum Alloy Extruded Bars, Rods, Wires, Profiles and Tubes
- B. Porcelain Enamel Institute
 - 1. PEI-1002 Manual and Performance Specifications for Porcelain Enamel Writing Surfaces

1.04 SUBMITTALS

- A. Submit shop drawings and product data under provisions of Section 01 33 00.
- B. Indicate on shop drawings, wall elevations, dimensions, joint locations, and special anchor details.
- C. Provide product data on markerboards, trim and accessories.
- D. Submit samples and color charts under provisions of Section 01 33 00.
- E. Submit two samples 3 x 3 inch in size illustrating materials and finish, color, and texture of markerboard.
- F. Submit manufacturer's installation instructions under provisions of Section 01 33 00.

1.05 MAINTENANCE DATA

- A. Submit maintenance data under provisions of Section 01 78 00.
- B. Include maintenance information on regular cleaning, and stain removal.

1.06 DELIVERY, STORAGE, AND HANDLING

- A. Deliver, store, protect and handle products to site under provisions of Section 01 60 00.
- B. Storage shall be in building, closed to the weather with temperatures ranging from 60°F to 85°F at not more than 70% relative humidity.

1.07 WARRANTY

- A. Provide five year warranty under provisions of Section 01 78 00.
- B. Warranty: Include coverage of markerboard surface from discoloration due to cleaning, crazing or cracking, and staining.

PART 2 - PRODUCTS

2.01 MANUFACTURER

- A. Claridge Products and Equipment Company.
- B. Substitutions: Under provisions of Section 01 60 00.

2.02 MATERIALS

- A. Writing Surface Face Sheet – Manufactured in accordance with Porcelain Enamel Institute’s specification.
 - 1. Shall be enameling grade cold rolled steel manufactured from a minimum of 30 percent post-consumer and post-industrial waste.
 - 2. Enameling grade steel shall be coated with LCS³ Porcelain Enamel by Claridge Products and Equipment (or equal)
 - a. 3-Coat process shall include:
 - i. Bottom Ground Coat – 1.5 to 2.2 mils
 - ii. Top Ground Coat – 2.0 to 2.8 mils
 - iii. Top Cover (Color) Coat – 3.0 to 4.0 mils
 - 3. Firing Temperature: Enamel shall be fired at lowest possible temperatures to reduce steel and porcelain stresses and achieve superior enamel and hardness.
 - 4. Color: As selected by architect from manufacturer’s standards.
- B. Writing Surface Core
 - 1. 7/16” Medium Density Fiberboard (MDF).
- C. Writing Surface Backing
 - 1. Aluminum Sheet Back
- D. Factory Framed Markerboards
 - 1. Face Sheet: (Specify LCS³ porcelain enamel steel, magnetic markerboard)
 - 2. Core Material: (Specify 7/16” MDF)
 - 3. Backing: (Aluminum Sheet Back)
 - 4. Series: 4

5. Typical Arrangement: Type CO
6. Color of board: Selected by Architect from manufacturer's standard colors.

2.03 ALUMINUM TRIM

- A. Trim shall be 6063 alloy grade aluminum with T5 tempering in accordance with ASTM B221, and shall have 201-R1 satin anodize finish.
 1. Factory Built Trim
 - a. Series 4
 2. Field-Applied Trim:
 - a. Snap-On, 5/8" face, Aluminum Trim
 - b. No map rail
 - c. Finish: Satin anodized aluminum.
- B. Accessories:
 1. Marker Tray
 - a. Standard continuous, solid, blade-type, flat aluminum tray with ribbed section and injection molded end closures at bottom of each markerboard. Full width of board.

2.04 ACCESSORIES

- A. Provide instructions for board cleaning on metal plate attached to perimeter frame near chalk trough.
- B. Provide two packages LCS Liquid Markers each containing four colors per marker board.
- C. Provide one standard felt eraser per markerboard.

PART 3 - EXECUTION

3.01 INSPECTION

- A. Verify that surfaces and internal wall blocking are ready to receive work, and dimensions are as instructed by the manufacturer.
- B. Beginning of installation means acceptance of substrate construction.
- C. Verify that wall surfaces are true and plumb and are prepared and ready to receive boards.

3.02 INSTALLATION

- A. Deliver factory built units completely assembled and of dimensions shown in details and in accordance with manufacturer's shop drawings as approved by the architect.
- B. Follow manufacturer's instructions for storage and handling of units before installation.
- C. Install markerboards in accordance with manufacturer's instructions with mounting angle clips at top and bottom.
- D. No joints in writing surface shall be permitted in lengths under 16 feet.

- E. Do not install boards on damp walls or in damp and humid weather without heat in the building.
- F. Install level and plumb, keeping perimeter trim straight in accordance with manufacturer's recommendations.

3.03 CLEANING

- A. Clean board surfaces in accordance with manufacturer's instructions.
- B. Cover board surfaces with protective cover, taped to frame for remainder of construction period.
- C. Remove protective cover at Date of Substantial Completion.

3.04 SCHEDULE

- A. See drawings for location, sizes and layout for all markerboards (Whiteboards).

END OF SECTION

SECTION 10 11 23

TACKBOARDS

PART 1 - GENERAL

1.01 WORK INCLUDED

- A. Tackboards
- B. Trim and accessories.

1.02 RELATED WORK

- A. Section 06 20 10 - Carpentry and Millwork (Wood blocking)

1.03 REFERENCES

- A. American Society for Testing Materials
 - 1. ASTM E84 Standard Test Method for Surface Burning Characteristics for Building Materials
 - 2. ASTM B221 Standard Specification for Aluminum and Aluminum Alloy Extruded Bars, Rods, Wires, Profiles and Tubes

1.04 SUBMITTALS

- A. Submit shop drawings and product data under provisions of Section 01 33 00.
- B. Indicate on shop drawings, wall elevations, dimensions, joint locations, and special anchor details.
- C. Provide product data on tackboards, trim and accessories.
- D. Submit samples and color charts under provisions of Section 01 33 00.
- E. Submit two samples 3 x 3 inch in size illustrating materials and finish, color, and texture of tackboard.
- F. Submit manufacturer's installation instructions under provisions of Section 01 33 00.

1.05 MAINTENANCE DATA

- A. Submit maintenance data under provisions of Section 01 78 00.
- B. Include maintenance information on regular cleaning, and stain removal.

1.06 DELIVERY, STORAGE, AND HANDLING

- A. Deliver, store, protect and handle products to site under provisions of Section 01 60 00.

- B. Storage shall be in building, closed to the weather with temperatures ranging from 60°F to 85°F at not more than 70% relative humidity.

1.07 WARRANTY

- A. Provide one year warranty under provisions of Section 01 78 00.

PART 2 - PRODUCTS

2.01 MANUFACTURER

- A. Claridge Products and Equipment Company.
- B. Substitutions: Under provisions of Section 01 60 00.

2.02 MATERIALS

- A. Claridge Cork: Composed of 1/4 inch thick self-healing, burlap backed cork laminated to a 1/4" hardboard backing
- B. Colors: Selected by Architect from manufacturer's standard colors.
- C. Thickness: Total laminated thickness of core and covering is 1/2 inch. All thicknesses are nominal.
- D. Factory Framed Tackboards
 - 1. Tack Surface: Claridge Cork
 - 2. Series: 4
 - 3. Typical Arrangement: Type CO

2.03 ALUMINUM TRIM

- A. Trim shall be 6063 alloy grade aluminum with T5 tempering in accordance with ASTM B221, and shall have 201-R1 satin anodize finish.
 - 1. Factory Built Trim
 - a. Series 4
 - 2. Field-Applied Trim:
 - a. Snap-On, 5/8" face, Aluminum Trim
 - b. No map rail
 - c. Finish: Satin anodized aluminum.

PART 3 - EXECUTION

3.01 INSPECTION

- A. Verify that surfaces and internal wall blocking are ready to receive work, and dimensions are as instructed by the manufacturer.
- B. Beginning of installation means acceptance of substrate construction.
- C. Verify that wall surfaces are true and plumb and are prepared and ready to receive boards.

3.02 INSTALLATION

- A. Deliver factory built units completely assembled and of dimensions shown in details and in accordance with manufacturer's shop drawings as approved by the architect.
- B. Follow manufacturer's instructions for storage and handling of units before installation.
- C. Install tackboards in accordance with manufacturer's instructions with mounting angle clips at top and bottom.
- D. No joints in surface shall be permitted in lengths under 16 feet.
- E. Do not install boards on damp walls or in damp and humid weather without heat in the building.
- F. Install level and plumb, keeping perimeter trim straight in accordance with manufacturer's recommendations.

3.03 CLEANING

- A. Clean board surfaces in accordance with manufacturer's instructions.
- B. Cover board surfaces with protective cover, taped to frame for remainder of construction period.
- C. Remove protective cover at Date of Substantial Completion.

3.04 SCHEDULE

- A. See drawings for location, sizes and layout for all tackboards.

END OF SECTION

THIS PAGE INTENTIONALLY LEFT BLANK

SECTION 10 14 00

SIGNAGE

PART 1 - GENERAL

1.1 SUMMARY

- A. Related Documents: The Drawings and general provisions of the Contract, including General and Supplementary General Conditions, and Division 1 Requirements, apply to the work in this Section.

1.2 SECTION INCLUDES

- A. Miscellaneous interior and exterior building signage.

1.3 RELATED SECTIONS

- A. Section 01 21 00 - Allowances

1.3 SUBMITTALS

- A. Submittal Procedures: Submit product data and samples under provisions of Section 01 33 00.
 - 1. Shop Drawings:
 - a. Indicate sign styles, letter font, terminology, foreground and background colors, locations, and overall dimensions of each sign.
 - b. Setting details for method of installation.
 - 2. Samples: Submit two sample signs illustrating type, style, letter font, and colors specified; method of attachment.
 - 3. Assurance/Control Submittals:
 - a. Certificates: Manufacturer's certificate that products meet or exceed specified requirements.
 - b. Qualification Documentation: Submit documentation of experience indicating compliance with specified qualification requirements.
 - c. Manufacturer's Instructions: Include installation template, attachment devices, and procedures for care of finished surfaces.

1.4 QUALITY ASSURANCE

- A. Qualifications:
 - 1. Manufacturer: Company specializing in manufacturing products specified with minimum 5 years documented experience.
 - 2. Installer: Company specializing in performing the Work of the Section with minimum 5 years documented experience.

1.5 REGULATORY REQUIREMENTS

- A. Conform to all applicable Federal, State and local codes and laws.
- B. All sign design and installation is to meet the requirements of ICC A117.1 and the Rhode Island State Building Code, latest edition.

1.6 DELIVERY, STORAGE, AND HANDLING

- A. Deliver, store and protect products under provisions of Section 01 60 00.
- B. Deliver materials to project site in manufacturer's original unopened protective packaging.
- C. Identify contents, manufacturer, brand name, thermal values, and applicable standards.
- D. Handle as required to prevent damage.

1.7 WARRANTY

- A. Provide manufacturer's standard warranty (minimum of one year) for the specified product under the provisions of Section 01 78 00.

PART 2 - PRODUCTS

2.1 MANUFACTURERS

- A. Subject to compliance with project requirements, manufacturers offering Products which may be incorporated in the Work include the following:
 - 1. ACE Sign Systems
 - 2. ASI Sign Systems
 - 3. Best Sign Systems
 - 4. Approved fabricator.
- B. Substitutions: Under provisions of Section 01 60 00.

2.2 MATERIALS

- A. Interior signage and exterior entrance or directional signage:
 - 1. Solid Polycarbonate Sheet: Thickness to be manufacturer's standard with minimum thickness of 3/16".
 - 2. Impact Resistance: 16 ft-lbf/in. per ASTM D 256, Method A.
 - 3. Tensile Strength: 9000 lbf/sq. in. per ASTM D 638.
 - 4. Flexural Modulus of Elasticity: 340,000 lbf/sq. in. per ASTM D 790.
 - 5. Heat Deflection: 265 deg F_{at} 264 lbf/sq. in. per ASTM D 648.
 - 6. Abrasion Resistance: 1.5 percent maximum haze increase for 100 revolutions of a Taber abramer with a load of 500 g per ASTM D 1044.
- B. Exterior letter signage: Cast aluminum lettering.

2.3 SIGNAGE

- A. Interior Signage:
 - 1. Interior room signs shall have room names and/or numbers composing of minimum one inch high Helvetica Medium (uppercase) lettering that is 1/32 inch raised above their background and is to be duplicated in Braille.
 - 2. Signage design and installation is to meet the requirements of the applicable accessibility code.
 - 3. Size: As shown on drawings and noted in schedule listed herein.
 - 4. Material: Polycarbonate

5. Color: To be selected by Architect from manufacturer's full color range.
6. Install using double stick tape recommended by manufacturer.
7. Pictograms and Symbols of Accessibility:
 - a. Pictograms and Symbols of Accessibility are to meet the requirements of the applicable accessibility code.
 - b. Material: Polycarbonate
 - c. Color: To be selected by Architect from manufacturer full color range.

B. Exterior Entrance or Directional Signage:

1. Exterior signs shall have descriptions composing of minimum one inch high Helvetica Medium (uppercase) lettering that is 1/32 inch raised above their background and is to be duplicated in Braille.
2. Signage design and installation is to meet the requirements of the applicable accessibility code.
3. Size: As shown on drawings and noted in schedule listed herein.
4. Material: Polycarbonate
5. Color: To be selected by Architect from manufacturer's full color range.
6. Install with exposed, stainless steel, theft resistant screw fasteners.

C. Exterior Signage:

1. Provide and install cast aluminum letters in size and font style as selected by the Architect.

2.4 FASTENERS AND OTHER MATERIALS

- A. Provide non-corrosive fasteners, hangers, and mounting devices which are compatible with sign material and finish.

PART 3 - EXECUTION

3.1 EXAMINATION

- A. Verification of existing conditions before starting work.
- B. Verification of Conditions: Verify that field measurements, surfaces, substrates and conditions are as required, and ready to receive work.
1. Examine walls, and other areas scheduled to receive signs for conditions that would affect quality and execution of work.
- C. By beginning work, contractor accepts conditions and assumes responsibility of correcting unsuitable conditions encountered at no additional cost to the client.

3.2 INSTALLATION

- A. Install signage in accordance with manufacturer's published instructions.
- B. Install sign units and components at the locations shown or scheduled, securely mounted to wall. Attach signs to substrates in accordance with the manufacturer's instructions.
- C. Install level, plumb, and at the proper height. Cooperate with other trades for installation of sign units to finish surfaces.

- D. Install room signs on wall on latch side of doors at height required by state and federal accessibility codes.
- E. Where polycarbonate signage is installed on exterior surfaces, exposed, theft resistant, screw fasteners are to be used.
- F. Coordinate and confirm location of all signs with Architect prior to installation.

3.3 CONSTRUCTION

- A. Interface with Other Work:
 - 1. Furnish full-size spacing templates for individually bundled letters and numbers for coordination with work of other trades.

3.4 FIELD QUALITY CONTROL

- A. Inspect signage locations, attachments, and messages to verify installation conforms to drawings.
- B. Verify actual sign locations and terminology with Architect prior to ordering.

3.5 SIGNAGE SCHEDULE

- A. Interior signage: Provide and install signs as noted below.
Coordinate actual pictograms, terminology and locations with Architect.
Content of signs will be similar to room names listed on floor plan drawings.
 - 1. Type "A" signs: 8"h x 8" w with pictographs, lettering and braille.
Quantity: Ten (10)
 - 2. Type "B" signs: 6" h x 6" w with lettering and braille.
Quantity: Seventy five (75)
- B. Exterior signage: Provide and install aluminum letters as shown on drawings A-A2.0 and B-A2.1.
Sizes and fonts are to be selected by the Architect.

END OF SECTION

SECTION 10 14 10

TRAFFIC CONTROL SIGNAGE AND STEEL BOLLARDS

PART 1 - GENERAL

1.1 RELATED DOCUMENTS

- A. Drawings and general provisions of the Contract, including General Conditions and Division 01 – General Requirements, apply to this Section.

1.2 SUMMARY

- A. The work of this Section includes the following:
 - 1. Steel Signage.
 - 2. Concrete-filled Steel Bollards.
- B. Related Sections include the following:
 - 1. Section 31 00 00 - Earthwork.

PART 2 - PRODUCTS

2.1 REFERENCES

- A. D.O.T. Manual - U. S. Department of Transportation Manual on Uniform Traffic Control Devices for Streets and Highways, latest edition.
- B. ASTM - American Society for Testing and Materials.
- C. MUTCD – Manual on Uniform Traffic Control Devices (latest edition)

2.2 ACTION SUBMITTALS

- A. Submit under provisions of Division 01 Section “Submittal Procedures”.
- B. Product Data: Submit manufacturer's product data for the following:
 - 1. Steel Signage.
- C. Shop Drawings: All items listed under paragraph "Work Included" of this Section.

2.3 QUALITY ASSURANCE

- A. Testing Agency Services: Engage an independent laboratory to conduct tests and perform other services as required for quality control during construction.
- B. Source of Materials:
 - 1. Obtain materials of each type from same source for the entire project.
 - 2. Manufacturer shall have minimum 5 years specializing in commercial quality products as specified.
- C. Product Installation: Work shall be carried out by a company with not less than 5 years of successful experience of similar application and installed at least 5 jobs of similar size and complexity.

2.4 PRODUCT DELIVERY, STORAGE, AND HANDLING

- A. Deliver products and materials in original unopened packages, containers, or bundles with manufacturer's label intact and legible.
- B. Remove items delivered in broken, damaged, rusted, or unlabeled condition from project site immediately.
- C. Handle and store so as to avoid damage.

2.5 STEEL SIGNAGE

- A. Sign Material: 18-gauge reflective steel with mounting holes and conforming to the Manual on Uniform Traffic Control Devices and City of Providence Standards.
- B. Sign Graphics: Sign lettering and graphics shall be provided in the sizes, colors, and letter styles as shown on the Drawings.
- C. Sign Manufacturer: Subject to compliance with requirements, provide products by one of the following manufacturers or an approved equal:
 - 1. EMED Co., Inc.
 - 2. Seton Name Plate Company.
- D. Metallic-Coated Steel Sheet: Galvanized-steel sheet or aluminum-zinc alloy-coated steel sheet.
- E. Interior surface of tubes formed from uncoated steel sheet shall be hot-dip zinc coated same as exterior.
 - 1. Posts: Round tubes 2 inches in diameter with 0.108-inch nominal-thickness, metallic-coated steel and hot-dip galvanized after fabrication.
- F. Post Caps: Formed from steel sheet and hot-dip galvanized after forming.
- G. Fasteners: Manufacturer's standard tamperproof, corrosion-resistant, color-coated fasteners matching sign posts with resilient polymer washers.
- H. Galvanizing: For components indicated to be galvanized and for which galvanized coating is not specified in ASTM F 2408, hot-dip galvanize to comply with ASTM A 123/A 123M. For hardware items, hot-dip galvanized to comply with ASTM A 153/A 153M.

2.6 CONCRETE FILLED STEEL BOLLARDS AND HANDICAP BOLLARDS

- A. Steel bollards shall be 6-inch round galvanized steel tube with steel plate welded to steel tube. Size and length as indicated on the Drawings.
 - 1. Concrete: Fill all bollards with concrete in accordance with RIDOT 2022 Standard Specifications for Road and Bridge Construction (including all addenda and revisions), Section 601.

2.7 STEEL AND IRON FINISHES

- A. Galvanizing: Hot-dip galvanize items as indicated to comply with ASTM A 153/A 153M for steel and iron hardware and with ASTM A 123/A 123M for other steel and iron products.

PART 3 - EXECUTION

3.1 STEEL SIGNAGE

- A. Set securely, plumb, and level at locations and elevations indicated on Drawings.
- B. Drill holes in sign post to secure sign panels. Fasten securely with appropriate hardware.
- C. Conform to state and local regulations.

3.2 CONCRETE FILLED STEEL BOLLARDS AND HANDICAP BOLLARDS

- A. Fill bollard with concrete following bollard fabrication and application of shop primed finish. Bollard to be filled prior to installation into concrete foundation.
- B. Set securely, plumb, and level at locations and elevations indicated on Drawings.
- C. Paint with two coats exterior paint, color to be determined by Owner.

END OF SECTION 10 14 10

THIS PAGE INTENTIONALLY LEFT BLANK

SECTION 10 21 13.17

PHENOLIC TOILET PARTITIONS

PART 1 GENERAL

1.1 SUMMARY

- A. Related Documents:
The Drawings and general provisions of the Contract, including General and Supplementary General Conditions, and Division 1 Requirements, apply to the work in this Section.

1.2 SECTION INCLUDES

- A. Phenolic partitions.

1.3 RELATED SECTIONS

- A. Section 05 50 00 - Miscellaneous Metal Work: Concealed steel support members.
- B. Section 06 20 10-Carpentry and Millwork: Concealed wood framing and blocking for compartment support.
- C. Section 10 28 13-Toilet Room Accessories

1.4 REFERENCES

- A. ASTM E 84 - Standard Test Method for Surface Burning Characteristics of Building Materials.

1.5 SUBMITTALS

- A. Submit under provisions of Section 01 30 00.
- B. Product Data : Manufacturer's data sheets on each product to be used, including:
 - 1. Literature indicating typical panel, pilaster, door, hardware and fastening.
 - 2. Preparation instructions and recommendations.
 - 3. Storage and handling requirements and recommendations.
 - 4. Installation methods.
- C. Shop Drawings:
 - 1. Dimensioned plans indicating layout of toilet compartments.
 - 2. Dimensioned elevations indicating heights of doors, pilasters, separation partitions, and other components; indicate locations and sizes of openings in compartment separation partitions for toilet and bath accessories to be installed in partitions; indicate floor and ceiling clearances.
 - 3. Details indicating anchoring components (bolt layouts) and methods for project conditions; indicate components required for installation, but not supplied by toilet compartment manufacturer.

- D. Selection Samples: For each finish product specified, one complete set of color selection guides representing manufacturer's full range of available colors, textures and patterns.
- E. Verification Samples: For each finish product specified, two samples, minimum size 6 inches square, representing actual product, color, texture and pattern.
- F. Manufacturer's Certificates: Certify products meet or exceed specified requirements.

1.6 REGULATORY REQUIREMENTS

- A. Meet all State and Federal Handicap Accessibility and fire codes.

1.7 DELIVERY, STORAGE, AND HANDLING

- A. Deliver, store, protect and handle products to site under provisions of Section 01 60 00.
- B. Store products in manufacturer's unopened packaging until ready for installation.
- C. Lay cartons flat, with adequate support to ensure flatness and to prevent damage to pre-finished surfaces.
- D. Do not store where ambient temperature exceeds 120 degrees F (49 degrees C).

1.8 PROJECT CONDITIONS

- A. Maintain environmental conditions (temperature, humidity, and ventilation) within limits recommended by manufacturer for optimum results. Do not install products under environmental conditions outside manufacturer's absolute limits.
- B. Do not deliver materials or begin installation until building is enclosed, with complete protection from outside weather, and building temperature maintained at a minimum of 60 degrees F.

1.9 COORDINATION

- A. Coordinate Work with placement of support framing and anchors in walls and ceilings.

1.10 WARRANTY

- A. Warranty: Provide warranty for Phenolic Material against delamination, breakage, or corrosion for 25 years, assuming proper maintenance according to manufacturer's recommendations.

PART 2 PRODUCTS

2.1 MANUFACTURERS

- A. Acceptable Manufacturer:
ASI Global Partitions, which is located at: 900 Clary Connector; Eastanollee, GA 30538; Tel: 706-827-2700; Fax: 706-827-2710; Email: request info (sales@asi-globalpartitions.com); Web: www.asi-globalpartitions.com
- B. Requests for substitutions will be considered in accordance with provisions of Section 01 60 00.

2.2 COMPARTMENTS AND SCREENS

- A. Toilet Compartments: Floor anchored/overhead braced.
1. Compartment Depth and Width: As indicated on drawings.
 2. Door Width: As indicated on the Drawings.
 3. Height Above Floor: 12 inches (305 mm).
 4. Door/Panel Height: 58 inches (1473 mm).
 5. Pilaster Height: 82 inches (2083 mm).
- B. Urinal screens are to be attached to the wall with a continuous aluminum bracket and floor to ceiling mounted with a 1-3/4" x 1-3/4" aluminum post. Provide structure above ceiling as required to rigidly brace post. Screen size to be 24" W x 58" H unless noted otherwise on drawings. Height above floor to be 12 inches.

2.3 SOLID PHENOLIC TOILET COMPARTMENTS

- A. Doors, Panels, Screens, and Pilasters: Decorative surface sheet with solid phenolic core of melamine resin impregnated kraft paper fused under high temperature and pressure; edges machine sanded with a 45 degree radius edge. Manufacturer's standard.
1. Doors and Pilasters: 3/4 inch (19 mm) thick.
 2. Panels and Screens: 1/2 inch (13 mm) thick.
 3. Edges: Black core.
 4. Fire Rated Material: Class B.
- B. Finish: Solid phenolic black core, as selected from manufacturer's standard colors.
NOTE: Minimum of 8 colors meeting the above noted rating requirements.
- C. Door Hardware:
1. Hinges:
 - a. Continuous Hinge: Doors shall be hung on a continuous contact piano hinge, made of satin, anodized extruded aluminum and shall weigh not less than 1.5 pounds per foot. Knuckles shall have nylon separators. Pivot pin shall be 1/4" type 304 stainless steel. All fasteners shall be 3/4" tamperproof screws located 8" on-center on door and pilaster. Hinge shall have internal spring which is adjustable to hold door open or closed as required.

2. Brackets: All panel brackets are to be continuous, full height, Satin anodized Type 6463-T5 aluminum, attached with tamperproof screws. Panels and bracket connection shall be through bolted with tamper resistant barrel nuts and shoulder screws.
3. Latches: All slide latches, strikes, door pulls, keepers and coat hook/bumpers are to be manufacturer's standard hardware with a brushed aluminum alloy to resist corrosion and through bolted with tamper resistant barrel nuts and shoulder screws.
Latches for accessible toilet compartments are to meet all state code requirements for accessibility.
All accessible toilet compartments are to have a handle on both sides of door.
4. Fastening Hardware: Manufacturer's standard, Type 304 stainless steel, No. 4 satin finish, with theft-resistant barrel nuts and machine screws.
5. Headrail: Manufacturer's standard anodized aluminum rail with anti-grip profile.
6. Pilaster Anchors, Floor Anchored/Overhead Braced: Easy Stall shoe system. 1/4 inch by 2 inch steel screws attach Easy Stall shoe to floor. Pilaster to be inserted into shoe and secured after height adjusted. Leveling adjustment to be concealed by stainless steel pilaster shoe. Height/leveling adjustment to be made via machine thread bolts inserted into threaded insert in bottom of pilaster. Shoe to be constructed of type 304 stainless steel and to be 3" high.

PART 3 EXECUTION

3.1 EXAMINATION

- A. Do not begin installation until installation conditions and substrates have been properly prepared.
- B. Verify dimensions of areas to receive compartments.
- C. Verify locations of built-in framing, anchorage, bracing, and plumbing fixtures.
- D. Verify substrates have been properly installed.
- E. If installation conditions and substrate preparation is the responsibility of another installer, notify Architect of unsatisfactory preparation before proceeding.

3.2 PREPARATION

- A. Clean surfaces thoroughly prior to installation.

- B. Prepare surfaces using the methods recommended by the manufacturer for achieving the best result for the substrate under the project conditions.

3.3 INSTALLATION

- A. Install in accordance with approved shop drawings and manufacturer's instructions.
- B. Fasten components to adjacent materials and to other components using purpose-designed fastening devices.
- C. Adjust pilaster anchors for substrate variations; conceal anchors with pilaster shoes.
- D. Install door strike keeper on pilasters in alignment with door latch.
- E. Equip each compartment door with one coat hook and bumper.
- F. Installation Tolerances:
 - 1. Maximum variations from plumb or level: 1/8 inch (3 mm).
 - 2. Clearance between wall surface and panels or pilasters: 1-1/2 inch (38 mm) maximum.
- G. Adjust and lubricate hardware for proper operation after installation.
 - 1. Hinges on in-swing doors are factory set to hold doors in the open position when unlatched as shown on drawings.
 - 2. Hinges on out-swing doors are factory set to return to the fully closed position.

3.4 ADJUSTING

- A. Adjust and align hardware to uniform clearance at vertical edge of doors.
- B. Adjust adjacent components for consistency of line or plane.

3.5 PROTECTION

- A. Protect installed products until completion of project.
- B. Touch-up, repair or replace damaged products before Substantial Completion.
- C. Remove factory protective coverings and clean finish surfaces in accordance with manufacturer's instructions before substantial completion.

END OF SECTION

THIS PAGE INTENTIONALLY LEFT BLANK

SECTION 10 22 26

OPERABLE PARTITIONS

PART 1 - GENERAL

1.1 RELATED DOCUMENTS

- A. Drawings and general provisions of the Contract including General and Supplementary Conditions and Division 1 Specification Sections, apply to this Section.

1.2 SUMMARY

- A. This Section includes the following:
 - 1. Electrically operated, continuously hinged partitions.
- B. Related Sections include the following:
 - 1. Division 05 Sections for primary structural support, including pre-punching of support members by structural steel supplier per operable partition supplier's template.
 - 2. Division 06 Sections for wood framing and supports, and all blocking at head and jambs as required.
 - 3. Division 09 Sections for wall and ceiling framing at head and jambs.

1.3 QUALITY ASSURANCE

- A. Installer Qualifications: An experienced installer who is certified in writing by the operable partition manufacturer, as qualified to install the manufacturer's partition systems for work similar in material, design, and extent to that indicated for this Project.
- B. Acoustical Performance: Test operable partitions in an independent acoustical laboratory in accordance with ASTM E90 test procedure and classified in accordance with ASTM E413 to attain no less than the STC rating specified. Provide a complete and unedited written test report by the testing laboratory upon request.
- C. Preparation of the opening shall conform to the criteria set forth per ASTM E557 *Standard Practice for Architectural Application and Installation of Operable Partitions*.
- D. The operable wall must be manufactured by a certified ISO-9001-2015 company or an equivalent quality control system.

1.4 REFERENCE STANDARDS

- A. ASTM International
 - 1. ASTM E557 Standard Practice for Architectural Application and Installation of Operable Partitions.
 - 2. ASTM E90 - Standard Test Method for Laboratory Measurement of Airborne Sound Transmission Loss of Building Partitions and Elements.
 - 3. ASTM E84 - Surface Burning Characteristics of Building Materials.
 - 4. ASTM E413 - Classification for Rating Sound Insulation

- B. International Standards Organization
 - 1. ISO 14021 - Environmental Labels and Declarations - Self-Declared Environmental Claims (Type II Environmental Labeling).
 - 2. ISO 14025:2011-10, Environmental Labels and Declarations - Type III Environmental Declarations - Principles and Procedures.
 - 3. ISO 14040:2009-11, Environmental Management - Life Cycle Assessment - Principles and Framework.
 - 4. ISO 14044:2006-10, Environmental Management - Life Cycle Assessment - Requirements and Guidelines.
 - 5. ISO 21930 – Sustainability in Buildings and Civil Engineering Works — Core Rules for Environmental Product Declarations of Construction Products and Services.
- C. Other Standards
 - 1. ADA – Americans with Disabilities Act
 - 2. UL 508A – Standard for Industrial Control Panels
 - 3. NFPA 70 – National Electrical Code
- D. Conform to all applicable Federal, State and local codes and laws.

1.5 SUBMITTALS

- A. Submit under provisions of Section 01 33 00.
- B. Product Data: Material descriptions, construction details, finishes, installation details, and operating instructions for each type of operable partition, component, and accessory specified.
- C. Shop Drawings: Show location and extent of operable partitions. Include plans, elevations, sections, details, attachments to other construction, and accessories. Indicate dimensions, weights, conditions at openings, and at storage areas, and required installation, storage, and operating clearances. Indicate location and installation requirements for hardware and track, including floor tolerances required and direction of travel. Indicate blocking to be provided by others.
- D. Setting Drawings: Show imbedded items and cutouts required in other work, including support beam punching template.
- E. Samples: Color samples demonstrating full range of finishes available by architect. Verification samples will be available in same thickness and material indicated for the work.
- F. Reports: Provide a complete and unedited written sound test report indicating glass thickness and spacing in test specimen matches product as submitted.
- G. Furnish materials that generate the least amount of pollution.
 - 1. Furnish products and materials that have third party verified environmental product declarations (EPD's). Consider products and materials that have optimized environmental performance (reduced life cycle impacts).

1.6 DELIVERY, STORAGE, AND HANDLING

- A. Deliver, store, protect and handle products to site under provisions of Section 01 60 00.
- B. Clearly mark packages and panels with numbering systems used on Shop Drawings. Do not use permanent markings on panels.
- C. Protect panels during delivery, storage, and handling to comply with manufacturer's direction and as required to prevent damage.

1.7 WARRANTY

- A. Provide written warranty by manufacturer of operable partitions agreeing to repair or replace any components with manufacturing defects.
- B. Warranty period: Three (3) years for the specified product under the provisions of Section 01 78 00.

PART 2 – PRODUCTS

2.1 MANUFACTURERS, PRODUCTS, AND OPERATION

- A. Manufacturers: Subject to compliance with requirements, provide product by the following:
 - 1. Modernfold, Inc.
215 West New Road
Greenfield, IN 46140
Toll Free: 800.869.9685
email: info@modernfold.com
www.modernfold.com

Products: Subject to compliance with the requirements, provide the following product:

- 1. Acousti-Seal Encore™ Automated - #14 Track Systems electrically operated continuously hinged operable partition.
- B. Substitutions: Under provisions of Section 01 60 00.

2.2 OPERATION

- A. Acousti-Seal Encore™ Automated - #14 Track Systems: Series of continuously hinged flat panels, electrically operated, top supported with operable floor seals and automatic top seals.
- B. Final Closure:
 - 1. Electric expanding jamb sealing to panel edge. Manual closures or side seal closures not permitted. Floor track not required or permitted.
- C. Partition shall be operated by:
 - 1. Two push button control stations wired in series and located on opposite sides of the partition. Control stations shall be activated by key switch at stack end of partition.

2. Motor unit shall be reversible, continuous duty, and class A insulated. Motor unit shall have NEMA MG 1 service factor, high starting torque, thermal overload protection, and open/drip proof enclosure. Motor assembly shall have wiring compliant with NFPA 70, 24-volt controls, compliant with UL 508A, and speed of 28 feet/minute. The drive unit motor shall be equipped with outboard limit switches to prevent over-extension. A positive chain drive attached to the lead panel shall pull the partition across the opening. Cable, belt, or other friction type drives will not be accepted.

- D. Electric motor shall be:
 1. 208/230-volt, 1-phase, 1 HP, 7.0 FLA

2.3 PANEL CONSTRUCTION

- A. Nominal 4-1/4-inch thick panels in manufacturer's standard 51-inch widths. All panel horizontal and vertical framing members fabricated from minimum 16-gage formed steel with overlapped and welded corners for rigidity. Top channel is reinforced to support suspension system components. Frame is designed so that full vertical edges of panels are of formed steel and provide concealed protection of the edges of the panel skin.
- B. Panel Skin Options:
 1. Roll-formed steel wrapping around panel edge. Panel skins shall be lock formed and welded directly to the frame for unitized construction. Acoustical ratings of panels with this construction:
 - a. 56 STC - 16-gage steel
- C. Panel Trim: No vertical or horizontal trim required or allowed on edges of panels; minimal groove appearance at panel joints.
- D. Panel Weight:
Steel Skin
 1. 56 STC – 11.9 lbs./square foot

2.4 PANEL FINISHES

- A. Panel face finish shall be:
 1. Full height 1/4-inch (6.35 mm) natural cork tackboard with fabric covering. Fabric selected by Architect from manufacturer's standards.
 2. Provide white marker board on five panels on both sides. 4 foot high by full width of panel with bottom located 42 inches from surface of floor.
- B. Panel trim: No exposed panel trim required or allowed, hardware to be of one consistent color. Color selected by Architect from manufacturer's standard colors.

2.5 SOUND SEALS

- A. Vertical Interlocking Sound Seals between panels: Roll-formed steel astragals, with tongue and groove configuration in each panel edge. Aluminum astragals or rigid plastic astragals are not acceptable.

- B. Horizontal Top Seals shall be Modernfold SureSet™ automatic operable top seals, manually operated operable top seals and/or fixed seals are not required or permitted.
- C. Horizontal Bottom Seals shall be Modernfold SureSet™ bottom seal:
 - 1. SA2E - Automatic bottom seals providing nominal 2-inch (51 mm) operating clearance with an operating range of +1/2-inch (13 mm) to -1-1/2-inch (38 mm) which automatically drop as panels are positioned and final closure made, without the need for tools or cranks.

2.6 SUSPENSION SYSTEM:

- A. #14 Suspension System
 - 1. Suspension Tracks: Minimum 7-gage, 0.18-inch (5 mm) roll-formed steel. Track shall be supported by adjustable steel hanger brackets connected to structural support by pairs of 1/2-inch (13 mm) diameter threaded rods. Brackets must support the load bearing surface of the track.
 - a. Exposed track soffit: Steel, removable for service and maintenance, attached to track bracket without exposed fasteners, and pre-painted off-white.
 - 2. Carriers: All-steel trolleys with steel-tired ball bearing wheels.
 - 3. Warranty period: Ten (10) years.

2.7 OPTIONS

- A. Work Surfaces:
 - 1. Markerboard: White enamel on steel, bonded to the face of the panel with horizontal trim without exposed fasteners. Trim is not acceptable on vertical edges to provide uninterrupted work surface.
See wall elevations on drawings for quantity and location of markerboards on panels.
- B. Accessories:
 - 1. Pocket Doors: Acousti-Seal Pocket Doors by Modernfold, Inc., with same construction, finish, and appearance as the adjacent panels. Equipped with electric interlock system.

PART 3 – EXECUTION

3.1 INSTALLATION

- A. General: Comply with ASTM E557, operable partition manufacturer's written installation instructions, Drawings and approved Shop Drawings.
- B. Install operable partitions and accessories after other finishing operations, including painting have been completed.
- C. Match operable partitions by installing panels from marked packages in numbered sequence indicated on Shop Drawings.
- D. Broken, cracked, chipped, deformed or unmatched panels are not acceptable.

3.2 CLEANING AND PROTECTION

- A. Clean partition surfaces upon completing installation of operable partitions to remove dust, dirt, adhesives, and other foreign materials according to manufacturer's written instructions.
- B. Provide final protection and maintain conditions in a manner acceptable to the manufacturer and Installer that ensure operable partitions are without damage or deterioration at time of Substantial Completion.

3.3 ADJUSTING

- A. Adjust operable partitions to operate smoothly, easily, and quietly, free from binding, warp, excessive deflection, distortion, nonalignment, misplacement, disruption, or malfunction, throughout entire operational range. Lubricate hardware and other moving parts.

3.4 EXAMINATION

- A. Examine flooring, structural support, and opening, with Installer present, for compliance with requirements for installation tolerances and other conditions affecting performance of operable partitions. Proceed with installation only after unsatisfactory conditions have been corrected.

3.5 DEMONSTRATION

- A. Demonstrate proper operation and maintenance procedures to Owner's representative.
- B. Provide Operation and Maintenance Manual to Owner's representative.

END OF SECTION

SECTION 10 26 23.13

IMPACT RESISTANT WALL PROTECTION

PART 1 - GENERAL

1.01 SECTION INCLUDES

- A. This section includes labor, materials and other services necessary to complete impact resistant wall coverings.

NOTE: Listed on drawings as DWP (Durable Wall Paneling).

- B. Conform with requirements of all Sections of Division 1, General Requirements, as it applies to the work of this Section.

1.02 RELATED SECTIONS

- A. Section 04 22 24 - Reinforced Masonry-Interior
- B. Section 09 21 16 - Steel Framed Drywall System
- C. Section 09 28 13 - Cementitious Backer Board

1.03 SYSTEM DESCRIPTION

- A. Performance Requirements: Provide impact resistant wall covering which is to be manufactured and installed to maintain performance criteria stated by manufacturer without defects, damage or failure.

1.04 SUBMITTALS

- A. Submit under provisions of Section 01 33 00.
- B. Product Data: Submit manufacturer's current printed product literature, specifications, and installation instructions.
- C. Shop Drawings: Submit shop drawings to indicate materials, details, and accessories including but limited to the following:
 - 1. Submit a layout diagram indicating the location of each panel and joining method.
- D. Samples: Submit duplicate sample pieces of materials, as well as accessory pieces.
- E. Quality Assurance Submittals: Submit the following:
 - 1. Manufacturer's Instructions: Current published manufacturer's installation and maintenance instructions.
- F. Closeout Submittals: Submit the following:
 - 1. Operation and Maintenance Data: Operation and maintenance data for installed products in accordance with Division 1 Closeout Submittals (Maintenance Data and Operation Data) Section. Include methods for maintaining installed products and precautions against cleaning materials and methods detrimental to finishes and performance.

2. Warranty: Warranty documents specified herein.

1.05 QUALITY ASSURANCE

- A. Installer Qualifications: Installer experienced in performing work of this section who has specialized in installation of work similar to that required for this project with a minimum of 3 years experience.
- B. Mock-ups: Install at project site a job mock-up using acceptable products and manufacturer approved installation methods. Obtain Owner's and Architect's acceptance of finish color, texture and pattern, and workmanship standards.
 1. Mock-Up Size: Coordinate with Architect.
 2. Maintenance: Maintain mock-up during construction for workmanship comparison; remove and legally dispose of mock-up when no longer required.
 3. Incorporation: Mock-up may be incorporated into final construction upon Architect's approval.
- C. Pre-installation Meeting: Conduct pre-installation meeting to verify project requirements, substrate conditions, manufacturer's installation instructions and manufacturer's warranty requirements.

1.06 DELIVERY, STORAGE & HANDLING

- A. Deliver, store, protect and handle products to site under provisions of Section 01 60 00.
- B. Ordering: Comply with manufacturer's ordering instructions and lead time requirements to avoid construction delays.
- C. Deliver materials in manufacturer's original, unopened, undamaged containers with identification labels intact.
- D. Store materials protected from exposure to harmful weather conditions, at temperature and humidity conditions recommended by manufacturer. Panels should be stored flat and be pre-conditioned a minimum of 24 hours in ambient temperatures similar to the prevailing operational conditions.
- E. Store panels in temperature controlled environments. Leave protective film on panel and keep panels stored flat on pallet until ready to use. Storage on uneven surfaces could cause the panels to distort prior to installation.

1.07 WASTE MANAGEMENT AND DISPOSAL

- A. Deposit all packaging materials in appropriate container on site for recycling or reuse.
- B. Avoid using landfill waste disposal procedures when recycling facilities are available.
- C. Keep all discarded packaging away from children.

1.08 PROJECT CONDITIONS

- A. Temperature Requirements: If storage temperature is below 65°F, the wall panel must be moved to a warmer place and allowed to reach this temperature before installation. For further information, refer to current Installation Guide.
- B. Maintain air temperature and structural base temperature at installation area between 65°F and 80°F for 48 hours before, during and 24 hours after installation.

1.09 WARRANTY

- A. Warranty Period shall be for one (1) year commencing on Date of Substantial Completion.

1.10 EXTRA MATERIALS

- A. Provide extra materials of product and adhesives in accordance with Section 01 78 00 - Closeout Submittals.
- B. Provide 40 sq. ft. of extra materials in one piece and from same production run as installed materials.
- C. Clearly identify each wall panel and each container of adhesive.
- D. Deliver to Consultant, upon completion of the work of this section and store where directed.

PART 2 - PRODUCTS

2.01 MANUFACTURERS

- A. Manufacturer: Farmtek
 - 1. 1395 John Fitch Blvd
South Windsor, CT 06074
Phone: 1.800.327.6835
Web Site: www.farmtek.com.
- B. Substitutions: Under provisions of Section 01 60 00.

2.02 HYGIENIC WALL COVERINGS

- A. Poly-Max, 100% high density polyethylene (HDPE) boards
 - 1. Thickness: 1/8 inch
 - 2. Panel Width: 4'-0"
 - 3. Panel Height: Either 8'-0" or 10'-0"
 - 4. Weight 4' x 8' x 1/8" Panel: 18.5 lbs
Weight 4' x 10' x 1/8" Panel: 23.19 lbs
- B. Color is white.

2.03 ACCESSORIES

- A. Adhesive: Use the adhesive recommended by the manufacturer.

2.04 SOURCE QUALITY

- A. Source Quality: Obtain wall products and accessories from a single manufacturer.

PART 3 - EXECUTION

3.01 MANUFACTURER'S INSTRUCTIONS

- A. Compliance: Comply with manufacturer's product data, including product technical bulletins, product catalog, installation instructions and product label instructions for installation.

3.02 EXAMINATION

- A. Site Verification of Conditions: Verify substrate conditions, which have been previously installed under other sections, are acceptable for product installation in accordance with manufacturer's instructions.

3.03 SUBSTRATE PREPARATION

- A. Walls should be smooth and level. High points must be removed and low points filled with filler intended for the substrate and environmental conditions.
- B. Wall panels must be adhered firmly to the wall.
- C. Surfaces must be permanently dry and free from all substances that may contribute to adhesive bond failure.

3.04 PREPARATION

- A. All surfaces must be free from dust and cleaned prior to panel installation. The working environment must also be dust free. Failure to comply with these conditions will reduce the bond strength between the adhesive and substrate, and may cause the panels to debond.
- B. Very absorbent / porous substrates (particularly plaster finishes and unprimed sheetrock) must have a proprietary sealer e.g. PVA primer or similar, applied to the surface a minimum of 12 hours prior to the installation.
- C. All electrical switches, power points etc., should be in a first fix / installation state. All electrical equipment should only be moved or altered by a qualified electrician.
- D. All plumbing should have pipe-work removed to a first fix or installation state and "tails" left protruding from the substrate. The wall panels can then be drilled and slid over the pipe tails. All holes should be drilled 1/8" oversize to allow for expansion, then sealed with Altro Sanitary Sealant. Plumbing should always be done by a qualified plumber.

- E. Hot pipes and steam pipes should be insulated and a 1/8" to 1/4" expansion gap should be created when installing panels around these pipes, then sealed with Sanitary Sealant.
- F. All pipes, fixing bolts, etc. extending through the wall panels should have a minimum 1/8" expansion gap and be sealed using Altro Sanitary Sealant.
- G. If fitting to doorframes, these must be in place prior to installation of the wall panels.
- H. Prior to installation, it is advisable to complete any painting which comes in contact with the wall panels, as sealant used at junctions is non-paintable.
- I. First, check the room using a 6 foot level to ensure all walls are flat, paying particular attention to the corners, window reveals, and door entrances. These need to be inspected to ensure they are free of any debris or irregularities, which could prevent the panels laying flat to the substrate after the adhesive has been applied and the panel installed.

3.05 INSTALLATION

- A. Install the wall panels in accordance with the current manufacturer's Installation Guide.

3.06 CLEANING

- A. The wall panels can be cleaned with a diluted soap/detergent solution.
- B. When cleaning the wall panel surface, we recommend the temperature of water does not exceed 120° F.
- C. Use cleaning materials compliant with USP regulations, including synthetic, non-shedding mops and specified chemical solutions. Manual unidirectional strokes are recommended to avoid spreading contaminants during cleaning process. Sanitized water is also necessary to thoroughly rinse surfaces.
- D. To reduce the buildup of static, cleaning the panels with an anti-static solution is recommended.
- E. Remove construction debris from project site and legally dispose of debris.

3.07 PROTECTION

- A. Do not install near open heat sources (ovens, etc). Stainless steel panels should be used in such areas.

END OF SECTION

THIS PAGE INTENTIONALLY LEFT BLANK

SECTION 10 28 13

TOILET ROOM ACCESSORIES

PART 1 - GENERAL

1.01 SECTION INCLUDES

- A. The furnishing and installation of toilet room accessories as shown on drawings and herein specified.

1.02 RELATED SECTIONS

- A. Section 04 22 24 - Masonry
- B. Section 09 21 16 – Steel Framed Drywall Systems
- C. Section 10 21 13.19 Plastic toilet partitions

1.03 SUBMITTALS

- A. Submit under provisions of Section 01 33 00
- B. Product data: Include manufacturer's illustration of item and installation instructions.
- C. Samples: Provide one sample of item if requested by the Architect. (Sample will be returned)

1.04 QUALITY CONTROL

- A. Work is to be performed in accordance with Section 01 45 00.

1.05 REGULATORY REQUIREMENTS

- A. Conform to all applicable Federal, State and local codes and laws including the state accessibility code for location and height requirements.

1.06 DELIVERY, STORAGE AND HANDLING

- A. Deliver, store, protect, and handle products to site under provisions of Section 01 60 00.

1.07 FIELD MEASUREMENTS

- A. Verify that field measurements are as indicated on drawings. Any inconsistencies or conflicts shall be reported to the Architect prior to installation.

1.08 COORDINATION

- A. Coordinate work under provisions of Section 01 31 00.

- B. Coordinate the work with finish installers, and contractor for all wall openings, blocking, anchors, etc.

1.09 WARRANTY

- A. Provide warranty under provisions of Section 01 78 00.
- B. The bathroom accessories shall be warranted for one year from the date of purchase.

1.10 OPERATION AND MAINTENANCE

- A. All keys, tools and instruction sheets supplied by the manufacturer are to be turned over to the owner.

PART 2 - PRODUCTS

2.01 MANUFACTURER

- A. Bobrick Washroom Equipment, Inc.
- B. Other acceptable manufacturers offering equivalent products.
 - 1. American Specialties, Inc.
 - 2. A&J Washroom Accessories, Inc.

2.02 PRODUCT LIST

- A. Mirror
(T6 as noted on Drawings)
(Bobrick B-2908 or ASI 0600-B) - Stainless steel angle frame with tempered glass mirror. Provide concealed wall hanger with theft resistant locking device.
- B. Grab Bars
(T1, T1a and T1b as noted on Drawings)
 - 1. All grab bars are of 18 gauge, 1-1/2" diameter, satin finish with peened grip, concealed mounting plate and theft resistant screws. (ASI has a snap-on flange cover)
 - a. Straight grab bar (Bobrick B-6806 or ASI 3801)
- C. Grab Bars (for youth)
(T1, T1a and T1b as noted on Drawings)
 - 1. All grab bars are of 18 gauge, all satin finish, concealed mounting plate and 4 set theft resistant screws.
 - a. Straight grab bar 1" diameter (Bobrick B-530 or ASI 3000 Series, Type 01)
- D. Paper towel dispenser (Surface-mounted)
(T5b as noted on Drawings)
(Bobrick B-4262 or ASI Type 20210) - surface mounted with tumbler lock
- E. Paper towel dispenser (recessed)
(T5a as noted on Drawings)
(Bobrick B-359 or ASI Type 0457) recessed

- F. Small Paper towel dispenser
(T5b as noted on Drawings) (see schedule for actual locations)
(Bobrick B-26212 or ASI Type 0215) - surface mounted with tumbler lock
- G. Paper towel dispenser/disposal
(T5 as noted on Drawings)
(Bobrick B3944 or ASI Type 0469) fully recessed 4" deep rough opening, 12 gallon capacity waste container
- H. Paper towel dispenser/disposal (Small)
(T5d as noted on Drawings)
(Bobrick B369 or ASI Type 0462-AD) fully recessed 4" deep rough opening, 2 gallon capacity waste container
- I. Toilet tissue dispenser
(T2 as noted on Drawings)
(Bobrick B-2740 or ASI Type 0264-1A) double roll, heavy duty aluminum, theft resistant spindle.
- J. Feminine napkin disposal
(T3 as noted on Drawings)
(Bobrick B-270 or ASI Type 20852) surface mounted
- K. Soap dispenser
(T4 as noted on Drawings)
(Bobrick B-2012 or ASI Type 0362) surface mounted, automatic liquid dispenser, battery powered
- L. Janitor's shelf and hook strip
(T13 as noted on Drawings)
(Bobrick B-239 or ASI Type 1308-3) 34" long with shelf, 3 rubber mop holders and 4 hooks
- M. Robe hook
(T11 as noted on Drawings)
(Bobrick B-6707 or ASI Type 7340)
- N. Baby Changing Station
(T12 as noted on Drawings)
(American Specialties, Inc. Model 9013-9, horizontal, Type 304 stainless steel – satin finish, surface mounted on the wall with stainless steel collar)
- O. Electric Hand Dryer
(T5c as noted on Drawings)
Xlerator Hand Dryer manufactured by Excel Dryer, Inc. Model XL-SB:

2.03 MATERIALS

- A. Sheet Steel: ASTM A366, cold rolled stretcher leveled; 125 oz/sq. ft. galvanized coating.
- B. Stainless Steel Sheet: ASTM A167, commercial grads, 22 gauge.

- C. Stainless Steel Tubing: ASTM A269, commercial grade, seamless welded.
- D. Adhesive: Epoxy type contact cement.
- E. Fasteners, Screws, and Bolts: Hot dip galvanized. Expansion Shields: Fiber, lead, or rubber as recommended by accessory manufacturer for component and substrate.

2.04 FINISHING

- A. All accessories shall be stainless steel with a satin finish except if specified otherwise in the schedule.

PART 3 - EXECUTION

3.01 PREPARATION

- A. Provide rough-in dimensions and/or templates to site as required.
- B. Verify exact location of accessories with the Architect prior to installation.
- C. Provide all blocking, backup, anchors, mounting kits, etc. as required to install accessories.

3.02 INSTALLATION

- A. Install accessories in accordance with manufacturer's specifications and instructions.
- B. Install accessories plumb, square and level.
- C. Accessories shall be anchored securely.
- D. All items shall be attached with theft resistant fasteners.

3.03 CLEANING

- A. Clean work under provisions of Section 01 70 00.
- B. Protective plastic cover shall remain on accessories until all finishes and tile cleaning is completed.
- C. Upon installation and cleaning by all other trades, the protective covers may be removed and the accessories cleaned as recommended by the manufacturer.
- D. Do not use steel wool or other abrasives on stainless steel.

3.04 ACCESSORY SCHEDULE

Women's Room A115

- 2 mirrors 18"W x 30"H
- 1 42" grab bar
- 1 36" grab bar
- 1 18" grab bar
- 1 paper towel dispenser/disposal
- 1 soap dispenser
- 2 feminine napkin disposals
- 2 toilet tissue dispensers
- 1 Baby Changing Station
- 1 Electric Hand Dryer

Men's Room A114

- 2 mirrors 18"W x 30"H
- 1 42" grab bar
- 1 36" grab bar
- 1 18" grab bar
- 1 paper towel dispenser/disposal
- 1 soap dispenser
- 2 toilet tissue dispensers
- 1 Baby Changing Station
- 1 Electric Hand Dryer

Toilet Rooms A118, A119, A204, C203

Each to have:

- 1 mirror 18"W x 30"H
- 1 42" grab bar
- 1 36" grab bar
- 1 18" grab bar
- 1 paper towel dispenser/disposal (Small)
- 1 soap dispenser
- 1 toilet tissue dispenser
- 1 feminine napkin disposal
- 1 Robe hook on back of door (48 inches above floor)

Toilet Rooms A202

- 1 mirror 18"W x 30"H
- 1 42" grab bar
- 1 36" grab bar
- 1 18" grab bar
- 1 paper towel dispenser/disposal (Small)
- 1 soap dispenser
- 1 toilet tissue dispenser
- 1 feminine napkin disposal
- 1 Baby Changing Station
- 1 Robe hook on back of door (48 inches above floor)

Women's Room B110

- 3 mirrors 18"W x 30"H
- 1 42" grab bar
- 1 36" grab bar
- 1 18" grab bar
- 1 paper towel dispenser/disposal
- 2 soap dispensers
- 4 feminine napkin disposals
- 4 toilet tissue dispensers
- 1 Baby Changing Station
- 1 Electric Hand dryer

Men's Room B109

- 3 mirrors 18"W x 30"H
- 1 42" grab bar
- 1 36" grab bar
- 1 18" grab bar
- 1 paper towel dispenser/disposal
- 2 soap dispensers
- 2 toilet tissue dispensers
- 1 Baby Changing Station
- 1 Electric Hand dryer

Toilet Rooms A104a, A106a

Each to have:

- 1 42" grab bar (Youth)
- 1 36" grab bar (Youth)
- 1 18" grab bar (Youth)
- 1 paper towel dispenser (Recessed) (Located near sinks)
- 2 soap dispensers (Located near sinks)
- 2 toilet tissue dispensers

Janitor rooms A113, B104

Each to have:

- 1 Janitor's shelf and hook strip

Classrooms A104, A106, A107, A108, A109

Break Room A121

Work Room A212

Kitchens B103, C100

Wash Area C108

Event Space B100

Rooms C106, C109, C110

Each to have:

- 1 Small Paper Towel Dispenser
- 1 Soap Dispenser

END OF SECTION

SECTION 10 44 13

FIRE EXTINGUISHERS & CABINETS

PART 1 - GENERAL

- 1.01 SCOPE: Provide and install Fire Extinguisher Cabinets and Fire Extinguishers where indicated on drawings and as herein specified.

PART 2 - PRODUCTS

- 2.01 COMPONENTS: Cabinets (Architectural Series) and Extinguishers shall be as manufactured by Larsen Manufacturing Co., Minneapolis, Minnesota or an approved equal.
- A. Recessed cabinets are to be Model 2409-R2, 24"x9-1/2"x6" inside box dimension recessed with 5/16" flat trim with vertical duo door. (25"x10-1/2"x6-1/4" rough opening)
 - B. Recessed cabinets in fire rated partitions are to be Model FS-2409-R2, 24"x9-1/2"x6" inside box dimension recessed with 5/16" flat trim with vertical duo door. (26-1/8"x11-5/8"x7-1/8" rough opening)
- 2.02 Door and trim are to be one piece construction with 18 gauge steel box, baked on enamel finish to be white. Door to be mounted to frame with continuous piano hinge, rubber roller catch, stainless steel glass clips, laminated safety glass and chrome-plated hardware. Provide a recessed handle.
- 2.03 Fire extinguishers (one per cabinet) shall be multi-purpose dry chemical extinguishers, Model No. MP-5A with UL rating 3A-40 B:C in accordance with Underwriters Standard 299.

PART 3 - EXECUTION

- 3.01 INSTALLATION: Install extinguishers in walls where indicated on contract drawings. Fasten and secure in conformance with the recommendations of the manufacturer. Install cabinets in accordance with state accessibility code. The cabinet handle should be a maximum of 48" above the floor for extinguisher cabinets. The center of the blanket shelf should be a maximum of 48" above the floor for fire blanket / fire extinguisher cabinets. The distance from the floor to the top of the fire extinguisher should be a maximum of 5'-0".

END OF SECTION

THIS PAGE INTENTIONALLY LEFT BLANK

SECTION 11 06 00

MISCELLANEOUS EQUIPMENT AND PRODUCTS

PART 1 - GENERAL

1.01 SECTION INCLUDES

- A. Miscellaneous equipment not requiring a separate specification section.

1.02 SUBMITTALS

- A. Submit under provisions of Section 01 33 00.
- B. Submit shop drawings, product data, and samples as required.

1.03 OPERATION AND MAINTENANCE DATA

- A. Submit under provisions of Section 01 78 00.

1.04 QUALIFICATIONS

- A. The manufacturer and installer's companies must have specialized in the products specified in this section with a minimum of 3 years documented experience.
- B. The installer must be approved by the manufacturer.

1.05 REGULATORY REQUIREMENTS

- A. The product and installation of product shall comply with all Local, State, and Federal codes.

1.06 DELIVERY, STORAGE, AND HANDLING

- A. Deliver, store, protect, and handle products to site under provisions of Section 01 60 00.

1.07 FIELD MEASUREMENTS

- A. Field verify all dimensions prior to fabrication of product.

1.08 COORDINATION

- A. Coordinate work under provisions of Section 01 31 00.
- B. Coordinate installation of product with other trades.

1.09 WARRANTY

- A. Provide warranty under provisions of Section 01 78 00.
- B. Provide standard length manufacturer's warranties with a minimum one year warranty.

PART 2 - PRODUCTS

2.01 MANUFACTURERS

- A. Provide manufacturer and product specified in schedule.
- B. Substitutions: Under provisions of Section 01 60 00.

2.02 FINISHES

- A. Finish shall be as specified in schedule.

PART 3 - EXECUTION

3.01 EXAMINATION

- A. Field verify all dimensions prior to product purchase or fabrication.
- B. Verify and coordinate any possible obstructions. Notify architect of any inconsistencies prior to fabrication.

3.02 PREPARATION

- A. Prepare all surfaces and/openings as required to accept product.

3.03 INSTALLATION

- A. Install product in accordance with manufacturer's specifications and instructions.
- B. Install product plumb, square, and level.

3.04 CLEANING

- A. Clean work under provisions of Section 01 70 00.

3.05 DEMONSTRATION

- A. Provide demonstration under provisions of Section 01 70 00.

3.06 PROTECTION OF FINISHED WORK

- A. Protect finished work under provisions of Section 01 70 00.

3.07 SCHEDULE

A. LAUNDRY WALL SHELF

Basis-of-Design Product: Subject to compliance with requirements, provide the following or equal

1. Manufacturer: Advance Tabco
 - a. Other acceptable manufacturers offering equivalent products.
 1. Global Industrial
 2. Aero Manufacturing
2. Model: AWS-KD-48
 - a. Description: Aluminum, wall-mounted, tab-lock design Knock Down Shelf w/ 1-5/8" bullnose front edge, 1-1/4" upturn edge on sides & rear, all aluminum construction.
 - b. Verify exact location with Architect prior to installation.
3. Quantity: Four (4)
4. Location: Wash Area C108, Temperate C110, Desert C109 and Tropical C106.
5. Size: 48"W x 11-1/8" D

B. ALUMINUM WALL BASE

1. Manufacturer: Diamond Life (or equal)
2. Wall Base molding, satin anodized aluminum, 18 gauge, 6 inches high, no kick.
3. Attachment: construction adhesive of type recommended by manufacturer.
4. Provide pre-formed inside and outside corners
5. See drawings for locations and quantities.

C. BANNER BRACKETS

Basis-of-Design Product: Subject to compliance with requirements, provide the following or equal

1. Available from the Sign Bracket Store
2. Models: 303B-WM-WL-24-KIT (24 inch wide banner bracket)
303B-WM-WL-36-KIT (36 inch wide banner bracket)
3. Quantity: Six (6) 24 inch wide brackets and Six (6) 36 inch wide brackets.
4. Location: Lobby A201
5. Description: Lighted trapeze banner bracket projecting wall mount. Two bullet directional spot lights. Each banner has an upper and lower bracket.

D. STAINLESS STEEL SINK WITH DRAINBOARD

Basis-of-Design Product: Subject to compliance with requirements, provide the following or equal:

1. Manufacturer: Advance Tabco, Spec-Line, 94 Series
2. Model: 94-1-24-36R, size: 58" overall length, drainboard length is 36", bowl size 16" x 20" x 14" deep
 - a. Description: Stainless steel sink with drain board
14 gauge, Type 304 stainless steel, 11" high back splash
1 5/8" O.D. stainless steel tubular legs with adjustable metal feet.
3. Quantity: Three (3)
4. Location: Temperate C110, Desert C109 and Tropical C106.

E. STAINLESS STEEL WORK TABLE

Basis-of-Design Product: Subject to compliance with requirements, provide the following or equal:

1. Manufacturer: Advance Tabco
2. Model: GLG-246, size: 72" x 36" x 35-1/2" high
 - a. Description: Stainless steel commercial work table.
14 gauge, Type 304 stainless steel top with rolled front & rear edges and square sides.
Includes 18 gauge galvanized steel lower shelf.
1 5/8" O.D. galvanized steel tubular legs with adjustable plastic bullet feet.
No backsplash.
3. Quantity: One (1)
4. Location: Desert C106

F. STAINLESS STEEL CABINET

Basis-of-Design Product: Subject to compliance with requirements, provide the following or equal:

1. Manufacturer: Advance Tabco
2. Model: 109HB-SS-305M, size: 60" long x 30" deep x 35-1/2" high
 - a. Description: Stainless steel commercial work table with cabinet below.
14 gauge, Type 304 stainless steel top.
Includes 18 gauge type 430 body with double panel hinged doors and fixed mid-shelf.
Also includes stainless steel tubular legs with adjustable bullet feet.
Has rolled front edge and side & rear square bend edges.
No backsplash.
3. Quantity: On (1)
4. Location: Kitchen C100

G. WASH CENTER

asis-of-Design Product: Subject to compliance with requirements, provide the following or equal:

1. Manufacturer: Geargrid Corporation (or equal)
2. Model: Wash Center
 - a. Description: Durable steel construction with powder coat finish for organizing and storing washing accessories.
 - b. Construction: Heavy-duty tubing and 1/4" wire grid.
3. Quantity: Five (5)
4. Locations: Work Area C111, Wash Area C108,
Temperate C110, Desert C109 and Tropical C106.
5. Size: 25-1/4" H x 60" W.
6. Finish: TGIC powder coat: Color to be selected by Architect from Manufacturer's full range of standard colors.

H. ADJUSTABLE WIRE SHELF UNITS - FREESTANDING

Basis-of-Design Product: following, or equal: Subject to compliance with requirements, provide the following or equal:

1. Manufacturer: Metro
2. Model: Super Erecta Wire Shelving
 - a. Description: Heavy-gauge wire shelving - six shelves per unit.
 - b. Material: Type 304 stainless steel
3. Quantity: Eighteen (18)
4. Location: Storage Rooms A105, A123, C200 and C204
Unit size: 48" wide x 24" deep; Posts: 86-5/8" high

I. CLOTHES WASHER & DRYER (Stacked)

Basis-of-Design Product: Subject to compliance with requirements, provide the following or equal:

1. Manufacturer: Samsung Bespoke
2. Model: Washer: WF53BB8900AT
Dryer: DVE53BB8900T
 - a. Description: 5.3 Cu. Ft. front load washer and 7.6 Cu. Ft. front load dryer, electric
 - b. Color: Silver steel
3. Quantity: One (1) of each
4. Location: Wash Area C108
5. Contractor is required to verify the swing of the doors on the front of the washer & dryer with the Owner. If necessary, the Contractor may have to flip the doors to swing the opposite direction from the swing received from the factory. Coordinate with Owner. Stack one above the other.
6. Overall Size: Washer: 38-3/4" H x 34-1/2" D x 27" W
Dryer: 38-3/4" H x 31-7/16" D x 27" W

J. STAINLESS STEEL WORK TABLE

Basis-of-Design Product: Subject to compliance with requirements, provide the following or equal:

1. Manufacturer: Advance Tabco
2. Model: GLG-247, size: 84" x 24" x 35-1/2" high
 - a. Description: Stainless steel commercial work table.
14 gauge, Type 304 stainless steel top with rolled front & rear edges and square sides.
Includes 18 gauge galvanized steel lower shelf.
1 5/8" O.D. galvanized steel tubular legs with adjustable plastic bullet feet.
No backsplash.
3. Quantity: Two (2)
4. Location: Work Area C111

K. ON- COUNTER REFRIGERATOR

Basis-of-Design Product: Subject to compliance with requirements, provide the following or equal:

1. Manufacturer: Haier
2. Model: HC46SF10SV
 - a. Description: 4.5 Cu. Ft. Compact Refrigerator
 - b. Stainless steel finish door, black body
 - c. Electrical Requirements: 115V, 60 Hz
3. Quantity: One (1)
4. Location: Kitchen C100
5. Overall Size: 32-1/8" H x 22-1/4" D x 20-1/4" W

L. REFRIGERATOR/FREEZER

Basis-of-Design Product: Subject to compliance with requirements, provide the following or equal:

1. Manufacturer: Frigidaire
2. Model: FPHT2097VF
 - a. Description: 20.0 Cu. Ft. Refrigerator/Top Freezer
 - b. Stainless steel finish door, grey body
 - c. Energy Star
3. Quantity: Six (6)
4. Location: Kitchen C100, Work Room A212, Classroom A109, Classroom A104, Classroom A106, Break Room A121
5. Overall Size: 66-3/4" H x 34-3/4" D x 30" W

M. DISHWASHER

1. Manufacturer: Monogram
 - a. Other acceptable manufacturers offering equivalent products.
 1. Miele
 2. Hobart
2. Model: GDT225SSLSS
 - a. Description: 24" Built-in, top control dishwasher, with a capacity of 12 Place Settings.
 - b. Electrical Requirements: 120V, 60 Hz, 15 or 20 amp circuit
 - c. Energy Star, NSF Certified
 - d. Stainless steel finish
3. Quantity: One (1)
4. Location: Break Room A121
5. Size: 23-3/4" W x 32-1/4" H x 23-1/2" D, Weight: 81 lbs.

N. TELEVISION DISPLAY MOUNT

1. Manufacturer: Premier Mounts, www.mounts.com
 - a. Other acceptable manufacturers offering equivalent products.
 1. Peerless
 2. Echogear
2. Model: CTM-MS4 (for 60" diagonal flat screens and larger)
3. Quantity: CTM-MS4: Three (3)
4. Description: 12 degree downward tilt video display mount.
5. Color: Standard Black
6. Installation:
 - a. Provide and install video display mount in accordance with manufacturer's instructions.
 - b. Provide appropriate mounting hardware as required to support the maximum weight of the video display mount assembly in relationship with the wall construction.
 - c. Locations: Classrooms A107, A108 and A109.
 - d. Verify final location and height with Architect prior to installation.

O. VEHICLE GATE

Basis-of-Design Product: Subject to compliance with requirements, provide the following or equal:

1. Manufacturer: Ultra Aluminum (or equal)
2. Description:
 - Single leaf sliding aluminum gate.
 - Frames: Vertical and diagonal 2" square aluminum tubing x 1/8" thickness for superior sag protection.
 - Posts: 4" schedule 40 galvanized x .125 thickness.
 - Gates include a Y-shaped gate receiver for ease of operation.
 - Cantilever Gate frames and tracks are fabricated from Ultrum™ Alloy, a 6005-T5 alloy with a minimum 35,000 psi.
 - Truck assemblies consist of two heavy-duty swivel trucks on four horizontal wheels with factory sealed and lubricated bearings and two high-impact lateral wheels for proper alignment of the truck within the top track.
 - Top tracks conceal truck assemblies for protection against the elements. All truck assemblies are designed to reduce lateral movement. Double track model.

- Powercoat™Finish: When applied, Powercoat™ finish is twice the thickness and hardness of a typical acrylic, baked enamel or “wet paint” finish, making it more durable, fade-resistant and scratch-resistant than other coatings.
 - Colors: Textured Black
 - Cantilever Gates conform to ASTM specification F-1184, and all gate hardware meets or exceeds ASTM specifications F-626 and A-153.
 - Five year limited warranty.
 - OPERATION: Motorized. Provide motor, associated accessories and all electrical as required to connect with Owner installed security system on both the interior and exterior of the wall opening.
 - Provide concrete footings for all posts in depth and size as required by gate manufacturer.
3. Size: 20'-0" wide x 8'-0" high
 4. Quantity: One (1)
 5. Location: Education Center Service Yard at wall.

END OF SECTION

THIS PAGE INTENTIONALLY LEFT BLANK

SECTION 12 24 13

ROLL-UP WINDOW SHADES

PART 1 - GENERAL

1.01 SUMMARY

- A. Section includes: Manually operated, roll-up fabric window shades including mounting and operating hardware.

1.02 SUBMITTALS

- A. Submit under provisions of Section 01 33 00.
 - 1. List of proposed products and product data.
 - 2. Shop drawings showing window openings, dimensions, and attachment method.
 - 3. Samples of fabrics and metal finishes.
 - 4. Window Shade Schedule listing rooms, field verified window dimensions, quantities, type of shade, fabric, and color.
 - 5. Manufacturer's installation and maintenance instructions.

1.03 QUALIFICATIONS

- A. Manufacturer: Company specializing in manufacturing the products specified in this section with minimum of five years documented experience.

1.04 REGULATORY REQUIREMENTS

- A. Conform to all applicable Federal, State and local codes and laws.
- B. Fabric must meet state fire retardant requirements.

1.05 DELIVERY, STORAGE, AND HANDLING

- A. Deliver, store, protect and handle products to site under provisions of Section 01 60 00.
- B. Do not deliver window shades until building is enclosed and construction within spaces where shades will be installed is substantially complete.
- C. Deliver products in manufacturer's original, unopened, undamaged containers with labels intact.
- D. Label containers and shades according to Window Shade Schedule.

1.06 FIELD MEASUREMENTS

- A. Verify that field measurements are as indicated on drawings. Any inconsistencies shall be reported to the architect prior to installation.

1.07 WARRANTY

- A. Provide under provisions of Section 01 78 00: 5 years warranty against defects in materials and workmanship for clutch operating mechanism.

PARTS 2 - PRODUCTS

2.01 ACCEPTABLE MANUFACTURERS

- A. Draper, Inc.
 - 1. Model: Clutch Operated FlexShade
- B. Substitutions: Under provisions of Section 01 60 00.

2.02 MANUALLY OPERATED WINDOW SHADES

- A. Type: Manually operated, vertical roll-up, fabric window shade with bead chain and clutch operating mechanism, mounting brackets, fasteners, and other components necessary for complete installation.
- B. Method of installation: Mounted inside of window opening and extending from head to sill and jamb to jamb.
- C. Operation: Bead chain and clutch operating mechanism allowing shade to stop when chain is released. Designed never to need adjustment or lubrication. Provide preset limit stops to prevent shade from being raised or lowered too far.
 - 1. Clutch mechanism: Fabricated from high carbon steel and molded fiberglass reinforced polyester or injected molded nylon.
 - 2. Control Loop: Stainless steel bead chain hanging at side of window.
NOTE: Provide spring-loaded chain tension device with each loop.
 - 2. Chain location: Right hand side when facing window from interior.
- D. Shade size: As required for size of windows indicated on Drawings. Verify dimensions of windows at site prior to fabrication.
- E. Roller: Fabricated from extruded aluminum, galvanized steel, or enameled steel. Diameter, wall thickness, and material selected by manufacturer to accommodate shade type and size. Provide roller idler assembly of molded nylon and zinc-plated steel pin. Provide sliding pin to allow easy installation and removal of roller.

- F. Brackets: Plated stamped steel suitable for mounting to wall or jamb. Provide size compatible with roller size and with fasteners appropriate for installation conditions. Provide bracket covers. Color selected by Architect.
- G. Provide 3 7/8" fascia with associated endcaps. Color as selected by Architect from manufacturer's standard colors.
- H. Shade slat: Minimum 1/8 by 1 inch aluminum slat encased in heat seamed hem and sealed ends.

2.03 FABRIC

- A. Light Filtering Material:
Draper Phifer Series SheerWeave Fabric SW2400, SW2900 or SW2600 as selected by Architect. Meets NFPA 701 fire rating.
 - 1. PVC coated fiberglass, woven into a full. 35% fiberglass, 65% vinyl on fiberglass. Series models indicate openness 3%, 5% and 10% respectively. Average 11.25 oz./ sq. yd., .017" thick.
- B. Opaque Material:
Draper Opaque SunBloc Series SB9100 (Duopak)
 - 1. Room-darkening fabric constructed of tough, close woven fiberglass coated on both sides with durable, sun-resistant, flexible vinyl. Flame, fade and mildew resistant, washable and tear proof. Opaque 12 oz./ sq. yd. 72" roll width. Fire rating: NFPA-701 1006-Test 1. White on outside, inside color selected by Architect.
- B. Color: As selected by Architect from manufacturer's standard colors.

PART 3 - EXECUTION

3.01 PREPARATION

- A. Field verify window dimensions prior to fabrication.
- B. Coordinate requirements for blocking and structural supports to ensure adequate means for installation of window shades.

3.02 INSTALLATION

- A. Install window shades at locations indicated in window shade schedule and approved shop drawings.
- B. Install in accordance with shade manufacturer's written instructions and approved shop drawings.

3.03 ADJUSTING AND CLEANING

- A. Operate shade through complete cycle of lowering, stopping, and rising to ensure proper operation. Adjust as required for smooth operation.

- B. Clean shade assemblies and protect from damage from construction operations. If damage occurs, remove and replace damaged components or entire unit as required to provide units in their original, undamaged condition.
- C. Clean under provisions of Section 01 70 00.

3.04 PROTECTION OF FINISHED WORK

- A. Protect finished product and work under provisions of Section 01 70 00.

3.05 WINDOW SHADE SCHEDULE

- A. Provide Opaque material shades full height on all exterior windows in the following rooms:
A104, A106, A107, A108, A109
- B. Provide Light Filtering material shades full height on all exterior windows in the following rooms:
A205, A206, A207, A208, A209, A210, A211, A214, A215, A216, A219, C100.

END OF SECTION

SECTION 12 32 16

PLASTIC LAMINATE CASEWORK

PART 1 - GENERAL

1.01 SUMMARY

- A. Related Documents:
The Drawings and general provisions of the Contract, including General and Supplementary General Conditions, and Division 1 Requirements, apply to the work in this Section.

1.02 SECTION INCLUDES

- A. Provide and install all plastic laminate casework, countertops and accessory items as specified herein. Refer to plans for specific details and requirements.

1.03 RELATED SECTIONS

- A. Section 06 20 10 – Carpentry and Millwork
- B. Section 06 61 16 - Solid Surfacing Material
- C. Section 09 65 00 - Resilient Flooring
- D. Section 12 36 45 - Porcelain Slab Countertop
- E. Division 22 - Plumbing

1.04 SUBMITTALS

- A. Submit product data, design data and test reports under provisions of Section 01 33 00.
- B. Submit shop drawings indicating materials, dimensions, cabinet-cut details, and sink locations.
- C. Samples of colors shall be submitted for selection and coordination with other suppliers. Architect may request and retain samples and catalog cuts as required for accessory and special items.
- D. Full-sized sample of base cabinet with door and drawer is to be submitted for review and retained until completion of job for verification and compliance of specifications.
- E. Sustainable Building Material Submittal:
 - 1. Provide documentation indicating percentages of post-consumer and pre-consumer recycled content.
 - 2. Identify each regional material along with the location of its harvest, extraction, or manufacture.

1.05 QUALIFICATIONS

- A. Manufacturer: Company specializing in manufacturing the products specified in this section with minimum five years documented experience.
- B. Installer: Company specializing in performing the work of this section with minimum five years documented experience approved by the manufacturer.

1.06 REGULATORY REQUIREMENTS

- A. Conform to all local, state, and federal codes.
- B. Conform to the State Building Code requirements for accessibility. The following special requirements shall be met, unless noted otherwise on the architectural drawings.
 - 1. Countertop height: With or without cabinet below, not to exceed a height of 34 inches A.F.F., (Above Finished Floor), at a surface depth of 24 inches.
 - 2. Kneespace clearance: Shall be minimum 29 inches A.F.F. at apron, and 30 inches clear span width.
 - 3. 12 inch deep shelving, adjustable or fixed: Not to exceed a range from 9 inches A.F.F. to 48 inches A.F.F.
 - 4. Wardrobe cabinets: Shall be furnished with rod/shelf adjustable to 48 inches A.F.F. at a maximum 21 inch shelf depth.
 - 5. Sink cabinet clearances: In addition to above, upper kneespace frontal depth shall be no less than 8 inches, and lower toe frontal depth shall be no less than 11 inches, at a point 9 inches A.F.F.
 - 6. Provide a removable angled knee panel at all accessible sinks

1.07 PERFORMANCE REQUIREMENTS

- A. The cabinets shall meet certified product test data in accordance with ANSI A161.1-1980, NEMA LD3-2000, and general static load testing performed and certified by an independent testing agency, covering the following areas of product performance, with these minimum results:
 - 1. Base cabinet construction/racking test: 800 lbs.
 - 2. Cabinet front joint loading test: 425 lbs.
 - 3. Wall cabinet static load test: 2,000 lbs.
 - 4. Drawer front joint loading test: 600 lbs.
 - 5. Drawer construction/static load test: 750 lbs.
 - 6. Cabinet adjustable shelf support device/static load test: 300 lbs.
- B. Lamination System: Doors, finished end panels, and other decorative exterior laminate surfaces shall be laminated exterior with .030 inch high-pressure plastic laminate, and interior with .020 inch high-pressure cabinet liner. Lamination with hybrid P.V.A. Type III water resistant adhesive.
- C. Structural Cabinet Body: Cabinet backs shall be minimum 1/2 inch thick, inset from rear of body, and fully bound (dadoed) four sides. Provide 3/4 inch thick stiffeners fastened to back/body as specified herein. Back perimeter shall be toe-nailed with mechanical fasteners for tight interior fitment and direct connection of back panel to body, and sealed with full-perimeter high-strength hot-melt adhesive.
- D. Interior Structure: All cabinets over 36 inches wide shall be furnished with a mechanically fastened, yet removable, vertical divider to reduce horizontal member/shelf deflection. Wall cabinets shall have a clear inside nominal depth of 12 inches unless detailed otherwise.
- E. Shelf Loading: Shelves shall meet the loading/deflection standards of the National Particleboard Association.

- F. Structural Drawer Body: Drawer body shall be doweled with 1/2 inch typical bottom, recessed, fully bound (dadoed) and joint-glued all four sides. Provide under body stiffeners as specified herein.
- G. Structural Cabinet Support: Cabinet sub-base shall be of a separate and continuous ladder-type platform design, leveled and floor mounted prior to cabinet body placement. Material shall be exterior grade plywood. No cabinet sides-to-floor will be allowed.
- H. Quality Standard: Comply with the requirements for modular cabinets in AWI's "Architectural Woodwork Quality Standards."
 - 1. Provide AWI Quality Certification Program labels and certificate indicating that manufactured wood casework complies with requirements.
- I. Formaldehyde binders are not allowed.
- J. All adhesives are to be low VOC.

1.08 DELIVERY, STORAGE HANDLING

- A. Deliver, store, protect and handle products at and to site under provisions of Section 01 60 00.
- B. Casework shall be protected in transit. Store under cover in a ventilated building not exposed to weather or extreme temperature and humidity changes. Do not store or install casework in building until concrete, masonry, and drywall/plaster work is dry.

1.09 FIELD MEASUREMENTS

- A. Verify that field measurements are as indicated on the shop drawings prior to fabrication.

1.10 COORDINATION

- A. Coordinate work of this Section with related work of other Sections as necessary to obtain proper installation of all items under provisions of Section 01 31 00.

1.11 WARRANTY

- A. Provide warranty under provisions of Section 01 78 00.
- B. All materials shall be guaranteed for a period of 5 years from manufacturer's defects and workmanship.

PART 2 - PRODUCTS

2.01 MANUFACTURERS

- A. Subject to compliance with requirements of this Specification Section, provide products listed herein from one of the following:
 - 1. Case Systems
 - 2. Stevens Industries
 - 3. Product custom manufactured to the specifications noted herein.

- B. Basis of Design: Stevens Industries
- C. Substitutions: Under provisions of Section 01 60 00.

2.02 MATERIALS

- A. Laminated Plastics/Finishes:
 - 1. High-pressure plastic laminate, .030 inch in thickness, for exterior surfaces shall meet NEMA LD3-2000 VGL standards including thickness.
 - 2. High-pressure plastic laminate color Selection Available:
 - a. Standard finish from casework manufacturer's standard stock colors. Minimum of 200 selections available.
 - b. Unlimited number of different colors and patterns allowed per project. Number of colors and patterns to be determined by Architect and included in color schedule.
 - 3. Plastic Laminate Balancing Sheet: White high-pressure cabinet-liner, .020 inch in thickness shall meet NEMA LD3-2000 CLS standards. Use for balancing exterior surface laminates.
 - 4. Countertop High-Pressure Plastic Laminate:
 - a. High-pressure plastic laminate, .050 inch thickness Color as selected from manufacturer's stock standard patterns and solid colors.
 - b. Heavy gauge neutral colored backing sheet for balanced construction.
 - 5. Pressure Fused Laminate:
 - a. Melamine resin impregnated, 120 gram PSM minimum, thermofused to core under pressure.
 - b. Shall meet NEMA LD3-2000 VGL standards and NEMA LD3-2000 CLS standards.
 - c. White pressure fused laminate for cabinet interiors behind door and drawers, and underside of wall cabinets.
The interiors of all open cabinets and behind glass doors are to be finished with .030 inch high-pressure plastic laminate. Color selected by Architect from manufacturer's standard colors.
 - d. Shall be balanced at all concealed surfaces with same thermofused melamine. Unsurfaced coreboard or simple backers not allowed.
- B. Core:
 - 1. Particleboard to be of 47 lb. density, and balanced 3-ply construction with moisture content not to exceed 8%. Particle board shall conform to ANSI A208.1-1993, type M-3.
 - 2. Cabinet components shall be of the following minimum core thicknesses:
 - a. 1/2 inch: cabinet backs, drawer body, and drawer bottoms.
 - b. 3/4 inch: door and drawer face, base, wall, and tall cabinet tops and bottoms, cabinet sides, drawer spreaders, cabinet back rear hangstrips, structural dividers, exposed cabinet backs, and shelves in cabinets.
 - c. 1 inch: product-specific work surfaces and library stack shelving unless stack is fitted with vertical divider.

- C. Edging types:
1. FlatEdge PVC. .020 inch. Solid, high-impact, purified, color-thru, acid resistant PVC edging machine-applied with hot melt adhesives, automatically trimmed face, back and corners for uniform appearance. Manufacturer's option of .030 inch high-pressure plastic laminate if PVC match is unavailable.
 2. 3 mm thick PVC. Solid, high-impact, purified, color-thru, acid resistant, pre-lamination primed edging, machine-applied with hot melt adhesives, automatically trimmed, inside/outside length-radiused for uniform appearance, buffed and corner-radiused for consistent design.
- D. Edging Locations. Provide the above specified edging types at the following locations.
1. Door/Drawer-Front edging: 3mm PVC
Color and pattern of PVC is to match the color and pattern of the adjacent plastic laminate casework doors and drawers. Submit sample to be approved by Architect.
 2. Cabinet body edge, including door/drawer front spacer rail: FlatEdge PVC. Color selected from standard colors.
 3. Forward edge of interior body components, interior dividers, shelf, and top edges of drawer body: FlatEdge PVC to match cabinet interior surface color. FlatEdge PVC is to be on all six surfaces of interior adjustable shelving.
- E. Glass: Provide at cabinet doors as shown on drawings
1. 1/4 inch tempered safety glass at all locations.
- F. Hardware
1. Hinges:
 - a. Heavy duty, five knuckle 2 3/4 inch institutional type hinge shall meet ANSI/BHMA A156.9 Grade 1 requirements. Mill ground, hospital tip, Teflon coated tight pin feature with all edges eased. Hinge shall be full wrap around type .095 inch thick steel. Each hinge shall have minimum of 9 screws, #7, 5/8 inch FHMS to assure positive door attachment. 270 degree pivot swing.
 - b. Hinge finish shall be nickel.
 - c. One pair per door to 48 inch height, One and one-half pair over 48 inches in height. Hinge shall accommodate 13/16" thick laminated door and allow 270 degree swing.
 2. Pulls:
 - a. Amerock (or equal), Model: Creased Bow, Part No. BP27016AA, 3-3/4" center-to-center pull, finish is anodized aluminum.
 3. Drawer Slides:
 - a. Provide Knappe & Vogt model 8417 (or equal), full extension, self-closing design with in & out positive stop, ball bearing, epoxy powder coated white finish. Minimum 100 lb dynamic load rating at 50,000 cycles.
 - b. Provide body mounted molded rails for hanging file system for legal or letter size as indicated by manufacturer's model number. Cutting or machining of drawer body/face not allowed.

4. Sliding Doors: Provide doors that slide in top channels with a nylon wheel operating on an inset track. Solid 3/4" doors shall have double channel extrusion tracks both top and bottom.
 5. Catches: Catch shall provide opening resistance in compliance with the Americans with Disabilities Act.
 - a. Provide top-mounted magnetic catch at each base and wall cabinet door.
 - b. Provide two magnetic catches at each tall cabinet door.
 - c. Provide one magnetic catch on both leafs of double door base and wall cabinets.
 - d. Catch housing shall be molded in White.
 6. Adjustable Shelf Supports: Shall be white plastic, twin pin design with anti tip-up shelf restraints for both 3/4 inch and 1 inch shelves. Design shall include keel to retard shelf slide-off, and slot for ability to mechanically attach shelf to clip. Load rating shall be minimum 300 lbs. each support without failure. Cabinet interior sides shall be flush, without shelf system permanent projection.
 7. Label Holders: Provide, on all doors and drawers on the rooms listed below. Holders are steel with anochrome finish to hold a nominal 1 inch x 2 inch card.
 - a. Provide on all doors and drawers in Pre-K Classrooms A124 and A126 only.
 8. Wardrobe Rod: Shall be 1 1/16 inch rod, LH-362, supported by LH-363 flanges.
 9. Coat Hooks:
 - a. Single coat hooks, wall mount - LH-365 Satin Aluminum.
 - b. Double coat hooks, wall mount - LH-366 Satin Aluminum.
- G. Detailed Requirements For Cabinet Construction:
1. Sub-Base:
 - a. Cabinet sub-base shall be separate and continuous (no cabinet body sides-to-floor), water resistant exterior grade plywood with concealed fastening to cabinet bottom. Ladder-type jobsite construction of individual front, back, and intermediates, are to form a secure and level platform to which cabinets attach.
 - b. Sub-base at exposed cabinet end panels shall be recessed 1/4 inch from face of finished end, for flush installation of finished base material by other trades.
 2. Cabinet Top and Bottom:
 - a. Solid sub-top shall be furnished for all base and tall cabinets.
 - b. At cabinets over 36 inches, bottoms and tops shall be mechanically joined by a fixed divider.
 - c. Exterior exposed wall cabinet bottoms shall be Pressure Fused white laminate both sides. Assembly devices shall be concealed on bottom side of wall cabinets.
 3. Cabinet Ends:
 - a. Holes drilled for adjustable shelves 1 1/4 inches on center.
 - b. Exposed exterior cabinet ends shall be laminated with high-pressure plastic laminate, balanced with high-pressure cabinet-liner interior surface.

4. Fixed and Adjustable Shelves:
 - a. Thickness shall be 3/4 inch.
 - b. All shelves are to be full depth of cabinet.

5. Cabinet Backs:
 - a. Cabinet back shall be fully bound (dadoed) into sides, top, and bottom, recessed 7/8 inch from cabinet rear. Rear, unexposed, side of back shall be toe-nailed to cabinet body with mechanical fasteners and solidified with a continuous bead of industrial grade hot melt adhesive.
 - b. Hang rails shall be located at rear of cabinet back and fastened to cabinet sides. Provide minimum of 2 at base, 2 at wall, and 3 at tall cabinets.
 - c. Exposed exterior backs shall be high-pressure plastic laminate balanced with high-pressure cabinet-liner.

6. Door and Drawer Fronts:
 - a. Laminated door and drawer fronts shall be 13/16 inch thick for all hinged and sliding doors. Drawer fronts and hinged doors shall overlay the cabinet body. Maintain a maximum 1/8 inch reveal between pairs of doors, between door and drawer front, or between multiple drawer fronts within the cabinet.
 - b. Stile and Rail doors shall be 13/16 inch thick with full 1/4 inch plate glass. Available hinged or sliding. All exposed lite-opening edges shall be trimmed and glazed with extruded glazing bead.
 - c. Provide a white markerboard finish on sliding, wall cabinet doors above cubbies where noted on the drawings.

7. Drawers:
 - a. Drawer fronts shall be applied to separate drawer body component sub-front.
 - b. Drawer sides shall be doweled and glued to receive front and back, machine squared and held under pressure, to set.
 - c. Drawer bottom shall be fully bound (dadoed) into front, sides, and back. Routing, in drawer body for bottom, shall receive continuous glue. Reinforce drawer bottoms with 1/2 inch x 4 inch front-to-back intermediate underbody stiffeners, mechanically fastened. One at 24 inches, two at 36 inches, and over.

8. Vertical and Horizontal Dividers: One of the following as indicated by cabinet number:
 - a. Natural hardboard 1/4 inch thick, smooth both faces. Secured in cabinet with molded plastic clips.
 - b. Pressure Fused laminate 3/4 inch thickness. Sub-dividers secured in cabinet with molded plastic clips or dowels. Structural dividers in cabinets over 36 inches wide secured in cabinet with mechanical euro fasteners.

9. Door/Drawer Front Rail: Provide minimum 3/4 inch x 6 inch x full width cabinet body rails immediately behind all door/drawer and multiple drawer horizontal joints to maintain exact body dimensions, close off reveal, and be locator for lock strikes.

10. Open wall and base cabinets are to be finished on all interior surfaces, including dividers and shelves, with .030 inch high-pressure laminate, color as selected from casework manufacturer's standards. Pressure Fused Laminate is not acceptable. Shelves are to be finished on all six sides.

- H. Workmanship:
1. All exposed exterior cabinet surfaces shall be .030 inch high-pressure laminate, color as selected from casework manufacturer's standards. Laminate surface/balancing liner to core under controlled conditions by approved and regulated laminating methods to assure a premium lamination. Natural-setting hybrid P.V.A. Type III water resistant adhesives that cure through chemical reaction, containing no health or environmentally hazardous ingredients, are required. Methods requiring heat are not allowed; "contact" methods of laminating are not allowed.
 2. Cabinet parts shall be accurately machined and bored for premium grade quality joinery construction utilizing automatic machinery to insure consistent sizing of modular components. End panels shall be doweled to receive bottom and top.
 3. Back panel shall be fully bound (dadoed) into, and recessed 7/8 inch from the back of cabinet sides, top, and bottom to insure rigidity and a fully closed cabinet. Cabinet back shall be mechanically fastened from rear of body for tight interior fit and sealed with full-perimeter high-strength hot-melt adhesive.
 4. Drawer bottom shall be fully bound (dadoed) and glued into and recessed 1/2 inch up from the bottom of sides, back, and sub-front. Sides of drawer shall be doweled to receive drawer back and sub-front.
 5. 3/4 inch thick hang rails shall be mechanically fastened to end panels of all wall, base, and tall cabinets for extra rigidity and to facilitate installation.
 6. All cases shall be square, plumb, and true.
 7. Provide removable back or knee panels and closure panels for plumbing access at all sink cabinets, and/or where shown on drawings.

PART 3 - EXECUTION

3.01 EXAMINATION

- A. Coordinate work of this Section with related work of other Sections as necessary to obtain proper installation of all items.
- B. Verify site dimensions of cabinet locations in building prior to fabrication.

3.02 INSTALLATION

- A. Install casework in accordance with manufacturer's instructions.
- B. Erect casework straight, level and plumb and securely anchor in place. Scribe and closely fit to adjacent work. Cut and fit work around pipes, ducts, etc.
- C. Install all items complete and adjust all moving parts to operate properly.
- D. Leave surfaces clean and free from defects at time of final acceptance.
- E. Rubber coved base is to be installed at toe space of base cabinets. Color and material is to match base on adjacent walls unless noted otherwise.

3.03 MANUFACTURER'S FIELD SERVICES

- A. Install casework under the supervision of the manufacturer's representative.

3.04 CLEANING

- A. Clean work under provisions of Section 01 70 00.
- B. Remove all cartons, debris, sawdust, scraps, etc. and leave spaces clean and all casework ready for Owner's Use.

3.05 PROTECTION OF FINISHED WORK

- A. Protect finished work under provisions of Section 01 70 00.

END OF SECTION

THIS PAGE INTENTIONALLY LEFT BLANK

SECTION 12 36 45

PORCELAIN SLAB COUNTERTOPS

PART 1 - GENERAL

1.1 SUMMARY

- A. Related Documents:
The Drawings and general provisions of the Contract, including General and Supplementary General Conditions, and Division 1 Requirements, apply to the work in this Section.
- B. Noted as “SS1” on the drawings
- C. Section Includes:
 - 1. Countertops fabricated from porcelain slabs.
 - 2. Backsplashes.
- D. Related Sections:
 - 1. Section 07 92 13: Perimeter sealant joints at walls.
 - 2. Section 12 32 16 - Plastic Laminate Casework

1.2 SUBMITTALS

- A. Submit under provisions of Section 01 33 00.
- B. Product Data:
 - 1. Porcelain slabs.
 - 2. Fabrication and installation adhesives.
- C. Selection Samples: Available standard color patterns.
- D. Verification Samples: Each required color pattern.
 - 1. 8 by 8 inch slabs with exposed edge detail.
- E. Shop Drawings: Each installation.
 - 1. Edge and backsplash profiles.
 - 2. Cutouts for plumbing fixtures.
- F. Sustainable Design Submittals:
 - 1. Product Data: VOC content of adhesives.
 - 2. Laboratory Test Reports: VOC content of adhesives.

1.3 CLOSEOUT SUBMITTALS

- A. Maintenance Data: Cleaning.

- B. Manufacturer warranties transferrable to Owner.

1.4 QUALITY ASSURANCE

- A. Fabricator Qualifications: Shop experienced in fabrication of fabrication of stone, stone agglomerate, and porcelain stoneware panels utilizing water-fed diamond blade cutting and waterjet machining.
- B. Installer Qualifications: Fabricator of products.

1.5 DELIVERY, STORAGE, AND HANDLING

- A. Deliver, store, handle and protect products to site under provisions of Section 01 60 00.
- B. Do not deliver fabrications until building is enclosed and supporting construction is in place.
- C. Store products inside building.
- D. Protect fabrications from abrasion and other damage.
- E. Store slabs vertically on long edges.

1.6 SITE CONDITIONS

- A. Field Measurements: Measure in-place construction as needed for fabrication and execution. No changes to Contract Sum or Contract Time will be allowed for differences between Drawing dimensions and field measurements.
- B. Do not install products until HVAC system is operating at occupancy levels.

1.7 MANUFACTURER WARRANTIES

- A. Provide manufacturer's standard warranty against manufacturing defects under provisions of Section 01 78 00.

PART 2 - PRODUCTS

2.1 MANUFACTURERS

- A. Basis of Design: Crossville, Inc.
- B. Substitutions: Under provisions of Section 01 60 00.

2.2 MATERIALS

- A. Porcelain Slabs: Structurally strengthened with fiberglass mesh bonded to back face.

1. Manufacturer: Crossville, Inc.
2. Product: Crossville Porcelain Countertop®
3. Thickness: 12 mm (0.47 inch).
4. Finish: Unpolished
5. Color Pattern: Standard color pattern selected by Architect.
See the Materials, Color and Finish Schedule on the drawings for specific style and colors used on the project.
6. Physical Characteristics:
 - a. Breaking strength: >4000 N, tested to ISO 10545.4.
 - b. Mohs Scale Hardness: 5 to 7 tested to UNI EN 101.
 - c. MOR: 50 N/sq mm average, tested to ISO 10545-4.
 - d. Resistance to Deep Abrasion: ≤175 mm³, tested to ISO 10545-6.
 - e. Water Absorption: 0.1 percent average, tested to ISO 10545-3.
 - f. Freeze/Thaw Resistance: Classed as Resistant when tested to EN 14614-5.
 - g. Thermal Shock Resistance: Classed as Resistant when tested to ISO 10545-9.
 - h. Resistance to Staining: Passing ASTM C1378 testing.
 - i. Resistance to Chemicals: Passing ASTM C650 testing.

2.3 PERFORMANCE REQUIREMENTS

- A. Materials Transparency – Material Ingredients: Provide copies of all current product disclosures.
 1. Provide at least one of the following:
 - a. Declare Label: Third-party verified.
 - b. Health Product Declaration (HPD): Third-party verified.
- B. Materials Transparency – Environmental Product Declarations: Provide copies of all current product disclosures.
 1. Provide the following:
 - a. Product-specific EPD: Third-party verified, cradle-to-grave scope, current, and specific to the product.
- C. Embodied Carbon:
 1. Product-specific Environmental Product Declaration (EPD) documents Global Warming Potential (GWP) for 1 m² declared unit: 21.0 kg CO₂-eq.
- D. Low-Emitting Materials:
 1. Product is considered an inherently non-emitting source of VOCs resulting from its ceramic composition and lack of integral organic-based coatings.

- E. Chemicals of Concern:
 - 1. Product does not contain any chemical ingredients from the following chemicals of concern lists:
 - a. Living Building Challenge (LBC) Red List.

2.4 INSTALLATION MATERIALS

- A. Fabrication and Installation Adhesives: As recommended by slab manufacturer for Project applications.
 - 1. VOC Content: Maximum 70 g/L.
- B. Fabrication Adhesive: 2-part epoxy or moisture-cured polyurethane adhesive in matching color for mitered edge joints.
- C. Field Assembly Adhesive: Neutral-cure medium modulus silicone sealant or moisture-cured polyurethane adhesive in matching color.
- D. Installation Adhesive: Neutral-cure medium modulus silicone sealant.

2.5 FABRICATION

- A. Cut porcelain countertops accurately to required shapes and dimensions.
- B. Cut holes for sinks, faucets, and any accessories.
- C. Round exposed edges, including cutouts, to 2-3 mm radius and polish to match finish of slab face.
- D. Fabricate inside corners with not less than 5 mm radius and polish to match finish of slab face.
- E. Fabricate back- and end-splashes as separate pieces for field assembly.
- F. Fabricate changes in direction for field assembly butt joints.
- G. Fabricate joints with uniform width.

PART 3 - EXECUTION

3.1 EXAMINATION

- A. Verify that sub tops on supporting casework are level and in plane, with flush joints.
- B. Verify vertical surfaces are plumb and free of irregularities that affect installation.

3.2 PREPARATION

- A. Clean substrates of dirt, dust, and materials that would impair adhesive bond.

3.3 INSTALLATION

- A. Comply with manufacturer's installation instructions.
- B. Set countertops so front edge is parallel to supporting casework.
- C. Secure countertops to sub tops with adhesive spread to uniform thickness.
- D. Secure back- and end-splashes to wall and to countertops with adhesive.
- E. Bond assembly joints with adhesive to provide smooth, hairline appearance. Mask surfaces adjacent to joints to protect exposed surfaces from adhesive smears.
- F. Tolerances:
 - 1. Level, Plane: 1/8 inch maximum deviation in 12 feet.
 - 2. Field Joints: Flush, no lippage.

3.4 PROTECTING AND CLEANING

- A. Remove adhesive misapplications from exposed surfaces immediately.
- B. Clean exposed surfaces after installation and provide temporary covering to protect against abrasion, staining, and other damage. Use non-abrasive cleaning agents.
- C. Provide new replacements for components that are damaged or have soiling or staining that cannot be satisfactorily cleaned.

END OF SECTION

THIS PAGE INTENTIONALLY LEFT BLANK

SECTION 13 34 18

PRE-ENGINEERED TIMBER COLUMN STRUCTURE

PART 1 - GENERAL

1.01 SECTION INCLUDES

- A. Pre-Engineered factory and field fabricated Timber Column Structure
- B. Prefinished metal roofing and siding panels
- C. Prefinished metal trim items
- D. Prefinished soffits
- E. Pre finished gutters and downspouts
- F. Insulation, interior framing and liner package
- G. Personnel doors and windows.

1.02 PRODUCTS FURNISHED BUT NOT INSTALLED UNDER THIS SECTION

- A. None

1.03 RELATED SECTIONS

- A. Section 03 30 00 – Cast-in-place Concrete

1.04 REFERENCE STANDARDS

- A. Preservative Treated Lumber
 - 1. American Wood Protection Association (AWPA)
 - a. Commodity Specification C2 (2001), Preservative Treatment By Pressure Processes
 - b. Use Category System U1, User Specification for Treated Wood
 - c. UC4A (Important Structural – Ground Contact)
 - d. UC4B (Structural Support – Ground Contact)
 - e. Items treated under AWPA standards shall bear the quality mark of an independent testing agency or service
 - 2. International Code Council Evaluation Service (ICC-ES)
 - a. Items treated under ICC-ES reports shall meet or exceed the applicable standard and shall bear the quality mark of an independent testing agency or service
 - 3. Federal Specification TT-W-571-J.
- B. Framing Lumber
 - 1. Lumber Grading Rules and Wood Species
 - a. National Design Specification for Wood Construction, current edition
 - b. Northeastern Lumber Manufacturer's Association, Inc. (NELMA)
 - c. Southern Pine Inspection Bureau (SPIB)
 - d. West Coast Lumber Inspection Bureau (WCLIB)
 - e. Western Wood Products Association (WWPA)

- C. Wood Trusses
1. All lumber used in the design of wood trusses shall be kiln dried to maximum 19% moisture content and graded in accordance with the current grading rules. Design stresses allowed are those listed in the current editions of the respective Lumber Association's grading rules.
 2. The design of wood members shall be in accordance with the formulas published in the 2001 edition of the National Design Specification for Wood Construction.
 3. Light metal toothed connector plates and joint design shall conform to specifications as set forth in the 2002 edition of Truss Plate Institute's Design Specification for Metal Plate Connected Wood Trusses (TPI-2002).
 - a. Connector plates shall be fabricated in accordance with applicable ICC-ES standards.
 4. Truss members and joints shall be designed in accordance with TPI-2002. All truss designs shall be accompanied by complete and accurate shop drawings and contain the following information:
 - a. Slope or depth, span and spacing of the truss
 - b. Heel bearing height
 - c. Design loading to include:
 1. Top chord live load
 2. Top chord dead load
 3. Bottom chord dead load
 4. Concentrated loads and their points
 - d. Adjustments to lumber and plate design values for conditions of use
 - e. Plate type, thickness of gauge and size
 - f. Lumber size, species and grade for each member

1.05 SYSTEM DESCRIPTION

- A. Clear span
- B. Bay spacing
- C. Primary framing
1. Columns
 2. Truss
 3. Wind bracing
- D. Secondary framing
1. Perimeter baseboards and preservative treatment
 2. Wall girts
 3. Purlin
 4. Overhang rafters and fascia
 5. Ancillary blocking or furring as required
- E. Roof Covering
1. Prefinished ribbed metal panels
 2. Other roof coverings as required

- F. Wall Covering
 - 1. Prefinished ribbed metal panels
 - 2. Other all coverings as required
 - 3. Natural Thin Stone Veneer as specified in Section 04 73 13. Installed by others.

- G. Insulation and Liner package
 - 1. Wall insulation
 - 2. Ceiling insulation
 - 3. Air deflectors
 - 4. Vapor retarder
 - 5. Wall stripping
 - 6. Prefinished ribbed metal panels

1.06 DESIGN REQUIREMENTS

- A. Roof Design Loads
 - 1. Top Chord Live Load: (30 PSF)
 - 2. Top Chord Dead Load: (4 PSF)
 - 3. Bottom Chord Dead Load: (2 PSF)
 - 4. Bottom Chord Point Loads: (NONE)
 - 5. Unbalanced Snow Loads: (NONE)

- B. Wind Speed
 - 1. 110 MPH (V3s). Exposure "B"
 - 2. Must meet or exceed the RI Building Code Basic Wind Speed requirements of 138 MPH for a Category II building.

- C. Roof and wall system shall be able to withstand the imposed loads with maximum allowable deflection of $L/180$.

- D. Assembly shall permit movement of components without buckling, failure of joint seals, undue stress on fasteners or other detrimental effects.

- E. Size and fabrication of wall and roof systems to be free of distortion or defects that would be detrimental to appearance or performance.

1.07 SUBMITTALS

- A. Submit under provisions of Section 01340.

- B. Provide four (4) sets of the following bearing the seal of a Professional Engineer, registered in the State of (Rhode Island)
 - 1. Complete and detailed shop and erection drawings showing size and location of each part and component, certifying that the building design meets specified roof and wind loading requirements
 - 2. Truss engineering analysis and design data, including the following:
 - a. Axial forces and bending moments for each member
 - b. Basic plate design value
 - c. Design analysis of each joint showing that proper plates have been applied
 - 3. Manufacturer's standard color chart

1.08 PROJECT RECORD DOCUMENTS

- A. Submit under provisions of Section 01 78 00.

1.09 QUALITY ASSURANCE

- A. Fabricate members in accordance with standard industry practice.

1.10 QUALIFICATIONS

- A. Contractor shall have a minimum of thirty years documented experience in the manufacture and erection of this type of structure.
- B. Design structural components under direct supervision of a Professional Engineer experienced in design of this work and licensed in the State of Rhode Island.
- C. Employ adequate numbers of skilled workmen who are thoroughly trained and experienced in the necessary crafts and who are completely familiar with the specified requirements and methods needed for proper and safe performance of the work.
- D. Contractor shall be responsible for all materials, whether furnished by themselves or a subcontractor, and proper storage of the same.

1.11 REGULATORY REQUIREMENTS

- A. Contractor shall be responsible for compliance with all applicable building codes and ordinances covering the work.
- B. Contractor shall cooperate with regulatory agencies or authorities to provide data as requested.

1.12 PRE-CONSTRUCTION MEETING

- A. The meeting will convene no later than one week prior to commencing work under provisions of Section 01 31 00.

1.13 FIELD MEASUREMENTS

- A. Field measurements shall be taken to verify that components match shop drawings.

1.14 DELIVERY, STORAGE AND HANDLING

- A. Deliver, store, protect and handle products to site under provisions of Section 01 60 00.
- B. Deliver and store prefabricated components (trusses, columns, steel panels and other items) so that they will not be damaged or deformed.
- C. Stack materials on platforms, pallets or other structures covered with tarpaulins or other suitable weather-tight ventilated covering. Handle and store structural parts in a manner

that will avoid deforming members or subjecting parts to excessive stresses.

- D. Panels shall not be stored in contact with other materials that may cause staining or discoloration. Store roofing and siding panels to allow water to drain freely.

1.15 PROJECT CONDITIONS

- A. Coordination
- B. Fit carpentry work to other work. Scribe and cope as required for accurate fitting.
- C. Correlate location of furring, nailers, blocking and supports to allow for attachment of other work.

1.16 CERTIFICATIONS

- A. In order for the bidder's proposal to be considered, the following certifications shall be tendered with the bid forms:
 - 1. Certification of the sheet steel supplier stating:
 - a. Minimum thickness of metallic coating steel in decimal inch
 - b. Identification of all metallic coatings
 - c. Coating weight range
 - d. Verification that material supplied is in conformance with applicable ASTM standard as stated in the technical specification
 - 2. Certification of paint supplier stating:
 - a. Generic chemistry of exterior side topcoat
 - b. Percentage of polyvinylidene difluoride (PVDF) in resin
 - 3. Certification of sheet steel coater stating:
 - a. Nominal paint film thickness in mils (one mil equals one thousandth of an inch)
 - 4. Certification of treated lumber stating:
 - a. Preservative type
 - b. Preservative retention in the wood (pounds per cubic foot of wood)
 - c. Depth of assay zone
 - d. Compliance of preservative and its retention in wood with AWWA or ICC-ES standards
 - 5. Warranty
 - a. Sample copy of warranty to be issued at completion of project
 - b. Verification that warranty meets or exceeds the requirements stated in the technical specification
- B. Failure to supply the required submittals will result in the bidder's proposal being rejected as non-responsive.

1.17 WARRANTY

- A. Provide warranties for the specified product under the provisions of Section 01 78 00.
- B. The building manufacturer shall supply a warranty to the Owner which shall provide that the manufacturer will:
 - 1. For a period of fifty (50) years:

- a. Absorb repair or replacement costs, including materials and labor, if any preservative treated lumber fails due to decay or insect attack
- b. Repair, or at its discretion, replace free of charge the building framework, including roofing and/or siding panels, if directly damaged by snow loads.
2. For a period of thirty-five (35) years:
 - a. Repaint any roofing or siding panel on which, under conditions of normal weather, the paint has separated from the panels due to flaking or peeling.
 - b. Repaint any roofing or siding panels on which, under conditions of normal weathering, chalking greater than a rating of 8 (ASTM D4212 Method 'A') or color change greater than five (5) units (ASTM D2244) has occurred.
3. For a period of ten (10) years:
 - a. Repaint any roofing or siding panel on which, under conditions of normal weather, exhibit corrosion resulting in red rust greater than 1/2 inch from any sheared edge which is clearly visible in casual observation.
4. For a period of five (5) years:
 - a. Repair, or at its discretion, replace free of charge the building framework, including roofing and/or siding panels, if directly damaged by wind loads, unless damage is caused by flying or falling objects.
 - b. Repair any roof leaks due to defects in materials or workmanship.
5. For a period of one (1) year:
 - a. Repair other building parts that prove to be defective in materials or workmanship.
6. The manufacturer shall not be liable for damage due to deterioration caused by interior chemical vapors and/or dust, deterioration from proximity to salt water body or aggressive exterior atmosphere, damage by flying or falling objects, or collateral damage to interior walls, ceiling, partitions, equipment and/or contents, or cost of preparation of the site.

PART 2 - PRODUCTS

2.01 MANUFACTURERS – BUILDING SYSTEM

- A. Morton Buildings, Inc., Morton, Illinois
- B. Substitutions: Under provisions of Section 01 60 00.

2.02 MATERIALS – FRAMING

- A. Columns
 1. Lower portion
 - a. Post frame building column consisting of a pre-cast concrete embedded portion with exposed rebar dowels for embedment in cast-in-place concrete footing, a wood upper portion, an internal steel bracket connection between wood and concrete, and a steel adjusting rod for post height adjustment.
 - b. Standards
 1. Building Code Requirements for Structural Concrete by the

- American Concrete Institute (ACI 318).
 2. Manual of Steel Construction, Load and Resistance Factor Design by The American Institute of Steel Construction (AISC).
 3. Concrete Column: 10,000 (Nominal) psi pre-cast self-consolidating concrete (SCC) with four (4) continuous vertical deformed Low-Alloy-Steel Reinforcing Bars of ASTM A706 weldable 60 ksi yield strength steel. Superplasticizers and polymer fiber reinforcement are added as well as other admixtures to increase freeze/thaw resistance, rust resistance, flexural and compressive strength as well as optimizing the hydration process.
 4. Adjusting Anchor Rod Assembly: 36 ksi thread rod and ASTM A 36 base plate.
 5. Internal Steel Bracket: ASTM A 572, Grade 50, steel bracket with 1/4" diameters holes for wood fastener screws.
2. Upper portion
 - a. Factory fabricated from minimum 3-ply No. 1 SYP
 - b. Attach upper column to lower column with appropriate number and size of pneumatically driven fasteners.
 - c. Provide factory or field installed blocking on outside face of column between nailers.
- B. Wood Trusses
The National Design Specification for Wood Construction (NDS) by The American Forest and Paper Association (AF&PA).
1. Lumber
 - a. Top Chord: Southern Yellow Pine of size and grade to meet design requirements
 - b. Bottom Chord: Southern Yellow Pine of size and grade to meet design requirements
 - c. Webs: Southern Yellow Pine of size and grade to meet design requirements
 2. Trusses shall be constructed of surfaced lumber (S4S) and compliant with SPIB visual and structural grade requirements
 3. Plates: Connector plates shall meet design requirements and shall be compliant with applicable ICC-ES standards and specifications
 4. Design and fabricate trusses and connections to withstand snow, wind and all dead loads.
 5. Fabricate trusses in plant, using mechanical or hydraulic fixtures as required to bring members into contact. Install plates in accordance with manufacturer's instructions.
- C. Baseboards
1. 2" x 8" No. 1 Southern Yellow Pine with 1/2" x 7/16" notch
 2. Pressure treated with wood preservative to a retention in compliance with applicable AWPA or ICC-ES standards and specifications and kiln dried after treatment to 19% maximum moisture content
 3. Preservative shall penetrate 100% of sapwood.
- D. Wall girts
1. First nailer (girt) above baseboard: 2" x 6" No. 2 or better Spruce-Pine-Fir (SPF)

- with 1/2" x 3/4" notch in bottom.
- 2. Balance of nailers: 2" x 4" 2100 MSR (minimum) SPF.
- 3. Overhang top nailer: 2" x 6" No. 2 or better SPF.

- E. Base reinforcement
 - 1. 7/16" x 32" OSB panels installed between the baseboard and first nailer and located in notches.

- F. Purlins and truss ties
 - 1. 2" x 4" No. 2 or better SPF

- G. Overhang framing
 - 1. Provide factory fabricated rafter frames.
 - 2. Provide 2" x 6" No. 2 or better SPF factory beveled fascia boards.

- H. Wind bracing
 - 1. 2" x 6" No. 2 or better SPF from endwall column to first truss back.

- I. Framing around openings
 - 1. 2" x 4" No. 2 or better SPF around personnel doors.
 - 2. 2" x 6" No. 2 or better SPF around overhead door openings

- J. Headers
 - 1. Provide built-up headers as required for proper installation.

- K. Incidental Framing
 - 1. 2" x 4" and/or 2" x 6" No. 2 or better SPF

- L. Interior framing
 - 1. 2" x 4" No. 2 or better SPF

2.03 MATERIALS – PREFINISHED METALS

- A. Roofing panels (Fluoroflex 1000®)
 - 1. Panel substrate shall be 0.019" minimum thickness commercial steel sheet with G90 (zinc) coating per ASTM A653 or AZ55 (aluminum/zinc) coating per ASTM A792.
 - 2. The weather side of the panel shall receive a nominal two tenths mil polyurethane primer and a nominal eight tenths mil topcoat of 70 % polyvinylidene difluoride (PVDF) resin to achieve a total nominal paint film thickness of one mil.
 - 3. Color selection of siding panels shall be from the manufacturer's standard color chart selected by the Architect.
 - 4. The non-weather side paint system shall consist of a two coat finish with a total nominal thickness of one-half mil.

- B. Siding Panels (Fluoroflex™ 1000)
 - 1. Panel substrate shall be 0.019" minimum thickness commercial steel sheet with G90 (zinc) coating per ASTM A653 or AZ55 (aluminum/zinc) coating per ASTM A792.
 - 2. The weather side of the panel shall receive a nominal two tenths mil polyurethane

- primer and a nominal eight tenths mil topcoat of 70% polyvinylidene difluoride (PVDF) resin to achieve a total nominal paint film thickness of one mil.
3. Color selection of siding panels shall be from the manufacturer's standard color chart selected by the Architect.
 4. The non-weather side paint system shall consist of a two coat finish with a total nominal thickness of one-half mil.

C. Wainscot Panels (Fluoroflex™ 1000)

1. Panel substrate shall be 0.019" minimum thickness commercial steel sheet with G90 (zinc) coating per ASTM A653 or AZ55 (aluminum/zinc) coating per ASTM A792.
2. The weather side of the panel shall receive a nominal two tenths mil polyurethane primer and a nominal eight tenths mil topcoat of 70% polyvinylidene difluoride (PVDF) resin to achieve a total nominal paint film thickness of one mil.
3. Color selection of siding panels shall be from the manufacturer's standard color chart selected by the Architect.
4. The non-weather side paint system shall consist of a two coat finish with a total nominal thickness of one-half mil.

D. Metal Trim Items (Fluoroflex™ 1000)

1. Die-formed steel from the same quality material as the siding panels

E. Interior Panels

1. Panel substrate shall be .019 minimum thick commercial steel sheet with a AZ50 (Galvalume) coating ASTM A792.
2. The interior-facing side of the panel shall receive a nominal two tenths mil acrylic primer and a nominal eight tenths mil top coat of white polyester paint to achieve a total nominal paint film thickness of one mil.
3. The hidden (backer) side paint system shall consist of a two coat finish with a total nominal thickness of one half mil.

2.04 MATERIALS – OTHER

A. Corner bracing

1. Provide 1-1/4" wide high tensile steel strapping in all unobstructed corners in an "X" configuration.

B. Roofing and siding fasteners

1. EPDM washered, painted, center drive stainless steel screws for ribbed steel panels

C. Closure strips

1. Closed cell foam.

D. Sealant

1. 100% neutral curing silicone sealant, and
2. paintable sealant where required

E. Insulation

1. Minimum 6" thick, R19 fiberglass blankets in wall

2. Minimum R38 blown-in fiberglass insulation in ceiling.
- F. Vapor Retarder
1. 4 mil. thick polyethylene sheets
- G. Exterior personnel doors to be galvanized steel insulated doors and frames as specified in Sections 08 12 13 and 08 13 13. See drawings for quantity and locations.
- H. Exterior personnel doors to be aluminum entrance doors and frames as noted on the drawings and as specified in Section 08 42 13. See drawings for quantity and locations.
- I. Include exterior wood barn doors as specified in Section 08 14 19. See drawings for quantity and locations.
- J. Windows:
1. 3'-0" wide x 3'-8" high fixed windows with Low-E insulated glass with Argon and grids between glass panes. See drawings for quantity and locations.
- K. Translucent roof skylight panels: See drawings for quantity, size and locations.
- 2.05 CONCRETE FOUNDATION
- A. Pre-engineered building Contractor is also responsible to provide concrete foundation as shown on drawings and specified.

PART 3 - EXECUTION

3.01 EXAMINATION

- A. Verify existing site conditions under provisions of Section 01 43 00.

3.02 ERECTION – FRAMING – GENERAL

- A. Erect framing in accordance with manufacturer's established construction procedures.
- B. Make all components and building plumb, square, straight and true to lines, according to industry standards (See Paragraph 3.05).
- C. Provide adequate temporary bracing to ensure structure remains plumb and square until permanent bracing is installed.
- D. Altering of structural members will not be permitted.

3.03 ERECTION – FRAMING

- A. Lower Column
1. Auger a hole to depth (48" minimum) with diameter as required by the building manufacturer.
 2. Accurate position lower column in the hole.
 3. Place ready-mix concrete in hole to footing size and thickness indicated on plans.
 4. Backfill with dry soil, compacted in 8" lifts

- B. Upper Column
 - 1. Set upper column to positive interlock with concrete lower column.
 - 2. Install manufacturer's recommend quantity and size pneumatically driven fasteners.

- C. Baseboards
 - 1. Install 2" x 8" treated plank, at grade, using builder's recommended fasteners.

- D. Wall girts
 - 1. Install 2" x 6" notched nailer to receive OSB panel.
 - 2. Install 2" x 4" nailers with on-center spacing as shown on building plans.
 - 3. Install 2" x 6" overhang nailer at the top.

- E. Trusses
 - 1. Set trusses in plane with the center member of the upper column using lifting methods as approved by the manufacturer.
 - 2. When properly positioned, install two 1/2" diameter machine bolts and manufacturer-recommended 20d ring shank nails through two of the upper column laminates and the truss heel.
 - 3. Brace trusses as recommended by the manufacturer.

- F. Purlins
 - 1. Install 2" x 4" purlins at 24" on-center (maximum) and attached to trusses with 60d ring shank nails.

- G. Wind bracing
 - 1. Install 2" x 6" angled bracing at locations recommended by the manufacturer.

- H. Incidental framing
 - 1. Install 2" x 4" or 2" x 6" blocking as required according to building manufacturer's recommendations.

- I. Interior framing
 - 1. Install 2" x 4" baseboard at 4" above grade and case in metal trims
 - 2. Install 2" x 4" horizontal stripping at 36" o.c. (max) in areas receiving ribbed steel panels
 - 3. Install 2" x 4" horizontal stripping at 16" o.c. in areas receiving gypsum board if applicable

3.04 ERECTION – PREFINISHED METALS – GENERAL

- A. Roofing Panels
 - 1. Install panels perpendicular to supports, aligned straight with end fascia
 - 2. Fasten panels to purlins with screw fasteners.

- B. Siding and wainscot panels
 - 1. Install panels perpendicular to supports, aligned level and plumb to industry standards (See 3.05).
 - 2. Fasten panels to wall girts with screw fasteners.
- C. Trim items
 - 1. Install trim items at the base, wainscot transition, corners, top of steel siding, fascia, gables and ridge using appropriate fasteners.
- D. Vent-A-Ridge
 - 1. Install over ridge trim using screw fasteners.
 - 2. Ensure that a minimum of 2" clear throat opening is maintained.
- E. Soffits
 - 1. Install soffits to interlock with trim items at top of steel siding and at fascia.
 - 2. Use solid soffit at end overhang.
 - 3. Use a combination of solid and perforated soffits to provide balanced ventilation at side overhangs.
- F. Gutter and downspouts
 - 1. Install gutters with spikes and ferrules (with washers) spaced 24" on-center.
 - 2. Silicone sealant and silicone rubber gaskets shall be used at laps to maintain leak prevention and to relieve stress due to thermal movement.
- G. Filler strips
 - 1. Provide closed cell foam filler strips at the top and bottom of the roofing panels.
- H. Interior Panels
 - 1. Install panels perpendicular to supports, aligned level and plumb
 - 2. Fasten panels to wall girts with 1" painted screws
 - 3. Fasten panels to lower truss chords with 1" painted screws

3.05 TOLERANCES

- A. Framing Members
 - 1. 1/4" from level.
 - 2. 1/8" from plumb
- B. Siding and roofing
 - 1. 1/8" from true position

3.06 CLEANING

- A. Clean under provisions of Section 01 70 00.

3.07 PROTECTION OF FINISHED WORK

- A. Protect finished product and work under provisions of Section 01 70 00.

END OF SECTION

SECTION 14 24 23

HYDRAULIC PASSENGER ELEVATORS

PART 1 GENERAL

1.01 SUMMARY

- A. Section includes: Hydraulic passenger elevators as shown and specified. Elevator work includes:
1. Standard pre-engineered hydraulic passenger elevators.
 2. Elevator car enclosures, hoistway entrances and signal equipment.
 3. Operation and control systems.
 4. Jack(s).
 5. Accessibility provisions for physically disabled persons.
 6. Equipment, machines, controls, systems and devices as required for safely operating the specified elevators at their rated speed and capacity.
 7. Materials and accessories as required to complete the elevator installation.
- B. Related Sections:
1. Division 1 General Requirements: Meet or exceed all referenced sustainability requirements.
 2. Division 3 Concrete: Installing inserts, sleeves and anchors in concrete.
 3. Division 4 Masonry: Installing inserts, sleeves and anchors in masonry.
 4. Division 5 Metals:
 - a. Providing hoist beams, pit ladders, steel framing, auxiliary support steel and divider beams for supporting guide-rail brackets.
 - b. Providing steel angle sill supports and grouting hoistway entrance sills and frames.
 5. Division 9 Finishes: Providing elevator car finish flooring and field painting unfinished and shop primed ferrous materials.
 6. Division 22 Plumbing
 - a. Sump pit and oil interceptor.
 7. Division 23 Heating, Ventilation and Air Conditioning
 - a. Heating and ventilating hoistways and/or control room.
 8. Division 26 Sections:
 - a. Providing electrical service to elevators, including fused disconnect switches.
 - b. Emergency power supply, transfer switch and auxiliary contacts.
 - c. Heat and smoke sensing devices.
 - d. Convenience outlets and illumination in control room, hoistway and pit.
- C. Work Not Included: General contractor shall provide the following in accordance with the requirements of the Model Building Code and ANSI A17.1 Code. For specific rules, refer to ANSI A17.1, Part 3 for hydraulic elevators. State or local requirements must be used if more stringent. The cost of this work is not included in the TK Elevator's proposal, since it is a part of the building construction.

1. Elevator hoist beam to be provided at top of elevator shaft. Beam must be able to accommodate proper loads and clearances for elevator installation and operation.
2. Supply in ample time for installation by other trades, inserts, anchors, bearing plates, brackets, supports and bracing including all setting templates and diagrams for placement.
3. Hatch walls require a minimum two hours of fire rating. Hoistway should be clear and plumb with variations not to exceed 1/2" at any point.
4. Elevator hoistways shall have barricades, as required.
5. Install bevel guards at 75° on all recesses, projections or setbacks over 2" (4" for A17.1 2000 areas) except for loading or unloading.
6. Provide rail bracket supports at pit, each floor and roof. For guide rail bracket supports, provide divider beams between hoistway at each floor and roof.
7. Pit floor shall be level and free of debris. Reinforce dry pit to sustain normal vertical forces from rails and buffers.
8. Where pit access is by means of the lowest hoistway entrance, a vertical ladder of non-combustible material extending 42" minimum, (48" minimum for A17.1-2000 areas) shall be provided at the same height, above sill of access door or handgrips.
9. Machine room to be enclosed and protected.
10. Machine Room temperature must be maintained between 55° and 90° F.
11. If machine room is remote from the elevator hoistway, clear access must be available above the ceiling or metal/concrete raceways in floor for oil line and wiring duct from machine room.
12. Access to the machinery space and machine room must be in accordance with the governing authority or code.
13. Provide an 8" x 16" cutout through machine room wall, for oil line and wiring duct, coordinated with elevator contractor at the building site.
14. All wire and conduit should run remote from the hoistways.
15. When heat, smoke or combustion sensing devices are required, connect to elevator control cabinet terminals. Contacts on the sensors should be sided for 12 volt D.C.
16. Install and furnish finished flooring in elevator cab.
17. Finished floors and entrance walls are not to be constructed until after sills and door frames are in place. Consult elevator contractor for rough opening size. The general contractor shall supply the drywall framing so that the wall fire resistance rating is maintained, when drywall construction is used.
18. Where sheet rock or drywall construction is used for front walls, it shall be of sufficient strength to maintain the doors in true lateral alignment. Drywall contractor to coordinate with elevator contractor.
19. Before erection of rough walls and doors; erect hoistway sills, headers, and frames. After rough walls are finished; erect fascias and toe guards. Set sill level and slightly above finished floor at landings.
20. To maintain legal fire rating (masonry construction), door frames are to be anchored to walls and properly grouted in place.
21. The elevator wall shall interface with the hoistway entrance assembly and be in strict compliance with the elevator contractor's requirements.

22. General Contractor shall fill and grout around entrances, as required.
23. Elevator sill supports shall be provided at each opening.
24. All walls and sill supports must be plumb where openings occur.
25. For applications with jack hole, free and clear access to the elevator pit area for the jack hole-drilling rig is required.
26. Where jack hole is required, remove all spoils from jack hole drilling.
27. When not provided by Elevator Contractor, jack hole shall accommodate the jack unit. If required the jack hole is to be provided in strict accordance with the elevator contractor's shop drawings.
28. Locate a light fixture (200 lx / 19 fc) and convenience outlet in pit with switch located adjacent to the access door.
29. A light switch and fused disconnect switch for each elevator should be located inside the machine room adjacent to the door, where practical, per the National Electrical Code (NFPA No. 70).
30. For signal systems and power operated door: provide ground and branch wiring circuits, including main line switch.
31. For car light and fan: provide a feeder and branch wiring circuits, including main line switch.
32. Wall thickness may increase when fixtures are mounted in drywall. These requirements must be coordinated between the general contractor and the elevator contractor.
33. Provide supports, patching and recesses to accommodate hall button boxes, signal fixtures, etc..
34. Locate telephone and convenience outlet on control panel.

1.02 SUBMITTALS

- A. Submit under provisions of Section 01 33 00.
- B. Product data: When requested, the elevator contractor shall provide standard cab, entrance and signal fixture data to describe product for approval.
- C. Shop drawings:
 1. Show equipment arrangement in the corridor, pit, and hoistway and/or optional control room. Provide plans, elevations, sections and details of assembly, erection, anchorage, and equipment location.
 2. Indicate elevator system capacities, sizes, performances, safety features, finishes and other pertinent information.
 3. Show floors served, travel distances, maximum loads imposed on the building structure at points of support and all similar considerations of the elevator work.
 4. Indicate electrical power requirements and branch circuit protection device recommendations.
- D. Powder Coat paint selection: Submit manufacturer's standard selection charts for exposed finishes and materials.

- E. Plastic laminate selection: Submit manufacturer's standard selection charts for exposed finishes and materials.
- F. Metal Finishes: Upon request, standard metal samples provided.
- G. Operation and maintenance data. Include the following:
 - 1. Owner's manuals and wiring diagrams.
 - 2. Parts list, with recommended parts inventory.

1.03 QUALITY ASSURANCE

- A. Manufacturer Qualifications: An approved manufacturer with minimum 15 years of experience in manufacturing, installing, and servicing elevators of the type required for the project.
 - 1. The manufacturer of machines, controllers, signal fixtures, door operators cabs, entrances, and all other major parts of elevator operating equipment.
 - a. The major parts of the elevator equipment shall be manufactured by the installing company, and not be an assembled system.
 - 2. The manufacturer shall have a documented, on-going quality assurance program.
 - 3. ISO-9001:2000 Manufacturer Certified
 - 4. ISO-14001:2004 Environmental Management System Certified
- B. Installer Qualifications: The manufacturer or an authorized agent of the manufacturer with not less than 15 years of satisfactory experience installing elevators equal in character and performance to the project elevators.
- C. Regulatory Requirements:
 - 1. ASME A17.1 Safety Code for Elevators and Escalators, latest edition or as required by the local building code.
 - 2. Building Code: National.
 - 3. NFPA 70 National Electrical Code.
 - 4. NFPA 80 Fire Doors and Windows.
 - 5. Americans with Disabilities Act - Accessibility Guidelines (ADAAG)
 - 6. Section 407 in ICC A117.1, when required by local authorities
- D. Fire-rated entrance assemblies: Opening protective assemblies including frames, hardware, and operation shall comply with ASTM E2074, CAN4-S104 (ULC-S104), UL10(b), and NFPA Standard 80. Provide entrance assembly units bearing Class B or 1 1/2 hour label by a Nationally Recognized Testing Laboratory (2 hour label in Canada).
- E. Inspection and testing:
 - 1. Elevator Installer shall obtain and pay for all required inspections, tests, permits and fees for elevator installation.
 - 2. Arrange for inspections and make required tests.
 - 3. Deliver to the Owner upon completion and acceptance of elevator work.

1.04 DELIVERY, STORAGE AND HANDLING

- A. Deliver, store, protect and handle products to site under provisions of Section 01 60 00.
- B. Manufacturing shall deliver elevator materials, components and equipment and the contractor is responsible to provide secure and safe storage on job site.

1.05 PROJECT CONDITIONS

- A. Temporary Use: Elevators shall not be used for temporary service or for any other purpose during the construction period before Substantial Completion and acceptance by the purchaser unless agreed upon by Elevator Contractor and General Contractor with signed temporary agreement.

1.06 WARRANTY

- A. Warranty: Submit elevator manufacturer's standard written warranty agreeing to repair, restore or replace defects in elevator work materials and workmanship not due to ordinary wear and tear or improper use or care for 12 months after final acceptance.

1.07 MAINTENANCE

- A. Furnish maintenance and call back service for a period of 12 months for each elevator after completion of installation or acceptance thereof by beneficial use, whichever is earlier, during normal working hours excluding callbacks.
 - 1. Service shall consist of periodic examination of the equipment, adjustment, lubrication, cleaning, supplies and parts to keep the elevators in proper operation. Maintenance work, including emergency call back repair service, shall be performed by trained employees of the elevator contractor during regular working hours.
 - 2. Submit parts catalog and show evidence of local parts inventory with complete list of recommended spare parts. Parts shall be produced by manufacturer of original equipment.
 - 3. Manufacturer shall have a service office and full time service personnel within a 100 mile radius of the project site.

PART 2 PRODUCTS

2.01 MANUFACTURERS

- A. Manufacturer: Design based around TK Elevator's endura hydraulic elevator.
- B. Substitutions: Under provisions of Section 01 60 00.

2.02 MATERIALS, GENERAL

- A. All Elevator Cab materials including frame, buttons, lighting, wall and ceiling assembly, laminates and carpet shall have an Environmental Product Declarations (EPD) and a Health Product Declaration (HPD).

- B. Colors, patterns, and finishes: As selected by the Architect from manufacturer's full range of standard colors, patterns, and finishes.
- C. Steel:
 - 1. Shapes and bars: Carbon.
 - 2. Sheet: Cold-rolled steel sheet, commercial quality, Class 1, matte finish.
 - 3. Finish: Factory-applied baked enamel for structural parts, powder coat for architectural parts. Color selection must be based on elevator manufacture's standard selections.
- D. Plastic laminate: Decorative high-pressure type, complying with NEMA LD3, Type GP-50 General Purpose Grade, nominal 0.050" thickness. Laminate selection must be based on elevator manufacture's standard selections.
- E. Flooring to be RUB2 as specified in Section 09 65 00 – Resilient Flooring.

2.03 HOISTWAY EQUIPMENT

- A. Platform: Fabricated frame of formed or structural steel shapes, gusseted and rigidly welded with a wood sub-floor. Underside of the platform shall be fireproofed. The car platform shall be designed and fabricated to support one-piece loads weighing up to 25% of the rated capacity.
- B. Sling: Steel stiles bolted or welded to a steel crosshead and bolstered with bracing members to remove strain from the car enclosure.
- C. Guide Rails: Steel, omega shaped, fastened to the building structure with steel brackets.
- D. Guides: Slide guides shall be mounted on top and bottom of the car.
- E. Buffers: Provide substantial buffers in the elevator pit. Mount buffers on continuous channels fastened to the elevator guide rail or securely anchored to the pit floor. Provide extensions if required by project conditions.
- F. Jack: A jack unit shall be of sufficient size to lift the gross load the height specified. Factory test jack to ensure adequate strength and freedom from leakage. Brittle material, such as gray cast iron, is prohibited in the jack construction. Provide the following jack type: Twin post holeless. Two jacks piped together, mounted one on each side of the car with a polished steel hydraulic plunger housed in a sealed steel casing having sufficient clearance space to allow for alignment during installation. Each plunger shall have a high pressure sealing system which will not allow for seal movement or displacement during the course of operation. Each Jack Assembly shall have a check valve built into the assembly to allow for automatically re-syncing the two plunger sections by moving the jack to its fully contracted position. The jack shall be designed to be mounted on the pit floor or in a recess in the pit floor. Each jack section shall have a bleeder valve to discharge any air trapped in the section..

- G. Automatic Self-Leveling: Provide each elevator car with a self-leveling feature to automatically bring the car to the floor landings and correct for over travel or under travel. Self-leveling shall, within its zone, be automatic and independent of the operating device. The car shall be maintained approximately level with the landing irrespective of its load.
- H. Wiring, Piping, and Oil: Provide all necessary hoistway wiring in accordance with the National Electrical Code. All necessary code compliant pipe and fittings shall be provided to connect the power unit to the jack unit. Provide proper grade inherently biodegradable oil as specified by the manufacturer of the power unit (see Power Unit section 2.04.G for further details)

2.04 POWER UNIT

- A. Power Unit (Oil Pumping and Control Mechanism): A self-contained unit consisting of the following items:
 - 1. An oil reservoir with tank cover.
 - 2. An oil hydraulic pump.
 - 3. An electric motor.
 - 4. An oil control valve with the following components built into single housing; high pressure relief valve, check valve, automatic unloading up start valve, lowering and leveling valve, and electro-magnetic controlling solenoids.
- B. Pump: Positive displacement type pump specifically manufactured for oil-hydraulic elevator service. Pump shall be designed for steady discharge with minimum pulsation to give smooth and quiet operation. Output of pump shall not vary more than 10 percent between no load and full load on the elevator car.
- C. Motor: Standard manufacture motor specifically designed for oil-hydraulic elevator service. Duty rating shall be selected for specified speed and load.
- D. Oil Control Unit: The following components shall be built into a single housing. Welded manifolds with separate valves to accomplish each function are not acceptable. Adjustments shall be accessible and be made without removing the assembly from the oil line.
 - 1. Relief valve shall be adjustable and be capable of bypassing the total oil flow without increasing back pressure more than 10 percent above that required to barely open the valve.
 - 2. Up start and stop valve shall be adjustable and designed to bypass oil flow during start and stop of motor pump assembly. Valve shall close slowly, gradually diverting oil to or from the jack unit, ensuring smooth up starts and up stops.
 - 3. Check valve shall be designed to close quietly without permitting any perceptible reverse flow.
 - 4. Lowering valve and leveling valve shall be adjustable for down start speed, lowering speed, leveling speed and stopping speed to ensure smooth "down" starts and stops. The leveling valve shall be designed to level the car to the floor in the direction the car is traveling after slowdown is initiated.

5. Provided with constant speed regulation in both up and down direction. Feature to compensate for load changes, oil temperature, and viscosity changes.
6. Solid State Starting: Provide an electronic starter featuring adjustable starting currents.
7. Oil Type: Provide a zinc free, inherently biodegradable lubricant formulated with premium base stocks to provide outstanding protection for demanding hydraulic systems, especially those operating in environmentally sensitive areas.

2.05 HOISTWAY ENTRANCES

- A. Doors and Frames: Provide complete hollow metal type hoistway entrances at each hoistway opening bolted\knock down construction.
 1. Manufacturer's standard entrance design consisting of hangers, doors, hanger supports, hanger covers, fascia plates (where required), sight guards, and necessary hardware.
 2. Main landing door & frame finish: Stainless steel panels, no. 4 brushed finish with no. 4 brushed finish entrance frame.
 3. Typical door & frame finish: Stainless steel panels, no. 4 brushed finish with no. 4 brushed finish entrance frame.
- B. Interlocks: Equip each hoistway entrance with an approved type interlock tested as required by code. Provide door restriction devices as required by code.
- C. Door Hanger and Tracks: Provide sheave type two point suspension hangers and tracks for each hoistway horizontal sliding door.
 1. Sheaves: Polyurethane tires with ball bearings properly sealed to retain grease.
 2. Hangers: Provide an adjustable device beneath the track to limit the up-thrust of the doors during operation.
 3. Tracks: Drawn steel shapes, smooth surface and shaped to conform to the hanger sheaves.
- D. Hoistway Sills: Extruded metal, with groove(s) in top surface. Provide mill finish on aluminum.

2.06 PASSENGER ELEVATOR CAR ENCLOSURE

- A. Car Enclosure:
 1. Walls: Cab type TKAP, reinforced cold-rolled steel with two coats factory applied baked enamel finish, with applied vertical wood core panels covered on both sides with high pressure plastic laminate.
 2. Reveals and frieze: Stainless steel, no. 4 brushed finish
 3. Canopy: Cold-rolled steel with hinged exit.
 4. Ceiling: Suspended type, LED lighting with translucent diffuser mounted in a metal frame. Framework shall be finished with a stainless steel, no. 4 brushed finish.
 5. Cab Fronts, Return, Transom, Soffit and Strike: Provide panels faced with brushed stainless steel

6. Doors: Horizontal sliding car doors reinforced with steel for panel rigidity. Hang doors on sheave type hangers with polyurethane tires that roll on a polished steel track and are guided at the bottom by non-metallic sliding guides.
 - a. Door Finish: Stainless steel panels: No. 4 brushed finish.
 - b. Cab Sills: Extruded aluminum, mill finish.
 7. Handrail: Provide 1.5' diameter cylindrical metal on side walls only on front and rear opening cars. Handrails shall have a stainless steel, no. 4 brushed finish.
 8. Ventilation: Manufacturer's standard exhaust fan, mounted on the car top.
 9. Protection pads and buttons: Not required
- B. Car Top Inspection: Provide a car top inspection station with an "Auto-Inspection" switch, an "emergency stop" switch, and constant pressure "up and down" direction and safety buttons to make the normal operating devices inoperative. The station shall give the inspector complete control of the elevator. The car top inspection station shall be mounted in the door operator assembly.

2.07 DOOR OPERATION

- A. Door Operation: Provide a direct or alternating current motor driven heavy duty operator designed to operate the car and hoistway doors simultaneously. The door control system shall be digital closed loop and the closed loop circuit shall give constant feedback on the position and velocity of the elevator door. The motor torque shall be constantly adjusted to maintain the correct door speed based on its position and load. All adjustments and setup shall be through the computer based service tool. Door movements shall follow a field programmable speed pattern with smooth acceleration and deceleration at the ends of travel. The mechanical door operating mechanism shall be arranged for manual operation in event of power failure. Doors shall automatically open when the car arrives at the landing and automatically close after an adjustable time interval or when the car is dispatched to another landing. AC controlled units with oil checks, or other deviations are not acceptable.
1. No Un-Necessary Door Operation: The car door shall open only if the car is stopping for a car or hall call, answering a car or hall call at the present position or selected as a dispatch car.
 2. Door Open Time Saver: If a car is stopping in response to a car call assignment only (no coincident hall call), the current door hold open time is changed to a shorter field programmable time when the electronic door protection device is activated.
 3. Double Door Operation: When a car stops at a landing with concurrent up and down hall calls, no car calls, and no other hall call assignments, the car door opens to answer the hall call in the direction of the car's current travel. If an onward car call is not registered before the door closes to within 6 inches of fully closed, the travel shall reverse and the door shall reopen to answer the other call.
 4. Nudging Operation: The doors shall remain open as long as the electronic detector senses the presence of a passenger or object in the door opening. If door closing is prevented for a field programmable time, a buzzer shall sound. When the obstruction is removed, the door shall begin to close at reduced speed. If the infra-red door protection system detects

a person or object while closing on nudging, the doors shall stop and resume closing only after the obstruction has been removed.

5. Door Reversal: If the doors are closing and the infra-red beam(s) is interrupted, the doors shall reverse and reopen. After the obstruction is cleared, the doors shall begin to close.
 6. Door Open Watchdog: If the doors are opening, but do not fully open after a field adjustable time, the doors shall recycle closed then attempt to open six times to try and correct the fault.
 7. Door Close Watchdog: If the doors are closing, but do not fully close after a field adjustable time, the doors shall recycle open then attempt to close six times to try and correct the fault.
 8. Door Close Assist: When the doors have failed to fully close and are in the recycle mode, the door drive motor shall have increased torque applied to possibly overcome mechanical resistance or differential air pressure and allow the door to close.
- B. Door Protection Device: Provide a door protection system using microprocessor controlled infra-red light beams. The beams shall project across the car opening detecting the presence of a passenger or object. If door movement is obstructed, the doors shall immediately reopen.

2.08 CAR OPERATING STATION

- A. Car Operating Station, General: The main car control in each car shall contain the devices required for specific operation mounted in an integral swing return panel requiring no applied faceplate. Wrap return shall have a brushed stainless steel finish. The main car operating panel shall be mounted in the return and comply with handicap requirements. Pushbuttons that illuminate using long lasting LED's shall be included for each floor served, and emergency buttons and switches shall be provided per code. Switches for car light and accessories shall be provided.
- B. Emergency Communications System: Integral phone system provided.
- C. Auxiliary Operating Panel: Not Required
- D. Column Mounted Car Riding Lantern: A car riding lantern shall be installed in the elevator cab and located in the entrance. The lantern, when illuminated, will indicate the intended direction of travel. The lantern will illuminate and a signal will sound when the car arrives at a floor where it will stop. The lantern shall remain illuminated until the door(s) begin to close.
- E. Special Equipment: Not Applicable
- F. Digital Services: Cloud-based IoT monitoring system comes standard with these options:
Remote Monitoring with Application Programming Interface (API) Integration
ADA Phone - Code Compliant Cellular Connectivity
A17.1 2019 Code - Enhanced Communications

2.09 CONTROL SYSTEMS

- A. Controller: The elevator control system shall be microprocessor based and software oriented. Control of the elevator shall be automatic in operation by means of push buttons in the car numbered to correspond to floors served, for registering car stops, and by "up-down" push buttons at each intermediate landing and "call" push buttons at terminal landings.
- B. Automatic Light and Fan shut down: The control system shall evaluate the system activity and automatically turn off the cab lighting and ventilation fan during periods of inactivity. The settings shall be field programmable.
- C. Emergency Power Operation: Full automatic operation (Simplex 10D-4A) Upon loss of the normal power supply, building-supplied standby power is available to the elevator on the same wires as the normal power. Once the loss of normal power has been detected and standby power is available, the elevator is lowered to a pre-designated landing and will open the doors. After passengers have exited the elevator, the doors are closed. At this time the elevator is automatically allowed to continue service using the building-supplied standby power.
- D. Special Operation: Not Applicable
- E. Digital Services:

Cloud-based IoT Monitoring System (standard): Contractor shall provide a cloud-based IoT (internet of things) monitoring system capable of tracking door movements and timing, trips, power cycles, car calls, out-of-service events and modes. This observation will continue 24/7 and it shall be capable of providing service technicians a minimum of three recommended solutions for defined failure events and automatically dispatch service technicians in the event of failure(s) while sending notifications to end users of changes in their equipment's state via both email and mobile device. Access to IoT and related equipment data and status will be made available in both a web portal and mobile application secured by password and username with at least two-factor authentication. Finally, this system must be self-contained and not require internet provision by others.

Along with the monitoring system, options are available.

Remote Monitoring with Application Programming Interface (API) Integration: Contractor shall provide a portal and mobile device application (app) that communicates relevant service and operational information such as elevator operational status, open service call tickets, call ticket history and performance and service history. This system shall provide a REST application programming interface (API) capable of transmitting relevant information from the cloud-based IoT monitoring system. This data includes equipment operational status, door movements, service and maintenance history, traffic statistics and failure alerts.

ADA Phone – Code Compliant Cellular Connectivity: Contractor shall provide a phone service through a self-contained cellular based VoIP system. This system shall meet code, include a backup battery capable of powering the emergency communication equipment for 4+ hours in the event of a power outage. The solution shall have remote monitoring capability to ensure continuous connectivity with a means of remote troubleshooting. Remote monitoring capability shall include, at a minimum, the ability to monitor connectivity and power supply. Remote monitoring shall be capable of providing local alerts to response personnel when on-site intervention is required.

A17.1 2019 Code – Enhanced Communications: For jobs installed under enforcement of 2018 International Building Code or ASME A17.1-2019/CSA B44:19 Safety Code, contractor will provide a video camera necessary for viewing the elevator cab interior floor as well as a position indicator display in the cab operating panel capable of providing means of two-way, text-based communication when the emergency call button is engaged in the elevator car. These components, and associated cloud-based monitoring platform, will be non-proprietary in nature, allowing customization on where to direct emergency calls, while offering capability for any party to provide the emergency monitoring services.

2.10 HALL STATIONS

- A. Hall Stations, General: Vandal resistant buttons with center jewels which illuminate to indicate that a call has been registered at that floor for the indicated direction. Each button shall be provided with an internal automatic stop to prevent damage of switches that register the call. Provide 1 set of pushbutton risers. All fixtures shall be vandal resistant type.
 - 1. Provide one pushbutton riser with faceplates having a brushed stainless steel finish.
 - a. Phase 1 firefighter’s service key switch, with instructions, shall be incorporated into the hall station at the designated level.
- B. Floor Identification Pads: Provide door jamb pads at each floor. Jamb pads shall comply with Americans with Disabilities Act (ADA) requirements.
- C. Hall Position Indicator: Not Applicable
- D. Hall lanterns: Not Applicable
- E. Special Equipment: Not Applicable

2.11 MISCELLANEOUS ELEVATOR COMPONENTS

- A. Oil Hydraulic Silencer: Install multiple oil hydraulic silencers (muffler device) at the power unit location. The silencers shall contain pulsation absorbing material inserted in a blowout proof housing.

PART 3 EXECUTION

3.01 EXAMINATION

- A. Before starting elevator installation, inspect hoistway, hoistway openings, pits and/or control room, as constructed, verify all critical dimensions, and examine supporting structures and all other conditions under which elevator work is to be installed. Do not proceed with elevator installation until unsatisfactory conditions have been corrected in a manner acceptable to the installer.
- B. Installation constitutes acceptance of existing conditions and responsibility for satisfactory performance.

3.02 INSTALLATION

- A. Install elevator systems components and coordinate installation of hoistway wall construction.
 - 1. Work shall be performed by competent elevator installation personnel in accordance with ASME A17.1, manufacturer's installation instructions and approved shop drawings.
 - 2. Comply with the National Electrical Code for electrical work required during installation.
- B. Jack unit excavation (if required by the type of jack provided): Drill or otherwise excavate below elevator pit construction as required to install the jack unit.
 - 1. Install casing for jack unit.
 - 2. Provide HDPE jack protection system for all in ground jacks.
 - 3. Set casing for jack unit assembly plumb, and partially fill with water settled sand, eliminating voids. Back fill depth shall be sufficient to hold the bottom of the jack in place over time.
- C. Perform work with competent, skilled workmen under the direct control and supervision of the elevator manufacturer's experienced foreman.
- D. Supply in ample time for installation by other trades, inserts, anchors, bearing plates, brackets, supports, and bracing including all setting templates and diagrams for placement.
- E. Welded construction: Provide welded connections for installation of elevator work where bolted connections are not required for subsequent removal or for normal operation, adjustment, inspection, maintenance, and replacement of worn parts. Comply with AWS standards for workmanship and for qualification of welding operators.
- F. Coordination: Coordinate elevator work with the work of other trades, for proper time and sequence to avoid construction delays. Use benchmarks, lines, and levels designated by the Contractor, to ensure dimensional coordination of the work.

- G. Install machinery, guides, controls, car and all equipment and accessories to provide a quiet, smoothly operating installation, free from side sway, oscillation or vibration.
- H. Alignment: Coordinate installation of hoistway entrances with installation of elevator guide rails for accurate alignment of entrances with cars. Where possible, delay final adjustment of sills and doors until car is operable in shaft. Reduce clearances to minimum safe, workable dimensions at each landing.
- I. Erect hoistway sills, headers, and frames before erection of rough walls and doors; erect fascia and toe guards after rough walls finished. Set sill units accurately aligned and slightly above finish floor at landings.
- J. Lubricate operating parts of system, where recommended by manufacturer.

3.03 FIELD QUALITY CONTROL

- A. Acceptance testing: Upon completion of the elevator installation and before permitting use of elevator, perform acceptance tests as required and recommended by Code and governing regulations or agencies. Perform other tests, if any, as required by governing regulations or agencies.
- B. Advise Owner, Contractor, Architect, and governing authorities in advance of dates and times tests are to be performed on the elevator.

3.04 ADJUSTING

- A. Make necessary adjustments of operating devices and equipment to ensure elevator operates smoothly and accurately.

3.05 CLEANING

- A. Before final acceptance, remove protection from finished surfaces and clean and polish surfaces in accordance with manufacturer's recommendations for type of material and finish provided. Stainless steel shall be cleaned with soap and water and dried with a non-abrasive surface; it shall not be cleaned with bleach-based cleansers.
- B. At completion of elevator work, remove tools, equipment, and surplus materials from site. Clean equipment rooms and hoistway. Remove trash and debris.
 - 1. Use environmentally preferable and low VOC emitting cleaners for each application type. Cleaners that contain solvents, pine and/or citrus oils are not permitted.

3.06 PROTECTION

- A. At time of Substantial Completion of elevator work, or portion thereof, provide suitable protective coverings, barriers, devices, signs, or other such methods or procedures to protect elevator work from damage or deterioration. Maintain protective measures throughout remainder of construction period.

3.07 DEMONSTRATION

- A. Instruct Owner's personnel in proper use, operations, and daily maintenance of elevators. Review emergency provisions, including emergency access and procedures to be followed at time of failure in operation and other building emergencies. Train Owner's personnel in normal procedures to be followed in checking for sources of operational failures or malfunctions.
- B. Make a final check of each elevator operation, with Owner's personnel present, immediately before date of substantial completion. Determine that control systems and operating devices are functioning properly.

3.08 ELEVATOR SCHEDULE

- A. Elevator Qty. 1
 - 1. Elevator Model: endura Twinpost above-ground 1-stage
 - 2. Elevator Type: Hydraulic Passenger
 - 3. Rated Capacity: 2100 lbs.
 - 4. Rated Speed: 110 ft./min.
 - 5. Operation System: TAC32H
 - 6. Travel: 12'-0"
 - 7. Landings: 2 total
 - 8. Openings:
 - a. Front: 1
 - b. Rear: 1
 - 9. Clear Car Inside: 5'-8" wide x 4'-3 1/2" deep
 - 10. Inside clear height: 7'-4" standard
 - 11. Door clear height: 7'-0" standard
 - 12. Hoistway Entrance Size: 3'-0" wide x 7'-0" high
 - 13. Door Type: One-speed | RH Side opening
 - 14. Power Characteristics: 230 volts, 3 Phase, 60 Hz.
 - 15. Seismic Requirements: Zone 1
 - 16. Hoistway Dimensions: 7'-4" wide x 6'-8 3/4" deep
 - 17. Pit Depth: 4'-0"
 - 18. Button & Fixture Style: Vandal Resistant Signal Fixtures
 - 19. Fire Service Floor level: Upper Level floor
 - 20. Special Operations: None
 - 21. Digital Services:
 - a. Remote Monitoring with Application Programming Interface (API) Integration
 - b. ADA Phone - Code Compliant Cellular Connectivity
 - c. A17.1 2019 Code - Enhanced Communications

END OF SECTION

THIS PAGE INTENTIONALLY LEFT BLANK

SECTION 14 42 16

VERTICAL PLATFORM WHEELCHAIR LIFT

PART 1 GENERAL

1.1 SECTION INCLUDES

- A. Vertical platform wheelchair lift installed within shaftway.

1.2 RELATED SECTIONS

- A. Section 03 30 00 - Cast-In-Place Concrete: Anchor placement.
- B. Section 06 10 00 - Rough Carpentry: Blocking in framed construction for lift attachment.
- C. Section 09 21 16 - Gypsum Board Assemblies: Gypsum board shaftway.
- D. Division 26 - Electrical: Lighting and wiring connections at top of shaft.
- E. Division 26 - Electrical: Electrical power service and wiring connections.

1.3 REFERENCES

- A. ASME A17.1 - Safety Code for Elevators and Escalators.
- B. ASME A17.5 - Elevator and Escalator Electrical Equipment.
- C. ASME A18.1 - Safety Standard for Platform Lifts and Stairway Chairlifts.
- D. ICC/ANSI A117.1 - Accessible and Usable Buildings and Facilities.
- E. NFPA 70 - National Electric Code.

1.4 SUBMITTALS

- A. Submit under provisions of Section 01 30 00.
- B. Product Data: Manufacturer's data sheets on each product to be used, including:
 - 1. Submit manufacturer's installation instructions, including preparation, storage and handling requirements.
 - 2. Include complete description of performance and operating characteristics.
 - 3. Show maximum and average power demands.

- C. Shop Drawings:
 - 1. Show typical details of assembly, erection and anchorage.
 - 2. Include wiring diagrams for power, control, and signal systems.
 - 3. Show complete layout and location of equipment, including required clearances and coordination with shaftway.
- D. Selection Samples: For each finished product specified, provide two complete sets of color chips representing manufacturer's full range of available colors and patterns.
- E. Verification Samples: For each finished product specified, two samples, minimum size 1-3/4" x 2-1/4", representing actual product, color, and patterns.

1.5 QUALITY ASSURANCE

- A. Manufacturer Qualifications: Firm with minimum 20 year's experience in manufacturing of vertical platform wheelchair lifts, with evidence of experience with similar installations of type specified.
- B. Installer Qualifications: Licensed to install equipment of this scope, with evidence of experience with specified equipment. Installer shall maintain an adequate stock of replacement parts, have qualified people available to ensure fulfillment of maintenance and callback service without unreasonable loss of time in reaching project site.

1.6 REGULATORY REQUIREMENTS

- A. Provide platform lifts in compliance with:
 - 1. ASME A18.1 - Safety Standard for Platform Lifts and Stairway Chairlifts.
 - 2. ASME A17.1 - Safety Code for Elevators and Escalators.
 - 3. ASME A17.5 - Elevator and Escalator Electrical Equipment.
 - 4. NFPA 70 - National Electric Code.

1.7 DELIVERY, STORAGE, AND HANDLING

- A. Store products in manufacturer's unopened packaging until ready for installation.
- B. Store components off the ground in a dry covered area, protected from adverse weather conditions.

1.8 PROJECT CONDITIONS

- A. Do not use wheelchair lift for hoisting materials or personnel during construction period.

1.9 WARRANTY

- A. Warranty: Manufacturer shall warrant the wheelchair lift materials and factory workmanship for two (2) years following completion of installation.

PART 2 PRODUCTS

2.1 MANUFACTURERS

- A. Acceptable Manufacturer: Garaventa Lift;
United States - P.O. Box 1769, Blaine, WA 98231-1769.
Toll Free: 800-663-6556. Tel: (604) 594-0422 Fax: (604) 594-9915
Email: productinfo@garaventalift.com Web www.garaventalift.com
- B. Requests for substitutions will be considered in accordance with provisions of Section 01 60 00.

2.2 SHAFTWAY VERTICAL WHEELCHAIR LIFT

- A. Capacity: 750 lbs (340 kg) rated capacity.
- B. Mast Height:
 - 1. Model GVL SW -120; 123 inches (3124 mm) maximum lifting height.
- C. Nominal Clear Platform Dimensions:
 - 1. Standard: 39 inches (992 mm) by 54 inches (1370 mm).
- D. Platform Configuration:
 - 1. On/Off Same Side Entry/Exit: One front opening only.
- E. Landing Openings:
 - 1. Lower Landing: Door.
 - 2. Upper Landing: Door.
- F. Door Construction:
 - 1. Fire Rated Doors: 1-1/2 hour B label rating. Pre-hung, constructed of 16 gauge (1.5 mm) steel, with a vision panel, delayed action door closer, pull handle and integrated interlock. Doors mount flush to the inside wall of the shaftway.
 - 2. Door Width:
 - a. Lower Landing:
 - 1) 35-5/8 inches (905 mm).
 - b. Upper landing:
 - 1) 35-5/8 inches (905 mm).
- G. Lift Components:
 - 1. Machine Tower: Extruded aluminum.
 - 2. Base Frame: Structural steel tubing.
 - 3. Platform Side Wall Panels: 16 gauge (1.5 mm) galvanized steel sheet.
Aluminum extrusion tube frame.

- H. Base Mounting and Access to Lift at Lower Landing:
 - 1. Pit Mount: Lift to be mounted in pit with dimensions to meet manufacturer's requirements for the platform size specified. Pit construction shall be in accordance to Section 03 30 00.

- I. Drive Mast Side Wall Panels: Provide 16 gauge (1.5 mm) galvanized panels and mounting hardware to cover the void between both sides of the mast and the side of the shaftway. Panels to cover the front and top of the void area to the height of the top surface of the drive mast.

- J. Leadscrew Drive:
 - 1. Drive Type: Self-lubricating acme screw drive.
 - 2. Emergency Operation: Manual handwheel device to raise or lower platform.
 - 3. Battery Powered Emergency Lowering: Battery powered platform lowering device that automatically activates in the event of power failure. Allows passenger to drive platform downward to lower landing. Does not operate lift in up direction.
 - 4. Safety Devices:
 - a. Integral safety nut assembly with safety switch.
 - 5. Travel Speed: 10 fpm (3.0 m/minute).
 - 6. Motor: 2.0 hp (560 W).
 - 7. Power Supply:
 - a. 120 VAC single phase; 60 Hz on a dedicated 20-amp circuit.

- K. Platform Controls: 24 VDC control circuit with the following features.
 - 1. Direction Control: Illuminated tactile and continuous pressure buttons with dual platform courtesy lights and safety light.
 - 2. Illuminated and audible emergency stop switch shuts off power to lift and activates audio alarm equipped with battery backup.
 - 3. Keyless operation.
 - 4. Arrival Gong and Digital Floor Display.

- L. Call Station Controls: 24 VDC control circuit with the following features.
 - 1. Direction Control: Illuminated and tactile continuous pressure buttons with illuminated "in-use" indicator.
 - 2. Safety indicator lamp.
 - 3. Keyless operation.
 - 4. Call Station Mounting:
 - a. Lower:
 - 1) Frame mounted.
 - b. Upper:
 - 1) Frame mounted.

- M. Safety Devices and Features:
 - 1. Grounded electrical system with upper, lower, and final limit switches.
 - 2. At all landings a solenoid activated interlock shall electrically monitor that the door is in the closed position and the lock is engaged before lift can move from landing.
 - 3. Electrical disconnect shall shut off power to the lift.
- N. Finishes
 - 1. Extruded aluminum electrostatically applied baked powder finish semi matte Silver Moon.
 - 2. Ferrous Components: Electrostatically applied baked powder finish, semi matte.
 - a. Color: Silver Moon.

PART 3 EXECUTION

3.1 EXAMINATION

- A. Do not begin installation until substrates have been properly prepared.
- B. Verify shaft and machine space are of correct size and within tolerances.
- C. Verify required landings and openings are of correct size and within tolerances.
- D. Verify electrical rough-in is at correct location.
- E. If substrate preparation is the responsibility of another installer, notify Architect of unsatisfactory preparation before proceeding.

3.2 PREPARATION

- A. Clean surfaces thoroughly prior to installation.
- B. Prepare surfaces using the methods recommended by the manufacturer for achieving the best result for the substrate under the project conditions.

3.3 INSTALLATION

- A. Install platform lifts in accordance with applicable regulatory requirements including ASME A17.1, ASME A18.1 and the manufacturer's instructions.
- B. Install system components and connect to building utilities.
- C. Accommodate equipment in space indicated.
- D. Startup equipment in accordance with manufacturer's instructions.
- E. Adjust for smooth operation.

3.4 FIELD QUALITY CONTROL

- A. Perform tests in compliance with ASME A17.1 or A18.1 and as required by authorities having jurisdiction.
- B. Schedule tests with agencies and Architect, Owner, and Contractor present.

3.5 PROTECTION

- A. Protect installed products until completion of project.
- B. Touch-up, repair or replace damaged products before Substantial Completion.

END OF SECTION

SECTION 21 00 00
FIRE PROTECTION

PART I -- GENERAL

1.1 RELATED DOCUMENTS

- A. Drawings and General Provisions of Contract, including General and Supplementary Conditions and Division-1 Specification Sections, apply to work of this section.
- B. Bidders shall utilize a complete set of Bidding Documents in preparing of Bid including Drawings and Specifications. The Engineer assumes no responsibility for errors or misinterpretations resulting from the use of incomplete sets of Bidding Documents.

1.2 SUMMARY

- A. This section addresses materials and methods common to more than one Subcontractor. Refer to the drawings to determine the extent of work required of each individual trade.

1.3 DESCRIPTION OF WORK

- A. The work described herein shall be interpreted as work to be done by the Fire Protection Subcontractor. Work to be performed by other trades will be specifically referenced to a particular Contractor or Subcontractor.
- B. The work under this section shall consist of furnishing all labor, materials, equipment, supervision, transportation, construction, facilities, devices and incidentals necessary to provide complete fire protection systems as hereinafter described and as indicated on the drawings, including, but not limited to the following:
 - 1. Perform new hydrant flow test regardless of previous test data.
 - 2. Complete wet pipe sprinkler system.
 - 3. Complete pre-action sprinkler system within garage.
 - 4. Preparation of complete and detailed working plans and hydraulic calculations for each system in accordance with the latest editions of NFPA 13 and 14.
 - a. Submit Working Plans and hydraulic calculations signed and sealed by a Professional Engineer licensed to practice fire protection state in which project is located, to authorities that have jurisdiction, including:
 - 1. Architect
 - 2. Insurance Underwriter
 - 3. Fire Department
 - b. Working plans and computerized hydraulic calculations shall be prepared by a minimum Level 3 N.I.C.E.T. certified sprinkler layout designer. Drawings shall be signed and the N.I.C.E.T. certificate number indicated on plan.
 - c. Working plans shall be at least 1/8 in. = 1' 0" scale on sheets of uniform size. Working plans shall show all data required by NFPA 13 and 14. Submit working plans and hydraulic calculations in one complete package.
 - d. Working plans will be subject to Architect's final approval. Submit to Architect after review by other authorities. If necessary to submit plans to Architect before review by other authorities, identify authorities that have not reviewed plans and resubmit for final approval when review by all parties is complete.
 - e. Pipe sizing shall be based on hydraulic calculations of sprinkler and/or combination systems.
 - 5. Submit drawings to insurer and local authorities and obtain necessary approvals, permits and certificates.

6. Sprinkler heads, piping, fittings, hangers and valves.
7. Alarm check valve assemblies, trim, and water motor gong, excess pressure pump kits.
8. Fire department connection.
9. Flow, tamper and pressure switches.
10. Inspector's test stations, drain valves and piping.
11. Double check assembly.
12. Pressure gauges with shut off valves and drainage provisions on standpipes.
13. Sleeves, escutcheons, hangers and supports.
14. Fire safing of penetrations through rated floor and wall assemblies.
15. Signage.
16. Testing.
17. Completion and submission of NFPA 13 Contractor's material and test certificate for underground and above ground piping.
18. Core drilling
19. Coordination of drawings.
20. Dimensioned coring plan.

1.4 CODES, ORDINANCES AND PERMITS

- A. All material and work provided shall be in accordance with the following codes and standards:
 1. NFPA Pamphlets latest editions:
 - a. 13 - Installation of sprinkler systems & all referenced documents noted in Chapter 10.
 - b. 14 - Installation of standpipe and hose systems.
 - c. 25 - Inspection, testing and maintenance of water based fire protection systems.
 2. State Fire Safety Code
 3. State Department of Public Safety
 4. Standards of the Underwriter's Laboratories (UL)
 5. State and Local Building Codes
 6. Local Fire Department requirements
 7. Local Water Department requirements
 8. Owner's insurance company
 9. Insurance Service Organization (ISO)
 10. Factory Mutual (FM)
- B. Where the contract documents indicate more stringent requirements than the above codes and ordinances, the contract documents shall take precedence.
- C. File all documents, pay all fees and secure all inspections and approvals necessary for the work of this section.

- D. Include in the work, without extra cost to the Owner, any labor, materials, services, apparatus, drawings, in addition to contract drawings and documents in order to comply with all applicable local ordinances and regulations, whether or not shown on drawings and/or specified.
- E. It shall be the responsibility of this Contractor to prepare drawings showing complete and fully coordinated sprinkler head and piping layouts in accordance with the requirements of NFPA and those authorities having jurisdiction over this project. It shall also be the responsibility of the Sprinkler Subcontractor to obtain all approvals from local authorities and the Owner's Insurance Underwriter prior to submission to the Architect. Revise head location as required for areas that have ornate ceiling work or as requested by the Architect. Provide side wall heads in area's as instructed.

1.5 CONTRACT DRAWINGS

- A. The Contract Drawings are generally diagrammatic and convey the Scope of Work and General Arrangement of apparatus and equipment. The locations of all items shown on the drawings or called for in the specifications that are not definitely fixed by dimensions are approximate only. The exact locations necessary to secure the best conditions and results, must be determined at the project and shall have the approval of the Architect and Engineers before being installed. The Subcontractor shall follow drawings in laying out work and shall check drawings of the other trades to verify spaces in which work will be installed. Maintain maximum headroom and space conditions at all points. If directed by the General Contractor, Engineer and/or Architect, the Subcontractor shall, without extra charge, make reasonable modifications in the layout as needed to prevent conflict with work of other trades or before proper execution of the work.
- B. Specifications: The specifications are intended only to complement the drawings; however, work detailed and/or noted only on the drawings or work described only in the specifications shall all be considered as part of the scope of work.

1.6 SHOP DRAWINGS

- A. Within thirty (30) days after the date of notice to proceed, and before purchasing any materials or equipment, submit for approval a complete list, in six (6) copies, of all materials to be incorporated in the work.
- B. After the list has been processed, submit six (6) complete sets of shop drawings of all equipment. These shop drawing submittals shall be submitted within thirty (30) days after the processing date of the original submittal.
- C. All submittals shall be complete and shall be in three-ring loose-leaf binders. No consideration will be given to partial submittals, except with prior approval.
- D. The approval of the equipment does not relieve the Subcontractor of responsibility of shop drawing errors related to details, sizes, quantities, wiring diagram arrangements and dimensions which deviate from the Specifications, and/or job conditions as they exist.
- E. Refer to General Requirements for the substitutions of equipment and submittal of shop drawings. If apparatus or materials are substituted for those specified, and such substitution necessitates changes in, or additional connections, piping, supports, or construction, same shall be provided. The Sprinkler Subcontractor to assume cost and entire responsibility thereof.

1.7 RECORD DRAWINGS

- A. All costs related to the following requirements shall be paid for by this Subcontractor.
- B. Purchase and maintain at the job site a complete and separate black line set of prints of the Contract Drawings on which accurately indicate daily progress by coloring materials and apparatus as installed. Schedules shall be modified to reflect data consistent with that of the installed equipment. Clearly show all changes to the work as a result of change orders, instructions issued by the Architect or conditions encountered in the field.

Accurately indicate the location, size, type and elevation of new utilities and their relationship to existing utilities.

- C. The marked up and colored in prints will be used as a guide for determining the progress of the work installed. They shall be inspected weekly and shall be corrected immediately if found inaccurate or incomplete. Requisitions for payment will not be approved until the Drawings are accurate and up-to-date.
- D. At the completion of the work, submit one (1) set of marked up prints for review and comment. After review and comment, these marked up prints shall be used in the preparation of the Record Drawings. The Record Drawings shall consist of these prints (corrected) previously indicated, as well as two (2) CAD disks of the Final Coordination Drawings, corrected on the basis of the Architect/Engineer's final comments.
- E. Obtain and pay for one (1) set of reproducible mylars and CAD disks (AutoCAD Release 2000 minimum or compatible system) applicable to this Section. Make all modifications to these reproducibles as shown on the marked up prints. Remove all superseded data to show the completed installation.
- F. The Record Drawings may be made from the originals of the Contract Drawings. Arrange with the Architect to have these reproducibles made from the originals.
- G. Deliver the completed reproducible Record Drawings and CAD disks properly titled and dated to the Architect. These Record Drawings shall become the property of the Owner.

1.8 WORKING PLANS

- A. Submit Working Plans and hydraulic calculations signed and sealed by a Professional Engineer licensed to practice fire protection state in which project is located, to authorities that have jurisdiction, including:
 - 1. Architect
 - 2. Insurance Underwriter
 - 3. Fire Department
- B. Working plans and computerized hydraulic calculations shall be prepared by a minimum Level 3 N.I.C.E.T. certified sprinkler layout designer. Drawings shall be signed and the N.I.C.E.T. certificate number indicated on plan.
- C. Working plans shall be at least 1/8 in. = 1' 0" scale on sheets of uniform size. Working plans shall show all data required by NFPA 13 and 14. Submit working plans and hydraulic calculations in one complete package.
- D. Working plans will be subject to Architect's final approval. Submit to Architect after review by other authorities. If necessary to submit plans to Architect before review by other authorities, identify authorities that have not reviewed plans and resubmit for final approval when review by all parties is complete.
- E. Pipe sizing shall be based on hydraulic calculations of sprinkler and/or combination systems.

1.9 OPERATING INSTRUCTIONS AND MAINTENANCE MANUALS

- A. Operating Instructions: Provide operating instructions to the Owner's designated representative with respect to the operation functions and maintenance procedures for all equipment and systems installed. The cost of such instructions, up to a full three (3) days of the Contractor's time, shall be included in the contract price. The cost of providing a manufacturer's representative at the site for instructional purposes shall be included in the Contract Price.
- B. Maintenance Manuals: At the completion of the project, turn over to the General Contractor four (4) complete manuals in 3-ring binders, indexed, containing the following:

1. Complete shop drawings of all material and equipment in Part 2 of this section.
2. Operation description of all systems.
3. Names, addresses and telephone numbers of all suppliers of system components.
4. Preventative maintenance instruction for all systems.
5. Spare parts list of all system components.
6. Copies of all valve charts.

1.10 GUARANTEE

- A. The Contractor shall obtain in the General Contractor's and Owner's name, the standard written manufacturer's guarantee of all materials furnished under this Section where such guarantees are offered in the manufacturer's published product data. All these guarantees shall be in addition to, and not in lieu of, other liabilities which this Contractor may have by law or other provisions of the Contract Documents. The guarantee shall be for a period of one (1) year minimum from the date of acceptance or final payment.

1.11 STORAGE OF MATERIALS

- A. Store materials prior to their installation where designated by the General Contractor & Architect. This Contractor shall be responsible for all materials stored and protect all installed equipment from injury or defacement.

1.12 INSPECTION AND TESTS

- A. If inspection of materials installed shows defects, such defective work, materials, and/or equipment shall be replaced at no cost to the General Contractor or Owner, and the inspection and tests repeated.
- B. Make all reasonable tests as required, and prove the integrity of all work and leave the entire installation in correct adjustment and ready to operate.

1.13 COOPERATION WITH OTHER TRADES

- A. Give full cooperation to other trades and furnish in writing to the Architect any information necessary to permit the work of all trades to be installed satisfactorily and with the least possible interference or delay.
- B. Coordination drawings shall be initiated under Section 15500 of the Specifications. It is their responsibility for preparation of project coordination drawings showing the installation of all equipment, piping, ducts and accessories to be provided under Section 15500 of the Specifications. These drawings shall be prepared at not less than $\frac{3}{8}$ in. = 1 ft. scale, and shall show building room layouts, structural elements, ductwork and lighting layouts of function. A reproducible copy of each drawing prepared shall then be submitted to each Contractor working under Sections 15300, 15400 and 16000, who shall be responsible to coordinate his equipment and systems and shall show these on the drawings submitted. After this Contractor has fulfilled his obligation, he shall return the drawings to the HVAC Contractor. After each drawing has been coordinated between trades, each trade shall sign each drawing, indicating acceptance of the installation. The HVAC Contractor shall then print the coordination original and these prints submitted through the General Contractor to the architect for review and comment, similar to shop drawings. Comments made on these drawings shall result in a correction and re-submittal of the drawings.
- C. Furnish to other trades, as required, all necessary templates, patterns, setting plans, and shop details for the proper installation of work and for the purpose of coordinating adjacent work.
- D. The cost of preparing and reproducing these Drawings will be included as part of this Contract.

- E. Coordination Drawings shall not be construed as replacing any Shop Drawings.

1.14 UTILITY COMPANY COORDINATION

- A. This section includes, but is not limited to coordination with the following utilities, agencies and authorities having jurisdiction:
 - 1. Water Department: This Contractor shall coordinate with the local water department and provide all material & labor required to comply with the utility. Notify Engineer of discrepancies between the plans and the local utility company's standards. No extra compensation will be given for corrections required to this Contractor for failure to coordinate with the utility company, but corrections shall be made.
 - 2. Fire Department: Review plans and specifications with the local fire department. Obtain and pay for all permits.
 - 3. Building Inspector: Review plans and specifications with the local building inspector, if not done so by the General Contractor.
 - 4. OSHA Representative: Review plans and specifications with the local OSHA representative, if not done so by the General Contractor.
 - 5. Dig Safe: This contractor shall notify and coordinate with Dig Safe prior to any excavation; digging; trenching; grading; tunneling; augering; boring; drilling; pile driving; plowing-in or pulling-in pipe or other sub-structure; backfilling; demolition; and blasting related to this Contractor.
- B. The Fire Protection Contractor shall pay for all permits, inspections, labor, material and fees associated with the various Utility Companies coordination requirements mentioned in this section and for this Contractor's work under this project.
- C. HVAC, Plumbing, Fire Protection, and Electrical Drawings are diagrammatic. They indicate general arrangements of mechanical and electrical systems and other work. They do not show all offsets required for coordination nor do they show the exact routings and locations needed to coordinate with structural and other trades and to meet Architectural requirements.
- D. In all spaces, prior to installation of visible material and equipment, including access panels, review Architectural Drawings for exact locations and where not definitely indicated, request information from Architect. Where the plumbing work shall interfere with the work of other trades, assist in working out the space conditions to make satisfactory adjustments before installation. Without extra cost to the Owners, make reasonable modifications to the work as required by normal structural interferences. Pay the General Contractor for additional openings, or relocating and/or enlarging existing openings through concrete floors, walls, beams and roof required for any work which was not properly coordinated. Maintain maximum headroom at all locations. All piping, duct, conduit, and associated components to be as tight to underside of structure as possible.
- E. If any fire protection work has been installed before coordination with other trades so as to cause interference with the work of such trades, all necessary adjustments and corrections shall be made by the trades involved without extra cost to the Owners.
- F. Where conflicts or potential conflicts exist and engineering guidance is desired, submit sketch of proposed resolution to Architect and Engineer for review and approval.

1.15 BIDDER'S REPRESENTATION

- A. By the act of submitting a bid for the proposed contract, the Bidder represents that:

1. The Bidder and all subcontractors have carefully and thoroughly reviewed the drawings, specifications and other construction contract documents and have found them complete and free from ambiguities and sufficient for the purpose intended; further that.
2. The Bidder intends to use are licensed, skilled and experienced in the type of construction represented by the construction contract documents bid upon; further that.
3. Neither the Bidder nor any of the Bidder's employees, agents, intended suppliers or subcontractors have relied upon any verbal representations, allegedly authorized or unauthorized from the Owner, or the Owner's employees or agents including architects, engineers or consultants, in assembling the bid figure; and further that
4. The bid figure is based solely upon the construction contract documents and properly issued written addenda and not upon any other written representation.

1.16 CONFLICT BETWEEN PLANS AND SPECIFICATIONS

- A. In case of conflict between the contract drawings and specifications, the Engineer shall determine which takes precedence.

PART 2 - PRODUCTS

2.1 PIPING AND FITTINGS

- A. Above ground wet pipe sprinkler systems 2 in. or smaller: Pipe material shall be threaded steel pipe; Schedule 40; ASTM A53. Fittings shall be cast iron; Class 125 or 250, ANSI B16.4 with threaded joints.
- B. Above ground wet pipe sprinkler 2-1/2 in. or larger: Pipe material shall be steel pipe; Schedule 10; rolled groove without metal removal, ASTM A-135. Fittings for grooved end steel pipe shall be ductile iron, ASTM A-536, or steel, ASTM A-53, short radius or standard fittings with grooved or shouldered ends. Couplings shall be ductile iron conforming to ASTM A-536, with rigid joints, Victaulic style 75, 004, or 177 flexible joints with gasket, nuts and bolts.
- C. Pipe fittings and couplings used in the sprinkler systems shall be of the materials indicated above and shall be designed to withstand a working pressure of not less than 175 PSI.
- D. Pipe and fittings exposed to weather and piping used in dry pipe systems shall be galvanized.
- E. Dry Sprinkler System
 1. Pressure Rating: 175 psig minimum.
 2. Galvanized and Uncoated, Grooved-End Fittings for Steel Piping: ASTM A234 forged steel, ASTM A53 fabricated steel, or ASTM A 536, ductile-iron casting; with dimensions matching steel pipe.
 3. Grooved-End-Pipe Couplings for Steel Piping: AWWA C606 and UL 213, rigid pattern, unless otherwise indicated, for steel-pipe dimensions. Include ferrous housing sections, EPDM-synthetic rubber gasket, and bolts and nuts.
 4. Rigid Type: Housings shall be cast with offsetting, angle-pattern bolt pads to provide system rigidity and support and hanging in accordance with NFPA 13. Tongue and recess rigid type couplings shall only be permitted if the contractor uses a torque wrench for installation. Required torque shall be in accordance with the manufacturer's latest recommendation.

- 1) 1-1/4" through 8": "Installation Ready" stab-on design, for direct 'stab' installation onto grooved end pipe without prior field disassembly and no loose parts. Victaulic FireLock EZ Style 009H (1-1/4" – 4") and Victaulic Style 107H QuickVic (2" – 8").
- 2) 2" and Larger: Standard rigid coupling design. Victaulic FireLock Style 005 or Style 07 Zero-Flex.

2.2 HANGERS

- A. Hangers and hanging methods shall be NFPA 13 Standards or more stringent requirements, as specified herein. All hangers, clamps, rods, shields, etc., shall be UL listed and FM approved.
- B. Mains 4 in. and larger shall be supported using adjustable standard weight clevis hangers. Piping 3 in. and smaller shall be supported using standard adjustable flat iron hangers.
- C. Sprinkler piping shall be substantially supported from the building structure, and must support the load of the water filled pipe plus a minimum of 250 lb. applied to the point of hanging.
- D. Where the building structure is accessible only by penetrating one or more hung ceiling structures, holes of sufficient size to secure the hanger shall be cut, patched and painted by this Contractor. The use of an escutcheon or large diameter coverplate will not be allowed to conceal the cut openings, unless openings are uniform in size and of a small diameter which can be concealed by a rod button (finish selected by Architect). Cutting and patching of rated ceilings shall be performed in an acceptable manner to maintain the rating to the approval of the Architect and the Building Inspector.
- E. The use of toggle type hangers of any kind or wall and ceiling plates will not be allowed.
- F. Provide additional supports on piping as necessary to prevent movement of piping as required by the Architect and Engineer. Of particular concern are vertical runs of piping, and the top and bottom of standpipe risers. Supports may consist of wall plates, properly secured to the building structure, threaded rods, and split ring pipe clamps.
- G. Seismic Restraints: It is the intent of this seismic specification to keep all building system components in place during a seismic event.
 1. All systems must be installed in strict accordance with seismic codes, component manufacturer's and building construction standards. Whenever a conflict occurs between the manufacturer's or construction standards, the most stringent shall apply.
 2. This contractor shall engage a professional structural engineer registered in the jurisdiction of this project to review the entire installation to determine all seismic restraint requirements and methods. Contractor shall submit a report outlining the structural engineer's review as well as seismic restraint shop drawings and supporting calculations prepared by the professional structural engineer for review by the Architect.
 3. Seismic restraints shall be designed in accordance with seismic force levels as detailed in the applicable building code.

2.3 ALARM

- A. All alarm devices shall be U.L. listed and FM approved. Alarm facilities shall include a water motor gong (complete with an electric bell as required by local authority) located outside the building with hood and identification plate. The supply pipe from the water gong shall be I.P.S. brass or copper. Water motor alarms shall be Reliable Model C or equal as manufactured by Viking or Central.
- B. Supervisory switches shall be furnished and installed by the Sprinkler Subcontractor and wired by the Electrical Contractor. Potter-Electric 6220, Grinnell or Reliable.
- C. Flow switches shall be furnished and installed by the Fire Protection Contractor and wired by the Electrical Contractor. Potter-Roemer Fig. 6200 Series, red, tamper-proof switch

housings with flow paddle, adjustable pneumatic retard setting 0 - 70 seconds, voltage compatible with the fire alarm system. This Contractor shall set the retard as directed by the local fire department, or 45 seconds if there is no preference.

- D. Pressure switches shall be provided by this Subcontractor. Provide pressure switches to announce main water flow on wet alarm check valves.
 - 1. Pressure switches shall be UL listed and FM approved, minimum of 175 psi rated, of electrical characteristics to be compatible with the fire alarm system, with tamper proof cover screws, a weatherproof, oil resistant housing, as manufactured by Potter Electric Signal.
 - 2. Pressure switches to actuate alarms on a pressure rise between 4 and 8 psi (water flow detection) shall be Potter Electric signal Model PS10 Series.
 - 3. Pressure switches designed for high or low pressure supervisory applications, to detect a 10 psi increase or decrease in normal system pressure shall be Potter Electric signal PS40 Series. Provide a Model BVL bleeder valve to allow testing.

2.4 DRAINS AND TEST CONNECTIONS

- A. Furnish and install system drains so that all portions of the fire protection system can be drained. Drains shall be provided at the base or risers, low points or the ends of runs to ensure complete drainage. All drains that exit the building, will do so at ground level, in a manner approved by the Architect and Engineer.
- B. All system drains shall be concealed or exposed in mechanical spaces. Location of system drains will be specifically shown on the shop drawings.

2.5 VALVES

- A. All valves shall be free from defects and shall be stamped or marked with the manufacturer's name, FM approved and UL listed, of US manufacturer, and be rated for 175 psi working pressure.
- B. Ball valves 2 in. and smaller shall be rated to 350 psi and shall be bronze with chrome-plated brass ball and stainless steel stem, standard port, weatherproof actuator with pre-wired supervisory switches, grooved or threaded ends, Victaulic Series 728 or equal.
- C. Gate valves shall be of the 175 psi Standard Class. Valves 2 inches and smaller, shall be all bronze, with rising stem and screwed ends. Over 2 in. sizes shall be bronze mounted, iron body, outside screw and yoke type, flanged. The interior main service valves must be OS&Y gate type valves.
- D. Grooved end gate valves shall be of the 250 psi Standard Class, 2 in. and larger, and shall be ductile iron, bronze mounted, outside screw and yoke type, Victaulic Series 771, or non-rising stem type, Victaulic Series 772 with upright or wall post indicator (Series 773 or 774).
- E. Butterfly valves 2-1/2 in. and smaller shall be slow closing with visual position indicator, built-in supervisory tamper switch, ASTM 584 bronze body and housing, brass or cast iron handle, Type 304 stainless steel disc, EPDM elastomer seal, cast aluminum switch housing, grooved or threaded ends, Milwaukee Butterball BB SC Series or equal as manufactured by Central. The supervisory switch shall be SPDT rated for 10 amps, 115 VAC, .5 amps, 28 VDC. The entire assembly shall be UL listed, FM approved and rated for 175 psi working pressure. Butterfly valves shall not be used as the main fire service valves.
- F. Butterfly valves 3 in. and larger shall be slow closing with visual position indicator, built-in supervisory tamper switch, ASTM-66, ductile iron body and disc, EPDM seal, grooved or lug ends, Victaulic 765 (365 psi), or Victaulic 705 (300 psi), or equal. The supervisory switch shall be SPDT rated for 10 amps, 115 VAC, .5 amps, 28 VDC. The entire assembly shall be UL listed, FM approved and rated for minimum 175 psi of working pressure.
- G. Check valves shall be installed horizontally, and be iron body, bronze mounted, swing type, flanged ends, automatic ball drip, with manufacturer's name, pressure rating, and year of

manufacturer cast on body. (Victaulic S\717H (365 psi) or S/717 (300 psi) check valve with grooved ends is allowed subject to the approval of the local authority.)

- H. Fire department valves shall be Potter-Roemer Model 4065-D, 2-1/2 in. cast brass hose valve with 2810-RL, 2-1/2 in. female x 1-1/2 in. male reducer fitting with 4615-RL cap and chain and 4723 chrome plated escutcheon. Hose threads to be compatible with the local fire department standards. The finish of the valve reducer and cap shall be rough chrome plated. Where valves are submitted to 100 psi or higher, provide adjustable pressure restricting angle valves, Potter-Roemer Figure 4085. This valve shall have an adjustable flow restriction feature which may be overridden by removing a clip normally secured by a sealed band. This Contractor shall set the flow restriction device on each valve on each floor at an outlet pressure as directed by the local fire department.

2.6 SPRINKLER HEADS

- A. All sprinkler heads shall be UL listed and FM approved, and meet the specified criteria.
- B. Sidewall sprinkler heads where called for shall be horizontal sidewall low profile, glass bulb, chrome plated finish.
- C. In areas utilizing acoustical tile ceilings, heads shall be centered in tiles in both directions. Heads shall be located as close as practical to the center line of all corridors. Provide additional sprinkler heads, an allowance of 2% of the total sprinkler heads, to accommodate this condition. Unused funds of this allowance will be returned to the owner.
- D. Sprinklers in high heat areas, such as mechanical rooms, or below skylights shall have temperature rating of 212 degree F.
- E. Provide sprinkler head guards for all heads subject to accidental damage or vandalism.
- F. The pipe fitting supplying all new upright sprinkler heads shall be a minimum of 1 in. to allow the installation of pendant type sprinkler heads in the future.

2.7 SPARE HEADS

- A. The Contractor shall furnish spare heads equal to one percent of the total number installed under the Contract. The heads shall be packed in a suitable container, and shall be representative of, and in proportion to, the number of each type and temperature rating heads installed. No less than three of each type of head installed shall be provided as spares. In addition, two sprinkler head wrenches shall be provided.

2.8 FIRE DEPARTMENT CONNECTIONS

- A. Furnish and install a surface type fire department connection, cast brass inlet body, with drop clappers, pin lug swivels, plugs, chains, cast brass round wall plate with sillcock, equal to a Potter-Roemer Model 5750 Series, Elkhart or Guardian. Plate shall be lettered "AUTO SPKR STANDPIPE". Unit shall conform to the requirements of the local fire department. The finish shall be polished chrome plated.
- B. On the line to the fire department connection, provide an approved straightway check valve installed in horizontal position within the building. Piping shall be arranged to drain between check valve and siamese connection by approved ball drip connection piped to nearest drain or through wall.

2.9 DOUBLE CHECK VALVE ASSEMBLY

- A. Furnish and install where indicated on plan, an approved double check detector assembly having epoxy coated cast iron body with bronze seats and bronze body ball valve test cocks. The assembly shall be manufactured by Ames, Watts, or Hersey and be sized for the highest system demand.
- B. The double check detector assembly shall be provided with tight closing supervised valves on the inlet and outlet. Valves must be USC approved and must come with the assembly. The back flow prevention devices shall be approved by the following agencies: AWWA, UL, FM, USC, State DEP.
- C. The installation, meaning labor and materials shall be in accordance with the requirements

of the State DEP regulations and the Local Water Department regulations. (Note: Review requirements for metering of service with local authority and include such costs in bid. KCWA requires a full-size meter on all services).

- D. Submit plans to DEP and obtain permit for each reduced pressure or double check valve backflow preventer installation and submit copies of permit to Architect for record.
- E. Double Check Valve Assembly shall be Ames Fire & Waterworks 2000SS-OSY. The double check valve assembly shall consist of two independently operated spring loaded cam-check valves, required test cocks, and optional inlet and outlet resilient wedge shut-off valves. Each cam check shall be internally loaded and provide a positive drip tight closure against the reverse flow of liquid caused by backsiphonage or backpressure. The modular cam-check includes a stainless steel spring and cam-arm, rubber faced disc and a replaceable seat. The body shall be manufactured from 300 series stainless steel, 100% lead free through the waterway, with a single two-bolt access cover. UL/FM outside stem and yoke resilient seated gate valves shall be included.

2.10 ALARM CHECK VALVE ASSEMBLIES

- A. Wet alarm check valve shall be approved vertical type for wet systems, complete with Series 752 retard chamber, alarm switch, drain valve, pressure gauges, electric alarm bell and other required trimmings. Valve internal components shall be replaceable without removing valve from the installed position. Similar to Victaulic FireLock® NXT Series 751, Viking, or equal as approved; and UL/FM Global approved.
- B. Main drains from alarm check valves shall be piped to discharge on grade, where approved by architect.

2.11 SYSTEMS IDENTIFICATION

- A. All valves in the sprinkler system shall have permanent signs indicating their purpose.
- B. A legend shall be placed at the main shut off valve indicating the location of shut off valves and inspectors test valves.
- C. If fire suppression control valves are located in a separate room or concealed space, a sign shall be provided on the entrance door or near concealed space. The lettering for such sign shall be red and at least 4 in. in height, and shall read, "SPRINKLER CONTROL VALVE".
- D. Where necessary, provide metal or phenolic signage or lettering of the approximate size and color and message to identify items. Examples of typical signage would be "AUXILIARY DRAIN", "INSPECTOR'S TEST MAIN DRAIN", or "FIRE VALVE CABINET".
- E. All signage shall be attached with non-corrosive chain or screws per NFPA.
- F. Provide information signs on the alarm check valves of all hydraulically designed systems bearing the design data per NFPA 13.

2.12 FIRE SAFING

- A. Where piping passes through fire rated walls, floors and ceilings, provide a fire safing system so as to maintain the integrity of the rated assemblies to the satisfaction of the Architect and the Building Inspector. The fire safing system shall be as manufactured by 3M, Dow, Bio-Fire Shield, or Nelson. Provide manufacturer's details or custom details when there are no manufacturer's details for each condition with a UL listing referenced. Where there piping is insulated, pipe insulation shall run continuously through the rated opening. Details shall show the required depth and annular space width requirements and limitations and any packing requirements.
- B. Refer to architectural drawings for rated walls and partitions. When there are not architectural drawings, or they do not indicate rated walls and partitions, the following guide lines shall be used: All floors, corridor walls, party walls, mechanical room walls, duct and pipe chase walls, stairwells, trash room and chute walls shall be considered minimum two hour fire rated walls.

2.13 ESCUTCHEONS

- A. Install escutcheons around exposed pipe passing through finished floor, wall or ceiling. Escutcheons shall be one piece heavy cast brass, chromium plated, with set screw adjustable and shall be of sufficient outside diameter to cover sleeve opening and shall fit snugly around pipe.

PART 3 - EXECUTION

3.1 WORKMANSHIP

- A. The entire work provided in this specification shall be constructed and finished in every respect in a workmanlike and substantial manner. It is not intended that the drawings shall show every pipe, fitting, and appliance. Furnish all parts as may be necessary to complete the system in accordance with the best trade practices and to be the satisfaction of the Architect, Engineer and General Contractor.
- B. This Contractor shall keep other contractors fully informed as to the shape, size and position of all openings required for his apparatus and shall give full information to the General Contractor or other contractors sufficiently in advance of the work so that all openings may be built in advance. Furnish and install all sleeves, supports, etc., specified or required.
- C. In the case of failure on the part of this Subcontractor to give proper and timely information as noted above, he shall do his own cutting and patching, or have same done by the General Contractor at this Subcontractor's expense, but in any case, without extra expense to the Owner.
- D. This Contractor shall obtain detailed information from the manufacturer of apparatus as to the proper method of installing and connecting same. He shall also obtain all information from the General Contractor and the other contractors which may be necessary to facilitate his work and the completion of the whole project.

3.2 CORE DRILLING

- A. All holes through concrete or masonry for the passage of fire protection piping not provided by sleeves or openings at the time of casting, shall be cut by the Fire Protection Contractor using an approved core boring machine with diamond edge bit and vacuum sludge removal device. The size of holes shall provide for fire stopping around a pipe. The location of all core drilled holes shall be coordinated with the structural reinforcing and be reviewed by the Architect prior to commencing work.
- B. Prior to coring, the Sprinkler Subcontractor shall submit a minimum 1/8 in. scale plan, dimensioning the location of proposed cored opening locations and indicating the core diameter. Prior to developing the coring plan, the Sprinkler Subcontractor shall examine the site carefully in an attempt to determine whether there are structural, mechanical or electrical obstacles in the proposed coring locations. Once the plans are reviewed by the Architect and Owner's representative, the Sprinkler Subcontractor may proceed with caution.

3.3 TESTING PIPING SYSTEMS

- A. Test all work in the presence of the Architect/Engineer and/or Owner, Owner's representative and Fire Inspector as called for in local codes in the following manner:
 - 1. Upon completion and prior to acceptance of the installation, the new fire Protection work shall be tested as required by the National Fire Protection association Pamphlet No. 13, 14 and Insurance Underwriter and arrangements made for approval. Piping shall be tested to a hydrostatic test pressure of 200 psi for a period of two hours.
 - 2. Provide 48 hours notice prior to commencing tests.
- B. Testing shall include piping from the fire department connection to the alarm check valve.
- C. Any leaks in joints or evidence of defective pipe or fittings disclosed by tests shall be

immediately corrected by replacing defective parts with new joints or materials. No makeshift repairs effected by caulking threaded pipe with lead wool, application of wicking or patented compounds being permitted. Perform smoke tests as required by local code or by the Architect/Engineer.

D. This subcontractor shall furnish all equipment, labor and materials, required for these tests.

3.4 PROTECTION PIPING

A. Each subcontractor shall be responsible for his work and equipment until finally inspected, tested and accepted. Carefully store materials and equipment which are not immediately installed after delivery on site. Close open ends or work with temporary covers or plug during construction to prevent entry of obstructing materials.

B. Each subcontractor shall protect work and materials of other trades from damage that might be caused by his work or workman and make good damage thus caused.

C. The premises shall be kept reasonably clean at all times, and rubbish shall be removed as directed by the General Contractor.

D. Upon completion of this work, this Contractor shall clean all equipment and replace damaged parts. Upon failure of this Contractor to fulfill his obligation, this work will be taken care of at his expense.

3.5 WORK COORDINATION AND JOB COORDINATION

A. Sprinkler system and equipment shall not be installed in congested and possible problem areas without first coordinating the installation of same with the other trades and the General Contractor.

B. Particular attention shall be directed to the coordination of system with all equipment of other trades installed in and above the ceiling areas. Conflicts in heights and clearance above hung ceilings shall be brought to the attention of the General Contractor for a decision before equipment is installed.

C. Furnish to the General Contractor and other trades all information relative to the position of the sprinkler/standpipe installation that will affect them so that they may plan their work and installation accordingly.

3.6 SUPPLEMENTARY STEEL, CHANNEL AND SUPPORTS

A. Furnish and install all supplementary steel, channels and supports required for the proper installation, mounting and support of all equipment.

B. Supplementary steel and channels shall be firmly connected to building construction in a manner approved by the Architect/Engineer.

C. The type and size of the supporting channels and supplementary steel shall be determined by the Sprinkler Subcontractor and shall be sufficient strength and size to allow only a minimum deflection in conformance with the manufacturer's requirements for loading.

D. All supplementary steel and channels shall be installed in a neat and workmanlike manner parallel to the walls, floor and ceiling construction. All turns to be made with 90 degree fittings, as required to suit the construction and installation conditions.

3.7 SLEEVES AND INSERTS

A. Sleeves shall be furnished, set and properly secured in place and at all points where piping passes through masonry or concrete. All sleeves shall be of sufficient diameter to provide 4 in. clearance around piping 4" and greater and 2 in. clearance around pipe less than 4" in diameter.

B. Sleeves through concrete slabs, and interior concrete and masonry walls or partitions shall be steel pipe. Fire stop annular openings between sleeves and pipes at floor slab passages and make watertight. Galvanized sleeves and copper piping shall not be placed in concrete.

- C. Install UL listed and FM approved inserts or other anchoring devices in concrete and masonry construction as required to support piping. Inserts shall be of the adjustable type as manufactured by Carpenter and Patterson, Grinnell, or Fee and Mason.

3.8 WATER SUPPLY

- A. Water supply data shall be recent and shall include static pressure and residual pressure flowing at greater than the demand GPM. Flow tests shall be dated less than one year from date of receipt of the contract. Flow tests dated later than one year shall not be valid, and a new test shall be performed by this Contractor to the requirements of NFPA. Tests shall be taken at hydrants in close proximity (within 500 ft.) of the building to be serviced.

3.9 INSTALLATION OF SPRINKLER AND STANDPIPE PIPING

- A. Pipe, fittings and hangers shall be installed in accordance with the recommendations of NFPA 13 and 14, in a neat and workmanlike manner.
- B. Where possible, all piping shall be concealed. Where it is not possible to conceal piping, it shall be located as inconspicuously as possible to minimize the visual impact and shall be approved by the Architect prior to installation.
- C. Care shall be taken to insure that all new piping shall be installed in practical alignment. Pitch piping to drain or draw-off points.
- D. Test valves and flushing connections shall be provided in the piping system as required for proper operation and by code.
- E. Provide a minimum 48 hours notice prior to shut-down of the sprinkler system.

END OF SECTION

SECTION 22 00 00

PLUMBING

PART I -- GENERAL

1.1 RELATED DOCUMENTS

- A. Drawings and General Provisions of Contract, including General and Supplementary Conditions and Division-1 Specification Sections, apply to work of this section.
- B. Bidders shall utilize a complete set of Bidding Documents in preparing of Bid including Drawings and Specifications. The Engineer assumes no responsibility for errors or misinterpretations resulting from the use of incomplete sets of Bidding Documents.
- C. Coordinate work with that of all other trades affecting or affected by work of this Section. Cooperate with such trades to assure the steady progress of all work under the Contract.

1.2 DEFINITIONS

- A. As used in the drawings and specifications for plumbing work, certain non-technical words shall be understood to have specific meanings as follows, regardless of indications to the contrary in the General Conditions of other documents governing the plumbing work.
- B. As used in this section, "provide" means "furnish and install", and "POS" means "Provided under Other Sections".
- C. "Approved Equal" means any equipment or material, which is approved by the engineer, and equal in quality, durability, appearance, strength, design and performance to the equipment or material originally specified.
- D. "Alternate" means an amount proposed by bidders and stated on the Bid Form for certain work defined in the Bidding Requirements that may be added to or deducted from the base bid amount if Owner decides to accept a corresponding change either in the amount of construction to be completed or in the products, materials, equipment, systems, or installation methods described in the Contract Documents.
- E. The cost or credit for each alternate is the net addition to or deduction from the Contract Sum to incorporate alternate into the Work. No other adjustments are made to the Contract Sum.
- F. "Concealed" means hidden in chases, furred spaces, walls, above ceilings or enclosed in construction.
- G. "Contractor and/or Subcontractor" specifically means, the Plumbing Subcontractor working under this Section of the Specification.
- H. "Exposed" means visible, in sight, or not installed "concealed" as defined above.
- I. "Furnish" or "Provide" means:
 - 1. Purchase and deliver to the project site complete with every necessary appurtenance and support, all as part of the plumbing work. Purchasing shall include payment of all sales taxes and other surcharges as may be required to assure that purchased item(s) are free of all liens, claims, or encumbrances.
 - 2. To supply, erect, install and connect in complete readiness for operation, the particular work referred to, unless otherwise specified.
- J. "Install" means: Unload at the delivery point at the site and perform every operation necessary to establish secure mounting and correct operation at the proper location in the project, all as part of the plumbing work.
- K. "May" means: A permissive term.
- L. "New" means: Manufactured within the past two (2) years and never before used.
- M. "Piping" means all piping including fittings, joints, hangers, supports and valves.

- N. "Provide" means: "Furnish" and "Install".
- O. "Shall" means: A mandatory term.
- P. "Underground or Below Slab" means piping that is buried exterior to or within the building.
- Q. Except where modified by a specific notation to the contrary, it shall be understood that the indication and/or description of any plumbing item in the drawings or specifications for plumbing work carries with it the instruction to furnish, install and connect the item as part of the plumbing work, regardless of whether or not this instruction is explicitly stated.
- R. It shall be understood that the specifications and drawings for plumbing work are complimentary and are to be taken together for a complete interpretation of the plumbing work except that indications on the drawings, which refer to an individual element of work, take precedence over the specifications where they conflict with same.

1.3 SUMMARY

- A. This section addresses materials and methods common to more than one Subcontractor. Refer to the drawings to determine the extent of work required of each individual trade.

1.4 DESCRIPTION OF WORK

- A. The work described herein shall be interpreted as work to be done by the Plumbing Subcontractor. Work to be performed by other trades will be specifically referenced to a particular Contractor or Subcontractor.
- B. The work under this section shall consist of furnishing all labor, materials, equipment, supervision, transportation, construction, facilities, devices and incidentals necessary to provide complete plumbing systems as hereinafter described and as indicated on the drawings, including, but not limited to the following:
 - 1. Domestic cold water system.
 - 2. Domestic hot water supply and recirculation systems.
 - 3. Non-potable cold water system.
 - 4. Non-potable hot water supply and recirculation systems.
 - 5. Sanitary, waste and vent system.
 - 6. Kitchen waste and vent system. This system shall discharge separately from the building and connect to an exterior grease interceptor as provided under Utility Structures. This Plumbing Sub-Contractor shall make special provisions for the witnessing and supervision of the installation of the exterior grease interceptor and associated piping.
 - 7. Indirect waste associated with food service equipment.
 - 8. Complete under slab water drainage system and / or foundation water drainage system per Geotechnical Report.
This system has not been represented in plan view on architectural or structural drawings.
This Plumbing Sub-Contractor shall assume that the entire system be provided with 6 inch PVC Schedule 40 perforated pipe.
 - 9. Complete beer and soda beverage conduit piping systems as indicated on the Food Service Equipment Drawings.
 - 10. Natural gas system.
This system shall extend and connect to the house side of the meter provided by the Utility Company.

1.5 RELATED WORK IN OTHER SECTIONS

- A. The following work is not included as work in this Section and is to be performed under other Sections:

1. Fire Protection
2. Heating, Ventilating and Air Conditioning
3. Electrical
4. Utilities Beyond 5'-0" from the Building
5. Excavation and Backfilling
6. Foundations and Trenching
7. Cast in Place Concrete
8. Temporary Light and Power
9. Temporary Water, Heat, Fire Protection, and Toilet Facilities
10. Concrete Bases for Equipment
11. Installation of Access Panels
12. Flashing and Caulking
13. All Cutting and Patching
14. Painting
15. Toilet Room Accessories
16. Design of underslab and foundation water drainage system.

1.6 CODES, ORDINANCES, AND PERMITS

- A. All materials and workmanship shall comply with the latest editions of all applicable Codes, Local and State Ordinances, Industry Standards, and Regulations.
- B. Where the contract documents indicate more stringent requirements than the following codes and ordinances, the contract documents shall take precedence.
- C. In the event of a conflict with Codes, the most stringent requirements shall apply.
- D. The Plumbing Subcontractor shall notify the Architect/Engineer of any discrepancies between the Contract Documents and applicable Codes, Standards, etc.
- E. File all documents, pay all fees and secure all permits, inspections and approvals necessary for the work of this section.
- F. Include in the work, without extra cost to the Owner, any labor, materials, services, apparatus, drawings, in addition to contract drawings and documents in order to comply with all applicable local ordinances and regulations, whether or not shown on drawings and/or specified.
- G. The following Codes, Standards and References shall be utilized as applicable:
 1. 2018 International Building Code
Rhode Island State Building Code Regulation SBC-1-2021
 2. 2018 International Plumbing Code
Rhode Island State Plumbing Code Regulation SBC-3-2019
 3. 2018 International Energy Conservation Code
Rhode Island State Energy Conservation Code SBC-8-2021
 4. 2018 Rhode Island Fire Safety Code
 5. Rules and Regulations of the Narragansett Bay Commission
 6. 2009 International Code Council A117.1 Accessible and Usable Buildings and Facilities
 7. Local Ordinances, Board of Health requirements and Regulations.

8. American Gas Association (AGA).
9. American National Standards Institute (ANSI).
10. American Society of Heating, Refrigerating and Air Conditioning Engineers (ASHRAE).
11. American Society of Mechanical Engineers (ASME).
12. American Society of Testing Materials (ASTM).
13. American Welding Society (AWS).
14. Cast Iron Soil Pipe Institute (CISPI)
15. Commercial Standards, U.S. Department of Commerce (CS).
16. Department of Environmental Protection (DEP).
17. Environmental Protection Agency (EPA).
18. Factory Mutual (FM).
19. Industrial Risk Insurers (IRI).
20. Insurance Services Organization (ISO).
21. Manufacturers Standardization Society of the Valve and Fittings Industry (MSS).
22. National Electric Code (NEC).
23. National Electrical Manufacturers Association (NEMA).
24. National Fire Protection Association (NFPA).
25. Occupational Safety and Health Administration (OSHA)
26. Owner's Insurance Company Requirements.
27. State Department of Public Safety.
28. Underwriters' Laboratories, Inc. (UL).

1.7 CONTRACT DRAWINGS AND SPECIFICATIONS

- A. The Contract Drawings are generally diagrammatic and convey the Scope of Work
- B. and General Arrangement of apparatus and equipment. The locations of all items shown on the drawings or called for in the specifications that are not definitely fixed by dimensions are approximate only. The exact locations necessary to secure the best conditions and results must be determined at the project and shall have the approval of the Architect and Engineer before being installed. The Subcontractor shall follow drawings in laying out work and shall check drawings of the other trades to verify spaces in which work will be installed. Maintain maximum headroom and space conditions at all points. If directed by the General Contractor, Engineer and/or Architect, the Subcontractor shall, without extra charge, make reasonable modifications in the layout as needed to prevent conflict with work of other trades or before proper execution of the work.
- C. Specifications: The specifications are intended only to complement the drawings; however, work detailed and/or noted only on the drawings or work described only in the specifications shall all be considered as part of the scope of work.

1.8 OBTAINING INFORMATION

- A. Obtain from the manufacturer the proper method of installation and connection of the equipment that is to be furnished and installed. Obtain all information that is necessary to facilitate the work and to complete the project.

1.9 COOPERATION AND COORDINATION WITH OTHER TRADES

- A. The Contract Drawings are diagrammatic only intending to indicate general routing and location of piping and equipment. The Drawings are not intended to show every offset and accessory required, nor every structural difficulty that may be encountered.
- B. Where requirements of the applicable codes, plans and/or specifications are in conflict, the most stringent requirement will be included in the Contract. Prior to ordering and/or installing any portion of the work which appears to be in conflict, the work shall be brought to the Architect/Engineer's attention for direction as to what is provided.
- C. Final location of plumbing fixtures and other pieces of equipment, whether or not furnished by the Plumbing Subcontractor, requiring plumbing services shall be coordinated with the Architectural Plans. Additional offsets, fittings, etc., shall be provided as needed to meet this requirement at no extra cost to the Owner.
- D. If discrepancies exist in the scope of work as to what trade provides items, they shall be reported to the Architect/Engineer prior to signing the Contract. If the discrepancies are not reported, the Plumbing Subcontractor shall furnish such items as needed for a complete and operable system.
- E. All work shall be installed in cooperation with other trades.
- F. Keep fully informed as to the shape, size and position of all openings required for all apparatus and give information in advance to build openings into the work. Furnish and set in place all sleeves, pockets, supports and incidentals.
- G. All distribution systems which require pitch or slope such as plumbing drains, steam and condensate piping shall have the right of way over those which do not. Confer with other trades as to the location of pipes, ducts, lights and apparatus and install work to avoid interferences.
- H. Prepare and submit for review, coordinated Plans and sections, clearly showing how the work is to be installed in relation to the work of other trades. Work that is installed before coordination with other trades, or that causes interference with the work of other trades shall be changed to correct condition.
- I. The Plumbing Contractor shall pay for all permits, inspections, labor, material and fees associated with the various Utility Companies coordination requirements mentioned in this section and for this Contractor's work under this project.
- J. HVAC, Plumbing, Fire Protection, and Electrical Drawings are diagrammatic. They indicate general arrangements of mechanical and electrical systems and other work. They do not show all offsets required for coordination nor do they show the exact routings and locations needed to coordinate with structural and other trades and to meet Architectural requirements.
- K. In all spaces, prior to installation of visible material and equipment, including access panels, review Architectural Drawings for exact locations and where not definitely indicated, request information from Architect. Where the plumbing work shall interfere with the work of other trades, assist in working out the space conditions to make satisfactory adjustments before installation. Without extra cost to the Owners, make reasonable modifications to the work as required by normal structural interferences. Pay the General Contractor for additional openings, or relocating and/or enlarging existing openings through concrete floors, walls, beams and roof required for any work which was not properly coordinated. Maintain maximum headroom at all locations. All piping, duct, conduit, and associated components to be as tight to underside of structure as possible.
- L. If any plumbing work has been installed before coordination with other trades so as to cause interference with the work of such trades, all necessary adjustments and corrections shall be made by the trades involved without extra cost to the Owners.
- M. Where conflicts or potential conflicts exist and engineering guidance is desired, submit sketch of proposed resolution to Architect and Engineer for review and approval.

1.10 UTILITY COMPANY COORDINATION

- A. This section includes, but is not limited to coordination with the following utilities, agencies and authorities having jurisdiction:
 - 1. Water Department: This Contractor shall coordinate with the local water department and provide all material & labor required to comply with the utility. Notify Engineer of discrepancies between the plans and the local utility company's standards. No extra compensation will be given for corrections required to this Contractor for failure to coordinate with the utility company, but corrections shall be made.
 - 2. Sewer Department: This Contractor shall coordinate with the local sewer department and provide all material & labor required to comply with the utility. Notify Engineer of discrepancies between the plans and the local utility company's standards. No extra compensation will be given for corrections required to this Contractor for failure to coordinate with the utility company, but corrections shall be made.
 - 3. Plumbing Inspector: Review plans and specifications with the local plumbing inspector. Obtain and pay for all permits.
 - 4. Building Inspector: Review plans and specifications with the local building inspector, if not done so by the General Contractor.
 - 5. OSHA Representative: Review plans and specifications with the local OSHA representative, if not done so by the General Contractor.
 - 6. Dig Safe: This contractor shall notify and coordinate with Dig Safe prior to any excavation; digging; trenching; grading; tunneling; augering; boring; drilling; pile driving; plowing-in or pulling-in pipe or other sub-structure; backfilling; demolition; and blasting related to this Contractor.

1.11 BIDDER'S REPRESENTATION

- A. By the act of submitting a bid for the proposed contract, the Bidder represents that:
 - 1. The Bidder and all subcontractors have carefully and thoroughly reviewed the drawings, specifications and other construction contract documents and have found them complete and free from ambiguities and sufficient for the purpose intended; further that.
 - 2. The Bidder intends to use are licensed, skilled and experienced in the type of construction represented by the construction contract documents bid upon; further that.
 - 3. Neither the Bidder nor any of the Bidder's employees, agents, intended suppliers or subcontractors have relied upon any verbal representations, allegedly authorized or unauthorized from the Owner, or the Owner's employees or agents including architects, engineers or consultants, in assembling the bid figure; and further that
 - 4. The bid figure is based solely upon the construction contract documents and properly issued written addenda and not upon any other written representation.

1.12 SHOP DRAWINGS

- A. Within thirty (30) days after the date of notice to proceed, and before purchasing any materials or equipment, submit for approval a complete itemized list, in six (6) copies, of all materials, equipment and of Subcontractors to be incorporated under this Section.
- B. After approval of the list, submit for review a minimum of eight (8) sets of detailed shop drawings. All shop drawings for equipment submitted for review shall include complete Specifications, including type of materials, operating pressures and temperatures, capacities, performance and power requirements to determine compliance with Contract Documents. All data submitted shall be complete for all equipment and shall apply only to this specific project.
- C. All shop drawing submittals shall be complete and include all Part 2 – Products of this specification and be clearly identified. No consideration will be given to partial submittals, except with prior approval.

- D. Facsimiles of any type will not be accepted.
- E. A written letter from the Plumbing Contractor stating all piping systems above and below ground specified herein have been tested, flushed and approved by the Local Plumbing Inspector.
- F. A written letter from the Plumbing Contractor stating all water piping systems above and below ground specified herein have been sterilized, flushed and approved by the Local Plumbing Inspector.
- G. A written letter from the Plumbing Contractor stating all gas piping systems specified herein have been tested, purged and approved by the local Plumbing and / or Gas Inspector.
- H. Provide test certificates, registration forms, diagrams, plans, details, permits, etc. for all backflow devices, as specified herein with a written cover letter from a certified backflow protection device tester stating that all testable backflow devices have been tested.
- I. A written letter, stamped and signed by a Registered Structural Engineer, confirming that the pipe hanger system meets the state seismic code requirements.
- J. A written cover letter, attached to the insulation materials submittals, from the Insulation Contractor stating an outline for all insulating materials furnished and installed for all piping systems specified herein.
- K. If foreign materials are used, Engineer shall be informed in writing together with any information about them he requires for approval.
- L. Engineering Design Service's reserves the right to request additional submittals on any item not specified herein under this section.
- M. The approval of the equipment does not relieve the Subcontractor of responsibility of shop drawing errors related to details, sizes, quantities, wiring diagram arrangements and dimensions which deviate from the Specifications, and/or job conditions as they exist.
- N. Refer to General Requirements for the substitutions of equipment and submittal of shop drawings. If apparatus or materials are substituted for those specified, and such substitution necessitates changes in, or additional connections, piping, supports, or construction, same shall be provided. Plumbing Subcontractor to assume cost and entire responsibility thereof.
- O. Regardless of any information included in the shop drawing submitted for review, the requirements of the Drawings and Specifications shall not be superseded in any way by the shop drawing review.
- P. Each submittal shall be reviewed, stamped and certified prior to submission to the Architect. Such certification shall be made by the Owner, or Corporate Officer of the Contractor, or by a person duly authorized by the Owner to sign binding agreements for the Contractor. The certification shall state that data and details contained on each shop drawing, layout drawing, catalog data and brochure has been reviewed by the Contractor and that it complies with the Contract Documents in all respects. Shop drawings, layout drawings, catalog data and brochures will not be reviewed and will be returned to the Contractor unchecked unless they are certified.
- Q. It is intended that the Contractor submit complete and accurate data at the first submission. If the shop drawing is returned marked "Does not Conform", or "Resubmit For Final Review", only one (1) additional submission will be permitted.
- R. Equipment shall be of proper size for its allotted space. Equipment shall be disassembled as required, without invalidating the manufacturer's warranty, so that it can be installed through regular window, door and/or louver openings.
- S. The shop drawings and manufacturer's data shall be submitted in a timely manner sufficiently in advance to give ample time for checking, correcting, resubmitting and rechecking if necessary. No claim for delay will be granted for failure to comply with this requirement.

- T. A minimum period of two (2) weeks, exclusive of transmittal time, will be required in the Engineer's office each time shop drawings, layout drawings and catalog data and brochures are submitted or resubmitted for review. This time period shall be considered by the Contractor when scheduling his work.

1.13 EXCAVATION AND BACKFILL

- A. Pipe bedding shall be in accordance with provisions of sections on excavation and backfill. Work under this section shall commence only after proper bedding material has been provided, graded and properly compacted. Excavation shall be kept open until system has been inspected, tested and approved.
- B. The Plumbing Contractor shall observe all excavation, backfilling and compaction of all underground piping associated with work under this section.

1.14 RECORD DRAWINGS

- A. All costs related to the following requirements shall be paid for by this Subcontractor.
- B. Purchase and maintain at the job site a complete and separate black line set of prints of the Contract Drawings on which accurately indicate daily progress by coloring materials and apparatus as installed. Schedules shall be modified to reflect data consistent with that of the installed equipment. Clearly show all changes to the work as a result of change orders, instructions issued by the Architect or conditions encountered in the field. Accurately indicate the location, size, type and elevation of new utilities and their relationship to existing utilities.
- C. The marked up and colored in prints will be used as a guide for determining the progress of the work installed. They shall be inspected weekly and shall be corrected immediately if found inaccurate or incomplete. Requisitions for payment will not be approved until the Drawings are accurate and up-to-date.
- D. At the completion of the work, submit one (1) set of marked up prints for review and comment. After review and comment, these marked up prints shall be used in the preparation of the Record Drawings. The Record Drawings shall consist of these prints (corrected) previously indicated, as well as two (2) CAD disks of the Final Coordination Drawings, corrected on the basis of the Architect/Engineer's final comments.
- E. Obtain and pay for one (1) set of reproducible mylars and CAD disks (AutoCAD Release 2000 minimum or compatible system) applicable to this Section. Make all modifications to these reproducibles as shown on the marked up prints. Remove all superseded data to show the completed installation.
- F. The Record Drawings may be made from the originals of the Contract Drawings. Arrange with the Architect to have these reproducibles made from the originals.
- G. Deliver the completed reproducible Record Drawings and CAD disks properly titled and dated to the Architect. These Record Drawings shall become the property of the Owner.

1.15 OPERATING INSTRUCTIONS AND MAINTENANCE MANUALS

- A. Operating Instructions: Provide operating instructions to the Owner's designated representative with respect to the operation functions and maintenance procedures for all equipment and systems installed. The cost of such instructions, up to one full day of the Contractor's time, shall be included in the contract price. The cost of providing a manufacturer's representative at the site for instructional purposes shall be included in the Contract Price. Included shall be a letter with two (2) copies containing the name of the person or persons to whom the instructions were given and the dates of the instruction period shall be submitted to the Architect at the completion of the project.
- B. Maintenance Manuals: At the completion of the project, turn over to the General Contractor four (4) complete manuals in 3-ring binders containing only that information which specifically applies to this project and all unrelated material shall be deleted, indexed, containing the following:

1. Complete shop drawings of all material and equipment in Part 2 of this section.
2. Operation descriptions of all systems.
3. Provide name, address and telephone number of the manufacturer's representative and service company for each piece of equipment so that the source of replacement parts and service for each item of equipment can be readily obtainable.
4. Preventative maintenance instructions for all systems.
5. Spare parts list of all system components.
6. Copies of all valve charts.
7. During the instruction period this manual shall be used and explained.

1.16 GUARANTEE

- A. This Contractor shall obtain in the General Contractor's and Owner's name, the standard written manufacturer's guarantee of all materials furnished under this Section where such guarantees are offered in the manufacturer's published product data. All these guarantees shall be in addition to, and not in lieu of, other liabilities which the Contractor may have by law or other provisions of the Contract Documents. The guarantee shall be for a period of one (1) year minimum from the date of acceptance or final payment.
- B. Any failure due to defective material, equipment or workmanship which may develop shall be corrected at no expense to the Owner, including all damage to areas, materials and other systems resulting from such failures.
- C. Upon receipt of notice from the Owner of failure of any part of the systems during the guarantee period, the affected parts shall be replaced. Any equipment requiring excessive service shall be considered defective and shall be replaced.

1.17 STORAGE OF MATERIALS

- A. Store materials prior to their installation where designated by the General Contractor. This Contractor shall be responsible for all materials stored and protect all installed equipment from injury or defacement.

1.18 PROTECTION OF WORK AND PROPERTY

- A. Be responsible for the care and protection of all work included under this Section until it has been tested and accepted.
- B. Protect all equipment and materials from damage from all causes including theft. All materials and equipment damaged or stolen shall be repaired or replaced with equal material or equipment.
- C. Protect all equipment, outlets and openings with temporary plugs, caps and covers. Protect work and materials of other trades from damage that might be caused by work or workmen and make good damage thus caused.
- D. When open flame or spark producing tools such as blow torches, welding equipment, etc., are required in the process of executing the work, the General Contractor will be notified not less than twenty-four (24) hours in advance of the time that the work is to begin and the location where the work is to be performed. Provide, where necessary, fire protective covering and maintain a constant non-working fire watch where work is being performed and until it is completed.

1.19 COOPERATION WITH OTHER TRADES

- A. Give full cooperation to other trades and furnish in writing to the Architect any information necessary to permit the work of all trades to be installed satisfactorily and with the least possible interference or delay.
- B. Coordination drawings shall be initiated under Section 23.00.00 of the Specifications. It is

their responsibility for preparation of project coordination drawings showing the installation of all equipment, piping, ducts and accessories to be provided under Section 23.00.00 of the Specifications. These drawings shall be prepared at not less than 3/8 in. = 1 ft. scale, and shall show building room layouts, structural elements, ductwork and lighting layouts of function. A reproducible copy of each drawing prepared shall then be submitted to each Contractor working under Sections 21.00.00, 22.00.00 and 26.00.00, who shall be responsible to coordinate his equipment and systems and shall show these on the drawings submitted. After this Contractor has fulfilled his obligation, he shall return the drawings to the HVAC Contractor. After each drawing has been coordinated between trades, each trade shall sign each drawing, indicating acceptance of the installation. The HVAC Contractor shall then print the coordination original and these prints submitted through the General Contractor to the architect for review and comment, similar to shop drawings. Comments made on these drawings shall result in a correction and re-submittal of the drawings.

- C. Furnish to other trades, as required, all necessary templates, patterns, setting plans, and shop details for the proper installation of work and for the purpose of coordinating adjacent work.
- D. The Coordination Drawings shall be produced on AutoCAD Release 2006 minimum or compatible system. A disc and one (1) set of reproducible sepias (all-trade composite) shall be provided to the Architect/Engineer for review.
- E. Coordination Drawings shall not be construed as replacing any Shop Drawings.
- F. The Plumbing Subcontractor shall be additionally responsible for preparing drawings indicating all the buried or underground plumbing systems. Include in these documents all other underground components such as, but not limited to, underslab drainage systems, foundation drainage systems, footings, foundation walls, pits, tie beams, electric and telephone duct banks.

1.20 CONTINUITY OF SERVICE AND SCHEDULING OF WORK

- A. Continuity of all services shall be maintained in all areas which will be occupied during the construction period. When an interruption of service becomes necessary, such shall be made only upon consent of the Owner and at a time outside normal working hours as he shall designate.
- B. Refer to the overall scheduling of the work of the project. Schedule work to conform to this schedule and install work to not delay nor interfere with the progress of the project.

1.21 ACCESSIBILITY

- A. Assure and be responsible for the adequacy of shafts and chases, the adequate clearance in double partitions and hung ceilings for the proper installation of the work. Cooperate with all other trades whose work is in the same space. Such spaces and clearances shall, however, be kept to the minimum size required.
- B. Locate all equipment, which must be serviced, operated, adjusted or maintained fully accessible positions. Equipment shall include, but not be limited to, valves, traps, cleanouts, motors, controllers, filters, dampers, starters, coils, fire dampers, smoke dampers and drain points. If required for better accessibility, furnish access doors for this purpose. Minor deviations from drawings may be made to allow for better accessibility, and the engineer shall approve any change.
- C. Provide access panels for installation in concrete block walls or gypsum wallboard ceilings and partitions in locations, which require access for service to the items located behind the permanent gypsum wallboard or concrete block finish.
- D. Access panels shall be installed where required to gain access to valves, dampers, controls, etc. Panels shall be flush, insulated, contain continuous steel hinge and screwdriver operated

latch. Panels shall be rated equal to the assembly that they are being installed in panels shall be UL listed.

- E. Access panels located in fire rated partitions shall be fire panels. The frame and panel assembly of these fire panels shall be manufactured under the Factory Inspection Service of the Underwriters' Laboratories, Inc., and shall bear a label reading: "Frame and Fire Panel Assembly, Rating 2 hours. (B) Temperature Rise 30 Minutes, 250° F. Maximum." Rated panels shall be equipped with automatic closing mechanism and be self-latching.
- F. Panels shall be provided with screwdriver operated flush cam locks.
- G. Panel size shall be 12 inches x 12 inches except furnish a larger size if required to service a particular item.
- H. The exact location and size of each access panel shall be noted on a shop drawing and reviewed with, and approved by, the Architect and Engineer in writing prior to installation.

1.22 SUBSTANTIAL COMPLETION

- A. When Subcontractor considers Work under this Section (or designated portion of Work) is substantially complete, submit written notice through the General Contractor with a list of items remaining to be completed or corrected.
- B. Should Architect and/or his Engineer observe and find Work is not substantially complete, he will promptly notify Subcontractor through the General Contractor in writing, listing observed deficiencies.
- C. Subcontractor shall remedy deficiencies and send a second written notice of substantial completion.
- D. When Architect and/or his Engineer finds work is substantially complete he will prepare a Certificate of Substantial Completion in accordance with provisions of General Conditions.

1.23 FINAL COMPLETION

- A. When Subcontractor considers Work under this Section is complete, submit through the General Contractor written certification that:
 - 1. Contract documents have been reviewed.
 - 2. Work has been inspected for compliance with Contract Documents.
 - 3. Work has been completed in accordance with Contract Documents and deficiencies listed with Certificate of Substantial Completion have been corrected.
 - 4. Equipment and systems have been tested, adjusted and balanced and are fully operational.
 - 5. Operation of systems has been demonstrated to Owner's personnel.
 - 6. Work is complete and ready for Architect's and/or his Engineer's final review.
 - 7. Should Architect and/or his Engineer observe and find work incomplete, he will promptly suspend his review and notify Subcontractor in writing through the General Contractor.
 - 8. Subcontractor shall complete his work, remedy deficiencies and send a second certification of final completion.
 - 9. Architect and/or his Engineer shall, upon receipt of a second certification of completion, make a second review and shall notify the Subcontractor in writing through the General Contractor listing observed deficiencies.
 - 10. When Architect and/or his Engineer finds work complete, he will consider close out submittals.

1.24 REOBSERVATION

- A. Should status of completion of Work require additional services by Architect and/or his Engineer due to failure of Work to conform with Subcontractor's claims on initial Architect and/or Engineer's review for Substantial Completion or for Final Completion, Owner will deduct the amount of Architect and/or his Engineer's compensation for additional services from final payment to Subcontractor.

1.25 CERTIFICATES OF APPROVAL

- A. Upon completion of all work, furnish in duplicate certificates of inspections from all inspectors and authorities having jurisdiction, notarized letters from the manufacturers stating that authorized factory engineers have inspected and tested the operation of their respective equipment and found same to be in satisfactory operating condition.

1.26 INSPECTION AND TEST

- A. If inspection of materials and/or equipment installed shows defects, such defective materials and/or equipment shall be replaced at no cost to the General Contractor or Owner, and the inspection and tests repeated.
- B. Make all reasonable tests as required and prove the integrity of all work and leave the entire installation in correct adjustment and ready to operate.

1.27 MATERIALS AND EQUIPMENT STANDARDS

- A. Where materials or equipment are specified by patent proprietary name or name of the manufacturer, such specification shall be deemed to be used for the purpose of establishing a standard for that particular item. No equipment or material shall be used unless previously approved by the Architect.
- B. Substitutions may be offered for review provided the material, equipment or process offered for consideration is equal in every respect to that indicated or specified and only if the term "approved equal" appears. The request for each substitution must be accompanied by complete specifications together with drawings or samples to properly appraise the materials, equipment or process.
- C. If a substitution of materials or equipment in whole or in part is made, the Contractor shall bear the cost of any changes necessitated by any other trade as a result of said substitution.
- D. Manufacturer's directions shall be followed in the delivery, storage and installation of any equipment. Notify the Architect/Engineer, in writing, of any conflict between the Contract Drawings and the manufacturer's requirements and obtain a written response prior to proceeding with work. Should the Subcontractor fail to comply with this, he/she shall bear the costs of any corrections which may be required.
- E. The Subcontractor shall furnish and install all equipment, accessories, connections and incidentals to complete the work under this Section.
- F. As of January 4, 2014; all products installed associated with any plumbing system utilized to convey potable drinking water shall comply with the Reduction of Lead in Drinking Water Act.

1.28 CONFLICT BETWEEN PLANS AND SPECIFICATIONS

- A. In case of conflict between the contract drawings and specifications, the Engineer shall determine which takes precedence.

PART 2 -- PRODUCTS

2.1 PIPE AND FITTINGS

- A. Pipe and fittings shall be of US manufacture and shall conform to the latest ANSI, ASTM, AWWA and NFPA Standards including latest amendments.
- B. Each length of pipe, each pipe fitting, trap, material and/or device used in the respective system shall have cast, stamped or indelibly marked on it, the maker's name or mark, weight

and quality of the product when such marking is required by the approved standard that applies.

- C. Type A:
Cement lined ductile iron, Class 52, mechanical joint ductile iron fittings conforming to AWWA Class D. Pipe and fittings shall be 350 psi rated. Pipe and fittings shall be cement lined on the inside and bituminous coated on the outside. Changes in direction shall have tie rods anchored to concrete thrust blocks.
- D. Type B:
Corzan CPVC Schedule 80 Pressure Pipe and Fitting System
All pipe and fittings shall be supplied as a system by a single manufacturer.
Pipe and fittings shall be joined by a two step solvent cement and be chemical compatible with the associated plastic pipe material and comply with the FBC System Compatible Program.
All pipe and fittings shall be labeled and listed for plenum.
Installation to be in compliance with manufacturer's instructions.
All installers shall be trained on the use and installation of the system by a Lubrizol manufacturer's representative. Certification shall be furnished as part of the submittal process confirming that all users have been trained and certified.
- E. Type C:
Type L hard drawn copper tubing with wrought copper sweat fittings joined with approved 95/5 lead free tin antimony solder.
And / Or
Type L hard drawn copper tubing joined with press fittings including a factory installed sealing element made of EPDM (Black), 420 stainless steel grip ring, separator ring, and an unpressed fitting leak identification feature.
Installation must be in accordance to manufacturer's instructions and specifications.
Contractor shall be trained on the use and installation of the system by manufacturer's representative.
- F. Type D:
PVC Schedule 40 solid wall pipe and PVC drainage fittings joined by solvent welding.
This system is intended for use in non-pressure applications where the operating temperature will not exceed 140° F.
PVC cellular core pipe and PVC drainage fittings joined by solvent welding will not be approved as an equal.
All buried piping shall be provided with an electrically continuous corrosion resistant yellow tape marker and tracer wire (minimum AWG 14) to facilitate locating.
Vent through roof shall terminate utilizing no hub cast iron soil pipe and fittings.
- G. Type E:
Service weight hub and spigot cast iron soil pipe and fittings joined with neoprene resilient gaskets.
Pipe and fittings shall be marked with the Collective Trademark of the Cast Iron Soil Pipe Institute (CISPI) and be listed by NSF International.
- H. Type F:
PVC Schedule 40 solid wall pipe with integral bell and factory installed gasket system.
- I. Type G:
Type DWV hard drawn seamless copper tubing with wrought copper drainage fittings joined with 95/5 lead free tin antimony solder.
- J. Type H:
PVC Schedule 40 perforated wall pipe and PVC drainage fittings joined by solvent welding.

This system is intended for use in non-pressure applications where the operating temperature will not exceed 140° F.

PVC cellular core pipe and PVC drainage fittings joined by solvent welding will not be approved as an equal.

All buried piping shall be provided with an electrically continuous corrosion resistant yellow tape marker and tracer wire (minimum AWG 14) to facilitate locating.

- K. Type I:
Type K hard drawn copper tubing with brazed wrought copper, listed or approved fittings made especially for brazed connections.
- L. Type J:
Schedule 40 black steel pipe with standard weight malleable iron fittings joined with threaded connections.
And / Or
Schedule 40 black steel pipe with press fittings including a factory installed sealing element made of HNBR (Yellow), 420 stainless steel grip ring, separator ring, and an un-pressed fitting leak identification feature.
Installation must be in accordance to manufacturer's instructions and specifications.
Contractor shall be certified on the use and installation of the system by manufacturer's representative. Certification shall be furnished as part of the submittal process confirming that all users have been trained and certified.
- M. Type K:
Schedule 40 black steel pipe with beveled ends with standard weight carbon steel beveled end fittings joined by welding in accordance with local codes.
And / Or
Schedule 40 black steel pipe with press fittings including a factory installed sealing element made of HNBR (Yellow), 420 stainless steel grip ring, separator ring, and an un-pressed fitting leak identification feature.
Installation must be in accordance to manufacturer's instructions and specifications.
Contractor shall be certified on the use and installation of the system by manufacturer's representative. Certification shall be furnished as part of the submittal process confirming that all users have been trained and certified.
- N. Joints between different piping materials shall be made with a mechanical joint or dielectric fitting.
- O. Pipe and fittings shall be in accordance with the following:
- | | |
|---|--------|
| 1. Exterior Water Service | Type A |
| 2. Cold Water | Type B |
| 3. Hot Water Supply and Recirculation | Type B |
| 4. Non-potable cold water | Type B |
| 5. Non-potable hot water supply and recirculation | Type B |
| 6. All water piping systems serving water heaters and within mechanical room. | Type C |
| 7. Sanitary, Waste and Vent Inside Buried | Type D |
| 8. Sanitary, Waste and Vent Within the Building | Type D |
| 9. Waste and Vent 1 1/2 inches and Smaller | Type D |
| 10. Primary Storm Drainage Inside Buried | Type D |
| 11. Primary Storm Drainage Within the Building | Type D |
| 12. Secondary Storm Drainage Within the Building | Type D |
| 13. Kitchen Waste and Vent Inside Buried | Type E |
| 14. Mechanical Room Waste Inside Buried | Type E |
| 15. Sanitary from Last Building Cleanout to 5'-0" beyond Foundation Wall | Type F |
| 16. Kitchen Waste from Last Building Cleanout | |

to 5'-0" beyond Foundation Wall	Type F
17. Primary Storm Drainage from Last Building Cleanout to 5'-0" beyond Foundation Wall	Type F
18. Kitchen Waste and Vent 1 1/2 inches and Smaller	Type G
19. Underslab and Foundation Groundwater Drainage Buried	Type H
20. Elevator Waste Pump Discharge Pressure Portion Within Elevator Shaft	Type I
21. Elevator Waste Pump Discharge Pressure Portion Within Building	Type I
22. Natural Gas 2 inches and Smaller	Type J
23. Natural Gas 2 1/2 inches to 4 inches and Larger	Type K
24. Water Heater Relief Valve Discharge	Type C
25. Indirect Waste Piping 1 inch and smaller	Type C
26. Indirect Waste Piping 1-1/4 inch and larger	Type G

2.2 WATER METER

- A. Furnish and install one (1) domestic water meter at the entrance of the domestic water service into Building and additional meters as dictated in this article in accordance with the following:
- B. Meter shall be approved equal with one-piece bronze case, bronze measuring chamber and ASME flanges to match incoming line size. Meter register shall be compatible with water department specification.
- C. Meter shall conform with all rules and regulations of all Authorities having jurisdiction and shall comply with the latest Standards of American and New England Water Works Association, obtain approval and installation requirements of the Local Water Department prior to ordering or installation of meters.
- D. The meter shall be the remote reading type and shall conform with all rules and regulations of all Authorities having jurisdiction. Obtain approval of the Local Water Department prior to ordering or installation of remote read device. Remote read device shall be mounted in an acceptable location as determined by the Local Water Department.
- E. Each bidder for work under this Section of the Specification shall include in his base bid all cost involved in furnishing and installing meter. Shut-off valves shall be installed on both sides of the meter. The installation shall follow the instructions set forth in manufacture's installation specifications.

2.3 VALVES

- A. Shut off valves at water meter shall be Apollo 610F flanged ends, iron body bronze mounted, solid wedge, inside screw, non-rising stem, 200 psi WOG.
- B. Shutoff valves on water piping 1/2 inch through 2 1/2 inch shall be Apollo 77LF series, lead free, bronze body ball valve, full port, chrome plated bronze ball, 600 psi WOG.
 - 100 = threaded
 - 200 = sweat
- C. Corzan CPVC Schedule 80 Pressure Pipe and Fitting System Shutoff valves on water piping 1/2 inch through 2 1/2 inch shall be Apollo 77LF-100 threaded series, lead free, bronze body ball valve, full port, chrome plated bronze ball, 600 psi WOG.
- D. Pressfit check valves on water piping 1/2 inch through 2 inch shall be Apollo 61LF series, leaf free, bronze body, with a factory installed sealing element made of EPDM, bronze check valve, stainless steel spring check, bubble tight and 300 WOG.
- E. Hot water flow splitter shall be Kemper Water Controls Systems 651 Series with shutoff valves, female threads and insulation shell.

- F. Balancing valve assembly for hot water recirculation shall be as manufactured by Therm Omega Tech Product
 - 1. Balancing valve assembly 1/2 inch to 1 inch shall be Circuit Solver Assembly CSUA series self adjusting lead free thermostatic balancing valve with integral inlet / outlet isolation valves and check valve.
 - 2. CircuitSolver selection shall satisfy the hot water design temperature. CircuitSolver is fully open approximately 10°F below the closing temperature. Typical closing temperatures include: 120°F and 140°F.
- G. All ball valves for installation in insulated piping shall have valve extensions to suit installation thickness.
- H. Shut-off valves on natural gas system 1 1/2 inches and smaller shall be Apollo Series 70-100-07, threaded bronze ball valve, 600 psi WOG. Shut-off valves on natural gas systems 2 inches and larger shall be Rockwell Fig. 143, semi-steel, lubricated plug valves, flanged ends, wrench operated, 200 psi WOG.
- I. Backflow preventers 2 inches and smaller shall be reduced pressure principle, all bronze Watts Series LF909-QT-S for cold water and hot water including bronze strainer, valves, air gap fittings test cocks and spare parts kit. Each backflow preventer and shut-off valves shall be installed between 3 and 4 feet above the floor and a minimum of 12 inches from any wall. Support the assembly from the floor or the wall. Run vent to nearest floor drain or similar open receptor. Pressure gauges shall be installed on the supply and discharge side of each backflow preventer assembly. Each pressure gauge assembly shall include TRERICE 600-C gauge, 3-1/2 inch diameter size, 0-160 psi dial range, 735-2 valve and 872-1 snubber. Furnish to the Owner one Watts TK-99 E Test Kit. This Contractor shall act as the Owner's agent in seeking approval from the Department of Environmental Protection or its designee. This Contractor shall submit all plans, specifications and applications required for approval and shall pay all fees. Approvals shall be secured prior to the purchase and installation of backflow preventers. Test and certify backflow preventer.

Provide Watts LFF113FP flood protection shutdown valve.

This Plumbing Sub-Contractor shall make special provisions that testing and certification of the backflow preventers are performed by a Providence Water Supply Board Certified Tester.

2.4 EXTERIOR FOODSERVICE EQUIPMENT CONTROLS

- A. Outdoor Control
 - 1. Gas Safety Control Panel. Provide UL Listed to 61010 control panel with clear status display and key lock authority re-set function. Control panel should be recessed wall mounted 10in x7in x3in enclosure. Panel to energize solenoid valve via keyed authority switch, Fascia mounted panic button or remote emergency stop button shall de-energize solenoid and will require authority key re-set. All alarm conditions will be clearly visible from the fascia mounted LED display. Panel shall include built in connectivity to remote emergency stop button and building management system / fire alarm control panel. Coordinate location of control panel with the plans and the owner in the field. Provide 3yr manufacturer warranty. Basis of design American Gas Safety Merlin 1000Si or approved equal.
 - 1. Timer. Provide UL Listed 7-day electronic timer, capable of permitting up to 28 setpoints or events weekly. The time switch shall provide a minimum ON or OFF time of 1 minute. Time switch to be powered by 120VAC,50 Hz power supply. The time switch mechanism shall be a snap-in design to provide easy mechanism removal for mounting the enclosure. The time switch enclosure shall be a Type 1 steel lockable enclosure that shall

be painted with an electrostatic process to eliminate the potential for corrosion. The time switch shall provide clear terminal identification on a non-curling terminal insulator. A visual indicator shall be provided in the time switch for indicating output load status. Terminal connections shall be made using teeter-type terminal screws to provide secure connections for wire sizes up to #10 AWG. Switch configuration shall be SPST with a UL or CSA listed switch rating of: 30amps @120vac. Locate timer adjacent to Merlin 1000Si control panel and where shown on plans. Provide 3yr manufacturer warranty. Basis of design American Gas Safety AGSPGT7M or equal.

2. Solenoid Valve. Provide UL Listed 429, CSA Certified, FM 400 liquid or gas safety shut-off valve. Aluminum body two-way normally closed valve rated for natural gas (methane) and LPG. Size to be same as pipe size indicated on plans, 120 volt ac 50/60HZ single phase actuator, and 2 PSI maximum operating pressure. Basis of design American Gas Safety (AGS) series MERLIN1031 or equivalent. Division 22 to install inline quarter turn isolating valves with handles and strainers were required by these plans or local code. Locate valve as per drawings.
3. Remote Emergency Push Button. Provide a UL listed, ADA Approved, wall mounted with single gang rough in box. Yellow enclosure with clear plastic shield cover labeled "Emergency Gas Shut-off". Red mushroom emergency stop button, push to activate / twist-pull to re-set. Provide with clear plastic weatherproof lift up shield. Wire button in volt free dry contact control circuit to Merlin Gas Control Panel as per manufacturers instructions. Furnished by Division 22 installed by Division 26. Provide 3yr manufacturer warranty. Basis of design American Gas Safety (AGS) Series AGSEGOTWWM rated for exterior applications or approved equal.

2.5 BACKWATER VALVES

- A. Backwater valves shall be as manufactured by Josam Manufacturing Company, Jay R. Smith Manufacturing Company, Zurn Industries, Inc. or approved equal.
- B. Backwater valve shall be Spears SML-4XP-A 4 inch PVC with EPDM valve seats. Valves shall have external arrow flow indicator.

2.6 HEAT TRACING

- A. **Temperature Maintenance Cable**
120°F at 120 volt

Domestic hot water supply temperature maintenance cable shall be Heat Trace Products 2708-13N self regulating heating cable with an operating voltage of 120 at 08 watts per foot and 20 Amp breaker size. Include all appurtenant hardware, power connection kit, end termination, adjustable thermostat, fiberglass attachment tape, and electric trace label. The system shall maintain 120° F.

2.7 INSULATION

- A. Insulation shall be Owens Corning Insulating Systems
- B. General:
 1. Products shall not contain asbestos, lead, mercury, or mercury compounds.
 2. Owens Corning pipe insulation is not known to contain penta-, octa-, or deca-brominated diphenyl flame retardant substances, such as deca-Bromine (deca-BDE).
 3. Insulation materials for use on austenitic stainless steel shall be qualified as acceptable according to ASTM C795.
- C. Certifications:
 1. Only Owens Corning SSL II with ASJ Max and VaporWick pipe products are

GREENGUARD Indoor Air Quality Certified and GREENGUARD Gold Certified.

2. Owens Corning pipe products are certified by SCS Global Services to contain a minimum of 53% recycled glass content, 31% pre-consumer and 22% post-consumer (except Flexwrap Insulation).
3. Owens Corning pipe products are UL listed and labeled (except Flexwrap Insulation and Pipe and Tank Insulation).
4. No Wrap FIBERGLAS Pipe Insulation and Jacketed FIBERGLAS Pipe Insulation (ASJ Max, VaporWick, Evolution, ASJ) have received the Cradle to Cradle Products Innovation Institute's Bronze Level Material Health Certificate.
5. These products Environmental Product Declaration (EPD) has been certified by UL Environment.
6. Molded Fibrous Glass Pipe Insulation: Comply with ASTM C547, Type I, Grade A; and Type IV, Grade B; and ASTM C585, for sizes required and of a type suitable for installation on piping systems as required. One of the following types shall be used:
 - a. For indoor systems operating at temperatures from 0°F (-18°C) to +1000°F (538°C) with heat-up schedule:
 - I. Owens Corning® SSL II® with ASJ Max FIBERGLAS Pipe Insulation.
 - b. For systems operating at temperatures up to +850°F (232°C), no heat up-schedule required.
 - c. For systems operating at temperatures to +1000°F (538°C) with heat-up schedule and always above the ambient temperature:
 - I. Owens Corning No Wrap Pipe Insulation.
7. For systems operating below ambient (32°F (0°C) to +65°F (18°C)) temperature:
 - a. Owens Corning VaporWick® Pipe Insulation. (see Plumbing Pipe Insulation – VaporWick® Pipe Insulation)
8. Perpendicular Oriented Mineral Fiber Insulation: ASTM C1393, Type IIIB, Category 2:
 - a. For piping equal to or larger than 10 in (250 mm) diameter operating at temperatures up to +850°F (454°C):
 - I. Owens Corning Flexwrap FIBERGLAS Insulation.
9. Perpendicular Oriented Mineral Fiber Insulation: ASTM C1393, Type II, Category 1:
 - a. For piping equal to or larger than 10 in (250 mm) diameter operating at temperatures up to +650°F (343°C):
 - b. Owens Corning® FIBERGLAS Pipe and Tank Insulation.
10. Provide accessories per insulating system manufacturer's recommendations, including the following:
 - a. Closure Materials: Butt strips, bands, wires, staples, mastics, adhesives, and pressure-sensitive tapes. a. Mold resistant mastics are recommended for chilled water applications.
 - b. Field-Applied Jacketing Materials: Sheet metal, plastic, canvas, fiberglass cloth, insulating cement, PVC fitting covers.
 - c. Support Materials: Hanger straps, hanger rods, saddles, support rings, and high density inserts.
 - d. Adhesives For Indoor Applications: VOC content of 50 g/L or less when calculated according to 40 CFR 59, Subpart D (EPA Method 24).
11. Insulation shall be in accordance with the following schedule:

<u>System</u>	<u>Insulation Thickness</u>
Cold Water 1/2 " through 1-1/4"	1/2" thickness
Cold Water 1-1/2" through 6"	1" thickness
Hot Water 1/2" through 1-1/4"	1" thickness
Hot Water 1-1/2" through 6"	1-1/2" thickness
Solar Water Supply	2"
Solar Water Return	2"
Horizontal Rain Leader including Drain Body and Bend into Vertical	1/2" up to 6" diameter 1" above 6" diameter
Horizontal Secondary Rain Leader Including Drain Body and Bend into Vertical	1/2" up to 6" diameter 1" above 6" diameter

Domestic Water CPVC and Corzan piping shall be insulated in its entirety.
2015 International Energy Conservation Code does not address pipe material.

2.8 HANGERS AND SUPPORT

- A. Pipe hangers, pipe anchors, auxiliary steel, wood blocking and fixture supports shall be furnished and set by this Contractor, and he shall be responsible for their proper and permanent location. This Contractor shall be responsible for all core drilling.
- B. All piping shall be rigidly supported from the building structure by means of approved hangers and supports. The hanging and support of all piping system shall conform to the ANSI/MSS-SP.58 AND MSS-SP 69 latest edition. This Contractor shall furnish and install all required auxiliary steel required for hanging of piping.
- C. All horizontal piping shall be hung with approved adjustable malleable iron pipe hangers.
 1. Copper tubing 1-1/2 inch and larger shall be supported at ten (10) foot intervals. Copper tubing 1-1/4 inch and smaller shall be supported at six (6) foot intervals.
 2. Steel piping shall be supported at six (6) foot intervals for piping 1/2 inch and smaller, at eight (8) foot intervals for 3/4 inch and one inch piping and at ten (10) foot intervals for piping 1-1/4 inch and larger.
 3. Plastic piping shall be supported at 3 foot intervals for 1-1/4 inch piping and smaller, 4 foot intervals for 1 1/2 inch piping and larger.
- D. Vertical hangers
 1. Steel piping shall be supported at each story height and at not more than ten (10) foot intervals.
 2. Copper tubing shall be supported at each story height and at not more than ten (10) foot intervals.
 3. Plastic piping shall be supported at each floor.
- E. Roof Support
 1. Horizontal piping support system for piping installed on roof shall be Dymotek Corporation Roof Top Blox UV resistant HDPE resin with foam base and all required accessories required for a complete installation.
- F. Interior hangers for piping sizes four (4) inches and smaller shall be Carpenter & Paterson, No. 1A band type, Grinnell Company, Calco Steel Products Company or equal, black steel with hanger rods with machine threads. Hangers for piping larger than four (4) inches shall be the adjustable clevis hanger type, malleable iron with extension rod. Chain, strap, perforated bar or wire hangers will not be approved. Where used for uninsulated copper tubing, all hangers shall be copper plated and chrome plated for chrome plated piping. Insulation shields shall be provided on all horizontal insulated piping at each hanger or support location.

- Insulation shields shall be galvanized steel, 180 degrees arc and centered on the hanger or support. On diameters 4 inches and smaller, shield shall be 12-inch long, 18 gauge steel. On diameters 5 inches and 6 inches, shield shall be 18-inch long, 16 gauge steel. On diameters 8 inches and 10 inches, shield shall be 24-inch long, 14 gauge steel. On diameters greater than 10 inches, shield shall be 24-inch long, 12 gauge steel. Structure attachments shall be as manufactured by Carpenter & Patterson and shall be suitable to carry the weight.
- G. Approved gang hangers may be used in lieu of separate hangers on pipes running parallel to each other and close together.
 - H. All fixtures and equipment shall be supported and fastened in a satisfactory manner and in accordance with fixture manufacturer's recommendations.
 - I. Where chair carriers are required, they shall be completely concealed in the building construction and shall rigidly support the fixture from the floor. Chair carrier shall support fixtures in such a manner that no part of the fixture will be supported by the wall or partition. Chair carriers shall be furnished complete with necessary bolts, nuts and washers as well as connecting nipples of the proper length with gaskets for the fixture connection. All available or optional anchor foot assemblies shall be utilized. Carriers must fit in available space and shall be of the special narrow type or compact style where necessary. Chair carriers for water closets and urinals shall include flushometer supply pipe support. Flushometer supply pipe shall always be provided with a concealed support regardless of if the design includes a carrier or not.
 - J. Wherever wood blocking is required to insure adequate support of fixtures and related piping, it shall be provided by this Contractor and it shall be fire treated.
 - K. All inserts in new concrete construction shall be capable of developing the full strength of the rod or bolt used in them and shall be either continuous insert type or malleable iron concrete inserts for rod sizes 3/8 inch to 7/8 inch. Continuous inserts shall have anchors every 4 inches and shall extend 1-1/2 inches above the back of the insert and shall hook to provide anchor. All inserts shall be tied to the reinforcing steel rods with wire and properly sized reinforcing rods shall be inserted through the special holes, hooks or brackets provided in or on the inserts to securely anchor insert to the structure.
 - L. Seismic Restraints: It is the intent of this seismic specification to keep all mechanical building system components in place during a seismic event.
 - 1. All mechanical systems must be installed in strict accordance with seismic codes, component manufacturer's and building construction standards. Whenever a conflict occurs between the manufacturer's or construction standards, the most stringent shall apply.
 - 2. This contractor shall engage a professional structural engineer registered in the jurisdiction of this project to review the entire installation to determine all seismic restraint requirements and methods. Contractor shall submit a report outlining the structural engineer's review as well as seismic restraint shop drawings and supporting calculations prepared by the professional structural engineer for review by the Architect.
 - 3. Seismic restraints shall be designed in accordance with seismic force levels as detailed in the applicable building code.

2.9 SLEEVES, ESCUTCHEONS AND FIRESTOPPING

- A. Sleeves shall be furnished and set by this Contractor and he shall be responsible for their proper and permanent location. This Contractor shall be responsible for all core drilling. Core openings shall have link-seal fire-rated penetration closures.
- B. This Contractor shall provide steel sleeves at all points where pipes and all other work under his charge pass through masonry, concrete or wood. Sleeves shall have flanges or wings at mind-points to prevent sleeve from slipping through the floor or wall. Pipe sleeves shall be sufficient diameter to provide approximately 1/4 inch clearance around the pipe or the insulation on insulated systems. Sleeves through walls shall end flush with the surface of the

- walls. Sleeves in floors shall extend one inch above the floor and after installation of piping shall be packed, firestopped and made watertight. Sleeves in exterior walls shall have waterstop plates, shall end flush with the surface of the walls, shall have link-seal penetration closures and shall be of a diameter that is compatible with the Link Seal System.
- C. Seal the sleeve penetrations with firestopping and smoke stopping systems as manufactured by Dow Corning, Bio-Shield, Rectorseal Metacaulk, 3M, Fyre Putty or equal. Where pipes penetrate fire rated construction, the openings shall be packed with the material and system that shall maintain the integrity of the fire rating as detailed in the UL Fire Resistance Directory.
 - D. Firestop sealant shall be chemical compatible with the associated plastic pipe material and comply with the FBC System Compatible Program.
 - 1. Note: Refer to architectural drawings for rated walls and partitions. Where there are no architectural drawings or they do not indicate rated walls and partitions, the following guidelines shall be used. All floors, corridor walls, party walls, mechanical room walls, duct and pipe chase walls, stairwells, trash room and chute walls shall be considered minimum two hour fire rated walls.
 - E. Plastic piping including CPVC, PEX and PVC pipe fire rated penetrations.
 - 1. General
 - a. Provide through-penetration firestop systems that are compatible with one another, with the substrates forming openings, and with the items, if any, penetrating through-penetration firestop systems, under conditions of service and application, as demonstrated by through-penetration firestop system manufacturer based on testing and field experience.
 - b. Provide components for each through-penetration firestop system that are needed to install fill materials. Use only components specified by the firestopping manufacturer and approved by the qualified testing agency for the designated fire-resistance-rated systems.
 - 2. Acceptable Manufacturers
 - a. Subject to compliance with through-penetration firestop systems (XHEZ) listed in Volume 2 of the UL Fire Resistance Directory, provide products of the following manufacturers as identified below:
 - 1) Acceptable Manufacturer: Specified Technologies Inc.
 - 2) Substitutions: Not permitted.
 - 3) Single Source: Obtain firestop systems for each type of penetration and construction condition indicated only from a single manufacturer.
 - 3. Materials
 - a. Use only firestopping products that have been tested for specific fire-resistance-rated construction conditions conforming to construction assembly type, penetrating item type or joint opening width and movement capabilities, annular space requirements, and fire-rating involved for each separate instance.
 - b. Intumescent Sealants: Single component intumescent latex formulations containing no water soluble intumescent ingredients capable of expanding a minimum 8 times, the following products are acceptable:
Specified Technologies, Inc. (STI) SpecSeal Series SSS Intumescent Sealant
Specified Technologies, Inc. (STI) SpecSeal Series LCI Intumescent Sealant
 - c. Endothermic Sealants: Single component latex formulations that upon cure do not re-emulsify during exposure to moisture, the following products are acceptable:
Specified Technologies, Inc. (STI) SpecSeal Series LC Endothermic Sealant

- d. Elastomeric Sealants: Single component latex formulations that upon cure do not re-emulsify during exposure to moisture and accommodate minimum ± 25 percent movement, the following products are acceptable:
Specified Technologies, Inc. (STI) SpecSeal Series AS Elastomeric Spray
Specified Technologies, Inc. (STI) SpecSeal Series ES Elastomeric Sealant
- e. Firestop Devices: Factory-assembled steel collars lined with intumescent material capable of expanding a minimum 30 times sized to fit specific outside diameter of penetrating item, the following products are acceptable:
Specified Technologies, Inc. (STI) SpecSeal Series SSC Firestop Collars
Specified Technologies, Inc. (STI) SpecSeal Series LCC Firestop Collars
- f. Wall Opening Protective Materials: Intumescent, non-curing pads or inserts for protection of electrical switch and receptacle boxes to reduce horizontal separation to less than 24" (610 mm), the following products are acceptable:
Specified Technologies, Inc. (STI) SpecSeal Series SSP Firestop Putty Pads
Specified Technologies, Inc. (STI) SpecSeal Series EP PowerShield Insert Pads
- g. Firestop Putty: Intumescent, 100% solids, non-hardening, water resistant, butyl rubber based putties containing no solvents or silicone compounds, the following products are acceptable:
Specified Technologies, Inc. (STI) SpecSeal Series SSP Firestop Putty
- h. Wrap Strips: Single component intumescent elastomeric strips faced on both sides with a plastic film and capable of expanding a minimum 30 times, the following products are acceptable:
Specified Technologies, Inc. (STI) SpecSeal Series RED2 Wrap Strip
Specified Technologies, Inc. (STI) SpecSeal Series BLU2 Wrap Strip
- i. Mortar: Portland cement based dry-mix product formulated for mixing with water at Project site to form a non-shrinking, water-resistant, homogenous mortar, the following products are acceptable:
Specified Technologies, Inc. (STI) SpecSeal Series SSM Firestop Mortar
- j. Silicone Sealants: Moisture curing, single component, silicone elastomeric sealant for horizontal surfaces (pourable or nonsag) or vertical surface (nonsag), the following products are acceptable:
Specified Technologies, Inc. (STI) SpecSeal SIL300 Silicone Firestop Sealant
Specified Technologies, Inc. (STI) SpecSeal SIL300 SL Self-Leveling Silicone Firestop Sealant'
- k. All-Weather Coatings: Moisture curing, single component silicone copolymer elastomeric spray coatings for horizontal surfaces where greater water resistance is required or inclement weather is anticipated, the following products are acceptable:
Specified Technologies, Inc. (STI) SpecSeal FT305 Firestop Spray
- l. Silicone Foam: Multicomponent, silicone-based liquid elastomers, that when mixed, expand and cure in place to produce a flexible, non-shrinking foam, the following products are acceptable:
Specified Technologies, Inc. (STI) Pensil 200 Silicone Foam
- m. Cast-In-Place Firestop Device: Single component molded firestop device installed on forms prior to concrete placement with totally encapsulated, tamper-proof integral firestop system and smoke sealing gasket, the following products are acceptable:
Specified Technologies, Inc. (STI) SpecSeal CD Cast-In Firestop Device

- n. Firestop Plugs: Re-enterable, foam rubber plug impregnated with intumescent material capable of expanding minimum 10 times with expansion beginning at 350°F (177°C) for use in blank openings and cable sleeves, the following products are acceptable:
Specified Technologies, Inc. (STI) SpecSeal Series FP Firestop Plug
 - o. Fire-Rated Closet Flange Gasket: Molded, single-component, intumescent gasket for use beneath a closet flange in floor applications, the following products are acceptable:
Specified Technologies, Inc. (STI) SpecSeal Series CF34 Closet Flange Firestop Gasket
 - p. Protective Wrap: Endothermic Wrap incorporating foil scrim evaluated for protection of cable pathways, liquid fuel lines, as well as in through-penetration and membrane-penetration firestopping. Testing to incorporate protection of Electrical Metallic Tubing (EMT), Rigid Metallic Conduit (RMC), Cable Trays, single and/or multi containment liquid fuel lines. Wrap to have a maximum weight of no greater than 1.4 lbs/ft² and allow for the use of steel tie wire when installed around piping, conduits, and/or cable trays. The following products are acceptable:
Specified Technologies, Inc. (STI) E-Wrap™ Endothermic Wrap
- G. Pipe Sleeves shall be according to the following:
- 1. Sleeves on pipes passing through masonry or concrete construction shall be scheduled 40 galvanized steel pipe.
 - 2. Sleeves on pipes passing through wood or drywall partitions shall be 16 gauge galvanized steel.
- H. Whenever new penetrations to a previously poured slab are required for the installation of floor drains, shower drains, mop receptors, flush floor cleanouts or similar items of plumbing, these penetrations shall be totally sealed with a fire and water stop sealant. Sealant shall be Dow Corning fire stop sealant, Catalog No. 2000. Hourly fire rating in hours must be meet the requirements of the slab being penetrated.
- I. Provide chrome plated brass escutcheons with set screws for exposed piping in all areas. In mechanical rooms use plain brass or cast iron escutcheons suitable for painting. All escutcheons shall be sized to fit the bare pipe or insulation in a snug and neat manner. They shall be of sufficient size to cover sleeves openings for the pipes and of sufficient depth to cover sleeves projecting above floors.
- J. Bored holes within wood construction. A hole not greater in diameter than 40 percent of the stud width is permitted to be bored in any wood stud. Bored holes not greater than 60 percent of the width of the stud are permitted in nonbearing partitions or in any wall where each bored stud is doubled, provided not more than two such successive doubled studs are so bored. In no case shall the edge of the bored hole be nearer than 5/8 inch (15.9 mm) to the edge of the stud. Bored holes shall not be located at the same section of stud as a cut or notch.

2.10 BUILDING EXPANSION JOINTS

- A. Where piping crosses a building expansion joint provisions shall be made to allow for the movement of each side of the structure without adversely impacting the integrity of the piping.
- B. Piping crossing a building expansion joint shall be provided with an expansion joint as indicated in these specifications and allow for a minimum of 4x the expected maximum relative deflection between the two building sections.
- C. Piping shall be rigidly affixed to the structure on either side of the building expansion joint.
- D. Flexible connections and piping expansion joints shall be suitable for the fluid type and pressure being transferred.

2.11 CLEANOUTS

- A. Cleanouts shall be as manufactured by Josam Manufacturing Company, Jay R. Smith Manufacturing Company, Zurn Industries, Inc. or approved equal. The following series numbers are intended to establish a level of quality and comparison.
- B. Cast Iron piping shall be Jay R. Smith 4023S-F-C coated cast iron floor cleanout with nickel bronze top
- C. PVC piping shall be Jay R. Smith 4033L-F-C-XH coated cast iron floor cleanout with nickel bronze top and extra heavy gasket.

2.12 WALL HYDRANTS

- A. WH-A shall be Jay R. Smith Model No. 5509QT-SS or SE stainless steel box and cover, bronze nickel plated hydrant, bronze casing, hose connection with integral vacuum breaker, sweat inlet connection, T-handle key and adjustable wall clamp. Length to suit wall thickness. Provide with mild climate, Jay R. Smith Figure No. SAP where applicable.

2.13 FLOOR DRAINS

- A. All floor drains shall be the product of one manufacturer such as Jay R. Smith, Josam, Zurn, or approved equal.
- B. FD-A:
(Finished Areas, Toilet Rooms, Shower Rooms)
Cast iron body and flashing collar with protector cap and 5-inch nickel bronze adjustable square grate, equal to:
Concrete Floors And Tile Floors
Jay R. Smith 2005Y (cast iron pipe with no-hub fittings – square grate)
Jay R. Smith 2010C (cast iron pipe with service weight hub and spigot fittings – square grate)
Jay R. Smith 212-210-13 (PVC pipe with no-hub fittings – square grate)

Provide round funnel similar to Jay R. Smith Figure No. 3580 where applicable.
Provide 4" deep seal trap with barrier type floor drain trap seal protection device.
- C. FD-B:
(Unfinished Areas, Mechanical Rooms)
Cast iron body and flashing collar with adjustable top bar grate and sediment bucket, equal to Concrete Floors
Jay R. Smith 2360Y-S (cast iron pipe with no-hub fittings – square grate)
Jay R. Smith 2360C-S (cast iron pipe with service weight hub and spigot fittings – square grate)
Jay R. Smith 2360-LXH (PVC Schedule 40 pipe and fittings – round grate)
Provide 4" deep seal trap with barrier type floor drain trap seal protection device.
- D. Trench drain shall be Watts Dead Level P-RSP-CB624 pre-sloped polypropylene trench drain and catch basin system with polypropylene frame, UV stabilized talc-filled polypropylene channels with integral 4" no hub bottom outlets. System shall be frame-anchored, with reinforced stainless steel perforated grating, frame connectors, grate lockdowns, and construction covers.
 - TD-A: 24'-0"
 - TD-B: 7'-0"
 - TD-C: 16'-0"
 - TD-D: 6'-0"
 - TD-E: 5'-0"
 - TD-F: 13'-0"
 - TD-G: 14'-0"
 - TD-H: 3'-0"
 - TD-I: 4'-0"

2.14 ROOF DRAINS

- A. All roof drains shall be the product of one manufacturer such as Jay R. Smith, Josam, Zurn or approved equal.
- B. Combined primary and secondary roof drain shall be Jay R. Smith 1800Y-E-R-C-U-CID-CIS combined primary and secondary cast iron bodies, clamping ring with gravel stop, no hub outlet, sump receiver, under deck clamp, cast iron standpipe and vandal proof cast iron dome.
Provide Jay R. Smith 1710 expansion joint at every drain location where the drain outlet piping does not immediately offset into a horizontal position.
RD-A shall serve the primary roof drainage system.
RD-B shall serve the secondary roof drainage system.
- C. Downspout Boot: Shall be Jay R. Smith 1786-36-CA 5 inch by 4 inch cast iron downspout boot with cleanout plug.
- D. Secondary Rain Leader End Cap: Shall be Jay R. Smith Figure SQ-1-3470-BS nickel bronze nozzle and flange, stainless steel wall plate and bird screen.

2.15 PLUMBING FIXTURES

- A. Water Closet, P-1:
Fixture: American Standard Afwal 2257.101 elongated wall-hung, vitreous china, 1.6 gpf siphon jet bowl with 1-1/2 inch top spud.
Flushometer: American Standard 6066.161.002 exposed PWRX sensor flushometer with 1.6 gallon per flush and courtesy flush button.
Seat: American Standard 5901.100SS extra heavy duty elongated open front seat less cover with self-sustaining hinge.
Support: Combination drainage carrier fitting with foot support and supply pipe support.
Provide SA-A on supply piping above ceiling.
Provide white sanitary mildew resistant silicone sealant where china comes in contact with finished wall.
- B. Water Closet, P-1A:
Same as P-1 except mounted to satisfy the Americans with Disabilities Act (ADA).
Flushometer control shall be installed on wide side of water closet compartment.
- C. Water Closet, P-1C:
Fixture: American Standard Baby Devoro 2282.001 round floor mounted, vitreous china, 1.28 gpf siphon jet bowl with 1-1/2 inch top spud.
Flushometer: American Standard 6066.121.002 exposed PWRX sensor flushometer with 1.28 gallon per flush and courtesy flush button.
Seat: American Standard 5001G round open front seat less cover with self-sustaining hinge.
Support: Combination drainage carrier fitting with foot support and supply pipe support.
Provide SA-A on supply piping above ceiling.
Provide white sanitary mildew resistant silicone sealant where china comes in contact with finished wall.
- D. Urinal, P-2:
Fixture: American Standard Washbrook 6590.001 vitreous china, 0.125 gpf, washout with 3/4 inch top spud inlet and 2-inch IPS outlet.
Flushometer: American Standard 6064.013 exposed PWRX sensor flushometer with 0.125 gallon per flush and courtesy flush button.
Support: Concealed carrier with foot support and supply support to suit.
Provide white sanitary mildew resistant silicone sealant where china comes in contact with finished wall.
- E. Urinal, P-2A:
Same as P-2 except mounted to satisfy the Americans with Disabilities Act (ADA).

- F. Lavatory, P-3:
Fixture: American Standard Lucerne 0356.421 20-1/2-inch x 18-inch wall hung vitreous china, concealed arm supports and single faucet hole.
Support: Concealed arm carrier with foot support to suit.
Faucet: American Standard Nextgen Selectronic 7755.303 0.35 gpm battery powered sensor operated faucet with integral thermostatic mixing valve and external temperature control.
Miscellaneous: McGuire heavy duty polished chrome-plated cast brass loose key angle valve kits, flexible braided stainless steel risers, escutcheon. Polished chrome-plated cast brass perforated strainer with 1-1/4 inch x 1-1/2 inch polished chrome-plated cast brass adjustable "P" trap, cleanout plug, with PVC adapter extension to wall and escutcheon.
Insulation: Truebro Handi Lav-Guard antimicrobial white flexible vinyl insulation kit with foam inserts.
- G. Lavatory, P-3A:
Fixture: American Standard Lucerne 0356.421 20-1/2-inch x 18-inch wall hung vitreous china, concealed arm supports and single faucet hole.
Support: Concealed arm carrier with foot support to suit.
Faucet: American Standard Nextgen Selectronic 7755.303 0.35 gpm battery powered sensor operated faucet with integral thermostatic mixing valve and external temperature control.
Trap Primer: Jay R. Smith 2698 water saver trap primer, satin chrome plated cast bronze p-trap with ground joint connection, escutcheons, 1/2" primer tube with compression fitting connection.
Miscellaneous: McGuire heavy duty polished chrome-plated cast brass loose key angle valve kits, flexible braided stainless steel risers, escutcheon. Polished chrome-plated cast brass perforated strainer with extension to wall and escutcheon.
Insulation: Truebro Handi Lav-Guard antimicrobial white flexible vinyl insulation kit with foam inserts.
- H. Lavatory, P-3B:
Fixture: Oval insert shall be selected by Architect and provided by plumbing contractor.
Faucet: American Standard Nextgen Selectronic 7755.303 0.35 gpm battery powered sensor operated faucet with integral thermostatic mixing valve and external temperature control.
Trap Primer: Precision Plumbing Products Prime Pro Pro1-ULP500 floor drain trap primer valve where required.
Miscellaneous: McGuire heavy duty polished chrome-plated cast brass loose key angle valve kits, flexible braided stainless steel risers, escutcheon. Polished chrome-plated cast brass perforated offset strainer with 1-1/4 inch x 1-1/2 inch polished chrome-plated cast brass adjustable "P" trap, cleanout plug, with PVC adapter extension to wall and escutcheon.
Insulation: Truebro Handi Lav-Guard antimicrobial white flexible vinyl insulation kit with foam inserts.
- I. Lavatory, P-3C:
Fixture: Oval insert shall be selected by Architect and provided by plumbing contractor.
Faucet: American Standard Nextgen Selectronic 7755.303 0.35 gpm battery powered sensor operated faucet with integral thermostatic mixing valve and external temperature control.
Trap Primer: Precision Plumbing Products Prime Pro Pro1-ULP500 floor drain trap primer valve where required.
Open End Drain: 2 inch PVC open end drain with barrier type trap seal protection device, Spears 2229-015 vertical PVC ball check valve with two male adapters, 1 1/2 inch by 1 1/2 inch PVC adjustable deep seal p-trap, extension to wall and escutcheon. Piping shall connect to vertical waste pipe serving sink.

- Miscellaneous: McGuire heavy duty polished chrome-plated cast brass loose key angle valve kits, flexible braided stainless steel risers, escutcheon. Polished chrome-plated cast brass perforated offset strainer with 1-1/4 inch x 1-1/2 inch polished chrome-plated cast brass adjustable "P" trap, cleanout plug, with PVC adapter extension to wall and escutcheon.
Insulation: Truebro Handi Lav-Guard antimicrobial white flexible vinyl insulation kit with foam inserts.
- J. Hose Bibb, P-4:
Chicago Faucet 952 polished chrome-plated inside sill faucet, 3/4 inch hose thread outlet, vacuum breaker, removable loose key handle, 1/2 inch inlet and wall flange.
- K. Hose Bibb, P-4A:
Chicago Faucet 860-VOAB, 83-77ABNF, 90-LABCP polished chrome-plated single wall mounted faucet with single handle, vacuum breaker, hose bracket, 1/2 inch inlet and wall flange, 77" flexible stainless steel hose and 1.0 gpm spray nozzle.
1/2 inch inlet and wall flange.
- L. Hose Station, P-4B:
Leonard Valve Company THS-25-LF-VBD-CP-18105-HDH-N2 thermostatic hot and cold water mixing valve, 3/4" water inlets, 3/4" outlet, two stop and check valves with color coded heat resistant handles on inlets, heat resistant temperature adjusting lever, integral wall support, outlet with dial thermometer, vacuum breaker, hose connection, stainless steel hose rack, mounting plate, 50'-0" heavy duty hose and nozzle.
- M. Hose Station, P-4C:
Leonard Valve Company SS-HA-1 single temperature stainless steel hose station, 3/4" water inlet, 3/4" outlet, stop and check valves with color coded heat resistant handles on inlets, heat resistant temperature, integral wall support, outlet with dial thermometer, vacuum breaker, hose connection, stainless steel hose rack, mounting plate, 50'-0" heavy duty hose and nozzle.
- N. Mop Receptor, P-5:
Fixture: Fiat Products Model MSB-2424, 24 inches by 24 inches by 10 inches high one piece molded stone complete with integral 3 inch stainless steel drain body, strainer, stainless steel wall guard, bumper guards on all exposed sides, hose with bracket and mop hanger.
Faucet: Speakman SEF-9000-ACK-TW-RCP sink fitting with vacuum breaker, check valves, hose threads, pail hook, wall brace, four arm handles, wall mounted eye wash with two spray heads, stay open ball valve and thermostatic mixing valve. Provide SA-A on supply pipe piping between faucet and thermostatic mixing valve. The shut-off valves serving the cold water and hot water supply piping serving this fixture shall be provided with a lockout cover device to prevent the unauthorized shutdown of services. Pad locks shall be the breakaway type for quick access during an emergency.
- O. Drinking Fountain, P-6:
Fixture: Halsey-Taylor HTHB-OVLSER-I hydroboost bottle filling station with integral stainless steel twin oval receptors, bi-level handicapped and standing heights with mounting frame, semi-circular 180 degree push bar and flow at 0.43 gpm in compliance with WaterSense.
Miscellaneous: McGuire heavy duty polished chrome-plated cast brass loose key angle valve kit, flexible braided stainless steel risers, two 1-1/4 inch x 1-1/2 inch cast brass adjustable "P" trap, cleanout plug, extension to wall with escutcheon.
- P. Sink, P-7:
Fixture: Elkay DLR-172210PD stainless steel insert single-compartment 17 inches by 22 outside dimension by 10 inches deep, 18-gauge with type 302 stainless steel with one (1) faucet hole on center.

Faucet: Elkay LKD2443C hi-arc deck mounted faucet with gooseneck spout, 4 inch wrist blade handles and retractable spray and hose.

Drain and Tailpiece: Elkay LK-99 basket strainer and 1-1/2 inch tailpiece.

Solids Interceptor: Striem Sidekick PVC solids interceptor with perforated basket.

Open End Drain: 2 inch PVC open end drain with barrier type trap seal protection device, Spears 2229-015 vertical PVC ball check valve with two male adapters, 1 1/2 inch by 1 1/2 inch PVC adjustable deep seal p-trap, extension to wall and escutcheon. Piping shall connect to vertical waste pipe serving sink.

Miscellaneous: McGuire heavy duty polished chrome-plated cast brass angle valve kits, loose key, flexible risers, escutcheon.

Q. Sink, P-7A:

Fixture: Furnished by Owner. Relocated from existing facility. This plumbing contractor shall include removal, relocating from existing facility and installing at new location. Include capping and plugging of existing piping.

Faucet: Furnished by Owner. Relocated from existing facility. This plumbing contractor shall include removal, relocating from existing facility and installing at new location.

Drain: Furnished by Owner. Relocated from existing facility. This plumbing contractor shall include removal, relocating from existing facility and installing at new location.

Drain and Tailpiece: Elkay LK-99 basket strainer and 1-1/2 inch tailpiece.

Solids Interceptor: Striem solids interceptor HLT-1176-1 seamless, rotationally-molded high density polyethylene with minimum 3/8" uniform wall thickness. Interceptor with removable 304 series stainless steel basket.

Miscellaneous: McGuire heavy duty polished chrome-plated cast brass angle valve kits, loose key, flexible risers, escutcheon.

R. Sink, P-7B:

Fixture: Elkay LR-2022-Q self rimming single compartment 20 inches by 22 inches outside dimension by 7-1/2 inches deep, 18gauge type 302 stainless steel sink with 4 faucet holes 4 inch on center and quick clip system.

Faucet: Elkay LK-2443 hi-arc deck mounted two lever faucet with swing spout with retractable hose and spray.

Drain and Tailpiece: Elkay LK18 perforated grid strainer. Provide 1-1/2 inch tailpiece with dishwasher connection.

Open End Drain: 2 inch PVC open end drain with barrier type trap seal protection device, Spears 2229-015 vertical PVC ball check valve with two male adapters, 1 1/2 inch by 1 1/2 inch PVC adjustable deep seal p-trap, extension to wall and escutcheon. Piping shall connect to vertical waste pipe serving sink.

Dishwashing Machine: Not in Plumbing Contract. Provide necessary waste connection and water connection with individual angle stop and SA-A.

Cleanout: Accessible cleanout fitting same size as the waste pipe shall be installed under bottom of bowl elevation. Cleanout shall be extended as required beyond back of cabinet base or finished wall.

Miscellaneous: McGuire heavy duty polished chrome-plated cast brass angle valve kits, loose key, flexible braided stainless steel risers, dishwasher connection, 1-1/2 inch x 1-1/2 inch polished chrome-plated cast brass adjustable "P" trap, cleanout plug, with PVC adapter extension to wall and escutcheon.

S. Classroom Sink, P-7C:

Fixture: Elkay LRAD-2022-Q self rimming single compartment 20 inches by 22 inches outside dimension by 6-1/2 inches deep, 18 gauge type 302 stainless steel sink with off centered rear drain location, 3 faucet holes 4 inch on center and quick clip system.

Faucet: American Standard Monterrey 7500.170 swivel gooseneck spout with wrist blade handles and 1.5 gpm aerator.

Drain and Tailpiece: Drain: One Elkay No. LKAD18 perforated grid strainer with 1-1/2 inch offset tailpiece.

Cleanout: Accessible cleanout fitting same size as the waste pipe shall be installed under bottom of bowl elevation. Cleanout shall be extended as required beyond back of cabinet base or finished wall.

Insulation: Truebro Handi Lav-Guard antimicrobial white flexible vinyl insulation kit with foam inserts.

Miscellaneous: McGuire heavy duty polished chrome-plated cast brass angle valve kits, loose key, flexible braided stainless steel risers, dishwasher connection, 1-1/2 inch x 1-1/2 inch polished chrome-plated cast brass adjustable "P" trap, cleanout plug, with PVC adapter extension to wall and escutcheon.

T. Clothes Washing Machine, P-8:

Washing Machine: Not in Plumbing Contract.

Washing Machine Connection: Sioux Chief OxBox 696 series outlet with supply and drainage system rough in box with supply connections, outlet connection, secondary drainage knockout, arresters, outlet box for secondary drainage funnel and frame.

U. Refrigerator, P-9:

Refrigerator: Not in Plumbing Contract.

Outlet Box: Sioux Chief 696-G1010MF OxBox 1/4" compression outlet connection outlet box with shutoff valve and arrester.

Provide required 1/4 inch

2.16 WATER HEATERS

A. Tankless gas fired water heater shall be as manufactured by Rinnai.

B. Water supply piping serving thermal expansion absorber and water heaters shall be provided with a shutoff valve and check valve with a 1/8 inch hole drilled in the clapper.

C. Pavilion building domestic condensing water heater shall be Rinnai CU199 wall hung natural gas instantaneous water heater with sealed combustion. The water heater shall have an input rating of 199,000 btu/hour with a domestic water recovery capacity of 3.8 gallons per minute at a 100°F rise.

Water heater temperature shall be set at 140°F.

D. Tankless rack system shall be two (2) Rinnai TRW02CUiN (total four water heaters) pre-assembled wall mounted rack system complete with the following:

1. Two Water heaters installed
2. Common Venting System
3. Gas and water manifolds are properly sized
4. MSB-M electronic control board
5. MSB-C1 cable for connecting water heaters within a banked system
6. Flexible pipe for manifold / water heater connections
7. Drain tees for gas sediment traps
8. Marine grade powdered coated aluminum
9. Threaded pipe ends for maximum flexibility for installations
10. Isolation and Pressure Relief valves included and installed on each water heater

E. Circulation Pump

1. Rinnai Circ-Logic GTK15 system.
 - a. Grundfos 15-55 pump with timer and internal check valve
 - b. 6 foot electrical cord
 - c. 6 foot BX conduit pre-wired to pump
 - d. (5) wire nuts
 - e. Installation manual

F. Warranty

1. Heat Exchanger: 5 years.
 - a. Parts: 5 years.
 - b. Labor: 1 year
 - c. Installation procedure, start up and training session shall be provided by factory trained service technician.

G. Installation

1. Installation shall be in strict accordance with manufacturers installation manual.

- H. Each water heater and or condensate outlet shall be provided with Neutrasafe Condensate Neutralizer condensate neutralizing tube including channel strut base mount, PVC fittings, calcium carbonate, PVC tubing. Outlet tubing shall spill to floor drain.

Neutralizing tube shall be as follows:

<u>Model</u>	<u>CFH Rating</u>
CN2-220	220
CN4-600	600
CN4-1200	1200
CN4-2000	2000

Provide with an initial fill of neutralizing media and two extra bags.

A laminated sign shall be stenciled on or in the immediate area of the condensate neutralizing tube in letters one inch high. The sign shall state the following in exact language:

IMPORTANT

This condensate neutralizing tube must be inspected on a regular and frequent basis and the neutralizing medium or agent replaced when necessary. Failure to do so will result in serious damage to the piping system.

2.17 WATER HEATER SCALE AND CORROSION CONTROL FILTER

- A. Filter shall be Superior Water Conditioners RT-1500 magnetic water treatment filter for control of scale and corrosion.

2.18 THERMAL EXPANSION TANKS

- A. Provide precharged thermal expansion absorbers designed and constructed per ASME Code, Section VIII. Expansion absorbers shall have precharged air chamber, steel outer shell, rigid polypropylene liner, heavy duty butyl diaphragm and stainless steel connection. Expansion tanks smaller than 5 gallons of total volume may be installed in line with supported from overhead. Tanks greater than 5 gallons of total volume shall be floor mounted on a 4 inch housekeeping pad.
- B. Education Facility expansion tank shall be Amtrol ST-12C.
Pavilion expansion tank shall be Amtrol ST-80-V-C.
- C. Pre-charged expansion tank air pressure shall be adjusted to match cold water supply pressure. Failure to follow these instructions could result in damage to the bladder or diaphragm and void all warranties.

2.19 SHOCK ABSORBERS

- A. Maintenance free water hammer arresters shall be furnished and installed at all locations in the water systems where quick acting valves are installed as well as wherever water hammer may occur.
- B. Examples of such locations are as follows:

1. As indicated on the drawings.
 2. Flushometer valves.
 3. Self-closing and metering faucets.
 4. Prior to all pressure reducing valves.
 5. Prior to all in-line solenoid valves.
 6. Dishwashing Machines.
 7. All laundry equipment.
 8. Emergency equipment.
- C. Water hammer arresters shall be as manufactured by Precision Plumbing Products or approved equal. Arresters shall be installed at each and every multiple of fixtures or items as listed above and/or as indicated on drawings. Water hammer arresters may serve groups of fixtures.
- D. Sizing, placement, tested, certified and shall be in accordance with Plumbing and Drainage Institute Standard PDI-WH-201 and the manufacturer's recommendations.
- E. Water hammer arresters shall be as follows:
- | Designation | Fixture Unit Rating | Model |
|-------------|---------------------|----------|
| SA-A | 1-11 | SC-500A |
| SA-B | 12-32 | SC-750B |
| SA-C | 33-60 | SC-1000C |
| SA-D | 61-113 | SC-1250D |
| SA-E | 114-154 | SC-1500E |
| SA-F | 155-330 | SC-2000F |
- F. Water hammer arrestors are maintenance free and do not require an access panel per the manufacturer.
- G. Air chambers will not be approved as an equal.

2.20 PRESSURE GAUGES

- A. Pressure gauge shall be manufactured by Trerice Company, Taylor Instrument or Marshalltown Manufacturing.
- B. Interior water pressure gauge shall be Trerice Company 700 Series with 4 inch diameter face.
1. Interior natural gas shall be by Trerice Company 760B with 4 inch diameter face.
 2. Exterior natural gas shall be by Trerice Company 766SS with 4 inch diameter face.
- C. Pressure gauges shall have brass movement, aluminum case, double strength clear glass window with black embossed figures and graduations on a white dial face, with 1 percent accuracy of scale range.
- D. Gauges shall be furnished with snubbers and needle valve shut off valves.
- E. Gauges shall be furnished with ranges that will locate the intended pressure at the point of application approximately midpoint on the range scale.

2.21 THERMOMETERS

- A. Thermometer shall be as manufactured by Trerice Company, Taylor Instrument or Marshalltown Manufacturing.

- B. Thermometers shall be Trerice Company BX9 adjustable angle design of the separable well type and shall have a 9 inch cast aluminum case. The scale shall be white with black figures and graduations embossed on the scale. The column shall be provided with blue organic fill.
- C. Thermometers shall be furnished with the temperature ranges of Zero to 100 degrees F for cold water and chilled water and of 30 to 240 degrees F for hot water systems.
- D. Thermometers shall be furnished complete with all necessary sockets, wells, connectors and accessories required for installation suitable for the service in which installed. Extension necks shall be furnished for insulated piping.

2.22 TRAP PRIMERS

- A. The trap primer shall be as manufactured by Precision Plumbing Products, Inc., Jay R. Smith Manufacturing Company, Zurn Industries, Inc. or approved equal.
- B. Units shall be Precision Plumbing Products, Inc. automatic brass trap primer units which shall be activated by a drop in water pressure (minimum 3 psi) in the active cold water line in which attached. Units shall meet Code and ASSE Standard #1018. Units shall be adjustable to line pressure and desired delivery amount.
- C. Trap primers and distribution units shall be in accordance with the following:

Drains	Model	Distribution Unit
1	PR-500	NA
2	PR-500	DU-2
3	PR-500	DU-3
4	PR-500	DU-4
5	PO-500	DU-2 and DU-3
6	PO-500	Two DU-3
7	PO-500	DU-3 and DU-4
8	PO-500	Two DU-4

2.23 SOLIDS INTERCEPTOR

- A. Solids interceptor shall be Striem Aardvark AA-4 with 4" plain end inlet/outlets, maximum flow rate of 75 GPM, teleglide risers and with lifetime guarantee and made in the USA. Tank material shall be polyethylene. Interceptor shall have removable, corrosion-resistant filter basket. Interceptor shall be equipped with high and low outlet options, with a movable sewer gas trap to be located on either outlet. Interceptor shall be furnished for below grade installation. Cover shall be water and gas tight with a minimum 2,000 lbs load capacity.

2.24 ELEVATOR SUMP PUMPS

- A. Elevator pit sump pump shall be Stancor OM50-AOPP/120 effluent pump with oil sensor, float switch, control panel with alarm, 2" discharge, rated 3/4 hp, 120 v, 60 HZ, 3450 rpm, capacities of 50 GPM at 25' TDH , 50 feet cables et and high water level alarm.

2.25 PIPE IDENTIFICATION AND VALVE TAGS

- A. All piping, except that piping which is within inaccessible chases, shall be identified with semi-rigid plastic identification markers equal to Seton Setmark pipe markers. Direction of flow arrows are to be included on each marker. Each marker background shall be appropriately color coded with a clearly printed legend to identify the contents of the pipe in conformance with the "Scheme for the Identification of Piping Systems" (ANSI/ASME A13.1-2007). Setmark snap-around markers shall be used for overall diameters up to six inches and strap-around markers shall be used above six inch overall diameters. Markers shall be located adjacent to each valve, at each branch, at each cap for future, at each riser take off, at each pipe passage through wall, at each pipe passage through floors, at each pipe passage to underground and on vertical and horizontal piping at 20 foot intervals maximum.

- B. All valves shall be designated by distinguishing numbers and letters carefully coordinated with a valve chart. Valve tags shall be 19 gauge polished brass, 1-1/2 inch diameter with stamped black filled letters similar to Seton S type 250-BL or approved equal. Lettering shall be 1/4 inch high for type service and 1/2 inch for valve number. Tag shall be attached to valves with approved brass "S" hooks, or brass jack chain. Whenever a valve is above a hung ceiling, the valve tag shall be located immediately above the hung ceiling.
- C. Furnish a minimum of two typed valve lists to be framed under glass or Plexiglass. Each chart shall be enclosed in an approved .015 inch thick plastic closure for permanent protection. Valve numbers shall correspond to those indicated on the Record Drawings and on the printed valve lists. The printed list shall include the valve number, location and purpose of each valve. It shall state other necessary information such as the required opening or closing of another valve when one valve is to be opened or closed. Printed framed valve lists shall be displayed in each Mechanical Room or in a location designated by the Owner.
- D. Equipment nameplates shall be 3/4 inch by 2-1/2 inch long .02 inch aluminum with a black enamel background with engraved natural aluminum letters similar to Seton Style 2065-20. Nameplate shall have pressure sensitive taped backing.
- E. All interior and exterior underground piping and utilities shall have metalized warning tape installed above the pipe or line that identifies the specific system buried below. Tape shall consist of a minimum 3.5 mil solid foil core encased in a protective plastic jacket (total thickness 5.5 mils) and be 6" wide with black lettering imprinted on a color coded background that conforms to APWA color code specifications. Tape shall be installed from 18" to 30" above the pipe and in no case less than 6" below grade.
- F. All interior and exterior underground non-metallic piping and utilities shall have a tracer wire installed along the length of the pipe. Tracer wire shall be 14 gauge minimum, copper single-conductor wire with insulation and shall be continuous along the pipeline passing through the inside of each valve box.

2.26 DISINFECTION OF WATER SYSTEMS

- A. All water systems shall be disinfected in accordance with Local Public Health and Plumbing Code Requirements.

2.27 TESTS AND APPROVALS

- A. Pipe lines shall be blown or flushed clean, before piping tests are applied. All plumbing work shall be tested as herein specified. No portion shall be covered, concealed, used or made inaccessible to testing, inspection, repair, correction or replacement until tests thereof have been satisfactorily completed in the presence of the Architect's Authorized Representatives. The Plumbing Subcontractor must accommodate his testing operations to the progress of the project as a whole. Correct all defects appearing under test and repeat the tests until all parts of the work have withstood them successfully.
- B. Furnish all labor, material and services for testing, including testing plugs, pumps and compressors; he shall make and remove all temporary piping connections required for the tests and shall dispose of test water and all wastes after tests. Leave all work in good order, ready for full use.
- C. Tests on all plumbing systems shall be made in accordance with the requirements of the Local Plumbing Code and the codes, standards, recommended practices and manuals of the National Fire Protection Association.

PART 3 - EXECUTION

3.1 WORKMANSHIP

- A. Prior to the work of this section, this Contractor must ascertain that preceding work has been accomplished in a manner to permit compliance with the level of quality required by this Section.

- B. The entire work provided in this specification shall be constructed and finished in every respect in a workmanlike and substantial manner. It is not intended that the drawings shall show every pipe, fitting, and appliance. Furnish all parts as may be necessary to complete the system in accordance with the best trade practices and to be the satisfaction of the Architect, Engineer and General Contractor.
- C. This Contractor shall keep other contractors fully informed as the shape, size and position of all openings required for his apparatus and shall give full information to the General Contractor or other contractors sufficiently in advance of the work so that all openings may be built in advance. Furnish and install all sleeves, supports, etc., specified or required.
- D. In the case of failure on the part of this Subcontractor to give proper and timely information as noted above, he shall do his own cutting and patching, or have same done by the General Contractor at this subcontractor's expense, but in any case, without extra expense to the Owner and General Contractor.
- E. This Contractor shall obtain detailed information from the manufacturer of apparatus as to the proper method of installing and connecting same. He shall also obtain all information from the General Contractor and the other contractors which may be necessary to facilitate his work and the completion of the whole project.

3.2 CORE DRILLING

- A. Where a core hole or opening occur larger than 10 inches in any dimension is required, or where dimension between two openings in less than two times maximum dimension of largest opening, and condition is not shown on architectural or structural drawings, obtain prior written approval of the Owner.
- B. At floor slabs and walls where a core hole is to be drilled or opening is to be cut, contractor shall find and mark all reinforcing in both faces located by means of x-ray, pach-ometer, or prof-ometer. Submit sketch indicating core holes, openings, location of rebar, piping, conduit or any other obstruction for review.
- C. All holes through concrete or masonry for the passage of plumbing piping not provided by sleeves or openings at the time of casting, shall be cut by the Plumbing Contractor using an approved core boring machine with diamond edge bit and vacuum sludge removal device. The size of holes shall provide for fire stopping around a pipe. The location of all core drilled holes shall be coordinated with the structural reinforcing and be reviewed by the Architect prior to commencing work.
- D. Prior to coring, the Plumbing Contractor shall submit a minimum 1/8 in. scale plan, dimensioning the location of proposed cored opening locations and indicating the core diameter. Prior to developing the coring plan, the Plumbing Contractor shall examine the site carefully in an attempt to determine whether there are structural, mechanical or electrical obstacles in the proposed coring locations. Once the plans are reviewed by the Architect and Owner's representative, the Plumbing Contractor may proceed with caution. If an electrical conduit, for example, was hit during coring operations, and it was determined that the Plumbing Contractor was negligent by not noting a conduit turning into the slab below, he would be responsible for the repair cost. If the Contractor were not found to be negligent, then the Owner would assume the cost of the repair.

3.3 TESTING PIPING SYSTEMS

- A. Test all work in the presence of the Architect/Engineer and/or Owner, Owner's representative and Plumbing Inspector as called for in local codes.
- B. After soil, waste and vent piping is in place and before being furred in, plug lower ends and fill. The system shall be left tight under these conditions and water level shall be maintained intact for a period of at least four hours.
- C. Test domestic water piping and service by applying a hydrostatic pressure of 125 psi using a pump for this purpose. Make sure that all lines are properly plugged or capped, and that air

has been vented before applying pressure, which shall remain constant without pumping for one hour at least.

- D. Gas system piping shall be tested at a pressure of 50 psig and pressure shall be held for two hours minimum.
- E. This Contractor shall furnish all equipment, labor and materials, required for these tests.
- F. Any leaks in joints or evidence of defective pipe or fittings disclosed by tests shall be immediately corrected by replacing defective parts with new joints or corrected materials. No makeshift repairs effected by caulking threaded pipe with lead wool, application of wicking or patented compounds being permitted. Perform smoke tests as required by local code or by the Architect/Engineer.

3.4 PROTECTION AND CLEANING

- A. Each subcontractor shall be responsible for his work and equipment until finally inspected, tested and accepted. Carefully store materials and equipment, which are not immediately installed after delivery on site. Close open ends or work with temporary covers or plug during construction to prevent entry of obstructing materials.
- B. Each subcontractor shall protect work and materials of other trades from damage that might be caused by his work or workman and make good damage thus caused.
- C. The premises shall be kept reasonably clean at all times, and rubbish shall be removed as directed by the General Contractor.
- D. Upon completion of this work, the Contractor shall clean all fixtures and equipment and replace damaged parts. Upon failure of this Contractor to fulfill his obligation, this work will be taken care of at his expense.

3.5 WORK COORDINATION AND JOB COORDINATION

- A. Plumbing equipment shall not be installed in congested and possible problem areas without first coordinating the installation of same with the other trades and the General Contractor.
- B. Particular attention shall be directed to the coordination of system with all equipment of other trades installed in and above the ceiling areas. Conflicts in heights and clearance above hung ceilings shall be brought to the attention of the General Contractor for a decision before equipment is installed.
- C. Furnish to the General Contractor and other trades all information relative to the position of the plumbing installation that will affect them so that they may plan their work and installation accordingly.

3.6 SUPPLEMENTARY STEEL, CHANNEL AND SUPPORTS

- A. Furnish and install all supplementary steel, channels and supports required for the proper installation, mounting and support of all equipment.
- B. Supplementary steel and channels shall be firmly connected to building construction in a manner approved by the Architect/Engineer.
- C. The type and size of the supporting channels and supplementary steel shall be determined by the Plumbing Subcontractor and shall be sufficient strength and size to allow only a minimum deflection in conformance with the manufacturer's requirements for loading.
- D. All supplementary steel and channels shall be installed in a neat and workmanlike manner parallel to the walls, floor and ceiling construction. all turns to be made with 90 degree fittings, as required to suit the construction and installation conditions.

3.7 SLEEVES AND INSERTS

- A. Sleeves shall be furnished, set and properly secured in place and at all points where piping passes through masonry or concrete. All sleeves shall be of sufficient diameter to provide 1/4-in. clearance around the pipe.

- B. Sleeves through concrete slabs, and interior concrete and masonry walls or partitions shall be steel pipe. Fire stop annular openings between sleeves and pipes at floor slab passages and make watertight. Galvanized sleeves and copper piping shall not be placed in concrete.
- C. Install UL listed and FM approved inserts or other anchoring devices in concrete and masonry construction as required to support piping. Inserts shall be of the adjustable type as manufactured by Carpenter and Patterson, Grinnell, or Fee and Mason.

3.8 SYSTEM IDENTIFICATION

- A. All valves on pipes of every description shall have circular brass valve tags of at least 1-1/2 in. in diameter, attached with brass hooks to each valve stem. Stamp number of the valve and the service, such as "HW", "CW", "GAS", etc., for hot water, cold water, gas, etc., respectively. The numbers of each service shall be consecutive and shall correspond with the numbers indicated for valves and controls on the record drawings and on three printed valve lists. These printed lists shall state number and locations of each valve and control and the section, fixture or equipment which it controls.
- B. The printed valve lists shall be prepared in a form to meet the approval of the Architect and Engineer and one copy shall be framed under glass and mounted in approved locations.
- C. All plumbing lines and equipment shall be identified by pipe markings, which shall be provided by this Contractor. Markers shall be applied every 20 ft. Markings shall indicate pipe content and direction of flow. The markers shall be as manufactured by Seton Name Plate Corp. or equal.

3.9 SAFETY PRECAUTIONS

- A. Furnish, place and maintain proper guards for the prevention of accidents and any other necessary construction required to secure safety of life and property.

3.10 INSERTS AND OPENINGS

- A. Inserts: Install inserts or other anchoring devices in concrete and masonry construction as required to support piping. Inserts shall be of the adjustable type as manufactured by Carpenter and Patterson, Grinnell or Fee and Mason.
- B. Escutcheons: All exposed pipe, uncovered, passing through walls, floors or ceilings shall be fitted with one piece chrome plated brass escutcheons with set screw holding in position. Floor escutcheons to be deep enough to fit over sleeves, fastened to pipe and extending down to floor.

3.11 PLANS AND SPECIFICATIONS

- A. The drawing showing layout of the plumbing systems indicate the approximate location of outlets, apparatus and equipment are schematic. The final determination as to the routing shall be governed by structural conditions and other obstructions.
- B. The right to make any reasonable change in the location of outlets, apparatus and equipment up to the time of the roughing-in is reserved by the Architect and Engineer without involving any expense to the Owner or the General Contractor.
- C. The specifications supplement the drawings and provide specifics pertaining to the methods of material to be used in the execution of the work.

3.12 SANITARY WASTE, STORM WATER AND VENT SYSTEMS

- A. Install cast-iron soil piping according to Cast Iron Soil Pipe and Fittings Handbook (CISPI) Chapter IV, "Installation of Cast Iron Soil Pipe and Fittings."
- B. Furnish and install piping to take wastes from all soil and waste stacks, fixtures, drains and equipment as indicated and/or described in these plans and specifications.

- C. Unless specifically noted otherwise on the plans, all horizontal piping 4 in. and larger shall be pitched at the rate of 1/8 in. per foot in the direction of the flow. Horizontal piping 3 in. and smaller shall be pitched at the rate of 1/4 in. per foot in the direction of the flow.
- D. Vent System: Furnish and install piping to vent all stacks, fixtures, traps and appliances as indicated on the drawings and/or required to meet the Plumbing Code. All vent piping shall be concealed where possible with the horizontal pipe pitching back toward fixtures to allow connection to drain. Whether indicated on plan, riser diagram or not, offset vents below the roof to avoid air intakes, equipment, penthouse mansard etc., bring vents through the roof a minimum of 10 feet away from air intakes, windows, and operable sash and 10 ft. away from other obstructions.

3.13 HOT AND COLD WATER SYSTEMS

- A. Furnish and install complete cold, hot and hot water return systems to service all fixtures and equipment indicated on the drawings or specified as requiring cold or hot water. Cold water piping shall start at the connection to the water main indicated on plan and extend to all fixtures and equipment, including piping, fittings and valves requiring connections. Hot water piping shall extend from the hot water heater to all fixtures and equipment, including piping, fittings and valves. In general, piping shall pitch upward in the direction of flow with each branch and riser separately valved and with 1/2 in. hose end drains on the outlet side of the valve and at all low points in the systems. Install valves for each battery of fixtures and other valves as necessary to isolate all parts of these systems. All valves shall be accessible.
- B. Hot water piping shall be circulated as shown on plans to ensure uniform temperatures throughout the system. All branches larger than 50 ft. shall be provided with hot water return lines.

3.14 NATURAL GAS SYSTEM

- A. Furnish and install pipe, fittings, valves and connections to all gas-fired equipment and all accessories and incidentals as indicated or specified to maintain a complete gas system. Install solenoid valves supplied by others as required. Installations shall be made in accordance with the State Gas Code requirements. All horizontal gas piping shall be pitched not less than 1/4 in. in 15 ft. to prevent traps. Pitch piping to risers. Install an 8 in. long sediment leg at the base of all risers.
- B. All changes in direction shall be made with plugged tees for cleaning out piping. All horizontal branch outlet pipes shall be taken from the top or side of horizontal mains and not from the bottom. Coordinate the installation of the gas system with the utility company and General Contractor.
- C. Provide gas train vents to the atmosphere for all gas-fired equipment as required by Code.

3.15 INSULATION

- A. Ensure that all pipe and fitting surfaces over which insulation is to be installed are clean and dry.
- B. Ensure that insulation is clean, dry, and in good mechanical condition with all factory-applied vapor or weather barriers intact and undamaged. Wet, dirty, or damaged insulation shall not be acceptable for installation.
- C. Ensure that pressure testing of piping and fittings has been completed prior to installing insulation.
- D. General
 1. Install all insulation materials and accessories in accordance with manufacturer's published instructions and recognized industry practices to ensure that it will serve its intended purpose.
 2. Install insulation on piping subsequent to installation of heat tracing, painting, and acceptance tests.

3. Install insulation materials with smooth and even surfaces. Insulate each continuous run of piping with full-length units of insulation, with single cut piece to complete run. Do not use cut pieces or scraps abutting each other. Butt insulation joints firmly to ensure complete, tight fit over all piping surfaces.
 4. Maintain the integrity of factory-applied vapor barrier jacketing on all pipe insulation, protecting it against puncture, tears or other damage. All staples used on cold pipe insulation shall be coated with suitable sealant to maintain vapor barrier integrity.
- A. Fittings
1. Cover valves, fittings, and similar items in each piping system using one of the following:
 2. Mitered sections of insulation equivalent in thickness and composition to that installed on straight pipe runs.
 3. Insulation cement equal in thickness to the adjoining insulation.
 4. Owens Corning PVC Fitting Covers insulated with material equal in thickness and composition to adjoining insulation.
- B. Penetrations
1. Extend piping insulation without interruption through walls, floors, and similar piping penetrations, except where otherwise specified.
- C. Joints
1. Butt pipe insulation against hanger inserts. For hot pipes, it is recommended all joints be staggered when operating temperature is over 400F (204C) double layer. Seal jacketing according to type being used. For cold piping, seal self-sealing laps by firmly rubbing down surface of tape and flap.
 2. All pipe insulation ends shall be tapered and sealed, regardless of service.
- D. Vertical Piping
1. If specified on contract drawings, all insulated, exposed vertical piping within the building and all insulated piping exposed to the outdoors shall be additionally jacketed with 0.016" thick (0.4 mm) (minimum) aluminum. Vertical piping shall be protected to a height of 8'-0" (2.4 m) above the floor.
- E. Field Quality Assurance
1. Upon completion of all insulation work covered by this specification, visually inspect the work and verify that it has been correctly installed. This may be done while work is in progress, to assure compliance with requirements herein to cover and protect insulation materials during installation.
- F. Protection
1. Replace damaged insulation, which cannot be satisfactorily repaired, including insulation with vapor barrier damage and moisture-saturated insulation.
 2. The insulation contractor shall advise the general and/or the mechanical contractor as to requirements for protection of the insulation work during the remainder of the construction period, to avoid damage and deterioration of the finished insulation work.
- G. Safety Precautions
1. Insulation contractor's employees shall be properly protected during installation of all insulation. Protection shall include proper attire when handling and applying insulation materials, and shall include (but not be limited to) disposable dust respirators, gloves, hard hats, and eye protection.

2. The insulation contractor shall conduct all job site operations in compliance with applicable provisions of the Occupational Safety and Health Act, as well as with all state and/or local safety and health codes and regulations that may apply to the work.

3.16 CHLORINATION

- A. Each water piping system (cold water, hot water, hot water circulation, non potable cold water, non potable hot water, non potable hot water circulation and tepid water) shall be cleaned and disinfected by this Contractor. Cleaning and disinfection shall be performed after all pipes, valves, fixtures and other components of the systems are installed, tested and ready for operation.
- B. All water piping systems shall be thoroughly flushed with clean potable water prior to disinfection to remove dirt and other contaminants.
- C. Disinfection shall be done using sodium hypochlorite in the following manner:
 1. A service cock shall be provided and located at the water service entrance. The disinfecting agent shall be injected into and through the system from this cock only.
 2. The disinfecting agent shall be injected by a proportioning pump or device through the service cock slowly and continuously at an even rate. During disinfection, flow of disinfecting agent into main water supply is not permitted.
 3. All sectional valves shall be opened during disinfection. All outlets shall be fully opened during injection and the residual checked with orthotolidin solution.
 4. When the chlorine residual concentration, calculated on the volume of water the piping will contain indicated not less than 50 ppm (parts per million) at all outlets, then all valves shall be closed and secured.
 5. The residual chlorine shall be retained in the piping systems for a period of not less than 24 hours.
 6. After the retention, the residual shall be not less than five parts per million. If less, then the process shall be repeated as described above.
 7. If satisfactory, then all fixtures shall be flushed with clean potable water until residual chlorine by orthotolidin tests shall be not greater than the incoming water supply.
- D. All work and certification of performance shall be performed by approved applicators or qualified personnel with chemical and laboratory experience. Certification of performance shall indicate:
 1. Name and location of the job and date when disinfection was performed.
 2. Material used for disinfection.
 3. Retention period of disinfectant in piping system.
 4. ppm chlorine during retention.
 5. ppm chlorine after flushing.
 6. Statement that disinfection was performed as specified.
 7. Signature and address of company or person performing disinfection.
- E. Upon completion of final flushing (after retention period) the plumbing subcontractor shall obtain a minimum of one water sample from each water piping system and submit samples to a State approved laboratory. Samples shall be taken from faucets located at highest floor and furthest from meter or main water supply. The laboratory report shall show the following:
 1. Name and address of approved laboratory testing the samples.x
 2. Name and location of job and date the samples were obtained.

3. The coliform organism count. (An acceptable test shall show the absence of coliform organisms.)
- F. If analysis does not satisfy the above minimum requirements, the disinfection procedure shall be repeated.
- G. Before acceptance of the systems, this Contractor shall submit to the Project Manager and Clerk of Works for his review, three (3) copies of Certification of Performance as specified above.
- H. Under no circumstances shall this contractor permit the use of any portion of domestic water systems until properly disinfected, flushed and certified.

3.17 KITCHEN EQUIPMENT

- A. Provide roughing and final connections for water, waste, vent and gas systems; including traps, tailpiece and strainers, wheel handle stops, valves, cocks and appurtenances to fixtures and equipment requiring same. Each fixture and piece of equipment, including work in, under or through tables, cabinets and equipment chases, shall be valved and trapped.
- B. As equipment purchased may vary from that indicated on this plan, and, therefore, require some re-arrangements of equipment different from that indicated on the drawings, make connections to such re-arranged equipment without additional cost to Owner. Unpack, assemble and install supply trim for equipment and fixtures furnished by Owner.
- C. Provide miscellaneous equipment connections and indirect drains from service units and similar equipment. Unions shall be installed at kitchen/bar equipment and at other such places as may be necessary to disconnect piping so as to make repairs.
- D. Roughing shall not be undertaken until Architect has approved equipment and fixture shop drawings and kitchen/bar template is furnished by pertinent manufacturer so that connecting requirements may be verified and work installed in a neat and workmanlike manner. Exact location of service connections shall be obtained prior to roughing.
- E. Shock absorbers shall be installed in conjunction with quick closing valves including dishwasher and booster heater. Shut off valve shall be installed beneath each absorber. Absorber shall be sized in accordance with Plumbing and Drainage Institute standard PDI-WH 201.
- F. Provide 1/2 in. stop valves on all fixtures and equipment supplies. Vacuum breaker shall be installed in conjunction with water lines to booster, garbage disposal and dishwasher and where required to prevent polluted back-siphonage.
- G. Where an automatic fire-extinguishing system is provided for the protection of commercial type cooking equipment (i.e. fryers, griddles, range tops, grills, etc.) solenoid valves shall be furnished and installed by this contractor to automatically shutdown the fuel supply to the cooking equipment.
- H. Refer to Kitchen Food Service Equipment plans for a complete understanding of plumbing requirements & service schedules and include all such costs in bid amount.

3.18 WATER SERVICE

- A. Furnish and install a complete water service piping system to **ten** feet outside the building foundation including piping, fittings and supports, valves, and connection to the water main as shown on the drawings and specified herein.
- B. All materials and installation shall be in complete accord with the requirements of the local water department and NFPA Pamphlet. Pay all inspection fees. Include in bid.
- C. Backfilling of trench excavation will not be permitted until after the domestic water service line has been installed, inspected, tested and accepted. With prior written approval of the Architect, partial backfill may be installed, leaving joints exposed.

- D. When a section of pipe is ready for testing, the line shall be completely filled with water, thoroughly cleaned for elimination of all air, and a leakage test made.
- E. Testing shall be carried out in an approved manner and shall consist of filling the main with water from the municipal distribution system and maintaining a hydrostatic test pressure of 200 per NFPA 24 Standards. All visible leaks shall be made tight in an approved manner. Any defective pipe, fitting or material shall be removed and replaced at the expense of the Contractor and the test shall be repeated until the conditions of allowable leakage are met. Thoroughly flush the service per NFPA 24 Standards.
- F. Disinfection shall be performed in an approved manner in conforming with AWWA "Procedure for Disinfecting Water Mains" designation C601-48 and shall be witnessed by the Architect or his authorized agent. Before disinfection, the line shall be flushed with water to create as high a velocity as practicable.
- G. Following chlorination and after the entire length of the line is ready for operation, all treated water shall be flushed thoroughly from the newly laid pipe line, at its extremities, until the replacement water throughout its length will upon test, both chemical and bacteriological, be provided equal to the quality introduced at the permanent source of supply. Where bends turn down and the resulting thrust will be upward, provision to restrain the thrust shall be made with joint harnesses or thrust blocks. Submit proposed methods to Architect for approval.

END OF SECTION

THIS PAGE INTENTIONALLY LEFT BLANK

SECTION 230000

MECHANICAL

PART 1: GENERAL

1.1 RELATED DOCUMENTS

- A. Drawings and General Provisions of Contract, including General and Supplementary Conditions and Division-1 Specification Sections, apply to work of this section.

1.2 SUMMARY OF WORK

- A. Provide complete functional Heating, Ventilating and Air Conditioning system as shown on Mechanical Construction Documents.

1.3 REFERENCE STANDARDS

- A. NFPA Standards
- B. ANSI Standards
- C. ASME Standards
- D. ASTM Standards
- E. AWWA Standards
- F. ASHRAE Standards
- G. SMACNA Standards
- H. OSHA Standards
- I. NEBB Standards
- J. Local Codes and Ordinances
- K. Owner's Insurance Company Requirements
- L. Where the contract documents indicate more stringent requirements than the above codes and ordinances, the contract documents shall take precedence.
- M. File all documents, pay all fees and secure all permits, inspections and approvals necessary for the work of this section.

1.4 CONTRACT DRAWINGS & SPECIFICATIONS

- A. The Contract Drawings are generally diagrammatic and convey the Scope of Work and General Arrangement of apparatus and equipment. The locations of all items shown on the drawings or called for in the specifications that are not definitely fixed by dimensions are approximate only. The exact locations necessary to secure the best conditions and results must be determined at the project and shall have the approval of the Architect and Engineer before being installed. The Subcontractor shall follow drawings in laying out work and shall check drawings of the other trades to verify spaces in which work will be installed. Maintain maximum headroom and space conditions at all points. If directed by the General Contractor, Engineer and/or Architect, the Subcontractor shall, without extra charge, make reasonable modifications in the layout as needed to prevent conflict with work of other trades or before proper execution of the work.
- B. Specifications: The specifications are intended only to complement the drawings; however,

work detailed and/or noted only on the drawings or work described only in the specifications shall all be considered as part of the scope of work.

1.5 CONFLICT BETWEEN PLANS AND SPECIFICATIONS

- A. In case of conflict between the contract drawings and specifications, the Engineer shall determine which takes precedence.

1.6 SHOP DRAWINGS AND PRODUCT DATA

- A. SUBMITTALS: Submit shop drawings, manufacturers data and certificates for equipment, materials and finish, and pertinent details for each system where specified in each individual section, and have them approved before procurement, fabrication, or delivery of the items to the job site. Partial submittals will not be acceptable and will be returned without review. Submittals shall include the manufacturer's name, trade name, catalog model or number, nameplate data, size, layout dimensions, capacity, project specification and paragraph reference, applicable industry, and technical society publication references, and other information necessary to establish contract compliance of each item the Contractor propose to furnish.
- B. Submit in accordance with Division 1.
- C. It is the intent of these specifications that all equipment, materials and workmanship used on this project be in complete conformance with all local, state and national codes, ordinances and standards.
- D. Substitutions shall be equivalent to specified equipment in all aspects of quality and performance and shall conform to the intent stated above. It is the contractor's responsibility to submit only those items that meet these requirements. Should any non-conforming items be installed, they shall be replaced by the contractor at no additional cost to the owner.
- E. The approval of the equipment does not relieve the Subcontractor of responsibility of shop drawing errors related to details, sizes, quantities, wiring diagram arrangements and dimensions which deviate from the Specifications, and/or job conditions as they exist.
- F. Refer to General Requirements for the substitutions of equipment and submittal of shop drawings. If apparatus or materials are substituted for those specified, and such substitution necessitates changes in, or additional connections, piping, supports, or construction, it shall be provided. Contractor to assume cost and entire responsibility thereof.

1.7 INSPECTION AND TESTS

- A. During the progress of the work it shall be subject to the inspection of the Owner and to such other inspectors, as may have jurisdiction.
- B. At completion of the work, Contractor shall submit to the Owner's representative in writing a statement stating: (1) that the work is complete; (2) that the entire installation is in accordance with the specification; (3) that preliminary tests have been made; and (4) that the work is ready for final inspection and test.
- C. A final inspection of the installation to determine compliance with the drawing and specifications will be made by the Owner's representative. Work will be checked for quality of materials, quality of workmanship, proper installation and finished appearance. This Contractor shall provide the services of the project foreman for inspection purposes. The foreman shall remove and reinstall access panels, ceiling tiles, etc., as required to facilitate any inspections required by the Owner's representative.
- D. The Contractor shall arrange and conduct operating tests on all equipment in the presence of the Owner's representative. The component parts of systems and the various systems shall be demonstrated to operate in accordance with the requirements and intent of this specification. Any non-complying or defective materials or workmanship disclosed as a result

of the inspection and the Contractor shall correct tests promptly, and the tests repeated as often as necessary until approved and accepted by the Owner's representative.

1.8 ELECTRICAL EQUIPMENT

- A. Electrical components of mechanical equipment and systems, such as motors, factory mounted motor starters, disconnects, and control equipment shall be provided under the related Section of Division 23.
- B. Temperature control equipment, including thermostats, zone valves, relays, aquastats, etc. shall be provided under related sections of Division 23. Temperature control wiring not specifically shown on electrical drawings shall be provided under related Section of Division 23.
- C. Upon completion of temperature control system wiring, the responsibility of the control system will fall under Division 23.
- D. All electrical equipment installed in concealed spaces shall be provided with a hard-wired electrical connection. Plug-type disconnects shall not be allowed in concealed spaces. Equipment provided with plug-in cords shall not have their cords modified.

1.9 OPENINGS IN EXTERIOR WALLS OR ROOF

- A. Openings in exterior walls or roof shall be kept properly plugged and caulked at all times, except when being worked on to preclude the possibility of flooding due to storm or other causes. After completion of work, openings shall be permanently sealed and caulked in a manner approved by the Architect.

1.10 GUARANTEE

- A. Except as otherwise specified, all work, materials and equipment shall be guaranteed against defects resulting from the use of inferior materials, equipment, or workmanship for one year from the date of final completion of the contract, or from full acceptance by the Owner, whichever is earlier.
- B. If, within any guarantee period, repairs or changes to guaranteed work are required as a result of the use of defective materials or equipment, inferior workmanship or work that is not in accordance with the terms of the contract, and upon receipt of notice from the Owner, the following shall be done without expense to the Owner.
- C. Place in satisfactory condition in every particular all of such guaranteed work and correct all defects therein.
- D. Repair all damage to the building or site/equipment or contents thereof which is the result of the use of defective materials or equipment or inferior workmanship, or of work not in accordance with the terms of the contract.
- E. Make good any work or materials, or the equipment and contents of said building or site disturbed in fulfilling any such guarantee.
- F. In fulfilling the requirements of the contract or of any guarantee embraced in or required thereby, any work guaranteed under another contract is disturbed, restore such disturbed work to original condition and guarantee such restored work to the same extent as it was guaranteed under such other contract.
- G. If upon failure to proceed promptly after notice to comply with the terms of the guarantee, the Owner may have the defects corrected and Contractor and his surety shall be liable for all expenses incurred.
- H. This Contractor shall obtain in the General Contractor's and Owner's name, the standard written manufacturer's guarantee of all materials furnished under this Section where such guarantees are offered in the manufacturer's published product data. All these guarantees

shall be in addition to, and not in lieu of, other liabilities, which the Contractor may have by law or other provisions of the Contract Documents. The guarantee shall be for a period of one (1) year minimum from the date of acceptance or final payment.

1.11 CLEANING OF SYSTEM

- A. Thoroughly clean piping, ducts, fixtures and equipment of all foreign substances inside and out before placing in operation. All air handling equipment shall be provided with "construction filters" for use during construction. Once construction is substantially complete and prior to final testing adjusting and balancing, furnish and install new filters for each piece of equipment.
- B. If any foreign matter should stop any part of a system after being placed in operation, clean and reconnect system.
- C. Remove all covers of interior floor drains and cleanouts, clean of all dirt, concrete traces, etc., then lightly grease and reinstall.
- D. Existing HVAC systems which are being tied into or otherwise modified shall be thoroughly cleaned and refurbished prior to being placed back in service.
 - 1. Duct Systems shall be cleaned of all foreign contaminants, dust and debris.
 - 2. Hydronic Systems shall be fully flushed, cleaned, refilled and treated.
 - a) Contractor shall test existing system fluid to determine the concentration of freeze-inhibitor in the system prior to drain down.
 - b) Refilling of the system shall include freeze inhibitor matching the concentration of the system prior to drain-down.
 - 3. During contractor shall bring to the attention of the owner and engineer any perceived deficiencies in existing systems including but not limited to:
 - a) Code deficiencies
 - b) Inoperable equipment
 - c) Leaking ductwork and/or piping
 - d) Missing or deteriorating insulation
 - e) Excessive noise

1.12 TEMPORARY OPENINGS

- A. Coordinate construction and provide temporary openings in the building as required for the admission of equipment furnished under this Division.

1.13 DEFINITIONS

- A. "Piping" includes, in addition to pipe, all fittings, valves, hangers, and other accessories relating to such piping.
- B. "Concealed" means hidden from sight in trenches, chases, furred spaces, shafts, hung ceilings, embedded in construction or in crawl spaces.
- C. "Exposed" means not installed underground or "concealed" as defined above.
- D. "Provide" means furnish and install complete and ready to operate.

1.14 EQUIPMENT DEVIATIONS

- A. Where proposals to use an item of equipment other than that specified which requires any redesign of the structure, partitions, foundations, piping, wiring or any other part of the

mechanical, electrical or architectural layout, all such redesign, and all new drawings and detailing required therefore, shall be prepared by the Architect at the Contractor's expense.

- B. Where such approved deviation requires a different quantity and arrangement of ductwork, piping, wiring, conduit, and equipment from that specified or indicated on the drawings, furnish and install any such ductwork, piping, structural supports, insulation, controllers, motors, starters, electrical wiring and conduit, and any other additional equipment required by the system, at no additional cost to the Owner.

1.15 EQUIPMENT PADS

- A. All grade and floor mounted equipment shall be provided with a reinforced concrete pad. Refer to architectural plans for pad locations, thickness, sizes, and construction requirements.
- B. If grade and/or floor mounted equipment is shown but no pad indicated on the architectural plans the contractor shall be responsible for clarifying the necessity, size, and location of any pads during the bidding process. No additional compensation will be given for pads which are required by this section but not indicated on the plans if no formal request for clarification was issued during the bidding process.

1.16 EQUIPMENT VISIBILITY

- A. Where equipment is located on the roof or outside the building at grade in a place that is visible to the owner or general public, the following shall take place prior to roofing, placement of roof curbs or concrete equipment pads, routing of piping/electrical/controls/etc.:
 - 1. The contractor shall construct a full-size temporary mock-up of the equipment in the proposed location.
 - 2. The contractor shall review mock-up with architect and owner to obtain approval of equipment location. After approval, contractor shall remove and dispose of mockup materials.
 - 3. Any modification to equipment location to satisfy architect/owner requirements shall be noted on a shop drawing and submitted to the architect/engineer for comment and approval prior to final placement of equipment.

1.17 ELECTRICAL ROOM REQUIREMENTS

- A. Do not install any piping, ductwork or equipment in or through electrical rooms, transformer rooms, electrical closets, telephone rooms or elevator machine rooms, unless piping or ductwork of equipment is intended to serve these rooms. Additionally, no ductwork or piping will be installed above electric panels. If the Contractor violates this requirement, he shall remove and/or relocate all items as required at his expense and to the satisfaction of the Architect.

1.18 COOPERATION WITH OTHER TRADES

- A. Give full cooperation to other trades and furnish in writing to the Architect any information necessary to permit the work of all trades to be installed satisfactorily and with the least possible interference or delay.
- B. Coordination drawings shall be initiated by this contractor. It this contractor's responsibility for preparation of project coordination drawings showing the installation of all equipment, piping, ducts and accessories to be provided under Section 230000 of the Specifications.
 - 1. Drawings shall be prepared at not less than 1/4 in. = 1 ft. scale, and shall show building room layouts, structural elements, ductwork and lighting layouts of function. Drawings shall indicate horizontal and vertical dimensions, to avoid interference with structural framing, ceilings, partitions, and other services.

2. A reproducible copy of each drawing prepared shall then be submitted to each Contractor working under Sections 210000, 220000, and 260000, who shall be responsible to coordinate his equipment and systems and shall show these on the drawings submitted.
 3. After each Contractor has fulfilled his obligation, he shall return the drawings to the HVAC Contractor. After each drawing has been coordinated between trades, and appropriate revisions made, each trade shall sign each drawing, indicating acceptance of the installation.
 4. The HVAC Contractor shall then print the coordination original and these prints submitted through the General Contractor to the architect for review and comment, similar to shop drawings. Comments made on these drawings shall result in a correction and re-submittal of the drawings.
- C. Furnish to other trades, as required, all necessary templates, patterns, setting plans, and shop details for the proper installation of work and for the purpose of coordinating adjacent work.
- 1.19 PROJECT RECORD DOCUMENTS:
- A. Each Contractor shall record clearly, neatly, accurately, and promptly as work progresses the following data:
 1. Changes made resulting from change orders or instructions issued by the Architect.
 2. Changes in routing made to avoid conflict with other trades or structural conditions.
 3. Final location of equipment and panels if different than contract documents.
 - B. Upon completion of the project submit to the Architect a set of electronic media noting "as built" conditions indicating all variations and deviations of his work from contract documents.
- 1.20 OPERATING INSTRUCTIONS AND MAINTENANCE MANUALS
- A. Operating Instructions: Provide operating instructions to the Owner's designated representative with respect to the operation functions and maintenance procedures for all equipment and systems installed. The cost of providing a manufacturer's representative at the site for instructional purposes shall be included in the Contract Price.
 - B. Maintenance Manuals: At the completion of the project, turn over to the General Contractor four (4) complete manuals in 3-ring binders, indexed, containing the following:
 1. Complete shop drawings of all material and equipment of this section.
 2. Operation descriptions of all systems.
 3. Names, addresses and telephone numbers of all suppliers of system components.
 4. Preventative maintenance instructions for all systems.
 5. Spare parts list of all system components.
 6. Copies of all valve charts.
- 1.21 PROTECTION
- A. Protect all work and material from damage by work and workmen, and accept liability for all damage thus caused.
 - B. Be responsible for work and equipment until finally inspected, tested, and accepted. Protect work against theft, injury or damage; and carefully store material and equipment received on site, which is not immediately installed. Close open ends of work with temporary covers or plugs during storage and construction to prevent entry of obstructing material.

- C. All openings in stored & installed ductwork shall be covered & sealed when not in use to prevent contamination from dust & debris.

1.22 SCAFFOLDING, RIGGING AND HOISTING

- A. Provide scaffolding, rigging, hoisting and services necessary for delivery, erection and installation of material, equipment and apparatus furnished under this division. Remove same from premises upon completion of work.
- B. Coordinate propose routing with architect prior to rigging and protect all existing building components against damage.

1.23 MATERIALS AND WORKMANSHIP

- A. All materials and apparatus required for the work, except as specifically specified otherwise, shall be new, of first-class quality, and shall be furnished, delivered, erected, connected and finished in every detail, and shall be so selected and arranged as to fit properly into the building spaces. Where no specific kind or quality of material is given, a first-class standard article as approved by the Architect shall be furnished.
- B. Furnish the services of an experienced foreman who shall be constantly in charge of the installation of the work, together with all skilled workmen, fitters, metal workers, welder, helpers, and labor required to unload, transfer, erect, connect, adjust, start, operate, and test each system.
- C. All equipment and materials shall be installed in strict accordance with the manufacturer's recommended installation instructions as well as UL Listing instructions and all Local, State and National codes.

1.24 QUIET OPERATION AND VIBRATION

- A. Work shall operate under all conditions of load without any objectionable sound or vibration. In case of moving machinery, sound, or vibration noticeable outside of room in which it is installed, or annoyingly noticeable inside its own room, will be considered objectionable. Sound or vibration conditions considered objectionable shall be corrected in an approved manner at no expense to the Owner. Vibration control shall be means of approved vibration eliminators in a manner as recommended by the manufacturer of the eliminators.

1.25 ACCESSIBILITY

- A. Assure and be responsible for the adequacy of shafts and chases, the adequate clearance in double partitions and hung ceilings for the proper installation of the work. Cooperate with all other trades whose work is in the same space. Such spaces and clearances shall, however, be kept to the minimum size required.
- B. Locate all equipment, which must be serviced, operated, adjusted or maintained fully accessible positions. Equipment shall include, but not be limited to, valves, traps, cleanouts, motors, controllers, filters, dampers, starters, coils, fire dampers, smoke dampers and drain points. If required for better accessibility, furnish access doors for this purpose. Minor deviations from drawings may be made to allow for better accessibility, and the engineer shall approve any change.
- C. Provide access panels for installation in concrete block walls or gypsum wallboard ceilings and partitions in locations, which require access for service to the items located behind the permanent gypsum wallboard or concrete block finish.
- D. Access panels shall be installed where required to gain access to valves, dampers, controls, etc. Panels shall be flush, insulated, contain continuous steel hinge and screwdriver operated latch. Panels shall be rated equal to the assembly that they are being installed in panels shall be UL listed.

- E. Access panels located in fire rated partitions shall be fire panels. The frame and panel assembly of these fire panels shall be manufactured under the Factory Inspection Service of the Underwriters' Laboratories, Inc., and shall bear a label reading: "Frame and Fire Panel Assembly, Rating 2 hours. (B) Temperature Rise 30 Minutes, 250° F. Maximum." Rated panels shall be equipped with automatic closing mechanism and be self-latching.
- F. Panels shall be provided with screwdriver operated flush cam locks.
- G. Panel size shall be 12 inches x 12 inches except furnish a larger size if required to service a particular item. The exact location and size of each access panel shall be reviewed with, and approved by, the Engineer.
- H. The exact location and size of each access panel shall be noted on a shop drawing and reviewed with, and approved by, the Architect and Engineer in writing prior to installation.

1.26 CUTTING AND PATCHING

- A. Provide all cutting and patching necessary to install the work specified in this division. Patching shall match adjacent surfaces.
- B. At floor slabs & wall openings to be cored drilled or cut, contractor shall find and mark on both faces all reinforcing, rebar, conduits, utilities, etc.. by means of x-ray, pach-ometer or prof-ometer. Submit sketch showing locations of all findings and proposed cuts or cores for review.
- C. No structural members shall be cut without the approval of the Structural Engineer, and all such cutting shall be accomplished in a manner directed by the Structural Engineer.

1.27 GROUNDING

- A. All components of mechanical piping systems shall be properly grounded to building ground. Where ground path is interrupted by non-conductive materials, appropriate bonding or grounding to building ground shall be provided.

1.28 WATERPROOFING

- A. Where any work pierces waterproofing including waterproof concrete, the method of installation shall be as approved by the Architect before work is started. Furnish all necessary sleeves required.

1.29 BUILDING EXPANSION JOINTS

- A. Where ductwork or piping crosses a building expansion joint provisions shall be made to allow for the movement of each side of the structure without adversely impacting the integrity of the ductwork or piping.
- B. Ductwork crossing a building expansion joint expansion joint shall be provided with a flexible connection as indicated in these specifications and allow for a minimum of 3x the expected maximum relative deflection between the two building sections.
- C. Piping crossing a building expansion joint shall be provided with an expansion joint as indicated in these specifications and allow for a minimum of 4x the expected maximum relative deflection between the two building sections.
- D. Ductwork and piping shall be rigidly affixed to the structure on either side of the building expansion joint.
- E. Flexible connections and piping expansion joints shall be suitable for the fluid type and pressure being transferred.

1.30 DESIGN BUILD PROVISIONS (WHERE APPLICABLE)

- A. The Work will be performed based on a Design/Build approach in which the Mechanical Subcontractor provides the engineering needed to satisfy performance criteria and other requirements listed herein. The criteria and requirements are meant to establish the general intent and do not always give specific sizes and types. This proposal must therefore include both system design and engineering services.
- B. Shop Drawings shall clearly describe the limits of the Work and identify related work by other trades. Work that the Mechanical Subcontractor requires to be done by other trades should also be noted. Formal coordination drawings will not be produced. Instead each major subcontractor will circulate their drawings to the other trades for review and comments. This will conclude with a coordination meeting in which all conflicts will be identified and resolved.
- C. The responsibility to insure that all Work items fit in the space available lies with the Mechanical Subcontractor. The Shop Drawings must in turn include dimensioned details drawn to scale.
- D. The Mechanical Subcontractor shall revise the Shop Drawings to include all required changes. Final revised drawings shall be issued prior to starting work.

1.31 TEMPORARY HEAT

- A. The building must remain in full operation during the construction period. This contractor shall provide temporary space conditioning, hot water heating, and/or domestic water production for the duration of time which the existing systems are inoperable or have owner approval for any downtime.
- B. This contractor shall provide a minimum of 48 hours' notice of any shutdowns and coordinate maximum allowable system downtimes with the Owner and/or Director of Operations prior to the start of work.
- C. This contractor shall be responsible for providing temporary heating equipment at any point during construction as required to maintain laborer comfort and avoid damage to the building or any of its associated components, systems, or equipment.
- D. Contractor shall provide all temporary or permanent equipment, materials, and labor to ensure these stipulations are met.
- E. Temporary heating requirements shall be coordinated with the electrical and plumbing contractor as required. This contractor shall carry all costs associated with utilizing other contractors to provide materials or labor for temporary services indicated above.

PART 2: PRODUCTS

2.1 IDENTIFICATION, MARKING AND TAGGING

- A. Systems and equipment to be identified and marked and valves tagged include, but are not limited to the Heating, Air Conditioning & Ventilating systems.
- B. Submit samples of marking and tagging devices and wording, lettering and numbering scheme for each system.
- C. Equipment Identification:
 - 1. Manufacturer's nameplates or trademark shall be permanently affixed to all equipment and materials furnished under this division. Manufacturer's nameplates shall include all pertinent data relative to the piece of equipment including model number, serial number, and operating characteristics as applicable.
 - 2. Separate Equipment Identification Markers shall identify each item of equipment with a permanently attached marker indicating designation and/or number corresponding

to design documents.

3. Markers shall be of rigid black Bakelite or phenolic construction with white engraved or incised letters.
4. Lettering on equipment markers shall be of adequate size to be legible from floor levels. In all cases marker lettering shall no be less than 1 inch high.

D. Piping System Identification:

1. Piping Systems shall be identified as indicated herein or as required by applicable codes and/or officials having jurisdiction.
2. Pipe Markers shall be color coded according to " Designations to Colors" - ASME A13.1-2007.
3. All piping and equipment shall be identified by pipe markings, which shall be provided by this Contractor. Markers shall be applied every 20 ft. Markings shall indicate pipe content, system, operating pressure & temperature, and direction of flow. The markers shall be as manufactured by Seton Name Plate Corp. or equal
4. Pipe Markers shall be of the pressure sensitive type as manufactured by the Seton Nameplate Corp. (F10-Code)
5. Valve Identification: Provide laminated plastic nameplates on all valves installed under Division 23, except stop valves in supplies to fixtures. Tags shall be constructed of 0.125 inches thick melamine plastic conforming to Fed. Spec. L-P-387. Surface shall be matte finish. Accurately align lettering and engrave into white core. Nameplates shall be to 2 inches round or hexagonal. Lettering shall be minimum of 0.375 inch high normal block lettering. Key the nameplates to a chart and schedule for each system. Frame one chart and schedule for each system under glass and place where directed in mechanical room. Furnish four copies of each chart and schedule. Each inscription shall identify its function. Attach nameplates with "S" hooks and chain to each valve. Valve nameplates shall be numbered and "keyed".

2.2 SLEEVES, INSERTS AND ESCUTCHEONS

- A. Provide sleeves for all work passing through floor, wall, and ceiling construction. Locate and provide sleeves and inserts before the floor, wall or ceiling is constructed. If this contractor does not comply with the above, he shall bear all costs incurred for cutting and patching required for the installation of sleeves and inserts. Holes required for sleeves in existing walls and floors, or to conform to the above shall be saw cut or core drilled. This Contractor shall provide all drilling required for the installation of hangers.
- B. Pipe sleeves through outside walls shall be Schedule 80 black steel pipe with 150 lb. black steel slip-on welded flanges welded at the center of the outside. Extend sleeves 1/2 inch beyond each side of the wall. Pack the space between sleeve and pipe with oakum to within 2 inches of each face of the wall. Pack the remaining space and make watertight with an approved waterproof compound.
- C. Pipe sleeves through concrete floors or interior masonry walls shall be Schedule 40 black steel pipe, set flush with finished wall or ceiling surfaces, but extending 2 inches above finished floors. Plastic, PVC, or light metal sleeves shall not be installed.
- D. Provide individual or strip type inserts pressed steel construction with accommodation for removable nuts and threaded rods up to 3/4-inch diameter, permitting lateral adjustment. Individual inserts shall have an opening at the top to allow reinforcing rods to 1/2 inch diameter to be passed through the insert body. Strip inserts shall have attached rods with hooded ends to allow fastening to reinforcing rods.
- E. Where pipe motion due to expansion and contraction will occur, make sleeves of sufficient

diameter to permit free movement of pipe. Where sleeves pass insulated pipes, the sleeves shall be large enough to pass the pipe and the insulation. Check floor and wall construction finishes to determine proper length of sleeves for various locations.

- F. Provide 22 gauge galvanized steel duct sleeves through interior walls, floors and ceilings set flush with finished surfaces.
- G. Pack the space between sleeves and structure, and sleeves and pipes or ducts passing through fire rated interior walls, floors, and ceilings with an approved fire and smoke proof packing material. Fire-stopping material shall maintain its dimensions and integrity while preventing the passage of flame, smoke, and gases under conditions of installation and user when exposed to the ASTM E119 time-temperature curve for a time period equivalent to the rating of the assembly penetrated. Cotton waste shall not ignite when placed in contact with the non-fire side during the test. Fire-stopping material shall be non-combustible as defined by ASTM E136; and in addition, for insulation materials, melt point shall be a minimum of 1700 degrees F. for 1-hour protection and 1850 degrees F. for 2-hour protection.
- H. Fasten sleeves securely in floors, walls, etc. so that they will not become displaced when concrete is poured or when construction is built around them. Take precautions to prevent concrete, plaster, or other materials being forced into the space between pipe and sleeve during construction.
- I. In all areas where ducts are exposed and pass through floors, the hole shall be surrounded by a 4-inch high by 3-inch wide concrete curb, or otherwise protected as determined by the Engineer.
- J. Escutcheon plates shall be provided for all exposed un-insulated pipes passing through walls, floors, and ceilings. Plates shall be nickel plated, of the split ring type, of size to match the pipe. Where plates are provided for pipes passing through sleeves, which extend above the floor surface, provide deep recessed plates to conceal pipe sleeves.

2.3 SUPPORTS & ATTACHMENTS

- A. Provide all necessary supports and bases required for all equipment, piping and for all other equipment furnished under this contract. Submit shop drawings to the Architect for approval before purchase, fabrication or construction of same.
- B. All equipment, unless shown otherwise, shall be securely attached to the building structure in an approved manner. Attachments shall be of a strong and durable nature and any attachments that are not strong enough shall be replaced as directed.
- C. Vibration Isolation: All mechanical equipment, piping and ductwork shall be mounted on vibration isolators/inertia bases to prevent the transmission of vibration and mechanically transmitted sound to the building structure.
 - 1. Vibration isolators shall be selected in accordance with the weight distribution so as to produce reasonably uniform deflections.
 - 2. All isolators and isolation materials shall be of the same manufacturer and shall be certified by the manufacturer.

2.4 SEISMIC RESTRAINTS

- A. It is the intent of this seismic specification that this contractor shall provide all necessary seismic restraints required to keep all mechanical building system components in place during a seismic event as required by the Building Code.
- B. All mechanical systems must be installed in strict accordance with seismic codes, component manufacturer's and building construction standards. Whenever a conflict occurs between the manufacturer's or construction standards, the most stringent shall apply.
- C. This contractor shall engage a professional structural engineer registered in the jurisdiction of

this project to review the entire installation to determine all seismic restraint requirements and methods. Contractor shall submit a report outlining the structural engineer's review as well as seismic restraint shop drawings and supporting calculations prepared by the professional structural engineer for review by the Architect.

1. Any questions relative to Component Importance factors shall be issued to the Architect/Engineer for resolution prior to seismic analysis.
- D. Seismic restraints shall be designed in accordance with seismic force levels as detailed in the applicable building code.

2.5 ELECTRIC MOTORS/STARTERS/VARIABLE FREQUENCY DRIVES

- A. Electric motors and starters shall conform to requirements of the AIEE, NEMA, UL, and NEC and shall be suitable for load duty, voltage, phase, frequency, service and location required. Provide inverter duty rated motors for use with variable frequency drives. Provide shaft grounding rings for all VFD controlled motors.
- B. All motors shall be rated at 85% power factor at full rated load. Motors less than 85% power factor shall be corrected to 90% power factor at the factory. All motors shall be rated high efficiency.
- C. Starters shall be Cerus International or equal.
 1. Enclosed Non-Combination Starter
 - a) Motor Starter shall be enclosed in a Type 1 or Type 4 UL rated enclosure.
 - b) Motor Starter shall be rated for NEMA class B motors for AC-3 switching and AC-4 switching.
 - c) Controls and annunciation shall include Hand- OFF- Auto keypad. LED indication shall include Hand, Off, Auto, Run and Overload. Overload reset shall be available.
 - d) Control inputs shall include: Auto Wet input, Auto Dry input, Permissive Auto input, Damper Status Input and Override Input. Automatic control inputs shall be capable of accepting a transistorized input without the need for interposing relays. Wet control inputs shall accept AC or DC inputs from 10 to 138VAC or DC.
 - e) Damper control shall be built into the starter to provide 24VAC or 120VAC damper control and monitoring.
 - f) Override input shall disable the starter from operating in either Hand or Auto mode.
 - g) Protective Functions
 - (i) Electronic Overload shall provide phase failure and phase loss protection, stall, and class 1 - 30 selectable overload protection. Phase failure protection shall initiate when phase loss is greater than 70% for 3 seconds or phase unbalance is greater than 50% for more than 5 seconds.
 - (ii) Cycling fault protection shall be integral to the starter. Cycling fault shall be enabled whenever the starter is cycled more than 1000 times in a one hour period. This feature shall be selectable to be disabled. Cycling fault shall cause overload LED to blink rapidly.
 2. Enclosed Combination Starter
 - a) Enclosed combination starter shall include all of the above descriptions in addition to either a motor circuit protector with lock-out mechanism, a UL 508 breaker, or a fused disconnect with lock-out mechanism.

- b) The Motor Circuit protector shall be a UL listed 508 manual motor starter with magnetic trip elements only. The breaker and shall carry a UL 508F rating (up to 100A frame size) which provides for coordinated short circuit rating for use with the motor contactor and provides an interrupting rating for the breaker and contactor combination.
- c) Fused disconnect shall be UL 98 suitable for service entrance protection.
- d) UL 508 breaker shall include thermal and magnetic trip mechanisms.

D. Variable Frequency Drives:

1. Furnish and install variable frequency drives as required by sequence of operation. Drives shall be provided with line reactors as required to eliminate harmonics transmitted upstream and downstream of drive and as required by local utility. Furnish VFDs with bypass to allow operation of motor in case of VFD failure. Drives shall be commissioned and tested and a report prepared by a company specializing in the field. Division 26 will energize drives.
2. Ratings
 - a) The VFD must operate, without fault or failure, for the following 3-phase supply voltage range:
 - b) 200V units: 200 to 240V +/- 10%
3. The VFD shall function for an input supply frequency range between 48 and 65Hz.
4. Phase imbalance: The VFD shall function for up to 2% negative phase sequence (equivalent to 3% tolerance of voltage imbalance between phases)
5. Displacement Power Factor (Cos ϕ): Greater than 0.97 over the entire ranges of operating speed and load.
6. Operating Ambient Temperature range: 0° C to 40° C (32° F to 104° F) continuous. Operation at 50° C (122° F) shall be possible with de-rating
7. Storage Temperature: -40° C to 50° C (-40° F to 122° F)
8. Humidity: 0% to 95% non-condensing at 40° C.
9. Altitude: 0 to 3,300 feet, without any de-rating. Above 3,300 feet operation shall be possible with 1% current de-rating for every additional 328 feet.
10. Minimum Efficiency: 96% at full speed
11. Overload capability: The full load continuous output current rating of the VFD must meet or exceed that of the motor nameplate full load amp rating. The VFDs shall be able to provide 110% of drive rated current for 60 seconds and 225% of drive rated current as instantaneous overload.
12. Total Harmonic Distortion (THD) compliance:
13. Given the information provided by the customer's electric power single line diagram and distribution transformer data, the VFD manufacturer shall carry out a Harmonic estimation for the system. The Harmonic estimation reviews the potential for the proposed equipment, and any existing equipment, to meet IEEE 519, latest version, (tables 10.2 and 10.3) recommendations at the Point of Common Coupling (PCC). The result of the Harmonic estimation shall determine if additional power quality improvement measures should be included in the proposal to meet the THD recommendations of IEEE 519. The PCC shall be at the primary side of the main distribution transformer.
14. VFDs must be rated for a symmetrical short circuit rating of 100 kA RMS
15. Carrier (Switching) Frequency:

- a) The VFD shall be selected for operation at carrier frequencies at or above 3 kHz to satisfy the conditions for current, voltage, and horsepower as indicated on the equipment schedule. Higher carrier frequencies shall be possible for quieter operation.
 - b) VFD shall have an adjustable carrier frequency with the ability to adjust while the VFD is running. It shall include automatic carrier frequency reduction to reduce tripping in the event of high temperature operation.
16. The VFD shall have a built-in AC or DC reactor equivalent to 3% of line impedance or else must include an equivalent external line reactor in order to protect from AC line transients & to reduce harmonics.
17. The VFD shall include an onboard EMC/RFI filter meeting CE and EN61800-3 standard for First Environment restricted level.
18. Serial Communications / Field bus options: All VFDs shall have a built-in RS-485 port.
- a) VFD shall have embedded Modbus RTU, BACnet and Johnson Controls Metasys N2 protocols as standard for building automation systems network communications accessible via a RS-485 communication port.
 - b) Optional protocols shall include LonWorks, Ethernet, DeviceNet and Profibus.
 - c) Use of third party gateways, multiplexers or non-certified protocols is not acceptable.
 - d) Serial communication capabilities shall include setting and saving parameter values, controlling operation such as Start/Stop and speed adjustment and monitoring faults and feedback.
19. VFD shall include programmable electronic thermal overload protection for both the drive and motor. The electronic thermal motor overload shall be approved by UL. VFDs without a UL Listed will not be accepted.
20. The VFD shall include a fireman's override input. This mode shall override all other control modes (analog, digital, serial and keypad commands) and the motor shall run at an adjustable preset speed. The keypad shall display 'Override Mode' status. Upon removal of the override signal, normal operation shall be resumed.
21. Three Contactor Electronic Bypass shall be provided when indicated by the schedule. VFD and bypass components shall be mounted, fully pre-wired, tested and made available for installation as one UL listed assembly by the drive manufacturer.
22. Integral Soft Start on transfer to bypass shall be offered as an option if required by the schedule.
23. The enclosure shall be of one of the following types depending on the schedule:
- a) NEMA 1 extended enclosure, to house additional equipment within the VFD enclosure for VFDs not requiring Bypass.
 - b) UL 1A Positive Pressure, Blown & Filtered (PPBF) enclosures with filters and blower.
 - c) NEMA 3R enclosures for outdoor installations.
- E. Disconnects provided by this contractor will be installed by Division 26, with the exception of factory mounted disconnects.
- F. Motors smaller than 1/2 HP shall be capacitor-start or split phase type, single phase, 60-hertz alternating current for voltage required. Motors 1/2 HP and larger shall be squirrel-cage

induction three phase 60 hertz alternating current for voltage required, unless specifically noted otherwise.

- G. Where available, starters and disconnects shall be factory mounted by the unit manufacturer.

2.6 USE OF INSTALLATION

- A. The Owners shall have the privilege of using any part of the installation when sufficiently complete, but such use thereof, or partial or final payment shall not be considered as an acceptance of such work in lieu of a written certificate from the Engineer.

2.7 DUCTWORK

- A. Fabricate and support in accordance with SMACNA HVAC Duct Construction Standards - Metal and Flexible, and as indicated. Provide duct material, gages, reinforcing, supports and sealing for operating pressures indicated.
- B. Duct gauge shall be as required by SMACNA Duct Construction Standards taking into account duct size, supports, pressure rating, and any other relevant parameters. All ductwork, regardless of SMACNA Standards, shall be no thinner than 26 gauge.
- C. Galvanized Steel Ducts: ASTM A525 and ASTM A527 galvanized steel sheet, lock-forming quality, having G90 zinc coating of in conformance with ASTM A90.
1. Sealant: As recommended by manufacturer specifically for sealing joints and seams in ductwork.
 2. Non-hardening, water resistant, fire resistive, compatible with mating materials; liquid used alone or with tape, or heavy mastic.
 3. Hanger Rod: ASTM A36; steel, galvanized; threaded both ends, threaded one end, or continuously threaded.
- D. Round Exposed Ductwork: Provide a complete double wall, spiral wound, round ductwork system as designed on the drawings with all necessary fittings, hangers, supports, turning vanes, and all other appurtenances for the installation of an operable system. All ductwork and fittings shall be galvanized sheet metal in accordance with ASTM-A527 specifications. Ductwork shall be of round spiral lockseam construction.
- E. Underground/Buried Ductwork: Equal to McGill Airflow Uni-Coat. Spiral round, lock seam construction with double corrugation. Elbows shall be Uni-seam standing seam or solid-welded seam for sizes 8"-30" and riveted and seal with water based sealer for larger sizes. Material shall be ASTM A653 and A924 galvanized steel with G-60 zinc coating and 4-mil-thick (0.004") coating of PVC plastic heat sealed to both sides of the metal. Touch-up paint shall be factory applied to any portions of metal exposed during fabrication.
- F. Hanger Rod: ASTM A36; steel, galvanized; threaded both ends, threaded one end, or continuously threaded.
- G. Flexible Ductwork: Duct shall be Flexmaster Triple Lock Buck Insulated Duct as manufactured by Buckley Associates or approved equal.
1. Flexible duct shall be Underwriters Laboratory Listed (UL 181 Class 0 Airduct) and constructed in accordance with NFPA Standards 90A and 90B. It shall have a smoke/flame spread rating of 50/25.
 2. Flexible Ductwork shall be made from a tape of dead soft aluminum sheet, spiral wound into a tube and spiral corrugated to provide strength and stability. The joint shall consist of a triple lock that is mechanically performed without the use of adhesives to make a durable airstream seam. A double lock is not acceptable.

3. Insulated flex shall have a fire retardant polyethylene outer jacket with a 1/2 lb. density, 1-1/2" thick fiberglass insulation blanket, factory wrapped.
4. The flexible duct shall be supported as required to prevent sagging. Flexible duct with excessive sagging will not be approved.
5. Flexible ductwork shall be rated at 12" positive pressure and 12" negative pressure for sizes up to 16". Negative pressure for 18" to 20" shall be 8".
6. Length of installed flexible duct shall not exceed 6'-0" in developed length.

H. Flexible Connections

1. Flexible connections shall be provided where a fan connects to a duct or casings to prevent transmission of vibration to ductwork.
2. Flexible connections shall fit tightly around ducts and fans and be securely bolted or clamped in place. Taping shall not be allowed.
3. Flexible duct connections shall be 6" long and made of straight, waterproof, flame retardant fabric having a flame spread rating of not over 25 and a smoke development rating of not over 50

I. Dishwasher Exhaust Ductwork:

1. Discharge ductwork shall be 16 gauge stainless steel, waterproof and detergent-proof, all welded construction.
2. Provide 16 gauge stainless steel volume damper at each dishwasher discharge connection.
3. Pitch ductwork toward dishwasher.
4. Duct shall be #316/No. 4 finish for exposed areas and #304/No. 1 finish for concealed areas.

J. Kitchen Exhaust Ducts:

1. Ducts shall be constructed of and supported by no less than 18 ga. 304 stainless steel No. 4 finish for exposed areas or 16 ga. Carbon steel (where concealed).
2. All seams, joints, penetrations and connections shall have a liquid-tight external weld.
3. On horizontal ducts at least one 20 x 20 opening shall be provided for personnel entry. Where an opening of this size is not possible, openings large enough to permit thorough cleaning shall be provided at 12 ft intervals.
4. Cleanouts shall be installed at the base of all vertical rise elbows. Cleanouts shall be installed at the base of elbows for any change in elevation.
5. On vertical runs of ductwork where personnel entry is not possible, provide cleanouts on each floor.
6. Prefabricated grease exhaust duct shall be accepted in lieu of field fabricated ductwork. Prefabricated grease ducts shall be UL 1978 and/or UL 2221 rated. Duct shall be installed to maintain clearance to combustibles as required by the manufacturer's recommended installation instructions.
7. Factory Built Double Wall Grease Duct (Round & Rectangular)
 - a) Furnish double wall, factory built grease duct for use with Type I kitchen hoods, which conforms to the requirements of NFPA-96.
 - b) Products shall be ETL listed to UL-1978 and UL-2221 for venting air and grease vapors from commercial cooking operation when installed in accordance with these instructions and National Fire Protection Association

"NFPA 96"; Standard for Ventilation Control and Fire Protection of Commercial Cooking Operations.

- c) Double wall grease ducts are listed for a continuous internal temperature of 500 degrees F and intermittent temperatures of 2000 degrees F.
- d) The duct sections shall be constructed of an inner duct wall and an outer wall with insulation in between. The inner duct wall shall be constructed in stainless steel.
- e) The outer wall shall be constructed of stainless steel.
- f) The duct shall include layers of Super Wool 607 Plus, Insulfrax Elite Blanket insulation, or Unifrax S16 Bulk Fiber insulation between the inner and outer wall.
- g) The duct wall assembly shall be tested and listed at 0" clearance to combustible materials and 0" clearance to non-combustible materials.
- h) Ductwork installed inside the building and shall be field measured by factory representatives, factory fabricated, and installed by the mechanical contractor in strict accordance with the manufacturer's recommendations and product UL listing.
- i) Double wall grease duct shall be Captive Aire model DW-3Z, Jeremias model DWCK-ZC, or approved equal.

8. Factory Built Single Wall Grease Duct

- a) Intended for use with Type I kitchen hoods, which conform to the requirements of NFPA-96.
- b) Grease duct shall be constructed of stainless steel and be available in diameters 5" through 36".
- c) Duct sections shall be held together in strict accordance with manufacturers recommended installation instructions.
- d) Duct joints shall be sealed with 3M Fire Barrier 2000+.
- e) Ductwork installed inside the building and shall be field measured by factory representatives, factory fabricated, and installed by the mechanical contractor in strict accordance with the manufacturer's recommendations and product UL listing.
- f) Grease duct shall be Captive Aire single wall ductwork, Jeremias model SWCK, or approved equal.
- g) Single Wall Grease ductwork shall be installed a minimum of 18" from combustible materials and 3" from limited combustible materials unless covered with fire wrap.

K. Fire Dampers:

- 1. Provide fire dampers throughout air distribution system as required by applicable codes, standards and authorities. Provide access door for each fire damper of sufficient size to repair internal link. Fire dampers indicated on drawings may not fully represent the exact number required for this project. It is the Contractor's responsibility, at no additional cost to the Owner, to provide all required dampers.
- 2. Dampers shall be approved fusible-link self-closing spring loaded type, Buckley Model 150B or equal.
- 3. Dampers shall be dynamic type when serving a system that is not shut down during fire alarm activation.

4. Frame shall be fitted with angle iron stop and stainless steel spring latch, and shall be securely fastened to building construction.
5. Seal spaces between damper frames and walls and between damper frames and floor with approved fire-retardant material.
6. Use of dampers shall NOT reduce net free area of duct below that shown on drawings. Fire dampers shall be Type B with blades of dampers out of air stream.
7. Samples of fire dampers shall be submitted to and approved by local authorities having jurisdiction.
8. Dampers shall bear 1-1/2 hour UL-rating fire damper label and shall be constructed and installed as required by UL-555.
9. Fire dampers shall be Buckley, Ruskin, Nailor Industries or Prefco for use in the proper duct pressure classification.
10. Dampers shall be installed per SMACNA with breakaway connections and nose pieces on duct liner (see SMACNA HVAC Duct Construction Standards).
11. All dampers in ductwork served by equipment not subject to fan shut down upon fire alarm activation shall be dynamic type.

L. Combination Fire/Smoke Dampers

1. Dampers shall meet the requirements of NFPA 80, 90A, 92, 101 and 105. Dampers shall be classified by Underwriter's Laboratories and labeled as a 1 1/2 hour Fire Damper under UL 555 and as a Class I or Class II Smoke Damper under UL 555S at an elevated temperature of 250°F (121°C) for use in dynamic or static Smoke Control Systems.
2. Dampers shall be tested under UL 555 and UL 555S by UL to a minimum velocity/pressure rating of 2000 fpm @ 4" w.g.
3. Frame shall be constructed of 16 ga. (1.6) galvanized steel hat channel with mitered corners reinforced with die-formed corner gussets for strength. Blades shall be 14 ga. (2.0) equivalent galvanized steel formed double-skin airfoil design on 5 1/2" (140) centers.
4. Dampers shall be of opposed blade configuration with an interlocking blade design that provides complete flame and smoke seal under fire conditions at an elevated temperature of 2000°F (1093°C) when in the closed position. Dampers requiring blade seals to maintain leakage class when under elevated temperature conditions are not acceptable. Blade linkage shall be zero-maintenance, concealed in frame, out of airstream. Jamb seals shall be compression type stainless steel.
5. Dampers shall be supplied with factory installed sleeves, length dependent on wall thickness, minimum 16" (406). Wall thickness shall be field verified by contractor. Where dampers are installed adjacent to a supply or return grille the sleeves shall be specifically designed for this installation.
6. Appropriate internally mounted Electric Resettable Link actuators shall be installed by the damper manufacturer in the factory. Actuators shall incorporate an OEM internal spring return mechanism; external after-market spring mechanisms are not acceptable.
7. Each damper shall be equipped with a UL Classified heat responsive device that will cause the damper to close in a controlled manner and lock in a closed position by means of an over center/knee lock linkage, when the duct temperature reaches the maximum degradation temperature of the damper/actuator assembly as required by UL 555S. Closure devices that cause instantaneous closure are not acceptable.

8. Submitted pressure drop data to be based on tests in accordance with AMCA Standard 500-D. Dampers must comply with the requirements of AMCA 511 Certified Ratings Program and be qualified to bear the AMCA Seal for Air Performance.
9. Standard of acceptance shall be Nailor Industries Model Series 1220, 12221G or approved equal.
10. Wall and duct access doors shall be provided to allow for testing and maintenance.

M. Volume Dampers:

1. Provide Young Regulator manual adjustable rectangular opposed blade dampers for duct heights less than 12" with factory-installed locking hand quadrants extended 2" for all dampers installed in externally insulated duct:
 - a) On each supply, return and general duct take-off.
 - b) At each take-off to register, grille or diffuser (not all are shown on drawing).
2. Dampers are manufactured approximately 5/16" smaller in width and 1/8" smaller in height than size of duct in which they are installed; e.g., nominal damper size is 24" x 10"; actual size is approximately 23-11/16" x 9-7/8".
3. Damper frame shall be constructed of #6063 extruded aluminum reinforced channel with minimum thickness of .050". Opposed damper blades shall be #6063 extruded aluminum with minimum thickness of .050" and shall include reinforcing ribs. Each blade shall be supported in the damper frame by individual Teflon axle bearings, and shall be driven by stainless steel connecting slide linkage controlled by 3/8" square steel control shaft.
4. Note: All required volume dampers may not be indicated on drawings but dampers shall be provided as necessary for systems balancing.
5. Dampers 12" and larger in height shall be opposed multi-blade equal to Greenheck, Nailor or Vent Products.
6. Where dampers are inaccessible, use Young Rectangular locking type ceiling regulators and miter gear or worm gear for all horizontal dampers. Bearing coupling for bottom duct control may be used for shaft on vertical blade dampers. The 3/8" rod between ceiling regulator and damper shall be provided by Contractor.
7. Where dampers are to be located above hard ceilings Young Regulator Bowden Cable Control Dampers shall be utilized. Controllers (actuators) shall be of the concealed ceiling type. Controller type, finish & locations to be approved by architect prior to purchase & installation. The cable between the damper and controller shall be provided by the contractor.
8. Damper blades shall be two gauges heavier than adjoining ductwork, and shall be riveted to supporting rods. Hem over edges parallel to rods.
9. Brackets shall be galvanized metal, secured to ductwork with sheetmetal screw with locking quadrant arms (see seal class section for additional requirements). Provide 2" handle extension for all dampers on externally insulated ductwork.
10. Note: All required volume dampers may not be indicated on Drawings but dampers shall be provided as necessary for system balancing.
11. Constant Airflow Regulators (CAR Dampers)
 - a) Dampers shall solely operate on duct pressure and require no external power supply. Each regulator shall be pre-set and factory calibrated, requiring no field adjustment to the airflows as indicated on the schedule, and shall be rated for use in air temperatures ranging from -25° to 140°F (-32° to 60°C.)

- b) Constant Airflow Regulators shall be capable of maintaining constant airflow within +/- 10% of scheduled flow rates (15% for units 50 CFM or less), within the operating range of 0.2 to 0.8 in. w.g. differential pressure, or 0.6 to 2.4 in. w.g. on high-pressure models (CAR-II-HP), or 0.1 to 0.42 in. w.g. on low-pressure models (CAR-II-LP).
- c) Regulators shall be provided as an assembly consisting of a 94V-0 UL ABS plastic body housed within a round sleeve for mounting in round duct. Each round sleeve must be fitted with a lip gasket to ensure perimeter air tightness with the interior surface of the duct.
- d) All regulators must be classified per UL 2043 and carry the UL mark indicating compliance. All Constant Airflow Regulators will require no maintenance and must be warranted for a period of no less than five years. Constant Airflow Regulators shall be installed in tight ducting systems in accordance with all applicable codes and manufacturer's instructions.
- e) Provide Model CAR-II Constant Airflow Regulators by American ALDES Ventilation Corporation or approved equal.

2.8 AEROSEAL DUCT SEALING

A. Scope

- 1. All existing duct systems which are to be served, in part or in total, by new HVAC equipment shall be provided with Duct Sealing as indicated in this section.
- 2. Duct sealing shall be applied to supply, return, and exhaust duct systems as required above.

B. Duct Preparation

- 1. Inspect air distribution systems for major leakage sites and significant accumulation of hubris or debris.
- 2. Remove all debris and significant dust and dirt (>1/8 inch deep) in air distribution system using a NADCA approved duct cleaning method.
- 3. Ensure adequate structural support for new and existing ductwork, including structural integrity of all mechanical duct joints and transitions per SMACNA standards.
- 4. Temporarily remove or protect from aerosol particles building controls, fire and smoke sensors as recommended by manufacturer.
- 5. Temporarily disable fire alarms and notify appropriate authorities.
- 6. Temporarily isolate air-moving equipment and block off air inlets and outlets, and other devices and appurtenances as recommended by the manufacturer.
- 7. Protect occupied spaces from aerosol particles using manufacturer procedures.
- 8. All work shall be done in a substantial and workmanlike manner by factory trained technicians.

C. Duct Sealing

- 1. a. Repair all major leakage sites greater than ½ inch across using mastic and fiberglass mesh tape per SMACNA standards.
 - a) Mastic and fiberglass mesh tape shall meet UL 181 standards.
- 2. Seal existing ductwork from the inside using automated aerosolized sealant injection.
 - a) Manufacturer: Aero seal, LLC

- b) Application must be performed by a manufacturer approved service provider.
 - c) Sealant shall comply with UL Outline Scope 1381.
 - d) Sealant must cure with 2 hours with no VOC off-gassing thereafter.
 - e) Sealant shall remain elastic after curing.
 - f) Sealant shall be deposited substantially at areas of leakage only.
3. Provide pre-sealing, post-sealing and sealing profile reports for all duct sections sealed.
 4. Repair all injection and test holes in existing ductwork using patching plates sealed tight per SMACNA standards.
 5. Any injection ports in duct board shall be made and repaired using pumpkin-cuts.
 6. Any insulation (internal or external) shall be replaced on the patching plate.

D. Duct Testing

1. Following completion of air handling unit installations, duct repairs, and duct sealing, test all ductwork to insure that the air distribution system is properly sealed.
 - a) The supply ducts shall have air losses equal to or less than the Leakage Class indicated in Table 1.
 - b) The return ducts shall have air losses equal to or less than the Leakage Class indicated in Table 1.
 - c) The exhaust ducts shall have air losses equal to or less than the Leakage Class indicated in Table 1.

The SMACNA Leakage Class (CL) is determined using the following relationship:

$$CL = F/p^{0.65}$$

Where:

CL = Leakage Class, which is the *permissible leakage rate* in CFM per 100ft² of duct surface
 F = Leakage Factor, CFM per 100ft² of duct surface. Varies with s.p.
 p = Duct static pressure, in. w.g.

Duct Static Pressure Construction Class	1/2 in., 1 in. 2 in. w.g.	3 in. w.g.	4 in., 6 in., 10 in. w.g.
Seal Class	A*	A*	A*
Sealing Applicable	Transverse Joints, Seams, and all Applicable Duct Wall Penetrations	Transverse Joints, Seams, and all Applicable Duct Wall Penetrations	Transverse Joints, Seams, and all Applicable Duct Wall Penetrations
Leakage Class			
Rectangular Metal	16	8	4
Round Metal	8	4	2
Flexible Ducts	8	N/A	N/A
Ductboard	8	N/A	N/A
Masonry	8	N/A	N/A

*Aeroseal since it is applied to ductwork internally under pressure achieves Seal Class A Leak location is not relevant

D. Duct Reassembly and Cleanup

2. Reinstall building controls and smoke detectors.
3. Enable fire alarms and notify appropriate authorities.
4. Remove blocking, reinstall grills and registers, and enable air handling fans.

5. Cleanup sealant residue that may have adhered to surfaces in occupied areas as recommended by the Manufacturer.
6. All work shall be done in a substantial and workmanlike manner by factory-trained technicians.

E. Warranty

1. The Contractor shall warrant that the aerosol sealant application will be free from defects for a period of 3 years from date of the sealing application. If defects should occur during this period, the Contractor shall repair or replace the defective duct seals, including the direct labor costs for performing the repair or replacement, at no additional cost to the Owner.

2.9 B-VENT (For Category I (Atmospheric) Gas Appliances)

- A. The vent shall be of the double-wall, factory-built type for use with approved Category I appliances burning natural or LP gas, which produce flue gases exhausted at temperatures not exceeding 550° F.
- B. The vent shall be constructed of an outer wall of galvanized steel, .018" thick G-90 for sizes 3" to 14" diameter, and .024" thick G-90 for sizes 16" to 30" diameter. The inner wall shall be constructed of aluminum alloy, .012" thick for sizes 3" to 8" diameter and .018" thick for sizes 10" to 30" diameter. The vent shall include an integral, annular insulating air space, 1/4" thick for sizes 3" to 6" diameter and 1/2" thick for sizes 7" to 30" diameter.
- C. Edges of inner and outer walls shall be hemmed prior to final assembly to prevent pipe and fittings from having exposed sharp edges. Walls shall be attached to maintain spacing and prevent separation of inner and outer walls.
- D. The vent pipe shall incorporate a push-tab locking system to prevent disassembly of vent during or after installation.
- E. All fittings, flashing, storm collar, cap, and appliance adapter required to install the vent shall be included.
- F. Vent shall be tested and listed for a minimum clearance to combustibles of 1" for sizes 3" to 24" diameter and 2" for sizes 26" to 30" diameter.
- G. Vent shall terminate as required by code.
- H. B-Vent shall be installed in accordance with the vent manufacturer's installation instructions, UL listing and state or local codes.

2.10 CONDENSING PRESSURE STACK (For Category II, III, and IV Appliances)

- A. The vent shall be of the double-wall, factory-built type for use on condensing appliances or pressurized venting systems serving Category II, III or IV appliances or as specified by the equipment manufacturer.
- B. Maximum temperature shall not exceed 550°F (288°C).
- C. Vent shall be listed for an internal static pressure of 6" w.g. and tested to 15" w.g.
- D. Vent Construction:
 1. Vent shall be constructed with an inner and outer wall, with a 1" annular insulating air space.
 2. The inner wall shall be constructed of AL29-4C, or other UL 1738 approved stainless steel, and the outer casing wall (casing) shall be constructed of 304 stainless steel.
- E. All supports, roof or wall penetrations, terminations, appliance connectors and drain fittings, in 100% stainless steel construction, required to install the vent system shall be included.

- F. Roof penetration pieces shall be UL listed and provided by the vent manufacturer. Roof curbs shall be required on roofs greater than 12:12 pitch.
- G. Vent shall terminate in accordance with installation instructions and local codes.

2.11 DUCT INSULATION

A. Compliance: Insulation thickness, conductivity and installation shall comply with local Mechanical and Energy Codes. Where local code conflicts with specifications, the more stringent shall apply.

B. Definitions:

- 1. Conditioned Space: An area, room or space that is enclosed within the building thermal envelope and is directly or indirectly heated or cooled. Spaces are indirectly heated or cooled where they communicate through openings with conditioned spaces, where they are separated from conditioned spaces by uninsulated walls, floors, or ceilings or where they contain uninsulated ducts, piping or other sources of heating or cooling,
- 2. Unconditioned Space: An enclosed space within a building that is not a conditioned space or a semiheated space. Crawlspace, attics, and parking garages with natural or mechanical ventilation are not considered enclosed spaces.

C. Supply and Return Air Duct Insulation:

- 1. Insulation: ASTM C553; flexible, foil faced, noncombustible blanket.

- a) Exposed Conditioned

- (i) Supply Air: No Insulation Required
- (ii) Return Air: No Insulation Required
- (iii) Outside Air: No Insulation Required

- b) Concealed Conditioned

- (i) Supply Air: R-Value of 6.0 installed.
- (ii) Return Air: No Insulation Required
- (iii) Outside Air: R-Value of 6.0 installed.

- c) Unconditioned

- (i) Supply Air: R-Value of 8.0 installed.
- (ii) Return Air: R-Value of 8.0 installed.
- (iii) Outside Air: No Insulation Required

- 2. Vapor Barrier Jacket:

- a) Kraft paper with glass fiber yarn and bonded to aluminized film.

- (i) Moisture vapor transmission: ASTM E96; 0.02 perms.
- (ii) Secure with pressure sensitive tape.

- 3. Vapor Barrier Tape:

- a) Kraft paper reinforced with glass fiber yarn and bonded to aluminized film, with pressure sensitive rubber based adhesive.

D. Exhaust Ductwork Insulation:

- 1. Insulation: ASTM C553; flexible, foil faced, noncombustible blanket.
- 2. Direct Exhaust: No Insulation Required.

3. Upstream of an ERV:
 - a) Refer to Supply and Return Duct Insulation.
- E. Exterior Ductwork Insulation (All Types)
 1. R-Value of 12.0 installed.
 2. Jacket: Provide VentureClad or equal insulation jacketing system. Insulation jacket is a zero permeability, self-adhesive jacket. Color to be confirmed by Architect.
 3. Install per latest installation instructions from the manufacturer.
- F. Exterior Ductwork (All Types)
 1. Provide Pro-R pre-insulated outdoor HVAC ductwork system as manufactured by Ducts and Cleats or approved equal.
 2. Provide shop drawings indicating: Fabrication, assembly, and installation, including plans, elevations, sections, components, and attachments to other work.
 3. Inner Liner: UL (C-UL) 181 Standard for Safety listed, Class 1 System, with included testing and passing the following:
 - a) Test for Surface Burning Characteristics
 - b) Flame Penetration Test
 - c) Burning Test
 - d) Mold Growth and Humidity Test
 - e) Low Temperature Test and High Temperature Test
 - f) Pressure Test and Collapse (negative pressure) Test
 - g) High Temperature and Humidity for 90 days
 4. Metal Clad Phenolic Foam Ductwork
 - a) Duct Panel Core: Aluminum Foil Scrim Phenolic Foam Ductwork
 - b) Closed Cell CFC-free phenolic foam bonded on both sides with factory applied aluminum foil reinforced with fiberglass scrim.
 - c) Maximum Thermal Conductivity: 0.146 Btu · in/hr · sq. ft · deg F at 75F mean temperature.
 - d) R-Value 12: 1 3/4 inch (45mm) Thick Panel
 5. Exterior Cladding
 - a) Aluminum: UV stable, 0.040" Kynar 500 Pre-Finished aluminum.
 6. Duct sections shall be factory fabricated with gasketed TDC Flanges and Pittsburgh style seams
 7. Pressure Class: -10"up to 10" w.g.
 8. Air Leakage: Less than Class 3 @ 2" w.g.
 9. Fabrication Guidelines:
 - a) Joints, seams, transitions, reinforcement, elbows, branch connections, access doors and panels, and damage repairs fabricated according to manufacturer's written and detailed instructions.
 - b) Fabricated 90-degree mitered elbows to include turning.

- c) Internal seams will be supplied with an unbroken layer of low VOC silicone or bonding (for paint shop applications). Each duct segment will be factory supplied with TDC flange. Duct reinforcement to protect against side deformation from both positive and negative pressure per manufacturer's design guide based on specified ductwork size and system pressure.
 - d) Both positive and negative ductwork and fittings shall be constructed to incorporate a UL Listed as a Class 1 air duct to Standard for Safety UL 181 liner with an exterior clad for permanent protection against water intrusion.
10. Contractor to ensure that the ductwork system is properly and adequately supported per Pro-R® installation detail drawings provided prior to work commencement.
 11. Ductwork shall be supported at changes of direction, at branch duct connections, tee fittings, and all duct accessories such as dampers, etc. per SMACNA standards.
 12. Contractor shall be factory certified to install duct system. System shall be installed and supported in accordance with the manufacturers recommended installation instructions.

G. Fire Wrap

1. Provide fire wrap on Kitchen Exhaust Ductwork as indicated on drawings and/or after ductwork penetrates a fire barrier/partition or where proper clearance to combustibles (as required by NFPA 96 and local codes and ordinances) cannot be achieved.
2. Acceptable Manufacturer: Thermal Ceramics; 2102 Old Savannah Rd., Augusta, GA 30906. ASD. Toll Free Tel: (800) KAOWOOL. Tel: (706) 796-4200. Fax: (706) 796-4398. Email: firemaster@thermalceramics.com. Web: <http://www.thermalceramics.com>.
3. Substitute products shall demonstrate compliance with all sections of ASTM E 2336 and also have a current ESR report allowing their use on grease ducts for clearance reduction and also for fire-resistance-rated enclosures.
4. 2 Hour Applied Fire Protection for Commercial Kitchen Grease Ducts when tested in accordance with ASTM E 2336 – Passes all 5 Acceptance Criteria in Sections 16.1 to 16.5 – Reference ICC-ES Building Code Report ESR 2213, also reference UL Listing HNKT G-18.
5. 1 and 2 Hour Applied Fire Protection when tested in accordance with UL 1978; Compliant per UL Listing HNKT G14 (Single Layer Installation).
6. 1 and 2 Hour F- and T-Rated Through Penetration Firestop when tested in accordance with ASTM E 814 (UL 1479): UL Through Penetration listings; C-AJ-1562; C-AJ-7004; C-AJ-7012; C-AJ-7014; C-AJ-7019; C-AJ-7021; C-AJ-7047; C-AJ-7095; C-AJ-7098; C-AJ-7119; F-A-1093; F-A-1094; F-A-3048; F-C-7036; F-C-7037; W-L-7041; W-L-7099; W-L-7121; W-L-7145; W-J-7086.
7. 1 and 2 Hour Applied Fire Protection for Ventilation Air Duct when tested in accordance with ISO 6944-1985 - Reference UL Listings HNLV V19; HNLV V1; HNLV V2; HNLV V3; HNLV V4.
8. Thermal Material: 2000 F degree rated core blanket, manufactured from patented bio-soluble Superwool chemistry (Calcium Magnesium Silicate)
9. Product: FireMaster FastWrap XL as manufactured by Thermal Ceramics.

10. Fully encapsulated thermal material in fiberglass reinforced aluminum/polypropylene scrim.
 - a) Encapsulation material marked with UL Classification Mark
 - b) Encapsulation material marked with ICC-ES report number ESR 2213
 - c) Collars supplied in 6 inch (150 mm) wide by 25 feet (7620 mm) long rolls.
 11. Product Characteristics:
 - a) Thickness: 1-1/2 inch (38 mm).
 - b) Nominal Density: of 6 pcf
 - c) R-Value: 7.35 per layer of FireMaster FastWrap XL when tested in accordance with ASTM C 518.
 - d) Flame Spread: <25 when tested in accordance with ASTM E 84.
 - e) Smoke Development: <50 when tested in accordance with ASTM E 84.
 12. Glass Filament Tape: Minimum 3/4 inch (19 mm) wide – used to temporarily secure blanket until permanent attachment using steel banding and/or steel insulation pins.
 13. Aluminum Foil Tape: Minimum 3 inches (76 mm) used to seal cut edges.
 14. Carbon Steel or Stainless Strapping Material Minimum: 1/2 inch (13 mm) wide and 0.015 inch (.38 mm) thick
 15. Steel Insulation Pins: Minimum 12 gage, length sufficient to penetrate through duct wrap insulation.
 16. Insulation Clips: Galvanized steel, minimum 1-1/2 inches (38 mm) round or square.
 17. Through Penetration Firestop Sealants:
 - a) Packing Material: Remove encapsulation material from FastWrap XL, use core blanket (white) as penetration packing material.
 - b) Firestop sealants per applicable building code report and/or laboratory design listings.
 18. Grease Duct Access Doors:
 - a) Field fabricated access doors per Thermal Ceramics installation instructions.
 - b) Ductmate F2-HT Doors (NFPA 96 Compliant, tested with FireMaster FastWrap XL per ASTM E 2336)
 - c) Ductmate Ultimate Door (NFPA 96 Compliant, UL Listed per UL 1978, tested with FireMaster FastWrap XL per ASTM E 2336)
 - d) FireMaster Ductmate F2-HT-XL3 Access doors are supplied as a complete installation with DuctMate F2-HT Door and 3 layers of FastWrap XL insulation installed as tested in accordance with ASTM E 2336. Supplied in standard door sizes of 6 by10 inches (152 mm by 254 mm), 8 by12 inches (203 mm by 305 mm), 12 by16 inches (305 mm by 406 mm), and 14 by18 inches (356 mm by 457 mm).
- H. All duct insulation & wrap shall be installed per the manufacturer's application instructions. Provide mechanical fasteners to the bottom of ducts as required by the manufacturer.

2.12 INTERIOR DUCT LINER

- A. Polymer Foam insulation (EPFI) equal to IMCOA "IMCOSHEET" Engineered Polymer Foam Insulation, 1 inch thick, R = 4.0, closed cell. Insulation shall be installed as required by the insulation manufacturer. Insulation shall be in compliance with NFPA 90 and 90B. Flame spread shall be less than 25 and smoke density less than 50 per ASTM E-84, NFPA 255, UL 723 Class I and UL 181.
- B. Duct lining shall be applied in the following locations:
 - 1. 20' upstream and downstream from all air handling units exceeding 10 tons.
 - 2. 10' upstream and downstream from all air handling unit of 10 tons or less.
 - 3. 5' downstream from all other fan powered units including, but not limited to, fan powered VAV boxes.
- C. Areas provided with interior duct lining shall also be provided with exterior duct insulation as indicated by these specifications.

2.13 PIPING

- A. Equipment Drains and Overflows
 - 1. Copper Tubing: ASTM B88, Type L, hard drawn.
 - a) Fittings: ASME B16.18, cast brass, or ASME B16.22 solder wrought copper.
 - b) Joints: Solder, lead free, 95-5 tin-antimony, or tin and silver, with melting range 430 to 535 degrees F (220 to 280 degrees C) or Victaulic grooved joints.
 - 2. PVC Pipe: ASTM D1785, Schedule 40 and Schedule 80 for sizes 8 inch (200 mm) and larger or ASTM D2241, SDR 21 or 26.
 - a) Fittings: ASTM D2466 or D2467, PVC.
 - b) Joints: ASTM D2855, solvent weld.
- B. Unions, Flanges and Couplings
 - 1. Unions for Pipe 2 Inches (50 mm) and Under:
 - a) Ferrous Piping: 150 psig (1034 kPa) malleable iron, threaded.
 - b) Copper Pipe: Bronze, soldered joints.
- C. Refrigerant Piping Copper Tubing: ASTM B280, Type ACR hard drawn.
 - 1. Fittings: ASME B16.22 wrought copper.
 - 2. Joints: Braze, AWS A5.8 BCuP silver/phosphorus/copper alloy with melting range 1190 to 1480 degrees F.
 - 3. Provide all valves and accessories required for complete installation.
- D. Plenum Return Applications
 - 1. Where piping is installed in a return air plenum piping shall be plenum rated.
 - 2. PVC and/or PEX piping shall not be allowed in return air plenums.

2.14 VALVES

- A. Valve Features
 - 1. General Comply with ASME B31.9 for building services piping, and ASME
 - 2. Valve Design; Valves shall have rising stem, or rising outside screw and yoke stems; except, non-rising stem valves may be used where headroom prevents

full extension of rising stems.

3. Pressure and Temperature Ratings As scheduled and required to suit system pressures and temperatures.
4. Sizes unless otherwise indicated, provide valves of same size as upstream pipe size.
5. Operators Provide the following special operator features:
 - a) Hand wheels fastened to valve stem, for valves other than quarter turn, by brass nut on a square-topped stem.
 - b) Lever handles on quarter-turn valves 6 inch and smaller, except for plug valves. Provide one wrench for every 10-plug valves, and a one years supply of recommended lubricant or sealant.
 - c) Chain-wheel operators for valves 2-1/2 inch and larger installed 72 inches or higher above finished floor elevation. Extend chains to an elevation of 5'-0" above finished floor elevation.
 - d) Gear drive operators on quarter-turn valves 8 inches and larger.
6. Extended Stems where insulation is indicated or specified, provide extended stems arranged to receive insulation.
7. Bypass and Drain Connections: Comply with MSS SP-45 bypass and drain connections.
8. End Connections: As specified in the individual valves specifications.
9. Threads Comply with ANSI B2.1.
10. Flanges Comply with ANSI B16.1 for cast iron, ANSI B16.5 for steel, and ANSI B16.24 for bronze valves.
11. Solder-Joints Comply with ANSI B16.18.
12. Caution: Where soldered end connections are used, use solders having a melting point below 840 degrees. F for gate, globe, and check valves; below 421 degrees. F for ball valves.
13. Groove-Ended Valves Comply with AWWA C606

B. Gate Valves

1. Gate Valves - 2 Inch and Smaller MSS SP-80; Class 150, body and bonnet of ASTM B 62 cast bronze, threaded or solder ends, solid disc, gland packed, N.A. packing.

C. Ball Valves

1. Ball Valves – 1 Inch and Smaller Rated for 150 psi saturated steam pressure, 600 psi WOG pressure; 2-piece construction, bronze body conforming to ASTM B 62, standard (or regular) port, stainless steel ball, replaceable "Teflon" or "TFE" seats and seals, blowout proof stem, and vinyl-covered steel handle. Threaded ends for heating hot water and low-pressure steam.
2. Ball Valves - 1-1/4 Inch to 2 Inch Rated for 150 psi saturated steam pressure, 600 psi WOG pressure; 3-piece construction, bronze body conforming to ASTM B 62, conventional port, stainless steel ball, replaceable "Teflon" or "TFE" seats and seals, blowout proof stem, and vinyl-covered steel handle. Threaded ends for heating hot water and low-pressure steam.
3. Ball Valves-1/2 inch through 2inch Rated for up to 600 psi WOG, brass body, standard port, threaded ends, 2-piece, chrome-plated brass ball, TFE seats. Victaulic Style 722.

4. Ball Valves-1-1/2 inch through 6 inch. Rated for up to 1000 psi. ductile iron body, standard port, grooved ends, 2-piece, chrome-plated carbon steel ball, TFE seats. Victaulic Style 726.

D. Plug Valves

1. Plug Valves - 2 Inch and Smaller 150 psi WOG, bronze body, straightaway pattern, square head, threaded ends.
2. .

E. Globe Valves

1. Globe Valves - 2 Inch and Smaller MSS SP-80; Class 150, body and union bonnet of ASTM B 62 bronze, gland packed, N.A. packing. Bronze trim, composition disc.

F. Butterfly Valves

1. Butterfly Valves - 2 Inch and smaller MSS SP-67; 200 psi, cast bronze body, Viton seals, full port design, stainless steel trim, threaded or solder ends.

G. Check Valves

1. Swing Check Valves - 2 Inch and Smaller MSS SP-80; Class 150 or 200, cast bronze body and cap conforming to ASTM B 62, horizontal swing, with a Teflon disc, and having threaded ends. Valve shall be capable of being repaired while the valve remains in the line.
2. Lift Check Valves - 2 Inch and Smaller Class 125, cast bronze body and cap conforming to ASTM B 62, horizontal, lift type valve, bronze disc and threaded ends. Valve shall be capable of being refitted and ground while the valve remains in the line.

H. Combination Balancing & Shutoff Valves:

1. 2" and Smaller Sizes: 300 psi, threaded or sweat ends, non-ferrous Ametal® brass copper alloy body, EPDM o-ring seals. 4 turn digital readout handwheel for balancing, hidden memory feature with locking tamper-proof setting. Victaulic / TA Hydronics Series 786/787 or Engineer Approved Equal .

I. Balancing Valves

1. Balancing valves shall be provided on all piping mains and takeoffs as required to balance the system to the flows indicated on the drawings and in the equipment schedules.
2. Balancing valves shall be sized such that the specified flow through the valve generates an input to the flow measurement device that is within the range of accuracy of the device. Oversized valves that generate inputs that are below the range of the device and undersized valves that result in excessive pressure loss are not acceptable. Balancing valve submittals shall indicate size, flow and valve characteristics.

2.15 PIPING INSTALLATION

- A. Piping shall be inspected, tested and approved before being buried, covered or concealed. Horizontal piping shall be pitched with a minimum grade of one inch in 50 feet. Fittings shall be provided for changes in direction of piping, and for all connections. Fuel supply piping shall allow for ample tank movement and pipe expansion.
- B. Install piping free from traps and drain toward tank.

- C. Pipe Sleeves: Firmly pack space between the pipe or tubing, and sleeve with oakum and caulk on both ends of sleeve with elastic cement.
- D. Unions, Flanges and Victaulic Couplings: Place unions, flanges or Victaulic couplings where necessary to permit easy disconnection of piping and apparatus. Each connection having a screw end valve shall have a union.
- E. Valves: Install valves in positions accessible for operation and repair. Install check valve and an isolation valve on suction line of each fuel oil storage tank.
- F. Field Testing: Upon completion and before final acceptance of the work, each system shall be tested as in service to demonstrate conformance with the contract requirements and in accordance with the requirements of ANSI B31.3 and NFPA 30.
- G. Each new piping system will be hydrostatically tested at not less than 1.5 times the working pressure in accordance with ANSI B16.3, but in no case less than 200 psig and shall show no leakage or dials indicating not less than 1.5 times nor more than 2 times the test being placed in operation. Remove fuel quality monitor elements and water separator elements from filter separators before hydrostatic tests. Do not subject tank to pipe test pressures. Refer to tank manufacturers data for maximum test conditions.
- H. Contractor shall provide one full tank load of fuel oil of the proper grade after successful testing.
- I. Grooved Joints: Assemble joints with coupling and gasket, lubricant, and bolts. Cut or roll grooves in ends of pipe based on pipe and coupling manufacturer's written instructions for pipe wall thickness. Use grooved-end fittings and rigid or flexible, where required, grooved-end-pipe couplings. The gasket style and elastomeric material (grade) shall be verified as suitable for the intended service as specified. Gaskets shall be molded and produced by the grooved coupling manufacturer. Grooved end shall be clean and free from indentations, projections, and roll marks in the area from pipe end to groove. A Victaulic factory trained field representative shall provide on-site training for contractor's field personnel in the use of grooving tools, application of groove, and installation of grooved piping products. Factory trained representative shall periodically review the product installation. Contractor shall remove and replace any improperly installed products.
- J. Piping which contains any fluid which could potentially freeze is strictly prohibited from being installed within areas which may be subject to freezing temperatures. If, during the installation process, it is noted that such piping will be located in an area subject to freezing temperatures it must be brought immediately to the attention of the engineer. If such an installation is unavoidable affected piping shall be provided with additional insulation as required by the energy code as well as heat tracing and associated power circuiting as required to avoid the fluid freezing.

2.16 PIPING INSULATION

A. Insulation

- 1. Low Temperature Fluid Applications: Provide insulation with integral wick material. Product shall include a factory applied integral vapor retarder extending under the evaporator area of the wick and covering not less than 98% of the circumference of the product. Exposed evaporator area shall be not less than 0.1 sq. ft./linear ft. of product.
 - 2. Refrigerant Piping: Flexible closed cell insulation.
 - 3. Plenum Return Applications: All insulation, jackets and accessories shall be rated for use in return air plenums.
- B. Compliance: Insulation thickness, conductivity and installation shall comply with local Mechanical and Energy Codes.

C. Minimum Pipe Insulation:

1. Chilled Water/Cold Condensate/Refrigerant: 1-1/2" Thick, ≤ 1-1/2" Nominal Pipe Diameter
2. Chilled Water/Cold Condensate/Refrigerant: 1-1/2" Thick, > 1-1/2" Nominal Pipe Diameter

FLUID	NOMINAL PIPE DIAMETER	
	≤1.5"	>1.5"
Steam, Steam Condensate	1 1/2"	3"
Hot Water	1 1/2"	2"
Chilled Water, Cold Condensate, or Refrigerant	1 1/2"	1 1/2"

D. Condensate Piping

1. All condensate piping, regardless of temperature, shall be provided with insulation.
2. Condensate generated by cooling coils shall be considered Low Temperature Fluid.

E. Fittings: Factory precut insulation inserts, thickness to be same as adjacent. Enclose in premolded, PVC fitting covers.

1. Low Temperature Applications: Fittings and valves shall be wrapped continuously with wicking material prior to installing insulation to ensure a continuous path for removal of condensation.

F. Jackets:

1. Interior: Factory applied, all service jacket of white Kraft bonded to aluminum foil reinforced with fiberglass yarn and suitable for painting. Longitudinal and butt joints shall be made with factory applied pressure sensitive material.
2. Exterior/Exposed (Low Temperature): Field applied, 20 mil, PVC sheet material.
3. Exterior/Exposed (High Temperature): Field applied, Aluminum sheet material.
4. All jackets exposed to the weather shall be reflective, UV resistant and sealed watertight.

G. Preparation

1. Install materials after piping has been tested and approved.

H. Installation

1. Install materials in strict accordance with manufacturer's instructions.
2. Continue all insulation through penetrations.
3. In piping exposed to view, locate insulation and cover seams in least visible locations.
4. On piping that requires condensation control, (i.e. chilled or cold) insulate fittings, valves, unions, flanges, strainers, flexible connections, and expansion joints.
5. On piping not requiring condensation control (i.e. steam, condensate hot water) do not insulate flanges and unions at equipment, but bevel and seal ends of insulation at such locations.

6. Provide pipe insulation with weatherproof jacket on exterior piping that has heat trace.

I. Supports:

1. All piping shall be supported in such a manner that the insulation is not compromised by the hanger or the effects of the hanger. In all cases, hanger spacing shall be such that the circumferential joint may be made outside the hanger. Cover the evaporating holes with contractor supplied VaporWick Sealing Tape for the length of the metal saddle.
2. Piping systems 3" (75 mm) in diameter or less, insulated with fiberglass pipe insulation, may be supported by placing saddles of the proper length and spacing under the insulation as designated in Owens Corning Pub. 1-IN-14210.
3. For hot or cold piping systems larger than 3" (75 mm) in diameter, operating at temperatures less than +200F (93C) and insulated with fiberglass, inserts such as foam or high-density fiberglass with sufficient compressive strength shall be used to support the weight of the piping system.
4. On vertical runs, insulation support rings shall be used.

J. Accessories:

1. Insulation Bands: ¾ inch wide; 0.015 stainless steel
2. Metal Jacket Bands: ½ inch wide; 0.015 thick aluminum.
3. Insulating Cement: ANSI/ASTM C195; hydraulic setting mineral wool.
4. Finishing Cement: ASTM C449.
5. Fibrous Glass Cloth: Untreated; 8oz/sq. yd. Weight.
6. Adhesives: Compatible with insulation.
7. Wick material for wrapping valves and fittings
8. Closure Materials –Sealing Tape, and mastics.
9. Support Materials - Hanger straps, hanger rods, saddles, support high-density blocks, and support rings.
10. All accessory materials shall be installed in accordance with project drawings and specifications, manufacturer's instructions, and/or in conformance with the current edition of "Commercial & Industrial Insulation Standards."

2.17 PIPING / EQUIPMENT LOCATED IN AREAS SUBJECT TO FREEZING

- A. All piping subject to freezing shall be wrapped with heat trace cable, insulated as per specification and energy code, and in the case of drain piping, maintain a minimum continuous slope of 1%.
- B. Where ceiling mounted equipment penetrates into an uninsulated attic space, it shall be covered with blanket insulation meeting minimum building code requirements and done in a manner complying with the equipment manufacturer's recommendations.

2.18 FIRESTOPPING

- A. Provide Firestopping systems for penetrations in fire-resistance-rated assemblies, including both membrane and through penetrations. This contractor shall thoroughly review architectural plans for assembly type and location and shall prepare bid accordingly.
- B. Materials and systems shall be designed to meet the requirements of the intended application and shall be installed per manufacturer's guidelines.

- C. Submittals: Provide for review Manufacturer's product literature and tested assembly for each type of fire protection material including product characteristics, typical uses, installation procedures, performance and limitation criteria.

2.19 DRIP PANS & LEAK DETECTION

- A. Drip pans shall be provided where indicated on plans and under all new and existing piping within critical spaces.
- B. Drip pans shall be constructed of continuously welded sheet metal. Each section shall be provided with a wire type leak detection sensor compatible with fluids present in piping. Leak detection alarms shall be tied back to Building Management System.
- C. Provide new leak detection sensors in all existing drip pans. Tie alarms back to Building Management System.

2.20 SECONDARY DRAIN PANS

- A. A secondary drain pan shall be provided under each piece of concealed (above ceilings, in closets, etc.) HVAC equipped which produces condensate.
- B. The pan shall have a minimum depth of 1.5" and shall not be less than 3" larger than the unit or the coil dimensions in width and length and shall be constructed of corrosion resistant material. Metallic pans shall have a minimum thickness of not less than 0.0276-inch galvanized sheet metal and non-metallic pans shall have a minimum thickness of not less than 0.0625 inch.
- C. The secondary drain pan with a separate drain shall discharge to a conspicuous point of disposal to alert occupants in the event of a stoppage of the primary drain. The overflow drain line shall connect to the drain pan at a higher level than the primary drain connection.
- D. A secondary drain pan without a separate drain shall be equipped with water level detection device that will shut off the equipment served prior to overflow of the pan

PART 3: EXECUTION

3.1 OPERATING INSTRUCTIONS

- A. Instruction to the Owner's Personnel - After completion of all work and all tests and at such times as designated by the Architect, provide the necessary skilled personnel to operate the entire installation until receipt of owners acceptance.
- B. During the operating period, instruct the Owner's representative in the complete operation, adjustment, and maintenance of the entire installation.
- C. Give at least forty-eight (48) hours advance notice to the Owner to coordinate scheduling of this instructional period.
- D. Furnish to the Architect five (5) complete bound sets of typewritten or blueprinted instruction manuals for operating and maintaining all systems and equipment included in the contract. All instruction manuals shall be submitted in draft, for approval, prior to final issue. Manufacturer's advertising literature or catalogs will not be acceptable for operating and maintenance instructions.
- E. The above-mentioned instructions shall include the maintenance schedule for the principal items of equipment furnished under this contract.

3.2 MANUFACTURER'S RECOMMENDATIONS:

- A. Where installation procedures or any part thereof are required to be in accordance with the recommendations of the manufacturer of the material being installed, printed copies of these

recommendations shall be furnished to the Architect prior to installation. Installation of the item will not be allowed to proceed until the recommendations are received. Failure to furnish these recommendations can be cause for rejection of the material.

3.3 TESTING, ADJUSTING, STARTING UP AND COMMISSIONING

- A. Testing: All work must be proved satisfactory. The tests herein specified shall be applied in the presence of, and to the satisfaction of, the Architect before the work is covered, concealed or made inaccessible to testing, repair, correction or replacement. Accommodate the testing operation to the progress of the project as a whole. Correct all defects appearing under test and repeat the tests until all parts of the work have been successfully tested. Apply the specific tests herein described. Present all work for acceptance in clean condition, properly adjusted and in good working order; for instance, all machinery must be quiet, well balanced, and must be in place and reading accurately. All systems, equipment, controls, and devices in this work shall be tested in operation and must prove for their purposes in the judgment of the Architect or his authorized representative. All internal surfaces of all lines and equipment shall be blown or flushed clean. Where pressure tests are specified, the apparatus shall be clean before the tests are applied. Contractor shall provide adequate protection of piping and duct systems to prevent vandalism and/or accidental damage, blockage, etc., that will hinder or prevent proper operation of the finished systems.
1. Provide instruments, pumps, gauges, supplies, equipment, materials, and labor for testing and starting up. Dispose of test water and wastes after test, in a manner approved by all applicable codes.
 2. Perform tests which may be required by authorities or agencies in addition to those herein specified.
 3. Piping for steam, hot water, chilled water, supply and return, drain, escape and relief valve discharge shall be tested with water and made tight under pressure of 150 pounds per square inch gauge maintained for one hour without pumping or as long as required to inspect all joints. Repair all leaks and retest. Piping shall be made tight without caulking. Apply pressure tests to piping only before connection of equipment. In no case shall piping, equipment or accessories be subjected to a pressure exceeding it's rating. Low-pressure elements shall be isolated or removed before tests are conducted.
 4. Test valve bonnets for tightness. Test operate all valves at least once from closed-to-open-to-closed positions while valve is under pressure. Test all automatic valves for proper operation at the settings indicated. Test pressure relief valves at least three (3) times.
 5. Test piping specialties for proper operation. Test air vent points to ensure that air has been vented.
 6. Furnish certified shop test records for all pressure vessels. After installation, test at full operating pressures and temperatures maintained for one hour. Set and test all pressure control, relief and safety devices.
 7. Repair or replace all defective work and repeat tests until the particular system and component parts thereof receive the approval of the Architect.
 8. The duration of tests shall be as determined by authorities having jurisdiction, but in no case less than the time prescribed in each section of the specifications.
 9. Test equipment and systems, which normally operate during seasons of the year during the appropriate season. Perform tests on individual equipment, systems and their controls. Whenever the equipment or system under test is interrelated with and depends upon the operation of other equipment, systems and controls for proper operation, function, and performance; the latter shall be operated simultaneously with the equipment of system being tested.

B. Adjusting, Balancing and Starting Up

1. Flush clean all systems prior to starting up the system. Any damages to the building or system components caused by failure to clean the systems properly shall be corrected to the satisfaction of the Architect or his authorized representative at no additional cost to the Owner.
2. In duct and piping systems, eliminate all noise and vibration and take all measures to secure proper circulation.
3. Run motor-driven equipment continuously for at least two hours in the presence of the Architect. Correct all defects of noise, vibration, alignment and balance. Replace all motors, which overheat or are noisy.
4. Balance systems completely for temperature, volume, and pressure per NEBB performance standards. Balancing subcontractor shall provide proof of certification by NEBB.
5. Air and water volumetric flow rates shall be within ten (10) percent of those specified. Air and water quantities and pressures shall be tested, balanced and recorded at all terminal devices. Volumetric flows and pressures shall be recorded on suitable forms and submitted for approval.
6. Provide any and all labor and equipment necessary to properly balance the installation including but not limited to dampers, valves, flow stations, test ports, sheaves, belts, etc.
7. All sequences of the system shall be checked and all temperature controls operated and commissioned as required to insure that all systems operate per Engineers intent.

C. Commissioning

1. This Contractor shall provide the deliverables to the engineer/owner.
2. Copies of all records shall be provided to the Engineer by this Contractor including, but not limited to:
 - a) Equipment manuals including the name of at least one service agency;
 - b) Testing and Balancing reports;
 - c) Functional performance testing of the equipment, controls, economizers, and lighting control systems.
3. All commissioning shall be performed as indicated here and elsewhere in the specifications and shall comply with provisions of the applicable Energy Conservation Code.
4. Start-up shall be provided by factory representatives and a full start-up report shall be provided for review and approval for the following equipment:
 - a) Energy Recovery Units
 - b) Packaged Air Handling Units exceeding 20 Tons
 - c) Pumps exceeding 5 HP
 - d) Variable Refrigerant Flow (VRF) Systems

3.4 SEQUENCE OF OPERATIONS

- A. Sequence of Operations: This is a performance-based specification intended to convey the control intent of the various systems. The contractor shall provide detailed shop drawings including P&ID diagrams, equipment lists and finalized sequences for review by the Engineer

- prior to installation. Any questions concerning specific details shall be referred to the engineer for clarification.
- B. System: It is the intent of this specification that a complete Building Management System (BMS) utilizing Direct Digital Control (DDC) be provided to control and monitor all HVAC systems within the facility. Provide a single workstation for building maintenance personnel to interface with system sequences, setpoints and values.
- C. Variable Refrigerant Flow (VRF) systems shall be provided with a central factory controller which shall control and monitor all indoor and outdoor units associated with the VRF and ductless split systems. System shall allow for scheduling, set point limiting, and changing set points.
1. Provide additional sub controllers as required to accommodate the total number of pieces of associated equipment scheduled.
 2. System shall be web enabled to allow access through a networked PC, tablet, or other mobile device.
 3. Provide with BACnet communication card for full system monitoring and control through the BMS.
 4. Provide with Energy Allocation software to allow for the apportionment of electrical energy for each associated control zone.
- D. Equipment and Wiring: This contractor shall provide all control equipment, and wiring (regardless of voltage) to accomplish the sequence of operations as detailed below. This contractor shall carry funds sufficient to hire the Electrical Contractor to provide line-voltage power, including any required wiring, breakers, and/or disconnects, to all control's components needing such power. Such components shall include, but may not be limited to:
1. Control Transformers
 2. Central Equipment Controllers
 3. BMS Controllers
 4. BMS Head-end Equipment
 5. Line-voltage Thermostats or other sensors
- E. Control and Monitoring: Sensors shall be provided throughout the HVAC systems (hydronic and air) as required to control and monitor their operation and verify performance at BMS. Provide sensors with remote mounted stats where indicated on the drawings. Where multiple space mounted sensors are required for a given unit they shall be located in the same general area.
- F. Smoke Detection System and Control: Duct mounted smoke detectors (DSD) shall be installed as indicated on the plans and in the supply and return ductwork of all systems with a design capacity greater than 2000 CFM including the total airflow of common return air systems.
1. DSDs shall be installed at each story prior to the connection to a common return and prior to any recirculation or fresh air inlet connection in return air systems having a capacity greater than 15,000 CFM and serving more than one story.
 2. DSDs shall be installed in accordance with NFPA 72 and shall monitor the entire airflow conveyed by the system.
 3. Upon activation the smoke detectors shall shut down all operational capabilities of the air distribution system. Air distribution systems that are part of a smoke control system shall switch to the smoke control mode upon activation of a detector.
 4. DSDs shall be connected to a fire alarm system when present. The actuation of a

DSD shall activate a visible and audible supervisory signal at a constantly attended location. IN facilities that are required to be monitored by a supervising station, DSDs shall report only as a supervisory signal, not as a fire alarm.

- G. Safety Controls: This contractor shall provide all safety controls required to protect the building and all controlled equipment from damage as well as those controls necessary to signal abnormal operation or malfunction of equipment. These shall include but not be limited to high limits, low limits, freezestats, flow switches, interlocks and relays.
- H. Energy Efficiency: All controls and sequences shall be configured to provide maximum energy efficiency while maintaining occupant comfort.
- I. Functional Performance Testing: The contractor shall perform complete and thorough Control Functional Performance Test (FPT) and Commissioning of the control systems. Upon completion of the FPT, a report shall be submitted to the engineer for review and comment. The FPT shall include testing of:
 - 1. Safeties in every mode, i.e., in manual run mode as well as auto mode.
 - 2. Signals to and from the fire alarm, security and entry systems.
 - 3. Sequences of operation step by step in every mode and possible situation.
 - 4. The operation of all control loops under actual operating conditions.
 - 5. The interlocked operation of all equipment (i.e., the operation of starters in manual and off modes as well as auto mode, damper end switch interlock, etc.)
 - 6. Commissioning should test every conceivable life safety scenario and every conceivable operational scenario that the system will encounter and document this testing with printed graphs of trend logs.
- J. Building Management System
 - 1. System interface shall be web-based and accessible & adjustable from any web browser. System alarms and alerts shall be able to be programmed to be directed to a phone or email address.
 - 2. System shall monitor all associated equipment & points in real-time.
 - 3. System shall be capable of providing multiple occupancy schedules. Schedules shall be able to be programmed on a daily or monthly basis. Schedules shall allow for holidays. All schedules shall be able to be temporarily overridden at the request of the system operator through the web portal or at the space mounted user interface.
 - 4. The following points shall be monitored by the BMS:
 - a) Outside Air Temperature (DB/WB)
 - b) Outside Air Relative Humidity
 - c) Kitchen Temperature
 - d) Kitchen Supply Fan Status
 - e) Employee Lounge Temperature
 - f) Bag Storage Room Temperature
 - 5. The BMS shall provide alerts for the following:
 - a) Alarm/Trouble from any of the monitored systems
 - b) Hot water supply temperature out of range
 - c) Condenser water supply temperature out of range
 - d) Loss of motor function and/or flow (all monitored equipment)

6. System shall communicate using open protocols (e.g. BACnet, Lonworks). Controls contractor shall be responsible for ensuring all equipment is capable of effectively communicating with the BMS.
7. Refer to sequence of operations for additional information & requirements. All required fan & flow monitoring of belt drive systems shall be directly detected. Motor CTs shall not be accepted on belt drive equipment.
8. As a part of this contract, this contractor shall engage an electrical contractor to provide power and data wiring to all BMS controllers or other BMS system devices requiring the same.

K. Economizer Fault Detection and Diagnostics (FDD)

1. Air-cooled unitary direct-expansion units and variable refrigerant flow units equipped with an economizer shall include fault detection and diagnostics (FDD) complying with the following:
 - a) The following temperature or enthalpy sensors shall be permanently installed to monitor system operation:
 - (i) Outside Air
 - (ii) Supply Air
 - (iii) Return Air
 - b) Temperature sensors shall have an accuracy of $\pm 2^{\circ}\text{F}$ over its range.
 - c) Refrigerant pressure sensors, where used, shall have an accuracy of $\pm 3\%$ of full scale.
 - d) The unit controller shall be capable of providing system status by indicating the following:
 - (i) Free cooling available
 - (ii) Economizer enabled
 - (iii) Compressor enabled
 - (iv) Heating enabled
 - (v) Mixed air low limit cycle active
 - (vi) The current value of each sensor
 - e) The unit controller shall be capable of manually initiating each operating mode so the operation of compressors, economizers, fans and the heating system can be independently tested and verified.
 - f) The unit shall be capable of reporting faults to the BMS (where applicable) or annunciated locally at the unit thermostat.
 - g) The FDD system shall be capable of detecting the following faults:
 - (i) Air temperature sensor failure/fault
 - (ii) Not economizing when the unit should be economizing
 - (iii) Economizing when the unit should be not economizing
 - (iv) Damper not modulating
 - (v) Excess outdoor air

L. Kitchen Exhaust and Make-Up Air Unit Control:

1. Exhaust fan and Make-Up Air Unit shall be switched from the control panel on the

kitchen hood and interlocked to operate in conjunction with one another. Make up Air unit Discharge air thermostat shall fire the gas furnace to maintain a constant discharge temperature (adj.).

2. Upon activation of Hood fire protection system, the make up air unit shall be de-energized and the associated exhaust fan shall remain active.
3. Kitchen exhaust fans & make-up air unit shall be provided with variable speed energy management control. Fan speeds shall be adjusted based on exhaust temperature.

M. Kitchen Exhaust (PCU) and Make Up Air Unit (MAU) Control:

1. PCU and MAU shall be furnished by others and installed by this contractor. Responsibility for full control of systems, including provision of the central kitchen ventilation control panel, to provide intended sequence is the responsibility of this contractor. All work shall be performed in coordination with the electrical, plumbing and fire alarm contractors.
2. Hood Lighting: Hood lighting shall be energized from control panel.
3. PCU: Upon initiation at the control panel the PCU shall be energized. The PCU shall be provided with an individual Ansul System piped throughout the unit and tied back to Main Control Panel.
4. MAU: Make Up Air unit shall be interlocked to operate with the PCU system. Discharge air thermostat shall modulate the gas furnace to maintain a constant discharge temperature (60 deg F adj.).
5. Ansul System (Hood and/or PCU):
 - a) Upon activation of Hood fire protection system, the control panel shall initiate the following:
 - (i) The makeup air unit shall be de-energized.
 - (ii) The associated pollution control system exhaust fan shall remain active.
 - (iii) The natural gas control valves shall be closed.
 - (iv) Shunt trip for electrical equipment shall be engaged.
 - (v) The fire alarm system will be triggered into alarm condition.

N. Variable Refrigerant Volume (VRV) System:

1. General: System shall be capable of providing simultaneous heating & cooling.
2. VRV Heat Pump (outdoor unit): Unit shall fully modulate its refrigerant flow and condenser fan speed in order to match the heat rejection requirements of the system.
3. BC Controller: Unit shall deliver refrigerant to each terminal unit based on individual units heating or cooling requirements.
4. Terminal Unit (FC):
 - a) Occupied: Fan shall run continuously. Unit shall cycle its refrigerant flow to maintain the space temperature as sensed by the space mounted temperature sensor.
 - b) Unoccupied: Fan shall be de-energized. On a call for heating or cooling from the space mounted temperature sensor the unit shall cycle its refrigerant flow to maintain the space temperature. When the sensor is satisfied the unit shall de-energize.

O. Energy Recovery Ventilator (ERV):

1. Occupied: Supply & exhaust fans shall run continuously in the occupied mode.

2. Unoccupied: Supply and exhaust fans shall be de-energized in the unoccupied mode.

P. Air Handling Unit Control:

1. Occupied winter: Supply and interlocked exhaust fans (where applicable) shall run continuously. Thermostat shall modulate heating valve steps in sequence to maintain the set point. Coil shall be allowed to energized only when air flow is proven. Outside air damper shall open to allow minimum outside air flow.
2. Unoccupied winter: Upon a drop in space temperature below the night setback temperature, the supply fan and heating valve shall be cycled to maintain temperature. Outside air damper shall be closed.
3. Occupied summer: Supply and interlocked exhaust fans (where applicable) shall run continuously. The cooling coil shall modulate as required to maintain space temperature setting. The heating coil shall be de-energized. Outside air damper shall open to allow minimum outside air flow.
4. Unoccupied summer: Supply and exhaust air fans shall be de-energized. Outside air damper shall be closed.
5. Economizer & Differential Enthalpy Economizer Control: When the outside air is suitable for cooling, the outside air damper and interlocked exhaust fan shall modulate to increase the percentage of outside air, up to 100% to satisfy cooling load. In addition, when the enthalpy of the outside air is less than that of the return air, differential enthalpy economizer operation shall be initiated allowing mechanical cooling in conjunction with economizer operation.
6. VFD (Variable Frequency Drive): A duct mounted static controller and transmitter, located 2/3 down the duct or where shown on the drawings, shall send signal to VFD to maintain the supply duct setpoint (set point .5 adjustable).
7. Safety Controls: Provide the following:
 - a) Low limit controller: stop fan, open heating coil valve, close outside air damper, if temperature should fall to 45 degree (adjustable). Locate controller/sensor in discharge duct. DDC reset required.
 - b) High Limit Controller: Stop fan, open heating coil valve, close outside air damper, if temperature shall rise above 110 degree (adjustable). Locate controller/sensor in discharge duct. DDC reset required.
 - c) Freezestat Controller: Stop fan, open heating coil valve, close outside air damper, if temperature should fall to 38 degree (adjustable). Locate controller / sensor between heating coil and cooling coil. Serpentine across discharge face and heating coil. DDC reset required.
 - d) Static Pressure High Limit Controller: (Supply fan) stop fan, open outside air damper, close heating coil valve. Locate in discharge duct. DDC reset required.
 - e) Supply and exhaust fan status, discharge and outside air temperature shall be indicated at the console.

Q. Exhaust Fans:

1. Bathroom/Janitor Closet Ceiling Exhaust Fans
 - a) Fan power shall be interlocked with lighting circuit.
2. Ceiling Exhaust Fans (Electrical Room)
 - a) Upon deactivation of boost mode (via drop in humidity, lack of occupancy or deactivation of boost switch) the fan shall cycle to low speed after the pre-determined time delay period (15 min. adj.).

- R. Electric Heater Control: (cabinet type, unit type, baseboard type, etc.)
 - 1. Provide single temperature unit or room mounted thermostat to cycle electric heating coil and fan motor to maintain constant space temperature.
- S. Ductless Split System A/C
 - 1. Cooling: In the cooling mode, the supply fan shall run and the refrigeration circuit shall be energized and cycle to maintain the cooling setpoint of the space/unit mounted temperature sensor. When the cooling setpoint is reached, the reverse shall occur.
 - 2. Heating: In the heating mode, the supply fan shall run and the electric heat shall energize to maintain the heating setpoint of the space/unit mounted temperature sensor. When the heating setpoint is reached, the reverse shall occur.
 - 3. Dehumidification: Upon sensing a rise in humidity, the cooling circuit shall energize and the electric heat shall cycle to maintain space temperature.
 - 4. Provide low ambient controls.
- T. Split Heat Pump Control
 - 1. Unit shall run on its factory programmed control sequence.
 - 2. On a call from the space mounted thermostat, the unit shall cycle its fan, compressor and reversing valve as required to maintain space temperature setpoint. Upon thermostat being satisfied the reverse shall occur.
 - 3. Scheduling shall be set at the central controller and be capable of being temporarily overridden by the space mounted controllers.
- U. Overflow cut-off switches:
 - 1. Provide an overflow cut-off switch in each secondary drain pan to shut down the associated unit and provide an alarm prior to overflow.
- V. Fire/Smoke Dampers:
 - 1. Fire/Smoke Dampers shall close upon detection of smoke and be tied into building fire alarm system.
- W. Gas Detection System
 - 1. Control Panel
 - a) The control panel shall provide continuous monitoring of the designated gas levels in the assigned area and control the ventilation system via digital outputs in accordance with all applicable codes and standards.
 - b) The control panel shall have the ability to interface with the building management system via as applicable:
 - (i) Analog or digital outputs to any compatible electronic analog control, DDC/PLC control or automation system.
 - (ii) Upward communication via BACnet communication protocol to any compatible electronic control, DDC/PLC control or automation system.
 - c) The control panel shall have the capability to accept any combination of 4-20 mA transmitters provided by INTEC Controls (a Relevant Solutions brand).
 - d) The control panel shall accept up to twenty (20x) analog inputs with four (4) digital inputs. Each analog input can have five (5) trip/set-points.
 - e) There shall be five (5) relay outputs for every four (4) analog inputs and two

(2) independent 4-20 mA outputs available. The outputs shall be programmable in the field. Each of the sensing points is readily addressable to either of the (2) analog outputs by selecting the Minimum, Maximum, or Average value.

- f) The alarm shall be acknowledged by an external manual reset switch via the digital input or through the control panel menu.
- g) The control panel shall have status indicator LED's located on the front; Red = Fail, Yellow = Alarm.
- h) The control panel shall include a two line, backlit LCD display of 16 characters, at 1 digit resolution.
- i) The controller shall be NRTL performance tested and certified to ANSI/UL 2017.
- j) The contractor shall supply the PolyGard® Series MGC2-20 analog controller, by INTEC Controls or approved equal.
- k) Provide quantities as indicated on the plans.

2. Carbon Monoxide (CO) Sensor/Transmitter

- a) The carbon monoxide sensor/transmitter shall provide monitoring of the carbon monoxide levels in the parking garage and control the ventilation system via the control panel in accordance with all applicable codes and standards.
- b) The sensors shall be electrochemical type. The sensor/transmitter shall have plug-in technology for ease of troubleshooting and replacement of both the element and the printed circuit board. Solid-state sensing devices shall not be acceptable.
- c) The sensor range shall be 0-250 ppm carbon monoxide. A microprocessor-based transmitter shall generate a proportional 4-20 mA output signal. The wiring between the transmitter and the control panel shall be a 2-wire, twisted and shielded, 4-20mA, 17-28 VDC configuration. Each sensor/transmitter shall cover between 5,000 and 10,000 square feet of the garage floor and placement shall be applied strategically and appropriately per floor plan requirement.
- d) The sensor shall have stability and resolution of ± 3 PPM of reading, repeatability of $\pm 3\%$ of reading, and a response time of 50 seconds to a 90% step change. The long-term output drift shall not exceed more than 0.4% of signal loss per month. The permissible ambient working temperature shall be 14°F to 122°F (-10°C to 50°C) and permissible ambient humidity shall be 15 to 95% RH, non-condensing. The sensor shall require no routine maintenance other than periodic calibration. Its life expectancy shall be 5 years of normal service. The manufacturer shall provide a two 2-year warranty for materials and workmanship, and a 12-month warranty on the sensing element under normal exposure.
- e) The sensor/transmitter printed circuit board shall have the capability of adding up to (2) alarm relays with individual setpoints for local control or status indication.
- f) The sensor/transmitter shall be contained in a NEMA 4X metal enclosure. The enclosure for the sensor/transmitter shall be installed on walls or columns approximately 5 feet above the floor.
- g) The output signal from the sensor/transmitter shall be a direct input to the

control panel. All sequences of fan and alarm control, including time delay functions to prevent hunting of ventilation fans shall be a part of the control panel.

- h) If the level of Carbon Monoxide reaches 25 PPM in the area of detection, the low alarm shall activate and the exhaust fans will be started. If the level of CO increases to 100 PPM, the high alarm shall activate.
- i) The sensor/transmitter shall be NRTL performance tested and certified to ANSI/UL 2075.
- j) The contractor shall supply the PolyGard® Series LC-1112 CO sensor/transmitter, by INTEC Controls or approved equal.
- k) Quantities & locations indicated on the plans shall be verified by the sensor manufacturer prior to procurement.

X. VRF Refrigerant Leak Detectors

- 1. Provide a mounted stationary refrigerant gas leak sensor to alarm at specified level of refrigerant gas in the area where refrigerant gas is most likely to accumulate. The unit shall be recessed in the wall in a standard 2-gang electrical box. self-contained with sensing element, alarm horn and relay contacts.
- 2. The local alarm shall be activated within the occupied space once the detected refrigerant level exceeds the threshold. The alarm shall provide an audible horn at 83dB at 10 feet and visual LED indication.
- 3. The unit shall meet the following:
 - a) Non-Dispersive Infrared sensing element for R410A refrigerant.
 - b) Communications: Two SPDT (Form C) dry relay contacts 1.0A max at 24 VDC, Modbus RTU, RS485 transmission standard.
 - c) Multicolored LED status indication: Green Blinking / Warm-up, Green Fixed / Normal status, Yellow / Fault, Red Blinking / Alarm.
- 4. Monitor shall be the SensAC VRF leak detector by Unlimited Controls or approved equal.

END OF SECTION

THIS PAGE INTENTIONALLY LEFT BLANK

SECTION 260000

ELECTRICAL

PART 1 – GENERAL

1.1 RELATED SECTIONS

- A. Drawings and General Provisions of Contract, including General and Supplementary Conditions and Division 1 Specification Sections, apply to work of this section.
- B. This Contractor shall also include allowances for startup and for making the systems fully operational, and for scope and design contingencies. Future changes in price for items not shown on these drawings will not be allowed if the system itself is shown on these Drawings.
- C. Give notices, file plans, obtain permits and licenses, pay fees and back charges, and obtain necessary approvals from authorities that have jurisdiction as required to perform work in accordance with all legal requirements and with Specifications, Drawings, Addenda and Change Orders, all of which are part of Contract Documents.
- D. The drawings show the layout of the electrical systems and indicate the approximate locations of outlets, apparatus, and equipment. The runs of feeders and branches as shown on the drawings are schematic only. The exact routing of branch circuits and feeders shall be determined by the structural conditions and possible obstructions. This shall not be construed to mean that the design of the systems may be changed but refers only to exact runs between given points. The Engineer reserves the right to revise the drawings from time to time to indicate changes in the work.
- E. The Contractor shall consult and review all contract and reference drawings which may affect the location of any outlets, apparatus and equipment to avoid any possible interference and permit full location of outlets, apparatus and equipment up to the time of rough-in is reserved by the Engineer and such change shall be made without additional expense to the Owner.
- F. It shall be the responsibility of this Contractor to see that all electrical equipment such as junction and pull boxes, panelboards switches, controls and such other apparatus as may require maintenance and operation from time to time is made accessible. Although the equipment may be shown on the drawings in certain locations, the construction may disclose the fact that such locations do make its position accessible. In such cases this Contractor shall call the attention of the Engineer to the condition before advancing the construction to a state where a change will reflect additional expense to the Owner.

1.2 SUMMARY

- A. This Section specifies the basic requirements for electrical installations and includes requirements common to more than one section of Division 26. It expands and supplements the requirements specified in sections of Division 1.
- B. These documents have been prepared with the intention that they call for finished, tested work, in full operating condition and complete with necessary accessories.
- C. The contract drawings are generally diagrammatic and convey the scope of work and general arrangement of apparatus and equipment. The locations of all items shown on the drawings or called for in the specifications that are not definitely fixed by dimensions are approximate only. The exact locations necessary to secure the best conditions and results must be determined at the project and shall have the approval of the Architect/Engineer before being installed. The Contractor shall follow the drawings in laying out work and shall check drawings of the other trades to verify spaces in which work will be installed. Maintain maximum headroom and space conditions at all points. If directed by the General Contractor, Engineer and/or Architect, the Contractor shall, without extra charge, make reasonable modifications in the layout as needed to prevent conflict with work of other trades or for proper execution of the work.
- D. These contract documents are complementary. What is called for by one shall be as binding as if called for by all. Materials or work described in words which have well-known technical, or trade meaning shall be held to refer to such recognized standards. Incidental devices and accessories needed for

complete, operational systems shall be provided even though they may not be indicated or identified in the documents.

- E. If apparatus has been omitted, notify the Architects/Engineers of such belief. It is understood that bidder has included all required items and work in his bid, and will not if bid is successful, claim extra compensation for furnishing a complete and satisfactory system. If a particular item is called for or specified more than once in these contract documents, the higher grade shall be considered specified.
- F. Should it appear that the character of the work is not sufficiently explained in these specifications or on the drawings, apply to the A/E for further information. Conform to the A/E's decision and directions as shall become part of these contract documents. The A/E reserves the right to be sole interpreter of the drawings and specifications, and all decisions shall be conclusive, final and binding on the parties.
- G. Materials called for in these documents shall be new, unused equipment and of the latest recognized standards.
- H. The work to be done under Division 26 is shown on the electrical drawings.

1.3 OUTLINE SCOPE OF WORK

- A. The work under this contract, without limiting the generality thereof, includes all materials, labor, equipment, services, and transportation, unless otherwise specified, necessary to complete all systems of electrical wiring and equipment required by the drawings and/or as specified herein. It is the intent of this section and accompanying electrical drawings that these systems be furnished complete in every respect. The Electrical Contractor shall furnish all wiring, equipment and labor needed for a complete operating installation.
- B. The Electrical Contractor shall fully indemnify the Owner against any damages, removals and alteration work. This is in addition to the requirements of the General Conditions of the Specifications.
- C. The Electrical Contractor shall review architectural, interior design and all other trades plans, elevations and details prior to any work and identify any conflicts between furnishings, furniture, art-work, molding, casework, televisions, signage, awnings, canopies, diffusers, fixtures, etc.. and electrical, fire alarm, audio/visual and communications devices shown on the electrical plans and details. The Electrical Contractor shall prepare 8.5" x 11" sketches showing the conflicts and submit to the Architect for resolution prior to any work. Failure of the electrical contractor to coordinate, identify and obtain a field-directive on any conflict herein noted, that results in installed electrical work to be relocated to the Owner/Architects liking shall be the sole-responsibility of the Electrical Contractor. The Electrical Contractor shall assume and cover all costs associated with conflicts not coordinated, identified and submitted to the Architect, inclusive of material, labor, overtime pay, etc.. and shall not affect the project schedule.

1.4 ROUGH-IN

- A. Verify final locations for rough-ins with field measurements and with the requirements of the actual equipment to be connected.
- B. Refer to equipment specifications in Divisions 2 through 25 for rough-in requirements.

1.5 SURVEYS AND MEASUREMENTS

- A. Base measurements, both horizontal and vertical, on established bench marks. Work shall agree with these established lines and levels. Verify measurements at site and check the corrections of same as related to the work.
- B. Should the Contractor discover any discrepancy between actual measurements and those indicated, which prevents following good practice or the intent of the drawings and specifications, he shall notify the A/E.

1.6 EXAMINATION OF SITE

- A. Prior to submitting bid, visit the site where the work is to be performed and the materials are to be delivered. Failure in this respect shall not excuse the Contractor from his obligation to supply and install the work in accordance with the plans and specifications and under all conditions, as they exist.
- B. By submitting a bid, this Contractor warrants that all specification sections and drawings showing equipment for plumbing, heating, ventilation, air conditioning, electrical, and architectural, have been examined and is familiar with the conditions and extent of work affecting this contract.

1.7 EQUIPMENT AND MATERIALS

- A. All equipment and materials for permanent installation shall be the products of recognized manufacturer's and shall be new, unless noted for re-use, without damaged, functional or aesthetic components.
- B. New equipment and materials shall:
 - 1. Be Underwriters Laboratories, Inc. (UL) labeled and/or listed where specifically called for, or where normally subject to such UL labeling and/or listing services
 - 2. Be without blemish or defect.
 - 3. Be in accordance with the latest applicable NEMA standards.
 - 4. Be products, which will meet with the acceptance of the agency inspecting the electrical work. Where such acceptance is contingent upon having the products examined, tested and certified by UL or other recognized testing laboratory, the product shall be so examined, tested and certified.
- C. For all equipment, which is to be installed but not purchased as part of the electrical work, the electrical work shall include:
 - 1. The coordination of their delivery.
 - 2. Their unloading from delivery trucks driven in to any point on the property line at grade level.
 - 3. Their safe handling and field storage up to the time of permanent placement in the project.
 - 4. The correction of any damage, defacement or corrosion to which they may have been subjected.
 - 5. Their field make-up and internal wiring as may be necessary for their proper operation.
 - 6. Their mounting in place, including the purchase and installation of all dunnage, supporting members and fastenings necessary to adapt them to architectural and structural conditions.
- D. Equipment, which is to be installed but not purchased as part of the electrical work, shall be carefully examined upon delivery to the project. Claims that any of these items have been received in such condition that their installation will require procedures beyond the reasonable scope of the electric work will be considered only if presented in writing within one week of the date of delivery to the project of the items in question. The electric work includes all procedures, regardless of how extensive, necessary to put into satisfactory operation, all items for which no claims have been submitted as outlined above.

1.8 ELECTRICAL INSTALLATIONS

- A. All materials and labor called for, specified in Division 26 of the specifications, and or shown on the electrical drawings furnished under this contract shall be provided under Division 16 unless called for otherwise in the Division 16 documents. The word "provide" as used in the Division 16 documents, shall mean to furnish, install, connect up, complete with all accessories ready for operation and warranted.
- B. Coordinate electrical equipment and materials installation with other building components. Fully coordinate work with that of other trades. Furnish information in writing that is needed for the coordination of clearances, etc., with the work of others, and such information shall be given in a timely fashion so as not to impede the progress of two or more trades. Confer and resolve the conflict immediately. If so directed by the A/E, prepare composite drawings to resolve any space or clearance conflict.
- C. Verify all dimensions by field measurements.
- D. Arrange for chases, slots, and openings in other building components to allow for electrical installations.
- E. Coordinate the installation of required supporting devices and sleeves to be set in poured in place concrete and other structural components, as they are constructed.

- F. Sequence, coordinate, and integrate installations of electrical materials and equipment for efficient flow of the Work. Give particular attention to large equipment requiring positioning prior to closing-in the building.
- G. Coordinate the cutting and patching of building components to accommodate the installation of electrical equipment and materials.
- H. Where mounting heights are not detailed or dimensioned, the exact location shall be determined by the A/E, install electrical services and overhead equipment to provide the code and/or utility requirements.
- I. Install electrical equipment to facilitate maintenance and repair or replacement of equipment components. As much as practical, connect equipment for ease of disconnecting, with minimum of interference with other installations.
- J. Coordinate the installation of electrical materials and equipment above ceilings with suspension systems, mechanical equipment and systems, and structural components.
- K. Coordinate connection of electrical systems with exterior underground and overhead utilities and services. Comply with requirements of governing regulations, franchised service companies, and controlling agencies. Provide required connection for each service.
- L. Attention is directed to areas and items indicated on the drawings by the notations "HOLD", "N.I.C.", "BY OTHERS" and words of similar intent. The work indicated in these areas is shown for information and continuity only. Work or items furnished and installed in these areas solely for the convenience of this Contractor or others, without prior written approval of the Owner, shall be removed at the option of the Owner and at the Contractor's expense.
- M. Provide all required staging and scaffolding for all the work under this section.

1.9 ALTERATION WORK

- A. Maintain continuity of service in areas where occupancy is to be maintained during alterations. If it becomes necessary to disconnect or interrupt service, obtain written consent of the Owner, and only disconnect service at the convenience of, and with the consent of the Owner. A copy of the written request for a shutdown shall be forwarded to the A/E.

1.10 CUTTING AND PATCHING

- A. Cutting and patching of electrical equipment, components, and materials specified under Division 26 (conduit, sleeves, equipment, etc.) shall be performed by Electrical Contractor.
- B. Refer to the Conditions of the Contract (General and Supplementary) and Division 1 Section: "Cutting and Patching" for definitions, requirements, and procedures.
- C. Cutting and patching of existing structures (thru walls, floors, ceilings, etc.) to accommodate equipment, components, and materials of all Contractors, including Mechanical and Electrical Contractors, shall be performed by General Contractor and/or his designated Subcontractor.
- D. Cutting and patching of new structures (thru walls, floors, ceilings, etc.) to accommodate installation of ill-timed work or removal and replacement of defective work or work not conforming to requirements of Contract Documents, shall be performed by General Contractor and/or his designated Subcontractor and costs shall be back charged to appropriate trade Contractor.
- E. Do not endanger or damage installed work through procedures and processes of cutting and patching.
- F. Arrange for repairs required to restore other work, because of damage caused as a result of electrical installations.
- G. Arrange to have ducts, raceways, conduit, panelboards, boxes, and such other pertinent parts, set in place ahead of construction work so that they will be built-in with structures and eliminate need for cutting and patching. Failure to conform to this paragraph will require that this Contractor perform any cutting and patching required for his work at his expense. Cutting shall be neatly finished to match adjoining work in a manner acceptable to the A/E. Cutting and patching shall not affect the fire rating of walls or structural parts. Cutting and patching required to correct work, due to error or negligence of the Contractor, or to defects in his material or workmanship, shall be corrected at no additional cost to the Owner. Patching shall meet or exceed quality of adjacent surfaces. Cutting must be accomplished as not to weaken adjacent structural members and must be approved by the Structural Engineer before proceeding.

- H. Perform cutting, fitting, and patching of electrical equipment and material required to:
 - 1. Uncover work to provide for installation of ill-timed work.
 - 2. Remove and replace defective work.
 - 3. Remove and replace work not conforming to requirements of the contract documents.
 - 4. Remove samples of installed work as specified for testing.
 - 5. Install equipment and materials in existing structures.
 - 6. Upon written instructions from the A/E, uncover and restore work to provide for A/E observation of concealed work.
- I. Cut, remove and legally dispose of selected electrical equipment, components and materials as indicated, including, but not limited to, removal of electrical items indicated to be removed and items made obsolete by the work.
- J. Protect the structure, furnishing, finishes, and adjacent materials not indicated or scheduled to be removed. Protect the electrical work and the work of others in a manner best suited to the particular case. Correct any damage done to any work at no additional cost.
- K. Provide and maintain temporary partitions or dust barriers adequate to prevent the spread of dust and dirt to adjacent areas.
- L. Locate, identify, and protect electrical services passing through areas that are to under-go remodeling or demolition. Electrical services serving other areas required to be maintained, and transit services must be interrupted, provide temporary services for the affected areas and notify the Owner prior to changeover.

1.11 SUBMITTALS

- A. Within fifteen (15) business days after the date of notice to proceed and before purchasing any materials or equipment, submit for approval a complete list, in six (6) copies, of all materials to be incorporated in the work.
- B. Shop drawings/manufacturer's cuts are required for:
 - 1. Wire & Cable.
 - 2. Lighting Fixtures.
 - 3. Panelboards.
 - 4. Disconnect Switches.
 - 5. Wiring Devices and Plates.
 - 6. Fire Alarm System.
 - 7. Generator System.
 - 8. Fire Stopping Materials.
 - 9. Seismic Restraint Components.
- C. After the list has been processed, submit complete shop drawings of all equipment. These shop drawings submittals shall be submitted within thirty days after the processing date of the original submittal.
- D. All submittals shall be complete and submitted electronically to all applicable parties. No consideration will be given to partial submittals except with prior approval. No consideration will be given to faxed submittals.
- E. Explanation of Shop Drawing Stamp:
 - 1. Approved: indicates that we have not found any reason why this item should not be acceptable within the intent of the documents.
 - 2. Approved with Comments: indicates that we have found questionable components which, if corrected or otherwise explained, make the product acceptable.
 - 3. Resubmit for Final Review: indicates that this item should be resubmitted for approval before further processing.
 - 4. Does Not Conform: indicates that the item will not meet the intent of the Contract.
- F. No shop drawing stamp or note shall constitute an order to fabricate or ship. Such notification can only be performed by the Project Manager for construction, the Contractor scheduling his own work, or the Owner.
- G. Submittal of shop drawings, product data, will be reviewed only when submitted by the Contractor. Data submitted from Sub-contractors and material suppliers directly to the A/E will not be processed.

- H. If shop drawing is not in compliance after two submissions, a third submission for the same manufacturer will not be considered for review.
- I. Check shop drawings and other submittals to assure compliance with contract documents before submittal to A/E.
- J. Review of shop drawings is final and no further changes shall be considered without written application. Shop drawing review does not apply to quantities, dimensions, nor relieve this Contractor of his responsibility for furnishing materials or performing his work in full compliance with these contract drawings and specifications. Review of these shop drawings shall not be considered a guarantee of the measurements of this building or the conditions encountered.
- K. General requirements for the substitution of equipment and submittal of shop drawings as follows. If apparatus, systems or materials are substituted for those specified, and such substitution necessitates changes in, or additional connections, wiring, supports, or construction, it shall be provided by this Contractor at no additional cost to the Owner. This Contractor shall assume all cost and entire responsibility thereof. The approval of substituted equipment does not relieve the contractor of his/her responsibility of shop drawing errors related to details, sizes, quantities, wiring diagram arrangements and dimensions which deviate from the Specifications, and/or job conditions as they exist. It is the contractor's responsibility to submit only those items that meet the specified apparatus, systems and material. Should any non-conformance code items be installed, they shall be replaced by this Contractor at no additional cost to the Owner. The construction means and methods used in the project shall be reviewed and approved through the local building department or a deputy inspector to insure compliance with the current codes, project specifications and general building practices.
- L. Coordination drawings shall be submitted and shall show all HVAC, Electrical, Plumbing and Fire Protection systems superimposed in order to identify conflicts and ensure inter-coordination of all trades. Coordination drawings shall be initiated under this Section of the Specifications. It is this Contractors responsibility for preparation of project coordination drawings showing the installation of all electrical equipment, switchgear, motor control centers, panelboards, transformers, transfer switches, disconnect switches, enclosed circuit breakers, conduits, outlets, switches and accessories to be provided under this Section of the Specifications. These drawings shall be prepared at not less than 3/8 in. = 1 ft. scale, and shall show building room layouts, structural elements, ductwork and lighting layouts of function. A reproducible copy of each drawing prepared shall then be submitted to the Mechanical, Plumbing and Sprinkler Contractors, who shall be responsible to coordinate his equipment and systems and shall show these on the drawings submitted. After this Contractor has fulfilled his obligation, he shall notify all other Contractors. After each drawing has been coordinated between trades, each trade shall sign each drawing, indicating acceptance of the installation. This Contractor shall then print the coordination original and these prints submitted through the General Contractor to the architect for review and comment, similar to shop drawings. Comments made on these drawings shall result in a correction and re-submittal of the drawings. A Subcontractor who fails to promptly review and incorporate his work on the drawings shall assume full responsibility of any installation conflicts affecting his work and of any schedule ramifications. Review of coordination drawings shall not diminish responsibility under this Contract for final coordination of installation and maintenance clearances of all systems and equipment with Architectural, Structural, Mechanical, and Electrical Contractors.

1.12 PRODUCT OPTIONS AND SUBSTITUTIONS

- A. Refer to the Conditions of the Contract (General and Supplementary) and Division 1 for definitions, requirements, and procedures.
- B. If materials of equipment are substituted for specified items that alter the systems shown or its physical characteristics, or which have different operating characteristics, clearly note the alterations or differences and call it to the attention of the A/E. Under no circumstances shall substitutions be made unless identical material or equipment has been successfully operated for at least three consecutive years.
- C. All substitution made by the Contractor shall require the Contractor to fully coordinate the substitution with other trades. The Contractor must make any modifications required by the substitution at no additional cost to the Owner. In addition the Contractor must notify the A/E of any changes required

and obtain approval for the changes. The review of the shop drawings by the A/E shall not relieve the Contractor from his responsibility as set forth in this specification.

1.13 NAMEPLATE DATA

- A. Provide permanent operational data nameplate on each item of power operated equipment, conduits with pull string, indicating manufacturer, product name, model number, serial number, capacity, operating and power characteristics, labels of tested compliances, and similar essential data. Locate nameplates in a readily accessible location.

1.14 DELIVERY STORAGE AND HANDLING

- A. Deliver products to project properly identified with names, model numbers, types, grades, compliance labels, and similar information needed for distinct identifications; adequately packaged and protected to prevent damage during shipment, storage, and handling.
- B. Store equipment and materials at the site, unless off-site storage is authorized in writing. Protect stored equipment and materials from damage. All devices shall be stored in a locked room. Assume responsibility for the devices until the date of final inspection.
- C. Coordinate deliveries of electrical materials and equipment to minimize construction site congestion. Limit each shipment of materials and equipment to the items and quantities needed for the smooth and efficient flow of installations.

1.15 RECORD DOCUMENTS

- A. As work progresses and for the duration of Contract, maintain a complete and separate set of prints of Contract Drawings at job site at all times. Record work completed and all changes from original Contract Drawings clearly and accurately including work installed as a modification or addition to the original design. Work shall be updated on a weekly basis and shall be made available for review by Architect. Failure to perform this work shall be reason for withholding requisition payments. In addition, take photographs of all concealed equipment in gypsum board ceilings, shafts, and other concealed, inaccessible work. At completion of work, make copies of photographs with written explanation on back. These shall become part of Record Documents.
- B. At completion of work prepare a complete set of Record As-Built Drawings in AutoCAD, Computer Aided Drafting (CAD) software, showing all systems as actually installed, including all fire alarm and electrical circuitry. The Record As-Built Drawings computer files shall be made available to the Architect, Engineer and Owner prior to final payment.
- C. The Architect will not certify the accuracy of the Record Drawings. This is the sole responsibility of the Electrical Contractor.
- D. This trade shall submit the record set for approval by the Fire and Building Departments in a form acceptable to the departments, when required by the jurisdiction.
- E. Drawings shall show record condition of details, sections, riser diagrams, control changes and corrections to schedules. Schedules shall show actual manufacturer and make and model numbers of final equipment installation.

1.16 WARRANTIES

- A. Refer to the Conditions of the Contract (General and Supplementary) and Division 1 for definitions, requirements, and procedures.
- B. All work and equipment furnished under this Section shall be guaranteed free from defects in workmanship or materials for a period of one (1) year, unless specifically noted otherwise for a particular system, from the date of final acceptance of the systems as set forth in this Contract. The Subcontractor shall replace any defective work developing during this period, unless such defects are clearly the result of misuse of equipment by persons not under the control of the Subcontractor, without cost to the Owner. Where such defective work results in damage to work of other Sections, all such

work shall be restored to its original condition by mechanics skilled in the affected trade, at the expense of the Subcontractor. The Subcontractor shall submit a separate written guarantee stipulating the aforesaid conditions.

- C. Prior to or at the time of Substantial Completion for the work and during administrative close-out of the project, submit one (1) copy of all specified warranties and guarantees to the Architect for review, approval and subsequent transmittal to the Owner.
- D. Warranties and guarantees, including those specified in excess of the general one (1) year guarantee, shall be complete for all specific materials, systems, sub-systems, equipment, appliances and products specified and required by the Contract Document.
- E. Warranties and guarantees shall clearly define what is to be guaranteed; the extent, terms, conditions, time and effective dates.
- F. Copies of the same warranties and guarantees shall be included in the "Operating and Maintenance Manual" as specified herein.

1.17 CLEANING

- A. Refer to the Conditions of the Contract (General and Supplementary) and Division 1 for definitions, requirements, and procedures.
- B. Upon completion of work, the Contractor shall clean, polish and leave bright, fixtures and lamps, and shall remove dust, dirt, debris and loose plaster from panelboards, controls, and switchboards. Unused openings in pull boxes, junction boxes, equipment and raceways shall be capped or closed by an approved means. Replace all inoperative lamps.

1.18 DEFINITION OF TERMS

- A. "This Contractor" or "E.C." specifically means, the Electrical Contractor working under this section of the specifications.
- B. "Concealed" means hidden, in chases, furred spaces, walls, above ceilings or enclosed in construction.
- C. "Exposed" means visible in sight or not installed "concealed" as defined above.
- D. "Approved Equal" means any equipment or material which is approved by the Engineer and equal in quality, durability, appearance, strength, design and performance to the equipment or material originally specified.
- E. "Conduit" shall mean all conduit including fittings, joints, hangers and supports.
- F. "Furnish" shall mean to purchase and deliver to the project site complete with every necessary appurtenance and support, all as part of the electrical work.
- G. "Install" shall mean to perform every operation necessary to establish secure mounting and correct operation at the proper location in the project, all as part of the electrical work.
- H. "Provide" shall mean to furnish and install.

1.19 QUALITY ASSURANCE

- A. Obtain services of manufacturer's representatives of electrical equipment, during erection and construction of their respective equipment to insure proper installation of same.
- B. A letter is required from each system manufacturer's representative certifying to the A/E that requirements have been checked and are properly installed and operating.

1.20 PERFORMANCE TESTS - ELECTRICAL

- A. Test and adjust the electrical systems and equipment during the progress of the work.
- B. Upon completion of work and after preliminary tests to assure that all systems are complete and in proper working order, arrange with the A/E to conduct performance tests of the electrical systems. These tests may be witnessed by the A/E prior to acceptance of systems and shall be arranged for the purpose of demonstrating compliance with contract documents. During this period,

- visually inspect all electrical equipment. Lighting fixtures shall be tested with specified lamps in place for not less than six (6) hours. Check voltages to assure that all transformer taps are properly set.
- C. General operating tests shall be performed under as near design conditions as possible, for a period of not less than one (1) hour for each system, and shall demonstrate that all equipment is functioning in accordance with specifications. Furnish all instruments, ladders, test equipment and personnel required for tests. Any equipment or systems found by test to be deficient or unsatisfactory shall be replaced and tests repeated as often as necessary to assure compliance with contract documents.
 - D. Test all feeders, sub-feeders and all branch wiring for amperage, voltage, phase balance, phase sequence of A,B,C and insulation resistance, then submit the results of this test to the A/E neatly typed in triplicate for review. This test may be conducted at any time up to, through and including, the guarantee period if requested by the A/E, at no additional cost to the Owner.
 - E. Phase balance the complete electrical system, phase balance all panels as near as loads will permit under normal working conditions.
 - F. Test all ground conductors for current flow, as near design operating conditions as possible. If any measured current exceeds one (1) ampere, determine and correct the cause. Also, if measured resistance is greater than 5 ohms indoor or 10 ohms outdoor, determine and correct the cause.
 - G. During the progress or completion of the work it shall be subject to the inspection of the Owner and to such other inspectors, as may have jurisdiction, including those of the Electric Company, Fire Department and the Telephone Company.
 - H. The Contractor shall be responsible for correct voltages, tap settings, trip settings and correct phasing on all equipment. Secondary voltages shall be measured at the line side of the main breakers with the breakers in an open position, at panelboards, and at such other location on the distribution systems and branch circuits as directed by the Engineer.
 - I. At completion of the work, Contractor shall submit to the Owner's representative in writing a statement stating: (1) that the work is complete; (2) that the entire installation is in accordance with the drawings and specifications; (3) that preliminary tests have been made; and (4) that the work is ready for final inspection and test.
 - J. A final inspection of the installation to determine compliance with the drawings and specifications will be made by the Owner's representative. Work will be checked for quality of materials, quality of workmanship, proper installation and finished appearance. The electrical contractor shall provide the services of the project electrical foreman for inspection purposes. The foreman shall remove and reinstall wiring devices, junction box covers, panelboard trims, switchboard covers, terminal box covers, ceiling tiles, lighting fixtures, etc. as required to facilitate any inspections required by the Owner's representative.
 - K. The Contractor shall arrange and conduct operating tests on all equipment in the presence of the Owner's representative. The components parts of systems and the various systems shall be demonstrated to operate in accordance with the requirements and intent of this specification. Any non-complying or defective materials or workmanship disclosed as a result of the inspection and tests shall be corrected promptly by the Contractor, and the tests repeated as often as necessary until approved and accepted by the Owner's representative.
 - L. The Contractor shall visit the site to acquaint himself with existing conditions. No extra compensation will be paid for failure to comply with this paragraph.
 - M. The Electrical Contractor shall provide supervision, labor, materials, tools, test equipment, and all other equipment or services and expenses required to test, adjust, set, calibrate, and operationally check work and components of the electrical systems and circuitry throughout this section.
 - N. The electrical contractor shall pay for all tests including expences incident to retests occasioned by defects and failures of equipment to meet specifications at no additional cost to the owner.
 - O. Any defects or deficiencies discovered in any of the electrical work shall be corrected at no cost to the owner.
 - P. All testing shall be compatible with the manufacturer's installation instructions.

1.21 SEISMIC RESTRAINT

- A. It is the intent of this seismic specification to keep all electrical building system components in place during a seismic event.

- B. All electrical systems must be installed in strict accordance with seismic codes, component manufacturer's and building construction standards. Whenever a Conflict occurs between the manufacturer's or construction standards, the most stringent shall apply.
- C. This contractor shall engage a professional structural engineer registered in the jurisdiction of this project to review the entire installation to determine all seismic restraint requirements and methods. Contractor shall submit a report outlining the structural engineer's review as well as seismic restraint shop drawings and supporting calculations prepared by the professional structural engineer for review by the Architect.
- D. Seismic restraints shall be designed in accordance with seismic force levels as detailed in the applicable building code.

1.22 TEMPORARY LIGHT AND POWER

- A. Under this Section of the specifications, this Contractor shall provide temporary electric service, sized suitable for construction for each trade. This contractor shall provide all material and labor for temporary electrical service per the local power company's requirements and standards with all necessary panelboards, disconnect switches, transformers, conduit, wiring, etc. as required. This contractor shall pay all associated costs, up front.
- B. Where temporary electrical service cannot be obtained from the local power company, this contractor shall provide a temporary, on-site, electric generator with all necessary panelboards, disconnect switches, transformers, conduit, wiring, etc. as required. The fuel used for the generator shall be provided and paid for by this Contractor.
- C. This contractor shall provide a distribution system with circuits for receptacles and lighting as required for construction. This contractor shall maintain the temporary electrical system during construction and remove the system when construction is complete.
- D. Under this section of the specifications, this Contractor shall provide and maintain temporary lighting based on using not less than one 100-watt lamp for each 100 square feet of building floor area and one duplex GFCI receptacle for each 200 square feet of building floor area. Where higher lighting intensities are required by Federal or State laws or otherwise specified, the above specified wattage shall be increased to provide the increase intensities.
- E. This contractor shall provide temporary power and telephone services from the local telephone company for site trailers, fax machines, computers, etc., per the general contractor's direction.
- F. The service shall incorporate ground fault protection and comply with NEC Article 527 and OSHA requirements.

1.23 PERMITS

- A. Obtain all required electrical permits and pay all fees for same.
- B. Provide to Engineer, in duplicate, a certificate of final inspection from the authority having jurisdiction for the electrical and systems.

1.24 OPERATING, INSTRUCTION, AND MAINTAINANCE MANUALS

- A. Refer to Section 017000 – CONTRACT CLOSEOUT for submittal procedures pertaining to operating and maintenance manuals.
- B. Each copy of the approved operating and maintenance manual shall contain copies of approved shop drawings, equipment literature, cuts, bulletins, details, equipment and engineering data sheets and typewritten instructions relative to the care and maintenance for the operation of the equipment, all properly indexed.

1.25 BIDDERS REPRESENTATION

- A. By the act of submitting a bid for the proposed contract, the Bidder represents that:
1. The Bidder and all subcontractors the Bidder intends to use have carefully and thoroughly reviewed the drawings, specifications and other construction contract documents and have found them complete and free from ambiguities and sufficient for the purpose intended; further that,
 2. The Bidder and workmen, employees and subcontractors the Bidder intends to use are skilled and experienced in the type of construction represented by the construction contract documents bid upon; further that,
 3. Neither the Bidder nor any of the Bidder's employees, agents, intended suppliers or subcontractors have relied upon any verbal representations, allegedly authorized or unauthorized from the Owner, or the Owner's employees or agents including architects, engineers or consultants, in assembling the bid figure; and further that,
 4. The bid figure is based solely upon the construction contract documents and properly issued written addenda and not upon any other written representation.

1.26 UTILITY COMPANY & AGENCY COORDINATION

- A. This section includes, but is not limited to coordination with the following utilities, agencies and authorities having jurisdiction:
1. Power Company: This Contractor shall coordinate with the local utility power company and provide all material & labor required to comply with the utility power company's requirements and standards, prior to ordering any electrical equipment, such as, switchgear, panels, transformers, disconnect switches, SPD, etc. This Contractor shall confirm metering sequence (hot or cold) and make the appropriate provisions and/or changes for the utility companies approved metering sequence arrangement. Notify Engineer of discrepancies between the plans and the local utility company's standards. No extra compensation will be given for corrections required to this Contractor for failure to coordinate with the utility company, but corrections shall be made. All A.I.C. ratings, grounding, bonding, concrete pads & curbs, protective bollards, raceways, ductbank, manholes, etc., shall be in accordance with the utility company's standards.
 2. Telephone Company: This Contractor shall coordinate with the local telephone company and provide all material & labor required to comply with the telephone company's requirements and standards, prior to ordering any electrical or telephone equipment, such as, terminal boards, grounding systems, raceways, ductbanks, manholes, etc. This Contractor shall confirm the telephone company's requirements and provide as necessary. Notify Engineer of discrepancies between the plans and the telephone company's standards. No extra compensation will be given for corrections required to this Contractor for failure to coordinate with the telephone company, but corrections shall be made.
 3. Cable TV Company: This Contractor shall coordinate with the local cable TV company and provide all material & labor required to comply with the cable TV company's requirements and standards, prior to ordering any electrical or cable TV equipment, such as, terminal boards, grounding systems, raceways, ductbanks, manholes, etc. This Contractor shall confirm the cable TV company's requirements and provide as necessary. Notify Engineer of discrepancies between the plans and the cable TV company's standards. No extra compensation will be given for corrections required for failure to coordinate with the cable TV company, but corrections shall be made.
 4. Local Fire Marshal: This contractor shall verify with the local fire alarm official, the type of master-box or municipal connection required for this project. This contractor shall provide all material & labor to comply with the local municipality. Notify Engineer of discrepancies between the plans and the municipality's standards. No extra compensation will be given for corrections required for failure to coordinate with the municipality, but corrections shall be made.
 5. Electrical Inspector: Review plans and specifications with the local electrical and/or wiring inspector(s). Obtain and pay for all permits.
 6. Building Inspector: Review plans and specifications with the local building inspector, if not done so by the General Contractor.
 7. OSHA Representative: Review plans and specifications with the local OSHA representative, if not done so by the General Contractor.

8. Dig Safe: This contractor shall notify and coordinate with Dig Safe prior to any excavation; digging; trenching; grading; tunneling; augering; boring; drilling; pile driving; plowing-in or pulling-in pipe, cable, wire, conduit, or other sub-structure; backfilling; demolition; and blasting related to this Contractor.
- B. The Electrical Contractor shall pay for all permits, inspections, labor, material and fees associated with the various Utility Companies coordination requirements mentioned in this section and for this Contractor's work under this project.
- C. The Electrical Contractor shall carry a minimum of \$15,000 of utility expenses. In the case the expenses are less than the carried expense, the difference will be credited to the owner. In the case the utility charges are more than the carried expense, the remaining payment shall be coordinated between the Electrical Contractor, General Contractor and Owner.
- D. HVAC, Plumbing, Fire Protection, and Electrical Drawings are diagrammatic. They indicate general arrangements of mechanical and electrical systems and other work. They do not show all offsets required for coordination nor do they show the exact routings and locations needed to coordinate with structural and other trades and to meet Architectural requirements.
- E. In all spaces, prior to installation of visible material and equipment, including access panels, review Architectural Drawings for exact locations and where not definitely indicated, request information from Architect. Where the electrical work shall interfere with the work of other trades, assist in working out the space conditions to make satisfactory adjustments before installation. Without extra cost to the Owners, make reasonable modifications to the work as required by normal structural interferences. Pay the General Contractor for additional openings or relocating and/or enlarging existing openings through concrete floors, walls, beams and roof required for any work which was not properly coordinated. Maintain maximum headroom at all locations. All piping, duct, conduit, and associated components to be as tight to underside of structure as possible.
- F. If any electrical work has been installed before coordination with other trades so as to cause interference with the work of such trades, all necessary adjustments and corrections shall be made by the trades involved without extra cost to the Owners.
- G. Where conflicts or potential conflicts exist and engineering guidance is desired, submit sketch of proposed resolution to Architect and Engineer for review and approval.

PART 2 – PRODUCTS

2.1 CONDUIT

- A. Minimum Size: ¾-inch, unless otherwise specified.
- B. Underground Installations:
 1. More than Five Feet from Foundation Wall: Use thick wall nonmetallic conduit concrete encased.
 2. Within Five Feet from Foundation Wall: Use rigid steel conduit concrete encased.
 3. In or Under Slab on Grade: Use plastic coated conduit.
 4. Minimum Size: 1-inch.
- C. Outdoor Locations, Above Grade: Use rigid steel conduit.
- D. In Slab Above Grade:
 1. Use rigid steel conduit.
 2. Maximum Size Conduit in Slab: ¾ inch (19 mm); ½ inch (13 mm) for conduits crossing each other.
- E. Wet and Damp Locations: Use rigid aluminum conduit.
- F. Dry Locations:
 1. Concealed and in Cable-Tray: Use metal clad (MC) cable (see Division 1)
 2. Exposed: (Unfinished or utility spaces) Use electrical metallic tubing.
- G. Metal conduit: Rigid Steel Conduit shall comply with ANSI C80.1 and be heavy wall zinc coated steel. Rigid Aluminum Conduit shall comply with ANSI C80.5. Intermediate Metal Conduit (IMC) shall be rigid steel. Fittings and Conduit Bodies shall comply with ANSI/NEMA FB 1 and material to match conduit. Acceptable manufacturers are Western Tube and Conduit Company, Allied Tube and Conduit Company and Triangle Wire and Cable, Inc.

- H. Flexible metal conduit shall be interlocked aluminum construction. Fittings shall comply with ANSI/NEMA FB 1. Acceptable manufacturers are AFC Cable Systems, Electri-Flex Company and Eastern Flexible Conduit Technologies. All flexible conduits shall include a grounding conductor.
- I. Electrical metallic tubing (EMT) shall comply with ANSI C80.3; galvanized zinc coated steel tubing. Fittings and Conduit Bodies shall comply with ANSI/NEMA FB 1; steel, compression or set screw type. Acceptable manufacturers are Western Tube and Conduit Company, Allied Tube and Conduit Company and Triangle Wire and Cable, Inc.
- J. Nonmetal conduit shall comply with NEMA TC 2; Schedule 40 PVC, or as indicated on plans. Fittings and Conduit Bodies shall comply with NEMA TC 3. Acceptable manufacturers are Carlon or approved equal.
- K. Flexible nonmetallic conduit (Sealtite) shall be UL and CSA listed for purpose specified and shown. Acceptable manufacturers are Carlon or approved equal.
- L. Install conduit in accordance with NECA "Standard of Installation." Install nonmetallic conduit in accordance with manufacturer's instructions.
- M. Arrange supports to prevent misalignment during wiring installation. Support conduit using coated steel or malleable iron straps, lay-in adjustable hangers, clevis hangers, and split hangers. Group related conduits; support using conduit rack. Construct rack using steel channel; provide space on each for 25 percent additional conduits. Fasten conduit supports to building structure and surfaces under provisions of Division 1. Do not support conduit with wire or perforated pipe straps. Remove wire used for temporary supports. Do not attach conduit to ceiling support wires.
- N. Arrange conduit to maintain headroom and present neat appearance. Route exposed conduit parallel and perpendicular to walls. Route conduit installed above accessible ceilings parallel and perpendicular to walls. Route conduit in and under slab from point-to-point. Do not cross conduits in slab.
- O. Maintain adequate clearance between conduit and piping. Maintain 12-inch (300 mm) clearance between conduit and surfaces with temperatures exceeding 104 degrees F (40 degrees C).
- P. Cut conduit square using saw or pipe cutter; de-burr cut ends. Bring conduit to shoulder of fittings; fasten securely. Join nonmetallic conduit using cement as recommended by manufacturer. Wipe nonmetallic conduit dry and clean before joining. Apply full even coat of cement to entire area inserted in fitting. Allow joint to cure for 20 minutes, minimum. Use conduit hubs or sealing locknuts to fasten conduit to sheet metal boxes in damp and wet locations and to cast boxes.
- Q. Install no more than equivalent of three 90-degree bends between boxes. Use conduit bodies to make sharp changes in direction, as around beams. Use hydraulic one-shot bender to fabricate or factory elbows for bends in metal conduit larger than 2-inch (50 mm) size.
- R. Avoid moisture traps; provide junction box with drain fitting at low points in conduit system. Provide suitable fittings to accommodate expansion and deflection where conduit crosses seismic, control and expansion joints. All expansion and deflection fittings shall have a ground strap. Provide suitable pull string in each empty conduit except sleeves and nipples. Use suitable caps to protect installed conduit against entrance of dirt and moisture.
- S. Ground and bond conduit under provisions of NEC 250.

2.2 SURFACE RACEWAYS

- A. Multi-outlet assemblies shall be steel channel with fitted cover suitable for use as multi-outlet assembly. There shall be two compartments separated by a steel divider: one for power wiring and one for tele/data wiring. Provide flush feed box equal to Wiremold #WSA42-4 with backfeed kit #WSA86. Color of surface raceway per the Architect and Owner.
- B. Provide 125-volt, 20 amp duplex receptacles with ground slot spaced 12 inches (300 mm) on center or as indicated on the plans. Color of receptacles per the Architect and Owner.
- C. Provide tele/data outlets spaced 12 inches (300 mm) on center or as indicated on the plans. The number of jacks per tele/data outlet as indicated or as required per the Owner. Color of outlets per the Architect and Owner.
- D. Provide cover plates equal to Wiremold #4049.
- E. Coordinate with Architect and Owner for exact height of surface raceway prior to installing any material. De-rate conductors as required per code. Coordinate with furniture supplier and millwork supplier to

avoid conflicts with counter wall supports and surface raceways. Coordinate bushed openings in counters for cord & plug connections, where receptacles will be installed under counters.

- F. Acceptable manufacturers are Wiremold Company, Hubbell or approved equal.
- G. Fittings: Furnish manufacturer's standard couplings, elbows, outlet and device boxes, and connectors.
- H. Wireways shall be steel with rust inhibiting primer coating with gray enamel finish for general wiring in unfinished spaces. Provide as necessary per the job conditions.
- I. Install and mount products in accordance with the manufacturer's instructions. Use flat-head screws, clips, and straps to fasten raceway channel to surfaces. Mount plumb and level. Use suitable insulating bushings and inserts at connections to outlets and corner fittings. Close ends of wireway and unused conduit openings. Ground and bond under provisions of NEC 250.

2.3 DUCT BANK

- A. Verify that field measurements are as indicated. Verify routing and termination locations of duct bank prior to excavation for rough-in. Verify locations of manholes prior to excavating for installation. Duct bank routing is shown in approximate locations unless dimensions are indicated. Route as required to complete duct system. Manhole locations are shown in approximate locations unless dimensions are indicated. Locate as required to complete duct bank system.
- B. Underground Warning Tape: Provide 3-inch-wide plastic tape 12" below finished grade, colored yellow with suitable warning legend describing buried electrical lines; Model #47586 as manufactured by Seton or equal.
- C. Install duct to locate top of duct bank at 30" below finished grade or at depths as indicated on drawings. Install duct with minimum slope of 4-inches per 100-feet. Slope duct away from building entrances.
- D. Provide suitable fittings to accommodate expansion and deflection where required. Terminate duct at manhole entries using end bell. Stagger duct joints vertically in concrete encasement 6 inches minimum. Use suitable separators and chairs installed not greater than 4 feet (1200 mm) on centers. Band ducts together before backfilling and placing concrete. Securely anchor duct to prevent movement during concrete placement.
- E. Place concrete as required and under provisions of Division 3. Use mineral pigment to color concrete red. Provide minimum 3-inch concrete cover at bottom, top, and sides of duct bank. Provide two No. 4 steel reinforcing bars in concrete ductbank under paved areas. Connect to existing concrete encasement using dowels. Connect to manhole wall using dowels.
- F. Provide suitable pull string in each empty duct except sleeves and nipples. Swab duct. Use suitable caps to protect installed duct against entrance of dirt and moisture.
- G. Backfill trenches as required and under provisions of Division 31. Interface installation of underground warning tape with backfilling specified in Division 31. Install warning tape 12-inches below finished surface.

2.4 BUILDING WIRE & CABLE

- A. Building Wire and Cable shall be copper with 600V insulation rated at 75°C minimum, Type XHHW insulation for feeders and branch circuits larger than #3 AWG; Type THHN/THWN insulation for feeders and branch circuits #4 AWG and smaller.
- B. Conductors shall be of soft drawn 98% minimum conductivity properly refined copper, solid construction where No. 10 AWG and smaller, stranded construction where No. 8 AWG and larger.
- C. Exterior of wires shall bear repetitive markings along their entire length indicating conductor size, insulation type and voltage rating.
- D. Exterior of wires shall be color coded, so as to indicate a clear differentiation between each phase and between each phase and neutral. In all cases, grounded neutral wires and cables shall be identified by the colors "white" or "gray". In sizes and insulation types where factory applied colors are not available, wires and cables shall be color coded by the application of colored plastic tapes in overlapping turns at all terminal points, and in all boxes in which splices are made. Colored tape shall be applied for a distance of 6 inches along the wires and cables, or along their entire extensions beyond raceway ends, whichever is less.
- E. Final connections to motors shall be made with 18" of neoprene sheathed flexible conduit.

- F. Minimum branch circuit conductor size shall be No. 12 AWG installed in conduit. Motor control circuit wiring shall be minimum No. 14 AWG installed in conduit.
- G. Fire alarm and security system wiring shall be No. 16 twisted non-shielded pairs for alarm and trouble circuits and a minimum of #14 AWG for device power, control and alarm annunciation circuits. Fire alarm system riser circuits shall be 2-hour rated, CI type (circuit integrity) cable per NFPA 72 and NEC 760.
- H. Other wires and cables required for the various systems described elsewhere in this section of the Specifications shall be as specified herein, as shown on the Contract Drawings, or as recommended by the manufacturer of the specific equipment for which they are used, all installed in conduit.
- I. Metal clad sheathed cable NFPA 70, type MC may be used for branch circuitry where shown and where run concealed and not subject to physical damage. All branch circuits shall be run in conduit from the panelboard to the first outlet. All type MC cable used shall contain a full-size insulated ground conductor. All conductors shall be copper. All type MC cable insulation used shall have voltage rating of 600 volts, shall have a temperature rating of 75° C, and shall be thermoplastic material. Armor material shall be steel and armor design shall be interlocked metal tape. Fire alarm rated MC cable may be used for fire alarm work where concealed and approved by the Authority Having Jurisdiction.
- J. Metal-Clad cable (Type MC) for circuits supplying computer equipment, electronic discharge lighting and other sensitive electronic equipment shall consist of 90°C THHN copper conductors with insulated ground and oversized neutral conductor (or one full size neutral conductor for each phase conductor). Cable shall be U.L. listed/labeled and shall meet the requirements of NEC Art. 334 and 675.
- K. Use armored cable (AFC Type HCF-90 or equal) for branch circuits and feeders in areas of patient care in hospitals, nursing homes and medical centers, medical office buildings and nurses' office areas of schools. This cable shall consist of 90°C THHN copper conductors with combined armor/bond wire (equipment) plus a green insulated ground (redundant). Use insulated bushings. Cable shall be U.L. listed/labeled, and shall meet the requirements of NEC Art. 333, 517 and 645.
- L. Use armored cable (AFC Type HCF-90 or equal) for branch circuits and feeders in all buildings in the following areas; data processing systems, places of assembly, under raised floors, above suspended ceilings and in other environmental air-handling spaces. This cable shall consist of 90°C THHN copper conductors with combined armor/bond wire (equipment) plus a green insulated ground (redundant). Use insulated bushings. Cable shall be U.L. listed/labeled, and shall meet the requirements of NEC Art. 333, 517 and 645.
- M. Mineral-insulated metal-sheathed fire-resistive cables, type MI, shall consist of a factory assembly of one or more solid copper conductors insulated with highly compressed magnesium oxide and enclosed in a seamless, liquid and gas-tight continuous copper sheath. Cables shall be rated for 600 volts. Cable shall comply with Article 330 of the National Electrical Code. Cables shall be classified by Underwriters Laboratories, Inc. as having a 2-hour fire resistive rating. Cable terminations shall be made with UL listed mineral-insulated cable fittings. Installation of MI cables shall be in accordance with the manufacturer's instructions. Cables shall be as manufactured by Pyrotenax USA, Inc., or approved equal.
- N. Wiring materials except MI cable shall be manufactured by Triangle, Essex, General Cable, AFC, Southwire or equal.
- O. Concealed Dry Interior Locations: Use only building wire Type THHN/THWN or XHHW insulation in raceway, or metal clad cable where concealed and code acceptable.
- P. Exposed Dry Interior Locations: Use only building wire, Type THHN/THWN or XHHW insulation, in raceway.
- Q. Above Accessible Ceilings: Use only building wire, Type THHN/THWN or XHHW insulation, in raceway or metal clad cable where code acceptable.
- R. Wet or Damp Interior Locations: Use only building wire, Type THHN/THWN or XHHW insulation, in raceway.
- S. Exterior Locations: Use only building wire, Type THHN/THWN or XHHW insulation, in raceway.
- T. Underground Installations: Use only building wire, Type THHN/THWN or XHHW insulation, in raceway.
- U. Wiring methods, in general, are as follows:
 - 1. Galvanized rigid steel conduit shall be used for telephone system sleeves for main cable runs between floors, closets, etc. and for sweeps, bends, etc. in ductbanks and as specifically noted on the plans. EMT shall be used generally for exposed circuiting in unfinished spaces. Metal

- clad cable (type MC) may be used for branch circuiting and fire alarm rated MC cable for fire alarm circuiting where run concealed and where code acceptable.
2. To prevent transmittal of vibration to conduit, connections to any vibration producing equipment (i.e. transformers, motors, etc.) shall be terminated by 18 inches of flexible metal conduit. Where flexible connections are exposed to grease and oil, liquid-tight flexible metal conduit shall be used.
 3. In general, no splices or joints shall be permitted in either feeders or branches except at outlets or accessible junction boxes. Splices in wire #8 AWG and smaller shall be pigtail type, made mechanically tight. All conduit systems shall be complete.
 4. Raceway, boxes, etc., run on walls in wet areas which are subject to being washed down, shall be mounted on the walls with 1/4" stand-offs. All boxes shall be cast type.
- V. Route wire and cable as required to meet the Project Conditions. Install cable in accordance with the NECA "Standard of Installation." Use solid conductor for feeders and branch circuits 10 AWG and smaller. Use stranded conductors for control circuits. Use conductor not smaller than 12 AWG for power and lighting circuits. Use conductor not smaller than 16 AWG for control circuits. Use 10 AWG conductors for 20 amperes, 120 volt branch circuits longer than 75 feet. Pull all conductors into raceway at same time. Use suitable wire pulling lubricant for building wire 4 AWG and larger. Protect exposed cable from damage.
- W. Support cables above accessible ceiling, using spring metal clips or metal cable ties to support cables from structure or ceiling suspension system, cables that are not part of the ceiling system cannot be supported from ceiling supports. Do not rest cable on ceiling panels. Use suitable cable fittings and connectors. Neatly train and lace wiring inside boxes, equipment, and panelboards.
- X. Clean conductor surfaces before installing lugs and connectors. Make splices, taps, and terminations to carry full ampacities of conductors with no perceptible temperature rise. Use suitable reducing connectors or mechanical connector adapters for connecting aluminum conductors to copper conductors. Use split bolt connectors for copper conductor splices and taps, 6 AWG and larger. Tape un-insulated conductors and connector with electrical tape to 150 percent of insulation rating of conductor. Use solderless pressure connectors with insulating covers for copper conductor splices and taps, 8 AWG and smaller. Use insulated spring wire connectors with plastic caps for copper conductor splices and taps, 10 AWG and smaller. Identify and color code wire and cable. Identify each conductor with its circuit number or other designation indicated.

2.5 BOXES

A. Outlet Boxes:

1. Each outlet in wiring or raceway systems shall be provided with an outlet box to suit conditions encountered. Boxes installed in normally wet locations shall be of cast-metal type having hubs. Concealed boxes shall be cadmium plated or zinc coated sheet metal type. Old work boxes with Madison clamps are not allowed in new construction.
2. Each box shall have sufficient volume to accommodate number of conductors in accordance with requirements of NFPA 70. Boxes shall not be less than 1-1/2" deep unless shallower boxes are required by structural conditions and are specifically approved by Architect. Ceiling and bracket outlet boxes shall not be less than 4" octagonal except that smaller boxes may be used where required by particular fixture to be installed. Flush or recessed fixtures shall be provided with separate junction boxes when required by fixture terminal temperature requirements. Switch and receptacle boxes shall be 4" square or of comparable volume. Luminaire and equipment supporting boxes shall be rated for weight of equipment supported; include 1/2 inch (13 mm) male fixture studs where required.
3. Provide metallic boxes rated for 2-hour, fire-rated walls with gasket to reduce noise-transmission in all fire-rated walls. A minimum horizontal distance of 24-inches shall separate metallic boxes located on opposite sides of walls. This minimum horizontal spacing may be reduced using UL classified wall opening protective materials, commonly known as "putty pads" or "insert pads" pending written approval from the local authority having jurisdiction

(AHJ). Refer to Architect's plans for all wall types prior to bid and any related work that will require 2-hour fire ratings.

4. Acceptable Manufacturers:
 - a. Appleton
 - b. Crouse Hinds
 - c. Steel City
 - d. RACO
- B. Pull and Junction Boxes: Where necessary to terminate, tap off, or redirect multiple raceway runs or to facilitate conductor installation, furnish and install appropriately designed boxes. Boxes shall be fabricated from code gauge steel assembled with corrosion resistant machine screws. Box size shall be as required by Code. Where intermediate cable supports are necessary because of box dimensions, provide insulated removable core brackets to support conductors. Junction boxes are to be equipped with barriers to separate circuits. Where splices are to be made, boxes shall be large enough to provide ample work space. All conductors in boxes are to be clearly tagged to indicate characteristics. Boxes shall be supported independently of raceways. Junction boxes in moist or wet areas shall be galvanized type. Boxes larger than 4-inches square shall have hinged covers. Boxes larger than 12-inches in one dimension will be allowed to have screw fastened covers, if a hinged cover would not be capable of being opened a full 90 degrees due to installation location.
- C. Fiberglass Handholes shall be die molded glass fiber. Cable Entrance shall be pre-cut 6-inch x 6-inch (150 mm x 150 mm) cable entrance at center bottom of each side. Cover shall be glass fiber weatherproof cover with nonskid finish.
- D. Install boxes in accordance with NECA "Standard of Installation." Install in locations as shown on Drawings, and as required for splices, taps, wire pulling, equipment connections and compliance with regulatory requirements.
- E. Set wall mounted boxes at elevations to accommodate mounting heights indicated or specified in section for outlet device. Electrical boxes are shown on drawings in approximate locations unless dimensioned. Adjust box location up to 10-feet (3m) if required to accommodate intended purpose. Orient boxes to accommodate wiring devices. Maintain headroom and present neat mechanical appearance.
- F. Install pull boxes and junction boxes above accessible ceilings and in unfinished areas only. Inaccessible Ceiling Areas: Install outlet and junction boxes no more than 6 inches (150 mm) from ceiling access panel or from removable recessed luminaire. Install boxes to preserve fire resistance rating of partitions and other elements, using materials and methods specified in Division 7.
- G. Coordinate mounting heights and locations of outlets mounted above counters, benches, and backsplashes. Locate outlet boxes to allow luminaires positioned as shown on reflected ceiling plan. Align adjacent wall mounted outlet boxes for switches, thermostats, and similar devices.
- H. Use flush mounting outlet box in finished areas. Locate flush mounting box in masonry wall to require cutting of masonry unit corner only. Coordinate masonry cutting to achieve neat opening. Do not install flush mounting box back-to-back in walls; provide minimum 6-inches separation. Provide minimum 24 inches (600 mm) separation in acoustic rated walls. Secure flush mounting box to interior wall and partition studs. Accurately position to allow for surface finish thickness. Use stamped steel bridges to fasten flush mounting outlet box between studs. Install flush mounting box without damaging wall insulation or reducing its effectiveness.
- I. Use adjustable steel channel fasteners for hung ceiling outlet box. Do not fasten boxes to ceiling support wires. Support boxes independently of conduit. Use gang box where more than one device is mounted together. Do not use sectional box. Use gang box with plaster ring for single device outlets. Use cast outlet box in exterior locations exposed to the weather and wet locations. Use cast floor boxes for installations in slab on grade; formed steel boxes are acceptable for other installations. Set floor boxes level.
- J. Large Pull Boxes: Use hinged enclosure in interior dry locations, surface-mounted cast metal box in other locations.
- K. Adjust floor box flush with finish flooring material. Adjust flush-mounting outlets to make front flush with finished wall material. Install knockout closures in unused box openings.

2.6 WIRING DEVICES

- A. Provide wiring device type plates for all wall-mounted devices. All wall plates shall be either brushed aluminum or smooth high impact nylon for all public areas as directed by the Architect. Provide galvanized steel for all Utility, Electric and Mechanical Rooms. Colors of wall plates as directed by the Architect.
- B. Wiring devices standard for the project (i.e., with no specific type indicated) shall conform to the following:
 - 1. Visible part colors of wiring devices shall be as directed by the Architect for all public areas. Provide Ivory colored devices for all Utility, Electrical and Mechanical rooms.
 - 2. Exclude compact type devices.
- C. Wiring device switches shall be toggle type, A.C. quiet design, specification grade, 20 amps on 120-volt circuits. Switches shall be mounted 48-inches to center line above finished floor unless noted otherwise. Equivalent 277volt, 20 amp switches shall be used where required.
- D. Standard duplex convenience receptacles shall be 125volt, 20 amps, three wire (two circuit wires plus ground), "U-slot" ground NEMA configuration 5-20R, specification grade. Receptacles shall be mounted 18" to center line above finished floor unless noted otherwise. Where indicated on plans provide receptacles with ground fault current interrupters, UL Class A; 20A, 125V.
- E. All nonlocking type 15A and 20A, 125v receptacles in the following areas of the dwelling units [NEC 210.52] shall be listed as tamper-resistant [NEC 406.12].
 - 1. wall space — NEC 210.52(A)
 - 2. small-appliance circuit — NEC 210.52(B)
 - 3. countertop space — NEC 210.52(C)
 - 4. bathroom area — NEC 210.52(D)
 - 5. outdoors — NEC 210.52(E)
 - 6. laundry area — NEC 210.52(F)
 - 7. garage and outbuildings — NEC 210.52(G)
 - 8. hallways — NEC 210.52(H)
- F. Non-standard convenience receptacles and special purpose power supply receptacles shall be as listed on plans.
- G. Provide ground fault circuit interrupter (GFCI), weather-resistant type receptacles in all wet and damp locations as defined by the National Electrical Code. All outdoor receptacles and where indicated on the plans shall be installed in a weatherproof while-in-use enclosures.
- H. Weatherproof Receptacle Enclosures shall be NEMA 3R rated for rain-tight while-in-use, gasketed, impact resistant thermoplastic with hinged gasketed device cover.
- I. Provide extension rings to bring outlet boxes flush with finished surface. Clean debris from outlet boxes. Install devices plumb and level. Install receptacles with grounding pole on top. Connect wiring device grounding terminal to branch circuit equipment grounding conductor. Use jumbo size plates for outlets installed in masonry walls. Install galvanized steel plates on outlet boxes and junction boxes in unfinished areas, above accessible ceilings, and on surface mounted outlets.
- J. Install wall switch 48 inches above finished floor to top of handle. On position, shall be up. Install convenience receptacles 18-inches above finished floor. Install convenience receptacle 6-inches above backsplash of counter. Install dimmer switches 48 inches above finished floor to top.
- K. Verify that each receptacle device is energized. Test each receptacle device for proper polarity. Test each GFCI receptacle device for proper operation.

2.7 CABINETS & ENCLOSURES

- A. Cabinets shall be as follows: Boxes: Galvanized steel. Box Size: As required and/or indicated on plans. Backboard: Provide 3/4-inch-thick plywood backboard for mounting terminal blocks. Paint matte white. Fronts: Steel, flush type with concealed trim clamps, door with concealed hinge, and flush lock keyed to match branch circuit panelboard. Finish with gray baked enamel. Knockouts: As required and/or indicated on plans. Provide metal barriers to form separate compartments wiring of different systems and voltages. Provide accessory feet for free-standing equipment.
- B. Hinged Cover Enclosures shall be as follows: Construction: NEMA 250, Type 1, 3R, or 4 steel enclosure, as required and/or indicated on plans. Covers: Continuous hinge, held closed by flush latch operable by key or hasp and staple for padlock. Provide interior plywood panel for mounting terminal

blocks and electrical components, finish with white enamel. Enclosure Finish: Manufacturer's standard enamel.

- C. Install in accordance with NECA "Standard of Installation." Install enclosures and boxes plumb. Anchor securely to wall and structural supports at each corner under the provisions of Section 16190. Install cabinet fronts plumb.
- D. Clean electrical parts to remove conductive and harmful materials. Remove dirt and debris from enclosure. Clean finishes and touch up damage.
- E. ICS 4 - Terminal blocks for industrial control equipment and systems. Power Terminals: Unit construction type with closed back and tubular pressure screw connectors, rated 600 volts. Signal and Control Terminals: Modular construction type, suitable for channel mounting, with tubular pressure screw connectors, rated 300 volts. Provide ground bus terminal block, with each connector bonded to enclosure.
- F. Provide grounding provisions for all cabinets/enclosures and bond to grounding system as required per Code.

2.8 GROUNDING & BONDING

- A. Ground all systems and equipment in accordance with best industry practice, the requirements of NFPA 70 and the following:
 - 1. The ground bus of the main switchboard shall be connected to the main grounding electrode specified below by means of insulated conductors run in conduit.
 - 2. The main grounding electrode shall be an accessible point on the nearest metallic main water service pipe. Connection shall be made on the street side of the main valve utilizing a ground clamp of a type specifically manufactured for the purpose. Bonding jumpers shall be provided around the water meters and around insulating joints and/or sections.
 - 3. Establish a ground bonding connection from the effectively grounded structural building steel to each cold-water main entering the building. Each bonding connection shall consist of insulated conductors run in conduit.
 - 4. The water pipe ground shall be supplemented by an additional electrode consisting of three (3) buried 3/4" diameter by 10'-0" long copperweld ground rods spaced 10'-0" apart and provided in sufficient quantity so as to have measured resistance to ground of not more than 10 ohms. Provide independent certification confirming this. Establish a bonding connection from the electrode consisting of green insulated conductors run in conduit and sized as indicated hereinafter for main and supply side of service bonding jumpers.
 - 5. Provide grounding bonds between all metallic conduits of the light and power system which enter and leave cable chambers or other non-metallic cable pulling and splicing boxes. Accomplish this by equipping the conduits with bushings of the grounding type individually cross connected.
 - 6. Bond metallic conduits containing grounding electrode conductors and main bonding conductors to the ground bus service enclosure and/or grounding electrode at both ends of each run utilizing grounding bushings and jumpers.
 - 7. Provide grounding bonds for all metallic conduits of the light and power system which terminate in pits below equipment for which a ground bus is specified. Accomplish this by equipping the conduits with bushings of the grounding type connected individually to the ground bus.
 - 8. Provide supplementary ground bonding where metallic conduits terminate at metal clad equipment (or at the metal pull box of equipment) for which a ground bus is specified. Accomplish this by equipping the conduits with bushings of the grounding type connected individually by means of jumpers to the ground bus. Exclude the jumpers where directed. This exclusion will be required where an isolated ground for electronic equipment is to be maintained.
 - 9. Each grounding type bushing shall have the maximum ground wire accommodation available in standard manufacture for the particular conduit size. Connection to bushing shall be with wire of this maximum size.
 - 10. Bonding conductors on the load size of the service device and equipment grounding conductors shall be sized in relation to the fuses or trip size of the overcurrent device supplying the circuit.
 - 11. The central equipment for the fire protective alarm system and telephone system shall have its grounding terminal connected to the grounding electrode by means of a No. 6 green coded

insulated conductor, run in 3/4" conduit. Utilize a ground clamp of a type specifically manufactured for the purpose.

12. Install rod electrodes per this section & in compliance with Code. Install additional rod electrodes as required to achieve specified resistance to ground. Install 4/0 AWG bare copper wire in foundation footing as required. Provide isolated grounding conductor for circuits supplying personal computers as indicated on the plans. Equipment Grounding Conductor: Provide separate, insulated conductor within each feeder and branch circuit raceway. Terminate each end on suitable lug, bus, or bushing. Provide a 3/4" raceway with #6 AWG ground wire from main telephone terminal board to the service ground.
13. Perform inspections and tests listed in NETA ATS, Section 7.13. Document test results in Record Documents.
14. Grounding means shall never exceed 10 ohms when located outdoors, or 5 ohms when located indoors.
15. An acceptable means of grounding is to provide an underground 2" thick, concrete-encased electrode of either 1/2" diameter, electrically conductive reinforcing bar of #4/0 bare copper conductor (minimum of 20-feet in length) per NEC 250.52(A)(3).

2.9 EQUIPMENT WIRING SYSTEM

- A. Cords & Caps: Manufacturers: Hubbell, Pass & Seymour or Arrow Hart. Attachment Plug Construction: Conform to NEMA WD 1. Configuration: NEMA WD 6; match receptacle configuration at outlet provided for equipment. Cord Construction: ANSI/NFPA 70, Type SO multiconductor flexible cord with identified equipment grounding conductor, suitable for use in damp locations. Size: Suitable for connected load of equipment, length of cord, and rating of branch circuit overcurrent protection.
- B. Motor Control Equipment: Each motor shall have a starter furnished under this Section where it is not being supplied by other sections. Wire and installed under this Section, unless otherwise noted herein or on the drawings.
 1. Connect the motor starting devices for all motors, except where otherwise specifically provided for under other sections, furnish all necessary connections between controllers and motors, in conduit and leave motors ready to start. Change connections, if necessary, to secure proper rotation of motors.
 2. Perform all the necessary wiring in connection with the motor starting and remote control equipment, where so designated, furnished under other sections. Where control or starting equipment is sent to the job as individual units, they shall be installed, wired up complete and left ready for operation under work of this section.
 3. Wiring to motor shall be in rigid conduit with watertight flexible conduit from wall to motor only.
- C. Included in the general requirements for motor control equipment wiring and connections, the following specified items shall be performed:
 1. Installation and connection of motor controls which will be furnished under the heating, ventilating and air conditioning section and the plumbing section.
- D. Starters by This Contractor: Where starters are not provided under other sections, this Contractor shall furnish starters for motors 1/2 HP and larger and where required by the control sequence for smaller motors and shall be magnetic across the line starters with adjustable overload protection in each phase line, all in NEMA 1 enclosures. Starters shall be solid state or acceptable substitute. Combination starters shall be with fused or non-fusible disconnect as required.
 1. Magnetic starters shall have 120 volt holding circuits, integral transformers, auxiliary contacts as required by the control sequence and integral selector switches with push-to-test pilot lights. One side of each pilot light shall be connected on the load side of the motor starter.
 2. Integral transformers shall have overload protection on the secondary section and, also, the secondary neutral shall be grounded.
 3. Starters shall be as manufactured by Square D Company, Siemens or General Electric.
- E. Temperature control wiring shall be by others as indicated under the heating, ventilating and air conditioning section.
- F. Provide a suitable plywood backboard on a wall and/or angle iron or unistrut framework with plywood for all starters. Starters will be installed and wired under this section.

- G. All starters shall be located next to the panel feeding same, if panel is in a closet or utility space, unless noted otherwise on the drawings. If panel is located in a finished space (i.e. corridor, gymnasium, etc.) starters shall be located in a nearby utility closet or space acceptable to the Engineer.
- H. Nameplates: Each starter shall have a 1.0" x 2.5" hot stamped nameplate identifying the unit and panel it is fed from. The lettering shall be white 1/2" high in a black background.
- I. Connections to systems: Make electrical connections in accordance with equipment manufacturer's instructions. Make conduit connections to equipment using flexible conduit. Use liquid-tight flexible conduit with watertight connectors in damp or wet locations. Make wiring connections using wire and cable with insulation suitable for temperatures encountered in heat producing equipment. Provide receptacle outlet where connection with attachment plug is indicated. Provide cord and cap where field-supplied attachment plug is indicated. Provide suitable strain-relief clamps and fittings for cord connections at outlet boxes and equipment connection boxes. Install disconnect switches, controllers, control stations, and control devices as indicated. Modify equipment control wiring with terminal block jumpers as indicated. Provide interconnecting conduit and wiring between devices and equipment where indicated.
- J. Elevators:
1. The electrical contractor (E.C.) shall verify the horsepower, voltage, starting method (i.e.; across-the-line, solid-state, etc.), and recommended over-current protection with the elevator supplier, prior to installing any material. Coordinate with Engineer for any discrepancies between plans and actual elevator to be installed prior to ordering related electrical material.
 2. Provide a minimum of one (1) fire alarm system smoke detector in each elevator lobby, at each landing and in each machine room. Provide necessary connections between the smoke detectors and elevator controller for recall requirements. Coordinate with local authority having jurisdiction for primary and alternate recall landings.
 3. Provide a pit light and switch with convenience receptacle in each elevator pit; switch shall be accessible from pit access floor, located 18" above floor. The pit convenience receptacle shall have GROUND FAULT PROTECTION (GFCI). Provide GFCI type duplex convenience receptacles in each elevator machine room. Lighting in hoistways shall not be connected to the load side of the GFCI receptacle. Locate light fixture to avoid being struck by the elevator car or counter-weight; coordinate with elevator supplier. The switch shall be located so as to be readily accessible from the pit door.
 4. Provide a fused mainline heavy-duty disconnect switch in machine room with feeder wires to elevator controller, all piped in accordance with NEC, and grounded. Provide a #6 AWG, minimum, green colored ground for the disconnect switch and controller. Disconnect switch shall be located on the jamb side of the machine room door and shall be the type that cannot be engaged with the door open.
 5. Machine rooms shall have a minimum of seven (7) feet clear headroom under all obstructions, including light fixtures.
 6. Provide power and disconnects for all car lights, fans, car signals, viscosity control heaters, elevator controls and other provided equipment. Coordinate with elevator supplier for exact requirements.
 7. Only electrical equipment, wiring, devices, etc..., required for the operation of the elevator shall be permitted in the elevator machine room, pit and hoistway. All electrical equipment, devices, wiring, raceways, junction boxes, etc., foreign to the elevator shall not be installed in the elevator machine room or hoistway.
 8. Provide a dedicated GFCI receptacle and branch circuit (20A/125V) in a weather-proof while-in-use enclosure in each elevator pit for sump pump.
 9. Provide an ADA compliant telephone or intercom for each elevator.
 10. In hoistways, all electrical equipment located less than 48-inches above the pit floor shall be weatherproof (NEMA 4); and wiring shall be identified for use in wet locations in accordance with the requirements in NFPA 70.
 11. Where sprinklers are installed in elevator machine rooms or hoistways, E.C. shall provide with heat detectors (used to automatically disconnect the main line power supply to the elevator prior to the application of water from sprinklers) a set of normally closed contacts with wiring from the heat detector to a shunt trip circuit breaker in the panel supplying power to the elevator. The normally closed contacts shall be closed when the heat detector is not activated and shall be opened when the heat detector is activated.

12. Where an emergency return unit is provided with the elevator, the electrical contractor shall provide a set of auxiliary contacts with the elevator disconnect switch and wiring to the elevator controller, per ANSI/NFPA 70-1996, section 620-91(c). The auxiliary contacts shall be positively open when the disconnect switch is open. The auxiliary contacts shall cause the emergency return unit power source to be disconnected from its load when the disconnecting means is in the open position. Verify requirements with elevator supplier.
13. Provide fire alarm system connections for elevator cab "fire-fighters hat" indicator as required. Coordinate connection requirements with elevator and fire alarm system manufacturers as required.
14. Provide control modules that shall capture the elevator when the fire alarm system is activated and therefore bring the elevator cab to a pre-determined floor & alternate floor as required. Coordinate with elevator manufacturer & installer for connections and programming. Coordinate with fire department & architect for pre-determined floor and alternate floor.
15. Where hoistways have access doors, the electrical contractor shall provide control wiring in conduit between the access doors locking mechanisms and the elevator controller per the elevator manufacturer's instructions to lock-out the access doors from being opened while the elevator cab is traveling between floors.

2.10 SUPPORTING DEVICES

- A. Materials and Finishes: Provide adequate corrosion resistance. Provide materials, sizes, and types of anchors, fasteners and supports to carry the loads of equipment and conduit. Consider weight of wire in conduit when selecting products. Steel channel shall be galvanized.
- B. Anchors and Fasteners:
 1. Concrete Structural Elements: Use precast insert system, expansion anchors.
 2. Steel Structural Elements: Use beam clamps, or welded fasteners.
 3. Concrete Surfaces: Use self-drilling anchors or expansion anchors.
 4. Hollow Masonry, Plaster, and Gypsum Board Partitions: Use toggle bolts or hollow wall fasteners.
 5. Solid Masonry Walls: Use expansion anchors or preset inserts.
 6. Sheet Metal: Use sheet metal screws.
 7. Wood Elements: Use wood screws.
- C. Installation: Install products in accordance with manufacturer's instructions. Provide anchors, fasteners, and supports in accordance with NECA "Standard of Installation". Do not fasten supports to pipes, ducts, mechanical equipment, and conduit. Do not use spring steel clips and clamps. Do not use powder-actuated anchors. Do not drill or cut structural members. Fabricate supports from structural steel or steel channel. Rigidly weld members or use hexagon head bolts to present neat appearance with adequate strength and rigidity. Use spring lock washers under all nuts. Install surface-mounted cabinets and panelboards with a minimum of four anchors. In wet and damp locations use steel channel supports to stand cabinets and panelboards one inch off wall. Use sheet metal channels to bridge studs above and below cabinets and panelboards recessed in hollow partitions.

2.11 ELECTRICAL IDENTIFICATION

- A. Nameplates: Engraved three-layer laminated plastic, black letters on white background. Locations: Each electrical distribution and control equipment enclosure, communication cabinets. Letter Size: Use 1/8-inch letters for identifying individual equipment and loads. Use 1/4 inch letters for identifying grouped equipment and loads.
- B. Labels: Embossed adhesive tape, with 3/16-inch white letters on black background. Use for identification of individual power receptacle faceplates indicating panel & circuit number the outlet is fed from and control device stations. In addition to nameplates as described above, use labels on all panelboards, disconnect switches and enclosed circuit breakers to identify where the equipment is fed from, voltage & phase.
- C. Wire markers: Tape, or tubing type wire markers. Locations: Each conductor at panelboard gutters, pull boxes, outlet and junction boxes, and each load connection. Power and Lighting Circuits shall be

marked with panel and branch circuit, or feeder number as indicated on drawings. Control Circuits shall be marked with control wire number indicated on schematic and interconnection diagrams on drawings

- D. Conduit markers: Corrosion and abrasion resistant. Location: Furnish markers for each conduit longer than 6 feet (2 m). Spacing: 20 feet on-center. Indicate voltage and phase.
- E. All panelboards shall be provided with a typed (handwritten is not allowed) circuit directory indicating the load fed by each circuit breaker and its location in the building.

2.12 ENCLOSED SWITCHES

- A. Fusible Switch Assemblies shall be provided in accordance with the following. Description: NEMA KS 1, Type GD with externally operable handle interlocked to prevent opening front cover with switch in ON position, enclosed load interrupter knife switch. Handle lockable in OFF position. Fuse clips: Designed to accommodate NEMA FU1, Class R fuses. Provide NEMA 3R where located outdoors, kitchens or other interior wet areas.
- B. Non-fusible switch assemblies shall be provided in accordance with the following. Description: NEMA KS 1, Type GD with externally operable handle interlocked to prevent opening front cover with switch in ON position enclosed load interrupter knife switch. Handle lockable in OFF position. Provide NEMA 3R where located outdoors, kitchens or other interior wet areas.
- C. Install in accordance with NECA "Standard of Installation". Install fuses in fusible disconnect switches. Apply adhesive tag on inside door of each fused switch indicating NEMA fuse class and size installed.

2.13 PANELBOARDS

- A. Description: NEMA PB1, circuit breaker type, lighting, and appliance branch circuit panelboard.
- B. Panelboard Bussing: Bus bars shall be copper. Provide copper ground bus bar in all panelboards.
- C. Minimum Integrated Short Circuit Rating: 100,000 amperes RMS symmetrical for 240 volt panelboards; or as indicated.
- D. Molded Case Circuit Breakers: NEMA AB 1, bolt-on type thermal magnetic trip circuit breakers, with common trip handle for all poles, listed as Type SWD for lighting circuits, Type HACR for air conditioning equipment circuits, Class A ground fault interrupter circuit breakers where scheduled. Do not use tandem circuit breakers.
- E. Enclosure: NEMA PB 1, Type 1.
- F. Cabinet Box: 6 inches deep, 20 inches wide for 240 volt and less panelboards.
- G. Cabinet Front: Flush or Surface cabinet front as scheduled with concealed trim clamps, concealed hinge, metal directory frame, and flush lock all keyed alike. Finish in manufacturer's standard ANSI 49 enamel.

2.14 ENCLOSED CIRCUIT BREAKERS

- A. Enclosed Molded Case Circuit Breaker: Comply with NEMA AB 1. Include provisions for padlocking. Provide insulated grounding lug in each enclosure. Provide Products suitable for use as service entrance equipment where so applied. Fabricate enclosure from steel.
- B. Install enclosed circuit breakers where indicated, in accordance with manufacturer's instructions. Install enclosed circuit breakers plumb. Provide supports in accordance with these specifications. Height: 5 ft (1.6 M) to operating handle. Provide engraved plastic nameplates.
- C. Inspect each circuit breaker visually. Perform several mechanical ON-OFF operations on each circuit breaker. Verify circuit continuity on each pole in closed position. Determine that circuit breaker will trip on overcurrent condition, with tripping time to NEMA AB 1 requirements. Include description of testing and results in test report.

2.15 FUSES

- A. All fuses shall be rated for proper voltage in which they are applied. Interrupting ratings shall be greater than the short circuit current available at the terminals of the switch.

- B. Fuse types:
 - 1. Fuses for branch circuits shall be time delay class J.
 - 2. Fuses for equipment other than motor loads shall be general fast acting RK-5 or Class J.
 - 3. Control power transformers for motor controller circuits shall be as recommended by motor starter and motor control center manufacturer.
 - 4. Fuses for motors shall be sized at 250% of the motor FLA.
 - 5. Fuses for non-motor loads shall be sized at 125% of the rated FLA of equipment served.
 - 6. Fuses for elevator lifts shall be dual element type and sized in accordance with the elevator manufacturer's recommendations.
- C. Spare Fuses
 - 1. Provide spare fuses in the amount of 20% (not less than three (3) nor more than nine (9) of all sizes and types).
 - 2. Spare fuses shall include general purpose fuses, motor fuses, and control fuses used in motor control centers, starters etc.
 - 3. A complete list and quantity of spare fuses shall be submitted with record drawings for review.

2.16 ENCLOSED MOTOR CONTROLLERS

- A. The Electrical Contractor shall review the mechanical drawings and coordinate with the Mechanical Contractor for electrical components of the mechanical equipment and systems such as motors, factory mounted motor starters, factory mounted disconnect switches, variable frequency drives and controls to be provided under Division 15 (by the Mechanical Contractor).
- B. The Electrical Contractor shall provide motor starters, variable frequency drives and disconnect switches for equipment shown on the drawings where the Mechanical Contractor is not providing such equipment.
- C. The electrical contractor shall provide all power wiring for all HVAC equipment.
- D. Manual Motor Controller: NEMA ICS 2, AC general-purpose Class A manually operated, full-voltage controller with thermal overload elements on each phase, red pilot light, NO, NC auxiliary contact, and push button or toggle operator.
- E. Fractional Horsepower Manual Controller: NEMA ICS 2, AC general-purpose Class A manually operated, full-voltage controller for fractional horsepower induction motors, with thermal overload elements on each phase, red pilot light, and toggle operator.
- F. Motor Starting Switch: NEMA ICS 2, AC general-purpose Class A manually operated, full-voltage controller for fractional horsepower induction motors, without thermal overload elements on each phase, with red pilot light and toggle operator.
- G. Enclosures: NEMA ICS 6; Type 1 for indoors and Type 3R for outdoors and wet/damp locations (kitchens, mechanical rooms, pool equipment rooms, etc...).
- H. Automatic Magnetic Motor Controllers: NEMA ICS 2, AC general-purpose Class A magnetic controller for induction motors rated in horsepower. Reversing Controllers: Include electrical interlock and integral time delay transition between FORWARD and REVERSE rotation. Two Speed Controllers: Include integral time delay transition between FAST and SLOW speeds. Coil operating voltage: 120volts, 60 Hertz. Overload Relay: NEMA ICS; bimetal or melting alloy. Enclosure: NEMA ICS 6, Type 1 for indoors or Type 3R for outdoors and wet/damp locations (kitchens, mechanical rooms, pool equipment rooms, etc...).
- I. Product Options and Features as follows. Auxiliary Contacts: NEMA ICS 2, 2 each normally open and closed contacts in addition to seal-in contact. Cover Mounted Pilot Devices: NEMA ICS 2, standard duty type. Pilot Device Contacts: NEMA ICS 2, Form Z, rated A150. Pushbuttons: Recessed type. Indicating Lights: LED type. Selector Switches: Rotary type. Relays: NEMA ICS 2. Control Power Transformers: 120 volt secondary, in each motor starter. Provide fused primary and secondary, and bond un-fused leg of secondary to enclosure.
- J. Installation Requirements: Install enclosed controllers where indicated, in accordance with manufacturer's instructions. Install enclosed controllers plumb. Provide supports in accordance with these specifications. Height: 5 feet to operating handle. Install fuses in fusible switches. Select and install overload heater elements in motor controllers to match installed motor characteristics. Provide engraved plastic nameplates under these specifications. Provide neatly typed label inside each motor

controller door identifying motor served, nameplate horsepower, full load amperes, code letter, service factor, and voltage/phase rating.

2.17 ENCLOSED CONTACTORS

- A. General purpose contactors: NEMA ICS 2, AC general purpose magnetic contactor. Coil Voltage as indicated. Poles as indicated. Size as indicated. Enclosure per ANSI/NEMA ICS 6, Type as scheduled.
- B. Lighting contactors: NEMA ICS 2, magnetic lighting contactor. Coil Voltage as indicated. Poles as indicated. Size as indicated. Contact Rating shall match branch circuit overcurrent protection, considering de-rating for continuous loads.
- C. Accessories: Provide Pushbuttons and Selector Switches per NEMA ICS 2, heavy duty type. Provide indicating lights per NEMA ICS 2, push-to-test type. Provide auxiliary contacts per NEMA ICS 2, Class A300 or A600 as required per equipment served.

2.18 INTERIOR LUMINAIRES

- A. Lighting fixtures shall be in accordance with identifications as follows:
- B. All lamping shall be of the highest quality available.
- C. Finishes shall be as selected by the Architect or as indicated on the plans.
- D. Any additional appurtenances required for installation and operation, where same are not covered by the identification used on the drawings, shall be included. Lighting fixtures and equipment shall be furnished complete, wired and assembled, including canopies, lamps and other incidental items. Install specified lamps in each luminaire.
- E. Recessed fixtures shall be coordinated with ceiling construction by the Electrical Contractor prior to Bid. Refer to the Architect's plans, details and elevations for ceiling types by area. Provide plaster trim kits as required by ceiling construction.
- F. Exact location of all fixtures shall be confirmed with Architect prior to rough-in. Install surface mounted luminaires and exit signs plumb and adjust to align with building lines and with each other. Secure to prevent movement.
- G. Recessed fixtures throughout shall have their components, wiring and external connections coordinated for use in ceilings utilized as air handling plenums. Install recessed luminaires to permit removal from below. Install recessed luminaires using accessories and firestopping materials to meet regulatory requirements for fire rating. Install clips to secure recessed grid-supported luminaires in place
- H. Fixtures for use outdoors or in areas designated as damp locations, shall be suitably gasketed and UL listed for such applications.
- I. Make wiring connections to branch circuit using building wire with insulation suitable for temperature conditions within luminaire
- J. Emergency batteries for exterior fixtures shall be remote mounted within the building. Verify maximum distances for remote mounting the emergency batteries with the manufacturer prior to installation. Locate remote emergency batteries above accessible ceilings or utility rooms as required. Provide test switches for all emergency batteries as required.
- K. Unless noted otherwise, all fixtures shall be 3500K and have a minimum CRI of 85.
- L. The Contractor shall obtain all information relative to the exact type of hung ceilings and suspension systems to be installed before ordering any recessed fixtures. This Contractor shall furnish the proper type fixtures applicable to the ceiling framing system. If, other than the type of fixtures specified are required for installation due to the type of ceiling construction, this Contractor shall furnish and install the proper type fixtures and mounting appurtenances required at no extra charge.
- M. The Contractor shall coordinate the exact locations of all lighting fixtures with the ceiling pattern during the construction period and before installation of the fixtures. Interferences between lighting fixtures, and other equipment, shall be brought to the attention of the General Contractor.
- N. Include the aiming and/or adjustments of all lighting fixtures requiring same in accordance with instructions issued by the Architect in the field. Aim and adjust luminaries as indicated or as directed by the Owner, Architect or Engineer. Position exit sign directional arrows as indicated. Operate each luminaire after installation and connection. Ensure proper connection and operation.

- O. Lighting fixtures shall be supported from building structure only, not from hung or suspended ceiling, by means of chains or threaded rods. The use of tie wire will not be allowed. All fixtures shall include seismic clips and shall be supported to comply with seismic regulations. Install suspended luminaires using pendants supported from swivel hangers or other suitable leveling means. All rows of fixtures shall be level, aligned with building lines and run parallel to each other. Provide pendant length required to suspend luminaires at indicated height. Support luminaires to building structure, independent of ceiling framing.

2.19 FIRE ALARM SYSTEM

A. GENERAL

1. The contractor shall submit complete documentation for the Fire Alarm/Life Safety System Data Sheets for all items to ensure compliance with these specifications. Copies of this information shall be submitted as required to the Architect award of this work and shall be subject to the approval of the architect.
2. The contractor shall submit, as part of the complete bid documentation package, certification that the engineered system distributor is a fully authorized factory trained and certified distributor of the system detailed within this specification.
3. All equipment and material shall be new and unused, and listed by Underwriter's Laboratories for the specific intended purpose. All control panel components, field peripherals and interactive computer peripherals shall be designed for continuous duty operation without degradation of function or performance.
4. All equipment covered by this specification or noted on installation drawings shall be the best equipment suited for the application and shall be provided by a single manufacturer.
5. Provide all equipment and accessories and compatible devices for a complete and fully functioning fire alarm system. The fire alarm system shall be coordinated with and inspected by the local fire department, and any inconsistency mentioned during any inspection shall be corrected by contractor at no additional cost to owner.
6. Verify color of devices and wall plates, either white with red letters or red with white letters, with the Architect prior to ordering any material.
7. The control panel shall contain a microprocessor with 10/100 ethernet media access controller (MAC). The system shall be designed specifically for emergency voice evacuation, fire detection, and notification applications.
8. The installing contractor shall coordinate master-box, radio-box, and/or dialer requirements with local fire department.
- 9.

B. FIRE ALARM LIFE SAFETY SYSTEM SEQUENCE OF OPERATION

1. The operation of a manual station or activation of any automatic alarm initiating device (system smoke, heat, waterflow) in the building, shall automatically:
 - a. Initiate the transmission of the alarm to the Municipal Fire Station or approved Central Station via the Local Energy or Radio Master-box where required by Code.
 - b. Sound a code 3 temporal evacuation signal over all audible circuits.
 - c. Flash all visual signals throughout the building in a synchronized manner.
 - d. Flash an alarm LED and sound an audible signal at the FACP. Upon acknowledgement, the alarm LED shall light steadily and the audible shall silence. Subsequent alarms shall re-initiate this sequence.
 - e. Upon alarm initiation by an elevator lobby smoke detector or other designated recall device, recall all elevators that serve the floor of initialization to the main egress level. If the alarm initiates on the main egress level, return the elevator to the alternate floor as directed by the local authority having jurisdiction.
 - f. Visually indicate the alarm initiating device type and location via the LCD display located at the FACP (and at any remote annunciators) and (illuminate the appropriate alarm zone LED at the remote annunciator).

- g. Automatically shut down or control HVAC equipment to initiate smoke control functions as required. Manual override controls and programmable relay interface shall serve as an interface to the Building Automation System.
- h. Operate prioritized outputs to release all magnetically held smoke doors and magnetically locked doors throughout the building.
- i. Activate the exterior weatherproof beacon.
- a. Sound a code 4 temporal and voice evacuation signal for carbon monoxide to all alarm devices within the apartment.

C. WIRING

- 1. Provide in accordance with manufacturer's instructions all wiring, conduit and outlet boxes required for the installation of complete system as described herein and as shown on the drawings. Wiring shall be Class A.
- 2. Installation and fire alarm system wiring shall be installed in metal raceway. An equipment bonding conductor shall be provided in all flexible metallic raceways.
- 3. Color code for fire alarm systems shall be per the State Fire Alarm code.
- 4. DC supply to the main fire alarm panel shall be white and black. Fire alarm primary power source shall be on dedicated branch circuit. Circuit breaker locks shall be used. If a separate feed is required for the battery charger it shall be black and white unless the main fire alarm panel required only AC feed. In this case the conductors to the battery charger shall be red and white and shall be on a circuit breaker of fits own.
- 5. Conductors shall be minimum #14-gauge solid copper type THHN/THWN. Conductor's size shall be increased as required to maintain voltage drop to a maximum of 3%. All AC and DC portions of the system shall be installed in separate raceway. Addressable loop wiring may be #16 providing manufacturer's recommended distance is observed. Systems requiring shielded wiring for addressable loops shall not be acceptable.
- 6. Red painted terminal cabinets with hinged local covers shall be provided at all junction points. All conductor splices shall be made on screw type terminal blocks, wire nuts shall not be used. All terminals within terminal cabinets shall be properly labeled. Provide terminal cabinets at each building cable entrance and at other locations as required.
- 7. All fire alarm initiating zone and signal wiring shall be wired Class A.
- 8. Final connections between the equipment and the wiring system shall be made under the direct supervision of a representative of the manufacturer.
- 9. Upon completion of the installation of fire alarm equipment, the electrical contractor shall provide to the engineer a signed statement substantially in the form as follows:
 - a. The undersigned having been engaged as the electrical contractor on this project confirms the fire alarm equipment was installed in accordance with the specifications and in accordance with wiring diagrams, instructions, and directions provided to us by the manufacturer.

D. GUARANTEE AND FINAL TEST

- 1. All testing (pre-testing, final testing, quarterly testing and program change testing) to be coordinated with the owner and scheduled in advance so that owners and personnel can be present during testing. Contractor to certify that all tests comply with the "State Fire Code", latest edition.
- 2. Before this installation shall be considered complete and acceptable to the awarding authorities, a complete test on the system shall be performed as follows:
 - a. A pre-test will be held by the electrical contractor with the manufacturer's authorized representative present. After certification of a complete pre-test, the installing contractor shall inform the authority having jurisdiction of the outcome of the test and will re-inspect in the presence of the authority having jurisdiction and the manufacturer's authorized representative.
 - b. Final test: The electrical contractor in the presence of authorized representative of the manufacturer and the fire department shall operate every manual station, smoke detector, and thermal detector. Each station/detector circuit and horn circuit shall be opened in at least two locations to check for the presence of correct supervisory circuitry. When this testing has been completed to the satisfaction of both the electrical contractor's job foreman and the representative of the manufacturer, a letter from the contractor cosigned by the manufacturer attesting to the satisfactory completion of said testing, shall be forwarded to the owner.
- 3. The electrical contractor shall guarantee all equipment and wiring to be free from inherent mechanical and electrical defects for a period of one year from the date of final acceptance.

4. The contractor shall provide the Owner with a formal written equipment guarantee upon completion of the installation and testing of the system. The guarantee period shall begin on the day of acceptance of the system by the Owner and shall provide for a period of one year. This guarantee shall be indicated in the manufacturer's submission prior to approval. This guarantee shall be as normal policy by the equipment manufacturer.
5. The manufacturer shall maintain a full-time service and parts facility, with seven days per week, 24 hour per day service available.
6. All service technicians shall be licensed by the State Fire Code covering service and maintenance of systems.
7. Include as part of the contract, the four quarterly tests following the final acceptance test. Provide quarterly testing in conformance with the State Fire Code latest addition.

2.20 DATA

- A. Service: Provide incoming data (internet) service raceways and cable as required by the Owner's representative and/or vendor or as required by the serving internet company from the utility pole to the building. Provide ¾" plywood board (and one double duplex outlet) in weather-proof cabinet for internet service equipment. Provide a ¾-inch-thick plywood board (8'-0" wide by 4'-0" high) inside of building. All plywood backboards shall be fire-retardant-treated and stamped FRT, securely anchored to the cabinet or wall. Provide a copper ground bar (1/4" thick x 4" high x 36" long) with wall mounting brackets, insulators and a #6AWG copper exothermically welded pigtail in each data cabinet or wall. Connect pig tail to building electrical service grounding system per the internet company's requirements.
- B. The Electrical Contractor shall provide and install data outlet backbox per the Owner's specifications and direction. Install ¾" EMT conduit with pull string from backbox to above accessible ceiling. Provide bushed endcap on conduit (above ceiling end of conduit).

2.21 TELEPHONE

- A. Service: Provide incoming telephone service raceways and cable as required by the Owner's representative and/or vendor or as required by the serving telephone company from the utility pole to the building. Provide ¾" plywood board (and one double duplex outlet) in weather-proof cabinet for telephone service equipment. Provide a ¾-inch-thick plywood board (8'-0" wide by 4'-0" high) inside of building. All plywood backboards shall be fire-retardant-treated and stamped FRT, securely anchored to the cabinet or wall. Provide a copper ground bar (1/4" thick x 4" high x 36" long) with wall mounting brackets, insulators and a #6AWG copper exothermically welded pigtail in each telephone cabinet or wall. Connect pig tail to building electrical service grounding system per the telephone company's requirements.
- B. The Electrical Contractor shall provide and install data outlet backbox per the Owner's specifications and direction. Install ¾" EMT conduit with pull string from backbox to above accessible ceiling. Provide bushed endcap on conduit (above ceiling end of conduit).

2.22 CABLE TELEVISION

- A. Service: Provide incoming CATV service raceways and cable as required by the Owner's representative and/or vendor or as required by the serving CATV company from the utility pole to the building. Provide ¾" plywood board (and one double duplex outlet) in weather-proof cabinet for CATV service equipment. Provide a ¾-inch-thick plywood board (8'-0" wide by 4'-0" high) inside of building. All plywood backboards shall be fire-retardant-treated and stamped FRT, securely anchored to the cabinet or wall. Provide a copper ground bar (1/4" thick x 4" high x 36" long) with wall mounting brackets, insulators and a #6AWG copper exothermically welded pigtail in each CATV cabinet or wall. Connect pig tail to building electrical service grounding system per the CATV company's requirements.

- B. The Electrical Contractor shall provide and install CATV outlet backbox per the Owner's specifications and direction. Install ¾" EMT conduit with pull string from backbox to above accessible ceiling. Provide bushed endcap on conduit (above ceiling end of conduit).

2.23 PACKAGE GENERATOR SET

A. References and Standards

The generator set covered by these specifications shall be designed, tested, rated, assembled and installed in strict accordance with all applicable standards below:

- CSA C22.2 No14
- CSA 282
- CSA 100
- EN61000-6
- EN55011
- FCC Part 15 Subpart B
- ISO8528
- IEC61000
- UL508
- UL2200
- UL142
- Designed to allow for installed compliance to NFPA 70, NFPA99 and NFPA 110

- B. Installation: The work includes supplying and installing a complete integrated generator system. The system consists of a generator set with related component accessories and automatic transfer switches.

- C. Fuel System: This CONTRACTOR shall provide a full tank of diesel fuel for the completion of all testing.

- D. System Test: A complete system load test shall be performed after all equipment is installed. Guidelines in the Start-up Section.

- E. Requirements, Codes and Regulations: The equipment supplied and installed shall meet the requirements of the NEC and all applicable local codes and regulations. All equipment shall be of new and current production by a MANUFACTURER who has 25 years of experience building this type of equipment. Manufacturer shall be ISO9001 certified.

- F. Substitution: Proposed deviations from the specifications shall be treated as follows:

1. Substitution Time Requirement: Requests for substitutions shall be made a minimum of ten (10) days prior to bid date. Manufacturers catalog data shall accompany each request and authorized acceptance shall be addenda only.

2. Substitution Responsibility: The power system has been designed to the specified manufacturer's electrical and physical characteristics. The equipment sizing, spacing, amounts, electrical wiring, ventilation equipment, fuel and exhaust components have all been sized and designed around CATERPILLAR supplied equipment. Should any substitutions be made, the CONTRACTOR shall bear responsibility for the installation, coordination and operation of the system as well as any engineering and redesign costs, which may result from such substitutions.

- G. Submittals: Engine-generator submittals shall include the following information:

1. Factory published specification sheet.
2. Manufacturer's catalog cut sheets of all auxiliary components such as battery charger, control panel, enclosure, etc.
3. Dimensional elevation and layout drawings of the generator set, enclosure and transfer switchgear and related accessories.

4. Weights of all equipment.
 5. Concrete pad recommendation, layout and stub-up locations of electrical and fuel systems.
 6. Interconnect wiring diagram of complete emergency system, including generator, switchgear, day tank, remote pumps, battery charger, control panel, and remote alarm indications.
 7. Engine mechanical data, including heat rejection, exhaust gas flows, combustion air and ventilation air flows, fuel consumption, etc.
 8. Generator electrical data including temperature and insulation data, cooling requirements, excitation ratings, voltage regulation, voltage regulator, efficiencies, waveform distortion and telephone influence factor.
 9. Generator resistances, reactances and time constants.
 10. Generator locked rotor motor starting curves.
 11. Manufacturer's and dealer's written warranty.
- H. System Responsibility: The completed engine generator set shall be supplied by the Manufacturer's authorized distributor only. The Generator Distributor shall have an ISO 9002 Certified Quality Program in order to be considered as an acceptable supplier. Details of the Quality Certification shall be included with the Approval Submittal Documentation.
- I. Requirements, Codes and Regulations: The equipment supplied and installed shall meet the requirements of NEC and all-applicable local codes and regulations. All equipment shall be new, of current production. There shall be one source responsibility for warranty; parts and service through a local representative with factory trained service personnel.
- J. Automatic Transfer Switch: The automatic transfer switches specified shall be provided by this contractor and supplied by the generator set manufacturer in order to establish and maintain a single source of system responsibility and coordination.
- K. Warranty: Two Year Standby (ISO 8528-1: ESP) Generator Set and Automatic Transfer switches. The manufacturer's standard warranty shall in no event be for a period of less than two (2) years from date of initial start-up of the system and shall include repair parts, labor, reasonable travel expense necessary for repairs at the job site, and expendables (lubricating oil, filters, antifreeze, and other service items made unusable by the defect) used during the course of repair. Running hours shall be limited to 500 hours annually for the system warranty by both the manufacturer and servicing distributor. Submittals received without written warranties as specified will be rejected in their entirety.
- L. Service Facility: The engine-generator supplier shall maintain 24-hour parts and service capability within 100 miles of the project site. The distributor shall stock parts as needed to support the generator set package for this specific project. The supplier must carry sufficient inventory to cover no less than 80% parts service within 24hrs and 95% within 48 hours. The dealer shall maintain qualified factory trained service personnel.
- M. Genset Requirements: The generator set shall be Standby Duty rated, 1800 RPM, 0.8 power factor, 208Y/120volts, 3-phase, 4-wire, 60 hertz, including radiator fan and all parasitic loads. Generator set shall be sized to operate at the specified load at a maximum ambient of 85F (29.4C) and altitude of 500.0 feet (152.4 m).
- Standby Rating as defined by the following:
Typical Load Factor = 70% or less with variable load.
Typical Hours per Year = 200 hours.
Maximum Expected Usage = 500 hours/year.
Typical Peak Demand = 80% of ESP rated kW with 100% of rating available for the duration of an emergency outage.
- N. Material and Parts: All materials and parts comprising the unit shall be new and unused.

- O. Engine: The engine shall meet applicable EPA non-road mobile regulations and/or the EPA NSPS rule for stationary reciprocating compression ignition engines. Additionally, the engine shall comply with the State Emission regulations at the time of installation/commissioning. Actual engine emissions values must be in compliance with applicable EPA emissions standards per ISO 8178 - D2 Emissions Cycle at specified kW / bHP rating. Utilization of the "Transition Program for Equipment Manufacturers" (also known as "Flex Credits") to achieve EPA certification is not acceptable. The in-cylinder engine technology must not permit unfiltered exhaust gas to be introduced into the combustion cylinder. Emissions requirements / certifications of this package: EPA TIER 3
- P. Engine Governing: The engine will be equipped with an isochronous electronic governor to maintain +/- 0.25% steady state frequency variation from steady state no load to steady state full load.
- Q. Generator Specifications: The synchronous three phase generator shall be a single bearing, self-ventilated, drip-proof design in accordance with NEMA MG 1 and directly connected to the engine flywheel housing with a flex coupling. The generator shall meet performance class G3 of IEC. The excitation system shall be of brushless construction.
- R. Automatic Voltage Regulator: The automatic voltage regulator (AVR) shall maintain generator output voltage within +/- 1% for any constant load between no load and full load. The regulator shall be a totally solid-state design, which includes electronic voltage buildup, volts per Hertz regulation, over-excitation protection, shall limit voltage overshoot on startup, and shall be environmentally sealed.
- S. Motor Starting: Provide locked rotor motor starting ratings at 30% instantaneous voltage dip as defined per NEMA MG
- T. Circuit Breaker: Provide a generator mounted circuit breaker or panelboard with breakers as required by manufacturer, ratings as shown on drawings, molded case, 3 pole, NEMA 1/IP22. Breaker shall be housed in an extension terminal box which is isolated from vibrations induced by the generator set. Mechanical type lugs, sized for the circuit breaker feeders shown on drawing, shall be supplied on the load side of breaker.
- U. Controls – Generator Set Mounted: Provide a fully solid-state, microprocessor based, generator set control. The control panel shall be designed and built by the engine manufacturer. The control shall provide all operating, monitoring, and control functions for the generator set. The control panel shall provide real time digital communications to all engine and regulator controls via SAE J1939.
- V. Environmental: The generator set control shall be tested and certified to the following environmental conditions.
 - 1. -40°C to +70°C Operating Range
 - 2. 95% humidity non-condensing, 30°C to 60°C
 - 3. IP22 protection
 - 4. 5% salt spray, 48 hours, +38°C, 36.8V system voltage
 - 5. Sinusoidal vibration 4.3G's RMS, 24-1000Hz
 - 6. Electromagnetic Capability (89/336/EEC, 91/368/EEC, 93/44/EEC, 93/68/EEC, BS EN 50081-2, 50082-2)
 - 7. Shock: withstand 15G
- W. Functional Requirements: The following functionality shall be integral to the control panel.
 - 1. The control shall include a 33 x 132 pixel, 24mm x 95mm, positive image, transfective LCD display with text based alarm/event descriptions.
 - 2. Audible horn for alarm and shutdown with horn silence switch
 - 3. Standard ISO labeling
 - 4. Multiple language capability

5. Remote start/stop control
 6. Local run/off/auto control integral to system microprocessor
 7. Cooldown timer
 8. Speed adjust
 9. Lamp test
 10. Push button emergency stop button
 11. Password protected system programming
- X. Digital Monitoring Capability: The controls shall provide the following digital readouts for the engine and generator. All readings shall be indicated in either metric or English units.
- Engine:
1. Engine oil pressure
 2. Engine oil temperature
 3. Engine coolant temperature
 4. Engine RPM
 5. Battery volts
- Generator:
1. Generator AC volts (Line to Line, Line to Neutral and Average)
 2. Generator AC current (Avg and Per Phase)
 3. Generator AC Frequency
 4. Generator kW (Total and Per Phase)
 5. Generator kVA (Total and Per Phase)
 6. Generator kVAR (Total and Per Phase)
 7. Power Factor (Avg and Per Phase)
 8. Total kW-hr
 9. Total kVAR-hr
 10. % kW
 11. % kVA
 12. % kVAR
- Y. Alarms and Shutdowns: The control shall monitor and provide alarm indication and subsequent shutdown for the following conditions. All alarms and shutdowns are accompanied by a time, date, and engine hour stamp that are stored by the control panel for first and last occurrence:
- Engine Alarm/Shutdown:
1. Low oil pressure alarm/shutdown
 2. High coolant temperature alarm/shutdown
 3. Loss of coolant shutdown
 4. Overspeed shutdown
 5. Overcrank shutdown
 6. Low coolant level alarm
 7. Low fuel level alarm
 8. Emergency stop depressed shutdown
 9. Low coolant temperature alarm
 10. Low battery voltage alarm
 11. High battery voltage alarm
 12. Control switch not in auto position alarm
 13. Battery charger failure alarm
- Generator Alarm/Shutdown:
1. Generator Over Voltage
 2. Generator Under Voltage
 3. Generator Over Frequency
 4. Generator Under Frequency
 5. Generator Reverse Power
 6. Generator Overcurrent

- Z. Inputs and Outputs:
 - 1. Programmable Digital Inputs:

The Controller shall include the ability to accept six (6) digital input signals. The signals may be programmed for either high or low activation using programmable Normally Open or Normally Closed contacts.
 - 2. Digital Outputs:

The control shall include the ability to operate six (6) programmable relay output signals, integral to the controller. The output relays shall be rated for 2A @ 30VDC.
 - 3. Discrete Outputs:

The control shall include the ability to operate one (1) discrete outputs, integral to the controller, which are capable of sinking up to 300mA.

- AA. Maintenance: All engine, voltage regulator, control panel and accessory units shall be accessible through a single electronic service tool. The following maintenance functionality shall be integral to the generator set control:
 - 1. Engine running hours display
 - 2. Service maintenance interval (running hours or calendar days)
 - 3. Engine crank attempt counter
 - 4. Engine successful starts counter
 - 5. 20 events are stored in control panel memory
 - 6. Programmable cycle timer that starts and runs the generator for a predetermined time. The timer shall use 14 user-programmable sequences that are repeated in a 7-day cycle. Each sequence shall have the following programmable set points:
 - a. Day of week
 - b. Time of day to start
 - c. Duration of cycle

- BB. Remote Annunciation: (NFPA 99/110, CSA 282) Provide a remote annunciator to meet the requirements of NFPA 110, Level 1.
 - 1. The annunciator shall provide remote annunciation of all points stated above and shall incorporate ring-back capability so that after silencing the initial alarm, any subsequent alarms will sound the horn.
 - 2. Ability to be located up to 800 ft from the generator set

- CC. Cooling System: The generator set shall be equipped with a rail-mounted, engine-driven radiator with blower fan and all accessories. The cooling system shall be sized to operate at full load conditions and 110 F* ambient air entering the room or enclosure (If an enclosure is specified). The generator set supplier is responsible for providing a properly sized cooling system based on the enclosure static pressure restriction.

- DD. Fuel System: diesel.

- FF. Starting System: (Starting Motor) A DC electric starting system with positive engagement shall be furnished. The motor voltage shall be as recommended by the engine manufacturer.

- GG. Jacket Water Heater: Jacket water heater shall be provided and shall be sized to insure that genset will start within the specified time period and ambient conditions.

- HH. Batteries: A lead-acid storage battery set of the heavy-duty diesel starting type shall be provided. Battery voltage shall be compatible with the starting system.

- II. Battery Charger: A current limiting battery charger shall be furnished to automatically recharge batteries. The charger shall be dual charge rate with automatic switching to the boost rate when required. The battery charger shall be mounted on the genset package or inside the genset enclosure/room.

- JJ. Sound Attenuated Enclosure: The complete diesel engine generator set, including generator control panel, engine starting batteries and fuel oil tank, shall be enclosed in a factory assembled, sound attenuated enclosure mounted on the fuel tank base.
1. A weather resistant, sound attenuated enclosure of steel with electrostatically applied powder coated baked polyester paint. The enclosure shall have a resulting sound level no greater than 69 dba @ 23 ft with the genset running under full load. It shall consist of a roof, side walls, and end walls. Fasteners shall be either zinc plated or stainless steel.
2. Enclosure Sound Attenuation: Acoustical foam shall be provided between all supports and inside doors and sound baffles on air intake and air discharge.
- KK. Installation: Install equipment in accordance with manufacturer's recommendations, the project drawings and specifications, and all applicable codes.
- LL. Start-Up and Testing: Coordinate all start-up and testing activities with the Engineer and Owner. After installation is complete and normal power is available, the manufacturer's local dealer shall perform the following: Perform a 4-hour load bank test at a 1.0 PF at full nameplate rating. Loadbank, cables and other equipment required for this test to be supplied by the genset supplier.
- MM. Operation and Maintenance Manuals: Provide two (2) sets of operation and maintenance manuals covering the generator, switchgear, and auxiliary components. Include final as-built wiring interconnect diagrams and recommended preventative maintenance schedules.
- NN. Training: Provide on-site training to instruct the owner's personnel in the proper operation and maintenance of the equipment. Review operation and maintenance manuals, parts manuals, and emergency service procedures.

2.24 AUTOMATIC TRANSFER SWITCH

- A. It is the intent of this specification to secure a transfer switch that has been prototype tested, factory built, production tested and site tested. A transfer switch with the number of poles, voltage and current ratings shown on the plans and specified herein shall be provided.
- B. Codes and Standards: The automatic transfer switch shall conform to the requirements of:
1. UL 1008: Underwriters Laboratories standard for automatic transfer switches
 2. CSA: C22.2 No. 178 certified
 3. IEC: 947-6-1 certified at 480 VAC
 4. NFPA 70: National Electrical Code including use in emergency and standby systems in accordance with Articles 517, 700, 701, 702
 5. NFPA 99: Essential electrical systems for health care facilities
 6. NFPA 101: Life safety code
 7. NFPA 110: Standard for emergency and standby power systems
 8. IEEE 241: I.E.E.E. recommended practice for electrical power systems in commercial buildings
 9. IEEE 446: I.E.E.E. recommended practice for emergency and standby power systems
 10. NEMA ICS10: AC automatic transfer switch equipment
 11. UL 50/508: Enclosures
 12. ICS 6: Enclosures
 13. ANSI C33.76: Enclosures
 14. NEMA 250: Enclosures
 15. IEEE 472: (ANSI C37.90A): Ringing wave immunity
 16. EN55022 (CISPR11): Conducted and radiated emissions (Exceeds EN55011 & MILSTD 461 Class 3)
 17. EN61000-4-2: (Level 4): ESD immunity test Class B:
 18. EN61000-4-3: (ENV50140): Radiated RF, electromagnetic field immunity

19. EN61000-4-4: Electrical fast transient/burst immunity test
 20. EN61000-4-5: IEEE C62.41: Surge immunity test (1.2 x 50µs, 5 & 8 kV)
 21. EN61000-4-6: (ENV50141): Conducted immunity test
 22. EN61000-4-11: Voltage dips and interruption immunity
- C. Approved Manufacturers: The automatic transfer switch shall be Russelectric, ASCO or Caterpillar. Alternate manufactures shall submit a request two weeks prior to bid and include a written list of deviations from this specification to be considered for approval.
- D. Performance and Construction:
1. The automatic transfer switch shall be of double throw construction operated by a reliable solenoid driven mechanism. There shall be a direct mechanical coupling to facilitate transfer in 6 cycles or less.
 2. The normal and emergency contacts shall be mechanically interlocked such that failure of any coil or disarrangement of any part shall not permit a neutral position.
 3. For switches installed in systems having ground fault protective devices, and/or wired so as to be designated a separately derived system by the NEC, a 4th pole shall be provided. This additional pole shall isolate the normal and emergency neutrals. The neutral pole shall have the same withstand and operational ratings as the other poles and shall be arranged to break last and make first to minimize neutral switching transients. Add-on or accessory poles that are not of identical construction and withstand capability will not be considered.
 4. The contact structure shall consist of a main current carrying contact, which is a silver alloy with a minimum of 50% silver content. The current carrying contacts shall be protected by silver tungsten arcing contacts on all sizes above 400 Amps.
 5. The transfer switch manufacturer shall submit test data for each size switch, showing it can withstand fault currents of the magnitude and the duration necessary to maintain the system integrity. Minimum UL listed withstand and close into fault ratings shall be 100,000.
 6. A dielectric test at the conclusion of the withstand and closing tests shall be performed.
 7. The automatic transfer switch manufacturer shall certify sufficient arc interrupting capabilities for 50 cycles of operation between a normal and emergency source that are 120 degrees out of phase at 480 volts, 600% of rated current at .50 power factor. This certification is to ensure that there will be no current flow between the two isolated sources during switching.
 8. All relays shall be continuous duty industrial type with wiping contacts. Coils, relays, timers and accessories shall be readily front accessible. The control panel and power section shall be interconnected with a harness and keyed disconnect plugs for maintenance.
 9. Main and arcing contacts shall be visible without major disassembly to facilitate inspection and maintenance.
 10. A manual handle shall be provided for maintenance purposes with the switch de-energized. An operator disconnect switch shall be provided to defeat automatic operation during maintenance, inspection or manual operation.
 11. Switches composed of molded case breakers, lighting contactors or components thereof will not be acceptable.

12. The current rating shall be a continuous rating when the switch is installed in an enclosure, and shall conform to NEMA temperature rise standards.
 13. The unit shall be rated based on all classes of loads, i.e., resistive, tungsten, ballast and inductive loads. Switches rated 400 amperes or less shall be UL listed for 100% tungsten lamp load.
 14. Temperature rise tests in accordance with UL 1008 shall have been conducted after the overload and endurance tests to confirm the ability of the units to carry their rated currents within the allowable temperature limits.
 15. Unless specified otherwise on the drawings, the switch shall be mounted in a NEMA 3R enclosure.
- E. Control:
1. The control panel shall be isolated from electrical noise and provided with the following inherent control functions and capabilities:
 2. The transfer switch shall be equipped with a microprocessor based control panel. The control panel shall perform the operational and display functions of the transfer switch. The display functions of the control panel shall include ATS position, source availability, sequence indication and diagnostics.
 3. All programmable and control functions shall be pass code protected and accessible through the keypad.
 4. The control panel shall be provided with a simple user interface for transfer switch monitoring, control and field changeable functions and settings.
 5. Touch pad test switch with Fast Test/Load/No Load selection capability to simulate a normal source failure.
 6. The controller shall provide digital timer adjustments with 1-second resolution. Voltage and Frequency shall be adjustable to 1% resolution to facilitate accurate transfer.
 7. To ensure reliable and consistent user operation the controls must be equipped with nonvolatile memory and allow automatic daylight savings time adjustment.
- F. Sequence of Operation:
1. The ATS shall incorporate adjustable three phase under voltage sensing on the normal source.
 2. When the voltage of any phase of the normal source is reduced to 80% (adjustable) of nominal voltage, for a period of 0-10 seconds (programmable) a pilot contact shall close to initiate starting of the engine generator.
 3. The ATS shall incorporate adjustable under voltage and under frequency sensing on the emergency source.
 4. When the emergency source has reached a voltage value of 90% of nominal and achieved frequency within 95% of the rated value, the load shall be transferred to the emergency source after a programmable time delay.
 5. When the normal source has been restored to not less than 90% of rated voltage on all phases, the load shall be retransferred to the normal source after a time delay of 0 to 60 minutes (programmable). The generator shall run unloaded for 5 minutes (programmable) and then automatically shut down. The generator shall be ready for automatic operation upon the next failure of the normal source.

6. If the engine generator should fail while carrying the load, retransfer to the normal source shall be made instantaneously upon restoration of proper voltage (90%) on the normal source.

G. Standard Accessories:

1. Adjustable time delay to override momentary normal source failure prior to engine start. Field programmable 0-10 seconds factory set at 3 seconds.
 2. Adjustable time delay on retransfer to normal source, programmable 0-60 minutes factory set at 30 minutes. If the emergency source fails during the retransfer time delay, the transfer switch controls shall automatically bypass the time delay and immediately retransfer to the normal position.
 3. A time delay on transfer to emergency, programmable 0-5 minutes, factory set at 1 second.
 4. An in-phase monitor shall be provided. The monitor shall compare the phase angle difference between the normal and emergency sources and be programmed to anticipate the zero crossing point to minimize switching transients.
 5. An exerciser timer with momentary test pushbutton shall be incorporated within the microprocessor and shall be capable of starting the engine generator set and transferring the load (when selected) for exercise purposes on a daily, weekly or monthly basis. The exerciser shall contain a battery for memory retention during an outage.
 6. Provide a momentary pushbutton to bypass the time delays on transfer and retransfer and programmable commit/no commit control logic.
 7. The controller shall accept a remote peak shave or test input to signal the transfer switch to the emergency position.
 8. A set of customer contacts shall be provided to indicate both emergency and normal source position.
- H. Factory Tests: The transfer switch manufacturer shall perform a complete functional test on the switch, controller and accessories prior to shipping from the factory. A certified test report shall be available upon request.
- I. Service: The manufacturer shall maintain a national service organization that is factory trained and certified for transfer switch equipment. In addition, the service organization shall be available 24 hours per day, 365 days per year.
- J. Warranty: The automatic transfer switch shall be warranted against defective workmanship for a period of two years from the date of startup of the generator set, and shall be comprehensive including both parts and labor.

2.25 EMERGENCY RESPONDER RADIO ANTENNA / REPEATER SYSTEM

1. SUMMARY

- A. Furnish, install, and test a complete and operating Emergency Responder Radio Antenna/Repeater System. The system shall support only the Fire Department radio system. Provisions for supporting other public safety systems (e.g. police); cell phone carriers; the Owners' private security and/or maintenance personnel radio systems, etc. shall not be included.
- B. This Section includes the requirements for an Emergency Responder Radio Antenna/Repeater System for the purposes of amplifying Emergency Responder radio signals to achieve the required signal strength in all areas on each floor of the building per the fire department.

- C. Final acceptance and approval is required from the local Fire Department in writing prior to contract closeout.
 - D. Section Includes
 - 1. Bi-directional amplifiers (BDA's)
 - 2. Distributed Antenna System
 - 3. Coaxial cables
 - 4. Splitters and direction couplers
 - 5. UPS and surge protection
 - 6. All other equipment and components necessary for a complete and functioning
2. REGULATIONS
- A. Codes, regulations, and standards referenced in the Section are:
 - 1. NFPA 1 – The National Fire Code (including Annex O from 2009)
 - 2. NFPA 70 – The National Electrical Code
 - 3. State and Local Fire Codes for Emergency Responder Radio Coverage
 - 4. NFPA 101, Life Safety Code.
 - 5. NFPA 72-07 National Fire Alarm Code
 - 6. FCC 47 CFR Private Land Mobile Radio
 - 7. 90.219-2007 Services-Use of Signal Boosters
 - 8. ICC International Fire Code, Code and Commentary
 - 9. ADA "Americans with Disabilities Act"
 - 10. FCC's OET 65 Standards "Guidelines for Human Exposure to Radio Frequency Electromagnetic Fields".
 - 11. FCC Rules Part 22, Part 90 and Part 101.
3. DEFINITIONS
- A. Definitions:
 - 1. Bi-Directional Amplifier BDA: Device used to amplify band-selective or multi-band RF signals in the uplink, to the base station for enhanced signals and improved coverage.
 - 2. Emergency Responder Radio Coverage System: A two-way radio communication system installed to assure the effective operation of radio communications systems for fire, emergency medical services or law enforcement agencies within a building or structure. A system used by firefighters, police, and other emergency services personnel.
 - 3. Delivered Audio Quality Definitions (DAQ): This is a universal standard often cited in system designs and specifications.
 - a. DAQ 1: Unusable, speech present but unreadable.
 - b. DAQ 2: Understandable with considerable effort. Frequent repetition due to noise/distortion.
 - c. DAQ 3: Speech understandable with slight effort. Occasional repetition required due to noise/distortion.
 - d. DAQ 3.5: Speech understandable with repetition only rarely required. Some noise/distortion
 - e. DAQ 4: Speech easily understood. Occasional noise/distortion.
 - f. DAQ 4.5: Speech easily understood. Infrequent noise/distortion.
 - g. DAQ 5: Speech easily understood. Coupled Bonding Conductor (CBC) – The term "Coupled Bonding Conductor" shall mean a bonding conductor placed, e.g. strapped, on the outside of any technology cable, used to suppress transient noise.
 - 4. FCC: Federal Communications Commission
 - 5. OET 65 Standards: FCC's Bulletin 65 provides Guidelines for Human Exposure to Radio Frequency Electromagnetic Fields.
 - 6. Public Safety/First Responder: Public Safety or First Responder agencies which are charged with the responsibility of responding to emergency situations. These include, but are not limited to law enforcement departments, fire departments, and emergency medical companies.
4. SUBMITTALS
- A. Submit product data for each type of proposed system component specified, including dimensioned drawings showing minimum clearances and installed features to the local fire department, Architect and Engineer prior to supplying any material for review and approval.
 - B. Layout Drawings
 - 1. Component specification sheets shall be 8.5-inch x 11 inch or greater, scaled or dimensioned, with dimensions or scale clearly noted.

2. Floor plan drawings shall be 24-inch x 36 inch minimum with drawings scaled to legible size.
 3. Floor plan drawings may include elevation detail names for each elevation view. Sheet title shall include site name, address, sheet number, floor plan number and north arrow. Include site plan view of the subject buildings and surrounding property to clearly indicate the location and orientation of roof mounted outdoor antennas associated with the proposed system.
 4. Include a minimum of (1) building elevation depicting the location of any outdoor antennas associated with the proposed system. Include height of antenna centerline above building, orientation, and location of all external grounding connections.
 5. Include a detail plan view of all Telecommunications Spaces housing head-end and/or other consolidated equipment, showing the location of the rack(s) and/or enclosure(s) of the Emergency Responder Radio Antenna/Repeater System equipment.
 6. Include a separate plan view of each interior floor where indoor antenna systems are proposed. Include antenna numbers, coaxial cable routes, and the locations of any other system components including splitters, couplers, filters, amplifiers, etc. All components shall be named or labeled for reference in power budget calculations tables. Overlay approximated coverage radii indicating -95 dBm downlink (base to mobile) signal strength around each proposed indoor coverage antenna. Include results of any previous coverage testing per grid, if available.
 7. Include a minimum of one (1) detail elevation view(s) of all rack(s) and/or enclosure(s) housing the Emergency Responder Radio Antenna/Repeater System equipment. Identify each piece of equipment by brand, model number and equipment type (e.g. Acme BA123 RF amplifier).
 8. Specify antenna grounding and surge protection in accordance with NEC Article 810.
 9. Specify the backup power source (Life Safety), and include calculations to ensure the backup power requirements as specified in this standard are met.
- C. Equipment Specification Sheets
1. Provide copies of manufacturer specification sheets of all system components, including:
 - a. Amplifiers
 - b. Antennas
 - c. Coaxial cable, couplers, splitters, combiners, or other passive components
 2. Operation and maintenance data
 3. Pass band curves in for the uplink and downlink portions of the NPSPAC band for any amplifiers, if not included in #1. Amplifiers may NOT amplify portions of other licensed services, including Nextel and Specialized Mobile Radio Licensee band, or Cellular A or B bands.
 4. Backup battery and charging system.
- D. Submit wiring diagrams from manufacturer differentiating clearly between factory and field-installed wiring. Include diagrams for each component of the system with all terminals and interconnections identified. Make all diagrams specific to this Project.
- E. Submit product certificates signed by the manufacturer of radio system components certifying that their products comply with specified requirements.
- F. Submit agenda for training class and copies of all handouts for the class.
- G. Maintenance data for radio system shall be included in the operation and maintenance manual. Include data for each type of product, including all features and operating sequences, both automatic and manual. Provide the names, addresses, and telephone numbers of service organizations that carry stock of repair parts for the system to be furnished.
- H. Record of field tests of the radio system shall be included in the operation and maintenance manuals.
- I. Design Approval: Plans shall be submitted and approved prior to installation. The following information shall be provided to the local Fire Department unit representative by the system designer/Contractor:
1. A minimum of three (3) copies of detailed drawings showing the location of the amplification equipment and associated antenna systems which includes a view showing building access to the equipment; and
 2. A minimum of three (3) copies of schematic drawings of the electrical system, backup power, antenna system and any other associated equipment relative to the amplification equipment including panel locations and labeling.
 3. A minimum of one (1) copy of the Manufacturer's data sheets on all equipment to be installed.

5. QUALITY ASSURANCE

- A. Installer Qualifications: Engage an experienced factory-authorized installer to perform work of this Section.
- B. Single-Source Responsibility: Obtain radio system components from a single source who assumes responsibility for compatibility of system components.
- C. All equipment shall be UL listed and labeled, and in accordance with applicable NEMA and ANSI Standards. Where copper cabling is routed to an area, either in another building, or with a separate electrical service, the Technology Contractor shall provide primary protective equipment.
- D. All racks and enclosures shall be either welded or assembled with paint piercing ground washers, grounding strip and bonding jumper as indicated on the Drawings.

6. MANUFACTURERS

- A. Subject to compliance with requirements, available Integrators offering products that may be incorporated into the Work include, but are not limited to, the following:
 - 1. CommScope/Andrew
 - 2. Corning
 - 3. Times Microwave
 - 4. Tescro
 - 5. CCI (Communication Components Inc.)
 - 6. Solid Technologies

7. PRODUCTS GENERAL PERFORMANCE REQUIREMENTS

- A. Compatibility: The equipment, including but not limited to repeaters, transmitters, receivers, signal boosters, cabling, fiber distributed antenna system, etc., shall not interfere with any other communication systems.
- B. Power Supplies: At least two (2) independent and reliable power supplies shall be provided, one primary and one secondary. The primary power source shall be supplied from a dedicated 20 ampere branch circuit and comply with 4.4.1.4 of NFPA 72. The secondary power source shall be a dedicated battery, capable of operating the in-building radio system for at least 12 hours of 100% system operation. The battery system shall automatically charge in the presence of external power input. The battery system shall be contained in one NEMA 4 or 4X type enclosures. Monitoring the integrity of power supplies shall be in accordance with 4.4.7.3 of NFPA 72.
- C. Survivability
 - 1. Physical Protection: All wiring and fiber optics shall be installed in conduit.
 - 2. Fire Performance: All main risers or trunks of the antenna system shall be installed with resistance to attack from a fire using one of the following methods:
 - a. A 2-hour fire rated cable or cable system.
 - b. Routing the cable through a 2-hour fire rated enclosure(s) or shaft(s).
 - c. A system configured in a looped design, routed through 1-hour fire rated enclosure(s) or shaft(s). The circuit shall be capable of transmitting and receiving a signal during a single open or non-simultaneous single ground fault on a circuit conductor.
 - d. Performance alternative approved by the Authority Having Jurisdiction.
 - 3. Cabinet: The signal booster and all associated RF filters shall be housed in a single, NEMA 4 certified, painted steel weather tight box. The cabinet shall be large enough to dissipate internal heat without venting the inside of the cabinet to the outside atmosphere. Operating temperatures: -22 degrees F to +120 degrees F (-30 degrees C to +50 degrees C) minimum temperature range, including microprocessors. Equipment installed on the roof of structures shall be rated for the expected extreme temperatures associated with rooftop installations.
 - 4. Passive Equipment: Passband shall be 700-900 MHz, IP rating of 2 GHz.
 - 5. Cable: Passband shall be 700-900 MHz. Cable shall be rated for fire plenum and riser rating.

8. SYSTEM COMPONENTS

- A. Signal Strength
 - 1. Downlink: A minimum signal strength of -95 dBm shall be provided throughout the coverage area.
 - 2. Uplink: Minimum signal strength of -95 dBm received at the local Fire Department Radio System from the coverage area.

3. A donor antenna must maintain isolation from the distributed antenna system. The donor antenna signal level shall be a minimum of 15 dB above the distributed antenna system under all operating conditions.
- B. Permissible Systems
 1. Buildings and structures shall be equipped with an FCC Certificated Class B Bi-Directional UHF Amplifier(s) as needed.
 2. The distributed antenna system may utilize a radiating cable, fixed antennas or a combination of both.
- C. Supported Frequencies: The radio system shall support frequencies in the 700 and 800 MHz public safety bands as utilized by the local Fire Department.
- D. Reject Filters: Notch filter sections shall be incorporated to minimize adjacent channel cellular and SMR (Nextel) degradation of the signal booster performance. The minimum downlink band adjacent band rejection shall be 35 dB or greater at 865 MHz and 870 MHz.
- E. Band Migration Capability: The signal booster shall include re-tunable or replaceable filters to accommodate rapid and economic passband changes in the event of mandatory FCC changes within the NPSPAC band. The use of non-adjustable and non-replaceable RF input and output filters is prohibited.
- F. Output Level Control: An automatic output leveling circuit shall be included for both passbands with a minimum dynamic range of 60 dB, less any gain reduction setting, to maintain FCC out of band and spurious emission compliance.
- G. Degraded Performance in Emergencies: The system shall be designed to allow degraded performance in adverse conditions, such as abnormally high temperatures resulting from nearby fires, extreme voltage fluctuations or other abnormal conditions that may occur during an emergency. Circuits that intentionally disable the signal booster in such situations (i.e. under/over voltage, over/under current, over/under temperature, etc.) will not be implemented as the standard mode for public safety applications.
- H. Mode of Operation: The system shall be normally powered on and shall continuously provide passing of frequencies within the Public Safety and First Responder bands.
- I. All in-building radio systems shall be compatible with both analog and digital communications simultaneously at the time of installation.

9. SYSTEM MONITORING

- A. The distributed antenna system shall include a connection to the fire alarm system to monitor the integrity of the circuit of the signal booster(s) and power supplies and annunciate this malfunction on the fire alarm system shall comply with 4.4.7.1 of NFPA 72.
- B. A sign shall be located at the fire alarm panel with the name and telephone number of the local Fire Department indicating that they shall be notified of any failures that extend past the 2 hour time limit.

10. INSTALLATION

- A. Distribution System Signal Wires and Cables
 1. Wires and cables shall enter each equipment enclosure, console, cabinet or rack in such a manner that all doors or access panels can be opened and closed without removal or disruption of the cables.
 2. Routing and Interconnection
 - a. Wires or cables routed between consoles, cabinets, racks, and other equipment shall be installed in an approved conduit or cable tray that is secured to building structure.
 - b. Completely test all of the cables after installation and replace any that are found to be defective.
 3. Install cables without damaging conductors, shield, or jacket.
 4. Do not bend cables, while handling or installing, to radii smaller than as recommended by manufacturer.
 5. Pull cables without exceeding cable manufacturer's recommended pulling tensions.
- B. Product Delivery, Storage, and Handling
 1. Delivery: Deliver materials to the job site in OEM's original unopened containers, clearly labeled with the OEM's name and equipment model and serial identification numbers.
 2. Store and protect equipment in a conditioned space until installation.
- C. System Installation

1. Coaxial antenna cabling shall not be installed in the same conduit, raceway, or cable trays used for other systems.
2. All equipment shall be connected according to the OEM's specifications to insure correct installation and system performance.
3. Coordinate all roof penetrations with Owner and roofing contractor.

11. LICENSING

- A. All fees associated with the licensing shall be paid by the Owner.
- B. All testing must be done on frequencies authorized by the FCC.

12. GROUNDING

- A. Ground cable shields and equipment per Manufacturer's requirements.
- B. Antenna mast shall be grounded per NFPA 70 NEC requirements, and antenna manufacturer's requirements. Provide grounding blocks and surge protection for outside coaxial cabling. Bond the antenna mast to the lightning protection system.

13. APPROVAL TESTING

- A. The local Fire Department shall review plans and specifications. Upon acceptance, plans shall be stamped to indicate approval. Stamped plans are required to be present at the acceptance test. Any field changes that occur during construction shall be incorporated into new As-Built plans, including any manufacturer's data sheets for any equipment changes not submitted in the original submittal. As-Built plans, if required due to system changes, shall be submitted to the local Fire Department for approval.
- B. Tests shall be made using frequencies close to the frequencies used by the Fire Department and appropriate emergency services. If testing is done on the actual frequencies, then this testing must be coordinated with the local Fire Department unit. All testing must be done on frequencies authorized by the FCC. A valid FCC license shall be required if testing is done on frequencies different from the police, fire or emergency medical frequencies.
- C. Testing Procedures
 1. Minimum Signal Strength: For testing system signal strength and quality, the testing shall be based on the delivered audio quality (DAQ) system. A DAQ level below 3.0 shall be considered a failed test for a given grid cell.
 2. Measurements shall be made with the antenna held in a vertical position at 3 to 4 feet above the floor to simulate a typical portable radio worn on the belt or turnout coat pocket.
- D. Final Acceptance Testing
 1. All acceptance testing shall be done in the presence of a local Fire Department representative or by the local Fire Department unit at no expense to the City or Town.
 2. Small scale drawings (11 inch x 17 inch maximum) of the structure shall be provided by the Contractor to the Owner. The plans shall show each floor divided into the grids as described above, and the results of the pre-testing. Each grid shall be labeled to indicate the DAQ result from the final acceptance testing.
 3. The Contractor shall provide the latest approved plans for the system, including any manufacture's data sheets for any equipment changes not submitted in the original submittal to the Owner.
 4. Include testing results of the repeater (output wattage, gain level, etc) and connection to the fire alarm.

14. MAINTENANCE AND ANNUAL TESTING

- A. Annual tests will be conducted by the local Fire Department unit or authorized company.
 1. The re-testing will be done at no expense to the City or the appropriate emergency services departments as required in the original testing procedures.
- B. Maintenance Contract
 1. Maintenance contract with a Radio Service Provider in place with name of authorized company, who will provide a 24 hour by 7-day emergency response within two (2) hours after notification. The system shall be maintained in accordance with FCC requirements. The contract shall be for 5 years.
 2. All tests shall be conducted, documented, and signed by a person in possession of a current FCC General Radio telephone Operator License, or a technician certification issued by the Association of Public-Safety Communications Officials International (APCO) or equivalent as determined by the local Fire Department.

3. Maintain a list of contact personnel with phone numbers at the radio repeater system cabinet. The contact personnel shall have knowledge of the building and the repeater system and be available to respond to the building in the case of an emergency.
4. Radio Service Provider maintenance contract shall include but not limited to:
 - a. Annual Test
 - 1) All active components of the distributed antenna system, including but not limited to amplifier, power supplies, and back-up batteries, shall be tested a minimum of once every 12 months.
 - 2) Amplifiers shall be tested to ensure that the gain is the same as it was upon initial installation and acceptance. The original gain shall be noted and any change in gain shall be documented.
 - 3) Back-up batteries and power supplies shall be tested under load for a period of 1 hour to verify that they will operate during an actual power outage.
 - 4) Active components shall be checked to determine that they are operating within the manufacturer's specifications for their intended purpose.
 - 5) Documentation of the test shall be maintained on site and a copy forwarded to the local Fire Department Radio Supervisor upon completion of the test.
 5. Fire Department Radio personnel, after providing reasonable notice to the Owner or their representative, shall have the right to enter onto the property to conduct field testing to be certain that the required level of radio coverage is present.

2.26 SHORT CIRCUIT/COORDINATION STUDY AND ARC FLASH RISK ASSESSMENT

A. GENERAL

1. The electrical contractor shall retain the services of an independent third-party firm, or the equipment manufacturer's technical services group, to perform a short circuit/coordination study and arc flash risk assessment as described herein
2. Preliminary studies shall be submitted to the A/E prior to receiving final approval of the distribution equipment shop drawings and/or prior to release of equipment for manufacture to ensure the characteristics and ratings of the proposed overcurrent devices will be satisfactory. The final submittal shall capture any changes in circuit lengths, wire sizes, additional loads, etc. that may occur during the construction project
3. The studies shall include all portions of the electrical distribution system from the normal power source or sources, and emergency/standby sources, down to and including the smallest circuit breaker in the distribution system (for short circuit calculations). Normal system connections and those which result in maximum fault conditions shall be adequately covered in the study
4. The firm should be currently involved in medium- and low-voltage power system evaluation. The study shall be performed, stamped and signed by a registered professional engineer in the State of the project is located in. Credentials of the individual(s) performing the study and background of the firm shall be submitted to the A/E for approval prior to start of the work. A minimum of five (5) years experience in power system analysis is required for the individual in charge of the project
5. The firm performing the study should demonstrate capability and experience to provide assistance during start up as required
6. The study and assessment shall be performed on SKM Dapper, Captor and PowerTool software or EasyPower product suite software.

B. REFERENCE STANDARDS

1. Standards listed in the IEEE "Buff Book", latest edition
2. National Fire Protection Association (NFPA) 70E, latest addition
3. IEEE 1584 – Guide for Performing Arc Flash Calculations

C. DATA COLLECTION FOR THE STUDY

1. The contractor shall provide the required data for preparation of the studies. The engineer performing the system studies shall furnish the contractor with a listing of the required data immediately after award of the contract.
2. The contractor shall expedite collection of the data to assure completion of the studies as required for final approval of the distribution equipment shop drawings and/or prior to release of the equipment for manufacture.

D. SUBMITTALS

E. THIRD PARTY QUALIFICATIONS

1. Submit qualifications of individual(s) who will perform the work to the A/E for approval prior to commencement of the studies.
- F. PRELIMINARY REPORT
1. Submit a draft of the studies to the A/E for review prior to delivery of the final study to the Owner. Make all additions or changes as required by the reviewer.
- G. FINAL STUDY REPORT
1. Provide studies in conjunction with equipment submittals to verify equipment ratings required.
 2. The results of the power system studies shall be summarized in a final report and provided in the following formats. Provide (2) bound hard copies of the final report. Provide (2) electronic copies (on CD) of the final report and one-line diagrams in PDF format. Provide (2) electronic copies (on CD) of the final report in MS Word format and the one-line diagrams in CAD format.
 3. Also provide (2) electronic copies (on CD) of all files generated by the SKM or EasyPower software for all scenarios evaluated in the studies. The files shall permit the studies to be opened, reviewed or updated by any user of the analysis software used for the studies.
 4. The report shall typically include the following sections:
 - I. Overview
 - II. Short Circuit Study
 - SC-1 Purpose
 - SC-2 Explanation of Data
 - SC-3 Assumptions
 - SC-4 Analysis of Results
 - SC-5 Recommendations
 - SC-6 Fault Analysis Input Report from Software Program
 - SC-7 Fault Contribution Report
 - III. Protective Device Coordination Study
 - PDC-1 Purpose
 - PDC-2 Explanation of Data
 - PDC-3 Assumptions
 - PDC-4 Analysis of Results
 - PDC-5 Recommendations (Including NEC 700-27 Requirement)
 - PDC-6 Results from Software Program
 - PDC-7 Example Drawings
 - IV. Arc Flash Study
 - ARC-1 Purpose
 - ARC-2 Explanation of Data
 - ARC-3 Assumptions
 - ARC-4 Analysis of Results
 - ARC-5 Recommendations
 - ARC-6 Arc Flash Evaluation Report from Software Program
 - V. Prioritized Recommendations and Conclusions
 - VI. Appendices
 - APP-1 One-line Diagrams from Software Program
 - APP-2 AutoCAD One-line Diagrams
 - APP-3 Protective Device Summaries from Software Program
 - APP-4 Reference Data
 - APP-5 Sample Work Permit Form
 - APP-6 Copy of Warning Labels, including study date
 5. The above sections shall include the following items in detail:
 - a. Obtain available fault current from the local utility company.
 - b. Short circuit studies shall evaluate the available fault current at each bus (each change of impedance), including all three-phase motors.
 - c. Coordination study recommendations for relay settings, breaker settings, and motor protection settings.
 - d. Recommendations for improving the coordination and/or load distribution, as well as ground fault requirements.

- e. Worst case Arc Flash values (highest incident energy) for project specific scenarios (low short circuit and high short circuit for each possible power supply source).
- f. Arc flash values for two maintenance cases, which define the arc flash values available at the equipment that would be available if the instantaneous trip of the upstream circuit breaker is set at a minimum value. This is recommended if someone must work on live equipment.
- g. IEEE standard one-line diagram with equipment evaluation and circuit breaker settings that clearly define the system data and are easy to interpret. The diagrams should include the bus names and references used in the studies.
- h. Recommendations to reduce the arc flash incident energy in all areas that are subject to 8 calories per square centimeter or greater of available incident energy.
- i. Condition of Maintenance information for any existing equipment included in the study.
- j. Prioritized report summarizing all recommendations from this study. This shall include observed NEC code violations and their corrective action.
- k. The contractor shall provide a one-line diagram that meets IEEE/ANSI standard 141, mounted on 24" x 36" (minimum) Styrofoam backboard. This one-line diagram shall be mounted in each electrical room.

H. EXECUTION

1. SHORT CIRCUIT AND COORDINATION STUDY

- a. The short circuit, coordination, and arc flash hazard studies shall be performed using SKM Dapper, Captor and PowerTool for Windows software or EasyPower product suite Windows based software packages. In the short circuit study, provide calculation methods and assumptions, the base per unit quantities selected, one-line diagrams, source impedance data including power company system characteristics, typical calculations, and recommendations. Calculate short circuit interrupting and momentary (when applicable) duties for an assumed 3-phase bolted fault at each supply switchgear lineup, unit substation primary and secondary terminals, low voltage switchgear lineup, switchboard, motor control center, distribution panelboard, pertinent branch circuit panelboard, and other significant locations throughout the system. Provide a ground fault current study for the same system areas, including the associated zero sequence impedance data. Include in tabulations fault impedance, X to R ratios, asymmetry factors, motor contribution, short circuit KVA, and symmetrical and asymmetrical fault currents.
- b. In the protective device coordination study, provide time-current curves graphically indicating the coordination proposed for the system, centered on conventional, full-size, log-log forms. Include with each curve sheet a complete title and one-line diagram with legend identifying the specific portion of the system covered by that particular curve sheet. Include a detailed description of each protective device identifying its type, function, manufacturer, and time-current characteristics. Tabulate recommended device tap, time dial, pickup, instantaneous, and time delay settings.
- c. Include on the curve sheets power company relay and fuse characteristics, system medium-voltage equipment relay and fuse characteristics, low-voltage equipment circuit breaker trip device characteristics, pertinent transformer characteristics, pertinent transformer characteristics, pertinent motor and generator characteristics, and characteristics of other system load protective devices. Include at least all devices down to largest branch circuit and largest feeder circuit breaker in each motor control center, and main breaker in branch panelboards.
- d. Include all adjustable settings for ground fault protective devices. Include manufacturing tolerance and damage bands in plotted fuse characteristics. Show transformer full load and 150, 400, or 600 percent currents, transformer magnetizing inrush, ANSI transformer withstand parameters, and significant symmetrical and asymmetrical fault currents. Terminate device characteristic curves at a point reflecting the maximum symmetrical or asymmetrical fault current to which the device is exposed.
- e. Select each primary protective device required for a delta-wye connected transformer so that its characteristic or operating band is within the transformer characteristics, including a point equal to 58 percent of the ANSI withstand point to provide secondary line-to-ground fault protection. Where the primary device characteristic is not within the transformer characteristics, show a transformer damage curve. Separate transformer primary protective device

- characteristic curves from associated secondary device characteristics by a 16 percent current margin to provide proper coordination and protection in the event of secondary line-to-line faults. Separate medium-voltage relay characteristic curves from curves for other devices by at least a 0.4-second time margin.
- f. Include complete fault calculations as specified herein for each proposed and ultimate source combination. Note that source combinations may include present and future supply circuits, large motors, or generators as noted on drawing one-lines.
 - g. Utilize equipment load data for the study obtained by the Contractor from contract documents, including contract addendums issued prior to bid openings.
 - h. Include fault contribution of all motors in the study. Notify the Engineer in writing of circuit protective devices not properly rated for fault conditions.
 - i. Provide settings for the chiller motor starters or obtain from the mechanical contractor, include in the study package, and comment.
 - j. When an emergency generator is provided, include phase and ground coordination of the generator protective devices, to meet NEC 700.27 requirements. Show the generator decrement curve and damage curve along with the operating characteristic of the protective devices. Obtain the information from the generator manufacturer and include the generator actual impedance value, time constants and current boost data in the study. Do not use typical values for the generator.
 - k. Evaluate proper operation of the ground relays in 4-wire distributions with more than one main service circuit breaker, or when generators are provided, and discuss the neutral grounds and ground fault current flows during a neutral to ground fault.
 - l. For motor control circuits, show the MCC full-load current plus symmetrical and asymmetrical of the largest motor starting current to ensure protective devices will not trip major or group operation.
- I. FIELD SETTINGS
- 1. The Contractor shall perform field adjustments of the protective devices as required to place the equipment in final operating condition. The settings shall be in accordance with the approved short circuit study, protective device coordination study and arc flash risk assessment.
 - 2. Necessary field settings and adjustments of devices and minor modifications to equipment to accomplish conformance with the approved short circuit and protective device coordination study shall be carried out by the Contractor at no additional cost to the owner.
- J. ARC FLASH RISK ASSESSMENT
- 1. As part of the short circuit and coordination study, arc flash risk assessment shall be included. The study shall include the following:
 - a. Determine and document all possible utility and generator/emergency sources that are capable of being connected to each piece of electrical gear. Calculations shall be based on highest possible source connection.
 - b. Calculations to conform to National Fire Protection Association (NFPA) 70E recognized means of calculation standards. All incident energy units shall be calculated in calories per square centimeter.
 - c. Provide recommended boundary zones and personal protective equipment (PPE) based on the calculated incident energy and requirements of NFPA 70E for each piece of electrical gear.
 - d. Electrical Contractor shall provide warning labels as required by OSHA based upon the results of the arc flash risk assessment. At a minimum, the labeling shall contain the following information: nominal system voltage, arc flash boundary, limited approach boundary, restricted approach boundary, available incident energy and the corresponding working distance or the arc flash PPE category, minimum arc rating of clothing, and study date. Label shall also include the name or logo and the phone number of the company performing the study.
 - e. Arc flash warning labels shall be affixed to all electrical equipment that is likely to require examination, adjustment, servicing or maintenance while energized. This includes, but is not limited to, medium-voltage switchgear, transformers, switchboards, panel boards, three-phase disconnect switches, transfer switches, motor control centers, motor controllers, and three-phase motor disconnect switches.

PART 3 – EXECUTION

3.1 BASIC REQUIREMENTS

- A. Adhere to best industry practice and the following:
1. All work shall be concealed.
 2. Route circuitry runs embedded in concrete to coordinate with structural requirements.
 3. Equip each raceway intended for the future installation of wire or cable with a nylon pulling cord 3/16" in diameter and clearly identify both ends of the raceway.
 4. Provide all outlet boxes, junction boxes, and pull boxes for proper wire pulling and device installation. Include those omitted from the drawings due to symbolic methods of notation.
 5. Utilize lugs of the limited type to make connections at both ends of cables installed on the line side of main service overcurrent and switching devices. Provide cable limiters for each end of each service entrance cable.
 6. Beyond the termination of raceways, fireproof the following:
 - a. All wires and cables within pad-mounted transformer enclosure.
 - b. All service feeder cables ahead of main service overcurrent protection devices, and elsewhere where not in raceways.
 7. Fireproofing of wires and cables shall be by means of a half-lapped layer of arcproof or by means of sleeving of a type specifically manufactured for the purpose. Ends of tape or sleeving shall be severed with twine. Fireproofing shall be extended up into raceways. After conductors have been finally shaped into their permanent configuration, fireproofing tape or sleeving shall be coated with silicate of soda (water glass). Fireproofing shall be applied in an overall manner to raceway groupings of conductors.
 8. Provide all sleeves through fireproof and waterproof slabs, walls, etc., required for electric work.
 9. Provide waterproof sealing for the sleeves through waterproof slabs, walls, etc.
 10. Provide fireproof sealing for the sleeves through fireproof walls, slabs, etc.
 11. Provide fireproof sealing for the openings in fireproof walls, slabs, etc., resulting from removal of existing electrical sleeves, conduits, poke-thru's etc.
 12. No splicing of wires will be permitted in the Fire Alarm System.
 13. Bundle wiring passing through pull boxes and panelboards in a neat and orderly manner with plastic cable ties. Cable ties shall be by Ty-Raps as manufactured by Thomas & Betts, Holub Industries Inc., Quick Wrap, Bundy Unirap, or equal.
 14. Turn branch circuits and auxiliary system wiring out of wiring gutters at 90 degrees to circuit breakers and terminal lugs.

3.2 TESTING REQUIREMENTS & INSTRUCTIONS

- A. Where any repairs, modifications, adjustments, tests or checks are to be made, the Contractor shall contact the Engineer to determine if the work should be performed by or with the Manufacturer's Representative.
- B. Tests are to:
1. Provide initial equipment/system acceptance.
 2. Provide recorded data for future routine maintenance and troubleshooting.
 3. Provide assurance that each system component is installed satisfactorily and can be expected to perform, and continue to perform its specified function with reasonable reliability throughout the life of the facility.
- C. At any stage of construction and when observed, any electrical equipment or system determined to be damaged, or faulty, is to be reported to the Engineer. Corrective action by the Contractor requires prior Engineer approval, retesting, and inspection.
- D. When the electrical tests and inspections specified or required within Division 16 are completed and results reported, reviewed, and approved by the Engineer, the Contractor may consider that portion of the electrical equipment system or installation electrically complete. The Contractor will then affix appropriate, approved, and dated completion or calibration labels to the tested equipment and notify the Engineer of electrical completion. If the Engineer finds completed work unacceptable, he will notify

the Contractor in writing of the unfinished or deficient work, with the reason for his rejection, to be corrected by the Contractor. The Contractor will notify the Engineer in writing when exceptions have been corrected. The Contractor will prepare a "Notification of Substantial Electrical Completion" for approval by the Engineer following Engineer's acceptance of electrical completion. If later in-service operation or further testing identified problems attributable to the Contractor, these will be corrected by the Contractor, at no additional cost to the Authority.

E. Grounding Systems:

1. Test main building loops and major equipment grounds to remote earth, directly referenced to an extremely low resistance (approximately 1 ohm) reference ground benchmark. Perform a visual inspection of the systems, raceway and equipment grounds to determine the adequacy and integrity of the grounding. Ground testing results shall be recorded, witnessed, and submitted to the Engineer.
2. Perform ground tests using a low resistance, null-balance type ground testing ohmmeter, with test lead resistance compensated for. Use the type of test instrument which compensates for potential and current rod resistances.
3. Test each ground rod and measure ground resistance. If resistance is not 10 ohms or less, drive additional rods to obtain a resistance of 10 ohms or less. Submit tabulation of results to Engineer. Include identification of electrode, date of reading and ground resistance value in the test reports.
4. Test each building and major equipment grounding system for continuity of connections and for resistance. Ground resistance of conduits, equipment cases, and supporting frames, shall not exceed 5 ohms to ground. Submit all readings to the Engineer.
5. Where ground test results identify the need for additional grounding conductors or rods that are not indicated or specified, design changes will be initiated to obtain the acceptable values. The Contractor is responsible for the proper installation of the grounding indicated and specified.
6. Operating Instructions: Furnish operating instructions to Owner's designated representative with respect to operations, functions and maintenance procedures for equipment and systems installed. Cost of such instruction up to a full five (5) days of Electrical Subcontractor's time shall be included in contract. Cost of providing a Manufacturer's Representative at site for instructional purposes shall also be included.

3.3 BRANCH CIRCUITRY

- A. For all lighting and appliance branch circuitry, raceway sizes shall conform to industry standard maximum permissible occupancy requirements except where these are exceeded by other requirements specified elsewhere.
- B. Circuits shall be balanced on phases at their supply as evenly as possible.
- C. Feeder connections shall be in the phase rotation which establishes proper operation for all equipment supplied.
- D. Reduced size conductors indicated for any feeders shall be taken as their grounding conductors.
- E. Feeders consisting of multiple cables and raceways shall be arranged such that each raceway of the feeder contains one (1) cable for each leg and one (1) neutral cable, if any.
- F. For circuitry indicated as being protected at 20 Amps or less, abide by the following:
 1. All 20 amp, 120/208 volt, 3-phase, 4-wire combined branch circuit homeruns shall be provided with a #8 AWG neutral conductor.
 2. Minimum conductor size shall be No. 12 AWG cooper.
 3. Conductors operating at 120 volts extending in excess of 100 ft. or at 277 volts extending in excess of 200 ft., or the last outlet or fixture tap shall be No. 10 AWG cooper throughout.
 4. Lighting fixtures and receptacles shall not be connected to the same circuit.
- G. Type MC Cable Installation:
 1. Where cable is permitted under the products section, the installation of same shall be done in accordance with code and the following:
 - a. Cable shall be supported in accordance with code. Tie wire is not an acceptable means of support. Cable supports such as Caddy WMX-6, MX-3, and clamps such as Caddy 449 shall be used. Where cables are supported by the structure and only need securing in place, then

- ty-raps will be acceptable. Ty-raps are not acceptable as a means of support. All fittings, hangers, and clamps for support and termination of cables shall be of type specifically designed for use with cable, i.e., romex connectors not acceptable.
- b. Armor of cable shall be removed with rotary cutter device equal to roto-split by Seatek Co.; not with a hacksaw.
 - c. Use split "Insuliner" sleeves at terminations.

3.4 REQUIREMENTS GOVERNING ELECTRICAL WORK IN DAMP OR WET LOCATIONS

- A. Outlets and outlet size boxes shall be of galvanized cast ferrous metal only.
- B. The finish of threaded steel conduit shall be galvanized only.
- C. Wires for pulling into raceways for lighting and appliance branch circuitry shall be limited to "THWN".
- D. Wires for pulling into raceways for feeders shall be limited to "THWN".
- E. Plates for toggle switches and receptacles shall have gasketed snap shut covers suitable for wet locations while in use.
- F. Final connections of flexible conduit shall be neoprene sheathed.
- G. Apply one (1) layer of half looped plastic electric insulating tape over wire nuts used for joining the conductors of wires.
- H. Enclosures, junction boxes, pull boxes, cabinets, cabinet trims, wiring troughs and the like, shall be fabricated of galvanized sheet metal, shall conform to the following:
 - 1. They shall be constructed with continuously welded joints and seams.
 - 2. Their edges and weld spots shall be factory treated with cold galvanizing compound.
 - 3. Their connection to circuitry shall be by means of watertight hub connectors with sealing rings.
- I. Enclosures for individually mounted switching and overcurrent devices shall be NEMA Class IV weatherproof construction.
- J. The covers, doors and plates and trims used in conjunction with all enclosures, pull boxes, outlet boxes, junction boxes, cabinets and the like shall be equipped with gaskets.
- K. Panels shall be equipped with doors without exception.
- L. The following shall be interpreted as damp or wet locations within building confines:
 - 1. Spaces where any designations indicating weatherproof (WP) or vapor proof appear on the drawings.
 - 2. Below waterproofing in slabs applied directly on grade.
 - 3. Spaces defined as wet or damp locations by Article 100 of the National Electric Code.
 - 4. Parking garage.

3.5 REQUIREMENTS GOVERNING ELECTRIC WORK IN AIR HANDLING SPACES

- A. Within air handling ductwork or plenums (other than spaces within suspended ceilings used for air handling purposes), Area "B" and the media shall comply with requirements for return air plenums.
- B. Abide by the requirements specified for electric work in damp locations within building confines.
- C. Where circuitry passes through duct walls, include, in accordance with instructions issued in the field, airtight sealing provisions which allow for a relative movement between the circuitry and the duct walls.
- D. Exclude the installation of type NM or NMC cable.
- E. In spaces within suspended ceilings used for air handling purposes, abide by the requirements specified for normal electric work conditions except:
- F. Lighting fixtures recessed into the ceilings shall be certified as being suitable for this purpose.

3.6 UNDERGROUND CONDUIT DUCT BANKS

- A. The electrical work required in conjunction with underground conduit banks shall include providing all conduits.
- B. Conduits for underground banks shall be:
 - 1. Trade diameter size as indicated but in no case less than one inch.
 - 2. Polyvinyl chloride Schedule 40 (approved for encased burial) duct, rigid steel conduit for vertical elbows and straight sections used to penetrate equipment pads, building foundation walls and concrete slabs.

- C. All conduits indicated as being incorporated into conduit banks unless specifically noted as rigid steel conduits shall be encased in a concrete envelope which accommodates the indicated configuration of conduits and which encompasses dimensions as follows:
 - 1. Outside surfaces of conduits to outside surface of envelope where reinforcement of encasement is required – 6” minimum.
 - 2. Outside surfaces of conduits to outside surface of envelope where no reinforcement of encasement is required – 3” minimum.
 - 3. Spacing between centerlines of conduits assigned to different categories of use primary feeders, secondary feeders, communications and signaling – 10-1/2” minimum.
 - 4. Spacing between centerlines of conduits assigned to the same category of use – 7-1/2” minimum.
- D. Reinforcement of the concrete encasement for conduit banks where required shall consist of No. 4 longitudinal reinforcing bars located 3” from the outside surface of the envelope and spaced 6” on centers all around. No. 8 wire reinforcing hoops set 8” apart shall be used to tie the longitudinal bars together.
- E. Install conduit in such a manner as to provide a minimum cover of 30 inches after final grading except the cover may be reduced to a minimum of 18 inches to:
 - 1. Tie into existing work.
 - 2. Pass over other underground utilities.
 - 3. Pass over underground obstructions.
 - 4. Assist in the avoidance of low points.
- F. Increase the minimum cover where required by field conditions.
- G. Lay conduit to avoid low points during run. Pitch at a minimum of 3 inches per 100 feet away from building.
- H. Provide reinforcement for the concrete encasement of a conduit bank where:
 - 1. It passes under or over underground utilities.
 - 2. It passes under or over underground obstructions.
 - 3. Its cover is reduced to less than 30 inches.
 - 4. It runs through foundation walls and other building construction.
- I. Concrete encasement reinforcing shall extend in each case 5 feet beyond the points at which the determining conditions terminate.
- J. Bends in conduit shall have minimum radii as follows:
 - 1. For primary feeder 15'-0" except where specifically indicated otherwise or where turning up at termination point.
 - 2. For primary feeder turning up at termination point – 4'-0".
- K. Install conduit so that adjacent joints are staggered at least 6 inches from one another.
- L. Offsets to accommodate field conditions shall be accomplished with two (2) bends of not more than ten (10) degrees each.
- M. Plug both ends of all conduit stubs.
- N. Seal the end of each conduit run terminating inside a building utilizing a water and gas-tight sealant manufactured specifically for the purpose.
- O. After conduit has been installed with concrete encasement completed, clear each conduit of all obstructions and foreign matter by pulling a flexible mandrel (12" minimum length and a diameter 1/4" less than that of the conduit) and brush through it. In the event that obstructions are encountered in any conduit which will not permit the mandrel to pass, remove and replace the blocked section. Include in the electric work all excavation, backfilling, repair of concrete encasement and restoration of surface at grade involved in the conduit replacement.
- P. Provide a nylon cord for the pulling of cable in each conduit in which no cable is to be installed as part of the electric work.
- Q. The Electrical Sub-Contractor shall provide all insulated racks as required for proper support of all cables and wires.
- R. Provide a continuous nylon warning tape above each full length of duct bank 12 inches below grade.

3.7 LIMITING NOISE PRODUCED BY ELECTRICAL INSTALLATION

- A. Perform the following work, in accordance with field instructions issued by the Architect to assure that minimal noise is produced by electrical installations due to equipment furnished as part of the electrical work.
- B. Check and tighten the fastenings of sheet metal plates, covers, doors and trims used in the enclosures of electrical equipment.
- C. Remove and replace any individual device containing one or more magnetic flux path metallic cores (e.g., discharge lamp ballast, transformer, reactor, dimmer, and solenoid) which is found to have a noise output exceeding that of other identical devices installed at the project.

3.8 SUPPORTS AND FASTENINGS

- A. Support work in accordance with best industry standards, and Local Electric Code.
- B. Include supporting frames or racks for equipment, intended for vertical surface mounting, which is required in a free standing position.
- C. Supporting frames or racks shall be of standard angle, standard channel or specialty support system steel members. They shall be rigidly bolted or welded together and adequately braces to form a substantial structure. Racks shall be of ample size to assure a workmanlike arrangement of all equipment mounted on them.
- D. No work intended for exposed installation shall be mounted directly on any building surface. In such locations, flat bar members or spaces shall be used to create a minimum of ¼" air space between the building surfaces and the work. Provide ¾" thick exterior grade plywood painted with two (2) coats of fire-retardant gray paint for mounting of panelboards.
- E. Nothing (including outlet, pull and junction boxes and fittings) shall depend on electric conduits, raceways or cables for support.
- F. Nothing shall rest on, or depend for support on, suspended ceiling media.
- G. Support less than 2" trade size, vertically run, conduits at intervals no greater than 8'. Support such conduits, 2-1/2" trade size or larger, at intervals no greater than they story height, or 15', whichever is smaller.
- H. Where they are not embedded in concrete, support less than 1" trade size, horizontally run, conduits at intervals no greater than 7'. Support such conduits, 1" trade size or larger, at intervals no greater than 10'.
- I. Support all lighting fixtures directly from structural slab, deck or framing member.
- J. Where fixtures and ceilings are such as to require fixture support from ceiling openings frames, include in the electric work the members necessary to tie back the ceiling opening frames to ceiling suspension members or slabs so as to provide actual support for the fixtures noted above.
- K. As a minimum procedure, in suspended ceilings support smalls runs of circuitry (e.g., conduit not in excess of 1" trade size) from ceiling suspension members as defined above. Support larger runs of circuitry directly from structural slabs, decks or framing members.
- L. Fasten electric work to building structure in accordance with the best industry practice.
- M. Floor mounted equipment shall not be held in place solely by its own dead weight. Include floor anchor fastenings in all cases.
- N. For items which are shown as being ceiling mounted at locations where fastenings to the building construction element above is not possible, provide suitably auxiliary channel or angle iron bridging tying to building structural elements.
- O. As a minimum procedure, where weight applied to the attachment points is 100 lbs. or less, fasten to concrete and solid masonry with bolts and expansion shields.
- P. As a minimum procedure, where weight applied to building attachment points exceed 100 lbs., but is 300 lbs. or less, conform to the following:
 - 1. At field poured concrete slabs, utilize inserts with 20' minimum length slip-through steel rods, set transverse to reinforcing steel.

3.9 PULLING WIRES INTO CONDUITS AND RACEWAYS

- A. Delay pulling wires or cables in until the project has progressed to a point when general construction procedures are not liable to injure wires and cables, and when moisture is excluded from raceways.

- B. Utilize nylon snakes or metallic fish tapes with ball type heads to set up for pulling. In raceways 2" trade size and larger, utilize a pulling assembly ahead of wires consisting of a suitable brush followed by a 3-1/2" diameter ball mandrel.
- C. Leave sufficient slack on all runs of wire and cable to permit the secure connection of devices and equipment.
- D. Include circular wedge-type cable supports for wires and cables at the top of any vertical raceway longer than 20 feet. Also include additional supports spaced at intervals which are no greater than 10'. Supports shall be located in accessible pull boxes. Supports shall be of a non-deteriorating insulating material manufactured specifically for the purpose.
- E. Pulling lubricants shall be used. They shall be products manufactured specifically for the purpose.

3.10 REQUIREMENTS FOR THE INSTALLATION OF JUNCTION BOXES, OUTLET BOXES AND PULL BOXES

- A. Flush wall-mounted outlet boxes shall not be set back to back but shall be offset at least 12" horizontally regardless of any indication on the drawings.
- B. Locate all boxes so that their removable covers are accessible without necessitating the removal of parts of permanent building structure, including piping, ductwork, and other permanent mechanical elements.
- C. In conjunction with concealed circuitry, abide by one of the following instructions (as may be applicable to the conditions) in order to assure the aforementioned accessibility. (Not required for circuitry concealed by removable suspended ceiling tiles.)
- D. For a small (outlet size) box on circuitry concealed in a partition or wall, locate box or fitting so that its removable cover side, (or the face of any applied raised cover) penetrates through to within 1/8" of the exposed surface of the building materials concealing the circuitry and apply a blank or device plate to suit the functional requirements.
- E. For a large box on circuitry concealed in a partition, suspended ceiling, or wall, locate box totally hidden but with its removable cover directly behind an architectural access door or panel (included for the purpose, separate from the electric work) in the building construction which conceals the circuitry.
- F. Include all required junction and pull boxes regardless of indications on the drawings (which, due to symbolic methods of notation, may omit to show some of them).
- G. Unless noted below or otherwise specifically indicated, include a separate outlet box for each individual wiring device, lighting fixture and signal or communication system outlet component. Outlet boxes supplied attached to lighting fixtures shall not be used as replacements for the boxes specified herein.
- H. Utilize an outlet box no smaller than 5" square by 2-1/2" deep.
- I. Allow no fixture to be supplied from an outlet box in another room.
- J. Multiple local switches indicated at a single location shall be gang-mounted in a single outlet box.
- K. Install junction boxes, pull boxes and outlet boxes in conjunction with concealed circuitry.
- L. Close up all unused circuitry openings in outlet boxes. Unused openings in cast boxes shall be closed with approved cast metal threaded plugs. Unused openings in sheet metal boxes shall be closed with sheet metal knock-out plugs.
- M. Outlet boxes for switches shall be located at the strike side of doors. Indicate door swings are subject to field change. Outlet boxes shall be located on the basis of final door swing arrangements.
- N. Boxes and plaster covers for duplex receptacles shall be arranged for vertical mounting of the receptacle.
- O. Equip outlet boxes used for devices which are connected to wires of systems supplied by more than one set of voltage characteristics with barriers to separate the different systems.
- P. Barriers in junction and pull boxes of outlet size shall be of the same metal as the box.
- Q. Barriers in junction and pull boxes which are larger than outlet size shall be of the polyester resin fiberglass of adequate thickness for mechanical strength, but in no case less than 1/4" thick. Each barrier shall be mounted, without fastenings, between angle iron guides so that they may be readily removed.

3.11 LOCATING AND ROUTING OF CIRCUITRY

- A. In general, all circuitry shall be run concealed except that it shall be run exposed where the following conditions occur:
 - 1. Horizontally at the ceiling of permanently unfinished spaces which are not assigned to mechanical or electrical equipment.
 - 2. Horizontally and vertically in mechanical equipment spaces.
 - 3. Horizontally and vertically in electric equipment rooms.
- B. Concealed circuitry shall be so located that building construction materials can be applied over its thickest elements without being subject to spalling or cracking.
- C. All circuitry and raceways shall not be run within slabs. If field conditions requires raceways to be embedded in field-poured structural building construction concrete fill or slab shall conform to the following:
 - 1. Where turned up or down into a wall or partition they shall, before entering same, be routed parallel for a long enough distance to assure that no relocation of the wall or partition will be necessary to conceal the required bend.
 - 2. They shall be routed in such a manner as to coordinate with the structural requirements of the building.
 - 3. They shall be routed in accordance with field instructions issued by the Architect where such instructions differ from specifications set forth herein.
- D. Circuitry run exposed shall be routed parallel to building walls and column lines.
- E. Circuitry shall be routed so as to prevent electric conductors from being subject to high ambient temperature. Minimum clearances from heated lines or surfaces shall be maintained as follows:
 - 1. Crossing where uninsulated: 3".
 - 2. Crossing where insulated: 1"
 - 3. Running parallel where uninsulated: 36".
 - 4. Running parallel where insulated: 6".
- F. Circuitry shall not be run in elevator shafts, hoistways, and the like. Where outlets for trail cables, pit lights, run be level lights, and the like, are involved, only the "final connection" outlet boxes themselves shall be located within or open into, the confines of the shaft.

3.12 INSTALLING CIRCUITRY

- A. The outside surface of circuitry, which is to be embedded in cinder concrete, shall be coated with asphaltum paint.
- B. In runs of conduit or raceway including flexible limit the number of bends between cable access points to a total which does not exceed the maximum specified for the particular system. Where no such maximum is specified, limit the number to four (4) right angle bends or the equivalent thereof.
- C. In each conduit or raceway assigned for the future pulling in of wires, include a nylon drag cord. In raceways 2" trade size and larger, the cord shall be pulled in utilizing a suitable brush, followed by an 85% diameter ball mandrel ahead of the cord in the pulling assembly. In the event that obstructions are encountered, which will not permit the drag cord to be installed, the blocked section of raceway shall be replaced and any cutting and patching of the structure involved in such replacement shall be included as part of the electric work.
- D. Circuitry shall be arranged such that conductors of one feeder or circuitry carrying "going" current are not separated from conductors of the same feeder or circuitry carrying "return" current by any ferrous or other metal. Where not within raceways, all "going" and "return" current conductors of one feeder or circuit shall be laced together so as to minimize induction heating of adjacent metal components.
- E. Sleeves used where circuitry is to penetrate waterproof slabs, decks and walls, shall be of a type selected to suit the water condition encountered in the field.

END OF SECTION

THIS PAGE INTENTIONALLY LEFT BLANK

SECTION 31 00 00

EARTHWORK

PART 1 - GENERAL

1.1 DESCRIPTION

- A. Provide facilities, labor, materials, tools, equipment, appliances, transportation, supervision, and related work necessary to complete the work specified in this section, and as shown on the Drawings.
- B. Work performed under this Section of the Specifications shall be subject to the General Conditions, Supplementary Conditions and Division 01 General Requirements [Division 1 - General Provisions] of the Contract Documents.
- C. The work of this section includes but is not necessarily limited to:
 - 1. Excavation, fill, and backfill, as indicated or required, including compaction
 - 2. Excavation, as required, to the lines and grades indicated on the Drawings
 - 3. Excavation and onsite disposal of unsuitable or excess materials. Excavation shall include removal and satisfactory disposal of all unclassified material encountered throughout the site.
 - 4. Rough grading, including placement, moisture conditioning, and compaction of fills and backfill
 - 5. Placement of base and subbase course materials under structures, pavements, slabs, and footings, including compaction
 - 6. Trench excavation, bedding, and backfill for structures, foundations, and utilities, including compaction
 - 7. The removal, hauling and stockpiling of suitable excavated materials for subsequent use in the work. Stockpiling shall include protection to maintain materials in a workable condition
 - 8. Rehandling, hauling, and placing of stockpiled materials for use in refilling, filling, backfilling, grading, and such other operations
 - 9. Protection and preservation of all existing buildings, pavements, and utilities to remain
 - 10. Furnishing and installing all sheeting, shoring, and bracing of structural and trench excavations and its satisfactory removal, unless otherwise directed to have it remain in place
 - 11. Environmental controls
 - 12. Providing products in sufficient quantities to meet the project requirements
 - 13. Providing adequate pumping and drainage facilities to keep the work area sufficiently dry
 - 14. Obtaining all required permits, licenses, and approvals from appropriate municipal and utility authorities, prior to commencement of the work of this Section, and paying costs incurred therefrom

- D. Provision of facilities, labor, materials, tools, equipment, appliances, and related work necessary to provide and maintain erosion control during construction operations. All erosion control measures shall be installed prior to earthwork operations and shall be maintained according to plans and other sections of the specifications.

- 1. Refer to Section 31 25 00 — EROSION AND SEDIMENTATION CONTROLS

- E. Contractor shall be responsible for notifying all affected utility companies before starting work. Comply with the requirements of the "Dig Safe" Utilities Underground Damage Prevention System.

1.2 RELATED SECTIONS

- A. Carefully examine the Contract Documents for requirements which affect the work in this Section. Other Specification Sections which directly relate to the work of this Section include, but are not limited to, the following:

- 1. Section 01 89 00 — SITE CONSTRUCTION PERFORMANCE REQUIREMENTS
 - 2. Section 31 10 00 — SITE CLEARING
 - 3. Section 31 25 00 — EROSION AND SEDIMENTATION CONTROLS
 - 4. Section 33 39 00 — SANITARY UTILITY SEWERAGE STRUCTURES
 - 5. Section 33 40 00 — STORM DRAINAGE UTILITIES

1.3 REFERENCE STANDARDS

- A. References herein are made in accordance with the listed specific standards of the following organizations and work under this Section shall conform to the latest edition, unless modified by these Specifications.

- 1. American Association of State Highway and Transportation Officials (AASHTO):
 - a. T11 — Standard Method of Test for Materials Finer Than 75-pm (No. 200) Sieve in Mineral Aggregates by Washing.
 - 2. ASTM International (ASTM):
 - a. D422 (2007) Standard Test Method for Particle-Size Analysis of Soils
 - b. D1557-12 Standard Test Methods for Laboratory Compaction Characteristics of Soil Using Modified Effort
 - c. D5268-10 Standard Specification for Topsoil Used for Landscaping Purposes
 - 3. American Concrete Institute (ACI):
 - a. 229R-13 Report on Controlled Low-Strength Materials

- B. Rhode Island Department of Transportation Standard Specifications for Road and Bridge Construction — latest edition (RIDOT Standard Specification)

1.4 LAWS AND REGULATIONS

- A. Work shall be accomplished in accordance with regulations of local, county, state and federal agencies or utility company standards as they apply.

1.5 QUALITY ASSURANCE

- A. The Owner may retain and pay for the services of an independent testing and inspection firm and/or a Geotechnical Consultant to perform on-site observation and testing during the various phases of the construction operations. The scope of services will be determined by the Owner and the independent testing and inspection firm and/or the Geotechnical Consultant, and results will be provided to the Contractor. The Owner reserves the right to modify or waive the services of the independent testing and inspection firm and/or the Geotechnical Consultant. The services of an independent testing firm and/or Geotechnical Consultant may include, but not necessarily be limited to, the following:
 - 1. Observation during excavation and dewatering of building areas and controlled fill areas.
 - 2. Laboratory testing and analysis of fill materials as specified herein and proposed by the Contractor for incorporation into the Work.
 - 3. Observation of construction and performance of water content, gradation and compaction tests at a frequency and locations that the independent testing and inspection firm and/or the Geotechnical Consultant may require. The results of these tests will be submitted to the Owner, Engineer, and Contractor on a timely basis so that action can be taken to remedy indicated deficiencies. During the course of construction, the independent testing and inspection firm and/or the Geotechnical Consultant will advise the Owner in writing, if at any time in their opinion, the Work hereunder is of unacceptable quality. Failure of independent testing and inspection firm and/or the Geotechnical Consultant to give notice, shall not excuse the Contractor from latent defects discovered in his work.
- B. The Contractor shall make provisions for allowing observations and testing of Contractor's work by the independent testing and inspection firm and/or the Geotechnical Consultant.
 - 1. The presence of the independent testing and inspection firm and/or the Geotechnical Consultant does not include supervision or direction of the actual work of the Contractor, and his employees or agents. Neither the presence of the independent testing and inspection firm and /or the Geotechnical Consultant, nor any observations and testing performed by them, nor failure to give notice of defects shall excuse the Contractor from defects discovered in his work.
- C. Costs related to retesting due to unacceptable qualities of work and failures discovered by testing shall be paid for by the Contractor at no additional expense to Owner, and the costs thereof will be deducted by the Owner from the Contract Sum.
- D. Whenever floodplain or wetland compensation areas are designated on the plans, grading elevations are to be considered critical to the volumetric calculations and shall be constructed by the Contractor in strict conformance with the indicated grades.

1.6 SUBMITTALS

- A. Submit, in an airtight container for the testing laboratory, a 50-pound sample of each type of off- site fill material that is to be used at the site. Submit samples a minimum of one week prior to use of proposed material at the site. Submit samples to the testing laboratory and/or the Geotechnical Consultant (copy of these transmittal forms shall be simultaneously sent to Engineer) or if no testing laboratory and/or Geotechnical Consultant is identified, then the Engineer shall be the recipient of the samples. Use of these proposed materials by the Contractor prior to testing and approval shall be at the Contractor's risk.
- B. The Engineer will determine the suitability of all materials.
- C. Submit the name of each material supplier and specific type and source of each material. Any change in source throughout the project will require approval of the Owner or Engineer.
- D. For use of geotextile fabrics or geogrids, submit manufacturer's product data including material properties for approval by the Engineer.

1.7 COORDINATION

- A. Prior to start of earthwork the Contractor shall arrange an on-site meeting with the Engineer, the Owner's Representative, the independent testing firm, and/or the Geotechnical Consultant for the purpose of establishing the Contractor's schedule of operations and scheduling observation and testing procedures and requirements.
- B. As construction proceeds, the Contractor shall be responsible for notifying the Owner and Engineer prior to the start of earthwork operations requiring observation and/or testing.

1.8 SUBSURFACE SOIL DATA

- A. Refer to Geotechnical Report titled 'Proposed Education Center and Event Pavilion' prepared by LAHLAF Geotechnical Consulting, Inc. (December 3, 2019).
- B. Review available logs of borings, test pit logs, jar soil samples, records of explorations and other pertinent data for the site. After obtaining Owner's permission, take whatever additional subsurface explorations deemed necessary at no expense to the Owner.
- C. Boring logs, soil samples may be examined upon written request to the Geotechnical Engineer.
- D. Subsurface soil data is provided for general information and is accurate only at the particular locations and times the subsurface explorations were made. It is the Contractor's responsibility to make interpretations and to draw conclusions based on the character of materials to be encountered and the impact on his work based on his expert knowledge of the area and of earthwork techniques.

- E. The Drawings in the geotechnical report showing existing ground elevations are only for whatever use the Contractor may make of them with no responsibility on the part of the engineers, surveyors, the Owner, the Engineer, and/or their representatives for the accuracy and/or the reliability of the information given.
- F. If a potential conflict exists between the Geotechnical Report and these technical Specifications, the Contractor shall, immediately upon its discovery, request clarification from the Owner's Representative or the Engineer.

PART 2 - PRODUCTS

2.1 SUBGRADE

- A. Subgrade is the material in excavation (cuts) and fills located below subbase, base course layer for slabs, sidewalks, pavement, and other improvements.

2.2 COMMON / ORDINARY FILL

- A. Common/Ordinary Fill should have a plasticity index of less than 6 and should meet the gradation requirements shown below. Common/Ordinary Fill should be compacted in maximum 9-inch loose lifts to at least 95 percent of the Modified Proctor maximum dry density (ASTM D1557), with moisture contents within 2(+/-) percentage points of optimum moisture content.

<u>SIEVE</u> <u>(ASTM D422)</u>	<u>Percent Passing by Weight</u>
6 inches	100
1 inch	50-100
No. 4	20-100
No. 20	10-70
No. 60	5-45
No. 200	0-20

2.3 GRAVEL, SAND GRAVEL FILL.

- A. Gravel and sand gravel fill shall consist of inert material that is hard, durable stone and coarse sand, free from loam, clay, surface coatings and deleterious materials, and shall conform to the following gradation:

<u>SIEVE</u> <u>(ASTM D422)</u>	<u>Percent Passing by Weight</u>
*	100
½ inch	50-85
No. 4	40-75
No. 10	30-60
No. 40	10-35
No. 100	5-20**
No. 200	0-8

*Four (4) inches when placed as base course below slabs and pavement, and pipe bedding and backfill up to 24" above pipe; elsewhere, maximum stone sizes should be (2/3) the loose lift thickness.

**The amount passing the No. 100 sieve should be between 40% to 70% of that amount passing the No. 40 sieve.

2.4 STRUCTURAL FILL

- A. The Structural Fill should have a plasticity index of less than 6 and should meet the gradation requirements shown below. Structural Fill should be compacted in maximum 9-inch loose lifts to at least 95 percent of the Modified Proctor maximum dry density (ASTM D1557), with moisture contents within 2(+/-) percentage points of optimum moisture content.

<u>SIEVE</u> <u>(ASTM D422)</u>	<u>Percent Passing by Weight</u>
3 inches	100
1 ½ inch	80-100
½ inch	50-100
No. 4	30-85
No. 20	15-60
No. 60	5-35
No. 200*	0-10

*0-5 for top 12 inches under sidewalks and exterior slabs

2.5 SAND

- A. Sand shall consist of clean, inert, hard, durable grains of quartz or other hard, durable rock, free from loam or clay, surface coatings and deleterious materials.
 - 1. The allowable amount of material passing a No. 200 sieve as determined by AASHTO-T11 or ASTM D422 shall not exceed 10 percent by weight. The maximum particle size shall be 1/4-inch (i.e., 100 percent passing the No. 4 sieve).
 - 2. In addition to the above criteria when sand is used for bedding concrete pavers and for utility bedding it shall conform to the following gradation:

<u>Sieve</u> <u>(ASTMD422)</u>	<u>Percent Passing</u> <u>by Weight</u>
No. 4	100
No. 8	80-95
No. 16	55-85
No. 50	0—35
No. 200	0-5

2.6 CRUSHED STONE

- A. Crushed Stone shall be composed of durable crushed rock consisting of angular fragments, free from a detrimental quantity of thin, flat, elongated pieces or shall be durable crushed gravel stone obtained by artificial crushing of gravel boulders or fieldstone.
 - 1. The crushed stone shall be free from clay, loam, or deleterious material.
 - 2. Crushed stone shall conform to the following gradation:

Sieve Size	Percent Passing by Weight	
	1-1/2-inch Stone	2-inch Stone
2 inch	100	90 - 100
1-1/2 inch	95 - 100	
1-1/4 inch		25 - 50
1 inch	35 - 70	
3/4 inch	0 - 25	0 - 15
1/2 inch		0 - 5

- B. Dense-graded Crushed Stone for Subbase and Base shall conform to the following gradation:

Sieve Size	Percent Passing by Weight
	2-inch Stone
2 inch	100
1-1/2 inch	70 - 100
3/4 inch	50 - 85
No. 4	30 - 55
No. 50	8 - 24
No. 200	3 - 10

2.7 BLAST ROCK FILL

- A. Blast Rock Fill shall be well-graded blasted rock formed and processed when on-site rock is removed by blasting or chipping methods, with a maximum size hereinafter specified. Well-graded means that at least twenty-five percent (25%) is less than six inches (6") in size, and at least ten percent (10%) is less than three-quarters inch (3/4") in size. The Contractor shall vary drilling and blasting procedures as needed and/or select materials sources in order to meet these gradation requirements.
- B. Choke Stone shall be hard, durable, clean, rock with a maximum rock diameter of nine inches (9") and shall conform to the following gradation:

Sieve Size	Percent Passing by Weight
	9 inches
6 inches	75 - 100
2 inches	70 - 85
3/4 inches	45 - 60
No. 4	15 - 30
No. 40	5 - 15
No. 200	0 - 10

2.8 STONE FILL

- A. Stone Fill shall be hard, durable, clean, washed rock with a minimum diameter of 1-1/2 inches and a maximum diameter of 3 inches with void ratio of 30 to 40 percent.

2.9 STONE FOR PIPE ENDS

- A. Stone for pipe ends and energy dissipaters shall be sound, durable rock, angular in shape. Rounded stones, boulders, sandstone, or similar stone or relatively thin slabs will not be acceptable. The majority of the larger stones shall weigh not less than 50 pounds nor be less than 1.4 ft. long, 0.5 ft. wide, and 0.5 ft. in height. Each larger stone shall weigh not more than 125 pounds nor be more than 2.0 ft. long, 0.8 ft. wide, and 0.8 ft. in height and at least 50 percent of the larger stone volume shall consist of stones weighing not less than 75 pounds nor be less than 1.6 ft. long, 0.6 ft. wide, and 0.6 ft. height. The remainder of the stones shall be so graded that when placed with the larger stones the entire mass will be compact.

2.10 FILTER FABRIC AND GEOTEXTILES

- A. Filter Fabric used with riprap, stone for pipe ends, slope paving, or channel paving (grouted or ungrouted) shall be as Mirafi 600X or approved equivalent.
- B. Filter Fabric used for prevention of soil intrusion into drains or to assist in stabilizing soil subgrades shall be Mirafi 140N or approved equivalent.
- C. Filter fabric in drainage recharge systems, underdrain systems between crushed stone and granular soils, leaching areas, or where indicated on the plans shall be Mirafi 140N or approved equivalent.

2.11 CONTROLLED DENSITY FILL

- A. Controlled low strength material or controlled density fill shall be a cement concrete backfill material that flows like a liquid, supports like a solid when cured, and levels without tamping or vibrating to reach 100 percent compaction. The material shall be used primarily as a backfill in lieu of compacted fill. The material shall be proportioned to yield a 28-day minimum compressive strength of 200 pounds per square inch. The material shall be produced and installed in accordance with ACI 229R-13, with a mix formulation to be approved by the Engineer or Geotechnical Consultant prior to placement of the material in the project.

PART 3 - EXECUTION

3.1 USE OF MATERIALS

- A. Use of materials shall be as described below and as shown on the plans. Combinations or layering of materials may be necessary in certain instances such as for detention embankments, subsurface disposal areas, and riprap walls as examples.

1. Common/Ordinary Fill, Granular Fill: Use common/ordinary fill for general grading as backfill, and as embankment fill in areas outside the building and pavement limits. Stones larger than twelve inches (12") shall be removed prior to compaction.
2. Gravel, Sand Gravel Fill: Use for pipe bedding backfill and backfill below pavement and slab as base course layer. Use for material placed "in the wet". Use for backfill behind retaining walls and retaining structures. Use for pipe and utility bedding.
3. Structural Fill: Use for fill placed within the footprint of proposed buildings.
4. Sand: Use for conduit bedding and initial backfill, and gas line bedding and backfill. Use for bedding and backfill of direct burial cables and/or flexible piping. Use for bedding and filling joints for concrete unit pavers.
5. Crushed Stone: Use crushed stone as a filter material around perforated pipe and as bedding for piping under wet subgrade conditions.
6. Blast Rock Fill and Choke Stone: Blast rock fill may be placed to within forty-two (42") of finish grade in pavement and building floor slab areas, and to within eighteen inches (18") of utility line inverts and bottom of foundations. The first lift over the top of rock fill shall be a choke stone layer eighteen inches (18") thick. Compaction shall be by minimum of four (4) passes of a self-propelled vibratory drum roller in each direction (i.e., north-south and east-west). The minimum weight of the drum shall be ten thousand pounds (10,000 lbs.). Blast Rock shall not be placed within a five foot (5') horizontal distance on either side of proposed utility lines. The intent is to leave a zone of Structural Fill that can later be excavated for installation of utilities. Also, large rock fragments shall be kept away from utility pipes.
7. Filter Fabric: Filter Fabric is to be used as a filter barrier between drainage recharge systems, underdrain systems, wastewater absorption systems, and between natural earth material and backfill or other materials to assist in stabilizing soil subgrades.
8. Stone for Pipe Ends: Use stone for erosion prevention at pipe ends of drainage pipes, energy dissipaters, stilling basins and at inlets to drainage structures.
9. Controlled Low Strength Material or Controlled Density Fill: Shall be used for trench backfill, anti-flotation bases, and/or lightweight backfill.

3.2 EXCAVATION — GENERAL

A. General Definitions

1. Unclassified Materials - Unclassified excavation includes the satisfactory removal and disposal of all materials (except contaminated materials defined below) encountered regardless of the nature of the materials and shall be understood to include, but not be limited to, blast rock, bedrock, earth, hardpan, fill, foundations, pavements, curbs, piping, railroad track and ties, cobblestones, footings, bricks, concrete, abandoned drainage and utility structures, and debris. Drilling, blasting, excavation, and disposal of rock shall be considered unclassified excavation and shall be included as a part of the Contract Price, with no separate payment items for its excavation and handling.

2. Classification of Materials

- a. Unclassified. Unclassified excavation shall comprise and include the satisfactory removal and disposal of all materials encountered regardless of the nature of the materials, except for rock excavation and contaminated materials as defined below, and shall be understood to include, but not be limited to, earth, hardpan, fill, foundations, pavements, curbs, piping, railroad track and ties, cobblestones, footings, bricks, concrete, abandoned drainage and utility structures, and debris.
- b. Rock Excavations. Rock is defined for payment purposes as stone or hard shale in original ledge, boulders over two cubic yards (2 yd³) in volume in open areas, and one cubic yard (1 yd³) in volume in trenches, and masonry or concrete that cannot be broken or removed by normal job equipment (power shovels, scoops, or D-8 bulldozers with ripper attachment) without the use of explosives or drills. The classification does not include materials that can be removed by means other than drilling and blasting or drilling and wedging. Quantities shall be measured in their original position to the limits of clearly defined vertical construction lines and to the depth required for the defined construction. Payment will be at the unit prices stated in the Contract. Payment limit lines for rock excavation in trench will be 18 inches measured horizontally and 12 inches measured vertically below the pipe, duct bank or structure. Pay limit lines for open rock excavation will be measured 12 inches below the bottom of normal excavation limits.

3. Contaminated Materials

- a. The Contractor shall be familiar with the State of Rhode Island Department of Environmental Management (RIDEM) regulations governing the management of hazardous materials, hazardous waste, petroleum, used petroleum and solid waste when conducting earthwork operations
- b. In general, a hazardous waste (contaminated with oil or hazardous materials) is a waste or combination of wastes which, because of its quantity, concentration, physical, chemical or infectious characteristics, may cause, or significantly contribute to, an increase in mortality or an increase in serious irreversible or incapacitating reversible illness or pose a substantial present or potential hazard to human health, safety, or welfare, or to the environment when improperly stored, treated, transported, or disposed of, or otherwise managed.
- c. The Contractor shall immediately halt soil movement activities and notify the Owner if visual, olfactory, or other evidence suggests that soils may be contaminated with oil or hazardous materials. Contractor shall provide reasonable assistance to Owner and to Owner's Representative for access to potential contamination areas for proper assessment of hazardous conditions.
- d. The Owner will contact an environmental professional (such as a Licensed Site Professional) to test any earth materials suspected of containing hazardous waste. The results shall be evaluated by the environmental professional and compared with reporting thresholds found in the RIDEM Rules and Regulations for the Investigation and Remediation of Hazardous Materials Releases. The Owner will inform the Contractor of the laboratory test results as soon as possible and discuss the possible soil management, disposal, and recycling options available. Contaminated soils shall be managed and handled in compliance with the referenced state & federal regulations, guidelines, and policies. Time and expenses associated with contaminated soils shall be negotiated between the Contractor and

the Owner prior to the start of the soil management, soil disposal, and recycling work. Owner reserves the right to negotiate and contract with other entities for remedial work and, in that event, this Contractor shall make reasonable accommodations for other entities to perform this work.

- e. [Design Engineer Note: Although there is no evidence of oil or hazardous material,] there is a possibility of the presence of such wastes on this site. Appropriate testing, as recommended by an environmental professional shall be accomplished to assess the potential presence of oil or hazardous material. Earth material shall not be removed from the site unless on-site reuse is not possible.
- f. Proper documentation of legal disposal of hazardous materials handled by this Contractor shall be provided by the Contractor to the Owner, Engineer, and review authorities.
[Design Engineer Note: To be determined on a site-by-site basis prior to the start of the project.] Additional guidance for possible disposal activities can be found in the Department of Environmental Protection's Policy #COMM-97-001, [Reuse and Disposal of Contaminated Soil at Massachusetts Landfills.]
- g. Unless specifically identified as contaminated material under referenced statues and as defined above, as judged by the Engineer, excavated materials shall be considered unclassified as defined in Item 1., above.

B. Site General Requirements

- 1. Control the grading so that ground is pitched to prevent water from running to excavated areas, damaging other structures, or adjacent properties.
- 2. Where soil has been softened or eroded by flooding, equipment, traffic, or placement during unfavorable weather, or other conditions, it shall be removed and replaced by the Contractor with suitable material, and at no cost to the Owner.
- 3. Exercise care to preserve the material below and beyond the lines of excavation. Where excavation is carried out below indicated grade or beyond the lines of excavation, Contractor shall backfill and compact the over excavation with structural fill to the indicated grade, at no additional cost to the Owner and at the direction of the Engineer.
- 4. Provide sheeting, shoring and bracing to complete and protect all excavated areas, as required for safety and compliance with OSHA. Costs for sheeting, shoring, and bracing shall be included as a part of the Contract Price for completing the work and Owner will make no separate payment for this work.
- 5. Excavated materials unsuitable for reuse, surplus excavated rock, and surplus excavated soil not used to fulfill requirements of the Contract, shall become the property of the Contractor and shall be removed from the site in accordance with the regulations and requirements of all municipalities or agencies having jurisdiction over the disposal sites and the route between the project and the disposal sites.
- 6. Limits of excavation shall be such that all unsuitable material shall be removed to firm natural ground in the manner specified below:
 - a. In building areas, unsuitable materials shall be removed to a distance of two feet (2') beyond the building lines or within the area defined by a one horizontal to one vertical (1h:1v) line sloping down from outside bottom edge of exterior footings to firm natural ground, whichever is greater.
 - b. Limits of unsuitable material excavation also apply to areas below exterior column footings.
 - c. All abandoned pipes within building areas shall be removed and the excavations shall be properly backfilled.

7. Unsuitable materials which are classified as organics such as peat, trash, fill, stumps, debris, material determined to be hazardous, and topsoil and subsoil when determined by Engineer to be unacceptable for incorporation into the work.
Existing topsoil, subsoil, and existing fill are unsuitable for foundation and slab support and should be removed from the proposed building areas prior to foundation and slab construction.
8. Under pavement areas, existing fill shall be densified in place and shall not be excavated.
9. Suitable material, as determined by the Engineer, may be reused on the site provided it meets the gradation requirements for the given materials as specified under 2.0 MATERIALS.
10. The Contractor shall not over-excavate below proposed design grades for the purpose of obtaining borrow for use off-site.

C. Proof Rolling

1. Prior to placing compacted fills, the Contractor shall proof roll the natural grades to remain. Proof rolling shall be done with a minimum 6 passes of a self-propelled vibratory roller having a drum weight of at least 10,000 pounds and a dynamic force of 20,000 pounds. Where materials of low density are indicated by rutting or weaving under the compactor, the Contractor may be required to make up to three (3) additional complete passes of the area with the compactor as determined by the Engineer. The cost of all proof rolling shall be included in the Contract Price. If materials of low density are encountered that cannot be compacted to the extent necessary to support the proposed embankment fills as determined by the Engineer, the Contractor shall remove those materials and replace them with compacted fill.
2. Alternately, an initial layer of fill may be allowed to form a working platform. The need, manner of construction, and thickness of such a layer shall be subject to approval of the Engineer and the layer will be permitted only where the lack of support is, as determined by the Engineer, not due to deficient ditching, grading or drainage practices, or where the embankment could be constructed in the approved manner by the use of different equipment or procedures. Thickness of up to eighteen inches (18") may be permitted for such a layer.

3.3 SHEETING SHORING AND BRACING

A. General

1. Whenever sheeting, shoring, and bracing will be required, it shall be furnished and installed by the Contractor in accordance with State and Federal guidelines, regulations and the recommendations of the structural engineer and/or geotechnical engineer engaged by the Contractor.
2. When required, the Contractor shall engage licensed professional structural engineer and/or geotechnical engineer to design sheeting, shoring, and bracing. These engineers shall be licensed in the state where the work is occurring, and they shall prepare designs for the sheeting and bracing.
3. Submit the sheeting and bracing designs to the Owner and the Engineer for the project record. The sheeting and bracing plans and calculations shall bear the professional seals and signatures of the Contractor's engineers. These plans and calculations shall be submitted prior to the start of work.

4. The Contractor shall furnish and install the required sheeting, shoring and bracing in accord with the submitted designs. The Contractor shall include the costs for this work in his bid price for the project. No additional or separate compensation will be allowed.

3.4 TRENCH EXCAVATION

- A. Excavate as necessary for all drainage pipes, utilities, and related structures and appurtenances, and for any other trenching necessary to complete the work.
- B. Definitions:
 1. Trench shall be defined as an excavation of any length where the width is less than twice the depth and where the shortest distance between payment lines does not exceed ten feet (10'). All other excavations shall be defined as open excavations.
 2. The words "invert" or "invert elevation" as used herein shall be defined as the elevation at the inside bottom surface of the pipe or channel.
 3. The words "bottom of the pipe" as used herein shall be defined as the base of the pipe at its outer surface.
- C. In general, machine excavation of trenches will be permitted with the exception of preparation of pipe beds which will be hand work. Excavate by hand or machine methods to at least six inches (6") below the bottom of pipe or as shown on the Drawings. Excavation to final grade shall be made in such a manner as to maintain the undisturbed bearing character of the soils exposed at the excavation level.
- D. Utilities or piping shall not be laid directly on boulders, cobbles, or other hard material. This material shall be removed to a minimum of six inches (6") below the bottom of pipe at all points and backfilled or compacted as specified.
- E. Remove unsuitable material encountered at subgrade elevations, backfill with material specified herein and as otherwise indicated on the Drawings, specified, or directed. Compact as specified with approved compactors.
- F. In general, the width of trenches shall be kept to a minimum and in the case of piping shall not exceed the sum of the pipe's outside diameter plus 2'-0" to at least twelve inches (12") above the pipe.

3.5 ROCK EXCAVATION

- A. Definitions
 1. Rock is defined for payment purposes as stone or hard shale in original ledge, boulders over two cubic yards (2 yd³) in volume in open areas, and one cubic yard (1 yd³) in volume in trenches, and masonry or concrete that cannot be broken or removed by normal job equipment (power shovels or track mounted excavator without the use of explosives or drills).
 2. The definition does not include materials that can be removed by means other than drilling and blasting or drilling and wedging.

B. General

1. When rock is encountered, such material shall be removed to the clearance limits set forth in these Specifications.
2. Payment for rock excavation shall be made in accordance with Item 3.03A.1.
3. Rock excavation shall be performed to eliminate water pockets in the excavated rock subgrade. Contractor shall provide dewatering as required to keep the excavated rock subgrade dry until earthwork operations are complete.

C. Cross-Sectioning and Measurement

1. When rock is encountered, the rock shall be uncovered and exposed, and the Engineer shall be notified in writing by the Contractor before blasting work proceeds. Quantities shall be based on measurements of rock in their original position and to the limits of clearly defined vertical and horizontal construction lines required for the defined construction.
2. The rock shall then be measured, quantities established, and payment amounts determined.
3. Excavation of material in question before agreement by the Engineer as to the character of the material, or failure to notify the Engineer, or failure to take measurements will forfeit the Contractor's right to payment for rock excavation.
4. The quantity of rock to be removed shall be based on the limits established under the Clearance Limits specified below.
5. Measurements shall be made by a registered surveyor, paid for by the Contractor and approved by the Engineer.
6. Cross-sectioning and measuring shall not be required when the payment for rock excavation is included as a part of the lump sum Contract Price.

D. Clearance Limits

1. Foundations and Slabs: Within the limits of the concrete lines as defined by the working plans or as otherwise approved by the Engineer, plus twelve inches (12") outside the vertical concrete lines and twelve inches (12") below base.
2. Utility Trenches: All parts of pipe, valves, and fittings to a depth of six inches (6") below the bottom of the bell and for a width equal to the outside diameter of the pipe, plus fifteen inches (15") beyond the outside diameter on each side, provided that overlapping computed volumes of any ledge or boulder excavation shall be paid for only once.
3. Paved Areas: To the underside of the subbase.
4. Site Structures: Twelve inches (12") outside of structure all around.
5. Lawn areas and shrub planting areas: To a depth of eighteen inches (18") below finished grade.
6. Planting areas for trees over two inches (2") in caliber size: To depth of thirty-six inches (36") below finished grade and for a radius of 3 feet (3') around each tree, except volumes in radius areas shall not overlap.
7. Any foreseen rock or boulder encountered, as defined above, which must be removed for construction of the work defined on the plans or in modification thereto, shall be measured in its original position to the limits of clearly defined vertical construction lines and to the depth required for the defined construction.

E. Reuse of Excavated Rock

1. Riprap
 - a. Excavated rock may be used as riprap, for construction of stone masonry walls, and for sloped riprap for retaining walls, provided that the rock is judged to be adequate quality by the Owner's Representative and the rock is sufficiently broken to meet gradation requirements established for the intended use.
2. Fills
 - a. Reuse of excavated rock for fill materials shall require prior approval of the Owner's Representative and shall require compliance with gradation requirements for the specific type of fill for which it is being used.

F. Rock Subgrades under Building Footings and Paved Areas

1. Excavation of rock under footings and paved areas shall include the removal of all loose material to the top of sound bedrock that is acceptable to the Owner's Representative. Sound bedrock is defined as hard, intact rock that cannot be excavated with a track mounted excavator.
2. Rock surface for footings shall have a maximum slope of four (4) horizontal to one (1) vertical.
3. Rock excavations for footings carried below design grades shall be backfilled by placement of concrete with same strength as footing at the Contractor's cost. At the discretion of the Structural Engineer of Record (SER), footings could be dropped below design elevation onto competent rock.

3.6 PREPARATION OF EXCAVATION BOTTOMS

A. General Rock Subgrade Areas

1. Rock surfaces to receive backfill shall have a maximum slope of four (4) horizontal to one (1) vertical.

B. Building and Pavement Areas

1. Loose rock is covered with 6 inches (6") of crushed stone or choke stone; and
2. Prior to placing crushed or choked stone, the area is rolled with a heavy vibratory roller or fully loaded ten-wheel dump truck.
3. Proof-roll subgrade with a vibratory roller or a fully loaded ten-wheeled dump truck. Soft or hard areas and other objectionable material (stumps, wood, organics) shall be excavated and backfilled with compacted structural fill.
4. Prior to the placement of blast rock fill over a bedrock subgrade, voids in the rock surface shall be choked off with appropriately graded choke stone or crushed stone to prevent migration of fines into fractures, and as approved by the Owner's Representative.

C. Subgrades under Proposed Landscape Areas

1. Depth to rock under planting areas shall be a minimum of 48 inches (48") below subgrade elevations. Backfill up to subgrade shall be done with topsoil/loam materials.
2. In lawn areas, scarify subsoil a minimum depth of six inches (6"). Subsoil shall also be

- cleared of debris and stones larger than four inches (4") prior to topsoil spreading.
3. In planting areas, scarify subsoil a minimum depth of six inches (6") below the required root ball excavation prior to placement of plant backfill mixture.

D. Trenches

1. Compaction equipment used in open areas where space permits shall consist of vibratory rollers, fully loaded ten-wheel dump trucks, pneumatic compactors, or other similar equipment.
2. Compaction equipment for fill against foundation walls and in other confined areas shall be accomplished by means of drum-type, power-driven, hand-guided vibratory compactors operating at 2,000 cycles per minute, or by hand-guided vibratory plate tampers

3.7 BACKFILLING AND PLACEMENT OF FILL MATERIALS

A. Site

1. Dewater subgrade areas prior to filling.
2. Compaction by puddling or jetting is prohibited.
3. Control groundwater and surface runoff to minimize disturbance of exposed natural ground surface, previously placed and compacted fill and material being placed.
4. Soil fill moisture shall be maintained at an acceptable working range to allow for proper compaction.
5. Do not place fill on frozen ground.
6. Do not place frozen fill.
7. Place fill in uniform horizontal layers and compact immediately after placement. Where the horizontal layer meets a rising slope, the layer shall be keyed into the slope by cutting a bench during spreading of preceding lift.
8. To the extent that is practical, each layer of fill shall be compacted to the specific density the same day it is placed.
9. Slope fill surfaces at the end of each day to provide for free surface drainage.
10. Protect structures and pipes from damage during backfilling operations. Repair damage at no cost to Owner.
11. Placement of fill shall not begin prior to observation and approval of subgrade conditions by Engineer.
12. Protect foundations, footings, and waterproofing during backfilling. Repair damage at no cost to Owner.
13. Prior to backfilling between foundation wall and sheeting, remove unsuitable material, including rubbish, organic materials, or other debris. Do not commence filling operations until conditions have been observed by Engineer.
14. Backfill shall not be placed against walls until they are braced or have cured sufficiently to develop strength necessary to withstand, without damage, pressure from backfilling and compacting operations.
15. Provide shoring, sheeting, and bracing of excavations as required to assure complete safety against collapse of the earth at the site of excavations. Alternatively, lay back excavations to suitable slope.
16. Upon completion of the work, the final ground surface shall be left in a firm, unyielding, true, uniform condition free from ruts. Repair disturbed areas caused equipment traffic at no cost to Owner.

B. Equipment

1. Compaction equipment used in open areas where space permits shall consist of vibratory rollers, fully loaded ten-wheel dump trucks, pneumatic compactors, or other similar equipment.
2. Compaction equipment for fill against foundation walls and in other confined areas shall be accomplished by means of drum-type, power-driven, hand-guided vibratory compactors operating at 2,000 cycles per minute, or by hand-guided vibratory plate tampers.

C. Blast Rock Backfill — Structure and Foundation Backfilling and Compacting

1. Prior to the placement of blast rock fill over a bedrock subgrade, voids in the bedrock surface shall be choked off with appropriately graded crushed stone or choke stone to prevent migration of fines into fractures as approved by the Owner's Representative.
2. Blast rock fill and crushed stone shall be placed and compacted as indicated below:
 - a. Maximum lift thickness prior to compaction shall be 24 inches (24").
 - b. Material shall be dumped 25 feet behind the fill face and pushed forward to allow mixing and removal of oversized rock and backfilling voids.
 - c. Should the maximum size of blast rock exceed 18 inches (18"), then use a rock rake with teeth spaced at 18 inches (18"), or other means to separate and remove oversized rock.
 - d. Provide a minimum of 18-inch-thick transition zone of choke stone between blast rock fill and granular fill materials. All blast rock fill shall be choked with a transition zone of choke stone, where structural fill is to be placed above or adjacent to it.
 - e. Compact each lift of blast rock fill with a vibratory drum roller or fully loaded ten-wheel dump truck.
 - f. Crushed stone and choke stone placement shall not exceed a maximum lift thickness of 12 inches (12") prior to compaction.

C. Placing Fill

1. Fill sections and embankments shall be constructed of earth, rock, or a mixture of earth and rock deposited in successive lifts. Except as hereinafter permitted, the loose thickness of each lift shall not be more than twelve inches (12") before compaction.
2. Rock fill may be used in deep fill areas, placed to the levels and under the conditions described in Section 2.01K.
3. No rock in excess of six inches (6") in its largest dimension shall be incorporated in the top two-foot (2') layer of embankment immediately below the subgrade.
4. During fill and embankment construction operations, earth moving equipment shall be routed as evenly as possible over the entire width of the work.
5. At the close of each day's work the working surface shall be crowned, shaped, and rolled with smooth steel or pneumatic tired rollers to ensure proper drainage.
6. Prior to placing compacted structural fill below, the slab, the surface of natural ground, shall be proof-rolled with a heavy vibratory drum roller or a fully loaded ten-wheel dump truck. Hard and soft spots shall be excavated and replaced with structural fill or other material acceptable to the Owner's Representative.

7. Where excavations for slab-on-grade extend to weathered fractured or blasted bedrock, the Owner's Representative shall assess the rock surface for the presence of voids and may require placement of a 2 inch to 18-inch layer of choke stone or crushed stone prior to placement of structural fill.
- D. Fills under Parking Areas
1. Paved area subgrades shall be excavated to a minimum of 12 inches (12") beneath required subgrade elevation or existing grade, whichever is lower.
 2. Proof-roll subgrade with a vibratory roller or a fully loaded ten-wheeled dump truck. Soft or hard areas and other objectionable material (stumps, wood, organics) shall be excavated and backfilled with compacted common fill.
 3. Where excavations for pavements extend to weathered, fractured, or blasted bedrock, prepare surface as indicated in Section 3.05B. for building and pavement areas.
 4. A minimum of 12 inches (12") of gravel base course shall be provided between subgrade and the bottom of the bituminous surface.
- E. Subgrades under Proposed Landscape Areas
1. Fills under tree and shrub planting areas shall be backfilled with topsoil/loam materials.
- F. Buildings
1. Prior to the placement of blast rock fill over a bedrock subgrade, voids in the rock surface shall be choked off with appropriately graded choke stone or crushed stone to prevent migration of fines into fractures, as approved by the Owner's Representative.
 - a. Blast rock fill and crushed stone shall be placed and compacted as indicated below.
 2. Blast Rock Fill Placement and Compaction:
 - a. Maximum lift thickness prior to compaction shall be 24 inches (24").
 - b. Material shall be dumped 25 feet behind the fill face and pushed forward to allow mixing and removal of oversized rock and backfilling voids.
 - c. Should the maximum size of blast rock exceed 18 in., (18") then use a rock rake with teeth spaced at 18 in. (18") or other means to separate and remove oversized rock.
 - d. Provide a minimum of one-foot-thick transition zone of crushed stone between blast rock fill and granular fill. All blast rock fill shall be choked with a transition zone of crushed stone, where granular fill is to be placed above it.
 - e. Compact each lift of blast rock fill with a vibratory drum roller or a fully loaded ten-wheel dump truck.
 3. Crushed Stone Placement and Compaction:
 - a. Maximum lift thickness prior to compaction shall be 12 in. (12").
 4. Structural Fill: A minimum of 24 inches (24") of compacted structural fill shall be placed in maximum 9-inch (9") lifts immediately below the slabs.

3.8 TRENCH BACKFILL

A. General

1. Trenches shall be backfilled as soon as practicable with suitable approved materials. All trench backfilling shall be done with special care, in the following manner and as the Engineer may direct from time to time.
2. Backfill material for pipe bedding shall be deposited in the trench, uniformly on both sides of the pipe, for the entire width of the trench to the spring-line of the pipe. The backfill material shall be placed by hand shovels in layers not more than 6 inches (6") thick in loose depth and each layer shall be thoroughly and evenly compacted by tamping on each side of the pipe to provide uniform support around the pipe.
3. Trench backfilling shall be placed so as not to disturb the previously installed pipes, utilities, concrete, and other work within and near the trench. The moisture content of the backfill material shall be such that proper compaction will be obtained. Backfill of trenches within areas of pavement construction shall be made in controlled compacted lifts extending to grades required to establish the proper pavement base courses.
4. In backfilling trenches, each layer of backfill material shall be adequately compacted in such a manner as to provide the required bearing value, so that paving can proceed immediately after backfilling is completed.
5. Any trenches or excavations improperly backfilled, or where settlement occurs, shall be reopened to the depth required for proper compaction, then refilled and compacted with the surface restored to the required grade and condition, at no additional cost to the Owner.
6. During filling and backfilling operations, pipelines will be checked to determine whether any displacement of the pipe has occurred. If the inspection of the pipelines shows poor alignment, displacement of pipe, or any other defects, the condition shall be remedied by removal, realignment, and backfill of the pipe, in a manner satisfactory to the Engineer at no additional cost to the Owner.

B. Embedment

1. The type of materials to be used in bedding and backfilling shall conform to the details shown on the Drawings and the following:
 1. Embedment materials are those used for bedding, haunching and initial backfill. Perform in accordance with ASTM D2321. The following will describe the soils:
 - a. Class I - Angular crushed stone or rock, dense or open graded with little or no fines (3/4-inch stone size) (to be used in wet conditions or where shown on the Drawings).
 - b. Class II - Clean, coarse-grained gravel, with a maximum stone size of 1-1/2 inches.
 - c. Embedment materials shall be free from lumps of frozen soil or ice when placed. Embedment materials shall be placed and compacted at optimum moisture content.
2. Foundation: A stable utility foundation of Class I or II material must be provided to ensure proper line and grade is maintained. Unsuitable foundations such as organics, soft clay, and other soft materials must be removed, and the material stabilized. Unsuitable or unstable foundation materials shall be undercut and replaced with a suitable bedding material of Class I or Class II (see 3.08B.5.), placed in 6-inch (6") lifts. The Engineer may approve other methods of stabilization, such as the use of geotextiles.

3. Bedding: Provide a stable and uniform bedding for the pipe and any protruding features of its joints and/or fittings. The bedding for the middle 1/3 of the pipe outside diameter should be loosely placed so that the pipe conforms to the trench. The remainder of the bedding at the base of the trench shall be compacted to a minimum of 95 percent modified proctor density as determined by ASTM D1557. Class I or Class II materials are suitable for use as bedding.
4. Haunching: Proper haunching provides a major portion of the pipe's strength and stability. Care must be exercised to insure placement and compaction of the embedment material in the haunches. For larger diameter pipes (greater than 30" in diameter), embedment materials should be worked under the haunches by hand. Haunching materials may be Class I or Class II materials and shall be placed and compacted in 6-inch (6") maximum lifts, compacted to 95 percent modified proctor density.
5. Initial Backfill: Initial backfill materials are required for a minimum of 3/4 of the pipe diameter. The initial backfill shall be from the pipe's spring line to 12 inches above the pipe to provide protection for the pipe from construction operations during placement of the final backfill and protect the pipe from stones or cobbles in the final backfill.
 - a. Class I materials must be used in wet trenches and Class bedding and haunching materials shall be used.
 - b. Class II materials shall be used unless noted otherwise or wet conditions are encountered. The material shall be compacted in 6-inch (6") lifts to 95 percent modified proctor density (ASTM D1557).
 - c. Flooding or jetting as a procedure for compaction are not allowed.
6. Controlled Low Strength Materials (CLSM) or Controlled Density Fill (flowable fills) are acceptable backfill materials. Several considerations should be accounted for when using CLSM/CDF backfill. Provisions to prevent flotation of the pipe during placement of the CLSM/CDF must be used. This can include anchoring the pipe by placing flowable fill at the each joint and allowing the fill to partially cure prior to placing the flowable fill along the entire length of the pipe. Also, mechanical anchors such as bent rebar driven into competent soil or precast weights may be used at each joint to prevent flotation. When using CLSM/CDF, the fill should always be placed to completely encase the pipe.
7. Backfill. Backfill from one foot (two feet for HDPE pipe) above the top of the pipe to subgrade elevations shall be structural fill material. Generally, the excavated trench material may be used as this backfill. This backfill shall be placed in 12-inch (12") maximum lifts and compacted to a minimum of 92 percent modified proctor density to prevent excessive settlement at the surface.
8. Vehicular and Construction Loads: Pipe installation shall be suitable to carry H-25 live loads (40,000 lbs. axle - legal load) with 24 inches (24") of cover.

3.9 BACKFILL AGAINST STRUCTURES

- A. Backfilling against masonry or concrete shall only be done when approved. The Contractor shall not place backfill against or on structures until they have attained sufficient strength to support the loads (including construction loads) to which they will be subjected, without distortion, cracking or other damage. As soon as practicable after the structures are structurally adequate and other necessary work has been satisfactorily completed, any leakage tests or other testing of the structures shall be made by the Contractor, as required by the Engineer, at the Contractor's expense.

1. After the satisfactory completion of leakage tests and the satisfactory completion of any other required work in connection with the structures, the backfilling around the structures shall proceed using suitable and approved excavation material. The best of the backfill material shall be used for backfilling within 2 feet (2') of the structure. Just prior to placing backfill, the areas shall be cleaned of all excess construction material and debris and the bottom of excavations shall be in a thoroughly compacted condition.
- B. Symmetrical backfill loading shall be maintained. Special care shall be taken to prevent any wedging action or eccentric loading upon or against the structures.
 1. During backfilling operations, care shall be exercised that the equipment used will not overload the structures in passing over and compacting these fills. Except as otherwise specified or directed, backfill shall be placed in layers not more than 9 inches (9") in loose depth and each layer of backfill shall be compacted thoroughly and evenly using approved types of mechanical equipment. Each pass of the equipment shall cover the entire area of each layer of backfill.
- C. In compacting and other operations, the Contractor shall conduct his operations in a manner to prevent damage to structures due to passage of heavy equipment over and adjacent to structures. Repair damage made by the Contractor, at no additional cost to the Owner.
- D. After backfilling the Contractor shall maintain the surfaces of backfill areas in good condition so as to present a smooth surface at all times level with adjacent surfaces. The Contractor shall repair any subsequent settling over backfilled areas immediately, in a manner satisfactory to the Engineer, and such maintenance shall be provided by the Contractor for the life of this Contract, at no additional cost to the Owner.
- E. The finished subgrade of the filled excavations upon which pavements are to be constructed shall not be disturbed by traffic of other operations and shall be maintained in a satisfactory condition until the finished courses are placed. The storage or stockpiling of materials on finished subgrade will not be permitted.
- F. Uniformly smooth grade all areas to be graded, as indicated including excavated sections and all areas disturbed as a result of the Contractor's operations. The finished surfaces shall be reasonably smooth, compacted and free from surface irregularities.

3.10 COMPACTION

- A. Compaction Requirements [Check with Geotechnical Report]
 1. The degree of compaction is expressed as a percentage of the maximum dry density at optimum moisture content as determined by ASTM D1557, Method C. The compaction requirements are as follows:

Area of Compaction	Minimum Degree
Below footings	95%
Below slabs	95%
Detention basin berms	95%
Pavement base course	95%
Pavement subbase	95%
General fill below pavement subbase	90%
Trench backfill	92%
Lawnareas	90%

2. Compaction percentages are based on the laboratory derived Maximum Density Values.

B. Moisture Control

1. Fill that is too wet for proper compaction shall be harrowed or otherwise dried to a proper moisture content to allow compaction to the required density. If fill cannot be dried within 24 hours of placement, it shall be removed and replaced with drier fill.
2. Fill that is too dry for proper compaction shall receive water uniformly applied over the surface of the loose layer. Sufficient water shall be added to allow compaction to the required density.
3. In no case shall fill be placed over material that is frozen. No fill material shall be placed, spread, or rolled during unfavorable weather conditions. When work is interrupted by heavy rains, fill operations shall not be resumed until the moisture content and the density of the previously placed fill are as specified.

C. Lift Thickness of Material

1. Structural Fill and Sand Borrow. Place in layers not to exceed 9 inches (9") in thickness when utilizing heavy compaction equipment, and 6 inches (6") when utilizing light hand-operated compaction equipment.
2. Common Fill. Place in layers not to exceed 9 inches (9") in thickness when utilizing heavy compaction equipment, and 8 inches (8") when utilizing light hand-operated compaction equipment.
3. Crushed Stone, Gravel, Dense, Graded Crushed Stone for Subbase. Place in layers not to exceed 9 inches (9") in thickness when utilizing heavy compaction equipment, and 6 inches (6") when utilizing light hand-operated compacted equipment. Compact with a minimum of four (4) coverages of acceptable compaction equipment.

3.11 PROTECTION OF FILL

- A. Protection of compacted fill shall be the responsibility of the Contractor. Newly graded areas shall be protected from the actions of the elements and traffic. Any settlement or washing that occurs prior to acceptance of the work shall be repaired and grades shall be established to the required elevations and slopes. Damage to any compacted lift (including those lifts previously tested and approved by the Engineer) occurring at any time during the course of construction, which is caused by equipment, moisture entering the embankment, or from any other cause, shall be fully repaired by the Contractor prior to placement of overlying materials, at no additional cost to Owner and to the complete satisfaction of the Engineer.
- B. In the event of and prior to the commencement of heavy rains, the Contractor shall suspend fill operations immediately and shall take all necessary steps to keep the site as well drained as possible. Fill operations shall not be resumed until the moisture content of the fill is such as to permit compliance with the Specifications.
- C. All corrective work or operations necessary to maintain proper moisture control of the fill material shall be at the expense of the Contractor.

3.12 GRADING TOLERANCES

- A. Grading shall be completed to meet or exceed the following tolerances of uniformity*:

<u>Location</u>	<u>Tolerance</u>
Top of Subgrade Beneath Structures	1/2 inch
Top of Subgrade Beneath Paving	1/2 inch
Top of Subgrade Beneath Landscape Areas	1 inches
Top of Gravel and Gravel Bases	1/4 inch

Uniformity is defined as no variations in the surface materials at the grades and slopes indicated on the Drawings that exceed the listed tolerance over a length of ten feet (10') horizontally in any direction.

END OF SECTION 31 00 00

SECTION 31 10 00

SITE CLEARING

PART 1 - GENERAL

1.1 DESCRIPTION

- A. This Section specifies requirements for site clearing including demolition of site structures.
- B. The work includes:
 - 1. Protection of existing vegetation to remain.
 - 2. Clearing and grubbing.
 - 3. Selective clearing and thinning.
 - 4. Site demolition of structures, retaining walls, signage, light standards, foundations and appurtenances.
 - 5. Removal and abandonment of utilities.
 - 6. Filling or removal of underground tanks and piping.
 - 7. Disposal of material from clearing, grubbing, thinning and demolition in approved off-site disposal areas.
 - 8. Filling of voids and excavations resulting from the work.

1.2 RELATED SECTIONS

- A. Other Specification Sections which directly relate to the work of this Section include:
 - 1. Section 31 25 00 - EROSION AND SEDIMENTATION CONTROLS.
 - 2. Section 31 00 00 - EARTHWORK.

1.3 SITE CONDITIONS

- A. Sitework has been performed on and in the immediate vicinity of the project site since project survey in association with other projects by the owner. Specific reference is made to plans titled 'Advance Utility Site Plans for Roger Williams Park Zoo Education Center & Pavilion', dated December 16, 2023, and those plans are made a part hereof, as if attached hereto. The contractor shall familiarize themselves with the conditions at the site and the extent of additional work anticipated to be performed by others on those plans, and shall perform all work necessary to coordinate for the completion of work shown on the plans at no additional expense to the Owner.
- B. Site conditions existing during the bidding period will be maintained by the Owner insofar as practical.
- C. Actual site condition variations that differ from those of the bidding period and which affect site clearing operations shall be brought to the attention of the Owner prior to the commencement of any site work.

1.4 SUBMITTALS

- A. The Contractor shall submit the following information to the Engineer for review before commencing work:
 - 1. All permits and notices authorizing site clearing and demolition.
 - 2. Certificates of utility service severances.
 - 3. Permits for transport and disposal of debris.
 - 4. Demolition procedures and operational sequence.

PART 2 - PRODUCTS

21 TREE PROTECTION FENCING

- A. Tree protection fencing shall be 6' high snow fence. Posts shall be 8' standard steel posts driven a minimum of two (2) feet into the ground.

PART 3 - EXECUTION

3.1 PROTECTION

- A. The Contractor shall flag the limits of clearing shown on the drawings by accurate field survey with marked stakes or other means acceptable to the Engineer. Trees to remain and trees to be saved and transplanted shall be clearly identified during this staking process. The Engineer shall be notified a minimum of five (5) working days prior to scheduled commencement of clearing operations to review the flagged limits. Adjust the clearing limits as directed by the Engineer.
- B. Before clearing begins, protect designated trees to remain with tree protection fencing to the approximate diameter of foliage (dripline of the tree) to prevent damage to the trunk, foliage and root system by construction equipment and procedures. Trees to be transplanted may be removed to another location, or may be left in place and be protected in similar fashion as the trees to remain as described above.
- C. Place tree protection fencing as required to protect other plants, adjacent property areas to remain uncleared, monuments, and existing improvements from damage.
- D. The Contractor shall repair or replace immediately any damage to existing trees or root systems that are to remain and to trees that are to be transplanted. The Contractor shall employ an arborist licensed in the jurisdiction of the Project State of Rhode Island to determine the repair and replacement needs and methods for approval by the Engineer.
- E. Replace damaged shrubs and other vegetation designated to remain with the same size and species.
- F. The tree protection fencing shall be maintained for the duration of construction operations. The work shall include immediate replacement of any damaged fence. Fencing shall be removed from the site at the completion of construction operations. The fencing disposal shall be in accordance with local, state, and federal laws and regulations for the disposal of the material.

3.2 UTILITIES

- A. Notify all corporations, companies, individuals, or local authorities owning or having jurisdiction over utilities running to, through, or across areas to be affected by site clearing operations.
- B. Locate and identify existing utilities that are to remain and protect them from damage.
- C. For utilities to be disconnected, have utility services disconnected in accordance with the requirements of the utility owner.

3.3 CLEARING AND GRUBBING

- A. Clearing shall include cutting, removal, and off-site disposal of trees, bushes, shrubs, stumps, fallen timber, brush, refuse, trash, fencing and other incidental materials not required for reuse on the site.
- B. The Contractor shall grub the area within the clearing limits to completely remove stumps and root systems, except for those to remain or those to be transplanted.
- C. Depressions, excavations and voids resulting from the removal of stumps or roots shall be filled with suitable material and compacted as specified under Section 31 00 00 — EARTHWORK.

3.4 SELECTIVE CLEARING AND THINNING

- A. Selective clearing and thinning shall be completed as directed by the Engineer. Approximate limits of selective clearing and thinning are shown on the Drawings.
- B. The work shall include the removal of dead and diseased tree limbs and plants, and pruning and removal of live vegetation that interferes with the growth of other trees and plants. Areas of dense growth shall be thinned to provide room for healthy growth.

3.5 DEMOLITION REQUIREMENTS

- A. A. Conduct demolition operations in a manner that will prevent damage to adjacent structures, utilities, pavements, and other facilities to remain.
- B. Cease operations immediately if any damage, settlement or other adverse effect on adjacent structures occurs. However, if an obvious unsafe condition is created that would potentially cause injury to persons or undue harm to properties, the Contractor shall take whatever measures are warranted to prevent such injury or harm. Immediately notify the Engineer and regulatory authorities. Do not resume operations until conditions are corrected, damage repaired and approval has been received from the appropriate authorities and the Owner's Representative.
- C. Obtain written permission from adjacent property owners when demolition equipment will traverse, infringe upon, or affect access to their property. Copies of the permission documents shall be submitted to the Engineer.

- D. Provide hoses and water connections. Spray water on demolition debris to minimize dust.
- E. Clean adjacent structures and improvements of dust, dirt, and debris caused by demolition operations. Return adjacent areas to condition which existed prior to start of work.
- F. All hazardous waste removal shall be performed by a hazardous waste contractor qualified and duly licensed in the jurisdiction of the Project [State of Rhode Island] to remove, transport, and dispose of each type of hazardous substance.
- G. Comply with federal, state, and local regulations pertaining to the crushing, processing, and reuse of Asphalt Pavement, Brick and Concrete Rubble.

3.6 DEMOLITION

- A. Demolish buildings completely and remove from site, or remove intact, in accordance with the approved permits, procedures and operational sequence.
- B. Locate demolition equipment and remove materials in a manner that prevents excessive loading to supporting walls, floors, or framing.
- C. Remove all debris and other materials from basement areas.

3.7 FILLING BASEMENT AND VOIDS

- A. Completely fill all voids including, but not limited to: basement areas, excavation areas, and voids resulting from demolition or removal of structures including underground fuel storage tanks, wells, and cisterns with suitable material as specified in Section 31 00 00 EARTHWORK.
- B. Areas to be filled shall be free of standing water, frost, frozen, and unsuitable material prior to fill placement.
- C. Place and compact fill materials in conformance with the requirements of Section 31 00 00 — EARTHWORK.
- D. Grade surface of filled areas to match adjacent grades and slope to provide surface drainage.

3.8 REMOVAL AND ABANDONMENT OF UTILITIES

- A. All existing structures, utilities, and appurtenances of any kind shall be completely removed within the limits of excavation for the new buildings and for a distance of 10 feet beyond. Remove all utilities beneath exterior columns and for a distance of 10 feet beyond.
- B. Outside the limits of excavation for the new buildings, all abandoned utilities and utility structures greater than 8 inches in diameter located at least 4 feet below bottom of finished grade shall be sealed with concrete or brick masonry at the limit of excavation. All utilities shall be entirely removed within 4 feet of finished grade.

- C. Manholes and catch basins designated to be abandoned shall have all lines plugged with brick and mortar prior to filling with sand or gravel. The top 4 feet of these structures shall be removed and the bottom slab broken up to permit drainage prior to filling.
- D. The Contractor shall remove frames, covers, and grates from manholes, catch basins and gate valves and satisfactorily store and protect them until they are required for reuse in the work. Existing frames, covers, and grates determined by the Engineer to be unsuitable for reuse shall be removed from the site.

3.9 DISPOSAL OF DEMOLISHED MATERIALS

- A. Remove from site all materials resulting from site clearing and demolition operations.
- B. No burning of any material will be allowed.

END OF SECTION 31 10 00

THIS PAGE INTENTIONALLY LEFT BLANK

SECTION 31 23 19

DEWATERING

PART 1 - GENERAL

1.1 DESCRIPTION

- A. This Section specifies the dewatering requirements for control of surface and subsurface water within the site.
- B. The work includes:
 - 1. Control of surface water runoff to prevent flooding of excavations, trenches, and adjacent properties, and the saturation and loosening of soils.
 - 2. Removal of subsurface water from excavations and trenches.
 - 3. Provision of equipment and facilities to remove sediment and control the rates and volumes of disposal of surface and subsurface waters removed from the work areas.
 - 4. Provisions for the protection of adjacent and downgradient properties and environmental resources.

1.2 RELATED SECTIONS

- A. Sections which directly relate to the work of this Section include:
 - 1. Section 31 10 00 - SITE CLEARING.
 - 2. Section 31 25 00 - EROSION AND SEDIMENTATION CONTROLS.
 - 3. Section 31 00 00 - EARTHWORK (SITE).
 - 4. Section 33 39 00 - SANITARY UTILITY SEWERAGE STRUCTURES.
 - 5. Section 33 40 00 - STORM DRAINAGE UTILITIES.

1.3 DEWATERING SYSTEM REQUIREMENTS

- A. The Contractor shall design the dewatering systems to:
 - 1. Effectively reduce the hydrostatic pressure and lower the groundwater levels to a minimum of 2 feet below the bottom of excavations;
 - 2. Develop a substantially dry and stable subgrade for the proposed work;
 - 3. Prevent damage to adjacent properties, buildings, structures, utilities and other facilities;
 - 4. Ensure that, after 12 hours of initial pumping, no soil particles will be present in the discharge;
 - 5. Retain all sediments on-site within the work area.

- B. Locate dewatering facilities where they will not interfere with utilities and construction work to be done by others.
- C. Modify dewatering equipment and procedures when operations threaten to cause damage to new or existing facilities or adjacent areas not within the Limits of Work.

1.4 SUBMITTALS

- A. Prior to installation of the dewatering system, submit working drawings and design data prepared by a registered professional engineer licensed in the jurisdiction of the Project, with the following information:
 - 1. The proposed types of dewatering systems;
 - 2. Arrangement, location and depths of system components;
 - 3. Complete description of equipment and instrumentation to be used including installation, operation, and maintenance procedures;
 - 4. Types and sizes of filters;
 - 5. Design calculations demonstrating adequacy of the proposed system and equipment;
 - 6. Provisions and methods of sediment removal and disposal of water; and
 - 7. All permits required for the work.
- B. Submit records required in Article 3.03.

PART 2 - PRODUCTS

(Not Applicable)

PART 3 - EXECUTION

3.1 SURFACE WATER CONTROL

- A. Intercept and divert surface water runoff away from excavations through the use of dikes, curbing, walls, ditches, pipes, sumps or other approved means.
- B. Provide and maintain ditches of adequate size to collect and prevent surface and subsurface water seepage from entering the excavations. Divert the water to settling basins or other approved equipment required to reduce the amount of fine particles before discharge into drainage pipes and natural water courses. If a drainage system or water course is silted or becomes blocked due to dewatering operation, it shall be cleaned by the Contractor at no additional cost to the Owner. Any enforcement actions or fines resulting from improper dewatering and/or discharge of turbid water and sediment to protected areas shall be the sole responsibility of the Contractor.

3.2 DEWATERING EXCAVATIONS

- A. Perform dewatering operations to lower the groundwater level in excavations as required to provide a stable, dry subgrade for the prosecution of the proposed work.
- B. Maintain dewatering operations in a manner that prevents buildup of excessive hydrostatic

pressure and damage to structures and the subgrade.

- C. Do not allow water to accumulate in excavations. Contractor shall provide and maintain ample means and devices to remove promptly, and to dispose of properly, all water entering excavations and to keep them dry until the proposed work is completed.
- D. Do not discharge water to protected environmental resources without treatment to remove suspended solids and sediments.
- E. No pipe shall be laid in water. No masonry shall be laid in water, and no water shall be allowed to inundate new concrete and new brick masonry within 48 hours after installation. Contractor shall constantly guard against the possibility of flotation of pipe or structures after installation. Backfill or other means shall be placed promptly to prevent this occurrence.

3.3 RECORDS FOR WELL SYSTEMS

- A. When well point or other type of well systems are used for dewatering, the following information shall be obtained and recorded:
 - 1. The average flow rate and time of operation of each pump used in the dewatering system. Provide appropriate devices, such as flow meters, for observing the flow rates. Submit the data, in tabular form, during the period that the dewatering system is in operation.
 - 2. The groundwater elevations during the period that the dewatering system is in operation. Submit observation records daily within 24 hours of reading. During the initial period of the dewatering, make required observations on a daily basis. If, after a specified period, dewatering operations have stabilized, observations may be changed to longer intervals as accepted by the Engineer.

END OF SECTION 31 23 19

THIS PAGE INTENTIONALLY LEFT BLANK

SECTION 31 25 00

EROSION AND SEDIMENTATION CONTROLS

PART 1 - GENERAL

1.1 DESCRIPTION

- A. This Section specifies requirements for temporary and permanent erosion and sedimentation control provisions as they relate to the construction process.
- B. All work specified in this Section shall be performed in accordance with 'Soil Erosion and Sediment Control Plan, Roger Williams Park Zoo Education Center & Pavilion, 1000 Elmwood Avenue, Providence, Rhode Island, Assessor's Plat 90, Lot 157, dated January 25, 2023, prepared by Garofalo & Associates, Inc.
- C. The work includes:
 - 1. Providing and maintaining all temporary erosion and sedimentation control measures shown on the Drawings and required by the Engineer during the life of the Contract to control soil erosion and water pollution
 - 2. The installation and maintenance of additional silt fence, berms, ditches, sedimentation basins, construction exits, fiber mats, catch basin filters, straw, netting, gravel, trenches, mulches, grasses, and other approved erosion control devices or methods, needed to protect any areas on or off site in accordance with the Soil Erosion and Sediment Control Plan (SESC) to be developed by the Contractor which is required by the EPA or its' locally designated agency.

1.2 RELATED SECTIONS

- A. Sections which directly relate to the work of this Section include:
 - 1. Section 31 10 00 — SITE CLEARING.
 - 2. Section 31 00 00 — EARTHWORK

1.3 DEFINITION AND COORDINATION OF EROSION AND SEDIMENTATION CONTROL PROVISIONS COORDINATION

- A. Permanent erosion and sedimentation control measures are defined as those elements that are to be incorporated into the final project product, including but not necessarily limited to such items as: finish paving and landscape, forebays, sedimentation control structures (catch basins, etc.), swales, berms, and other such items.

- B. Temporary erosion and sedimentation control measures are defined as those elements that are required by permit approvals and necessary to be installed by the Contractor to meet federal, state and local regulations for the construction program, including, but not necessarily limited to, such items as: silt sock, portable sedimentation basins, inlet protection, and other such items, all of which shall be removed by the Contractor after installation of permanent erosion and sedimentation control measures, stabilization of the site, and prior to final completion of the project.
- C. The temporary control provisions shall be coordinated with the permanent erosion and sedimentation control features to the extent practical to ensure economical, effective, and continuous erosion and sedimentation controls throughout the construction and post-construction periods.

1.4 LAWS AND REGULATIONS

- A. RIDEM Wetlands Permit No. 23-0026, RIPDES Permit No. RIR 102490 and Groundwater Discharge/UIC Permit No. 002169 are hereby incorporated into these specifications. Contractor shall prepare and post signs as required by RIDEM
- B. Compliance with the RIPDES Stormwater Regulations is the responsibility of the Contractor.

1.5 PRIOR TO CONSTRUCTION

- A. Prior to the start of the construction, the Contractor shall submit to the Engineer the following: schedules for the construction of required stormwater detention basins, temporary and permanent erosion and sediment control work, clearing and grubbing, grading, structures at watercourses, construction, and paving. No work shall be started until control schedules and methods of operations have been submitted to the Engineer.
- B. Proof of submittal and receipt of an acknowledgement of the Notice of Intent (NOI) for an RIPDES General Permit for Construction Activities as further outlined under this Section, Section 31 25 00 — EROSION AND SEDIMENTATION CONTROLS.

1.6 CONSTRUCTION OPERATIONS

- A. When in the opinion of the Engineer it becomes necessary, the Engineer will inform the Contractor of construction procedures and operations that jeopardize erosion and sedimentation control provisions. If these construction procedures and operations are not corrected promptly, the Owner may suspend the performance of any or all construction until corrections have been made, and such suspension shall not be the basis of any claim by the Contractor for additional compensation from the Owner nor for an extension of time to complete the Work.

PART 2 - PRODUCTS

2.1 MATERIALS

- A. Temporary erosion control seed for quick growing grasses such as wheat, rye or oats shall be planted only when permanent grasses cannot be planted due to the growing season. All permanent grass areas planted with temporary erosion control seed shall be replaced with permanent seed.

<u>Seed</u>	<u>Percent by Weight</u>	<u>Percent Germination Minimum</u>
Winter Rye	100 (Min)	85
Red Fescue (Creeping)	4 (Min)	80
Perennial Rye Grass	3 (Min)	90
Red Clover	3 (Min)	90
Other Crop Grass	0.5 (Max)	
Noxious Weed Seed	0.5 (Max)	
Inert Matter	1.0 (Max)	

- B. Erosion Control Blanket/Fabric Netting

- 1. Curlex blankets, as manufactured by American Excelsior Company.

- C. Filter fabric at construction entrance shall be 600X, as manufactured by Mirafi.

- D. Silt Sacks and Sediment Control Devices.

- 1. Silt sacks shall be a woven polypropylene geotextile fabric with strength per ASTM D4884 manufactured to fit the opening of the catch basin. Silt sacks shall be Siltsack @ as manufactured by ACF Environmental, Inc., or approved equal.
 - 2. Silt sacks shall be manufactured with a high flow bypass weir for large inflow events. Field modification, including cutting or puncturing of the fabric, will not be allowed.
 - 3. Install at locations indicated on the Drawings.

- E. Siltsack / Sediment Wattle / Filter Sock filled with compost as manufactured by Filtrexx International, LLC.

PART 3 - EXECUTION

3.1 EROSION CONTROL BLANKET

- A. Erosion control mats shall be installed in accordance with the manufacturer's recommendations.
- B. Areas to receive mats shall be smooth graded and compacted. Remove all rocks, dirt clods, vegetation, and other obstructions that may cause damage to the mats.

- C. Unroll mats parallel to the direction of water flow and lay flat against the ground. Overlap roll ends a minimum of 1 foot with upslope mat on the top to prevent uplift of mat end by water flow. Overlay adjacent edges of mat by six (6) inches. Extend mat a minimum of 2 feet above the crest of steep slopes and anchor by excavating a 6-inch-deep trench, and secure end of mat in trench using staples or pins furnished by manufacturer of mat. After securing mat end in place, backfill and compact trench.

3.2 SEDIMENT WATTLE / FILTER SOCK

- A. Shall be installed at the locations, shown on the Drawings and in general as follows:
 - 1. Toe of slope of embankment construction to filter all runoff flowing to off-site discharges.
 - 2. Toe of temporary earthwork stockpile slopes.
 - 3. Across construction ditches prior to entry into drainage system or waterway, and at 50-foot intervals along the remainder of the ditch.
 - 4. Surrounding completed drainage inlets.
 - 5. Other locations shown on the Contract Drawings and required by laws, regulations, and permits

3.3 CONSTRUCTION REQUIREMENTS — TEMPORARY EROSION AND SEDIMENTATION CONTROL

- A. The Contractor shall construct all permanent erosion and sedimentation control features at the earliest practical time as outlined in the accepted schedule. Temporary erosion and sedimentation control measures shall be used to correct conditions that develop during construction which were unforeseen, but are needed prior to installation of permanent erosion and sedimentation control features, or that are needed temporarily to control erosion or sedimentation which develops during construction operations.
- B. Where erosion is likely to be a problem, clearing and grubbing operations shall be scheduled and performed so that grading operations and permanent erosion and sedimentation control features can follow immediately thereafter, if conditions permit; otherwise, temporary erosion and sedimentation control measures will be required between successive construction stages.
- C. Contractor shall be responsible for controlling erosion within the project area and retaining sediment on-site away from sensitive environmental resources. Any fines, construction delays, remedial actions, or incarceration resulting from the Contractor's failure to comply with these provisions shall be the responsibility of the Contractor and not the Owner.
- D. Failure by the Contractor to control erosion, pollution, and siltation shall be cause for the Owner to employ outside assistance to provide the necessary corrective measures. The cost of such assistance, including engineering costs, will be charged to the Contractor and appropriate deductions made from the Contractor's monthly progress payment.
- E. The Contractor shall remove and properly dispose of sediment from control facilities as required by the Engineer. The Contractor shall modify and improve erosion and sedimentation control facilities and replace deteriorated straw bales and other devices as required by the Engineer.

- F. Minimum temporary and permanent erosion and sedimentation control measures are shown on the Drawings. The Contractor shall strictly adhere to the minimum provisions shown. Additionally, temporary measures shall be selected and constructed by the Contractor in consultation with the Engineer to accommodate changing field conditions that develop during construction.
- G. The temporary sedimentation basins shall be maintained from the start of construction until construction of the permanent detention basins and/or stormwater system is completed and perimeter areas are stabilized. A temporary outlet shall be constructed above the expected sediment levels. Construction of the basins shall be sequenced so that the temporary outlet is installed and basin embankment is constructed with the material available from the initial site excavations.
- H. Per RIPDES Permit requirements, in disturbed areas where construction has permanently or temporarily ceased, the area must be stabilized within 14 days. If earth-disturbing activities will resume within 14 days, temporary stabilization is not required.
- I. All disturbed areas shall be re-vegetated by foaming and seeding unless otherwise noted on the approved plan.

3.4 MAINTENANCE OF EROSION AND SEDIMENTATION CONTROL MEASURES

- A. The Contractor shall check the condition of erosion and sedimentation control devices daily and maintain them in good operating condition. Silt sock shall be replaced when deteriorated.
- B. The Contractor shall inspect the condition of ditches, sediment traps, and other erosion and sedimentation control devices after each rainstorm and during major storm events. Repairs shall be made as necessary.
- C. During construction, temporary outlets of the drainage systems shall direct the flow to temporary or permanent sedimentation basins.
- D. Temporary soil erosion and sedimentation control devices shall be removed and adjacent areas outside the limits of grading restored upon completion of the work or when required by the Engineer.

END OF SECTION 31 25 00

THIS PAGE INTENTIONALLY LEFT BLANK

SECTION 32 12 15

ASPHALT PAVING

PART 1 - GENERAL

1.1 **DESCRIPTION**

- A. Work under this section consists of furnishing hot mix asphalt (HMA) pavement (On the drawings, this is also referred to as “bituminous concrete pavement”.) composed of mineral aggregate, reclaimed asphalt pavement (RAP), asphalt binder material and an anti-strip additive (if required), that are mixed in a central mixing plant and then placing the mix on a prepared course in accordance with these specifications and conformance to the lines, grades, thicknesses and typical cross sections as shown on the plans or as directed by the Owner.
- B. The work includes:
1. Preparation for HMA paving and furnishing and installing HMA.
 2. HMA overlays over existing pavement, including surface preparation, and leveling courses, tack coating and all other associated operations required.
 3. Sawcutting existing pavements.
- C. Acceptance of plant produced material for gradation, asphalt content, and air voids shall be determined by the owner in accordance with the requirements of Article 3.09 ACCEPTANCE CRITERIA.

1.2 **RELATED SECTIONS**

- A. Sections which directly relate to the Work of this Section include:
1. Section 31 00 00 - Earthwork
 2. Section 32 16 10 – Curbing
 3. Section 32 17 23 – Pavement Markings

1.3 **REFERENCE STANDARDS**

- A. References herein are made in accordance with the listed specific standards of the following organization and Work under this Section shall conform to the latest edition, unless modified by these specifications.
- AASHTO — American Association of State Highway and Transportation Officials
ASTM — American Society for Testing and Materials
AI — Asphalt Institute
FHWA — Federal Highway Administration
RIDOT - Rhode Island Department of Transportation, Standard Specifications for Road and Bridge Construction
NETTCP — New England Transportation Technician Certification Program

1.4 WEATHER LIMITATIONS

- A. Construct pavement when atmospheric temperature is above 40°F, the base is not frozen, and there is not any film (free standing) of water on the base to be paved.
- B. The required temperature of the HMA mixture, within a tolerance of plus or minus 15°F, when delivered at the site, will be governed by the temperature of the base upon which the mix is placed, as follows:

TABLE 1

Base Temperature in Degrees F	Required Material Temperature in Degrees F For Course Thickness in Inches			
	1	1-1/2	2	3 and Greater
35-40	-	305	295	280
41-50	310	300	285	275
51-60	300	295	280	270
61-70	290	285	275	265
71-80	285	280	270	265
81-90	275	270	265	260
91 & over	270	265	260	255

- C. Tack coat shall be applied only when the ambient temperature is above 40°F, and when the temperature has been above 35°F for 12 hours immediately prior to application. Do not apply when base is wet, contains excess moisture, or during rain.

1.5 SUBMITTALS

- A. Job Mix Formula (JMF): No HMA shall be produced until a JMF has been submitted by the Contractor and reviewed by the Owner’s representative. The HMA shall be designed using procedures contained in Chapter 5, MARSHALL METHOD OF MIX DESIGN, of the Asphalt Institute’s (AI) Manual Series No. 2 (MS-2), Mix Design Methods for Asphalt Concrete, and shall meet the requirements of Table 3 and Table 4.
- B. JMF Submittal: The job mix formula shall be submitted in writing by the Contractor at least 30 days prior to the start of paving operations and shall include as a minimum:
 1. Percent passing each sieve size.
 2. Gradation and percent of each individual aggregate or mineral filler, including source, location, and bulk specific gravity.
 3. Percent of asphalt binder.

4. Performance graded asphalt binder certified test results and Material Certificate certifying the PG grade, including source and location.
 5. Number of blows of hammer compaction per side of Marshall molded specimen.
 6. Mixing temperature.
 7. Compaction temperature.
 8. Temperature of mix when discharged from the mixer.
 9. Plot of the combined gradation on the Federal Highway Administration (FHWA) 0.45 power gradation curve.
 10. Graphical plots of stability, flow, air voids, voids in the mineral aggregate, and unit weight verses asphalt content.
 11. Percent natural sand.
 12. Percent fractured faces.
 13. Percent elongated particles.
 14. Tensile Strength Ratio (TSR)
 15. Antistrip agent – type, quantity, supplier and location.
- C. Performance Graded Asphalt Binder Material: The certification(s) shall show the appropriate AASHTO and/or ASTM test(s) for each material, the test results, and a statement that the material meets the specification requirement.
Reference AASHTO MP-1 and PP6
1. Flash point
 2. Rotational viscosity at 135°C and 165°C
 3. Specific gravity at 25°C
 4. Original $G^*/\sin\delta$ and phase angle at test temperature
 5. RTFO percent mass loss (rolling thin film oven)
 6. RTFO - $G^*/\sin\delta$ and phase angle at test temperature
 7. PAV Residue - $G^*(\sin\delta)$ and phase angle at test temperature
 8. Creep stiffness and m-value at test temperature
 9. Direct tension results (when equipment available)
 10. Strain sweep in accordance with AASHTO TP-5 (optional)
 11. Physical hardening after 24 hours in accordance with AASHTO TP-1 (optional)
 12. Mixing and Compaction viscosity-temperature chart

- D. Asphalt Anti-Stripping Additive: This specification provides for an additive to asphalt to assist in the coating of wet aggregate and to increase the resistance of the asphalt binder coating to stripping in the presence of water. The additive shall be chemically inert to asphalt (heat stable) and when blended with asphalt shall withstand storage at a temperature of 400°F for extended periods without loss of effectiveness.
- E. Testing Laboratory: The laboratory used to develop the JMF shall meet the requirements of ASTM D 3666. A certification signed by the manager of the laboratory stating that it meets these requirements shall be submitted with the JMF.
- F. Certified Test Reports: Submit Certified Test Report(s) signed by the material producer and Contractor certifying that materials comply with, or exceed, the requirements herein. Owner reserves the right to employ an independent testing laboratory for testing materials included in the JMF, and Contractor shall, upon request of Owner, supply suitable quantities of these materials for such testing.

1.6 COORDINATION

- A. The Contractor shall coordinate paving with all other work, especially underground utility construction, to prevent covering up unfinished or uninspected work and loss of time or labor by improper scheduling. Any repaving required shall be done at no cost to Owner.

PART 2 PRODUCTS

2.1 MATERIALS

- A. Aggregate: Aggregate shall consist of crushed stone, with or without sand or other inert finely divided mineral aggregate. The portion of the materials retained on the #4 sieve (4.75 mm) shall be known as coarse aggregate, the portion passing the #4 sieve (4.75 mm) and being retained by the #200 sieve (0.075 μm) as fine aggregate, and the portion passing the #200 sieve (0.075 μm) as mineral filler.

1. Coarse Aggregate

- a. Coarse aggregate shall consist of sound, tough, durable particles, free from adherent coatings of clay, organic matter, and other deleterious substances. It shall show no more wear than forty (40) percent loss when used in Surface or Friction Courses and no more than fifty (50) percent loss when used in HMA base and binder courses, when tested in accordance with AASHTO - T96, nor shall the sodium sulfate soundness loss exceed twelve (12) percent, after five cycles, when tested in accordance with AASHTO T104.
- b. The coarse aggregate shall not contain more than ten (10) percent, by weight, of flat or elongated pieces, when tested in accordance with ASTM D4791 at a ratio stated within the standard specifications, or in lieu of, 3:1. A flat particle is one having a ratio of width to thickness greater than the

stated ratio; an elongated particle one having a ratio of length to width greater than the stated ratio. An aggregate particle whose maximum length is the stated ratio times its maximum thickness is considered flat and elongated.

2. Fine Aggregate

- a. Fine aggregate shall consist of sand, or clean, sound, durable, angular particles produced by crushing natural stone, or gravel that meets the requirements for wear and soundness specified for the coarse aggregate. The aggregate particles shall be free from coatings of clay, silt, or other objectionable matter and shall contain no clay balls. The fine aggregate, including any blended material for the fine aggregate, shall have a plasticity index of not more than 4 and a liquid limit of not more than 25 when tested in accordance with AASHTO T89 and AASHTO T90.

The fine aggregate, when subjected to five (5) cycles of the soundness test according to AASHTO T104, shall have a loss of not more than fifteen (15) percent when tested with sodium sulfate.

- b. Fine aggregates shall have sand equivalent values of 40 or greater when tested in accordance with AASHTO T176. The sand equivalent value shall be determined for the combined mix aggregates, including coarse and fine aggregates and mineral filler portions.
- c. In the fine aggregate sieve analysis passing #4 (4.75mm), the amount between two successive sieves #16, #30, #50, and #100 shall not exceed 33% of the fine aggregate total.
- d. The fine aggregate, as delivered to the mixer, shall meet the following gradation requirement:

TABLE 2

Sieve	Percent Passing	
	Minimum	Maximum
3/8 inch	95	100
No. 8	70	95
No. 50	20	40
No. 200	2	16

- 3. Mineral Filler: If filler, in addition to that naturally present in the aggregate, is necessary, it shall meet the requirements of AASHTO M17.

- B. Recycled Asphalt Pavement (RAP): The use of a maximum of 10 % recycled asphalt pavement (RAP) will be allowed in the HMA surface courses. All other HMA mixtures may contain a maximum of 25% RAP by mass of the entire mixture.

1. The RAP, incorporated into the HMA mixtures, shall be maintained as a separate captive stockpile and shall not be added to without prior approval. RAP shall consist of asphalt pavement recovered by cold milling or other removal techniques. The RAP shall be crushed so that 100 percent passes the 3/4-inch sieve, or a smaller size depending on the mixture being produced. The Contractor shall assure that the RAP is free from contaminating substances such as joint seal compound.
 2. The coarse aggregate in the RAP shall be crushed stone and the top-size shall not exceed the maximum aggregate size established by the JMF. The final HMA mixture containing RAP shall conform to all the specification requirements contained herein.
 3. For mixtures containing 15% or less RAP, the asphalt binder shall be a PG 64-28. For mixtures containing greater than 15% and up to 25% RAP, the asphalt binder grade shall be a PG 58-34.
 4. For design purposes, the specific gravity of the combined aggregate blend with RAP used in a HMA mixture shall be determined in accordance with the attached test method for BULK SPECIFIC GRAVITY OF AGGREGATE BLENDS WITH RAP.
- C. Asphalt Binder Material: The types, grades, controlling specifications, and maximum mixing temperatures for the asphalt binder materials shall conform to the following:

THE PGAB GRADE SELECTED FOR THIS CONTRACT IS PG 64-28 and PG 58-34 as applicable. If traffic speed and/or level warrant, the PGAB may be adjusted by the Owner for the Design Traffic conditions in accordance with Table below:

SUPERPAVE PGAB Adjustment for Design Traffic Conditions

Traffic Loading

Adjustment to PGAB Grade

Standing
(<20 km/h)

Increase high temperature grade by 2 grades (12° C).
Use low temperature grade as determined by LTTT BIND software.

Slow Transient
(20 to 70 km/h)

Increase high temperature grade by 1 grade (6° C).
Use low temperature grade as determined by LTTT BIND software.

Traffic Level (ESALs)

Adjustment to PGAB Grade

1×10^7 to 3×10^7

Consideration should be given to increasing high temperature grade by 1 grade (6°C). Use low temperature grad as determined by LTPP BIND software

$>3 \times 10^7$

Increase high temperature grade by 1 grade (6°C). Use low temperature grade as determined by LTPP BIND software.

The blending at the HMA plants of PG binder from different suppliers is strictly prohibited. Contractors may switch to another approved source of PG binder, upon written notification to the Owner, and by certifying that the tank to be utilized has been drained to an un-pumpable condition. The tank shall not retain more than 0.5% in volume capacity of previous residue source. Contractors who blend PG binders will be reclassified as a supplier and required to certify the binder in accordance with AASHTO MP1 and AASHTO PP-26. Also if any modifications, blending, or addition of additives occurs, the Contractor shall re-certify the material in accordance with AASHTO MP1 and AASHTO PP-26.

- D. Tack Coat: Emulsified asphalt; AASHTO M140/ASTM D 997 or AASHTO M 208/ASTM D 2397, SS-1, SS-1h, RS-1 or CRS-1, CSS-1 or CSS-1h..
- E. Mineral Filler: Rock or slag dust, Portland cement, or other inert material complying with AASHTO M 17/ASTM D 242.
- F. Anti-stripping additive: Shall be incorporated and thoroughly dispersed in the asphalt binder material in an amount equal to the percent by weight established by the job mix formula. This percent is based on the efficiency of the additive as determined by laboratory tests. The treated composite mixture shall have a minimum tensile strength ratio (TSR) of not less than 75, when tested in accordance with AASHTO T283 with the freeze/thaw cycle. The specimens for the AASHTO procedure shall be 4" (100mm) in diameter, compacted with the Marshall hammer or the Superpave gyratory compactor to the desired air void level of $7.0 \pm 1.0\%$. If the TSR ratio is less than 75, the aggregates shall be treated with an approved antistrip in sufficient quantity to produce acceptable results. The hot mix asphalt materials and asphalt binder material that require antistrip additives (either liquid or mineral) shall continue to meet all requirements specified herein for binder and HMA. The anti-strip agent shall be included in the bid price.
- G. Hot Mix Asphalt: Plant mix may be composed of a homogeneous mixture of aggregate, filler if required, asphalt binder, and/or additives, combined to meet the composition limits by weight and other characteristics as specified. The several aggregate fractions shall be sized, uniformly graded and combined in such proportions that the resulting mixture meets the grading requirements of the following specifications:

TABLE 3 SIEVE ANALYSIS OF MIX

Sieve	PERCENT BY WEIGHT PASSING			
	Intermediate Binder Course	Heavy Duty Top	Top Course	Curbing/ Leveling Course
2 inch				
1 inch	100			
3/4 inch	90-100	100		
1/2 inch		80-100	100	100
3/8 inch	40-65	70-90	95-100	90-100
No. 4		50-70	55-75	80-100
No. 8	25-40	35-50	40-65	60-82
No. 16				
No. 30		18-29	20-30	35-55
No. 50	8-17	13-23	10-20	22-38
No. 100				10-22
No. 200	2-6	3-8	3-8	5-12
PGAB (%)	4.0-6.0	5.0-7.0	6.0— 7.5	7.0—10.0
Temp. Mix (°F)	265—325	265-325	265— 325	265—325
Marshall Blows	50	75	50	50
Stability, lbs. (min.)	1000	1500	1000	1000
Flow, hundredths of an inch	8—16	8-16	8—16	8—16
Percent Air Voids	3.0—8.0	3.0-5.0	3.0— 5.0	3.0—5.0

1. The mineral aggregate shall be of such size that the percentage composition by weight, as determined by laboratory sieves, will conform to the gradation or gradations specified in Table 3 when tested in accordance with AASHTO Standards T27 and T11.
2. The gradations in Table 3 represent the limits, which shall determine the suitability of aggregate for use from the sources of supply. The aggregate, as selected (and used in the JMF) and blended, shall have a gradation within the limits designated in Table 3 and shall not vary from the low limit on one sieve to the high limit on the adjacent sieve, or vice versa, but shall be well graded from coarse to fine.
3. Deviations from the final approved mix design for gradation of aggregates shall be within the tolerances for individual measurements as specified in these

requirements. The job mix formula tolerances will apply if they fall outside the grading band in Table 3. All mixture furnished for the work shall conform to the job mix formula within the tolerance ranges as specified.

4. The asphalt binder content (PGAB percentage) shall meet the minimum requirements stated in Table 3 for each mixture type. The asphalt binder content of the mixture shall be calculated on the percentage basis by weight of the total mix.
5. The maximum size aggregate used shall not be more than one-half of the thickness of the compacted course being constructed on a prepared surface or that which can be placed to achieve specification requirements. The maximum size is defined as one sieve size larger than the nominal maximum size. The nominal maximum size is defined as one sieve size larger than the first sieve to cumulatively retain more than 10 percent.

H. Additional Criteria

1. In addition to the above Marshall requirements, the mixtures shall also conform to the following:

TABLE 4

MINIMUM PERCENT VOIDS IN MINERAL AGGREGATE

U.S.A. Standard Sieve Designation Inches	Nominal Maximum Particle Size		Minimum Voids in Mineral Aggregate Percent
	<u>Inches</u>	<u>mm.</u>	
1/2	0.500	12.5	16
3/4	0.750	19.0	15
1	1.000	25.0	14

2. Voids in mineral aggregate (VMA), for each plant sample, shall be computed in accordance with the procedures contained in Chapter 5, MARSHALL METHOD OF MIX DESIGN, of the Asphalt Institute’s Manual Series No. 2 (MS-2), Mix Design Methods for Asphalt Concrete.
3. Each mixture shall be evaluated for stripping by performing indirect tensile tests on compacted mixtures. If the Tensile Strength Ratio (TSR) of the composite mixture, as determined by AASHTO T283 with freeze/thaw cycle, is less than 75, the aggregates shall be rejected or the asphalt treated with an approved anti-stripping agent. The amount of anti-stripping agent added to the asphalt shall be sufficient to produce a TSR of not less than 75. If an antistrip agent is required, it will be provided by the Contractor at no additional cost.

2.2 HMA FOR SIDEWALKS AND DRIVEWAYS

- A. HMA for sidewalks and driveways shall conform to the requirements for top mix.

PART 3—EXECUTION

3.1 GENERAL

- A. The Contractor shall install all pavements in the location and to the grades shown on the Drawings, or approved by the Owner. The type and thickness of pavement courses shall be as shown on the Drawings.
- B. Equipment: Maintain equipment in satisfactory operating condition and correct breakdowns in a manner that will not delay or be detrimental to progress of paving operations.

3.2 PREPARATION

- A. Proof roll prepared base material surface to identify areas requiring removal and re-compaction, and to provide a uniform degree of compaction over the entire pavement area.
- B. Do not begin paving work until deficient base material areas have been corrected and are ready to receive paving. Paving shall not be applied until the Owner inspects and approves the finished base.
- C. Check all frames, covers, grates, water valve boxes and other miscellaneous castings that are located in the proposed pavement areas to ensure that all have been correctly positioned and set to the proper slope and elevation. All covers and grates shall be set flush with the required finished surface. No depressions or mounds will be permitted in the pavement to accommodate inaccuracies in the setting of castings.
- D. All vertical surfaces of structures and existing concrete surfaces in contact with new hot mix asphalt pavement shall be painted with a uniform coating of an approved tack coat material. Extreme care shall be exercised in the application of this material to prevent splattering or staining of surfaces that will be exposed after the paving is completed. Surfaces that are stained as a result of the Contractor's operation shall be repaired or replaced at no additional cost to the Owner.
- E. All existing paved surfaces to be overlaid shall be thoroughly cleaned by a self-propelled sweeper. Areas inaccessible by power sweeper shall be broom swept until the pavement surface is clean.

3.3 APPLICATION

A. Tack Coat

1. Apply to contact surfaces of all cement concrete and other surfaces abutting or projecting into pavement.
2. Apply tack coat to existing pavement surfaces to receive HMA overlay at a rate of 0.03 to 0.06 gallons per square yard of residual asphalt on the surface.
3. When the intermediate (binder) course pavement is exposed to construction and or local traffic for more than 30 days or when the surface becomes contaminated with silt, a tack coat shall be applied prior to the surface course pavement at a rate of 0.03 to 0.06 gallons per square yard of residual asphalt on the surface.
4. Allow to dry until at proper condition to receive paving.

- B. Weather Limitations: The hot mix asphalt shall not be placed when weather conditions of fog or rain prevail or when the pavement surface or base shows signs of free moisture (film of water). When the surface temperature of the underlying course is less than 50°F (10°C) the Contractor shall determine the time available for compaction. The time available for compaction shall be calculated based on the time, date, air temperature, average wind speed, sky conditions, latitude, mix type, PG grade, lift thickness, mix delivery temperature, existing surface type, existing moisture content of surface, existing state of moisture in surface, and surface temperature. The estimated time available for compaction can be calculated with the computer program called Pave Cool Tool 2.0.

This program is available at the following web location:

http://mnroad.dot.state.mn.us/research/mnroad_project/restools/cool_tool.asp

The information regarding the air temperature, average wind speed, sky conditions, mix delivery temperature, and existing moisture conditions shall be evaluated by the Owner and a Contractor's representative located at the paving operation. The estimated time available for compaction shall be provided by the Contractor to the Owner. The Owner and the Contractor shall determine if there is an adequate amount of time available to compact the mixture. Options can be explored to extend the time available for compaction. If there is an adequate amount of time available to compact the mixture, the temperature requirements may be waived by the Owner; however all other requirements including compaction shall be met. The Contractor assumes responsibility for constructing the pavement to meet compaction and specification requirements.

The Owner will not permit work to continue when overtaken by sudden storms until the pavement surface shows no signs of free moisture. The material in transit at the

time of shutdown will not be placed until the pavement surface shows no signs of free moisture, provided the mixture is within temperature limits as specified

3.4 HOT MIX ASPHALT PAVEMENT PRODUCTION AND PLACEMENT

- A. Asphalt Binder Material: The Contractor shall set aside one (1) 1-qt samples of the asphalt binder material obtained from each truckload, shipment, or equivalent of asphalt binder material shipped to the production facility. Each sample shall be labeled with the PG grade, source and batch number, quantity, project name, plant, date, and the sampling inspector. The Contractor shall maintain documentation in the form of a Materials Certificate of each shipment, with a copy attached to each quart sample.

After receiving the quart samples, obtained by the Contractor, the Owner may test the samples for verification of the performance grade. Material shall conform to the specification requirements for the applicable performance grade as specified herein. Material not conforming to specification requirements shall be subject to corrective action, production suspension, rejection, removal, or reduced payment as determined by the Owner.

- B. Job Mix Formula (JMF): No HMA shall be produced until a JMF has been submitted by the Contractor and approved by the Owner. The HMA shall be designed using procedures contained in Chapter 5, MARSHALL METHOD OF MIX DESIGN, of the Asphalt Institute's (AI) Manual Series No. 2 (MS-2), Mix Design Methods for Asphalt Concrete, and shall meet the requirements of Table 3 and Table 4 in this specification.

All tests for initial aggregate submittals necessary to determine compliance with requirements specified herein shall be made by the Contractor.

A separate job mix formula shall be submitted for each mixture and each approved RAP stockpile (the stockpile shall be of a uniform quality throughout).

- C. Sampling: The Contractor shall submit representative samples from actual sources of supply for all aggregates to be used for the production of HMA. ASTM D75 shall be used in sampling coarse aggregate and fine aggregate, and ASTM C 183 shall be used in sampling mineral filler. Sampling may be observed and supervised by the Owner or his representative. No aggregate shall be used in the production mixtures without prior approval.

The approved JMF for each mixture shall be in effect until modified in writing by the Contractor. Should a change in sources of materials be made, a new JMF must be developed and approved before the new material is used. All mixture furnished for the work shall conform to the job mix formula within the tolerance ranges as specified.

- D. JMF Tolerances: The job mix formula with the allowable tolerances shall govern the production limits for the aggregate gradation for each mixture. Liquid asphalt contents shall be within the limits stated in TABLE 3.

TABLE 5
JOB MIX FORMULA TOLERANCES
(BASED ON A SINGLE TEST)

<u>Material</u>	<u>Tolerance</u> <u>Plus or Minus</u>
Aggregate passing No. 4 sieve or larger	7 percent
Aggregate passing No. 8 and No. 16 sieves	4 percent
Aggregate passing No. 30 sieve	4 percent
Aggregate passing No. 50 and No. 100 sieves	4 percent
Aggregate passing No. 200 sieve	2 percent
Asphalt Binder	0.3 percent
Temperature of Mix	20 degrees F (-7 C)

- E. Hot Mix Asphalt Mixing Plants, Haul Vehicles, Pavers and Compactors: Shall conform to RIDOT 1997 Standard Specifications for Road and Bridge Construction, Section 401.03, unless modified herein.
- F. Sampling Platform: A safe and adequate platform or catwalk with stairway and railing shall be provided to accommodate the inspector while checking temperatures and obtaining samples of the mixture from haul vehicles. The height of the platforms and raised platforms shall be adequate to accommodate safe acquisition of mix samples from the type of hauling unit(s) being utilized on the project.
- G. Testing Laboratory: The Contractor or producer shall provide a fully equipped asphalt testing laboratory for control and acceptance testing functions during periods of mix production, sampling, and testing, and whenever materials subject to the provisions of these specifications are being supplied or tested. The laboratory shall provide adequate equipment, space, and utilities as required for the performance of the specified tests. The laboratory and all testing equipment shall be located at the production facility. The Owner shall have priority in the use of the equipment necessary for acceptance testing. The equipment shall conform to the applicable ASTM and AASHTO specification requirements for the specific testing being performed.

Laboratory shall be in compliance with ASTM D3666 latest edition.

The laboratory shall contain all of the equipment necessary to perform testing in accordance with ASTM and AASHTO standards referenced herein and with RIDOT Standard Specifications for Road and Bridge Construction, latest edition, in addition to, those requirements listed below:

- Electronic Balance: 20,000gm capacity minimum, sensitivity 0.1gm.
- Marshall equipment: Automatic HMA compactor mounted in accordance with ASTM D1559 and conforming to specifications for ASTM D1559 which consists of totally enclosed, rigidly mounted operated frame, a standard circular-foot compaction hammer assembly designed to ensure an eighteen (18) inch (457mm) drop regardless of specimen height; and automatic counter that shuts off the power after the set number of hammer drops, and a standard compaction pedestal with guide pins for centering one standard (4-inch diameter) HMA mold at a time.
- The Contractor shall also provide two (2) stability compaction molds conforming to ASTM D1559 and suitable for use with the automatic HMA compactor. Note: The Soil test Model AP-800 automatic HMA compactor and AP-166 stability compaction molds have been found suitable.
- Bulk Specific Gravity determination equipment (AASHTO T-166). In addition, all ancillary and miscellaneous equipment needed to perform the testing in accordance with these specifications shall be provided.

H. Temporary Storage of Hot Mix Asphalt: Use of surge bins or storage bins for temporary storage of hot mix asphalt mixtures will be permitted:

1. For hot mix asphalt containing more than 10% RAP, the storage period shall be established from the Rolling Thin Film Oven (RTFO) residue at 140°F (60°C), tested in accordance with AASHTO T240. Prior to production the Contractor shall recover, by AASHTO T170, a sufficient quantity of the RAP binder. The RAP binder shall be blended with the virgin binder at the JMF percentages. The laboratory RAP-virgin binder blend shall be subjected to the RTFO at 140°F (60°C) and the viscosity of the residue shall establish the maximum viscosity allowed for the binder after silo storage. The viscosity of the residue shall be determined in accordance with AASHTO T202 or AASHTO TP48.
2. If the Owner determines that there is an excessive amount of heat loss, segregation and/or oxidation of the mixture due to temporary storage, use of surge bins or storage bins will be discontinued.

I. Hand Work: Whenever possible, all pavement shall be spread by a self-propelled finishing machine. At inaccessible or irregular areas, pavement may be placed by hand methods. If hand methods are used, the hot mixture shall be spread uniformly to the required depth with hot shovels and lutes. After spreading, the hot mixture shall be carefully smoothed to remove all segregated coarse aggregate and lute marks. Lutes used for hand spreading shall be of the type designed for this use. Material loads shall not be dumped faster than they can be properly spread. Workers shall not stand on the loose mixture while spreading.

- J. Paving Machine Placement: Upon arrival, the mixture shall be placed to the full width by a hot mix asphalt paver. It shall be struck off in a uniform layer of such depth that, when the work is completed, it shall have the required thickness and conform to the grade and contour indicated. The speed of the paver shall be regulated to eliminate pulling or tearing of the hot mix asphalt mat. Unless otherwise permitted, placement of the mixture shall begin along the centerline of a crowned section or on the low side of areas with a one-way slope. The top course in larger parking fields shall be placed in the direction of surface-water flow. The mixture shall be placed in consecutive adjacent strips having a minimum width of 10 feet except where edge lanes require less width to complete the area.
1. The longitudinal joint in one course shall offset the longitudinal joint in the course immediately below by at least 1 foot. Transverse joints in one course shall be offset by at least 10 feet from transverse joints in the previous course.
 2. The placement of the material along the longitudinal joint may be performed by setting the screed to overlay the first mat. The elevation of the screed above the surface of the first mat should be equal to the amount of roll-down expected during compaction of the new mat. The overlapped material shall be bumped by the lutes, if necessary, to optimize the density along the longitudinal joint. Under no circumstances should the overlapped material be broadcast across the mat. Excess material should be removed by hand and returned to the screed.
 3. Trafficking over freshly placed surface course material shall not be permitted until the material has been compacted, and allowed to cool to a temperature of 140°F minimum.
- K. Joints — Make joints between old and new pavements, and between successive days' work, to ensure continuous bond between adjoining work. Construction joints shall have the same texture, density, and smoothness as other sections of paving. Clean contact surfaces and apply tack coat.

3.5 ROLLING AND COMPACTION

- A. The mixture, after being spread, shall be thoroughly compacted by rollers having a minimum weight of 240 pounds per inch of drum width as soon as it will bear the weight of the rollers without undue displacement. The number, weight, and types of rollers and sequences of rolling operations shall be such that the required compaction and surface texture are consistently attained while the mixture is in a workable condition. Rolling shall continue until the surface is of uniform texture, true to grade and cross section, and the required field compaction is obtained. The number of rollers and passes required shall be governed by the compaction results; however, at least two rollers shall be provided for each paver employed on the paving operation. Each roller shall be operated by a competent, experienced roller operator and shall be kept in as nearly continuous operation as practicable while work is underway. A plate shall be attached to each roller showing the ballasted and unballasted weight per length-width of tread.

- B. Compact mixture with hot hand tampers, hand rollers, or vibratory plate compactors in areas inaccessible by self-propelled rollers.
- C. Accomplish breakdown or initial rolling immediately following rolling of joints and outside edge. Check surface after breakdown rolling, and repair displaced areas by loosening and filling, if required, with hot material.
- D. Follow breakdown rolling as soon as possible, while mixture is hot. Continue rolling until mixture has been thoroughly compacted.
- E. Perform finish rolling while mixture is still warm enough for removal of roller marks. Continue rolling until roller marks are eliminated and course has attained specified density.
- F. Remove and replace paving areas mixed with foreign materials and defective areas and fill with fresh, hot top or intermediate course material. Compact by rolling to specified surface density and smoothness.
- G. After final rolling, do not permit vehicular traffic on pavement until it has cooled and hardened. Erect barricades to protect paving from traffic.

3.6 HMA SIDEWALKS

- A. Forms: Where walls, curbing or other suitable permanent supports are not present, satisfactory forms shall be installed to assist in securing alignment and adequate compaction of the courses. All forms shall be removed after paving has been completed and the area backfilled and compacted.
- B. Placing HMA: The HMA walkway surface shall be laid in two courses to a depth after compaction of [2-1/2] inches. The bottom course shall be [1-1/4] inch in thickness after compaction, and its surface after rolling shall be parallel to the proposed grade of the finished surface. The top course shall be [1-1/4] inch in thickness after compaction.

Unless otherwise directed, the walkway shall have a 1.50% slope to provide for proper drainage and shall conform to handicap accessibility requirements.

- 1. Spreading Mixture. The mixture shall be dumped, as needed, into a self-propelled sidewalk paver, or into wheel barrows or an approved steel dump sheets outside the areas on which it is to be placed. It shall then be immediately distributed into place by means of shovels and lutes into a uniformly loose layer to the full width required and of such depth that, when the work is completed, it shall conform to the grade and surface contour required.

2. Rolling. The surface shall be rolled with a self-propelled tandem roller weighing not less than 1-1/2 tons and not more than 5 tons. In places not accessible to a power roller, compaction shall be obtained by means of mechanical rammers or by hand tampers weighing not less than 50 pounds and having a tamping face not exceeding 100 square inches.
3. Testing Surface. When tested with a 10-foot straightedge placed parallel to the centerline of the courses, there shall be no deviation from a true surface in excess of 1/4 of an inch.

3.7 FIELD QUALITY ASSURANCE

- A. Independent Testing Laboratory, selected and paid for by the Owner, may be retained to perform construction testing of in-place HMA courses for compliance with requirements for density, thickness and surface smoothness. Top and base courses will be randomly cored by the testing laboratory technicians at a minimum rate of three cores for every course and construction phase or 40,000 square feet of paving, however, no less than three cores in light duty areas and three cores in heavy duty areas will be obtained.

Samples of all material including compacted specimens and certified copies of all reports and printouts shall be made available to the Owner or his representative as often as requested including:

1. Performance Graded Binders
2. Recycling agents
3. Virgin aggregates
4. Reclaimed pavement materials
5. Loose and compacted mixture specimens
6. Combined aggregate samples

- B. Grade Control: Establish and maintain required lines and elevations.
- C. Thickness: In-place compacted thickness shall not be less than the thickness specified on the drawings. Areas of deficient paving thickness shall receive a tack coat and a minimum 1-inch compacted thickness overlay; or shall be removed and replaced to the proper thickness, at the discretion of the Owner, until specified thickness of the course is met or exceeded, at no additional cost to the Owner.
- D. Surface Smoothness: Testing shall be performed on the finished surface of each course for smoothness, using a 10-foot straightedge applied parallel with, and at right angles to centerline of paved area. The results of these tests shall be made available to the Owner upon request. Surfaces will not be acceptable if they exceed the following tolerances for smoothness:

Intermediate (binder) course:	3/8 inch
Top course:	1/4 inch

- E. Check surface areas at intervals necessary to eliminate ponding areas. Remove and replace unacceptable paving as directed by Owner.
- F. Compaction: The in-place compaction of each course shall be compacted to a density of at least ninety-two (92.0) percent and no more than ninety-seven (97.0) percent of the theoretical density. Density shall be calculated in accordance with one of the following standards:
1. Bulk Specific Gravity and Density of Compacted Bituminous Mixture Using Paraffin-Coated Specimens: ASTM D-1188.
 2. Bulk Specific Gravity of Compacted Bituminous Mixtures Using Saturated Surface Dry Specimens: ASTM D-2726.
 3. The theoretical maximum specific gravity for the mixture shall be measured for each sample in accordance with AASHTO T209, Type C, D, or E container.

Areas of insufficient compaction shall be delineated, removed, and replaced in compliance with the specifications at no additional cost to the Owner.

- G. Control Strip: If it is determined, during the performance of the contract, that the material does not conform to the material acceptance requirements, the Owner may order the contractor to cease all operations and construct a CONTROL STRIP consisting of a sufficient quantity of HMA according to the JMF. The contractor shall construct a test section 300 feet (90m) long by, 20 to 30 feet (6 to 9m) wide placed in two lanes, with a longitudinal cold joint, and shall be of the same depth specified for the construction of the course which it represents. The underlying grade or pavement structure upon which the control strip is to be constructed shall be the same as the remainder of the course represented by the control strip. The equipment used in construction of the control strip shall be the same type and weight to be used on the remainder of the course represented by the control strip. A control strip may be required if a change is made in the Job Mix Formula, sources of supply, or paving and rolling equipment.
1. The mixture shall be prepared, placed, and compacted in accordance with this specification. When the control strip pavement has cooled sufficiently, a total of six, Six-inch (6") diameter core samples of the finished pavement including three (3) core samples that span the longitudinal joint shall be taken and tested for conformance to compaction requirements. The material will also be evaluated for conformance to the requirements of plant produced material.
 2. If the tests by the Owner indicate that pavement does not conform to specification requirements, necessary adjustment to JMF, plant operation, placing procedures, and/or rolling procedures shall be made. A second control strip shall than be placed. If the second control strip also does not meet specification requirements, both sections shall be removed at the Contractor's expense. Additional control strips, as required shall be

constructed and evaluated for conformance to the specifications. Any additional sections that are not acceptable shall be removed at the Contractor's expense. No payment will be made for material and labor employed, either in placement or removal of the nonconforming strip.

3. In no case shall the test result of any one mat core density fall below 90% of theoretical and 88% of theoretical for joint compaction.

3.8 MATERIAL ACCEPTANCE

- A. Acceptance Sampling and Testing: All acceptance sampling and testing necessary to determine conformance with the requirements specified in this section may be performed by the Owner or his representative.
 1. Plant Produced Material. Plant produced material may be tested for gradation, asphalt content, and air voids on a random basis, in accordance with ASTM D3665. Sampling shall be from material deposited into trucks at the plant or from trucks at the job site. Where more than one plant is simultaneously producing material for the job, the random sample will be obtained from one facility and considered representative of the day's production.
 - a. Sampling. Each sample, obtained by the Owner or his representative and selected on a random basis, will consist of sufficient material for preparation of test specimens. One set of laboratory compacted specimens will be prepared for each sample in accordance with AASHTO T245, at the number of blows required by Table 3. Each set of laboratory compacted specimens will consist of two test portions prepared from the same field sample.
 - b. The sample of HMA may be reheated in a covered metal tin and placed in an oven to obtain the compaction temperature. The compaction temperature of the specimens will be as specified in the job mix formula.
 - c. Testing. Sample specimens shall be tested for bulk specific gravity in accordance with AASHTO T166 or T275; whichever is applicable, for use in computing air voids.
 - d. The theoretical maximum specific gravity for the mixture shall be measured for each sample in accordance with AASHTO T209, Type C, D, or E container. Samples shall be taken on a random basis, in accordance with ASTM D3665. The value used in the field placed void computations shall be the average of all maximum specific gravity measurements for each course and construction phase
 - e. Asphalt Binder Content: Extraction tests may be performed once per sample in accordance with AASHTO T164 or AASHTO T308 for determination of asphalt content. The weight of ash portion of the

extraction test, as described in AASHTO T164, shall be determined as part of the first extraction test performed at the beginning of plant production; and as part of every tenth extraction test performed thereafter, for the duration of plant production. The last weight of ash value obtained shall be used in the calculation of the asphalt content for the mixture. If utilizing AASHTO T308 for asphalt content determination, the calibration process and calibration factor, as described in AASHTO T308, (Determining the Asphalt Binder Content of Hot-Mixed Asphalt by the Ignition Method) shall be determined as stated, prior to acceptance testing. A verification shall be performed as part of every twentieth test performed thereafter or when changes in the mix are apparent.

The use of the nuclear method for determining asphalt content in accordance with AASHTO T287 is permitted, provided that it is calibrated for the specific mix being used.

- f. **Gradation:** Aggregate gradations shall be determined once for each sample from mechanical analysis of extracted aggregate in accordance with AASHTO T 30 and AASHTO T27 (Dry Sieve). When asphalt content is determined by the nuclear method, aggregate gradation shall be determined from hot bin samples on batch plants, or from the cold feed on drum mix or continuous mix plants, and tested in accordance with AASHTO T27 (dry sieve) using actual batch weights to determine the combined aggregate gradation of the mixture.
2. **Field Placed Material:** Material placed in the field may be tested for mat and joint density, and compacted thickness on a random basis, in accordance with ASTM D3665. No surface course material shall be placed until an evaluation of the intermediate course for specification conformance is completed. The Owner, prior to placement of the surface course, may determine the quality and acceptance for the intermediate course.
 - a. **Mat Compaction.** The lot size shall be the total quantity of each course placed per construction phase or per 200,000 square feet maximum of construction. Three, six-inch diameter cores of finished, compacted material shall be taken by the Owner or the Owner's representative from each course and each lot, or partial lot. Core locations will be determined by the Owner on a random basis. Cores shall not be taken closer than 1 foot (0.3 meters) from a longitudinal joint and 10 feet (3.0 meters) from a transverse joint.
 - b. **Joint Compaction.** The lot size shall be the total length of longitudinal joints constructed by a material course placed per lot of construction. Three (3) cores of finished, compacted materials shall be taken by the Owner or the Owner's representative from each course and each lot, or partial lot. Core locations will be determined by the Owner on a random basis and be located directly over the joint, not adjacent to the joint.

- c. Sampling. Samples shall be neatly cut with a core drill. The cutting edge of the core drill bit shall be of hardened steel or other suitable material with diamond chips embedded in the metal cutting edge. The minimum diameter of the sample shall be 6 inches (152.4mm). Samples that are clearly defective, as a result of sampling, shall be discarded and another sample taken. The Owner or the Owner's representative shall furnish all tools, labor, and materials for cutting samples and filling the cored pavement. Cored holes shall be filled in a manner acceptable to the Owner and within one day after sampling.
- d. Testing. The bulk specific gravity of each cored sample will be measured by the laboratory technician in accordance with AASHTO T166 or T275, whichever is applicable. The theoretical maximum specific gravity shall be measured once for each plant sample in accordance with the plant-produced material section. The theoretical value used for the percent density of the core samples shall be the average of the maximum specific gravity measurements for the material course and construction lot. The percent density of each sample will be determined in accordance with AASHTO T269, using the bulk specific gravity of each sample and the average theoretical maximum specific gravity for the material course and construction lot.

3.9 ACCEPTANCE CRITERIA

- A. General: Acceptance will be based on the following characteristics of the hot mix asphalt and completed pavement on a material course and construction phase basis:

Hot Mix Asphalt Production

Plant air voids
Gradation
Asphalt binder content
Mixture Temperature

Hot Mix Asphalt Placement

Mat density
Joint density
Thickness
Inferior Material
Smoothness
Grade

1. Hot Mix Asphalt Production

- a. Plant Air Voids - The average plant bulk specific gravity shall be determined per set of laboratory compacted specimens. The theoretical maximum specific gravity, for the sample, shall then be used to determine the air voids in accordance with AASTHO T269. Material shall conform to the specification requirements for air voids listed in Table 3. Material not conforming to specification requirements shall be subject to corrective action, production suspension, rejection, removal, or reduced payment.

Corrective action shall be taken by the Contractor when the calculated plant produced air voids per set of laboratory compacted specimens, fall outside the specification range by up to and including 1.5%, either on the high side or the low side. The Contractor shall be required to suspend production when the calculated air voids fall outside the specification range by more than 1.5%, either on the high side or the low side. If two consecutive calculations fall outside the specification range by up to 1.5%, either on the high side or the low side, the Contractor shall be required to suspend production. If production is suspended, the Contractor shall be required to produce material on a trial basis for testing purposes without shipment to the project. The Owner or his representative shall pay for acceptance sampling and testing for the first set of trials, necessary to determine conformance with the specification requirements. If the first set of trials does not conform to specification requirements, the Contractor shall pay for any additional trial sampling and testing for acceptance. When trials have been approved, the plant will return to its normal operation.

- b. Gradation and Asphalt Binder Content: The Contractor shall take corrective action and/or suspension of production when the individual results for asphalt content and/or gradation fall outside the following control limits:

TABLE 6
CONTROL LIMITS FOR INDIVIDUAL MEASUREMENTS

	<u>Sieve Size</u>	<u>Limits</u>	
		<u>Action</u>	<u>Suspension</u>
19.0 mm	25.4 mm	0%	0%
		±6%	±9%
	12.5 mm	±6%	±9%
	9.5 mm	±6%	±9%
	4.75 mm	±6%	±9%
	2.36 mm	±5%	±7.5%
	1.18 mm	±5%	±7.5%
	0.600 mm	±4%	±5.5
	0.300 mm	±3%	±4.5
	0.150 mm	±3%	±4.5
	0.075 mm	±2%	±3%
Asphalt Binder Content		±0.4%	±0.70%

These limits shall be applied to the target values established in the JMF. Corrective action shall be taken by the Contractor when the calculated individual result for gradation or asphalt content falls outside the target JMF value beyond the action limit listed in Table 6. The Contractor shall take the appropriate action when results indicate the material is out of tolerance. The Contractor shall be required to suspend production when the calculated individual result for gradation falls outside the target JMF value beyond the suspension limit listed in Table 6, or when the asphalt binder content is below the minimum values stated in Table 3. The Contractor shall be required to suspend production if two points in a row fall outside the Action Limits for individual measurements. If production is suspended, the Contractor shall be required to produce material on a trial basis for testing purposes without shipment to the project. The Owner or his representative shall pay for acceptance sampling and testing for the first set of trials, necessary to determine conformance with the specification requirements. If the first set of trials does not conform to specification requirements, the Contractor shall pay for any additional trial sampling and testing for acceptance. When trials have been approved, the plant will return to its normal operation.

- c. Mixture Temperature: The temperature of the mixture shall be in accordance with the Performance Graded Asphalt Binder (PGAB) allowable mixing and compaction temperature range.
- d. Failure to stop production and make adjustments when required due to an individual test not meeting the specified requirements shall subject all mix from the stop point to the point when the next individual test is back on or within the action limits, or to the point when production is actually stopped, whichever occurs first, to be considered unacceptable. This material shall be removed and replaced with materials that comply with the specifications at the Contractor's expense.

2. Hot Mix Asphalt Placement

- a. Mat Density and Joint Density: Mat and Joint Density will be evaluated based on the test results obtained by the Owner. Sampling and testing shall be performed in accordance with Section 3.07 Field Quality Assurance.

The bulk specific gravity shall be determined for each compacted core specimen. The theoretical maximum specific gravity shall then be used to determine the density of the compacted specimen in accordance with AASHTO T269, using the bulk specific gravity of each sample and the average theoretical maximum specific gravity for the material course and construction lot.

$$\text{Density} = (G_{mb}/G_{mm}) \times 100$$

Where G_{mb} = bulk specific gravity of compacted specimen

G_{mm} = theoretical maximum specific gravity

HMA material shall conform to the specification requirements for density listed below. Material not conforming to specification requirements shall be subject to corrective action, production suspension, rejection, removal, or reduced payment as determined by the Owner.

1. Mat Density. The in-place density of each course shall be compacted to a density of at least ninety-two (92.0) percent and no more than ninety-seven (97.0) percent of the theoretical density as determined from field or plant samples.
 2. Joint Density. The in-place density of each course shall be compacted to a density of at least ninety (90.0) percent and no more than ninety-seven (97.0) percent of the theoretical density as determined from field or plant samples.
 3. Acceptance of field placed material for mat density and joint density will be based on the test results obtained by the Owner.
- b. Thickness Determinations: The compacted thickness shall be evaluated based on the test results obtained by the Owner. Sampling and testing shall be performed in accordance with Section 3.07 Field Quality Assurance. The thickness requirements shall apply only when each pavement layer is specified to be a uniform compacted thickness of 1 inch (25mm) or greater. The compacted thickness of each layer of the hot mix asphalt or mixes will be measured to determine compliance with the acceptance tolerances in Table 7. Thickness shall be evaluated for

compliance by the Owner to the requirements shown on the plans. The thickness shall be determined for each compacted core specimen in accordance with ASTM D3549.

TABLE 7
THICKNESS ACCEPTANCE TOLERANCES

Specified Thickness	<u>Allowable Tolerances (T)</u>
1 inch to 2 inches	±1/4 inch
2 inches+ to 5 inches	±3/8 inch
Over 5 inches	±1/2 inch

Material shall conform to the specification requirements for thickness listed above. Material not conforming to specification requirements shall be subject to corrective action, production suspension, rejection, removal, or reduced payment as determined by the Owner.

- c. Inferior Material: The Owner may at any time, notwithstanding previous acceptance, notify the Contractor of inferior material and recommend the rejection of any batch of HMA which is rendered unfit for use due to contamination, segregation, incomplete coating of aggregate, or improper mix temperature. Such recommendation may be based on only visual inspection or temperature measurements. In the event of such notification, the Contractor should evaluate and dispose of any inferior material. If inferior material is not rejected by the Contractor, the Owner will take a representative sample of the rejected material in the presence of the Contractor, and if it can be demonstrated in the laboratory, that such material was erroneously incorporated into the work, payment will not be made for that material and the Contractor will remove and replace the defective material identified by the Owner.
- d. Smoothness: The finished surfaces of the pavement shall be uniform in appearance, free from irregularities in contour and texture and shall present a smooth-riding surface. Smoothness evaluation applies to all hot mix asphalt concrete roadways receiving 1.5" (38mm) or more in plan (compacted) thickness
 1. The finished surface of the pavement shall not vary more than 1/4 inch (6.2mm) for the surface course and 3/8 inch (9.5mm) for the intermediate course. Each area shall be evaluated with a 10-foot (3.0m) straightedge.
 2. Measurements will be made perpendicular and parallel to the paver passes at distances not to exceed 50 feet (15.2m).

3. When profile corrections are required, the Contractor shall use one or more of the following corrective methods:
 - (a) Removing and replacing the entire pavement thickness;
 - (b) Diamond grinding or micro milling;
 - (c) Overlaying (not patching) with the specified surface course;
 - (d) Removing the surface by milling and applying a lift(s) of the specified course(s);
 - (e) Use of other methods that will provide the desired results;
- e. Grade: The finished surface of the pavement shall not vary from the gradeline elevations and cross sections shown on the plans by more than 1/2 inch (12.70 mm). The Contractor shall remove deficient areas and replace with new material. Sufficient material shall be removed to allow at least 1.5 inches (37.5mm) of hot mix asphalt to be placed. Skin patching for correcting low areas shall not be permitted. High points may be ground off. The Contractor shall make tests for conformity with the specified crown and grade immediately after initial compaction. Any variation shall be corrected by the removal or addition of materials and by continuous rolling.
- f. Shaping Edges: While the surface is being compacted and finished, the Contractor shall carefully trim the unsupported outside edges of the pavement not receiving curbing. Edges so formed shall be beveled while still hot with the back of a lute or smoothing iron and thoroughly compacted by tampers or by other satisfactory methods.
- g. The corrective method(s) chosen by the Contractor shall be performed at the Contractor's expense, including all necessary equipment and traffic control.
 - (1) Areas of removal and replacement shall be removed the full width of the paver pass. The removal areas shall be reconstructed with a transverse butt joint, using a transverse saw cut perpendicular to the paver pass.
 - (2) Replacement materials shall be placed in sufficient quantity so the finished surface will conform to grade and smoothness requirements. The corrective area shall conform to all material and compaction specification requirements.
 - (3) When the corrective work consists of an overlay, the overlay shall cover those paver passes sufficient to correct the defects. The area overlaid shall be placed with a transverse butt joint using a transverse saw cut and asphalt removal.
 - (4) All materials shall meet contract requirements. The overlay shall be placed so the finished surface will conform to grade and smoothness

requirements. The overlay area shall be compacted to the specified density.

- (5) The Owner shall retest any sections where corrections were made to verify that the corrections produced a surface that conforms to the grade and smoothness requirements.

3.10 MEETING EXISTING PAVEMENTS

- A. Where new pavements will abut existing pavements, the Contractor shall sawcut the existing pavements to produce a uniform, smooth joint surface. Sawcutting of existing pavements shall be neat, straight and even lines, and done in a manner that prevents damage to the pavement to remain.
- B. Full-Depth Pavement: Sawcut by approved method to the full depth of the pavement prior to placement of any new pavement. The sawcut surface shall be a neat true line with straight vertical edges free from irregularities. The sawcut surface shall be tack coated immediately prior to the installation of the new abutting HMA material to provide a bond between the old and new pavement. The new compacted pavement surface shall be finished flush with the abutting pavement.
- C. HMA Overlays: The existing hot mix asphalt pavement shall be sawcut to a neat true line with straight vertical edges free of irregularities for a minimum depth of one and one half inches. Prior to completing overlays, existing pavements shall be tapered by grinding. The taper, along the entire length of the joint, shall be one and one-half inches deep at the sawcut face and shall taper to zero inches deep toward the overlay at a distance of two feet from the sawcut face in driveways and at a distance of six feet in roadways and parking areas. The taper shall be cleaned and shall receive an asphalt emulsion tack coat immediately prior to placement of the overlay. The new compacted surface at the joint shall be flush with the abutting existing pavement.
- D. Immediately prior to the placement of the HMA overlay, the sawcut edges of the existing pavement shall be tack coated to bond the new pavement to the old pavement. The new pavement surface shall be finished flush with the abutting pavement. The surface seam of the pavement joint shall be sealed with tack coat and back sanded.

END OF SECTION 32 12 15

APPENDIX A TO SECTION 32 12 15

METHOD OF TEST FOR
BULK SPECIFIC GRAVITY OF AGGREGATE BLENDS WITH RAP

1.0 SCOPE

- 1.1 This test method covers the procedure to determine the bulk specific gravity (Gsb) of a combined aggregate blend with RAP used in a HMA mixture.
- 1.2 This test method may involve hazardous materials, operations, and equipment. This test method does not purport to address all of the safety problems associated with the test method's use. The test method user's responsibility is to establish appropriate safety and health practices and determine the applicability of regulatory limitations prior to use.

2.0 REFERENCED DOCUMENTS

- 2.1 AASHTO Standards
 - T-2 Sampling Aggregates
 - T-84 Specific Gravity and Absorption of Fine Aggregates
 - T-85 Specific Gravity and Absorption of Coarse Aggregate
 - T-100 Specific Gravity of Soils
 - T-164 Quantitative Extraction of Bitumen from Bituminous Paving Mixtures
 - T170 Recovery of Asphalt From Solution by Abson Method
 - T-209 Maximum Specific Gravity of Bituminous Paving Mixtures
 - T-228 Specific Gravity of Semi-Solid Bituminous Materials (Pycnometer Method)
- 2.2 Other References
 - MS-2 Mix Design Methods for Asphalt Concrete by the Asphalt Institute

3.0 TERMINOLOGY

3.1 Terms and Abbreviations. Definitions for terms and abbreviations shall be in accordance with the Standard Specifications.

4.0 SIGNIFICANCE AND USE

4.1 This test method is used to determine the bulk specific gravity of a combined aggregate blend with RAP used in HMA mixture.

4.2 The bulk specific gravity (Gsb) of a combined aggregate blend is calculated using an estimate of the bulk specific gravity of the aggregate in the RAP and the actual bulk specific gravity of the other aggregates.

4.3 The bulk specific gravity of an aggregate blend is used to perform a volumetric analysis on compacted HMA in accordance with the Mix Design Methods for Asphalt Concrete by the Asphalt Institute.

5.0 APPARATUS

5.1 Apparatus shall be as stated in the referenced test methods.

6.0 SAMPLING

6.1 Sampling shall be as stated in the referenced test methods.

7.0 PROCEDURE

7.1 Identify the coarse aggregate(s), fine aggregate(s), and RAP selected for use in the mix designs.

- 7.2 Identify and record the actual percentages for each of the aggregate components used in the combined aggregate blend of the mix design.
- 7.3 Obtain a representative sample of the coarse aggregate, fine aggregate, mineral filler, and RAP in accordance with the AASHTO procedures.
- 7.4 Determine and record the bulk specific gravity of each of the coarse aggregate(s) in accordance with AASHTO T-85.
- 7.5 Determine and record the bulk specific gravity of each of the fine aggregate(s) in accordance with AASHTO T-84.
- 7.6 Determine and record the maximum specific gravity of the RAP in accordance with AASHTO T-209, Type C, D, or E container.
- 7.7 Determine and record the asphalt content of the RAP using AASHTO T164.
- 7.8 Calculate and record the effective specific gravity of the RAP aggregate in accordance with the following:

$$G_{se} = (100 - P_{brap}) / ((100 / G_{mmrap}) - (P_{brap} / G_{brap}))$$

Where:

G_{se} = Effective specific gravity of the RAP aggregate

P_{brap} = Percent binder of the RAP

G_{mmrap} = Maximum specific gravity of the RAP

G_{brap} = Specific gravity of asphalt in the RAP (AASHTO T228)

- 7.9 Calculate and record the effective specific gravity of the combined aggregate blend as follows.

$$G_{sbBlend} = \frac{\frac{\%CA1}{G_{sb}} + \frac{\%CA2}{G_{sb}} + \frac{\%FA1}{G_{sb}} + \frac{\%FA2}{G_{sb}} + \frac{\%BHF}{G_{sb}} + \frac{\%RAP}{G_{se}}}{\%CA1 + \%CA2 + \%FA1 + \%FA2 + \%BHF + \%RAP}$$

Where:

GsbBlend = Bulk specific gravity of the combined aggregate blend.

Gsb = Bulk specific gravity of each respective aggregate.

Gse = Effective specific gravity of the RAP.

%CA1 = Percent of aggregate blend that is coarse aggregate #1.

%CA2 = Percent of aggregate blend that is coarse aggregate #2.

%FA1 = Percent of aggregate blend that is fine aggregate #1.

%FA2 = Percent of aggregate blend that is fine aggregate #2.

%BHF = Percent of aggregate blend that is bag house fines.

%RAP = Percent of aggregate blend that is RAP.

8.0 REPORT

- 8.1 Report the Gsb of the combined aggregate blend to the nearest 0.001.

END OF SECTION 32 12 15

THIS PAGE INTENTIONALLY LEFT BLANK

SECTION 32 16 10

CURBING

PART 1 GENERAL

1.1 DESCRIPTION

- A. This Section specifies requirements for furnishing and installing all types of curbing including the following: granite curb, concrete curbs, and granite and concrete edging.
- B. The work includes:
 - 1. Furnishing and installing granite curb, granite edging, curb inlets, and curb corners, precast concrete curb, and cast-in-place concrete curb.
 - 2. All associated items and operations required to complete the installations, including surface preparation, concrete support, jointing, and finishing.

1.2 RELATED SECTIONS

- A. Sections which directly relate to the work of this Section include:
 - 1. Section 31 00 00 – EARTHWORK.
 - 2. Section 32 12 15 – ASPHALT PAVING.

1.3 REFERENCE STANDARDS

- A. References herein are made in accordance with the following abbreviations and, all work under this Section shall conform to the latest editions as applicable.
- B. ACI 304 - Guide for Measuring, Mixing, Transporting and Placing Concrete.
- C. ANSI/ASTM D1751 – Standard Specification for Preformed Expansion Joint Filler for Concrete Paving and Structural Construction (Nonextruding and Resilient Bituminous Types).
- D. ANSI/ASTM D1752 – Standard Specification for Preformed Sponge Rubber, Cork, and Recycled PVC Expansion Joint Fillers for Concrete Paving and Structural Construction.
- E. ASTM C33 – Standard Specification for Concrete Aggregates.
- F. ASTM C94 – Specification for Ready-Mixed Concrete.
- G. ASTM C150 – Standard Specification for Portland Cement.
- H. ASTM C260 – Standard Specification for Air-Entraining Admixtures for Concrete.
- I. ASTM C309 – Standard Specification for Liquid Membrane-Forming Compounds for Curing Concrete.

- J. ASTM C494 – Standard Specification for Chemical Admixtures for Concrete.

1.4 SUBMITTALS

- A. Submit shop drawings and manufacturer's literature for granite and precast curb, edging, corners and inlets indicating size, shape and dimensions, finish, and setting method for Engineer's approval.
- B. Submit copies of tests on representative samples of the concrete used in the manufacture of precast units showing a compressive strength of 5,000 psi to the Engineer prior to shipping any units.

1.5 DELIVERY, STORAGE AND HANDLING

- A. Granite and precast curb units shall be adequately protected from damage during transit to the site.
- B. Curbing shall be protected against staining, chipping, and other damage. Cracked, badly chipped, or stained units will be rejected and shall not be employed in the work.

1.6 SAMPLES

- A. The Contractor shall supply to the site three (3) samples of all curb types for approval prior to ordering materials. Approved sample material may be used in the work upon approval by the Engineer.

PART 2 PRODUCTS

2.1 PRECAST CONCRETE CURB

- A. The concrete shall have a minimum compressive strength of 5,000 psi at 28 days, and shall contain 5 to 7 percent entrained air. The material shall conform to RIDOT 2010 Standard Specifications for Road and Bridge Construction (including all addenda and revisions), Section 601, unless modified herein.
- B. All precast curb with radius of 100 foot or less shall be formed to the radius shown on the Drawings.
- C. Precast concrete curb units shall be rubbed finished, as follows:
 - 1. After the concrete has properly hardened, the exposed surfaces shall be rubbed with a #16 carborundum stone or an approved abrasive to fully remove laitance and sand grain finish. No cement shall be used in the rubbing process.

- 2. The finish of the units shall be uniform and shall conform to those of adjacent work in their final position.
- D. Precast concrete curb sections shall be furnished with sockets in each end to receive dowels to maintain the horizontal and vertical alignment of the curb. The dowel socket shall be 1 1/16 inch by 2-1/2 inches. Provide 5/8 inch by 4 inch dowels.

2.2 CEMENT MORTAR

- A. Cement mortar shall be composed of one part Portland cement and two parts of sand by volume with sufficient water to form a workable mix. Cement shall be Portland cement ASTM C150, Type II.

2.3 TRANSITION SECTIONS

- A. Horizontal transition sections shall be provided at all locations where curb sections change (i.e., vertical to sloped). Vertical transition sections shall also be provided for precast curb sections at wheelchair ramps. Vertical transition sections for granite curb shall be made as shown on the Drawings.

PART 3 EXECUTION

3.1 GENERAL

- A. Trenching, excavation, backfilling, and compaction shall be completed in accordance with Section 31 00 00 – EARTHWORK, except as modified within this Section.
- B. Cement mortar bedding, if required, shall be placed as shown on the Drawings and in accordance with RIDOT 2010 Standard Specifications for Road and Bridge Construction (including all addenda and revisions), Section 601, unless modified herein.

3.2 GRANITE CURB AND EDGING INSTALLATION

- A. Excavation shall extend 6 inches below and behind curb, as shown on the Drawings.
 - 1. The gravel base shall be placed in the excavated area, graded and compacted to above the proposed curb subgrade.
- B. Curbing and curb corners shall be set on additional gravel spread upon the foundation. All spaces under the curb and curb corners shall be filled with gravel thoroughly compacted so that the curb and curb corners will be completely supported throughout their length. The curb shall be set at the line and grade required as shown on the plans unless otherwise directed.

- C. Edging shall be set on a thoroughly compacted base so that the edging will be completely supported throughout their length. Concrete shall be placed to support the edging base as shown on the plans.
- D. Curb, curb corners or edging shall be fitted together as closely as possible.
- E. Immediately after the curb, curb corners, curb inlets, and edging is set, the space between it and the wall of the trench shall be filled with gravel thoroughly tamped to a depth of 6 inches, care being taken not to affect the line or grade of the curb, curb corners, curb inlets and edging. The trench shall continue to be filled with gravel and compacted in 6 inch lifts until grade is achieved. If the curb materials and trench are part of reconstruction work and existing bituminous concrete surface is to remain, then the use of concrete backfill is acceptable, to an elevation suitable to support the pavement patch or section.
- F. The joints between curbstones (both front and back) or edging shall be carefully filled with cement mortar and neatly pointed on the top and front exposed portions. After pointing, the curbstones or edging shall be satisfactorily cleaned of all excess mortar that may have been forced out of the joints.
- G. Transitions from normal curb settings to wheelchair ramps shall be accomplished with transition curb as shown on the drawings. Transitions shall be of the same type curb and similar to that abutting the transition piece and, if on a curve, of the same radius.
- H. The ends of the stone curb at driveways and intersections shall be cut at a bevel or rounded, as shown on the Drawings.
- I. If curb, curb corners, curb inlets, or edging of different quarries is used on the same project, curbing of each particular quarry shall be segregated and set to give uniform appearance.
- J. Procedures for removal and resetting of existing granite curb, and new granite curb, in existing pavements shall include the following:
 - 1. Prior to excavation for existing granite curb removal, the pavement surface shall be saw cut a minimum of one foot from the face of curb.
 - 2. Existing curb shall be carefully excavated, and removed in a manner that protects the curb and existing pavement to remain from damage.
 - 3. Existing granite curb shall be cleaned by sandblasting as required to remove bituminous material, paint and concrete from exposed surfaces prior to resetting in the proposed work.
 - 4. New granite curb shall be set to match the top of existing granite curb remaining in place at abutting sections and, if required, transitioned to the typical section shown on Drawings within the first section of curb. Cement concrete shall be placed along the front face of the curb as shown on the Drawings.

3.3 PRECAST CONCRETE CURB

- A. Precast units delivered to the site shall be inspected for damage, unloaded and placed along the prepared curb trench, or other designated location, with the minimum amount of handling.
 - 1. Materials shall be handled in a manner that prevents damage to the curb units.
 - 2. All individual pieces of curved curbing shall be marked to correspond to the radius and location where curbing is to be set.

- B. Excavation shall extend 6 inches below and behind finished curb, as shown on the Drawings.
 - 1. The gravel base shall be placed in the excavated area, compacted and graded to the proposed curb subgrade.

- C. Precast concrete curb units shall be doweled together continuously to the line and grade shown on the Drawings. Any units damaged during setting operations shall be removed and replaced.

- D. After the curb is set, the trench shall be backfilled immediately with approved material. The first layer shall be 4 inches in depth and compacted. The other layers shall be not more than 6 inches in depth and compacted until the trench is filled. Care shall be taken to prevent disturbing the line or grade of the curb during this procedure.

END OF SECTION 32 16 10

THIS PAGE INTENTIONALLY LEFT BLANK

SECTION 32 17 23

PAVEMENT MARKINGS

PART 1 - GENERAL

1.1 DESCRIPTION

- A. This Section specifies requirements for removal of existing pavement markings and construction of new pavement markings.
- B. The work includes:
 - 1. Removal of existing markings by approved methods.
 - 2. Pavement surface preparation.
 - 3. Furnishing and installing new pavement markings.

1.2 RELATED SECTIONS

- A. Sections which directly relate to the work of this Section include:
 - 1. Section 31 00 00 - EARTHWORK
 - 2. Section 32 16 10 - CURBING

1.3 SITE CONDITIONS

- A. The Contractor shall cordon off areas where markings are being applied, but maintain access for vehicular and pedestrian traffic as required for other construction activities. Flagmen, barricades, drums, warning signs, warning lights, and similar devices shall be used as required.

1.4 SUBMITTALS

- A. Submit material certificate to the Engineer, signed by the material producer and Contractor, certifying that materials comply with these specifications and have been approved for use by the Rhode Island Department of Transportation(RIDOT).

PART 2 - PRODUCTS

2.1 MATERIALS

- A. Pavement markings shall conform to Section T.20 and Section M.17 of the current Rhode Island Department of Transportation Standard Specifications for Road and Bridge Construction and Manual of Uniform Traffic Control Devices, current editions.

- B. Traffic markings shall be yellow or white Traffic Marking Paint and shall be on the RIDOT Approved Materials list.
- C. Markings are to be epoxy-based.

PART 3 - EXECUTION

3.1 PREPARATION

- A. The Contractor shall clean the pavement of dust, dirt, old pavement markings, concrete curing compounds, and other foreign material which may be detrimental to the adhesion of the pavement marking materials.

3.2 REMOVAL OF EXISTING PAVEMENT MARKINGS

- A. Existing pavement markings that conflict with the proposed markings and those shown on the Drawings shall be removed.
 - 1. Pavement markings shall be removed before any change is made in the traffic pattern.
 - 2. Any excessive damage to the pavement caused by pavement marking removal shall be repaired by the Contractor by methods acceptable to the Engineer at no additional cost to the Owner.
- B. Approved methods of pavement markings removal include:
 - 1. Sandblasting using air or water
 - 2. High pressure water
 - 3. Steam or superheated water
 - 4. Mechanical devices such as grinders, sanders, scrapers, scarifiers and wire brushes
- C. Painting over a pavement marking line with asphaltic liquids or paints will not be allowed unless approved by the Engineer.
- D. Material deposited on the pavement from removal operations shall be removed as the work progresses. Accumulations of sand or other material which might interfere with drainage or could constitute a hazard to traffic will not be permitted.
- E. Where sandblasting is used for the removal of pavement markings and the removal operation is being performed within 10 feet of a lane occupied by traffic, the residue, including dust, shall be removed immediately as the marking removal progresses by a vacuum attachment operating concurrently with the blast cleaning operation, or by other methods approved by the Engineer.

3.3 PAVEMENT MARKING APPLICATION

- A. The material shall be applied to the pavement by equipment designed and manufactured specifically for the application of pavement markings.

- B. The Contractor shall employ the services of a registered land surveyor to provide control for layout of pavement markings.
- C. Paint markings shall be applied at a minimum thickness of 15+ 1 mil. Thermoplastic markings shall be applied at 125 to 188 mils thickness.
- D. Pavement markings shall be applied in accordance with the layout shown on the Drawings. No paint shall be applied to new bituminous pavement until the top course has cured at least one week, and allow two weeks curing for newly installed bituminous concrete curbing.
- E. All parking stalls shall be single stripe, and shall be spaced equally. The line indicated on the Drawings is on the center line of the stall marking.
- F. Where entire areas are to be cross-hatched, the striping shall conform to the cross-hatching shown on the Drawings.
- G. All parking stall markings shall be straight with sharp corners and clean edges. Directional arrows, cross-hatching, lane divider stripes, stop lines, and lettering shall be painted white to the size, length, and spacing shown on the Drawings.
- H. All markings shall be applied in one coat with brush, spray, or marking machine over clean dry pavement surfaces, when the atmospheric temperature is at or above 40°F., and when the weather is otherwise favorable in the opinion of the Engineer.
- I. Use only skilled workmen who are experienced and normally employed in the work of installing pavement markings. Supply all the necessary equipment and materials required for the work.
- J. The Contractor shall protect the buildings, walks, pavement, curbing, trees, shrubs, mulch, and other site fixtures from over-spray of paint and damage from pavement marking operations.
- K. Traffic shall not be permitted on the pavement until the paint is thoroughly dry.

END OF SECTION 32 17 23

THIS PAGE INTENTIONALLY LEFT BLANK

SECTION 32 31 13

CHAIN LINK FENCE

PART 1 - GENERAL

1.01 SECTION INCLUDES

- A. Galvanized chain link fencing and hardware

1.02 REFERENCES

- A. ASTM - A153 - Zinc coating on iron and steel hardware
- B. ASTM - A392 - Zinc coated steel chain link fence fabric
- C. ASTM - F1083 - Zinc coatings on products

1.03 SUBMITTALS

- A. Submit shop drawings and product data under provisions of Section 01 33 00.

1.04 QUALIFICATIONS

- A. The manufacturer and installer shall specialize in performing the work of this section with minimum of three years documented experience.

PART 2 - PRODUCTS

2.01 MANUFACTURERS

- A. Cyclone fence
- B. Substitutions under provisions of Section 01 60 00.

2.02 MATERIALS

- A. Fabric: Chain link fabric shall be zinc coated per ASTM-392 Class 2. Fabric shall be woven from 9 gauge (coated size) wire in 2" mech. Fabric shall be knuckled at both selvages.
- B. Line Posts: Line posts shall be 2.375" O.D. standard weight Schedule 40 galvanized pipe with minimum bending strength of 201 pounds under a 6' cantilever load coated with 1.8 ounces of hot dipped zinc in accordance with ASTM-F1083.
- C. Top and Brace Rail: Top and brace rails shall be 1.66" O.D., standard weight Schedule 40 galvanized pipe with minimum vertical bending strength of 202 pounds on 10' span coated with 1.8 ounces of hot dipped zinc in accordance with ASTM-F1083. Top rail couplings 6" minimum in length shall be spaced at maximum 21' centers. Fabric tie wire shall be spaced at 24" maximum centers.

- D. Terminal Posts: All end, corner, and pull posts shall be 2.875" O.D. galvanized standard weight pipe with minimum bending strength of 381 pounds on 6' cantilever load coated with 1.8 ounces of hot dipped zinc in accordance with ASTM-F1083.
- E. Tension Bars: One piece lengths equal to full height of fabric with a minimum cross-section of 3/16 inch by 3/4 inch. Provide tension bars for each end, corner and pull posts.
 - 1. Tension bar bands and clips: Heavy pressed steel, or malleable iron.

2.03 SETTING MATERIALS

- A. Pipe Sleeves: Galvanized "Schedule 40" pipe with I.D. 1/2 inch larger than the O.D. of post, and closed at the bottom with cap or welded plate.
- B. Grout: Quick set POR-ROK expanding concrete as manufactured by Hallemite Manufacturing Company, Cleveland, Ohio or equal.

PART 3 - EXECUTION

3.01 POST INSTALLATION

- A. Layout:
 - 1. End, Corner and Pull Post: Provide at termination and change in horizontal or vertical direction of 30 degrees or more.
 - 2. Line Posts: Space uniformly at approximately 8 feet on center.
 - 3. See drawings for height of fence.
- B. Concrete Set Posts: (Corner, End, and Pull Posts) Drill holes (after final grading) in firm, undisturbed or compacted soil. Holes shall have a diameter equal to 4 times the diameter of the post, and depths approximately 6 inches deeper than post bottom. Excavate deeper as required for adequate support in soft and loose soils, and for posts with heavy lateral loads.
 - 1. Set post not less than 36 inches below when in firm, undisturbed soil.
 - 2. Place concrete around posts in a continuous pour, tamp for consolidation. Trowel finish tops of footings, and slope or dome to direct water away from posts.
- C. Wall-Set Posts: Vertical posts shall be set into built-in steel pipe sleeves extending into concrete or masonry walls at least 16 inches deep. Fill joint between vertical posts and sleeve.
- D. Check each post for vertical and top alignment and hold in position during placement and finishing operations.

3.02 BRACING AND FRAMING

- A. Top Rails:
 - 1. Random length, averaging not less than 18 feet.
 - 2. Pressed steel sleeve joints, for rigid connections and expansion/contraction.

3.03 FABRIC INSTALLATION

- A. Tension Wire: Provide tension line at bottom of fabric. Install tension wires before stretching fabric and tie to each post with ties or clips. Attach to fabric with hog rings 24 inches o.c.

- B. Fabric: Install fabric on security side of fence, and attach to framework so that fabric remains in tension after pulling force is released. Pull fabric taut and tie to posts, rails, and tension wires. Extend bottom of fabric into concrete.
 - 1. Ties: Fabric to rails and braces at 24 inches o.c. and line posts at 14 inches o.c.
 - 2. Hot Rings: Attach fabric to tension lines at 24 inches o.c.
- C. Tension Bars: Extend through fabric and secure to end, corner, and pull posts with bands or clips spaced not over 15 inches o.c.
- D. Provide fabric and all bracing and framing as required to extend the fabric across the top of the animal enclosures. See drawings.

3.04 ACCESSORIES

- A. Tie Wires: Use U-shaped clip or wire, securely fastened around pipe clasping pipe and fabric firmly. Bend ends of wire to minimize sharp extensions.
- B. Fasteners: Install nuts for tension band and hardware bolts on side of fence opposite fabric side.
- C. Bolts: Used in the construction of fence shall be thoroughly peened.

3.05 CLEANING

- A. Clean work under provisions of Section 01 70 00.

END OF SECTION

THIS PAGE INTENTIONALLY LEFT BLANK

SECTION 33 10 00

WATER UTILITIES

PART 1 - GENERAL

1.1 DESCRIPTION

- A. This Section specifies requirements for the proposed water utilities including water system piping, fittings, appurtenances, and services.
- B. The work includes:
 - 1. Furnishing and installation of water distribution pipe, valves and valve boxes, hydrants, pipe fittings, anchors, thrust restraints, and required accessories and connections to existing water systems.
 - 2. Resetting existing hydrants and valve boxes to grade.
 - 3. Relocation of existing hydrants, valves, and other appurtenances as required.
 - 4. Disinfecting and testing of the water system.
- C. Work shall comply with the State of Rhode Island Plumbing Code and the Providence Water Supply Board Specifications.

1.2 RELATED SECTIONS

- A. Sections which directly relate to the work of this Section include:
 - 1. Section 31 00 00 — EARTHWORK.
 - 2. Section 03 30 55 — CAST-IN-PLACE CONCRETE(SITE).

1.3 STANDARDS

- A. AWWA — American Water Works Association
- B. NFPA — National Fire Protection Association
- C. PWSB – Providence Water Supply Board
 - 1. PWSB ‘Requirements for Water Mains, Services and Appurtenances’ (Rev 2018)

1.4 SUBMITTALS

- A. Shop Drawings
 - 1. Submit Shop Drawings or descriptive literature, or both, showing dimensions, joints, and other details of all materials to be furnished. Shop Drawings shall be submitted to the Engineer for approval prior to ordering materials.

B. As-Built Drawings

1. Submit 3 copies of As-Built Drawings upon completion and acceptance of work.
2. As-Built Drawings shall be complete and shall indicate the true measurements and locations, horizontal and vertical of all new construction. As-Built Drawings shall include a minimum of three (3) ties to each gate valve box from fixed permanent objects. As-Built Drawings shall also contain any additional information required by the municipality and shall be stamped with the seal of a licensed land surveyor and licensed professional engineer.

1.5 DELIVERY, STORAGE, AND HANDLING

- A. Storage of pipe, fittings, valves, hydrants and other water line appurtenances on the site shall be in accordance with the manufacturer's recommendations, subject to the approval of the Engineer.
- B. Care shall be taken in loading, transporting, and unloading of the water utilities materials to prevent injury to the pipe, fittings, valves, hydrants, and other water line appurtenances. Pipe, valves, or fittings shall not be dropped. All pipe or fittings shall be examined before laying and no piece shall be installed which is found to be defective. Any damage to pipe and fitting coatings shall be repaired as directed by the Engineer.
- C. Pipe, fittings, valves, hydrants, and other water system appurtenances which are defective from any cause, including damage caused by handling, and determined by the Engineer as unrepairable, shall not be used and shall be replaced at no cost to the Owner.
- D. Pipe and all water system appurtenances that are damaged or disturbed through any cause prior to acceptance of the work shall be repaired, realigned, or replaced as required by the Engineer at no additional cost to the Owner.

1.6 LICENSED FIRE PROTECTION SPRINKLER SYSTEM CONTRACTORS

- A. Fire protection and fire control systems, including both overhead and underground water mains, fire hydrants, and hydrant mains, [standpipes and hose connections to sprinkler systems, sprinkler tank heaters, back flow preventers, air lines and thermal systems, hot water fire protection systems and standpipes connected to sprinkler systems], shall be installed by contractors and personnel appropriately licensed [in the State of Rhode Island]. Shop drawings required for submittals and reviews by the Engineer, or other legally recognized professional or by applicable NFPA Standards shall note the name(s), license number(s) and license expiration date(s) of the contractor(s) installing the fire protection system.

PART 2 - PRODUCTS

2.1 GENERAL

- A. The Drawings are diagrammatic only and are intended to indicate the extent, but not all details, of the system which shall be constructed. All materials are not shown; but the Contractor shall furnish and install all materials required for the complete system.

2.2 DUCTILE IRON PIPE

- A. Ductile iron pipe shall be designed in accordance with ANSI A21.50/AWWA C150 and manufactured in accordance with ANSI A21.51/AWWA C151.
- B. Ductile iron pipe shall be Thickness Class 52 furnished in 18-foot or 20-foot nominal lengths.
- C. Pipes shall be cement-mortar lined in accordance with ANSI/AWWA C104/A21.4, except that the cement lining shall be double thickness.
- D. The exterior of all pipe shall be factory coated with a double coat of asphaltic material conforming to ANSI/AWWA C151/A21.51.
- E. Restrained joint assemblies for mechanical fittings shall be EBAA Iron Sales MEGALUG, or approved equivalent.

Restrained joint pipe shall be American Ductile Iron Pipe FLEX-RING Restrained Joint Pipe [4 inches — 12 inches, manufactured of ductile iron, all in accordance with ANSI/AWWA C151/A21.51, Pressure Rating 350 psi, or approved equivalent.

U.S. Pipe TR FLEX restrained push-on joint pipe [4 inches — 54 inches], manufactured in accordance with the requirements of ANSI/AWWA C141 A21.51, pressure class 350 for sizes 4 inches through 24 inches and pressure class 250 for sizes 30 inches through 54 inches.

U.S. Pipe FIELD LOK Gasket Instant Joint Restraint [4 inches — 24 inches], manufactured in accordance with the requirements of ANSI/AWWA C151/A21.51 for working pressure of 250 psi, or approved equivalent.

2.3 DUCTILE IRON PIPE FITTINGS

- A. All ductile iron pipe fittings shall conform to ANSI/AWWA C110/A21.10 gray and ductile iron standard fittings or ANSI/AWWA C153/A21.53-84 ductile iron compact fittings 3 inch through 16 inch. The ductile iron compact fittings shall be marked in accordance with Sec. 53-11, which states that the fittings shall have distinctly cast on them the identity of this standard, C153; the pressure rating, 350 psi; nominal diameter of openings; manufacturer's identification; the country where cast; the letters "DI" or word "Ductile"; and the number of degrees or fraction of the circle on all bends.
- B. The type of fittings for pipe and valve connections shall be determined by the Contractor in accordance with the requirements shown on the Drawings prior to ordering the fittings.
- C. All fittings shall be cement-mortar lined and coated as specified for pipe.

2.4 DUCTILE IRON PIPE COUPLINGS

- A. Couplings and accessories shall be pressure rated at least equal to that of the pipe. Couplings shall be Dresser Style 253, Smith Blair 441 Style, or approved equivalent. The couplings shall be provided with corrosion resistant nuts and bolts.

- B. Transition couplings for joining pipe of different diameters shall be Dresser Style 162, or approved equivalent. Coupling shall be provided with corrosion resistant nuts and bolts.
- C. After assembly, all exterior surfaces including the bolts and nuts shall be completely coated with two coats of a heavy-duty protective asphaltic coating. The interior of the coupling shall be epoxy-coated. Epoxy coating shall conform to AWWA C550.

2.5 DUCTILE IRON PIPE JOINTS

- A. Joints shall be either push-on or mechanical joints conforming to ANSI A21.11/AWWA C111. Push-on and mechanical joints shall be provided with required gaskets, lubricants and accessories conforming to ANSI A21.11/AWWA C111.

2.6 GATE VALVES

- A. Gate valves shall be resilient seated conforming to the requirements of AWWA C509 or AWWA C515, the type used by the municipal water department.
- B. Gate valves shall be cast iron body, bronze mounted, resilient wedge, non-rising stem with O-ring type stuffing box for valves 3 inches to 16 inches in size.
- C. Interior valve body shall have epoxy coating.
- D. Gate valves shall open to the to the left, counterclockwise, and have mechanical joints.
- E. Bolts, studs, and nuts shall be made from a corrosion-resistant material such as low-zinc bronze, nickel copper alloy, or stainless steel.
- F. Operating nut shall be 2 inches square as specified in current AWWA C509 or AWWA C515 specifications.
- G. Post indicator valves, when indicated on the drawings, are used to actuate and indicate the opened or closed status of the installed value and indicator posts. Post indicator valves shall be listed by Underwriter's Laboratories, Inc. (UL) and approved by Factory Mutual Research (FM) and shall be of a manufacturer approved by the local utility company.

2.7 VALVE BOXES

- A. Each gate valve shall be provided with a valve box and cover.
- B. Valve boxes shall be of the adjustable, telescoping, heavy-pattern type designed and constructed to prevent the direct transmission of traffic loads to the pipe or valve.
- C. Valve boxes shall be cast iron, asphalt coated with cast iron covers. The smallest inside diameter of the shaft shall not be less than 5-1/4 inches. The lower section of the box shall be designed to enclose the operating nut and stuffing box of the valve. Provisions shall be made for adjustment through at least 6-inches vertically while retaining a lap of at least 4 inches between sections.

- D. Covers shall be close fitting and substantially dirt-tight. The top of the cover shall be flush with the top of the box rim. The word WATER shall be cast in the top surface of the cover.

2.8 HYDRANTS

- A. Hydrants and their associated appurtenances shall be provided in conformance with the requirements of the Town of Narragansett Fire Department.

Hydrants shall be Model: Super Centurion 250 Fire Hydrant (Mueller Co.) or Town of Narragansett Fire Department approved equal.

- Type of Thread: National Standard
- Number of Outlets: (2) — 2-1/2-inch hose connection and (1) — 4-1/2-inch steamer connection.
- Diameter of Opening: 5 1/2 inch
- Size and Type of Inlet Connection: 6-inch mechanical joint or other [See Section 3.2.18, AWWA C502]
- Direction of Opening: Open left or right. Arrow on bonnet indicates opening direction.
- Depth of Cover: Same as required for pipe.
- Size and Shape of Operating Nut: Pentagonal [see Section 3.3.9.7, AWWA C502].

- B. Hydrant shall conform the requirements of ANSI/AWWA C502, latest issue.
- C. Bolts and nuts shall be made from a corrosion-resistant material [see AWWA C502, 3.2.17, for options].
- D. Hydrants shall be given two coats of primer paint before shipment. Contractor shall field paint hydrants the color required by the municipality, after installation.

2.9 TAPPING SLEEVE AND VALVE

- A. Tapping sleeve and valve shall meet the requirements of AWWA and shall be of the bolted- sleeve type with a mechanical joint connection to the existing water pipe and flanged end outlets for connecting the tapping valves. The tapping sleeves shall be suitable for a working water pressure of 200 psi and outlet flanges shall conform to the 125-pound American Standard with Cor-Ten or cadmium plated cast iron nuts and bolts. The tapping sleeve and valve shall be as manufactured by Mueller Company, or approved equivalent.

2.10 THRUST RESTRAINTS

- A. Thrust restraints (cement concrete thrust blocks, clamps and tie rods, and restrained joints) shall be installed in accordance with the details shown on the Drawings and per manufacturer's recommendations.
- B. Concrete for thrust blocks shall have a minimum 28-day compressive strength of 3,000 psi.

- C. Thrust blocks must be designed to withstand a minimum 1-1/2 times the anticipated working pressure of the main, but not less than 150 psi. Maximum lateral bearing capacity shall be 1500 lb/sf.

2.11 CORPORATION STOPS AND CURB STOPS

- A. Corporation stops shall be Mueller 300 ball type corporation valves or equivalent with a compression-type fitting, on the outlet end. The inlet end should be threaded per local water department requirements.
- B. Curb stops shall be Mueller 300 ball valve curb stop or approved equivalent, with compression-type fittings, on both ends.
- C. Stops shall be sized to receive the service tubing without the use of enlargement/reduction fittings.

2.12 SERVICE BOXES

- A. Service boxes shall be cast iron improved extension type with arch pattern base. Covers shall be held in place with bronze bolts and the word WATER shall be cast into the top surface of the cover. Service box shafts shall have a minimum inside diameter of 2-1/2 inches. Service boxes shall be as manufactured by Mueller Co., or approved equivalent.

2.13 WATER SERVICE

- A. Services two inches or smaller shall be ASTM B88 copper water tubing, Type K, for underground water service and shall be in accordance with ANSI/AWWA C800.
- B. Water service fittings including couplings and adapters, check valves and service saddles shall be in conformance with ANSI/AWWA C800, Underground Service Line Valves and Fittings. Joints in copper tubing shall be made with three-part compression couplings or an approved equal.
- C. Services 3 inches and greater shall be ductile iron pipe in accordance with Section 2.02 above.
- D. Services less than 3 inches that are installed with plastic pipe where the utility allows, shall be polyethylene plastic tubing, SDR 9, PE3408 rated for 200 psi at 73.4OF in accordance with ASTM D2737. The outside diameter shall be the same as copper tubing (CTS). Stainless steel inserts shall be used at all connections.

2.14 UNDERGROUND PIPE INSULATION

- A. Whenever called for on the Drawings, or required for close clearance on structures, provide factory pre-insulated piping systems.
- B. Casing pipe shall be PVC, ASTM D1784.

- C. Insulation shall be polyurethane closed-cell foam completely encapsulated on each pipe segment by a heat resistant compressed rubber seal.
- D. Manufacturer shall be Thermal Pipe Systems, 'Duc-Tite' for use with ductile iron water pipe.

PART 3 - EXECUTION

3.1 GENERAL

- A. All water pipes, fittings, valves, hydrants, and other appurtenances shall be installed at the locations as shown on the Drawings.
 - 1. The proposed location and vertical alignment may be altered to avoid conflicts with existing and proposed utilities, as approved by the Engineer.
- B. Contractor shall verify the location, size, invert and type of existing pipes at all points of connection prior to ordering new utility materials.

3.2 LAYING DUCTILE IRON PIPE AND FITTINGS

- A. Ductile iron pipe and fittings shall be installed in accordance with the requirements of ANSI/AWWA C600.
- B. Each length of pipe shall be laid with firm, full and even bearing throughout its entire length, in a trench prepared and maintained in accordance with Section 31 00 00 — EARTHWORK. The type of materials to be used in bedding and backfilling and method of placement shall conform to the requirements of Section 31 00 00 — EARTHWORK.
- C. All pipe shall be clean before laying. When laying is stopped for any reason, the open ends of the pipe shall be closed by watertight plugs or other approved means. If water is in the trench when work is resumed, the plug shall not be removed until the trench has been dewatered and all danger of water entering the pipe has been eliminated.
- D. Fittings, in addition to those shown on the Drawings, shall be provided if required to avoid utility conflicts.
- E. When cutting of pipe is required, the cutting shall be done by machine, leaving a smooth cut at right angles to the axis of the pipe. Cut ends of pipe to be used with a push-on bell shall be beveled to conform to the manufactured spigot end. Cement lining shall be undamaged.
- F. Maximum allowable deflection for pipe laid without fittings shall not exceed 75% of the allowable amount established by the pipe manufacturer and shall not exceed those shown in AWWA C600.
- G. The pipe shall be laid with a minimum cover of 5 feet below finished grade.

- H. All piping shall be laid in the dry with the spigot ends pointing in the direction of flow. Installation shall proceed from the downstream to upstream in all cases.

3.3 JOINTING DUCTILE IRON PIPE [PUSH-ON TYPE]

- A. Push-on joints shall be made in strict accordance with the manufacturer's instructions. A rubber gasket shall be inserted in the groove of the bell end of the pipe and the joint surface cleaned and lubricated using the pipe manufacturer's suggested methods and materials. The plain end of the pipe to be laid shall be inserted in alignment with the bell of the pipe to which it is to be jointed and pushed home with a jack or by other means. After joining the pipe, a metal feeler gauge shall be used to make certain that the rubber gasket is correctly located and has not been twisted or otherwise displaced.

3.4 JOINTING MECHANICAL JOINT PIPE AND FITTINGS

- A. Mechanical joints shall be made in strict accordance with the manufacturer's instructions. Mechanical joints shall be made by first cleaning the surfaces against which the gaskets will come in contact with a wire brush. The gasket, bell, and spigot shall be lubricated by washing with soapy water just prior to assembling the joint. After the nuts have been made up finger tight, the bottom nut, then top and then diametrically opposite nuts shall be progressively tightened. Bolts shall be tightened to the torques listed:

<u>Bolt Size</u> <u>(Inches)</u>	<u>Range of Torque</u> <u>(Feet-Pounds)</u>
5/8 inch	45-60
3/4 inch	75-90
1 inch	85-100

1. Under no conditions shall extension wrenches or a pipe over the handle of an ordinary ratchet wrench be used to secure greater leverage. After installation, a heavy bitumastic coating shall be applied to all bolts and nuts.
2. Restraining device shall be ductile iron and shall have dimensions such that it can be used with the standardized mechanical joint bell and tee-head bolts conforming to ANSI/AWWA A21.11 and ANSI/AWWA C153, latest revision.

3.5 CONCRETE THRUST BLOCKS

- A. Where pipes change horizontal and vertical direction, at hydrants, tees, and other fittings, and wherever abnormal thrust forces may develop, the Contractor shall construct thrust and anchor blocks as detailed on the Drawings. They shall be concrete, of minimum dimensions as

detailed on the Drawings, or of adequate additional size to suit actual conditions to withstand pressures anticipated, and shall be founded in undisturbed soil.

- B. Concrete for thrust blocks shall have a minimum 28-day compressive strength of 3,000 psi.

- C. Fittings which do not use thrust blocks resting against natural occurring material with passive resistance pressure of 1,500 psf shall be installed with a restrained joint system as specified in Article 3.07.

3.6 RESTRAINED JOINTS

- A. Pipe with restrained joints shall be installed in all areas where the pipe is within fill materials and also at locations shown on the Drawings. Restrained joints shall be installed at bends, reducers, tees, valves, dead ends, and hydrants. The minimum length of pipe to be restrained on either side of the joint shall be as shown on the table below. The fittings of the new piping shall be for restrained joints, as marked on the Drawings.

Number of Joints to Restrain on either Side of Fitting

<u>Fitting</u>	<u>Number of Joints to Restrain on Either Side of Fitting [Based on 18-Foot Pipe Length]</u>
90 degree bend	3
45 degree bend	2
22-1/2 degree bend	2
<u>Tee</u>	
Branch	3
Run	2

- B. No restraining is required in the direction of the existing pipe if only a short length of it is exposed in the trench for making a connection.
- C. Restrained joint assemblies for push-on pipe and fittings shall be made in strict accordance with the manufacturer's recommended installation procedures.
- D. Restrained joint assemblies for mechanical joint pipe shall be EBAA Iron Sales MEGALUG, or approved equivalent.

3.7 WATER/SEWER SEPARATION

- A. When a sewer pipe crosses above or below a water pipe, the Contractor shall comply with these following procedures:

1. Relation to Water Mains

- a. Horizontal Separation: Whenever possible sewers shall be laid at a minimum at least 10 feet, horizontally, from any existing or proposed water main. Should local conditions prevent a lateral separation of 10 feet, a sewer may be laid closer than 10 feet to a water main if:
 - 1) It is laid in a separate trench, or if;
 - 2) It is laid in the same trench with the water mains located at one side on a bench of undisturbed earth, and if;
 - 3) In either case, the elevations of the top (crown) of the sewer is at least 18 inches below the bottom (invert) of the water main.
- b. Vertical Separation: Whenever sewers must cross under water mains, the sewer shall be laid at such an elevation that the top of the sewer is at least 18 inches below the bottom of the water main. When the elevation of the sewer cannot be varied to meet the above requirements, the water main shall be relocated to provide this separation or reconstructed with mechanical-joint pipe for a distance of 10 feet on each side of the sewer. One full length of water main should be centered over the sewer so that both joints will be as far from the sewer as possible.
- c. When it is impossible to obtain horizontal and/or vertical separation as stipulated above, both the water main and sewer shall be constructed of mechanical-joint cement lined ductile iron pipe or other equivalent based on watertightness and structural soundness. Both pipes shall be pressure tested by an approved method to assure watertightness or both pipes shall be encased in concrete.

3.8 GATE VALVES AND BOXES

- A. Valves shall be set in firmly compacted and shaped soil. Where the soil in the trench subgrade is found to be soft, loose, freshly filled earth, unstable, or otherwise unsuitable as a base, the unsuitable material shall be excavated to such additional depth and width as required. The excavated area shall be backfilled with gravel or crushed stone, compacted, and shaped.

- B. Valve boxes shall be set centered and plumb over the operating nuts of all valves. The top of each valve box shall be set to finished grade with at least 10 inches of overlap remaining between the upper sections for vertical adjustment. Minimum overlap for lower extension pieces shall be 4 inches.
- C. Boxes shall be adequately supported during backfilling to maintain vertical alignment.

3.9 TAPPING SLEEVES AND GATE VALVES

- A. Installation shall be made under pressure and the flow of water through the existing pipe shall be maintained at all times. The diameter of the tap shall be a minimum of 1/4 inch less than the inside diameter of the branch line.
- B. The entire operation shall be conducted by workmen thoroughly experienced in the installation of tapping sleeves and valves, and under supervision of qualified personnel furnished by the manufacturer. The tapping machine shall be furnished by the Contractor.
- C. The Contractor shall determine the location of the existing pipe to be tapped to confirm that interference will not be encountered from existing utilities or a joint or a fitting. No tap shall be made closer than 3 feet from a pipe joint.
- D. Pipe upon which tapping sleeve is to be installed shall be thoroughly cleaned of all foreign matter with scraping tools and wire brushes to a minimum of six inches beyond each side of the sleeve. The cleaned area shall be washed with a hypochlorite solution. The interior of tapping valve shall also be washed with hypochlorite solution.
- E. Tapping sleeves and valves with boxes shall be set vertically and squarely centered on the pipe to be tapped. Adequate support shall be provided under the sleeve and valve during the tapping operation. Thrust blocks shall be provided behind all tapping sleeves. The supporting earth around and under the valve and sleeve shall be compacted. After completing the tap, the valve shall be flushed to ensure that the valve set is clean.
- F. Before backfilling, all exposed portions of any bolts used to hold the two halves of the sleeve together shall be heavily coated with two coats of bituminous paint equivalent to Bitumastic No. 50, by Koppers Company, Inc.

3.10 HYDRANTS

- A. Hydrants shall be installed at the locations and in conformance with the details shown on the Drawings.
- B. Each hydrant shall be set vertically and be properly braced. Hydrants shall be installed with thrust blocks or restrained joints as specified in Articles 3.05 and 3.06. Care shall be taken to ensure that thrust block concrete does not plug the hydrant's drain ports.

3.11 WATER SERVICES

- A. Service Pipe: Care shall be exercised in placing and laying of services to prevent kinks or sharp bends and to prevent contact with sharp stones or ledge which would damage to the pipe. At least 6 inches of sand shall be placed adjacent to, under, and above the pipe, and no stone larger than 2 inches shall be placed over the pipe until the depth of backfill above the pipe is in excess of 1 foot.
- B. Corporation Stop: Taps to the pipe shall be threaded and shall be made at the horizontal diameter of the main. The tap shall be made by means of a tapping machine manufactured for this purpose and supplied by the Contractor. The tap and drill shall be kept sharp and shall have threads matching those of the stop. Corporation stop threads shall be coated with sealing compound and the stop screwed firmly into the water with the key upward and the inlet end projecting at least 1/8 inch beyond the inside face of the pipe. Corporation stop shall be left in the on open position after installation of the service pipe.
- C. Curb Stop and Curb Boxes: Curb stop and curb boxes shall be of a size equal to the size of the service pipe and shall be installed in the locations shown on the Drawings or as ordered by the Engineer. The boxes shall be set in a vertical position and flush with the proposed finish grade.
- D. Ductile Iron Service Pipe: Ductile iron service pipe connections to the water pipe shall be made with tee fittings or tapping sleeves. [Engineer Note: Review availability of tees, reducers, etc. in order to ensure feasibility of connection for lower size (smaller diameter) ductile iron services.]

3.12 SEPARATION FROM STRUCTURES

- A. Whenever possible, water pipes shall maintain a minimum distance of three (3) feet from underground adjacent unheated structures, such as manholes, catch basins, retaining walls, bridge abutments, parking garages, etc.
- B. When spacing under 3.13A. above is not possible, Contractor shall provide insulated water pipe for a minimum of three (3) feet beyond the limits of the adjacent structure.

3.13 PRESSURE TESTING

- A. Hydrostatic and leakage test shall be conducted in accordance with AWWA Standard C600, and NFPA 24, Standards, except it shall meet the leakage rates stated in 3.15D. below as directed by the Engineer. Testing shall be conducted by a certified independent water testing company.
- B. Conduct pipe tests after concrete thrust blocks have cured to the required minimum 28-day compressive strength of 3,000 psi. Fill pipe 24 hours prior to testing, and apply test pressure to stabilize system. Use only potable water.
- C. Prior to pressure testing, the entire pipe section shall be flushed to remove any rocks or debris which may have inadvertently entered the pipe during construction.

- D. Once the pipe section has been filled at normal pressure and all entrapped air removed, the Contractor shall raise the pressure to 200 psi or two times the operating pressure (whichever is greater) by a special pressure pump, taking water from a small tank of proper dimensions for satisfactorily measuring the rate of water pumped into the pipe. This pressure shall be maintained for a minimum of two hours, during which time the line shall be checked for leaks. Measured rate of water leakage shall not exceed the allowable leakage as follows:
1. Domestic water service pipes only, without attached fire service supply: Meet latest edition of AWWA C600 series leakage requirements for the type of pipe being installed.
 2. Fire protection piping and domestic water service pipe with attached fire service piping: Meet latest edition of NFPA 24 leakage requirements or latest edition of AWWA C600 series leakage requirements for the type of pipe being installed, whichever criteria is more stringent.
 3. Interior piping in vaults, buildings, etc. shall have zero leakage.
 4. Should leakage exceed the above rates, the Contractor shall immediately locate the leak or leaks and repair them. Pipe will be accepted only when leakage is zero, or less than the allowable amount. Approval does not absolve the Contractor from responsibility if leaks develop later within the period of warranty.

3.14 DISINFECTION

- A. Before being placed in service, all new water pipe shall be chlorinated in accordance with ANSI/AWWA C651 Standard for Disinfecting Water Mains. University authorized representative shall be present during the chlorination process and witness the sampling procedure for bacteriological testing.
- B. The location of the chlorination and sampling points will be determined by the Engineer in the field. Taps for chlorination and sampling shall be installed by the Contractor. The Contractor shall uncover and backfill the taps as required.
- C. The pipe section being disinfected shall be flushed to remove discolored water and sediment from the pipe. A 25 mg/I chlorine solution in approved dosages shall be inserted through a tap at one end while water is being withdrawn at the other end of the pipe section. The chlorine concentration in the water in the pipe shall be maintained at a minimum 25 mg/I available chlorine during filling. To assure that this concentration is maintained, the chlorine residual shall be measured at regular intervals in accordance with procedures described in Standard Methods and AWWA M12, Simplified Procedure for Water Examination, Section K.
- D. During the application of the chlorine, valves shall be manipulated to prevent the treatment dosage from flowing back into the pipe supplying the water. Chlorine application shall not cease until the entire pipe section is filled with chlorine solution. The chlorinated water shall be retained in the pipe for at least a twenty-four-hour period. The treated water shall contain a chlorine residual throughout the length of the pipe section as indicated in AWWA C651.

- E. Following the chlorination period, all treated water shall be flushed from the pipe section and replaced with water from the distribution system. Prior to disposal of treated water, the Contractor shall check with local authorities to determine if the discharge will cause damage to the receiving body or sewer and, if required, the Contractor shall neutralize the chlorinated water in accordance with Appendix B, AWWA C650. Bacteriological sampling and analysis of the replacement water shall then be made by the Contractor in full accordance with AWWA Specification C651. A minimum of three samples shall be taken by the Contractor at locations directed by the Engineer along the length of water pipe being chlorinated and sent to a state- approved private laboratory for analyses. The Contractor shall re-chlorine if the samples show presence of coliform, and the pipe section shall not be placed in service until all of the repeat samples show no presence of coliform.
- F. Furnish two (2) copies of a Certificate of Disinfection Report to the Engineer.
- G. The Contractor shall pay all costs for all testing, flushing, chlorinating, laboratory analyses, sampling, water supply, and municipal charges.

END OF SECTION 33 10 00

SECTION 33 39 00

SANITARY SEWERAGE UTILITY STRUCTURES

PART 1 - GENERAL

1.1 DESCRIPTION

- A. This Section specifies requirements for sanitary utility sewerage structures for a gravity flow sewerage system.
- B. The work includes furnishing and installing all pipe, fittings manholes, structures and appurtenances required for the proposed system to convey sewage by gravity flow conditions.
- C. Work and materials shall be performed in accordance with the State Plumbing Code. Work within 10 feet of the building or those dedicated systems within the site shall conform to the Rhode Island State Plumbing Code.
- D. Work and materials shall be performed in accordance with City of Providence Standard Details <http://www.providenceri.gov/wp-content/uploads/2019/06/Providence-DPW-Standard-Details.pdf>

1.2 RELATED SECTIONS

- A. Sections which directly relate to the work of this Section include:
 - 1. Section 03 30 55 — CAST-IN-PLACE CONCRETE (SITE).
 - 2. Section 31 00 00 — EARTHWORK.
 - 3. Section 33 40 00 - STORM DRAINAGE UTILITIES.

1.3 SUBMITTALS

- A. Materials List and Shop Drawings
 - 1. Materials list of materials proposed.
 - 2. Shop drawings for all material and structures prior to ordering materials.
- B. As-Built Drawings
 - 1. Submit [three (3)] copies of As-Built Drawings upon completion and acceptance of work.
 - 2. As-Built Drawings shall be complete and shall indicate the true measurement and location, horizontal and vertical, of all new construction. As-Built Drawings shall include a minimum of three (3) ties to each manhole from fixed permanent objects. As-Built Drawings shall also contain any additional information required by the municipality and shall be stamped with the seal of a licensed land surveyor and licensed professional engineer.

1.4 INSPECTION

- A. The manufacturer/supplier is responsible for the provisions and all test requirements specified in ASTM D3034 for SDR 35 gravity pipe and ASTM D2241 for PVC pressure rated sewer pipe. In addition, all PVC pipe may be inspected at the plant for compliance with these specifications by an independent testing laboratory selected and paid by the Owner. The Contractor shall require the manufacturer's cooperation in these inspections.
- B. Inspection of the pipe may also be made after delivery. The pipe shall be subject to rejection at any time on account of failure to meet any of the specification requirements, even though pipe samples may have been accepted as satisfactory at the place of manufacture. Pipe rejected after delivery shall be marked for identification and shall be removed from the site at once.

1.5 DELIVERY, STORAGE, AND HANDLING

- A. All materials shall be adequately protected from damage during transit. Pipes shall not be dropped.
- B. All pipe and other appurtenances shall be inspected before placement in the work and any found to be defective from any cause, including damage caused by handling, and determined by the Engineer to be unrepairable, shall be replaced at no cost to the Owner.
- C. Storage and handling of pipes, manholes and other sewer system appurtenances shall be in accordance with the manufacturer's recommendations, subject to the approval of the Engineer.

PART 2 - PRODUCTS

2.1 POLYVINYL CHLORIDE PIPE (PVC)

- A. Pipe and Fittings: Polyvinyl chloride pipe and fittings (4 inches to 15 inches) shall be Type PSM polyvinyl chloride (PVC) SDR [35,26 or other] with full diameter dimensions conforming to the specifications for Type PSM Polyvinyl Chloride (PVC) Sewer Pipe and Fittings, ASTM D3034.
- B. Joints: PVC pipe shall have an integral wall bell and spigot push-on joint with elastomeric gaskets secured in place in the bell of the pipe. The bell shall consist of an integral wall section with a solid cross section elastomeric gasket, factory assembled, securely locked in place to prevent displacement during assembly. Elastomeric gaskets shall conform to ASTM D3212.
- C. Spigot pipe ends shall be supplied with bevels from the manufacturer to ensure proper insertion. Each spigot end shall have an "assembly stripe" imprinted thereon to which the bell end of the mated pipe will extend upon proper joining of the two pipes.

2.2 MANHOLES

A. Precast Concrete Units:

1. Structure: 4-foot minimum inside diameter precast concrete units (4,000 psi minimum compressive strength) with eccentric cone section tapering to 30-inch diameter, or flat top, and one pour monolithic base section conforming to ASTM C478. All units to be designed for HS-20 loading.
2. Precast Unit Joint: Preformed Butyl rubber section joint conforming to ASTM C443.
3. The date of manufacture and the name or trademark of the manufacturer shall be clearly marked on the inside of each precast section.

B. Masonry Units:

1. Brick shall conform to ASTM C32, Grade SM for construction of inverts and adjusting manholes to grade.
2. Concrete block shall be solid block and conforming to ASTM C139.
3. Mortar shall be in conformance with ASTM C270, Type M. The mortar shall be composed of Portland cement hydrated lime, and sand, in the proportions of 1 part cement to 1/4 part hydrated lime, to 3-1/2 parts sand, by volume.
4. Cement shall be Type I or II Portland cement conforming to ASTM C150. Where masonry is exposed to salt water, Type II shall be used.
5. Hydrated lime shall be Type S conforming to ASTM C207.
6. Sand for masonry mortar shall conform to the gradation requirements of ASTM C144.

C. Manhole Frame and Cover: Grey iron casting conforming to ASTM A48, heavy duty, with the word SEWER embossed on cover. Letter size shall be three inches. Frame and cover shall be East Jordan Iron Works 2008Z/2006A or approved equivalent, with a minimum clear opening of 30 inches. Use 3,000 psi concrete to secure frame to manhole or catch basin.

D. Pipe Connections: Flexible sleeve or rubber gaskets shall be Lock Joint, Kor-n-Seal, A-Lok or approved equivalent.

E. Steps: Steps for steel reinforced copolymer polypropylene step with at least a 14-inch-wide stepping surface conforming to ASTM C478.

2.3 BITUMASTIC COATINGS

- A. The entire exterior surface of all masonry and concrete (whether precast or cast-in-place) structures associated with sewerage systems, such as manholes, grease traps, holding tanks, tight tanks, septic tanks, aeration tanks, pump stations, valve pits, etc., shall receive two coats of waterproofing such as Carboline Bitumastic 300M as manufactured by Carboline Company, St. Louis, MO 63144-1599, Sonoshield HLM 5000 as manufactured by Degussa Building Systems, Shakopee, MN 55379, applied at a minimum thickness of 7 mils per coat and a total thickness of 14 mils, however in no case shall the thickness per coat be less than that recommended by the manufacturer.

PART 3 - EXECUTION

3.1 EXCAVATION AND BACKFILLING

- A. The type of materials to be used in bedding and backfilling and the method of placement shall conform to the requirements of Section 31 00 00, EARTHWORK and the details shown on the Drawings.

3.2 PIPE INSTALLATION

- A. All sewer pipe shall be laid accurately to the lines and grades shown in the Drawings and in conformance with pipe manufacturer's recommended procedures.
- B. Notch under pipe bells and joints, where applicable, to provide for uniform bearing under entire length of pipe.
- C. Laying Pipe: Each length of pipe shall be laid with firm, full and even bearing throughout its entire length, in a prepared trench. Pipe shall be laid with bells up grade unless otherwise approved by the Engineer. Do not permanently support pipes on bells.
 - 1. Every length of pipe shall be inspected and cleaned of all dirt and debris before being laid. The interior of the pipe and the jointing seal shall be free from sand, dirt and trash. Extreme care shall be taken to keep the bells of the pipe free from dirt and rocks so that joints may be properly lubricated and assembled. No pipe shall be trimmed or chipped to fit.
 - 2. No length of pipe shall be laid until the preceding lengths of pipe have been thoroughly embedded in place, to prevent movement or disturbance of the pipe alignment.
 - 3. All piping shall be laid in the dry with the spigot ends pointing in the direction of flow. Installation shall proceed from the downstream to upstream in all cases.
- D. Pipe Extension: Where an existing pipe is to be extended, the same type of pipe shall be used, unless otherwise approved by the Engineer.
- E. Full Lengths of Pipe: Only full lengths of pipe shall be used in the installation except that partial lengths of pipe may be used at the entrance to structures, and to accommodate the required locations of service connection fittings.
- F. Pipe Entrances to Structures: All pipe entering structures shall be cut flush with the inside face of the structure, and the cut ends of the pipe surface within the structure shall be properly rounded and finished so that there will be no protrusion, ragged edges, or imperfections that will impede or affect the hydraulic characteristics of the sewage flow. The method of cutting and finishing shall be subject to the approval of the Engineer.
- G. Protection During Construction: The Contractor shall protect the installation at all times during construction, and movement of construction equipment, vehicles and loads over and adjacent to any pipe shall be performed at the Contractor's risk.

1. At all times when pipe laying is not in progress, all open ends of pipes shall be closed by approved temporary water-tight plugs. If water is in the trench when work is resumed, the plug shall not be removed until the trench has been dewatered and all danger of water entering the pipe has been eliminated.

H. Water Pipe - Sewer Pipe Separation: When a sewer pipe crosses above or below a water pipe, the Contractor shall comply with the following procedures:

1. Relation to Water Mains

- a. Horizontal Separation: Whenever possible sewers shall be laid at a minimum at least 10 feet, horizontally, from any existing or proposed water main. Should local conditions prevent a lateral separation of 10 feet, a sewer may be laid closer than 10 feet to a water main if:
 - 1) it is laid in a separate trench, or if
 - 2) it is laid in the same trench with the water mains located at one side on a bench of undistributed earth, and if
 - 3) in either case the elevation of the top (crown) of the sewer is at least 18 inches below the bottom (invert) of the water main.
- b. Vertical Separation: Whenever sewers must cross under water mains, the sewer shall be laid at such an elevation that the top of the sewer is at least 18 inches below the bottom of the water main. When the elevation of the sewer cannot be varied to meet the above requirements, the water main shall be relocated to provide this separation or reconstructed with mechanical-joint pipe for a distance of 10 feet on each side of the sewer. One full length of water main should be centered over the sewer so that both joints will be as far from the sewer as possible.
- c. When it is impossible to obtain horizontal and/or vertical separation as stipulated above, both the water main and sewer shall be constructed of mechanical-joint cement lined ductile iron pipe or other equivalent based on watertightness and structural soundness. Both pipes shall be pressure tested by an approved method to assure watertightness or both pipes shall be encased in concrete.

I. Sewer Pipes-Laser Installation: Sewer pipes shall be laid to required grades by use of a laser and target system, unless otherwise specifically approved in writing by Engineer.

3.3 PIPE JOINTS

A. All joints shall be made water-tight.

B. Pipe shall be jointed in strict accordance with the pipe manufacturer's instruction. Jointing of all pipe shall be done entirely in the trench.

1. Lubricant for jointing of PVC pipe shall be applied as specified by the pipe manufacturer. Use only lubricant supplied by the pipe manufacturer.
2. PVC pipe shall be pushed home by hand or with the use of bar and block. The use of power equipment, such as a backhoe bucket, shall only be used at the direction of the manufacturer.
3. Field-cut pipe ends shall be cut square and the pipe surface beveled to the size and shape

of a factory-finished beveled end. All sharp edges shall be rounded off.

- C. Jointing of ductile iron shall be in accordance with Section 331000, WATER UTILITIES.

3.4 MANHOLES

- A. General Requirements: All manholes shall be built in accordance with the Details and in the locations shown on the Drawings.
1. Structures shall be constructed of brick masonry, precast solid concrete block, cast-in-place concrete, or precast concrete.
 2. All masonry shall be installed by personnel experienced and skilled in this work, and any person not deemed to be such by the Engineer shall be removed and replaced by a person so qualified.
 3. Manholes shall be constructed as soon as the pipe laying reaches the location of the manhole. Should the Contractor continue pipe laying without making provision for completion of the manhole, the Engineer shall have the authority to stop the pipe laying operations until the manhole is completed.
 4. The Contractor shall accurately locate each manhole and set accurate templates to conform to the required line and grade. Any manhole which is mislocated or oriented improperly shall be removed and rebuilt in its proper location, alignment, and orientation at no additional cost to the Owner.
- B. Foundations: All manholes shall be constructed on a 12-inch layer of compacted bedding material. The excavation shall be dewatered to provide a dry condition while placing bedding material and setting the base.
- C. Masonry: All brick or concrete block shall be thoroughly wetted before laying.
1. The first course of masonry shall be embedded in the concrete foundation immediately after the foundation has been poured.
 2. All masonry shall be laid in the flat position in a full bed of mortar, and all vertical and horizontal joints shall be filled solid with mortar. Vertical joints on each succeeding course shall be staggered. Joints shall be not less than 3/8-inch-wide or more than 1/2 inch wide. Joints on the inside of the structure shall be neatly struck and pointed.
 3. The exterior and interior surface of the walls shall be plastered with a one-half inch (1/2 in.) coat of 1:2 cement mortar.
- D. Invert: Brick invert channels shall be constructed in all manholes to provide a smooth channel for sewage flow through the structure and shall correspond in shape to the lower half of the pipe. At changes in directions, the inverts shall be laid out in curves of the longest possible radii tangent to the centerline of the sewer pipes at the manhole side. Shelves shall be constructed to the elevation of the highest pipe crown and sloped to drain toward the flow channel.

1. Special care shall be taken in laying brick inverts. Joints shall not exceed three-sixteenth inch (3/16 in.) in thickness and each brick shall be carefully laid in full cement mortar joints on bottom, side and end in one operation. No grouting or working in of mortar after laying of the brick will be permitted. Bricks forming the shaped inverts in manholes shall be laid on edge.
 2. Invert channels shall be built for future extensions where shown on the Drawings and where directed by the Engineer.
- E. Steps: Steps shall be installed in all manholes, spaced twelve inches (12 in.) on center vertically and set securely in place during the construction of the masonry wall. Precast sections shall be arranged such that internal steps are in alignment.
- F. Precast Manholes: Precast manholes shall be installed only after shop drawings have been approved.
1. The top grade of the precast concrete cone section shall be set sufficiently below finished grade to permit a maximum of five and a minimum of two courses (laid in the flat position) of eight-inch (8 in.) brick to be used as risers to adjust the grade of the manhole frame. Manhole frames shall be set on a grout pad to make a water-tight fit.
 2. Grout fill lifting holes on all manhole sections.

3.5 CONNECTIONS TO EXISTING FACILITIES

- A. General Requirements: The Contractor shall make all required connections of the proposed sewer into existing sewer system, where and as shown on the Drawings and as required by the Engineer.
- B. Contractor shall verify the location, size, invert and type of existing pipes at all points of connection prior to ordering new utility materials.
- C. Compliance with Requirements of Owner of Facility: Connections into existing sewer facilities shall be performed in accordance with the requirements of the owner of the facility. The Contractor shall comply with all such requirements, including securing of all required permits, and paying the costs thereof. The costs of making the connections in accordance with the requirements of the owner of the existing facility shall be included in the Contract Sum.

3.6 MANHOLE CONNECTIONS

- A. Manhole pipe connections for precast manhole bases may be accomplished by any method described below. The Contractor shall make sure that the outside diameter of the pipe is compatible with the particular pipe connection used.
1. A tapered hole filled with non-shrink waterproof grout after the pipe is inserted. This connection method will not be allowed when connecting PVC pipe to manholes.
 2. The LOCK JOINT Flexible Manhole Sleeve cast in the wall of the manhole base. The stainless-steel strap and exposed sleeve shall be protected from corrosion with a bitumastic coating.

3. PRESS WEDGE II gasket cast into the wall on the manhole base. The rubber wedge shall only be driven into the V slot from the outside of the manhole.
4. The RES-SEAL, a cast iron compression ring which compresses a rubber "O" ring gasket into a tapered hole in the wall of the manhole base. Exposed metal shall be protected from corrosion with a bitumastic coating.
5. KOR-N-SEAL neoprene boot cast into the manhole wall. The stainless-steel clamp shall be protected from corrosion with a bitumastic coating.

- B. Sewer manholes shall be constructed with drop connections when the proposed invert of the connection is at least 2 feet (2 ft.) above the manhole invert. Drop connections for differences of less than 2 feet (2 ft.) shall also be provided if required by the governing authority.

3.7 SERVICE CONNECTIONS

- A. General Requirements: The Contractor shall make all required connections of the building sewer service pipes into the sewer system. Work shall include making the service pipe connections into the sewer system pipes or into the manholes located ten feet (10 ft.) outside of the proposed building lines. If stubs are constructed for later connection to the building pipes, the ends shall be sealed with watertight plugs.
- B. Coordination with Building Contractor: The Contractor shall coordinate the work with the work of the building contractor to determine the exact location and elevation of the point of entry into the building.
- C. Connection into Sewer System: Sewer service pipe connections to the pipe of the sewer system shall be made with fittings supplied by the pipe manufacturer.
1. The Contractor shall install 45-degree wye branch or 90-degree tee fittings in the sewer pipes at all locations where building sewer service pipe connections are shown on the Drawings. Connections of the sewer service pipes shall be made into the wye branches or tees by means of 45-degree bends. The connections shall be made thoroughly watertight and concrete shall be placed under each connection to bear on undisturbed earth and firmly support the connection. Sewer chimneys shall be encased in concrete unless directed otherwise by the Engineer.

3.8 LEAKAGE TESTS

- A. General Requirements: The Contractor shall test the completed sewer system, including manholes and service connections, for leakage by infiltration, exfiltration, or low-pressure air exfiltration tests. Manhole structures may be tested by a low-pressure air vacuum test. The tests shall be conducted as approved by the Engineer. The Contractor shall furnish all necessary equipment, materials and labor for performing the tests.
1. The Contractor shall notify the Engineer at least 48 hours prior to the start of testing. Testing shall only be performed in the presence of the Engineer.
 2. Sections of pipe tested for infiltration and exfiltration prior to completion of the Contract shall be subject to additional leakage tests, if warranted, in the opinion of the Engineer, prior to acceptance of the Work.
- B. Infiltration and Exfiltration Testing: The test length intervals for either type of leakage test shall

be approved by the Engineer, but in no event shall they exceed one thousand feet (1,000 ft.). Where sewer pipe is laid on steep grades, the length to be tested by exfiltration at any one time shall be limited by the maximum allowable internal pressure on the pipe and joints at the lower end of the line. The maximum internal pressure at the lowest end shall not exceed 25 feet of water or 10.8 psi.

1. The test period, wherein the measurements are taken, shall not be less than four (4) hours in either type of test.
2. Depending on field conditions, the following tests for leakage shall be employed:
 - a. Infiltration Test: The test may be used only when ground water levels are at least five feet (5 ft.) above the top of the pipe for the entire length of the section to be tested during the entire period of the test. Ground water levels may be measured in an open trench or in standpipes previously placed in backfilled trenches during the backfilling operations. When standpipes are installed in the backfill for ground water measurement, the lower ends shall be satisfactorily embedded in a mass of crushed stone or gravel to maintain free percolation and drainage. Infiltration through joints shall be measured by using a watertight weir or any other approved device for volumetric measurement installed at the lower end of the section under test.
 - b. Exfiltration Test: This test consists of filling the pipe with water to provide a head of at least five feet (5 ft.) above the top of the pipe or five feet (5 ft.) above ground water, whichever is higher, at the highest point of the pipe section under test, and then measuring the loss of water from the line by the amount which must be added to maintain the original level. In this test, the pipe must remain filled with water for at least twenty-four (24) hours prior to the taking of measurements. Exfiltration shall be measured by the drop of water level in a closed-end standpipe or in one of the sewer manholes available for convenient measuring. When a standpipe and plug arrangement is used in the upper manhole of a section under test, a positive method of releasing entrapped air in the sewer shall be installed prior to taking measurements.
 - c. Leakage Requirements: The total leakage of any section tested shall not exceed the rate of 50 gallons per day per mile per inch of nominal pipe diameter. For purposes of determining the maximum allowable leakage, manholes shall be considered as sections of 48-inch diameter pipe, five feet (5 ft.) long, and the equivalent leakage allowance shall be 2.25 gallons per manhole per 24 hours.

C. Low-Pressure Air Exfiltration Testing

1. The sewer pipes and service pipes shall be tested for leakage by the use of low-pressure air as approved by the Engineer. The test length shall not exceed one length of pipe between two manholes. Air test procedures may be dangerous and the Contractor shall take all necessary precautions to prevent blowouts.
 - a. Pneumatic plugs shall have a sealing length equal to or greater than the diameter of the pipe to be tested.
 - b. Pneumatic plugs shall resist internal test pressures without requiring external bracing or blocking.
 - c. All air used shall pass through a single control panel.
 - d. Three individual hoses shall be used for the following connections:
 - 1) from control panel to pneumatic plugs for inflation;

- 2) from control panel to sealed line for introducing the low-pressure air;
 - 3) from sealed line to control panel for continually monitoring the air pressure rise in the sealed line.
2. The following testing procedures shall be explicitly followed:
- a. All pneumatic plugs shall be seal tested before being used in the actual test installation. One length of pipe shall be laid on the ground and sealed at both ends with the pneumatic plugs to be checked. Air shall be introduced into the plugs to 25 psig. The sealed pipe shall be pressurized to 5 psig. The plugs shall hold against this pressure without bracing and without movement of the plugs out of the pipe.
3. After the pipe has been backfilled and cleaned, pneumatic plugs shall be placed in the line at each manhole and inflated to 25 psi. Low-pressure air shall be introduced into this sealed line until the internal air pressure reaches 4 psi greater than the average back pressure of any ground water that may be over the pipe. At least two (2) minutes shall be allowed for the air pressure to stabilize.
- a. After the stabilization period (3.5 psi minimum pressure in the pipe), the portion of pipe tested shall be acceptable if the time required in minutes for the pressure to decrease from 3.5 to 3.0 psi (greater than the average back pressure of any ground water that may be over the pipe) is not less than the time indicated in the following table:

Where L = length of pipe being tested

<u>Pipe Size (in.)</u>	<u>Time (sec.)</u>
4	0.190L
6	0.427L
8	0.760L
10	1.187L
12	1.709L
15	2.671L

- D. Vacuum Testing of Manholes: New sewer manholes shall be vacuum tested in accordance with procedure and standards in ASTM C1244.
- E. Correction of Defective Work: If leakage exceeds the specified amount, the Contractor shall make the necessary repairs or replacements required to permanently reduce the leakage to within the specified limit, and the tests shall be repeated until the leakage requirement is met.
- F. Compliance with Agency Requirements: In the event of conflict between the leakage test requirements specified herein with the leakage test requirements of agencies having jurisdiction over all or any portion of the sewer system installed under this Contract, the more restrictive requirements shall govern.

3.9 PIPE DEFLECTION MEASUREMENT

- A. In accordance with ASTM D3034, no less than 30 days after completion of the PVC sewer pipe installation, the Contractor shall test the pipeline for deflection using a 'go/no-go' deflection mandrel having a minimum of nine evenly spaced arms or prongs. The 'go/no-go' gauge shall be hand pulled through all sections of the pipeline by the Contractor. The Contractor shall submit drawings of the 'go/no-go' gauge to the Engineer for approval prior to testing. Complete dimensions of the gauge for each diameter of pipe to be tested shall be in accordance with ASTM D3034.
- B. Any section of pipe found to exceed 7.5 percent (7.5%) deflection shall be deemed a failed pipe and shall be excavated and replaced by the Contractor at his own expense.

3.10 CLEANING AND REPAIR

- A. The Contractor shall clean the entire sewer system of all debris and obstructions. This shall include removal of all formwork from structures, concrete and mortar droppings, construction debris and dirt. The system shall be thoroughly flushed clean and the Contractor shall furnish all necessary hose, pumps, pipe and other equipment that may be required for this purpose. No debris shall be flushed into existing sewers, storm drains, and or streams.
- B. All work of cleaning and repair shall be performed at no additional cost to the Owner

3.11 FINAL INSPECTION

- A. Upon completion of the work, and before final acceptance by the Engineer, the entire sewer system shall be subjected to a final inspection in the presence of the Engineer. The work shall not be considered as complete until all requirements for line, grade, cleanliness, leakage tests and other requirements have been met.

END OF SECTION 33 39 00

THIS PAGE INTENTIONALLY LEFT BLANK

SECTION 33 40 00

STORM DRAINAGE UTILITIES

PART 1 - GENERAL

1.1 DESCRIPTION

- A. This Section specifies requirements for furnishing and installing the site storm drainage utilities system, as indicated on the Drawings and as specified herein.
- B. The work shall include but not be limited to the following:
 - 1. Site storm drainage system.
 - 2. Connection of building drains from a point five feet (5 ft.) outside of the building or structure foundation.
 - 3. Site underdrains and flared end sections.

1.2 RELATED SECTIONS

- A. Carefully examine all of the Contract Documents for requirements which affect the Work in this Section. Other specification sections, which directly relate to the Work of this section include, but are not limited to, the following:
 - 1. Section 01 89 00 - SITE CONSTRUCTION PERFORMANCE REQUIREMENTS
 - 2. Section 03 30 55 - CAST-IN-PLACE CONCRETE (SITE)
 - 3. Section 31 25 00 - EROSION AND SEDIMENTATION CONTROL
 - 4. Section 31 00 00 - EARTHWORK
 - 5. Section 33 10 00 - WATER UTILITIES
 - 6. Section 33 39 00 - SANITARY UTILITY SEWERAGE STRUCTURES

1.3 REFERENCE STANDARDS

- A. References herein are made to the following Standards:
 - 1. American Society for Testing and Materials (ASTM):
 - A48 Standard Specification for Gray Iron Castings
 - A615 Standard Specification for Deformed and Plain Carbon-Steel Bars for Concrete Reinforcement
 - C32 Standard Specification for Sewer and Manhole Brick
 - C39 Standard Test Method for Compressive Strength of Cylindrical Concrete Specimens

- C62 Standard Specification for Building Brick
- C76 Standard Specification for Reinforced Concrete Culvert, Storm Drain, and Sewer Pipe
- C139 Standard Specification for Concrete Masonry Units for Construction of Catch Basins and Manholes
- C144 Standard Specification for Aggregate for Masonry Mortar
- C150 Standard Specification for Portland Cement
- C207 Standard Specification for Hydrated Lime for Masonry Purposes
- C270 Standard Specification for Mortar for Unit Masonry
- C443 Standard Specification for Joints for Concrete Pipe and Manholes, Using Rubber Gaskets
- C478 Standard Specification for Circular Precast Reinforced Concrete Manhole Sections
- C990 Standard Specification for Joints for Concrete Pipe, Manholes, and Precast Box Sections Using Preformed Flexible Joint Sealants
- D2665 Standard Specification for Poly(Vinyl Chloride) (PVC) Plastic Drain, Waste, and Vent Pipe and Fittings
- D3034 Standard Specification for Type PSM Poly(Vinyl Chloride) (PVC) Sewer Pipe and Fittings
- D3350 Standard Specification for Polyethylene Plastics Pipe and Fittings Materials
- D4884 Standard Test Method for Strength of Sewn or Bonded Seams of Geotextiles
- F477 Standard Specification for Elastomeric Seals (Gaskets) for Joining Plastic Pipe
- F667 Standard Specification for 3 through 24 in. Corrugated Polyethylene Pipe and Fittings
- F2418 Standard Specification for Polypropylene (PP) Corrugated Wall Stormwater Collection Chambers

1.4 SUBMITTALS

A. Shop Drawings

1. Shop drawings or descriptive literature, or both, showing dimensions, joint and other details of all materials proposed for the work. Shop drawings shall be submitted to the Engineer for approval prior to ordering material.

B. As-Built Drawings

1. The Contractor shall take measurements during construction of:
 - a. Horizontal location of all drainage structures. Horizontal location shall be by survey location using the same coordinate system as the Project, or three (3) (minimum) ties to nearby permanent structures.
 - b. Elevations of all inverts using Project Benchmarks.
2. As-Built Drawings shall be submitted to the Engineer upon completion of the work.
3. As-Built Drawings shall be complete and shall indicate the true measurement and location, horizontal and vertical, of all new drainage system construction. As-Built drawings shall include a minimum of three (3) ties showing the distance to each catch basin and manhole from fixed permanent objects. As-Built Drawings shall also contain any additional information required by the municipality and shall be stamped with the seal of a licensed Land Surveyor or licensed Professional Engineer.

1.5 QUALITY ASSURANCE

- A. Work shall comply with the State of Rhode Island Plumbing Code.

1.6 COORDINATION AND VERIFICATION

- A. Coordinate the work with the termination of storm drain connections at buildings, connections to municipal systems, and trenching operations.
- B. The Contractor shall field verify and survey the size, location and elevations of all existing pipe and utility lines prior to ordering of materials for this utility system. A report of the findings of the verification survey shall be submitted to the Engineer for information and comment.

1.7 DELIVERY, STORAGE, AND HANDLING

- A. All materials shall be adequately protected from damage during transit. Pipes shall not be dropped.
- B. All pipe and other appurtenances shall be inspected before placement in the work and any found to be defective from any cause, including damage caused by handling, and determined by the Engineer to be unrepairable, shall be replaced at no cost to the Owner.
- C. Storage and handling of pipes, manholes, catch basins, oil-grit separators, treatment units and other system appurtenances shall be in accordance with the manufacturer's recommendations.

1.8 INSPECTION

- A. The manufacturer/supplier is responsible for the provision of all test requirements specified for each type of pipe. In addition, any pipe may be inspected at the plant for compliance with these specifications by an independent testing laboratory selected and paid by the Owner. The Contractor shall require the manufacturer's cooperation in these inspections.
- B. Inspection of the pipe may also be made after delivery. The pipe shall be subject to rejection at any time on account of failure to meet any of the specification requirements, even though pipe samples may have been accepted as satisfactory at the place of manufacture. Pipe rejected after delivery shall be marked for identification and shall be removed from the site at once.

PART 2 - PRODUCTS

2.1 GENERAL

- A. All materials for storm drainage utilities system shall be new and unused.

2.2 REINFORCED CONCRETE PIPE:

- A. Pipe shall comply with the requirements of ASTM C76. All pipe 18 inches and smaller shall be Class V. All other pipe shall be Class III unless indicated otherwise on the drawings.
 - 1. Joints for the reinforced concrete pipe shall be the tongue and groove or bell and spigot type with rubber gasket conforming to ASTM C443.
 - 2. Flared end pipe sections shall be constructed in conformance with ASTM C76, Class V requirements and shall be supplied by the same manufacturer as the pipe.

2.2 FILTER FABRIC

- A. Filter Fabric for Underdrains shall be Mirafi 140N or approved equivalent.
- B. Filter Fabric for Flared End Sections and Headwalls with Stone Protection shall be Mirafi 600X, or approved equivalent.

2.3 HIGH DENSITY CORRUGATED POLYETHYLENE (HDPE) PIPE

- A. HDPE pipe and fittings shall be smooth interior, and meet the requirements of ASTM D3350. Four-inch through 10-inch diameter HDPE pipe shall meet the requirements of AASHTO M 252. Twelve-inch through 60-inch diameter HDPE pipe shall meet the requirements of AASHTO M 294, Types S.
- B. Standard Fitting connections shall be fabricated to sizes shown on the Drawings.
- C. Pipe joints and fittings shall conform to the requirements of AASHTO M 252 or AASHTO M 294. Pipe joints shall be Bell and Spigot soil tight joints and gaskets shall meet the requirements of ASTM F477. Fittings shall also be soil tight and gasketed.

- D. Where indicated on the Drawings, HDPE pipe shall be slotted or perforated by the manufacturer prior to delivery to the job site. Coupling bands shall conform to the manufacturer's specifications. Couplers shall cover not less than one corrugation on each section of pipe.

2.4 POLYVINYL CHLORIDE (PVC) PIPE:

Pipe and fittings shall comply with the requirements of ASTM D3034, rated SDR 35 and ASTM D2665 for Schedule 40 and Schedule 80 pipe and fittings. Pipe shall be continually marked with manufacturer's name, pipe size, cell classification, SDR rating, and ASTM D3034 classification.

2.5 STORM DRAIN MANHOLES

A. Precast Concrete

1. Manholes shall be 48-inch minimum inside diameter, precast concrete units, 4,000 psi minimum compressive strength, with eccentric cone section tapering to 24-inch diameter and monolithic base section meeting the requirements of ASTM C478. All structures shall be designed for HS-20 loading and shall be sufficient diameter to accept the pipe penetrations indicated on the Drawings.
2. Precast unit joint seals shall be performed butyl rubber O-ring type seals meeting the requirements of ASTM C990.
3. Openings for pipe and materials to be embedded in the walls of the manholes sections for joint seals shall be cast in the sections at the required locations during manufacture. Sections with incorrectly cast and patched pipe openings will be rejected.
4. Openings shall be cast into the manhole sections to receive entering pipes during manufacture. The openings shall be sized to provide a uniform 2-inch maximum annular space between the outside of the pipe wall and the opening in the riser for RCP. The openings shall be sized to accommodate flexible boot connections for all other pipe materials.
5. Manhole pipe openings shall be solidly filled with non-shrink mortar for RCP.
6. Manhole pipe connections for all other pipe materials shall be flexible boots as manufactured by Press-Seal, Trelleborg, A-Lok or approved equivalent.

B. Unit Masonry Construction:

1. Brick shall be sewer brick conforming to ASTM C32, Grade MS or building brick conforming to ASTM C62, Grade SW.
2. Concrete block shall be solid block and shall conform to the ASTM C139.
3. Mortar shall be in conformance with ASTM C270, Type M. The mortar shall be composed of Portland cement hydrated lime, and sand, in the proportions of 1 part cement to 1/4-part hydrated lime to 3-1/2 parts sand by volume.
4. Cement shall be Type I or II Portland cement conforming to ASTM C150. Where masonry is exposed to salt water, Type II shall be used.
5. Hydrated lime shall be Type S conforming to ASTM C207.
6. Sand for masonry mortar shall conform to the gradation requirements of ASTM C144.

- C. Steps: Steps for manholes shall be steel reinforced copolymer polypropylene plastic step with at least a 14-inch-wide stepping surface conforming to ASTM C478 and ASTM A615.

2.6 MANHOLE FRAME AND COVER:

Engineer: Check with local requirements Grey iron casting conforming to ASTM A48, heavy duty, with word "DRAIN" embossed on cover. Letter size shall be three inches (3 in.). Frame and cover shall have a minimum clear opening of 24 inches and have a minimum weight of 475 pounds. Frame and cover shall be East Jordan Iron Works 2114Z/2110A or approved equal.

2.7 CATCH BASINS AND DROP INLET

- A. Precast catch basins and drop inlets shall be manufactured in accordance with ASTM C478 4,000 psi minimum compressive strength to the diameters and depths shown on the Drawings. All structures shall be designed for HS-20 loading. Precast unit joints shall be sealed with butyl rubber in accordance with ASTM C990.
- B. Where required for hood, a slot and opening shall be cast in the catch basin wall for mounting the cast iron hood over the outlet pipe.
- C. When approved by the Engineer, catch basins and drop inlets may be constructed with brick or concrete block walls and poured reinforced concrete bases as an alternative to precast concrete units.
- D. Brick and concrete block and other materials shall conform to Article 2.03B.

2.8 CATCH BASIN FRAMES AND GRATES

- A. Catch basin frame and grates shall be cast iron, conforming to ASTM A48, Class 30. Where located in accessible ways, grate openings shall meet the requirements of federal, state, and local regulations adopted under the Americans with Disabilities Act (ADA).
- B. Single catch basin frame and grate shall be EJ 5546Z / 5520M5 or approved equivalent with four flanges, or with three flanges for use with gutter inlet or abutting vertical curb. Frame and grate for catch basin with shallow cover shall be EJ 5525Z / 5520M5 or approved equivalent.
- C. Double catch basin frame and grate shall be EJ 5448Z / 5520M5 or approved equivalent, with four flanges, or with three flanges for use with gutter inlet or abutting vertical curb.

2.9 CATCH BASIN HOODS

- A. Catch basin oil and debris traps (i.e., hoods, eliminators, etc.) shall be manufactured by the following, or approved equivalent:
 - 1. 'Eliminator' by Ground Water Rescue, Inc.
 - 2. 'Hood' by Neenah Foundry Company

2.10 AREA DRAINS

- A. Area drains shall be 'NYLOPLAST' drain basin with cast ductile iron grate manufactured by ADS.

2.11 INFILTRATION CHAMBERS

- A. Chambers shall be StormTech (model per plan) or approved equal.
- B. Chambers shall be made from virgin, impact-modified polypropylene copolymers
- C. Chamber rows shall provide continuous, unobstructed internal space with no internal support panels that would impede flow or limit access for inspection.
- D. The structural design of the chambers, the structural backfill and the installation requirements shall ensure that the load factors specified in the AASHTO LRFD Bridge Design Specifications, Section 12.12 are met for:
 - 1. Long-duration dead loads
 - 2. Short-duration live loads based on the AASHTO design truck with consideration for impact and multiple vehicle presences.
- E. Chambers shall conform to the requirements of ASTM F 2787 ‘Standard Practice for Structural Design of Thermoplastic Corrugated Wall Stormwater Collection Chambers.’
- F. Only chambers that are approved by the engineer will be allowed. The contractor shall submit (3 sets) of the following to the engineer for approval before delivering chambers to the project site.
 - 1. A structural evaluation by a registered structural engineer that demonstrates that the load factors specified in the AASHTO LRFD Bridge Design Specifications, Section 12.12 are met.
 - 2. Structural cross section detail on which the structural cross section is based.
- G. The installation of chambers shall be in accordance with the manufacturer’s latest installation instructions.

PART 3 - EXECUTION

3.1 GENERAL

- A. Contractor shall verify the location, size invert and type of existing pipes at all points of connection prior to ordering new utility materials.
- B. All pipe shall be laid accurately to the lines and grades shown on the Drawings and in conformance with the pipe manufacturer’s recommendations.
- C. As soon as the trench is excavated to the normal grade of the bottom of the trench, the Contractor shall immediately place the bedding material in the trench. The pipe shall be firmly bedded in the compacted bedding material accurately to the lines and grades shown on the Drawings.

- D. Laying Pipe: Each length of pipe shall be laid with firm, full and even bearing throughout its entire length, in a prepared trench. Pipe shall be laid with bells upgrade unless otherwise approved by the Engineer.
1. Each length of pipe shall be laid with firm, full and even bearing throughout its entire length, in a prepared trench. Pipe shall be laid with bells upgrade unless otherwise approved by the Engineer.
 2. Every length of pipe shall be inspected and cleaned of all dirt and debris before being laid. The interior of the pipe and the jointing seal shall be free from sand, dirt and trash. Extreme care shall be taken to keep the bells of the pipe free from dirt and rocks so that joints may be properly lubricated and assembled. No pipe shall be trimmed or chipped to fit.
 3. No length of pipe shall be laid until the proceeding lengths of pipe have been thoroughly embedded in place, to prevent movement or disturbance of the pipe alignment.
 4. Bedding shall be notched under pipe bells and joints where required to provide for uniform bearing under entire length of pipe.
- E. Optimum moisture content of bedding material shall be maintained to allow required compaction density.
- F. Where an existing pipe is to be extended, the same type of pipe shall be used, unless otherwise approved by the Engineer.
- G. Only full lengths of pipe shall be used in the installation except that partial lengths of pipe may be used at the entrance to structures, and to accommodate the required locations of service connection fittings.
- H. All pipes entering drainage structures shall be cut flush with the inside face of the structure, and the cut ends of the pipe surface within the structure shall be properly rounded and finished so that there will be no protrusion, ragged edges or imperfections that would impede the hydraulic characteristics of the stormwater flow. The method of cutting and finishing shall be subject to the approval of the Engineer.
- I. The Contractor shall protect the installation at all times during construction. Movement of construction equipment, vehicles, and loads over and adjacent to any pipe shall be performed at the Contractor's risk.
- J. At all times when pipe laying is not in progress, all open ends of pipes shall be closed by approved temporary watertight plugs. If water is in the trench when work is resumed, the plug shall not be removed until the trench has been dewatered and all danger of water entering the pipe eliminated.

3.2 RELATIONSHIP TO WATER MAINS

- A. When a drain pipe crosses above or below a water pipe, the following procedures shall be utilized:

[Horizontal Separation: Whenever possible drains shall be laid at a minimum of 5 feet horizontally from any existing or proposed water main. Should local conditions prevent a lateral separation of 5 feet, a drain may be laid closer than 5 feet to a water main if:

- a. It is laid in a separate trench, or if
 - b. It is laid in the same trench with the water mains located at one side on a bench of undistributed earth, and if
 - c. In either case the elevation of the top (crown) of the drain is at least 12 inches below the bottom (invert) of the water main.
1. Vertical Separation: Whenever drains must cross under water mains, the drain shall be laid at such an elevation that the top of the pipe is at least 12 inches below the bottom of the water main. When the elevation of the drain cannot be varied to meet the above requirements, the water main shall be relocated to provide this separation or reconstructed with mechanical-joint pipe for a distance of 10 feet on each side of the drain. One full length of water main should be centered over the drain so that both joints will be as far from the sewer as possible.
 2. When it is impossible to obtain the horizontal and vertical separation stipulated above, both the water main and drain shall be constructed of mechanical-joint cement lined ductile iron pipe or other equivalent based on water tightness and structural soundness. Both pipes shall be pressure tested by an approved method to assure water tightness.

3.3 EXCAVATION AND BACKFILLING FOR PIPES

- A. The type of materials to be used in bedding and backfilling and the method of placement shall conform to the requirements of Section 31 0 000 - EARTHWORK, the details shown on the Drawings and the following.
- B. Embedment materials are those used for bedding, haunching and initial backfill around pipes as illustrated on the Drawings.
1. All embedment materials should be free from lumps of frozen soil or ice when placed. Embedment materials should be placed and compacted at optimum moisture content
- C. Trench Bedding: Material must be provided to ensure proper line and grade is maintained. Unsuitable or unstable materials shall be undercut and replaced with a suitable bedding material, placed in 6-inch lifts. Other methods of stabilization, such as geotextiles may be appropriate, and their use must be approved by the Engineer or Owner's Representative.
1. Provide a stable and uniform bedding for the pipe and any protruding features of its joints and/or fittings. The middle of the bedding equal to 1/3 of the pipe outside diameter should be loosely placed, with the remainder compacted to a minimum of 95 percent Modified Proctor Density.

- D. Haunching: Proper haunching provides a major portion of the pipe's strength and stability. Exercise care to insure placement and compaction of the embedment material in the haunches. For larger diameter pipes (pipes greater than 30-inch diameter), embedment materials should be worked under the haunches by hand. Haunching materials shall be placed and compacted in 6-inch maximum lifts, compacted to 95 percent Modified Proctor Density.
- E. Initial Backfill: The initial backfill shall be from the springline to 24 inches above the pipe to provide protection for the pipe from construction operations during placement of the final backfill and protect the pipe from stones or cobbles in the final backfill. Compact initial backfill per Section 31 00 00 - EARTHWORK.
 - 1. Flooding or jetting as a procedure for compaction are not allowed.
- F. Final Backfill: The final backfill should be the same material as the proposed embankment or surface finishes. Generally, the excavated material may be used as final backfill. Placement should be as specified for the embankment. In lieu of a specification, the final backfill should be placed in 12-inch maximum lifts and compacted to a minimum 95 percent modified proctor density to prevent excessive settlement at the surface. Compaction should be performed at optimum moisture content.
- G. Vehicular and Construction Loads: During construction, avoid heavy equipment loads (greater than 40,000 lbs. per axle) over the pipe. Additional temporary cover should be placed over the pipe for heavy construction load crossings. Hydrohammers or hoe-pak compactors may not be used over the pipe until at least 48 inches of cover have been provided.

3.4 MANHOLES, CATCH BASINS, AND DROP INLETS - PRECAST

- A. Manholes Catch Basins and Drop Inlets: Shall be constructed at the locations and to the lines, grades, dimensions and design shown on Drawings or as required by the Engineer.
- B. Precast Concrete Units: Shall be installed in a manner that ensures watertight construction and all leaks in precast concrete structures shall be sealed. If required, precast concrete structures shall be repaired or replaced to obtain watertight construction.
- C. Stubs shall be short pieces of pipe cut from the bell ends of the pipe. Stubs shall be plugged with brick masonry unless otherwise directed by the Engineer.
- D. Manhole Inverts shall conform accurately to the size of the adjoining pipes.
 - 1. Manhole inverts shall be constructed of 3,500 psi concrete as shown the Drawings.
 - 2. Inverts shall be laid out in smooth diameter curves of the longest possible radius to provide uniform flow channels.
 - 3. Invert shelves shall be graded with a 1-inch drop per one foot length sloped from the manhole walls.
- E. Manhole steps shall be accurately positioned and embedded in the concrete when the section is cast. Precast reinforced concrete manhole sections shall be set vertical and with sections and steps in true alignment.

- F. All holes in sections used for their handling shall be thoroughly plugged with rubber plugs made specifically for this purpose, or with mortar. The mortar shall be one part cement to 1-1/2 parts sand, mixed slightly damp to the touch, hammered into the holes until it is dense and an excess of paste appears on the surface, and finished smooth and flush with the adjoining surfaces.
- G. Precast sections shall be level and plumb with approved joint seals. Water shall not be permitted to rise over newly made joints until after inspection and acceptance. All joints shall be watertight.
- H. Openings which have to be cut in the sections in the field shall be carefully made to prevent damage to the riser. Damaged risers will be rejected and shall be replaced at no additional cost to the Owner.

3.5 CHANGE IN TYPE STRUCTURES

- A. Where indicated on the Drawings, existing subsurface drain structures shall be converted to the new structure types in the following manner:
 - 1. Catch Basins to Manholes
 - a. Fill basin sump with 3,000 psi concrete and create new inverts at the elevations and sizes indicated and in accordance with specifications and details for new drain manholes.
 - b. Provide and adjust to grade new drain manhole frame and cover.
 - c. Stockpile existing frame and grade per Owner's directions.
 - 2. Manholes to Catch Basins or Drain Inlets
 - a. Where a sump is indicated on the Drawings, replace existing manhole structure with new precast concrete catch basin structure.
 - b. Where a sump is not indicated on the Drawings, replace existing frame and cover with new frame and grate and adjust to grade per these specifications and details for new catch basins.
 - c. Stockpile existing manhole frame and cover per Owner's directions.

3.6 BRICK MASONRY

- A. Brick masonry structures shall be watertight. All leaks in brick masonry structures shall be sealed. All brick masonry shall be laid by skilled workmen.
- B. All beds on which masonry is to be laid shall be cleaned and wetted properly. Brick shall be wetted as required to be damp, but free of any surface water when placed in the work. Bed joints shall be formed of a thick layer of mortar which shall be smoothed or furrowed slightly. Head joints shall be formed by applying a full coat of mortar on the entire brick end, or on the entire side, and then shoving the mortar covered end or side of the brick tightly against the bricks laid previously. The practice of buttering at the corners of the brick and then throwing the mortar or crappings in the empty joints will not be permitted. Dry or butt joints will not be permitted. Joints shall be uniform in thickness and approximately 1/4 inch thick.

- C. Brickwork shall be constructed accurately to the required structure dimensions and tapered at the top to the dimensions of the flanges of the cast-iron frames, as shown on the Drawings.
- D. Joints on the inside face of walls shall be tooled slightly concave with an approved jointer when the mortar is thumbprint hard. The mortar shall be compressed with complete contact along the edges to seal the surface of the joints.
- E. All castings to be embedded in the brickwork shall be accurately set and built-in as the work progresses.
- F. Water shall not be allowed to flow against brickwork or to rise on the masonry for 60 hours after it has been laid, and any brick masonry damaged in this manner shall be replaced as directed at no additional cost to the Owner. Adequate precautions shall be taken in freezing weather to protect the masonry from damage by frost.

3.7 CONCRETE MASONRY UNITS

- A. Concrete masonry units shall be soaked in water before laying. As circular concrete block walls are laid-up, the horizontal joints and keyways shall be flushed full with mortar. As rectangular blocks are laid-up, all horizontal and vertical joints shall be flushed full with mortar. Plastering of the outside of block structures will not be required. No structure shall be backfilled until all mortar has completely set.

3.8 MANHOLE STEPS

- A. Steps shall be cast into the precast walls during manufacture.
- B. Steps in brick masonry and concrete units shall be installed as the masonry courses are laid.

3.9 CASTINGS

- A. Cast-iron frames for grates and covers shall be well bedded in cement mortar and accurately set to the proposed grades.
- B. All voids between the bottom flange and the structure shall be completely filled to make a watertight fit. A ring of mortar, at least one-inch (1 in.) thick and pitched to shed water away from the frame shall be placed over and around the outside of the bottom flange. The mortar shall extend to the outer edge of the masonry all around its circumference and shall be finished smooth. No visible leakage will be permitted.
- C. Structures within the limits of bituminous concrete pavement shall be temporarily set at the elevation of the bottom of the binder course. After the binder course has been compacted, the structures shall be set at their final grade. Backfill necessary around such structures after the binder course has been completed shall be made with 3,500 psi concrete.

3.10 CONNECTIONS TO EXISTING FACILITIES

- A. General Requirements: The Contractor shall make all required connections of the proposed drainage system into existing drainage system, where and as shown on the Drawings.
- B. Compliance with requirements of Owner of Facility: Connections into existing drainage system facilities shall be performed in accordance with the requirements of the Owner of the facility. The Contractor shall comply with all such requirements, including securing of all required permits, and paying the costs thereof.

3.11 MANHOLE CONNECTIONS

- A. Manhole pipe connections for precast manhole bases shall be a tapered hole filled with non-shrink waterproof grout for RCP. Manhole connections shall be flexible boot cast into the manhole wall for HDPE, PVC, and DIP. The stainless-steel clamp shall be protected from corrosion with a bitumastic coating.

3.12 ROOF DRAIN OR SIMILAR CONNECTIONS

- A. General Requirements: The Contractor shall make all required connections of the building drainage system pipes into the site drainage system at locations and at distances from the buildings as shown on the Drawings. If stubs are constructed for later connection to the building pipes, the ends shall be sealed with watertight plugs and marked with 2 x 4 risers for later location.
- B. Coordination with Building Contractor: The Contractor shall coordinate the work with the work of the building contractor to determine the exact location and elevation of the point of entry into the building.
- C. Connections: Roof drain connections to the site drainage utilities system shall be made with fittings supplied by the pipe manufacturer.

3.13 CLEANING

- A. The Contractor shall clean the entire drainage system of all debris and obstructions. Cleaning shall include removal of all formwork from structures, concrete and mortar droppings, construction debris, and dirt. The system shall be thoroughly flushed clean, and the Contractor shall furnish all necessary hose, pumps, pipe and other equipment that may be required for this purpose. No debris shall be flushed into existing drains, storm recharge chambers, storm drains and/or streams.

3.14 TESTING

- A. Testing shall be done with a mandrel with a minimum length that is greater than the pipe diameter, and a minimum diameter of 90 percent of the pipe diameter. If the mandrel cannot be pulled through the pipe after seven (7) days of completed trench backfill, the pipeline shall be deemed unacceptable and the pipe lines shall be removed and replaced.

- B. The Contractor shall make all necessary repairs or replacements required to permanently provide an open and structurally sound drainage system capable of supporting the anticipated loading from all sources throughout the year.

3.15 FINAL INSPECTION

- A. Upon completion of the work, and before final acceptance by the Engineer, the entire drainage system shall be subjected to a final inspection in the presence of the Engineer. The work shall not be considered as complete until all requirements for line, grade, cleanliness, mandrel tests, and other requirements have been met.

END OF SECTION 33 40 00

SECTION 33 40 20

WARNING AND TRACER TAPE

PART 1 - GENERAL

1.1 WORK INCLUDED

- A. This Section covers the furnishing, handling, and installation of warning and tracer tape, as called for on the Drawings.

1.2 SUBMITTALS

- A. In accordance with requirements of General Specifications, submit the following:
 - 1. Manufacturer's literature on the materials, colors and printing specified herein, shall be submitted to the Engineer for review.
 - 2. Tape samples shall also be submitted to the Engineer for review.

PART 2 - PRODUCT

2.1 ACCEPTABLE MANUFACTURERS

- A. Tape shall be manufactured by: Terra-Tape and Terra-Tape D by Reef Industries, Houston, TX; Markline and Detectatape by Allen Systems, Houston, TX; an equivalent tape by Industrial Tape and Supply Company, Atlanta, GA; or approved equal.

2.2 TAPE

- A. Warning and tracer tape shall be at least 6 inches wide.
- B. Tracer tape for non-ferrous pipe or conduit shall be constructed of a metallic core bonded to plastic layers. The metallic tracer tape shall be a minimum 5-mil thick and shall be located at a depth as indicated on the drawings.
- C. Warning tape for ferrous pipe or conduit shall consist of multiple bonded plastic layers. The non-metallic tracer tape shall elongate at least 500% before breaking.
- D. The tape shall bear the wording (or approved equivalent): 'BURIED DRAIN LINE BELOW' (with 'DRAIN' replaced by 'WATER', 'SEWER', 'ELECTRICAL', 'GAS', 'TELEPHONE', or 'CHEMICAL' as appropriate), continuously repeated every 30 inches to identify the pipe.
- E. Tape colors shall be as follows as recommended by the American Public Works Association (APWA):

Electric	Red
Gas	Yellow

Communications	Orange
Water	Blue
Sewer and Drain	Green

PART 3 - EXECUTION

3.1 INSTALLATION

- A. Warning and tracer tape shall be installed above the pipe or conduit it is to identify at depths as indicated on the Drawings.
- B. Follow the manufacturer's recommendations for installation.

END OF SECTION 33 40 20