



**BOARD OF CONTRACT AND SUPPLY  
CITY OF PROVIDENCE, RHODE ISLAND**

# REQUEST FOR PROPOSALS

**Item Description: Various Water Pipe Appurtenances**

**Procurement/MinuteTraq #: 49045**

**Date to be opened: 5/19/2025**

**Issuing Department: Providence Water Supply Board**

## **QUESTIONS**

- Please direct questions related to the process, how to fill out forms, and how to submit an application(Pages 1-8) to the Purchasing Department.
  - Email: [purchasing@providenceri.gov](mailto:purchasing@providenceri.gov)
    - Please use the subject line “**Solicitation Question**”
- Please direct questions relative to the Minority and Women’s Business Enterprise Program and the corresponding forms (Pages 10-11) to the MBE/WBE Outreach Director for the City of Providence, Grace Diaz
  - Email: [gdiaz@providenceri.gov](mailto:gdiaz@providenceri.gov)
    - Please use subject line “**MBE WBE Forms**”
- Please direct questions relative to the specifications outlined (beginning on page 14) to the issuing department’s subject matter expert:
  - Name: Paul Sherry
  - Title: Division Manager – T&D
  - Email Address: [paulsh@provwater.com](mailto:paulsh@provwater.com)

## **Pre-submission Conference**

There is no pre-bid conference scheduled for this item.

## **Deadline for questions submissions:**

**May 12, 2025**

## INSTRUCTIONS FOR SUBMISSION

**Meeting Date: 5/19/2025**

Bids may be submitted up to **2:15 P.M.** on the above meeting date at the **Department of the City Clerk, Room 311, City Hall, 25 Dorrance Street, Providence.** At 2:15 P.M. all bids will be publicly opened and read at the Board of Contract Meeting in Conference Room 305, on the 3<sup>rd</sup> floor of City Hall.

- Bidders must submit **2 copies** of their bid in sealed envelopes or packages labeled with the captioned **Item Description** and the **City Department to which the solicitation and bid are related and must include the company name and address on the envelope as well.** (On page 1).
- If required by the Department, please keep the original bid bond and check in only one of the envelopes.
- Communications to the Board of Contract and Supply that are not competitive sealed bids (i.e. product information/samples) should have **"NOT A BID"** written on the envelope or wrapper.
- Only use form versions and templates included in this solicitation. If you have an old version of a form **do not recycle it for use in this bid.**
- The bid envelope and information relative to the bid must be addressed to:

**Board of Contract and Supply  
Department of the City Clerk – City Hall, Room 311  
25 Dorrance Street  
Providence, RI 02903**

**\*\*PLEASE NOTE:** This bid may include details regarding information that you will need to provide (such as proof of licenses) to the issuing department before the formalization of an award.

*This information is **NOT** requested to be provided in your initial bid by design.*

**All bids submitted to the City Clerk become public record. Failure to follow instructions could result in information considered private being posted to the city's Open Meetings Portal and made available as a public record. The City has made a conscious effort to avoid the posting of sensitive information on the City's Open Meetings Portal, by requesting that such sensitive information be submitted to the issuing department only at their request.**

## **BID PACKAGE CHECKLIST**

Digital forms are available in the City of Providence Purchasing Department Office or online at <http://www.providenceri.gov/purchasing/how-to-submit-a-bid/>

The bid package **MUST** include the following, in this order:

- Bid Form 1: Bidder's Blank as the cover page/ 1<sup>st</sup> page (*see page 6 of this document*)
- Bid Form 2: Certification of Bidder as 2<sup>nd</sup> page (*see page 7 of this document*)
- Bid Form 3: Certificate Regarding Public Records (*see page 8 of this document*)
- Bid Form 4: Affidavit of City Vendor (*see pages 9 and 10 of this document*)
- Forms from the Minority and Women Business Enterprise Program: Based on Bidder Category. *See forms and instructions enclosed (pages 10-11) or on:*  
<https://www.providenceri.gov/purchasing/minority-women-owned-business-mbewbe-procurement-program/>

**\*Please note: MBE/WBE forms must be completed for EVERY bid submitted and must be inclusive of ALL required signatures. Forms without all required signatures will be considered incomplete.**

- Bidder's Proposal/Packet: Formal response to the specifications outlined in this RFP, including pricing information and details related to the good(s) or service(s) being provided. Please be mindful of formatting responses as requested to ensure clarity.
- Financial Assurance, *if requested* (as indicated on page 5 of this document under "Bid Terms")

**All of the above listed documents are REQUIRED.** (With the exception of financial assurances, which are only required if specified on page 5.)

**\*\*\*Failure to meet specified deadlines, follow specific submission instructions, or enclose all required documents with all applicable signatures will result in disqualification, or in an inability to appropriately evaluate bids.**

## NOTICE TO VENDORS

1. The Board of Contract and Supply will make the award to the lowest qualified and responsible bidder.
2. In determining the lowest responsible bidder, cash discounts based on preferable payment terms will not be considered.
3. Where prices are the same, the Board of Contract and Supply reserves the right to award to one bidder, or to split the award.
4. No proposal will be accepted if the bid is made in collusion with any other bidder.
5. Bids may be submitted on an "equal in quality" basis. The City reserves the right to decide equality. Bidders must indicate brand or the make being offered and submit detailed specifications if other than brand requested.
6. A bidder who is an out-of-state corporation shall qualify or register to transact business in this State, in accordance with the Rhode Island Business Corporation Act, RIGL Sec. 7-1.2-1401, et seq.
7. The Board of Contract and Supply reserves the right to reject any and all bids.
8. Competing bids may be viewed in person at the Department of the City Clerk, City Hall, Providence, immediately upon the conclusion of the formal Board of Contract and Supply meeting during which the bids were unsealed/opened. Bids may also be accessed electronically on the internet via the City's [Open Meetings Portal](#).
9. As the City of Providence is exempt from the payment of Federal Excise Taxes and Rhode Island Sales Tax, prices quoted are not to include these taxes.
10. In case of error in the extension of prices quoted, the unit price will govern.
11. The contractor will **NOT** be permitted to: a) assign or underlet the contract, or b) assign either legally or equitably any monies or any claim thereto without the previous written consent of the City Purchasing Director.
12. Delivery dates must be shown in the bid. If no delivery date is specified, it will be assumed that an immediate delivery from stock will be made.
13. A certificate of insurance will normally be required of a successful vendor.
14. For many contracts involving construction, alteration and/or repair work, State law provisions concerning payment of prevailing wage rates apply ([RIGL Sec. 37-13-1 et seq.](#))
15. No goods should be delivered, or work started without a Purchase Order.
16. **Submit 2 copies of the bid to the City Clerk, unless the specification section of this document indicates otherwise.**
17. Bidder must certify that it does not unlawfully discriminate on the basis of race, color, national origin, gender, gender identity or expression, sexual orientation and/or religion in its business and hiring practices and that all of its employees are lawfully employed under all applicable federal, state and local laws, rules and regulations. (See Bid Form 2.)

## **BID TERMS**

1. Financial assurances may be required in order to be a successful bidder for Commodity or Construction and Service contracts. If either of the first two checkboxes below is checked, the specified assurance must accompany a bid, or the bid will not be considered by the Board of Contract and Supply. The third checkbox indicates the lowest responsible bidder will be contacted and required to post a bond to be awarded the contract.

- a)  A certified check for \$\_\_\_\_\_ must be deposited with the City Clerk as a guarantee that the Contract will be signed and delivered by the bidder.
- b)  A bid bond in the amount of \_\_\_\_\_ per centum (%) of the proposed total price, must be deposited with the City Clerk as a guarantee that the contract will be signed and delivered by the bidder; and the amount of such bid bond shall be retained for the use of the City as liquidated damages in case of default. Any person signing a bid bond as an attorney-in-fact shall include with the bid bond an original, or a photocopy or facsimile of an original, power of attorney.
- c)  A performance and payment bond with a satisfactory surety company will be posted by the bidder in a sum equal to one hundred per centum (100%) of the awarded contract.
- d)  No financial assurance is necessary for this item.

2. Awards will be made within **nighty (90) days of bid opening**. All bid prices will be considered firm, unless qualified otherwise. Requests for price increases will not be honored.

3. Failure to deliver within the time quoted or failure to meet specifications may result in default in accordance with the general specifications. It is agreed that deliveries and/or completion are subject to strikes, lockouts, accidents, and Acts of God.

### **The following entry applies only for COMMODITY BID TERMS:**

4. Payment for partial delivery will not be allowed except when provided for in blanket or term contracts.

### **The following entries apply only for CONSTRUCTION AND SERVICE BID TERMS:**

- 5. Only one shipping charge will be applied in the event of partial deliveries for blanket or term contracts.
- 6. Prior to commencing performance under the contract, the successful bidder shall attest to compliance with the provisions of the Rhode Island Worker's Compensation Act, [RIGL 28-29-1, et seq.](#) If exempt from compliance, the successful bidder shall submit a sworn Affidavit by a corporate officer to that effect, which shall accompany the signed contract.
- 7. Prior to commencing performance under the contract, the successful bidder shall, submit a certificate of insurance, in a form and in an amount satisfactory to the City.

**BID FORM 1: Bidders Blank**

1. Bids must meet the attached specifications. Any exceptions or modifications must be noted and fully explained.
2. Bidder's responses must be in ink or typewritten, and all blanks on the bid form should be completed.
3. The price or prices proposed should be stated both in **WRITING** and in **FIGURES**, and any proposal not so stated may be rejected. **Contracts exceeding twelve months must specify annual costs for each year.**
4. Bids **SHOULD BE TOTALED** so that the final cost is clearly stated (unless submitting a unit price bid), however **each item should be priced individually**. Do not group items. Awards may be made on the basis of *total* bid or by *individual items*.
5. All bids **MUST BE SIGNED IN INK.**

**Name of Bidder (Firm or Individual):** \_\_\_\_\_

Contact Name: \_\_\_\_\_

Business Address: \_\_\_\_\_

Business Phone #: \_\_\_\_\_

Contact Email Address: \_\_\_\_\_

Agrees to bid on (Write the "Item Description" here): \_\_\_\_\_

If the bidder's company is based in a state *other than Rhode Island*, list name and contact information for a local agent for service of process that *is located within Rhode Island*

\_\_\_\_\_

Delivery Date (if applicable): \_\_\_\_\_

Name of Surety Company (if applicable): \_\_\_\_\_

Total Amount in Writing\*: \_\_\_\_\_

Total Amount in Figures\*: \_\_\_\_\_

*\*If you are submitting a unit price bid, please insert "Unit Price Bid"*

*Use additional pages if necessary for additional bidding details.*

\_\_\_\_\_  
Signature of Representation

\_\_\_\_\_  
Title

**BID FORM 2: Certification of Bidder**  
(Non-Discrimination/Hiring)

Upon behalf of \_\_\_\_\_ (Firm or Individual Bidding),

I, \_\_\_\_\_ (Name of Person Making Certification),

being its \_\_\_\_\_ (Title or "Self"), hereby certify that:

1. Bidder does not unlawfully discriminate on the basis of race, color, national origin, gender, sexual orientation and/or religion in its business and hiring practices.
2. All of Bidder's employees have been hired in compliance with all applicable federal, state and local laws, rules and regulations.

I affirm by signing below that I am duly authorized on behalf of Bidder, on  
this \_\_\_\_\_ day of \_\_\_\_\_ 20\_\_\_\_\_.

\_\_\_\_\_  
Signature of Representation

\_\_\_\_\_  
Printed Name

**BID FORM 3: Certificate Regarding Public Records**

Upon behalf of \_\_\_\_\_ (Firm or Individual Bidding),

I, \_\_\_\_\_ (Name of Person Making Certification),

being its \_\_\_\_\_ (Title or "Self"), hereby certify an

understanding that:

1. All bids submitted in response to Requests for Proposals (RFP's) and Requests for Qualification (RFQ's), documents contained within, and the details outlined on those documents become public record upon receipt by the City Clerk's office and opening at the corresponding Board of Contract and Supply (BOCS) meeting.
2. The Purchasing Department and the issuing department for this RFP/RFQ have made a conscious effort to request that sensitive/personal information be submitted directly to the issuing department and only at request if verification of specific details is critical the evaluation of a vendor's bid.
3. The requested supplemental information may be crucial to evaluating bids. Failure to provide such details may result in disqualification, or an inability to appropriately evaluate bids.
4. If sensitive information that has not been requested is enclosed or if a bidder opts to enclose the defined supplemental information prior to the issuing department's request in the bidding packet submitted to the City Clerk, the City of Providence has no obligation to redact those details and bears no liability associated with the information becoming public record.
5. The City of Providence observes a public and transparent bidding process. Information required in the bidding packet may not be submitted directly to the issuing department at the discretion of the bidder in order to protect other information, such as pricing terms, from becoming public. Bidders who make such an attempt will be disqualified.

I affirm by signing below that I am duly authorized on behalf of Bidder, on

this \_\_\_\_\_ day of \_\_\_\_\_ 20\_\_\_\_\_.

\_\_\_\_\_  
Signature of Representation

\_\_\_\_\_  
Printed Name



**BID FORM 4: Affidavit of City Vendor**

Per our Code of Ordinances [Sec. 21.-28.1 \(e\)](#), this form applies to a) the business, b) any political action committee whose name includes the name of the business, c) all persons holding ten (10) percent or greater equity interest or five thousand dollars (\$5,000.00) or greater cash value interest in the business at any time during the reporting period, d) all executive officers of the business entity, e) any spouse or dependent child of any individual identified in a) though d) above.

Executive officers who are not residents of the state of Rhode Island are exempted from this requirement.

Per [R.I.G.L. § 36-14-2](#), "Business" means a sole proprietorship, partnership, firm, corporation, holding company, joint stock company, receivership, trust, or any other entity recognized in law through which business for profit or not for profit is conducted.

Name of the person making this affidavit: \_\_\_\_\_

Position in the "Business" \_\_\_\_\_

Name of Entity \_\_\_\_\_

Address: \_\_\_\_\_

Phone number: \_\_\_\_\_

The number of persons or entities in your entity that are required to report under [Sec. 21.-28.1 \(e\)](#): \_\_\_\_\_

**Read the following paragraph and answer one of the options:**

Within the 12 month period preceding the date of this bid submission with the City of Providence, or with respect to the contracts that are not in writing within the 12 month period preceding the date of notification that the contract has reached the \$100,000 threshold, have you made campaign contributions within a calendar year to (please list all persons or entities required under [Sec. 21.-28.1 \(e\)](#)).

a. Members of the Providence City Council?  Yes  No

• If Yes, please complete the following:

Recipient(s) of the Contribution:

Contribution Date(s):

Contribution Amount(s):

b. Candidates for election or reelection to the Providence City Council?  Yes  No

• If Yes, please complete the following:

Recipient(s) of the Contribution:

Contribution Date(s):

Contribution Amount(s):

c. The Mayor of Providence?  Yes  No

• If Yes, please complete the following:

Recipient(s) of the Contribution:

Contribution Date(s):

Contribution Amount(s):

d. Candidates for election or reelection to the office of Mayor of Providence?  Yes  No

• If Yes, please complete the following:

Recipient(s) of the Contribution:

Contribution Date(s):

Contribution Amount(s):

\_\_\_\_\_  
Signed under the pains and penalties of perjury.

\_\_\_\_\_  
Position

## MBE/WBE Participation Plan

Please complete separate forms for each MBE/WBE subcontractor/supplier to be utilized on the solicitation.

Bidder's Name:				
Bidder's Address:				
Point of Contact:				
Telephone:				
Email:				
Procurement #:				
Project Name:				
Which one of the following describes your business' status in terms of Minority and/or Woman Owned Business Enterprise certification with the State of Rhode Island? (Check all that apply).	<input type="checkbox"/> MBE	<input type="checkbox"/> WBE	<input type="checkbox"/> Neither MBE nor WBE	
<p>This form is intended to capture commitments between the prime contractor/vendor and MBE/WBE subcontractors and suppliers, including a description of the work to be performed and the percentage of the work as submitted to the prime contractor/vendor. Please note that all MBE/WBE subcontractors/suppliers must be certified by the Office of Diversity, Equity and Opportunity at the time of bid. The MBE/WBE Directory can be found <a href="#">here</a>. Please visit, the <a href="#">City's MBE/WBE page</a> for details of the program (e.g. instructions and requirements).</p> <ul style="list-style-type: none"> <li><b>Nonprofit organizations are not required to complete the rest of this form.</b></li> <li><b>Construction projects unable to identify subcontractors prior to bid submission (e.g. Design Build) are required to provide updates to the MBE/WBE Outreach Office</b></li> </ul>				
Name of Subcontractor/Supplier:				
Type of RI Certification:	<input type="checkbox"/> MBE	<input type="checkbox"/> WBE	<input type="checkbox"/> Neither	
Address:				
Point of Contact:				
Telephone:				
Email:				
Detailed Description of Work to Be Performed by Subcontractor or Materials to be Supplied by Supplier Per the Scope of Work provided in the RFP				
Total Contract Value (\$):		Subcontract Value (\$):		Participation Rate (%):
Anticipated Date of Performance:				
I certify under penalty of perjury that the forgoing statements are true and correct.				
<b>Prime Contractor/Vendor Signature</b>	<b>Title</b>	<b>Date</b>		
<b>Subcontractor/Supplier Signature</b>	<b>Title</b>	<b>Date</b>		

**\*If you did not meet the 20% MBE/WBE combined participation goal, submit a Waiver Request Form.**

**MBE/WBE Waiver Request Form**

Fill out this form only if you did not meet the 20% MBE/WBE participation goal.  
 State-certified MBE or WBE Prime Bidders are NOT REQUIRED to fill out this form.

Submit this form to the City of Providence MBE/WBE Outreach Director, Grace Diaz, at [gdiaz@providenceri.gov](mailto:gdiaz@providenceri.gov), for review prior to bid submission. This waiver applies only to the current bid which you are submitting to the City of Providence and does not apply to other bids your company may submit in the future. **In case a waiver is needed, City Department Directors should not recommend a bidder for an award if this form is not included, absent or is not signed by the city of Providence MBE/WBE director.**

Prime Bidder: \_\_\_\_\_ Contact Email and Phone \_\_\_\_\_  
 Company Name, Address: \_\_\_\_\_ Trade \_\_\_\_\_  
 Project /Item Description (as seen on RFP): \_\_\_\_\_

To receive a waiver, you must list the certified MBE and/or WBE companies you contacted, the name of the primary individual with whom you interacted, and the reason the MBE/WBE company could not participate on this project.

MBE/WBE Company Name	Individual's Name	Company Name	Why did you choose not to work with this company?

I acknowledge the City of Providence's goal of a combined MBE/WBE participation is 20% of the total bid value. I am requesting a waiver of \_\_\_\_\_ % MBE/WBE (20% minus the value of **Box F** on the Subcontractor Disclosure Form). If an opportunity is identified to subcontract any task associated with the fulfillment of this contract, a good faith effort will be made to select MBE/WBE certified businesses as partners.

\_\_\_\_\_  
 Signature of Prime Contractor /  
 or Duly Authorized Representative

\_\_\_\_\_  
 Printed Name

\_\_\_\_\_  
 Date Signed

\_\_\_\_\_  
 Signature of City of Providence  
 MBE/WBE Outreach Director /  
 or Duly Authorized Representative

\_\_\_\_\_  
 Printed Name of City of Providence  
 MBE/WBE Outreach Director

\_\_\_\_\_  
 Date Signed

## **FOR CONSTRUCTION PROJECTS**

### **APPRENTICE REQUIREMENTS (Construction Projects Valued at \$100,000 or More).**

Attention of prospective bidders is called to the fact that this project is to be bid upon and executed under the City of Providence Code of Ordinances Chapter 21 Art. II [Section 21-28.1](#) c(1) and (2) related to utilizing apprentices in the contract. This ordinance outlines requirements for utilizing not less than 15% of total hours worked by apprentices. The City may lower this percentage only if it determines in writing that compliance is not feasible or that it would be unduly cost prohibitive to the project. The attention of prospective bidders is also called to the fact that reporting the efforts undertaken and progress towards achieving the requirements in this ordinance is a condition for payment. Compliance reporting shall be submitted with any contract payment requisition, in a format to be specified by the City. This demonstration of compliance through such reports shall be a condition of the requisition for payment to be processed. Upon the contract being awarded to the successful bidder, a mandatory meeting will be scheduled to review the project requirements relative to apprenticeship requirements and the process and protocols by which these goals will be achieved. At this meeting, specific forms and procedures for the documentation and achievement of these requirements by the successful bidder will be provided, discussed and agreed upon for the execution of the contract.

### **“FIRST SOURCE” REQUIREMENTS.**

Attention of prospective bidders is called to the fact that this project is to be bid upon and executed under the City of Providence Code of Ordinances [Chapter 21 Art. III 1/2 First Source Agreements](#) Sec. 21-91 through 21-96. This ordinance outlines requirements for hiring Providence residents to work on this project. The City may waive this requirement only upon a determination in writing that qualified residents of Providence are not available for the project, pursuant to Sec. 21-94(e). The attention of prospective bidders is called to the fact that reporting the efforts undertaken and progress towards achieving the requirements in this ordinance is a condition for payment. Compliance reporting shall be submitted with any contract payment requisition, in a format to be specified by the City. This demonstration of compliance through such reports shall be a condition of the requisition for payment to be processed. Upon the contract being awarded to the successful bidder, a mandatory meeting will be scheduled to review the project requirements relative to the First Source Agreements and the process and protocols by which these goals will be achieved. At this meeting, specific forms and procedures for the documentation and achievement of these requirements by the successful bidder will be provided, discussed, and agreed upon for the execution of the contract.

# **BID PACKAGE SPECIFICATIONS**

## SUPPLEMENTAL INFORMATION

If the issuing department for this RFP determines that your firm's bid is best suited to accommodate their need, you will be asked to provide proof of the following prior to formalizing an award.

An inability to provide the outlined items at the request of the department may lead to the disqualification of your bid.

*This information is **NOT** requested to be provided in your initial bid that you will submit to the City Clerk's office by the "date to be opened" noted on page 1. This list only serves as a list of items that your firm should be ready to provide on request.*

**All bids submitted to the City Clerk become public record.** Failure to follow instructions could result in information considered private being posted to the city's Open Meetings Portal and made available as a public record.

**You must be able to provide:**

- Business Tax ID
- Proof of Insurance.
- Certificate of Good Standing with the Rhode Island Secretary of State.



**BOARD OF CONTRACT AND SUPPLY  
CITY OF PROVIDENCE, RHODE ISLAND**

**CITY OF PROVIDENCE STANDARD TERMS & CONDITIONS**

1. The terms "you" and "your" contained herein refer to the person or entity that is a party to the agreement with the City of Providence ("the City") and to such person's or entity's employees, officers, and agents.
2. The Request For Proposals ("RFP") and these Standard Terms and Conditions together constitute the entire agreement of the parties ("the Agreement") with regard to any and all matters. By your submission of a bid proposal or response to the City's RFP, you accept these Standard Terms & Conditions and agree that they supersede any conflicting provisions provided by bid or in any terms and conditions contained or linked within a bid and/or response. Changes in the terms and conditions of the Agreement, or the scope of work thereunder, may only be made by a writing signed by the parties.
3. You are an independent contractor and in no way does this Agreement render you an employee or agent of the City or entitle you to fringe benefits, workers' compensation, pension obligations, retirement or any other employment benefits. The City shall not deduct federal or state income taxes, social security or Medicare withholdings, or any other taxes required to be deducted by an employer, and this is your responsibility to yourself and your employees and agents.
4. You shall not assign your rights and obligations under this Agreement without the prior written consent of the City. Any assignment without prior written consent of the City shall be voidable at the election of the City. The City retains the right to refuse any and all assignments in the City's sole and absolute discretion.
5. Invoices submitted to the City shall be payable sixty (60) days from the time of receipt by the City. Invoices shall include support documentation necessary to evidence completion of the work being invoiced. The City may request any other reasonable documentation in support of an invoice. The time for payment shall not commence, and invoices shall not be processed for payment, until you provide reasonably sufficient support documentation. In no circumstances shall the City be obligated to pay or shall you be entitled to receive interest on any overdue invoice or payment. In no circumstances shall the City be obligated to pay any costs associated with your collection of an outstanding invoice.
6. For contracts involving construction, alteration, and/or repair work, the provisions of applicable state labor law concerning payment of prevailing wage rates (R.I. Gen. Laws §§ 37-13-1 et seq., as amended) and the City's First Source Ordinance (Providence Code of Ordinances §§ 21-91 et seq., as amended) apply.
7. With regard to any issues, claims, or controversies that may arise under this Agreement, the City shall not be required to submit to dispute resolution or mandatory/binding arbitration. Nothing prevents the parties from mutually agreeing to settle any disputes using mediation or non-binding arbitration.
8. To the fullest extent permitted by law, you shall indemnify, defend, and hold harmless the City, its employees, officers, agents, and assigns from and against any and all claims, damages, losses, allegations, demands, actions, causes of action, suits, obligations, fines, penalties, judgments, liabilities, costs and expenses, including but not limited to attorneys' fees, of any nature whatsoever arising out of, in connection with, or resulting from the performance of the work provided in the Agreement.
9. You shall maintain throughout the term of this Agreement the insurance coverage that is required by the RFP or, if none is required in the RFP, insurance coverage that is considered in your industry to be commercially reasonable, and you agree to name the City as an additional insured on your general liability policy and on any umbrella policy you carry.
10. The City shall not subject itself to any contractual limitations on liability. The City shall have the time permitted within the applicable statute of limitations, and no less, to bring or assert any and all causes of action, suits, claims or demands the City may have arising out of, in connection with, or resulting from the performance of the work provided in the Agreement, and in no event does the City agree to limit your liability to the price of the Agreement or any other monetary limit.
11. The City may terminate this Agreement upon five (5) days' written notice to you if you fail to observe any of the terms and conditions of this Agreement, or if the City believes your ability to perform the



**BOARD OF CONTRACT AND SUPPLY  
CITY OF PROVIDENCE, RHODE ISLAND**

terms and conditions of this Agreement has been materially impaired in any way, including but in no way limited to loss of insurance coverage, lapsing of a surety bond, if required, declaration of bankruptcy, or appointment of a receiver. In the event of termination by the City, you shall be entitled to just and equitable compensation for any satisfactory work completed and expenses incurred up to the date of termination.

12. Written notice hereunder shall be deemed to have been duly served if delivered in person to the individual or member of the firm or entity or to an officer of the entity for whom it was intended, or if delivered at or sent by registered or certified mail to the last business address known by the party providing notice.
13. In no event shall the Agreement automatically renew or be extended without a writing signed by the parties.
14. You agree that products produced or resulting from the performance of the Agreement are the sole property of the City and may not be used by you without the express written permission of the City.
15. For any Agreement involving the sharing or exchange of data involving potentially confidential and/or personal information, you shall comply with any and all state and/or federal laws or regulations applicable to confidential and/or personal information you receive from the City, including but not limited to the Rhode Island Identity Theft Protection Act, R.I. Gen. Laws § 11-49.3-1, during the term of the Agreement. You shall implement and maintain appropriate physical, technical, and administrative security measures for the protection of, and to prevent access to, use, or disclosure of, confidential and/or personal information. In the event of a breach of such information, you shall notify the City of such breach immediately, but in no event later than twenty-four (24) hours after discovery of such breach.
16. The Agreement is governed by the laws of the State of Rhode Island. You expressly submit yourself to and agree that any and all actions arising out of, in connection with, or resulting from the performance of the Agreement or relationship between the parties shall occur solely in the venue and jurisdiction of the State of Rhode Island or the federal court located in Rhode Island.
17. The failure of the City to require performance of any provision shall not affect the City's right to require performance at any time thereafter, nor shall a waiver of any breach or default of this Agreement constitute a waiver of any subsequent breach or default or a waiver of the provision itself.
18. If any term or provision of this Agreement, or the application thereof to any person or circumstance shall, in any extent, be invalid or unenforceable, the remainder of this Agreement shall not be affected thereby, and each term and provision shall be valid and enforceable to the fullest extent permitted by law.



## Important Information to all Bidders

For

### VARIOUS WATER PIPE APPURTENANCES

1. This is a Blanket Contract from July 1, 2025, through June 30, 2026. **ALL PRICES QUOTED FROM THE AWARDED VENDOR MUST REMAIN FIRM FROM THIS PERIOD.**
2. All quoted prices are to include all costs, including freight, for deliveries to Providence Water Supply Board.
3. Deliveries will only be accepted Monday through Friday (Excluding Holidays) between the hours of 7:30 am through 3:00 pm. It is the responsibility of the vendor to accept proper signatures for all deliveries. **In stock item deliveries may be required on a next day basis.**
4. Providence Water will issue a primary award to one vendor by category and/or item and all other vendors will be issued secondary awards. If the primary awarded vendor is unable to fulfill the order in a reasonable time frame, Providence Water reserves the right to purchase from the secondary vendors based on price and/or availability.
5. Pricing for any items not listed on the blank will be obtained by competitive bidding of vendors participating in this RFP. Those items will be awarded based on price and/or availability.
6. Deliveries will be made at the request of the proper Providence Water Supply Board officials. **PROVIDENCE WATER RESERVES THE RIGHT TO REQUIRE PARTIAL ORDERS AND SHIPMENTS AS DEEMED NECESSARY.**
7. A packing slip must accompany all material listing all part numbers and descriptions.
8. The general and specific characteristics of the attached specifications shall not be interpreted as excluding any manufacturer or product that would reasonably be considered as a comparable product. **ANY COMPARABLE PRODUCT MUST BE APPROVED BY PROVIDENCE WATER OFFICIALS.**
9. The award of this contract in no way obligates Providence Water to buy the estimated quantities or spend the corresponding estimated dollars.
10. Providence Water reserves the right to cancel this contract at any time with 30 days' written notice.
11. Providence Water reserves the right to purchase any quantity of any item listed.

**LIST OF APPROVED MATERIALS / MANUFACTURERS  
FOR USE IN THE  
PROVIDENCE WATER DISTRIBUTION SYSTEM**

(As of June 26, 2024)



**DUCTILE IRON PIPE**

(Must Be Zinc Coated – US Made Only)

American DI Pipe Co.  
Atlantic States Cast Iron Pipe Co.  
U.S. Pipe & Foundry Co.  
McWane Ductile

**DUCTILE IRON FITTINGS**

(Must Be Zinc Coated – US Made Only)

Star Pipe Products  
Tyler/Union Foundry Co.  
U.S. Pipe & Foundry Co.

**VALVES**

American Valve  
American AVK Co.  
Clow Valve Co.  
Kennedy Valve  
M&H Valve Co.  
Mueller Co.  
U.S. Pipe & Foundry Co.  
Red-White Valve Corp.  
Apollo Valves

**VALVE AND SERVICE BOXES**

Bingham & Taylor  
East Jordan Iron Works  
General Foundries  
Mueller Co.  
Tyler Union / Biby  
The Ford Meter Box Co.  
A.Y. McDonald Manufacturing Co.  
EJ USA

**PIPE COUPLINGS**

ROMAC Industries, Inc.  
Smith-Blair, Inc.  
HYMAX  
The Ford Meter Box Co.  
Dresser Inc.  
Baker Coupling, LLC

**SERVICE ADAPTER COUPLINGS, PLASTIC**

The Harrington Corp (HARCO)

**FIRE HYDRANTS**

**Kennedy Guardian Hydrant - K81D,**  
by Kennedy Valve (Must be "Hydra-Shield - Custodian" ready  
for installation in Providence only)

**5-1/4" American-Darling - B-62-B-5,**  
by American Flow Control (Must be "Hydra-Shield - Custodian"  
ready for installation in Providence only)

**Clow Medallion,**  
by Clow Valve Co. (Must be "Hydra-Shield - Custodian" ready for  
installation in Providence only)

**JOINT RESTRAINT FOR DUCTILE IRON PIPE -  
MECHANICAL**

EBAA Iron Sales, Inc. MEGALUG MJ Retainer Gland  
Series 1100 – MJ Gland  
Series 1100SDB – Mid Span Restraint  
Star National Products  
"Star Tie-Anchor III Joint Restraint"  
Tyler Union  
Series 1000 TUFGRIP MJ Retainer Gland  
The Ford Meter Box Co.  
Uni-Flange Series 1400

**JOINT RESTRAINT FOR DUCTILE IRON PIPE-  
GASKETED**

American – Fast-Grip Gasket  
McWane Sure Stop 350 Gasket  
U.S. Pipe & Foundry Co. - "Field Lok 350" Gasket

**SERVICE BRASS / COPPER**

(Must meet "Lead Free Standard")

A.Y. McDonald Manufacturing Co.  
Cambridge Lee Industries, LLC  
Mueller Co.  
Red Hed Manufacturing  
The Ford Meter Box Co

*A Providence Water guidance document. This list is subject to change without notice. Customers or contractors are responsible for contacting Providence Water to verify their selection of materials prior to starting any construction.*

GIL INDUSTRIES 2" SLIMLINE FLUSHING HYDRANT

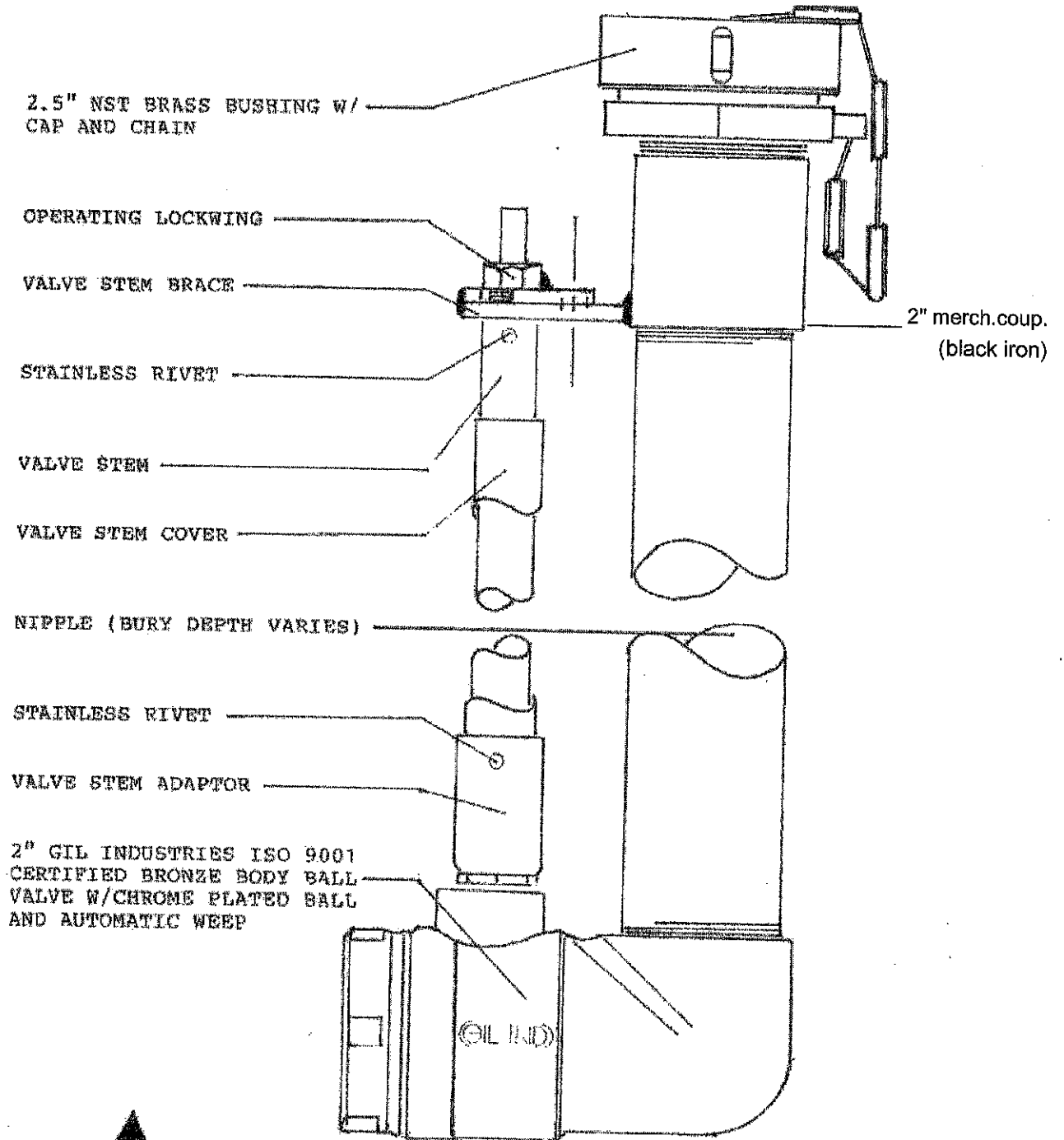

# #88-SS SAMPLING STATION SPEC SHEET

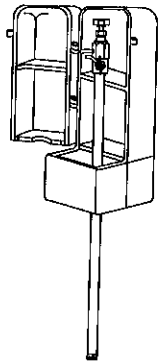

1 **3D VIEW**  
Scale: Not To Scale

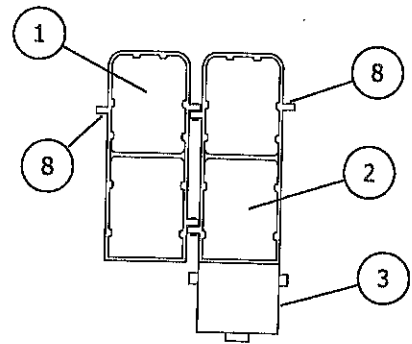
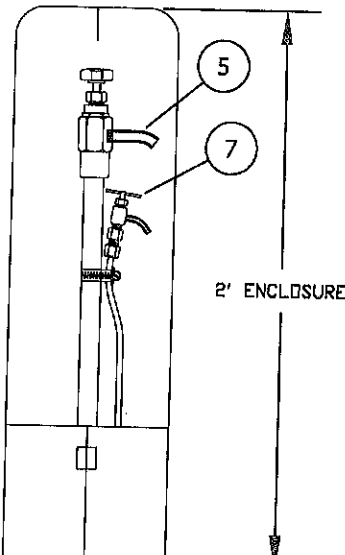

2 **ENCLOSURE OPEN VIEW**  
Scale: 3/4"=1'-0"

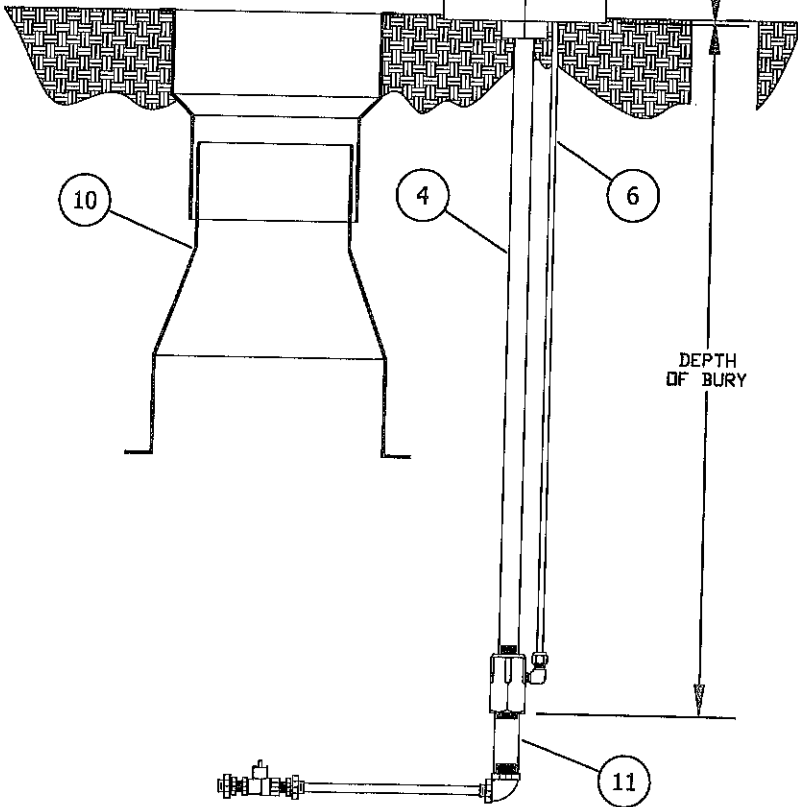

SAMPLING STATION SHALL BE \_\_\_\_\_' BURY, WITH A 3/4" FIP INLET, AND 7/16" UNTHREADED BLOW OFF AND SAMPLING BIBB.

STATION SHALL BE ENCLOSED IN A LOCKABLE, NON-REMOVABLE ALUMINUM BOX WITH HINGED OPENINGS.

WHEN OPEN, THE STATION SHALL REQUIRE NO KEY FOR OPERATION, AND ALL WATER FLOW SHALL PASS THRU AN ALL STAINLESS STEEL WATERWAY.

ALL WORKING PARTS SHALL BE OF STAINLESS STEEL AND SERVICABLE FROM ABOVE GROUND WITH NO DIGGING OR REPLACEMENT NEEDED.

A STAINLESS STEEL PET COCK WILL BE LOCATED BELOW THE SAMPLING BIBB TO ALLOW PUMPING OF ANY WATER REMAINING INSIDE THE STATION TO INSURE NON-FREEZING.

THE STATION SHALL BE MODEL #88-SS AS MANUFACTURED BY THE KUPFERLE FOUNDRY, ST. LOUIS MO. 63102 OR APPROVED EQUAL.

#88-SS SAMPLING STATION TO BE INSTALLED AT THE FOLLOWING LOCATIONS:

\_\_\_\_\_

\_\_\_\_\_

\_\_\_\_\_

\_\_\_\_\_

ITEM	ITEM / DESCRIPTION	NOTES
1	88 FRONT DOOR < COVER A >	
2	88 REAR DOOR < COVER B >	
3	88 BASE	2 PIECES
4	1/2" S.S. WATERWAY	
5	BLOW OFF & SAMPLING BIBB	
6	1/4" S.S. TUBING	
7	PET COCK	
8	LOCKING HOLE	
9	NOT USED	
10	VALVE BOX	BY OTHERS
11	3/4" S.S. NIPPLE	BY OTHERS

DRAWN  
DCL  
APPROVED  
DCL

DATE  
9/3/13  
SCALE  
1-1/2"=1'

Since 1857

**KUPFERLE FOUNDRY COMPANY**  
2611 NORTH 9TH STREET, ST. LOUIS, MO 63102  
314-231-8738 800-231-3990 FAX 314-231-2820  
<http://www.hydrants.com>

DD/MM/YY	ISSUED FOR REFERENCE
DATE	STATUS / REVISION

THIS DRAWING IS THE PROPERTY OF THE KUPFERLE FOUNDRY COMPANY. IT IS NOT TO BE USED OR DUPLICATED WITHOUT PERMISSION OF THE OWNER.

#88-SS SAMPLING STATION SHEET 1 OF 1



**Providence Water Various Types of Water Pipe Appurtenances Bidders Blank  
Fiscal Year 2026**

Part A		Curb Stops		Bid Price
Item	1	1" Curb Stop		\$
Item	2	1.5" Curb Stop		\$
Item	3	2" Curb Stop		\$
Part B		Corporation Stops		Bid Price
Item	1	1" Corporation Tap		\$
Item	2	1.5" Corporation Tap		\$
Item	3	2" Corporation Tap		\$
Part C		Service Saddles		Bid Price
Item	1	6" x 1"	CC thread-w/304ss hardware	\$
Item	2	6" x 1.5"	CC thread-w/304ss hardware	\$
Item	3	6" x 2"	CC thread-w/304ss hardware	\$
Item	4	8" x 1"	CC thread-w/304ss hardware	\$
Item	5	8" x 1.5"	CC thread-w/304ss hardware	\$
Item	6	8" x 2"	CC thread-w/304ss hardware	\$
Item	7	12" x 1"	CC thread-w/304ss hardware	\$
Item	8	12" x 1.5"	CC thread-w/304ss hardware	\$
Item	9	12" x 2"	CC thread-w/304ss hardware	\$
Item	10	16" x 1"	CC thread-w/304ss hardware	\$
Item	11	16" x 1.5"	CC thread-w/304ss hardware	\$
Item	12	16" x 2"	CC thread-w/304ss hardware	\$
Part D		Mechanical Joint Restraint		Bid Price
Item	1	4"	MJ Restraint Only	\$
Item	2	6"	MJ Restraint Only	\$
Item	3	6" Oversized	Gray and/or XL	\$
Item	4	8"	MJ Restraint Only	\$
Item	5	12"	MJ Restraint Only	\$
Part E		MJ Accessory Packs		Bid Price
Item	1	4"	MJ Assy Pack USA	\$
Item	2	6"	MJ Assy Pack USA	\$
Item	3	8"	MJ Assy Pack USA	\$
Item	4	12"	MJ Assy Pack USA	\$
Part F		Adjustable Cast Iron Valve Boxes, Risers, Buffalo Boxes, Service Boxes, Service Box Extensions, Gate Box Covers and Service Box Covers-All USA Made		Bid Price
Item	1	N.E. Style 2 Pcs. Cast Iron Valve Box - Cover only USA		\$
Item	2	N.E. Style 2 Pcs. Cast Iron Valve Box -Top Only USA		\$
Item	3	N.E. Style 2 Pcs. Cast Iron Valve Box -Bottom Only USA		\$
Item	4	4.5'-5.5' Service Box w/Plug Cover (Erie Style) USA		\$
Item	5	1/2" X 24" Stainless Steel Service Box Rod USA		\$
Item	6	Service Box Covers (Plug) Only USA		\$
Item	7	1" Valve Box Riser USA		\$
Item	8	1.5" Valve Box Riser USA		\$
Item	9	2" Valve Box Riser USA		\$
Item	10	3" Valve Box Riser USA		\$
Item	11	4" Valve Box Riser USA		\$
Item	12	6" Valve Box Riser USA		\$
Item	13	6" Service Box Extension USA		\$
Item	14	9" Service Box Extension USA		\$
Item	15	12" Service Box Extension USA		\$
Item	16	18" Service Box Extension USA		\$
Item	17	4.5" x 12" Pioneer Top Extension S11		\$
Item	18	S11 Cover		\$

Item	19	5.25" x 12" Pioneer Top Extension S21		\$
Item	20	S21 Cover		\$
<b>Part G</b>	<b>Item</b>	<b>Resilient Wedge Gate Valves</b>		<b>Bid Price</b>
Item	1	4" Resilient Wedge Gate Valve		\$
Item	2	6" Resilient Wedge Gate Valve		\$
Item	3	8" Resilient Wedge Gate Valve		\$
Item	4	12" Resilient Wedge Gate Valve		\$
<b>Part H</b>	<b>Item</b>	<b>Resilient Wedge Tapping Valves</b>		<b>Bid Price</b>
Item	1	4" Resilient Wedge Tapping Valve		\$
Item	2	6" Resilient Wedge Tapping Valve		\$
Item	3	8" Resilient Wedge Tapping Valve		\$
Item	4	12" Resilient Wedge Tapping Valve		\$
<b>Part I</b>	<b>Item</b>	<b>Pipe Couplings - 2 Bolt Wide Range</b>	<b>OD Ranges</b>	<b>Bid Price</b>
Item	1	1.5"	1.61 - 2.13	\$
Item	2	2"	2.10-3.03	\$
Item	3	4"	4.25-5.63	\$
Item	4	6"	6.42-7.68	\$
Item	5	8"	8.54-9.84	\$
Item	6	12"	12.40-13.66	\$
Item	7	12"	13.15-14.41	\$
<b>Part J</b>	<b>Item</b>	<b>Single Band Repair Clamps - Stainless Steel Band w/304ss hardw</b>	<b>OD Ranges</b>	<b>Bid Price</b>
Item	1	3/4" x 6"	Full Wrap	\$
Item	2	1" x 6"	Full Wrap	\$
Item	3	1.5" x 6"	Full Wrap	\$
Item	4	2" x 6"	Full Wrap	\$
Item	5	4" x 7.5"	4.74" - 5.14"	\$
Item	6	6" x 7.5"	6.84" - 7.24" CI	\$
Item	7	6" x 7.5"	7.05" - 7.45" AC	\$
Item	8	6" x 12"	6.84" - 7.24" CI	\$
Item	9	6" x 12"	7.05" - 7.45" AC	\$
Item	10	6" x 12"x3/4"	7.05" - 7.45" AC	\$
Item	11	6" x 12"x1"	7.05" - 7.45" AC	\$
Item	12	6" x 15"	6.84" - 7.24" CI	\$
Item	13	6" x 15"	7.05" - 7.45" AC	\$
Item	14	8" x 7.5"	8.99" - 9.39" CI	\$
Item	15	8" x 7.5"	9.27" - 9.67" AC	\$
Item	16	8" x 12"	8.99" - 9.39" CI	\$
Item	17	8" x 12"	9.27" - 9.67" AC	\$
Item	18	8" x 12" x 3/4"	9.27" - 9.67" AC	\$
Item	19	8" x 12" x 1"	9.27" - 9.67" AC	\$
Item	20	8" x 15"	8.99" - 9.39" CI	\$
Item	21	8" x 15"	9.27" - 9.67" AC	\$
Item	22	12" x 12"	13.00" - 13.50" CI	\$
Item	23	12" x 12"	13.44" - 14.04" AC	\$
Item	24	12" x 12"	13.92" - 14.38" AC	\$
Item	25	12" x 12" x 3/4"	13.44" - 14.04" AC	\$
Item	26	12" x 12" x 1"	13.44" - 14.04" AC	\$
Item	27	12" x 15"	13.44" - 14.04" AC	\$
Item	28	12" x 15"	13.92" - 14.38" AC	\$
<b>Part K</b>	<b>Item</b>	<b>Stainless Steel Tapping Sleeves w/ Stainless Flange</b>	<b>OD Ranges</b>	<b>Bid Price</b>
Item	1	6" x 4"	6.90" - 7.30" CI	\$
Item	2	6" x 4"	7.10" - 7.50" AC	\$
Item	3	6" x 6"	6.90" - 7.30" CI	\$
Item	4	6" x 6"	7.10" - 7.50" AC	\$
Item	5	8" x 4"	9.05" - 9.45" CI	\$

Item	6	8" x 4"	9.30" - 9.70" AC	\$
Item	7	8" x 6"	9.05" x 9.45" CI	\$
Item	8	8" x 6"	9.30" - 9.70" AC	\$
Item	9	8" x 8"	9.05" x 9.45" CI	\$
Item	10	8" x 8"	9.30" - 9.70" AC	\$
Item	11	12" x 4"	13.10" - 13.50" CI	\$
Item	12	12" x 4"	14.00" - 14.40" AC	\$
Item	13	12" x 6"	13.10" - 13.50" CI	\$
Item	14	12" x 6"	14.00" - 14.40" AC	\$
Item	15	12" x 8"	13.10" - 13.50" CI	\$
Item	16	12" x 8"	14.00" - 14.40" AC	\$
Item	17	16" x 4"	17.33" - 17.87" CI	\$
Item	18	16" x 4"	17.88" - 18.43" AC	\$
Item	19	16" x 6"	17.33" - 17.87" CI	\$
Item	20	16" x 6"	17.88" - 18.43" AC	\$
Item	21	16" x 8"	17.33" - 17.87" CI	\$
Item	22	16" x 8"	17.88" - 18.43" AC	\$
<b>Part L</b>	<b>Item</b>	<b>Mortar Lined Push-On Ductile Iron Pipe</b>		<b>Bid Price</b>
Item	1	4" Class 52		\$
Item	2	4" Class 52-Zinc Coated		\$
Item	3	6" Class 52		\$
Item	4	6" Class 52 Zinc Coated		\$
Item	5	8" Class 52		\$
Item	6	8" Class 52 Zinc Coated		\$
Item	7	12" Class 52		\$
Item	8	12" Class 52 Zinc Coated		\$
Item	9	12" Class 56 Zinc Coated		\$
<b>Part M</b>	<b>Item</b>	<b>Brass Couplings, Unions and Various Fittings</b>		<b>Bid Price</b>
Item	1	3/4" x 3/4" Copper to Copper	Brass Coupling-Compression	\$
Item	2	3/4" x 1" Copper to Copper	Brass Coupling-Compression	\$
Item	3	1" x 1" Copper to Copper	Brass Coupling-Compression	\$
Item	4	1" x 1.5" Copper to Copper	Brass Coupling-Compression	\$
Item	5	1.5" x 1.5" Copper to Copper	Brass Coupling-Compression	\$
Item	6	1.5" x 2" Copper to Copper	Brass Coupling-Compression	\$
Item	7	2" x 2" Copper to Copper	Brass Coupling-Compression	\$
Item	8	3/4" X 1" Universal Transitional Coupling	Size B to Size C	\$
Item	9	1" X 1" Universal Transitional Coupling	Size C to Size C	\$
Item	10	1" X 1.25" Universal Transitional Coupling	Size C to Size D	\$
Item	11	1.25" X 1.50" Universal Transitional Coupling	Size D to Size E	\$
Item	12	1.5" X 1" Universal Transitional Coupling	Size E to Size C	\$
Item	13	1.5" x 1.5" Universal Transitional Coupling	Size E to Size E	\$
Item	14	2" Male IP Thread X 2" CTS Compression	Adaptor	\$
Item	15	5/8" x 1" Tap Adaptor	#RH445121	\$
<b>Part N</b>	<b>Item</b>	<b>Mechanical Bends (Zinc Coated and Non Zinc)</b>		<b>Zinc</b>
Item	1	4" x 1/4" Bend	MJ x MJ	\$
Item	2	6" x 1/4" Bend	MJ x MJ	\$
Item	3	8" x 1/4" Bend	MJ x MJ	\$
Item	4	12" x 1/4" Bend	MJ x MJ	\$
Item	5	4" x 1/8" Bend	MJ x MJ	\$
Item	6	6" x 1/8" Bend	MJ x MJ	\$
Item	7	8" x 1/8" Bend	MJ x MJ	\$
Item	8	12" x 1/8" Bend	MJ x MJ	\$
Item	9	4" x 1/16" Bend	MJ x MJ	\$
Item	10	6" x 1/16" Bend	MJ x MJ	\$
Item	11	8" x 1/16" Bend	MJ x MJ	\$

Item	12	12" x 1/16" Bend	MJ x MJ	\$
Item	13	4" x 1/32" Bend	MJ x MJ	\$
Item	14	6" x 1/32" Bend	MJ x MJ	\$
Item	15	8" x 1/32" Bend	MJ x MJ	\$
Item	16	12" x 1/32" Bend	MJ x MJ	\$
<b>Part O</b>	<b>Item</b>	<b>Anchor and Mechanical Tee's (Zinc Coated and Non Zinc)</b>		<b>Zinc</b>
Item	1	6" x 4"	MJ Tee	\$
Item	2	6" x 6"	MJ Tee	\$
Item	3	8" x 4"	MJ Tee	\$
Item	4	8" x 6"	MJ Tee	\$
Item	5	8" x 8"	MJ Tee	\$
Item	6	12" x 4"	MJ Tee	\$
Item	7	12" x 6"	MJ Tee	\$
Item	8	12" x 8"	MJ Tee	\$
Item	9	6" x 6"	Anchor Tee	\$
Item	10	8" x 6"	Anchor Tee	\$
Item	11	8" x 8"	Anchor Tee	\$
Item	12	12" x 6"	Anchor Tee	\$
Item	13	12" x 8"	Anchor Tee	\$
<b>Part P</b>	<b>Item</b>	<b>Valve Box Aligners</b>		<b>Bid Price</b>
Item	1	BoxLox Valve Box Alignment Device Model 2		\$
Item	2	BoxLok Valve Box Alignment Device Model K1		\$
Item	3	Adaptor Inc. Valve box Adaptor II		\$
Item	4	Adaptor Inc. Multi-Fit Adaptor		\$
<b>Part Q</b>	<b>Item</b>	<b>Field Loc Gaskets</b>		<b>Bid Price</b>
Item	1	4"	US Pipe Field Lok Gaskets	\$
Item	2	6"	US Pipe Field Lok Gaskets	\$
Item	3	8"	US Pipe Field Lok Gaskets	\$
Item	4	12"	US Pipe Field Lok Gaskets	\$
<b>Part R</b>	<b>Item</b>	<b>Foster Adaptors</b>		<b>Bid Price</b>
Item	1	4"	MJ Adaptor	\$
Item	2	6"	MJ Adaptor	\$
Item	3	8"	MJ Adaptor	\$
Item	4	12"	MJ Adaptor	\$
<b>Part S</b>	<b>Item</b>	<b>Universal Ferncos - Max Adaptors, Hulk4</b>		<b>Bid Price</b>
Item	1	4"	Wide Range	\$
Item	2	6"	Wide Range	\$
Item	3	8"	Wide Range	\$
Item	4	10"	Wide Range	\$
Item	5	12"	Wide Range	\$
<b>Part T</b>	<b>Item</b>	<b>Miscellaneous Items</b>		<b>Bid Price</b>
Item	1	5/8"	1/2" MTR X 1/2" MIP Coupling	\$
Item	2	3/4"	3/4" MTR X 3/4" MIP Coupling	\$
Item	3	1"	1" MTR X 1" MIP Coupling	\$
Item	4	1-1/2"	Meter Coupling, IP, 3-Pcs, RH	\$
Item	5	2"	Meter Coupling, IP, 3-Pcs, RH	\$
Item	6	#88-SS Sampling Station - 4' 6" Bury	Eclipse Sample Station	\$
Item	7	Gil 2" Slimline Flushing Hydrant - 3 Foot	Blow off Assembly	\$
Item	8	Gil 2" Slimline Flushing Hydrant - 4 Foot	Blow off Assembly	\$

**Please refer to the list of approved materials and manufacturers**